

ITEM# _____

PROJECT _____

DATE _____

Tiger Super Automatic Espresso Machine with Steam Wand



Model Tiger XL S Series

Dimensions: 25.5"H x 15.8"W x 18.1"D
(64.8 cm H x 40.1 cm W x 46 cm D)

Features

BUNN Espresso® Tiger XL S Series

- Up to 180 shots per hour from less than 16" of counter space.
- Intelligent modular brewing chamber adjusts espresso for consistent flavor profile.
- Simulates Barista tamping and polishing motion to provide uniform extraction.
- Two hoppers for regular, decaf or other specialty beans.
- Each hopper holds 1.75 lbs of fresh beans.
- Adjusts for 4.5 to 7.4 inch cup clearance.
- Pod brewing feature standard on all models.
- Easy to use control pad and display screen guides user through steps for making drinks.
- Simple daily cleaning process with automatic reminder and lockout.
- Intellisteam™ wand shuts steam off when the milk reaches the preset temperature. No need to monitor temperature with a thermometer.

For current specification sheets and other information, go to www.bunn.com.

Related Products

Espresso Water Quality System

EQHP-ESP
Product No. :39000.0008



Replacement Cartridge

EQHP-ESPCRTG
Product No.: 39000.1008

Urnex® Cafiza™ Cleaning Tablets

Product No.: 36000.1189 (100 count)
Product No.: 36000.1188 (12/case)



Urnex® Rinza™

Milk Frother Cleaner
Product No.: 39265.0000 (each)
Product No.: 39265.0001 (6/case)



Cup Heater

Product No.: 35800.6400



Model

Tiger XL S-2

Agency Listing



Dimensions & Specifications

CANADA



Model	Product #	Volts	Amps	Tank Heater Watts	Total Watts	Capacity	Cubic ft ³ /m ³	Weight lbs/kg	Cord Attached
Tiger XL S-2	35800.6907	208	11.5	2000	2400	180 shots/hr	12.5 / .35	103 / 46.7	Yes/ No Plug

Capacity per Hour: Espresso: 180
 Cappuccino: 120
 Latte: 100
 POD Products: 60
 Hot Water: 7.9 gallons (30 litres)
 Steam: 1-2 bar continuous operation

Model includes: Machine, water filtration system and installation.

Electrical: Model requires 2-wire grounded service rated 208V, single phase, 50/60 Hz.

Plumbing: 20-100 psi (138 - 690 kPa). Machine supplied with 1/4" male flare fitting. All machines are supplied with a waste water hose and must be connected to a drain.

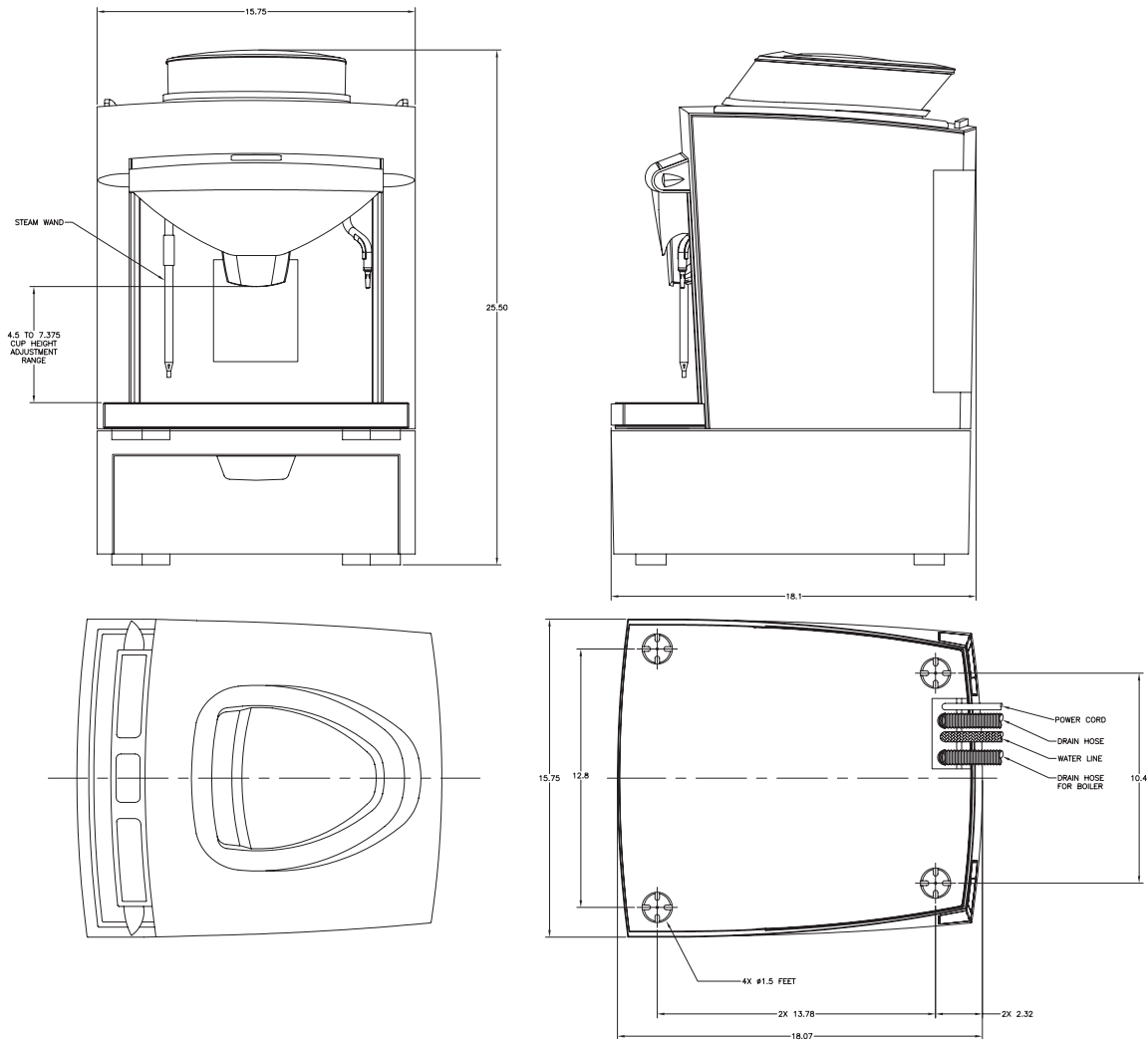

Bunn-O-Matic Corporation of Canada - 280 Industrial Pkwy. S. Aurora, Ontario L4G 3T9 • 905-841-2866 • Fax 905-841-2775 • www.bunn.com

BUNN® practices continuous product research and improvement. We reserve the right to change specifications and product design without notice. Such revisions do not entitle the buyer to corresponding changes, improvements, additions or replacements for previously purchased equipment.

All dimensions shown in inches. Bunn Corporation owns all copyrights relating to materials in this publication. Please contact Bunn Corporation to request permission to reproduce any portion of this publication.