

MICRO BEAMER

RGBW

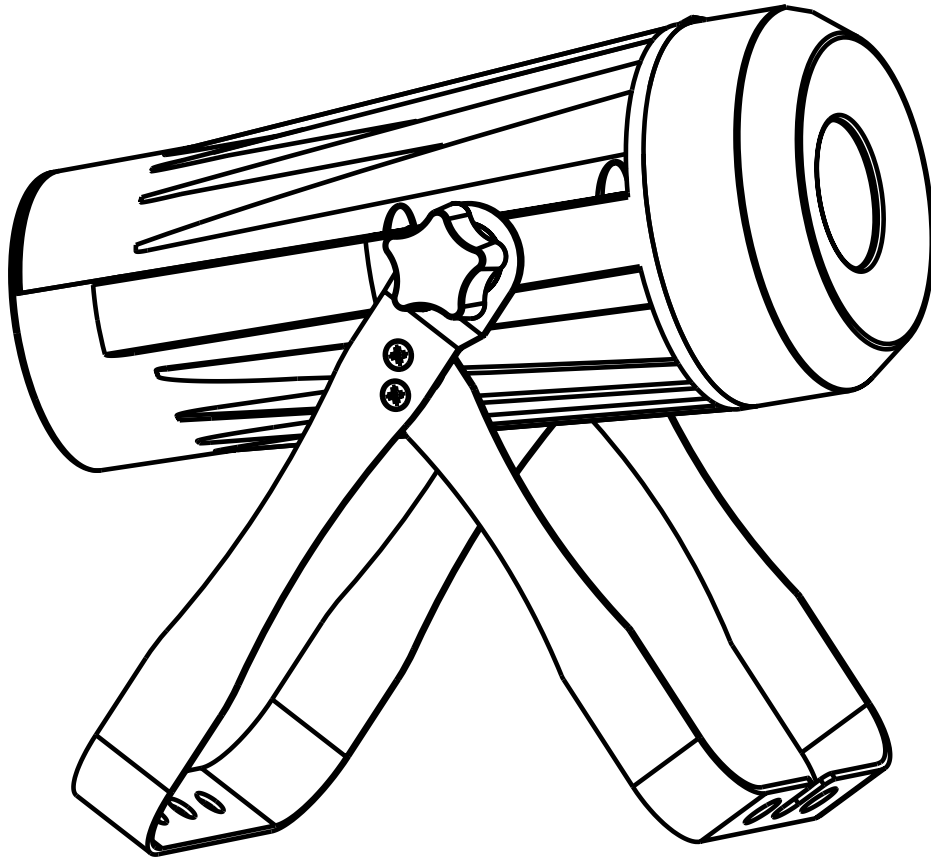

**4in 1 RGBW LED PROJECTOR
NO COLOR SHADOWS**

Operation Manual

CE

Version: 1.0

BriteQ[®]
LIGHT RESEARCH



EN - DISPOSAL OF THE DEVICE

Dispose of the unit and used batteries in an environment friendly manner according to your country regulations.

FR - DÉCLASSER L'APPAREIL

Débarrassez-vous de l'appareil et des piles usagées de manière écologique Conformément aux dispositions légales de votre pays.

NL - VERWIJDEREN VAN HET APPARAAT

Verwijder het toestel en de gebruikte batterijen op een milieuvriendelijke manier conform de in uw land geldende voorschriften.

DU - ENTSORGUNG DES GERÄTS

Entsorgen Sie das Gerät und die Batterien auf umweltfreundliche Art und Weise gemäß den Vorschriften Ihres Landes.

ES - DESHACERSE DEL APARATO

Reciclar el aparato y pilas usadas de forma ecologica conforme a las disposiciones legales de su país.

PT - COMO DESFAZER-SE DA UNIDADE

Tente reciclar a unidade e as pilhas usadas respeitando o ambiente e em conformidade com as normas vigentes no seu país.

T ABLE OF CONTENTS

PART 1 PRODUCT (GENERAL).....	1.
1.1-- <i>TECHNICAL SPECIFICATIONS</i>	1.
1.2-- <i>SAFETY WARNING</i>	2.
PART 2 INSTALLATION.....	3.
2.1-- <i>MOUNTING</i>	3.
2.2-- <i>SIGNAL CONNECTIONS</i>	3.
2.3-- <i>SETTING UP WITH A DMX512 CONTROLLER(STAGE 1 MODE)</i>	4.
PART 3 DISPLAY PANEL OPERATION.....	5.
3.1-- <i>BASIC</i>	5.
3.2-- <i>MENU</i>	5.
3.3-- <i>EDIT STATIC COLOUR</i>	6.
3.4-- <i>ACTIVATING AUTO PROGRAMS</i>	6.
3.5-- <i>RUN MODE</i>	6.
3.6-- <i>DMX512 SETTINGS</i>	7.
3.7-- <i>PERSONALITY</i>	7.
3.8-- <i>SPECIAL SETTINGS</i>	7.
3.9-- <i>ACTIVATE THE PASSWORD</i>	8.
3.10-- <i>BALANCE PARAMETERS AND CORRECTION MENU DISPLAY</i>	8.
PART 4 USING A DMX512 CONTROLLER.....	9.
4.1-- <i>BASIC ADDRESSING</i>	9.
4.2-- <i>CHANNEL ASSIGNMENT</i>	9.
PART 5 APPENDIX.....	13.
5.1-- <i>MAINTENANCE</i>	13.

1 PRODUCT (GENERAL)

1.1 TECHNICAL SPECIFICATIONS

LED MODULE

LED MODULE:	
Voltage	100~240V, 50/60Hz
Rated Power	16W
Model	12W LED(1xtri-RGBW)
Environment Temperature	-20°C~40°C
Cooling	Direct air convection
Dimensions	212 x 120 x 80mm
Weight	1.01Kg

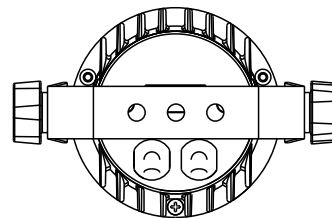
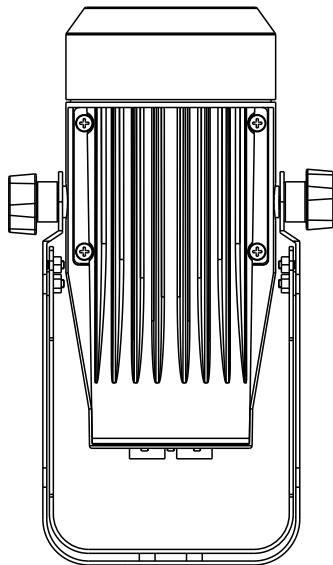
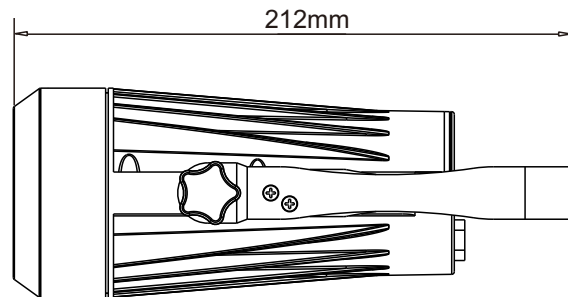
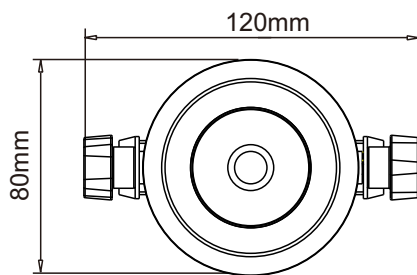

1.2 SAFETY WARNING

IMPORTANT

[ALWAYS READ THE USER MANUAL BEFORE OPERATION.]
[PLEASE CONFIRM THAT THE POWER SUPPLY STATED ON THE PRODUCT IS THE SAME AS THE MAINS POWER SUPPLY IN YOUR AREA.]

- This product must be installed by a qualified professional.
- Always operate the equipment as described in the user manual.
- A minimum distance of 0.5m must be maintained between the equipment and combustible surface.
- The product must always be placed in a well ventilated area.
- Always make sure that the equipment is installed securely.
- DO NOT stand close to the equipment and stare directly into the LED light source.
- Always disconnect the power supply before attempting and maintenance.
- Always make sure that the supporting structure is solid and can support the combined weight of the products.
- The earth wire must always be connected to the ground.
- Do not touch the power cables if your hands are wet.

ATTENTION



- This product left the place of manufacture in perfect condition. In order to maintain this condition and for safe operation, the user must always follow the instructions and safety warnings described in this user manual.
- Avoid shaking or strong impacts to any part of the equipment.
- Make sure that all parts of the equipment are kept clean and free of dust.
- Always make sure that the power connections are connected correct and secure.
- If there is any malfunction of the equipment, contact your distributor immediately.
- When transferring the product, it is advisable to use the original packaging in which the product left the factory.
- Shields, lenses or ultraviolet screens shall be changed if they have become damaged to such an extent that their effectiveness is impaired.
- The lamp (LED) shall be changed if it has become damaged or thermally deformed.

2 INSTALLATION

2.1 MOUNTING

UPRIGHT

The LED Fixture can be mounted in a sitting or wall mounted position using the supporting brackets. The LED Fixture should be placed on a non-flammable flat surface in any orientation and fixed by screws. There are four holes into the supporting bracket.

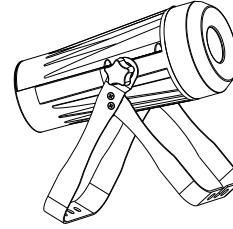

HANGING

The LED fixture can be mounted in a hanging position using the supporting bracket. The bracket should be secured to the mounting truss or structure using a standard mounting clamp. Please note that when hanging the unit a safety cable should also be used.

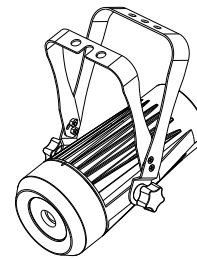

NOTE

The LED MODULE can be mounted at any angle and in any position. It is possible to further adjust the angle of the LED MODULE using the two adjustment knobs located on the side of the fixture.

2.2 SIGNAL CONNECTIONS

Note:

1. If over 25 units to be connected, then a DMX signal amplifier is needed.
2. If the signal cable is over 60m between the DMX512 controller and fixture or between two fixtures, then a DMX signal amplifier is needed as well.

2.3 SETTING UP WITH A DMX512 CONTROLLER(STAGE 1 MODE)

- Connect the DMX512 controller to the units in series.
- Each unit has 9 DMX channels so the DMX Addresses should increase by increments of 9 (e.g. 1,10,19,28...)
- Each DMX Address may be used as many times as required.
- Any DMX address in the range from 001 to 512 may be used.

Example:

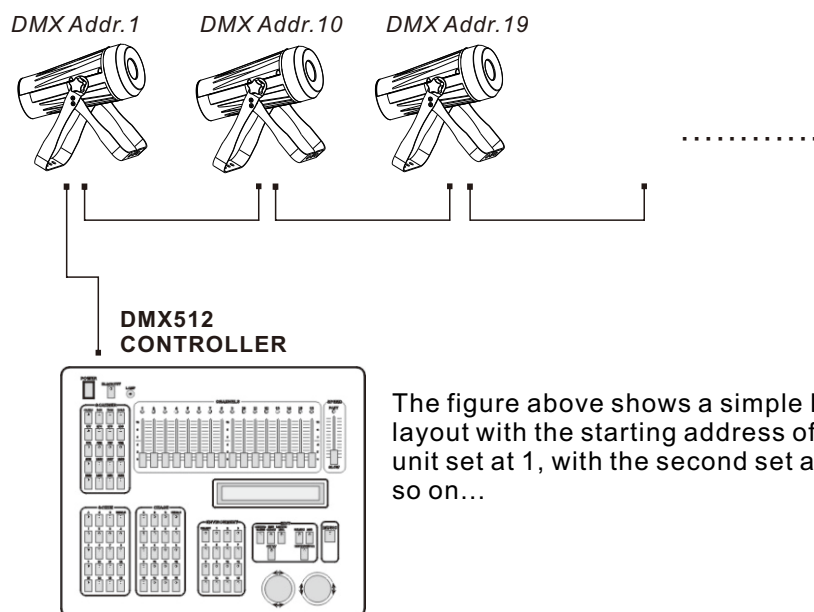

The figure above shows a simple DMX512 layout with the starting address of the first unit set at 1, with the second set at 10 and so on...

3 DISPLAY PANEL OPERATION

3.1 BASIC

- 【 ENTER 】 Choose one or return to the previous menu
- 【 UP 】 scroll 'UP' through the menu list or increase the value of the current function
- 【 DOWN 】 scroll 'DOWN' through the menu list or decrease the value of the current function

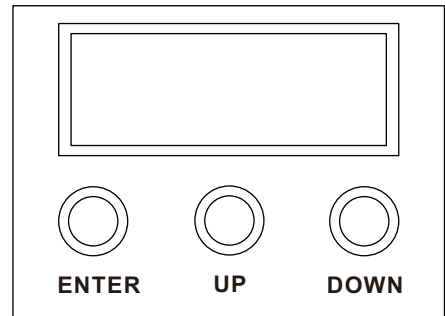

3.2 MENU

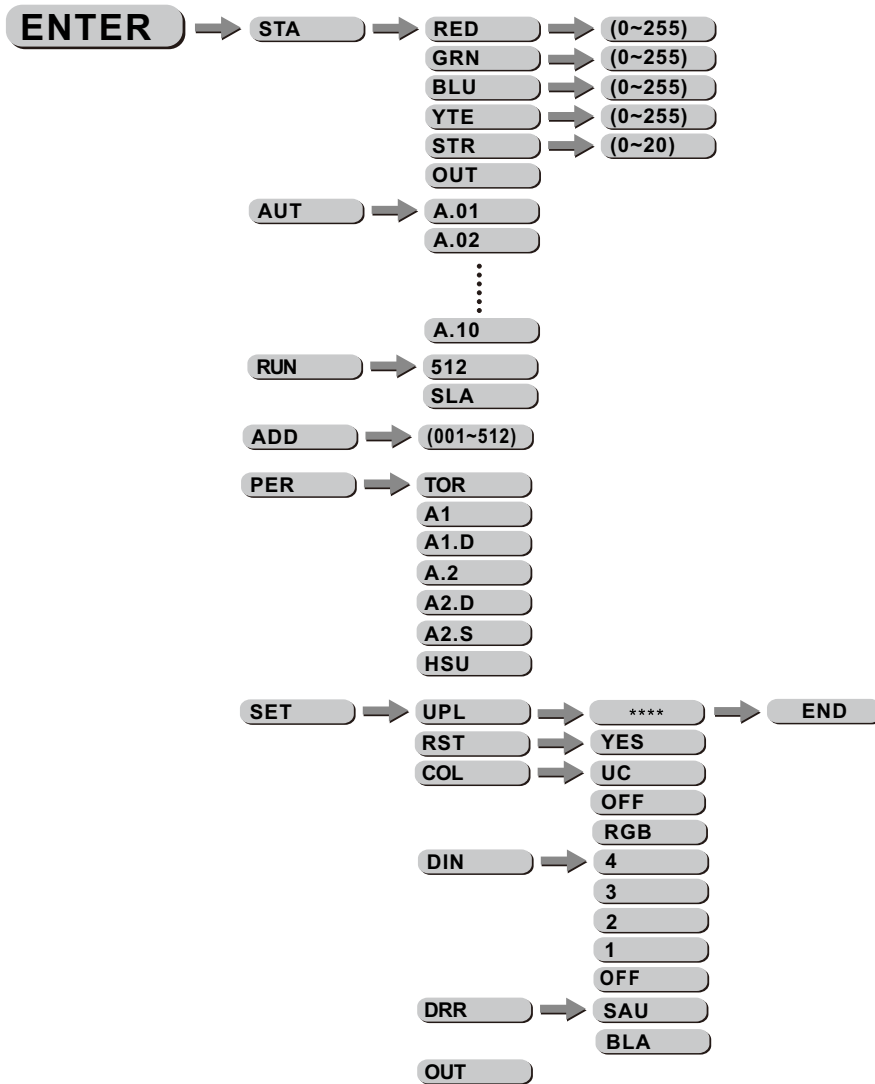

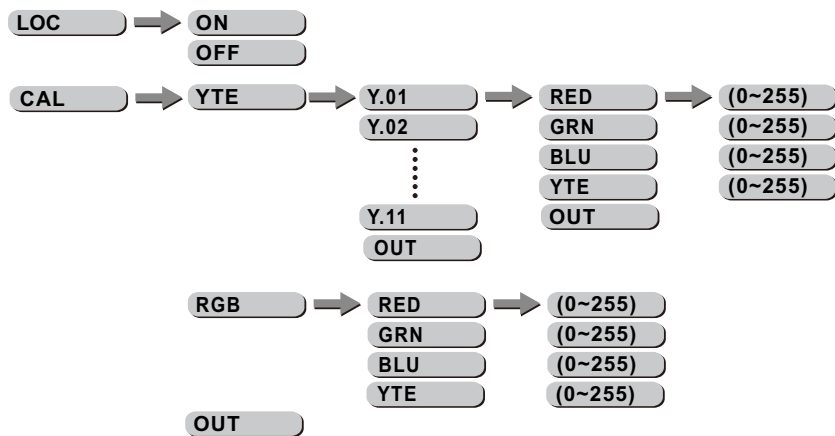

3.3 EDIT STATIC COLOUR

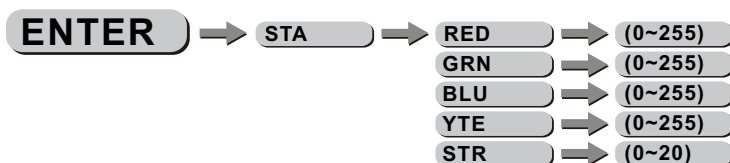

【STATIC COLOUR】

- Combine **【Red】** , **【Green】** , **【Blue】** and **【White】** to create an infinite range of colors (0-255)
- Set the value of the **【Strobe】** (0-20Hz)

3.4 ACTIVATING AUTO PROGRAMS

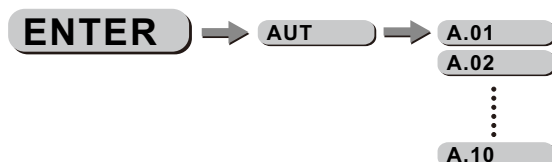

【AUTO】

- Select the target **【AUT】** program and press **【ENTER】** .
- Programs **【A.01】** to **【A.10】** are fully pre-programmed and will not be altered by changes in **【ENTER】** mode.

3.5 RUN MODE



【RUN】

- Enter the **【RUN】** mode to set working mode.
- **【DMX】** mode is for using the DMX512 controller to control the fixtures.
- **【SLA】** mode is for Master -- Slave operation.

3.6 DMX512 SETTINGS



【DMX】

- Enter the **【DMX】** mode to set the DMX ADD.

3.7 PERSONALITY



【PERSONALITY】

- Enter the **【PERSONALITY】** mode to select DMX mode: **【TOUR】** , **【A1】** , **【A1.D】** , **【A.2】** , **【A2.D】** , **【A2.S】** , **【HSU】** .

3.8 SPECIAL SETTINGS

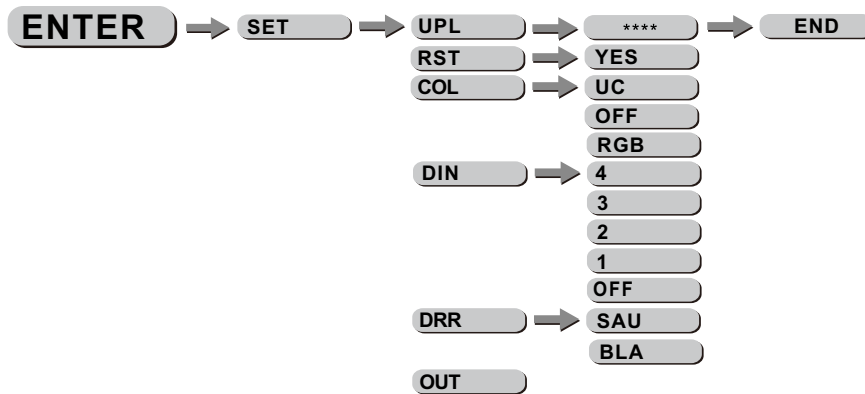

【SETTING】

- Select **【UPLD】** to upload the custom programs from the current MASTER unit to the SLAVE units.
- In order to activate the upload function the password must be entered.
- Password is the same as the main access password.
- When uploading the MASTER and SLAVE units will display YELLOW.
- If an error occurs when uploading the MASTER and/or SLAVE units will display RED.
- On successful uploading of the custom programs the MASTER and SLAVE units will display GREEN.
- In order to reset custom modes to default values select **【REST】** .
- **【COLOR】** is for activate/unactivate the color calibration functions.

When **【RGBW】** is selected, on RGB = 255,255,255, the color is displayed as calibrated in CAL2 -- RGBW. When **【COLOR】** is set **【OFF】** , on RGB = 255,255,255, the RGB values are not adjusted and the output is most powerful.

When **【UC】** is selected, the RGB output are adjusted to a standard preset universal color which balances fixtures from different generations.

- **【DERR】** Choose **【Save】** in order to save the last DMX data incase of DMX signal error. Choose **【Black】** in order to blackout in case of DMX signal error.

3.9 ACTIVATE THE PASSWORD



【LOC】

- Enter the **【LOC】** mode to select whether the access password is on or off.
- When the fixture is set as PASS **【ON】** , after 30 seconds or turn on the fixture next time, the fixture will need an access password to enter the display menu control.

Note: The factory access password is **【UP】 + 【DOWN】 + 【UP】 + 【DOWN】** , then press **【ENTER】** to confirm the access.

3.10 BALANCE PARAMETERS AND CORRECTION MENU DISPLAY

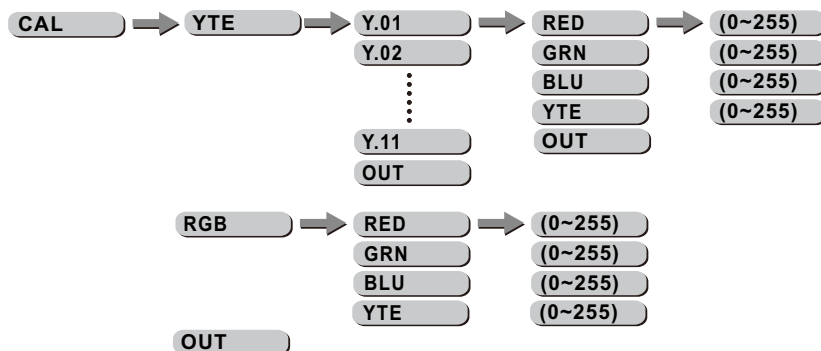

Press **【ENTER】** button to enter the password confirmation, to enter the correct password < UP + DOWN + UP + DOWN >
Key, press the **【ENTER】** in, the correct password will enter show submenu

【CAL】

- Enter the **【CAL】** to select white color of different color temperature.
- There are 11 pre-programmed White colors can be edited by using **【Red】** , **【Green】** , **【Blue】** & **【White】** .
- Enter the **【CAL】** to adjust the RGB parameter to make different whites.
- When the new setting is activated, the DMX controller choose RGB = 255,255,255 the white color will be made by the actual RGB values on the **【CAL】** .

4 CONTROL WITH A DMX512 CONTROLLER

4.1 BASIC ADDRESSING

- Connect all of the units in series using standard DMX512 signal cable.
- Set the DMX512 address in the DIP switch PCB.
- It is possible to have the same DMX address or independent addresses for each fixture.

4.2 CHANNEL ASSIGNMENT

Note: This product has three DMX512 channel configurations: **【STAGE1】** , **【ARC1】** and **【ARC2】** .

STAGE1

CHANNEL	VALUE	FUNCTION
1	0 ↔ 255	DIMMER
2	0 ↔ 255	RED
3	0 ↔ 255	GREEN
4	0 ↔ 255	BLUE
5	0 ↔ 255	WHITE
6	0 ↔ 10	COLOR MACRO NO FUNCTION
	11 ↔ 30	RED 100% / GREEN UP / BLUE 0%
	31 ↔ 50	RED DOWN / GREEN 100% / BLUE 0%
	51 ↔ 70	RED 0% / GREEN 100% / BLUE UP
	71 ↔ 90	RED 0% / GREEN DOWN / BLUE 100%
	91 ↔ 110	RED UP / GREEN 0% / BLUE 100%
	111 ↔ 130	RED 100% / GREEN 0% / BLUE DOWN
	131 ↔ 150	RED 100% / GREEN UP / BLUE UP
	151 ↔ 170	RED DOWN / GREEN DOWN / BLUE 100%
	171 ↔ 200	RED 100% / GREEN 100% / BLUE 100%WHITE100%
	201 ↔ 205	WHITE 1: 3200K
	206 ↔ 210	WHITE 2: 3400K
	211 ↔ 215	WHITE 3: 4200K
	216 ↔ 220	WHITE 4: 4900K

CHANNEL	VALUE	FUNCTION
6	221 ↔ 225	WHITE 5: 5600K
	226 ↔ 230	WHITE 6: 5900K
	231 ↔ 235	WHITE 7: 6500K
	236 ↔ 240	WHITE 8: 7200K
	241 ↔ 245	WHITE 9: 8000K
	246 ↔ 250	WHITE 10: 8500K
	251 ↔ 255	WHITE 11: 10000K
7	0 ↔ 10	STROBE NO FUNCTION
	11 ↔ 255	FROM SLOW TO FAST
8	0 ↔ 40	AUTO NO FUNCTION
	41 ↔ 50	AUTO1
	51 ↔ 60	AUTO2
	61 ↔ 70	AUTO3
	71 ↔ 80	AUTO4
	81 ↔ 90	AUTO5
	91 ↔ 100	AUTO6
	101 ↔ 110	AUTO7
	111 ↔ 120	AUTO8
	121 ↔ 130	AUTO9
131 ↔ 255	AUTO10	
9	0 ↔ 255	AUTO SPEED ADJUSTMENT

Arc.1

CHANNEL	VALUE	FUNCTION
1	0 ↔ 255	RED
2	0 ↔ 255	GREEN
3	0 ↔ 255	BLUE

Ar1.d

CHANNEL	VALUE	FUNCTION
1	0 ↔ 255	MASTER DIMMER
2	0 ↔ 255	RED
3	0 ↔ 255	GREEN
4	0 ↔ 255	BLUE

Arc.2

CHANNEL	VALUE	FUNCTION
1	0 ↔ 255	RED
2	0 ↔ 255	GREEN
3	0 ↔ 255	BLUE
4	0 ↔ 255	WHITE

Ar2.d

CHANNEL	VALUE	FUNCTION
1	0 ↔ 255	MASTER DIMMER
2	0 ↔ 255	RED
3	0 ↔ 255	GREEN
4	0 ↔ 255	BLUE
5	0 ↔ 255	WHITE

Ar2.s

CHANNEL	VALUE	FUNCTION
1	0 ↔ 255	MASTER DIMMER
2	0 ↔ 255	RED
3	0 ↔ 255	GREEN
4	0 ↔ 255	BLUE
5	0 ↔ 255	WHITE
6	0 ↔ 255	STROBE

HSV

CHANNEL	VALUE	FUNCTION
1	0 ↔ 255	HUE(0~100%)
2	0 ↔ 255	SATURATION(0~100%)
3	0 ↔ 255	VALUE(0~100%)

5 APPENDIX

5.1 MAINTENANCE

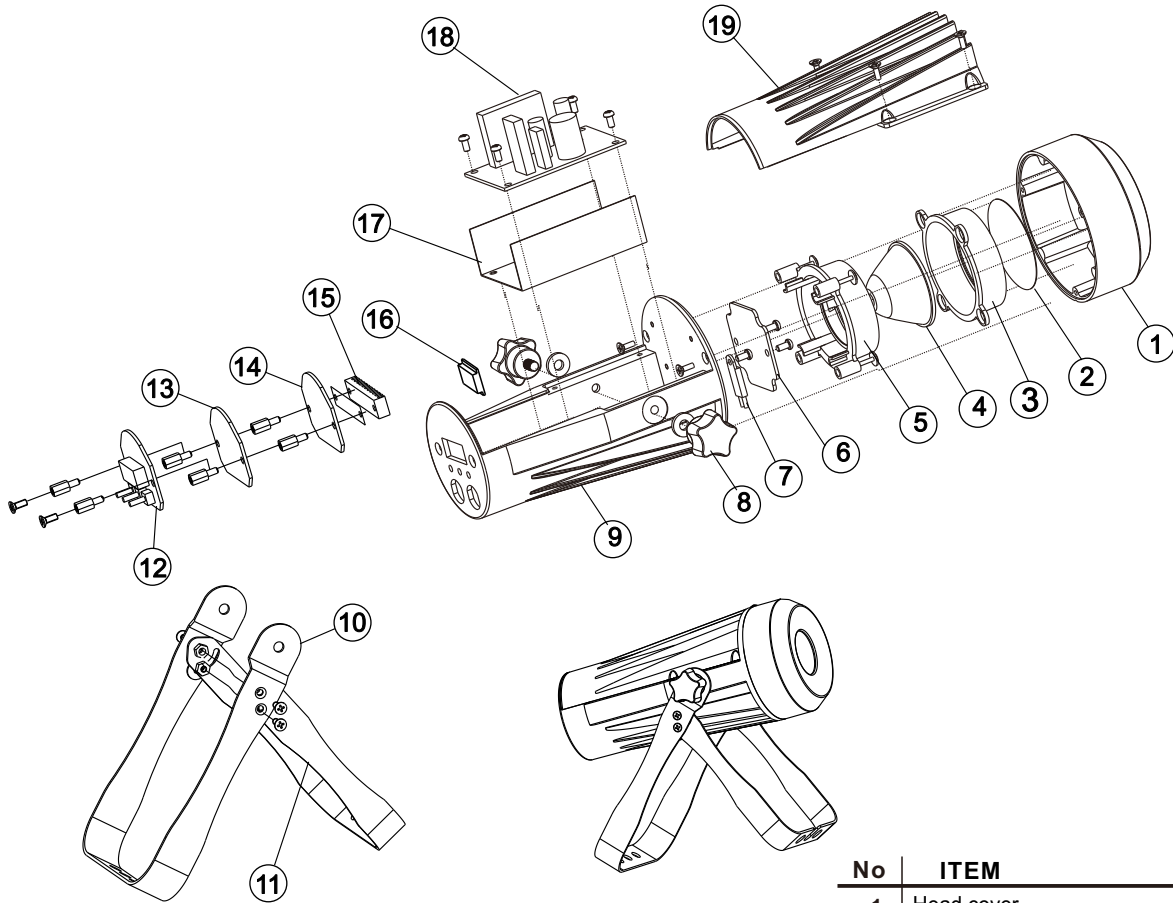

No	ITEM
1	Head cover
2	Abrazine slice
3	Lens frame2
4	Lens
5	Lens frame 1
6	LED board
7	Thermal protection device
8	Screw
9	Head casing main section1
10	Bracket 1
11	Bracket 2
12	Display PCB
13	Control board
14	Prive PCB
15	Heat sink
16	Display glass
17	Isolator sheet
18	Power supply
19	Head casing main section2