

Information

Power Parts

62014910033

01. 2012

3.211.832



*KTM Sportmotorcycle AG
Stallhofnerstraße 3
A-5230 Mattighofen
www.ktm.com*

KTM **POWERPARTS**

Danke, dass Sie sich für KTM Power Parts entschlossen haben.

Alle unsere Produkte wurden nach den höchsten Standards entwickelt und gefertigt, unter Verwendung der besten verfügbaren Materialien.

KTM Power Parts sind rennerprobt und gewährleisten ultimative Performance.

KTM KANN NICHT VERANTWORTLICH GEMACHT WERDEN FÜR FALSCHES MONTAGE ODER VERWENDUNG DIESES PRODUKTS. Bitte befolgen Sie die Montageanleitung. Fachmännische Beratung und korrekte Installation der KTM PowerParts durch einen autorisierten KTM Händler sind unerlässlich, um das Optimum an Sicherheit und Funktionalität zu gewährleisten.

Danke.

Thank you for choosing KTM Power Parts!

All of our products are designed and built to the highest standards using the finest materials available.

KTM Power Parts are race proven to offer the ultimate in performance.

KTM WILL NOT BE HELD LIABLE FOR IMPROPER INSTALLATION OR USE OF THIS PRODUCT. Please follow all instructions provided. Professional advice and proper installation of the KTM PowerParts by an authorized KTM dealer are essential to provide maximum safety and functions.

Thank you.

Grazie per aver deciso di acquistare un prodotto KTM Power Parts.

Tutti i nostri prodotti sono stati sviluppati e realizzati secondo i massimi standard e con l'impiego dei migliori materiali disponibili.

Le KTM Power Parts sono collaudate nelle competizioni ed assicurano altissime prestazioni.

KTM NON PUÒ ESSERE RESA RESPONSABILE PER UN MONTAGGIO O USO IMPROPRIO DI QUESTO PRODOTTO. Per favore osservate le istruzioni nel manuale d'uso. Al fine di garantire la massima sicurezza e il corretto funzionamento, è indispensabile farsi consigliare da persone esperte e competenti e far eseguire l'installazione delle KTM PowerPart presso i concessionari KTM autorizzati.

Grazie.

Nous vous remercions d'avoir choisi KTM Power Parts.

Tous nos produits ont été développés et réalisés selon les plus hauts standards et en utilisant les meilleurs matériaux disponibles.

Les Power Parts de KTM ont fait leurs preuves en compétition et garantissent les meilleures performances.

LA RESPONSABILITÉ DE KTM NE SAURAIT ÊTRE ENGAGÉE EN CAS D'ERREUR DANS LE MONTAGE OU L'UTILISATION DE CE PRODUIT.

Il convient de respecter les instructions de montage.

Le conseil spécialisé et l'installation dans les règles de l'art des PowerParts KTM par un concessionnaire KTM agréé sont indispensables pour assurer un maximum de sécurité et de fonctionnalité.

Merci.

Gracias por haberse decidido por el Power Parts KTM.

Todos nuestros productos han sido desarrollados y producidos según los estándares más altos utilizando los mejores materiales disponibles.

Las KTM Power Parts están probadas en competencia y garantizan un óptimo rendimiento.

NO SE PUEDE HACER RESPONSABLE A LA KTM POR UN MONTAJE O UN USO INCORRECTO DE ESTE PRODUCTO.

Le rogamos seguir las instrucciones para el montaje.

A fin de garantizar la máxima seguridad y un funcionamiento correcto es imprescindible acudir a un concesionario autorizado de KTM para obtener el mejor asesoramiento técnico e instalar correctamente las KTM PowerParts.

Gracias.

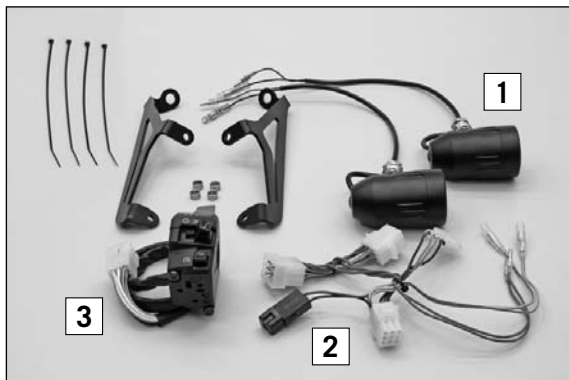
**Lieferumfang:**

- 1x Zusatzscheinwerfer (1)
- 1x Adapterkabelstrang Zusatzscheinwerfer (2)
- 1x Montagekit
- 1x Start-Notaus Licht Schalter (3)

60114910000
62011910000
62014910044
60011074000

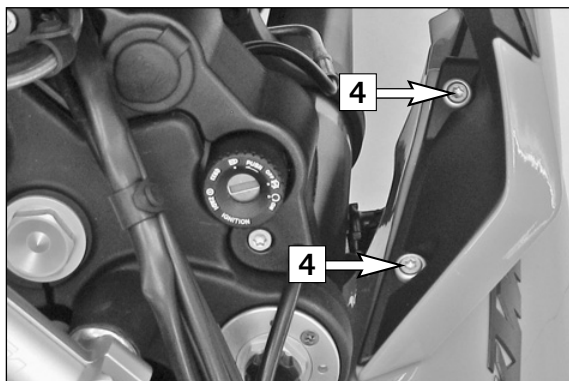
**Vorarbeiten**

- Maskenspoiler ausbauen.
- Schrauben (4) beidseitig entfernen.

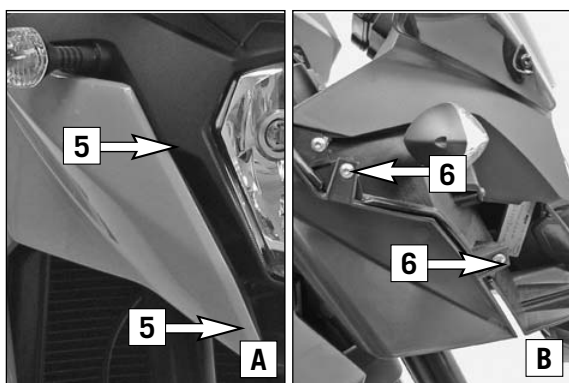

- Schrauben (5) beidseitig entfernen (Bild A).
- Schrauben (6) beidseitig entfernen (Bild B).

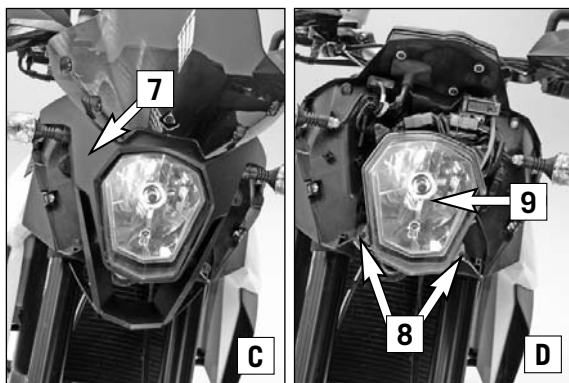

- Sämtliche Schrauben der Scheinwerfermaske (7) entfernen und Scheinwerfermaske (7) abnehmen (Bild C).
- Schrauben (8) entfernen und Scheinwerfer (9) vorsichtig nach vorne ablegen (Bild D).

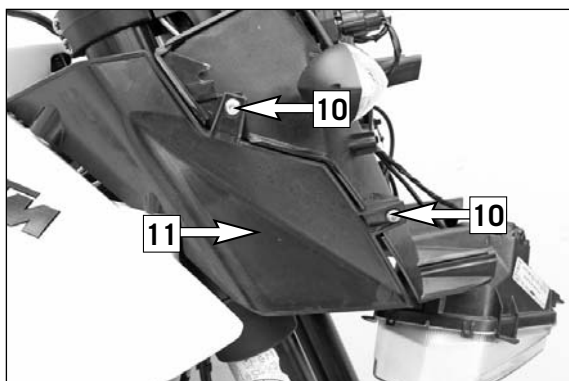

- Schrauben (10) beidseitig entfernen und Maskenspoiler Innenteil (11) abnehmen.

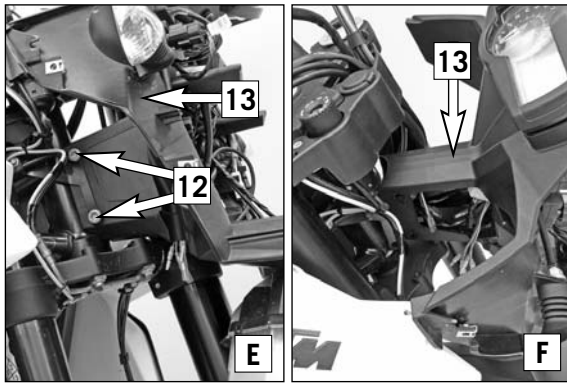

- Schrauben (12) beidseitig entfernen (Bild E) und Cockpitträger (13) nach vorne ablegen (Bild F).

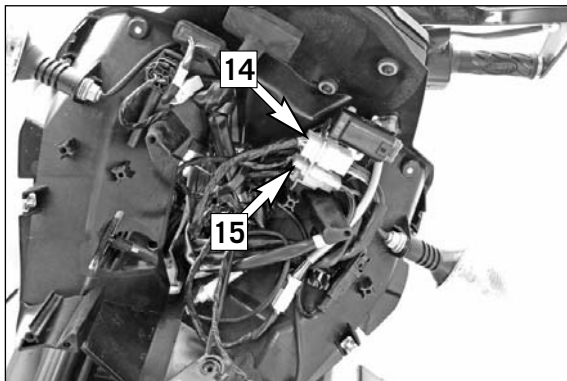

- Stecker (14) und (15) abstecken.

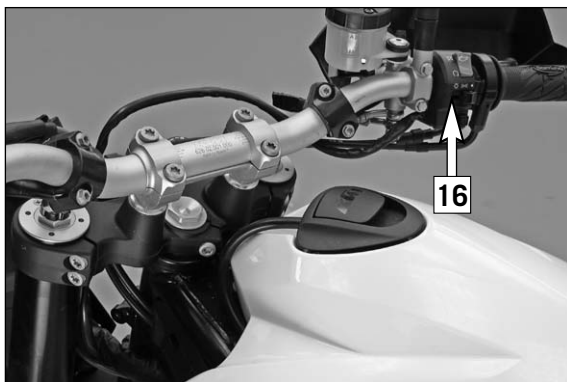

Montage

! VORSICHT

Sämtliche Drehmomente siehe Bedienungsanleitung.

- Original Schaltamatur (16) demontieren und Start-Notaus Licht Schalter (3) (Lieferumfang) montieren.
- Kabel des Start-Notaus Licht Schalters (3) wie Original Schaltamatur verlegen.

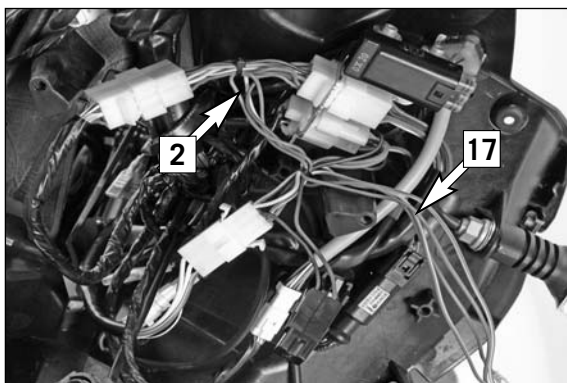

- Adapterkabelstrang Zusatzscheinwerfer (2) anschließen.
- Sämtliche Stecker am Adapterkabelstrang Zusatzscheinwerfer (2) anschließen.

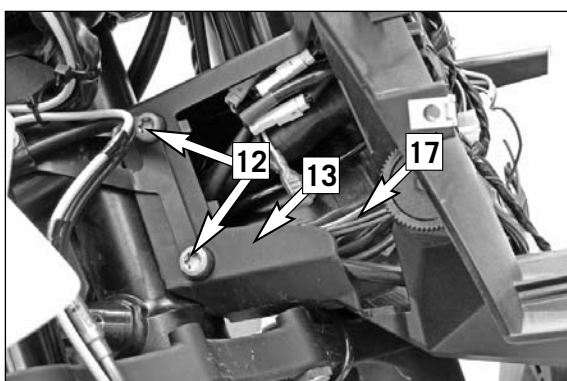

- Cockpitträger (13) positionieren und mit den Original Schrauben M8x20 (12) befestigen.
- Kabelanschluss (17) der Zusatzscheinwerfer nach hinten verlegen.

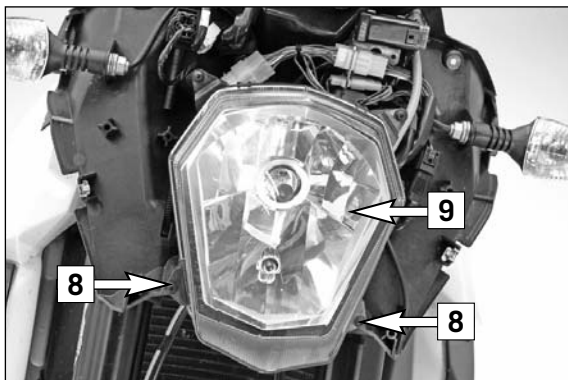

- Scheinwer (9) positionieren und mit den Original Schrauben (8) montieren.

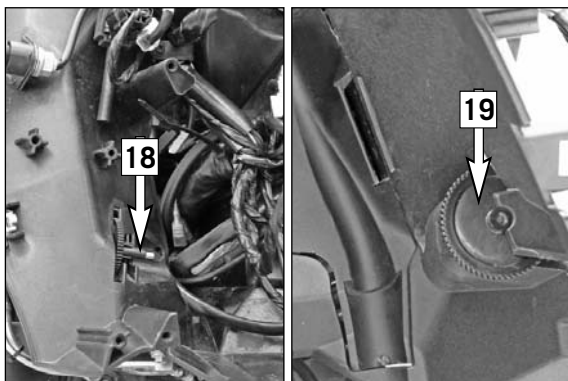

! VORSICHT

Bei der Montage des Scheinwerfers auf die Führung (18) der Scheinwerfereinstellung (19) achten.

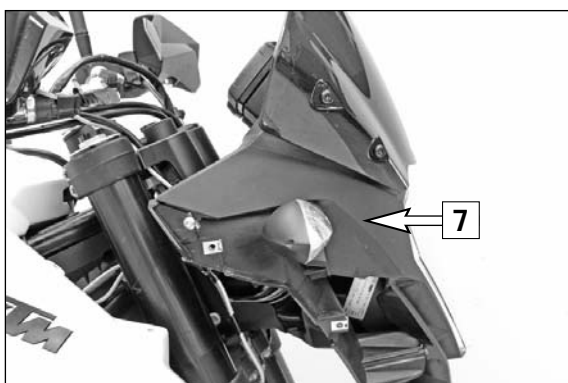

- Scheinwerfermaske (7) montieren.

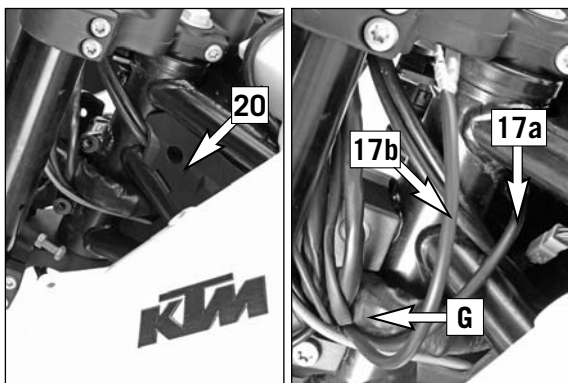

- Abdeckung (20) beidseitig demontieren.
- Kabel (17) an Position (G) hinter den Steuerkopf verlegen.
- Kabel (17a) durch den Rahmen nach rechts verlegen (Anschluss für rechten Zusatzscheinwerfer).

HINWEIS:

Kabel (17b) bleibt auf der linken Seite (Anschluss für linken Zusatzscheinwerfer).

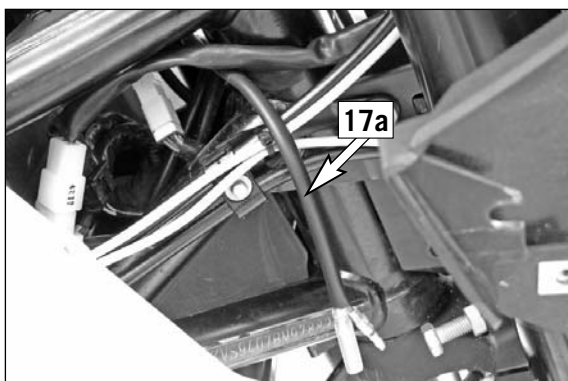

! VORSICHT

Sämtliche Kabel ordnungsgemäß verlegen und mit Kabelbinder sichern. Sicherstellen, dass die Kabel nicht geknickt oder geklemmt werden können

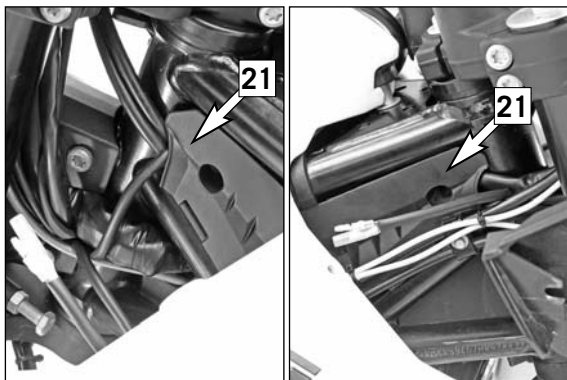

- Abdeckungen (20) links und rechts wieder montieren.

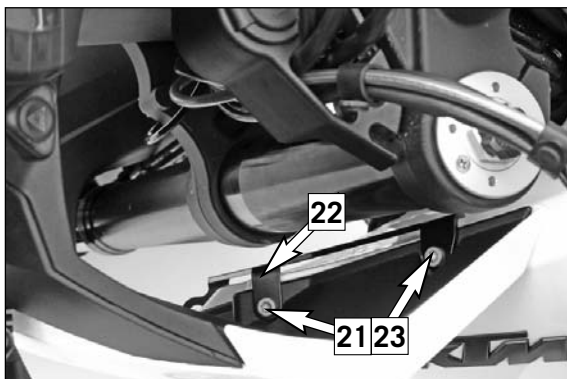

- Buchsen (21) (Lieferumfang) für Halter Zusatzscheinwerfer links und rechts einsetzen.

- Halter Zusatzscheinwerfer links (22) positionieren und mit dem Maskenspoiler und den Original Schrauben (23) links montieren.

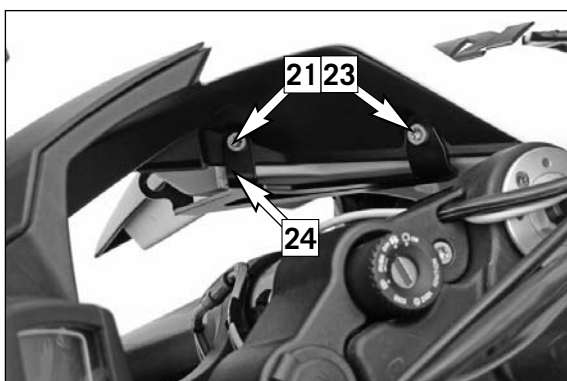

- Halter Zusatzscheinwerfer rechts (24) positionieren und mit dem Maskenspoiler und den Original Schrauben (23) rechts montieren.

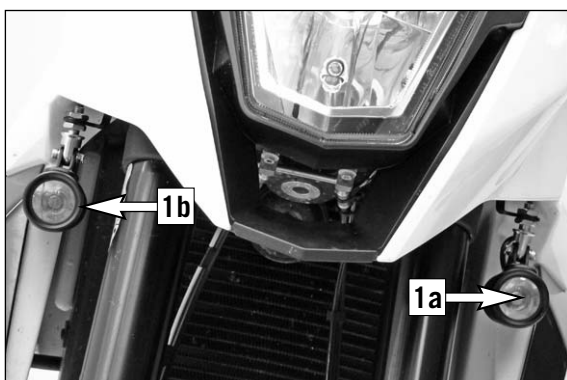

- Zusatzscheinwerfer links (1a) und rechts (1b) an den Haltern montieren.

HINWEIS:
Montage siehe Bild (H)

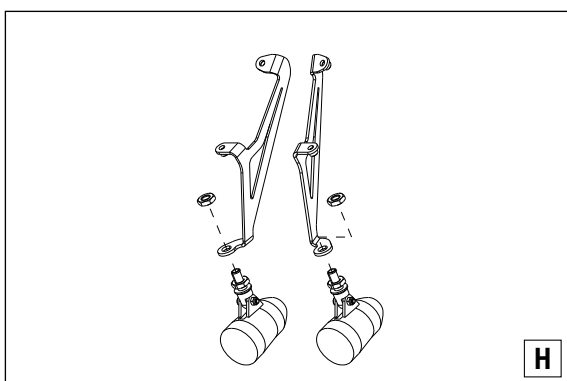

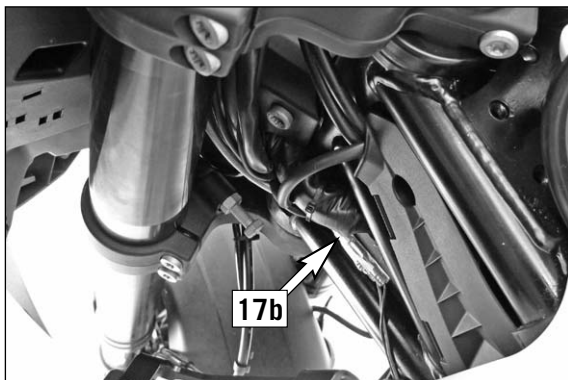

- Kabel der Zusatzscheinwerfer links und rechts verlegen und am Kabel (17a) und (17b) anstecken.

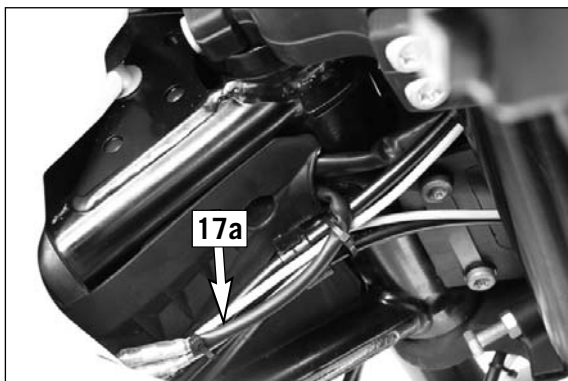

! VORSICHT

Sämtliche Kabel ordnungsgemäß verlegen und mit Kabelbinder sichern. Sicherstellen, dass die Kabel nicht geknickt oder geklemmt werden können.

⚠ ACHTUNG

Funktionsprüfung der Lichtanlage (Scheinwerfer, Blinker) durchführen.

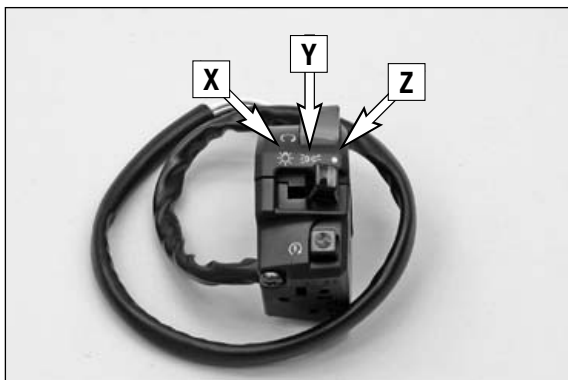

Funktion Start-Notaus Licht Schalter

Position (X)	Zusatzscheinwerfer ein
Position (Y)	Zusatzscheinwerfer ein, wenn Fernlicht eingeschaltet wird
Position (Z)	Zusatzscheinwerfer aus

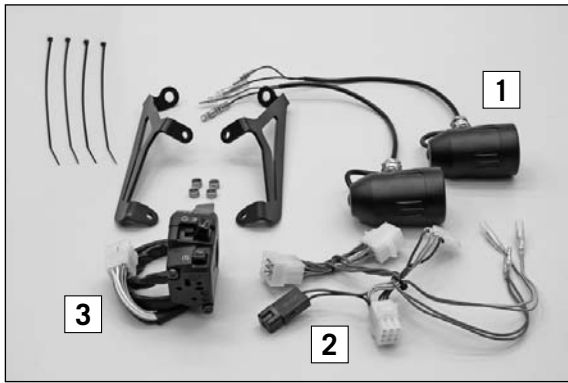

Scope of supply:

- | | |
|---|-------------|
| 1x supplementary headlight (1) | 60114910000 |
| 1x adapter wiring harness for supplementary headlight (2) | 62011910000 |
| 1x assembly kit | 62014910044 |
| 1x start emergency-off light switch (3) | 60011074000 |

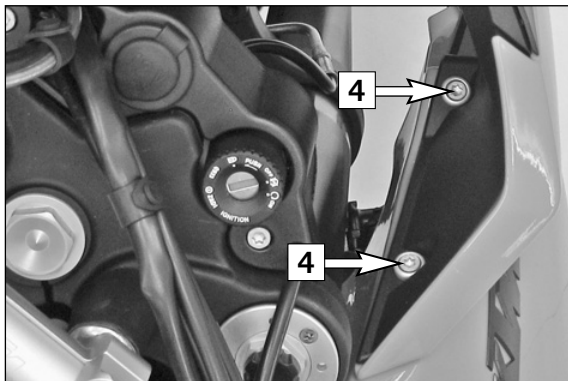

Preparations

- Remove the mask spoiler.
- Remove the screws (4) on both sides.

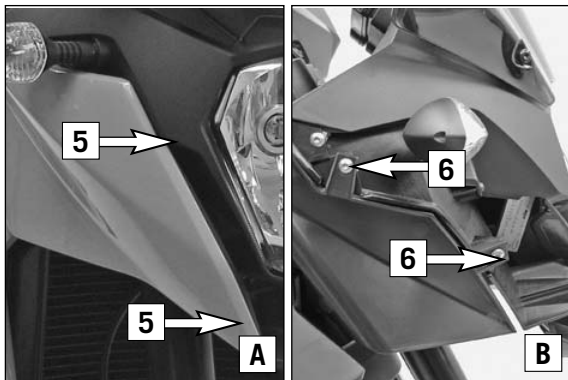

- Remove the screws (5) on both sides (Figure A).
- Remove the screws (6) on both sides (Figure B).

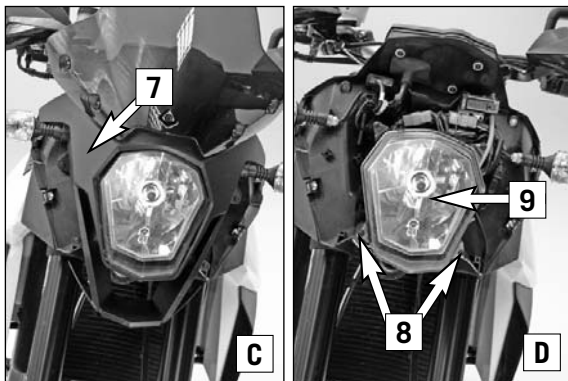

- Remove all screws of the headlight mask (7) and take off the headlight mask (7) (Figure C).
- Remove the screws (8) and carefully set down the headlight (9) toward the front (Figure D).

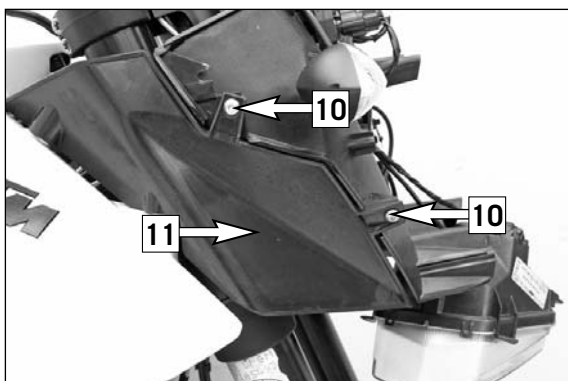

- Remove the screws (10) on both sides and take off the inside part (11) of the mask spoiler.

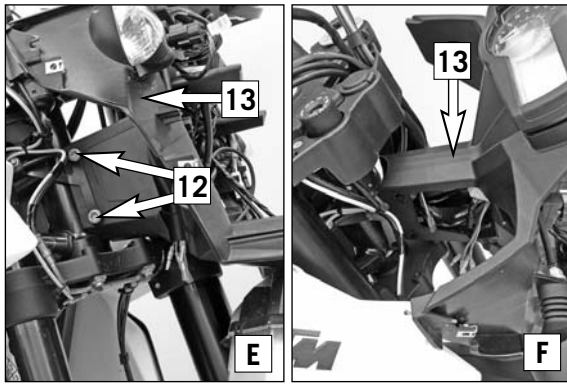

- Remove the screws (12) on both sides (Figure E) and set down the cockpit holder (13) toward the front (Figure F).

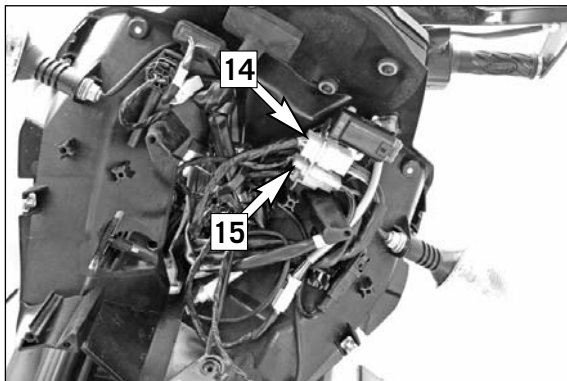

- Disconnect connectors (14) and (15).

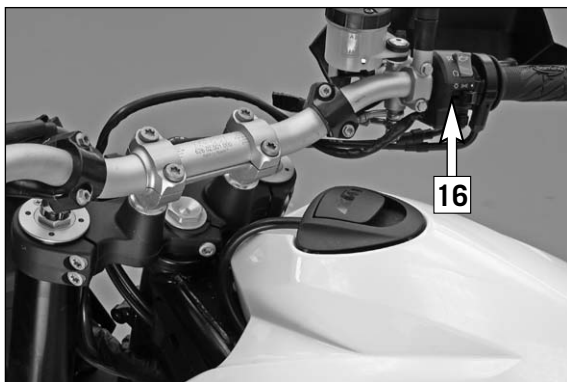

Assembly

! CAUTION

See the Owner's Manual for all torques.

- Remove the original switch element (16) and mount the start emergency-off light switch (3), which is included.
- Route the cable of the start emergency-off light switch (3) as it was for the original switch element.

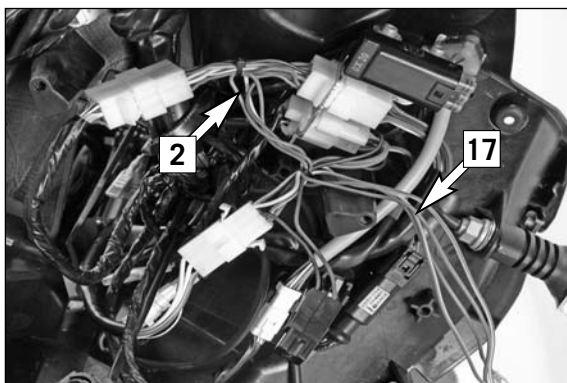

- Connect the adapter wiring harness for the supplementary headlight (2).
- Connect all connectors to the adapter wiring harness for the supplementary headlight (2).

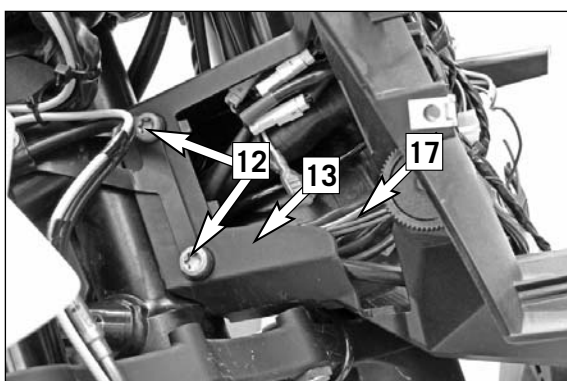

- Position the cockpit holder (13) and secure it with the original screws M8x20 (12).
- Route the cable connector (17) of the supplementary headlight toward the rear.

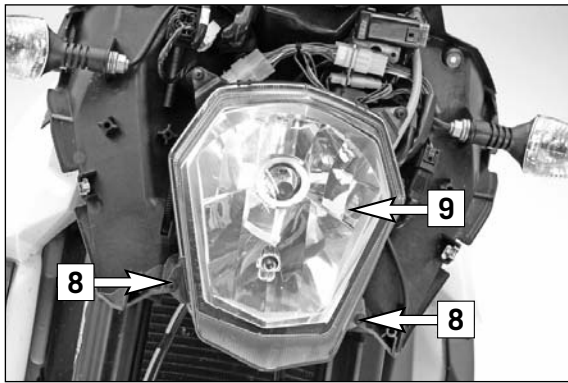

- Position the headlight (9) and mount it with the original screws (8).

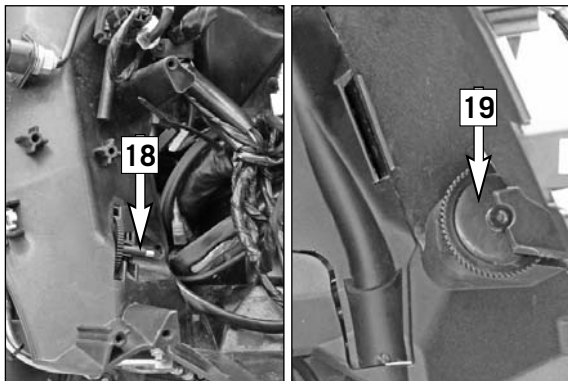

! CAUTION

When mounting the headlight, pay attention to the guide (18) of the headlight adjuster (19).

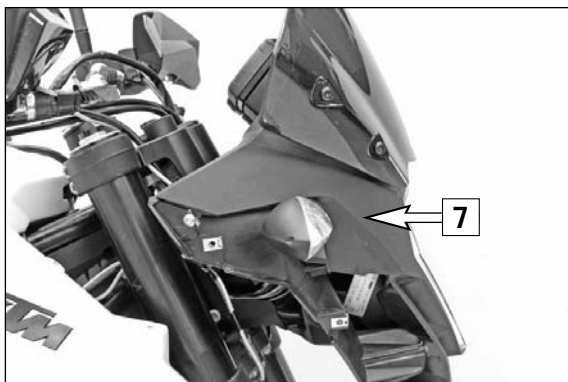

- Mount the headlight mask (7).

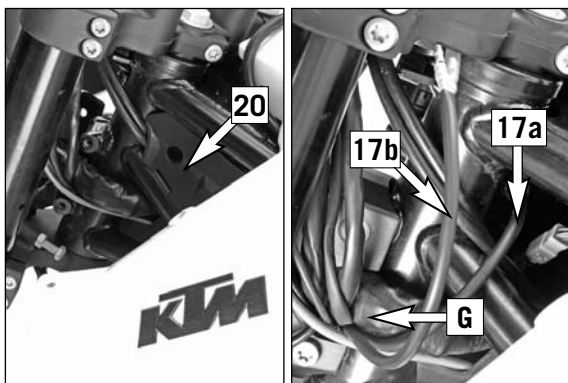

- Remove the cover (20) on both sides.

- Lay the cable (17) at position (G) behind the steering head.

- Lay the cable (17a) through the frame toward the right (connection for the right supplementary headlight).

NOTE:

The cable (17b) stays on the left side (connection for the left supplementary headlight).

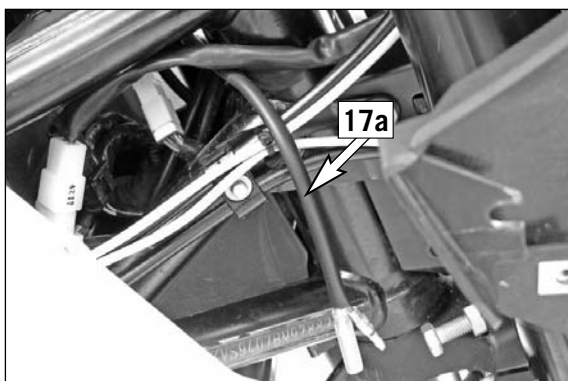

! CAUTION

Properly route all cables and secure them with cable ties. Ensure that the cables can be neither kinked nor pinched.

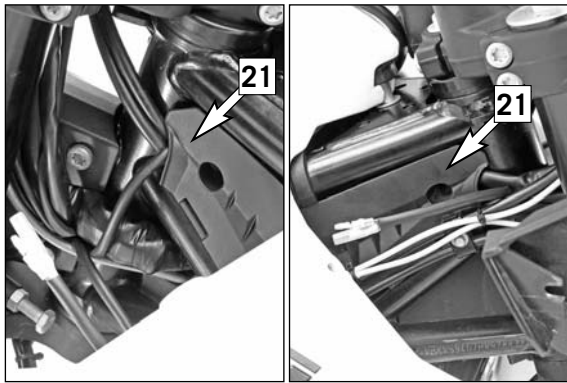

- Mount the left and right covers (20) again.

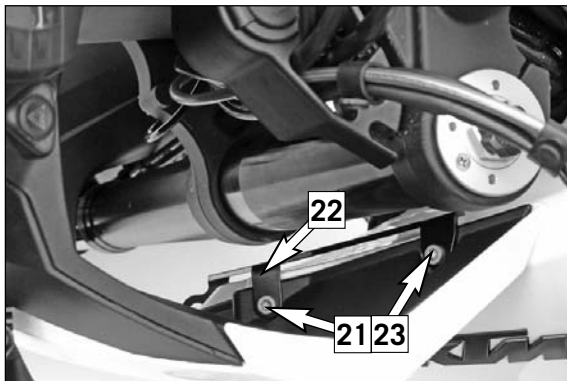

- Insert the bushings (21) (included) for the supplementary headlight holder on the left and right.

- Position the supplementary headlight holder on the left (22) and mount it on the left with the mask spoiler and the original screws (23).

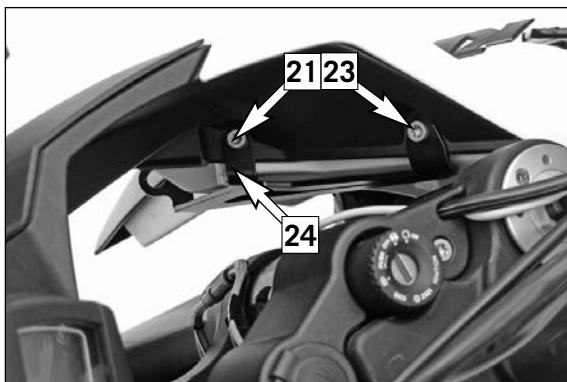

- Position the supplementary headlight holder on the right (24) and mount it on the right with the mask spoiler and the original screws (23).

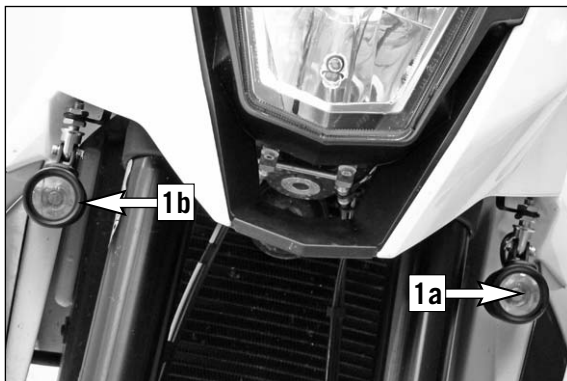

- Mount the supplementary headlights on the left (1a) and right (1b) on the holders.

NOTE:
Installation, see Figure (H)

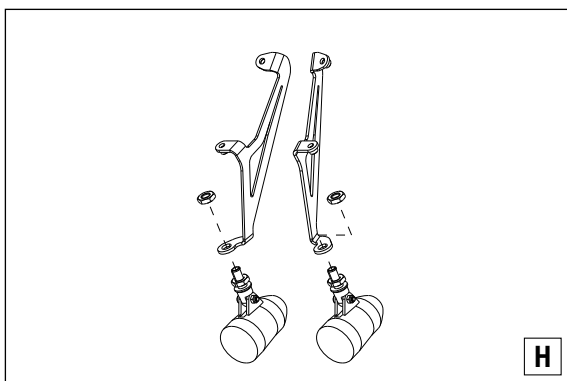

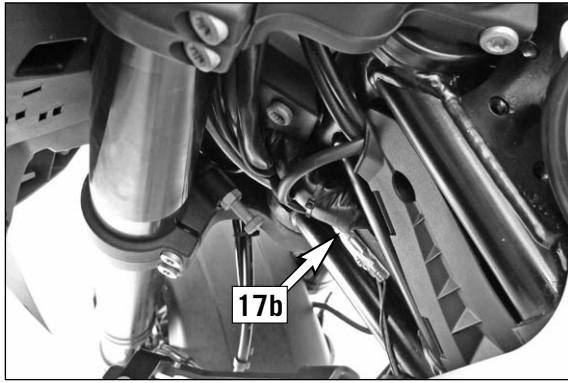

- Route the cables for the supplementary headlights on the left and right and connect to cables (17a) and (17b).

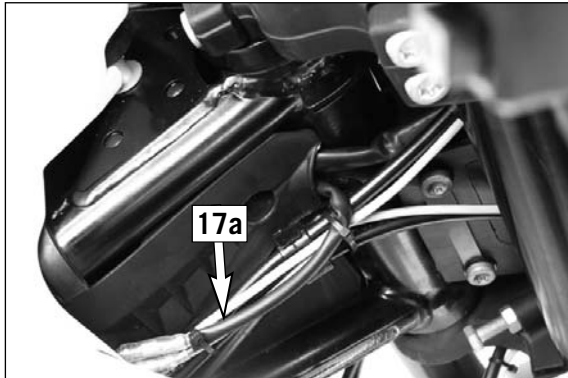

! CAUTION

Properly route all cables and secure them with cable ties. Ensure that the cables can be neither kinked nor pinched.

⚠ WARNING

Check that the lighting system (headlight, turn signal) is functioning properly.

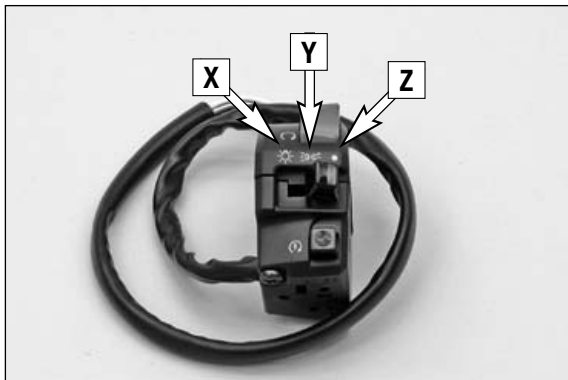

Function of the start emergency-off light switch

- Position (X) Supplementary headlight is on
- Position (Y) Supplementary headlight is on when the high beam is switched on
- Position (Z) Supplementary headlight is off

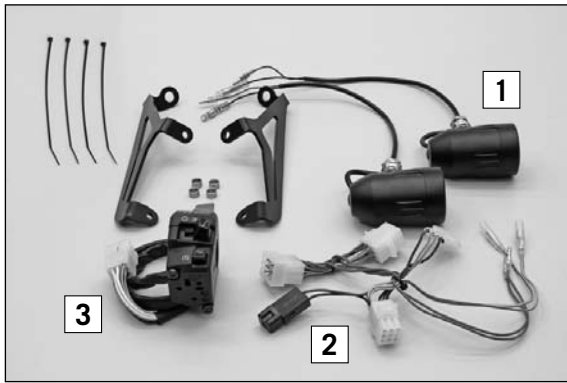

Volume della fornitura:

- N. 1 faro supplementare (1) 60114910000
- N. 1 fascio cavi adattatore per il faro supplementare (2) 62011910000
- N. 1 kit di montaggio 62014910044
- N. 1 interruttore di avviamento, di sicurezza e faro (3) 60011074000

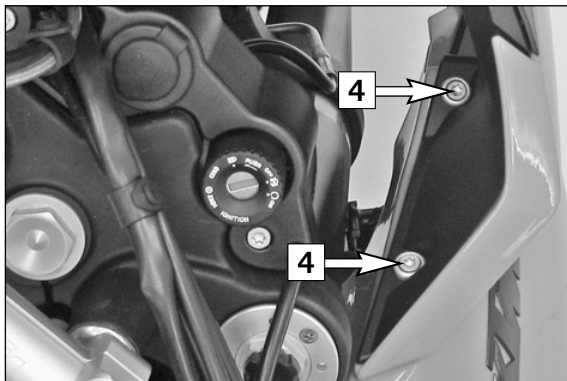

Operazioni preliminari

- Smontare lo spoiler della mascherina.
- Togliere le viti (4) da entrambi i lati.

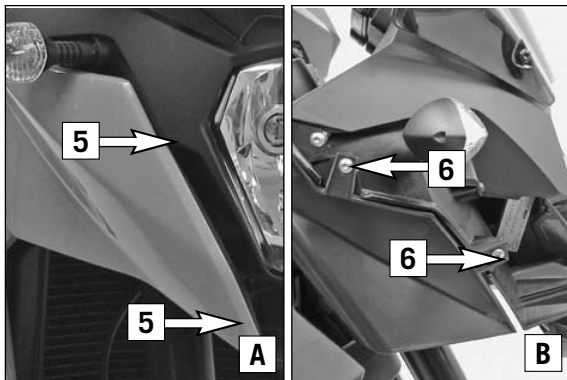

- Togliere le viti (5) da entrambi i lati (figura A).
- Togliere le viti (6) da entrambi i lati (figura B).

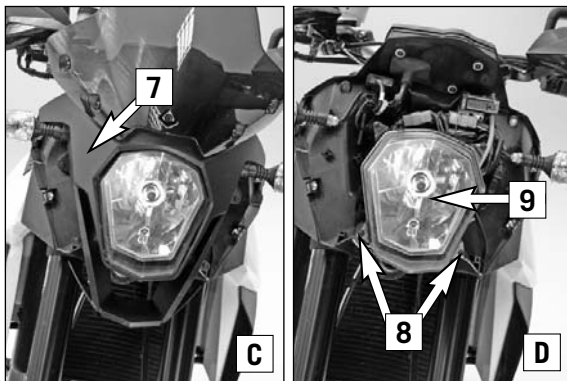

- Togliere tutte le viti della mascherina portafaro (7), quindi rimuovere la mascherina portafaro (7) (figura C).
- Togliere le viti (8) e ribaltare con cautela il faro (9) in avanti (figura D).

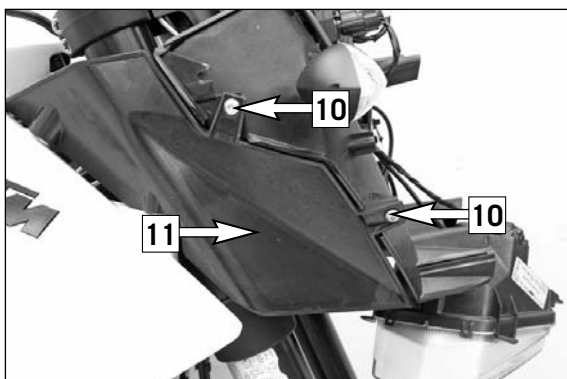

- Togliere le viti (10) da entrambi i lati e rimuovere la parte interna dello spoiler della mascherina (11).

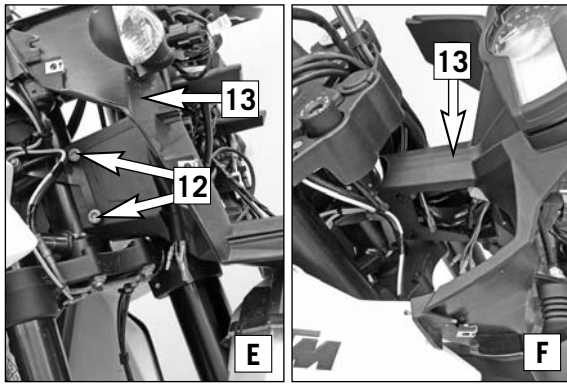

- Togliere le viti (12) da entrambi i lati (figura E) e ribaltare in avanti il supporto del cruscotto (13) (figura F).

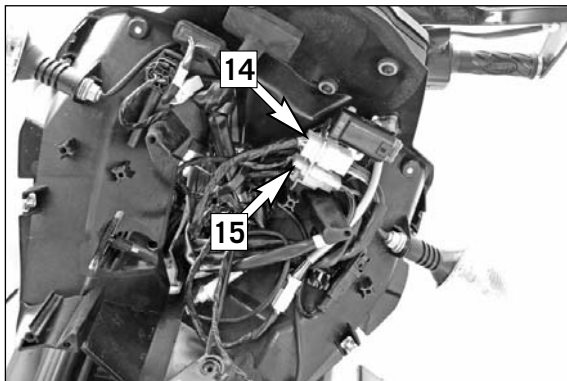

- Scollegare i connettori (14) e (15).

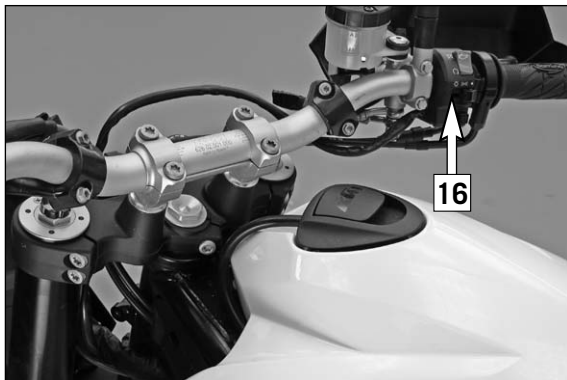

Montaggio

! AVVERTIMENTO

Per informazioni sulle coppie di serraggio vedere il manuale d'uso.

- Smontare l'unità originale dell'interruttore (16) e montare l'interruttore di avviamento, di sicurezza e faro (3) (in dotazione).
- Disporre il cavo dell'interruttore di avviamento, di sicurezza e faro (3) come nell'unità originale dell'interruttore.

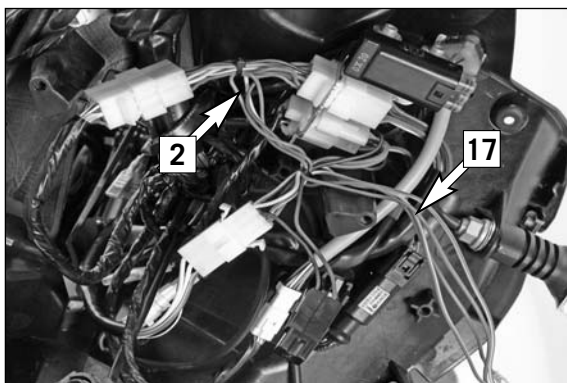

- Collegare il fascio cavi adattatore del faro supplementare (2).
- Collegare tutti i connettori al fascio cavi adattatore del faro supplementare (2).

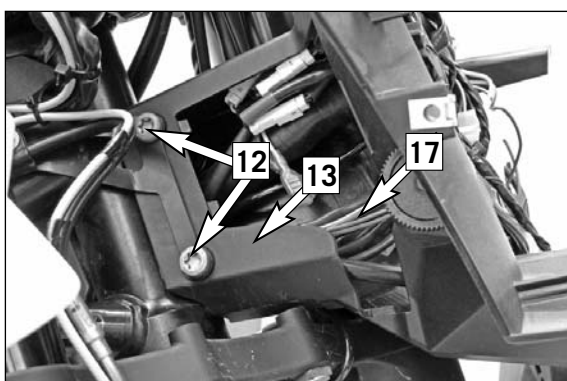

- Posizionare il supporto del cruscotto (13) e fissarlo con le viti originali M8x20 (12).
- Disporre il cavo di collegamento (17) del faro supplementare verso la parte posteriore del veicolo.

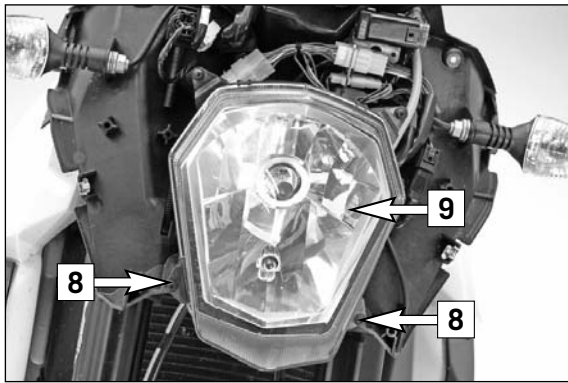

- Posizionare il faro (9) e montarlo con le viti (8) originali.

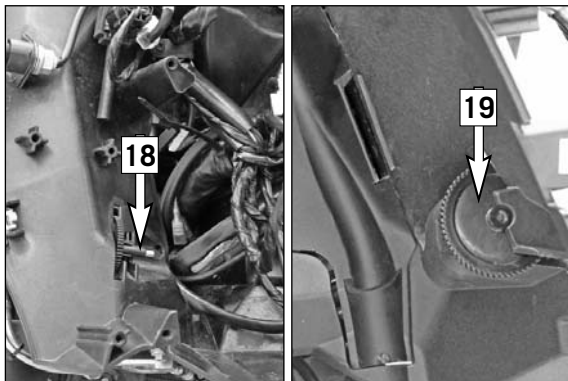

! AVVERTIMENTO

Nel montare il faro prestare attenzione alla guida (18) del dispositivo di orientamento del faro (19).

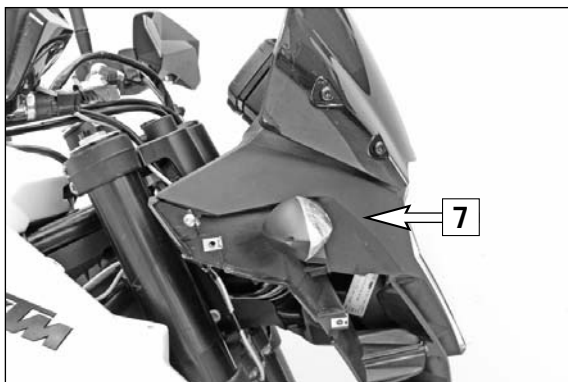

- Montare la mascherina portafaro (7).

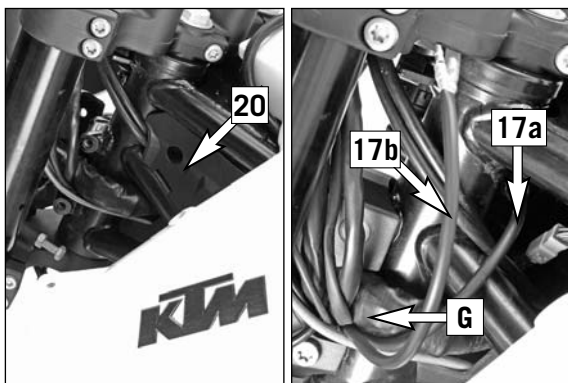

- Smontare la copertura (20) su entrambi i lati.

- Disporre il cavo (17) in posizione (G) dietro il canotto di sterzo.

- Far passare il cavo (17a) attraverso il telaio verso destra (collegamento per il faro supplementare di destra).

NOTA:

Il cavo (17b) rimane sul lato sinistro (collegamento per il faro supplementare di sinistra).

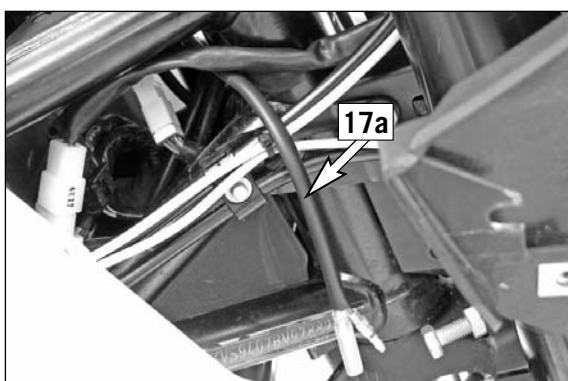

! AVVERTIMENTO

Disporre correttamente tutti i cavi e assicurarli con la fascetta serracavi. Assicurarsi che i cavi non possano venire piegati o bloccati

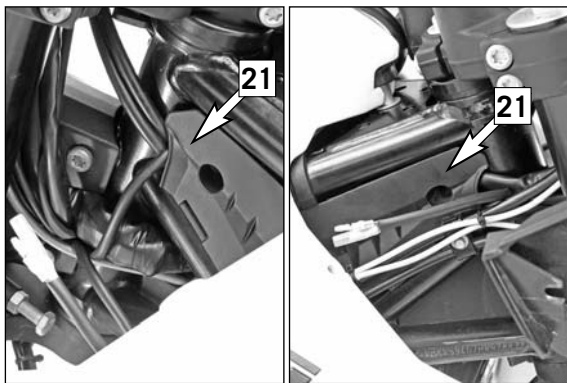

- Rimontare le coperture (20) a sinistra e a destra.

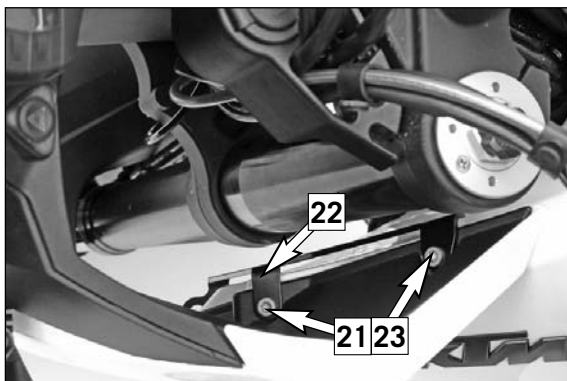

- Applicare le bocche (21) (in dotazione) per i supporti dei fari supplementari di sinistra e destra.

- Posizionare il supporto del faro supplementare di sinistra (22) e montarlo a sinistra con lo spoiler della mascherina e le viti originali (23).

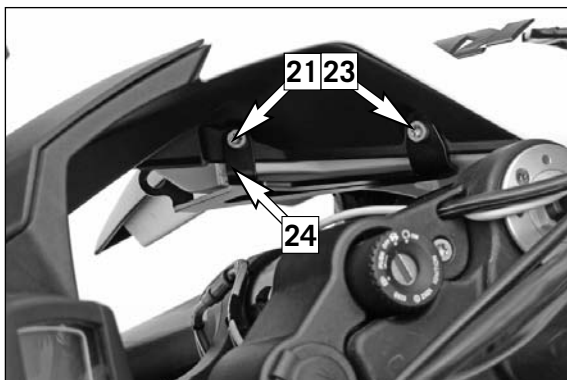

- Posizionare il supporto del faro supplementare di destra (24) e montarlo a destra con lo spoiler della mascherina e le viti originali (23).

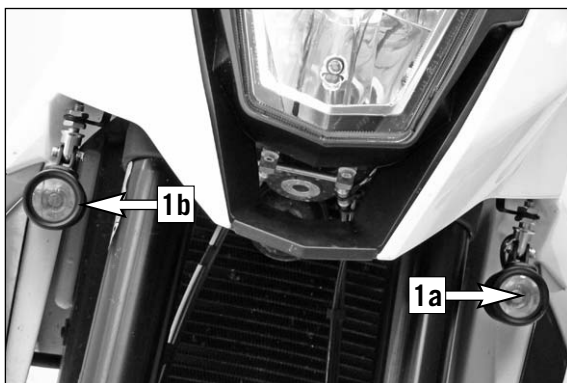

- Montare il faro supplementare di sinistra (1a) e di destra (1b) sui supporti.

NOTA:
Per il montaggio vedi la figura (H)

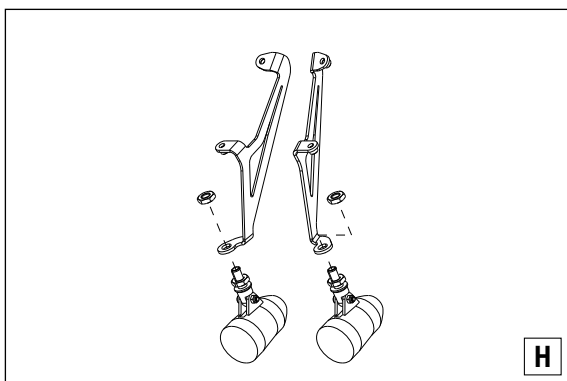

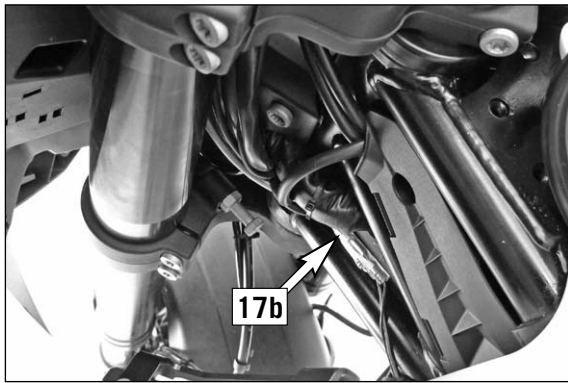

- Disporre i cavi dei fari supplementari a sinistra e a destra e collegarli al cavo (17a) e (17b).

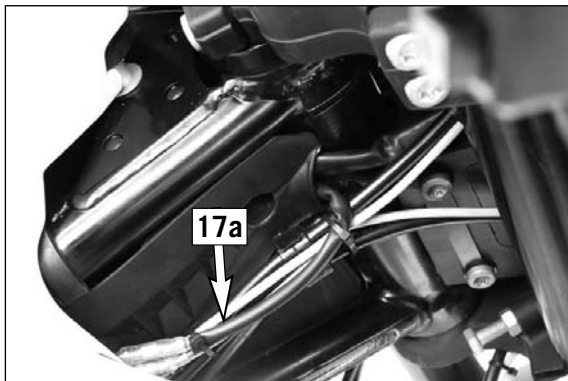

! AVVERTIMENTO

Disporre correttamente tutti i cavi e assicurarli con la fascetta serracavi. Assicurarsi che i cavi non possano venire piegati o bloccati.

⚠ ATTENZIONE

Verificare il funzionamento dell'impianto luci (fari, indicatori di direzione).

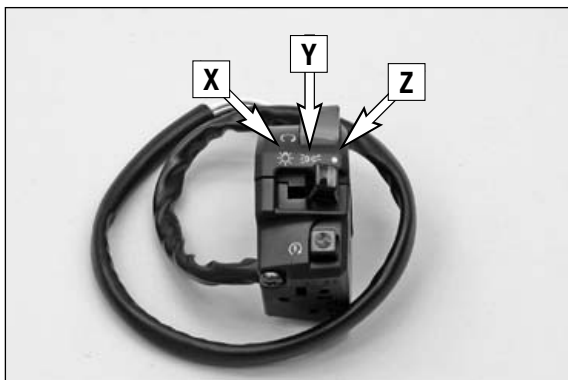

Funzioni dell'interruttore di avviamento, di sicurezza e faro

- Posizione (X) faro supplementare acceso
- Posizione (Y) faro supplementare acceso quando è attiva la luce abbagliante
- Posizione (Z) faro supplementare spento

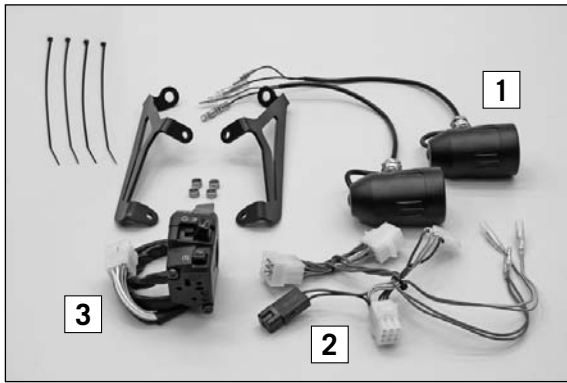

Contenu de la livraison :

- 1x Phare additionnel (1)
- 1x Faisceau de câble d'adaptateur (2)
- 1x Kit de montage
- 1x Module feux / arrêt d'urgence et démarrage (3)

- 60114910000
- 62011910000
- 62014910044
- 60011074000

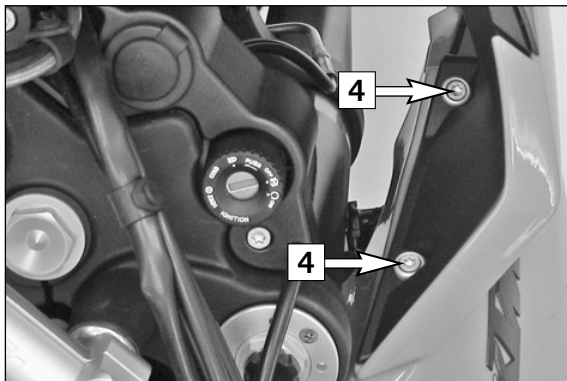

Travaux préalables

- Déposer le déflecteur de plaque-phare.
- Enlever les vis (4) des deux côtés.

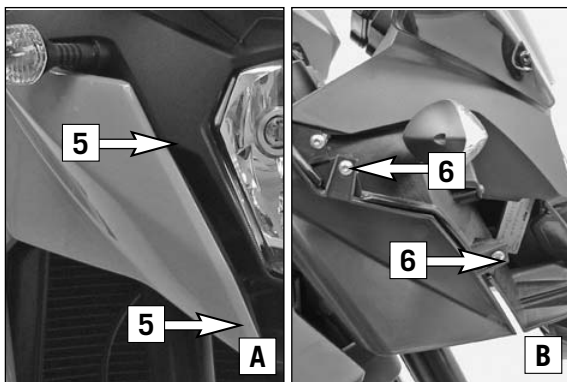

- Enlever les vis (5) des deux côtés (figure A).
- Enlever les vis (6) des deux côtés (figure B).

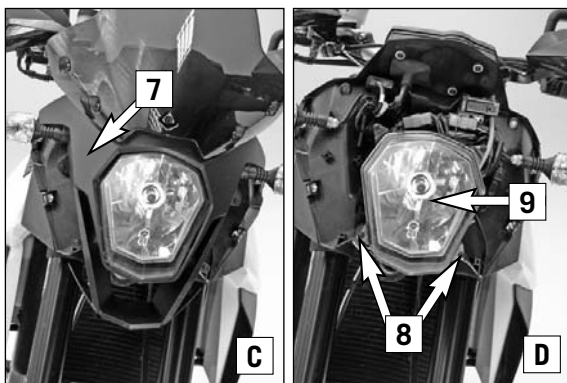

- Enlever toutes les vis de la plaque-phare (7) et déposer la plaque-phare (7) (fig. C).
- Enlever les vis (8) et rabattre le phare (9) avec précaution vers l'avant (fig. D).

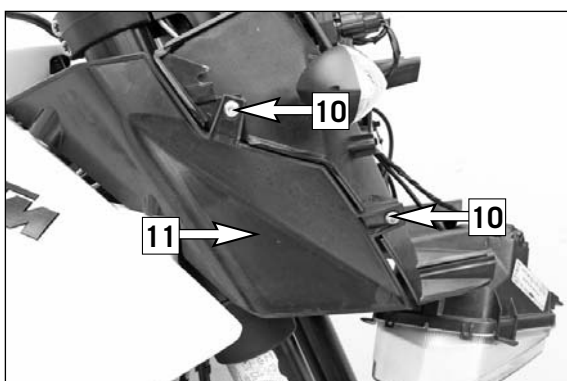

- Enlever les vis (10) des deux côtés et déposer la partie intérieure du déflecteur de plaque-phare (11).

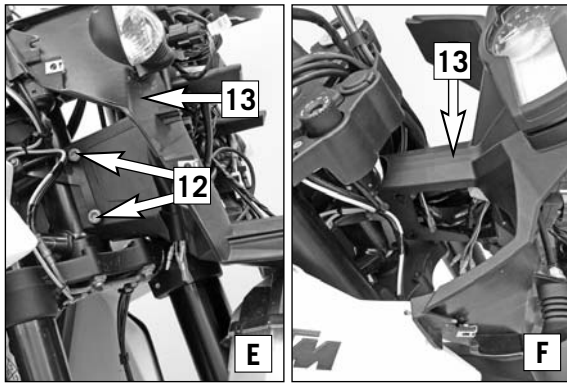

- Enlever les vis (12) des deux côtés (fig.E) et déposer le support de cockpit (13) en le passant par l'avant (fig. F).

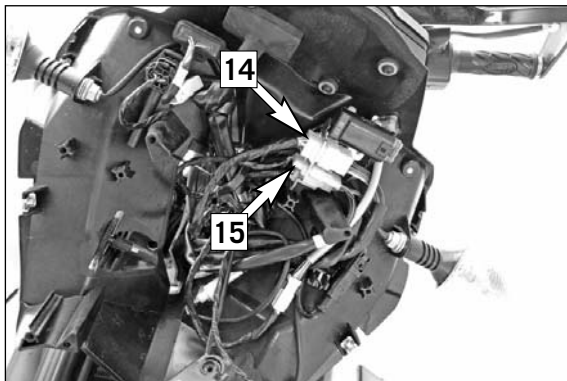

- Débrancher les connecteurs (14) (15).

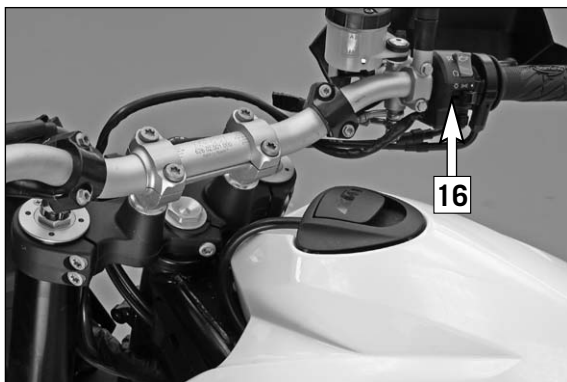

Montage

! ATTENTION

Pour les couples de serrage, consulter le manuel d'utilisation.

- Démontez le module de commande d'origine (16) et montez le module feux / arrêt d'urgence et démarrage (3) (contenu de la livraison).
- Poser le câble du module des feux / arrêt d'urgence et démarrage (3) comme pour le module de commande.

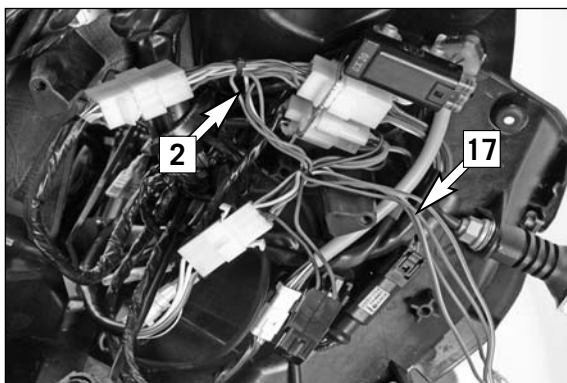

- Brancher le faisceau de câbles de l'adaptateur du phare additionnel (2).
- Brancher tous les connecteurs au faisceau de câble de l'adaptateur du phare additionnel (2).

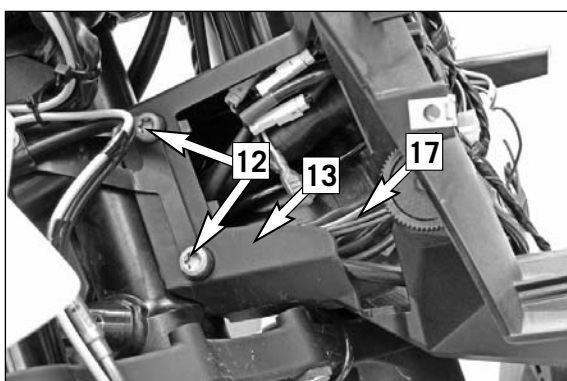

- Mettre en place le support de cockpit (13) et le fixer avec les vis d'origine M8x20 (12).
- Faire passer le branchement des câbles (17) du phare additionnel vers l'arrière.

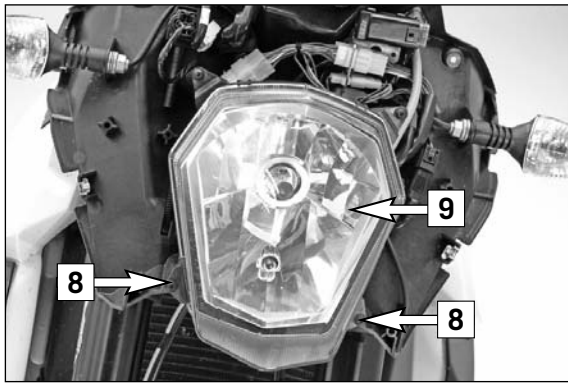

- Mettre en place le phare (9) et le fixer avec les vis d'origine (8).

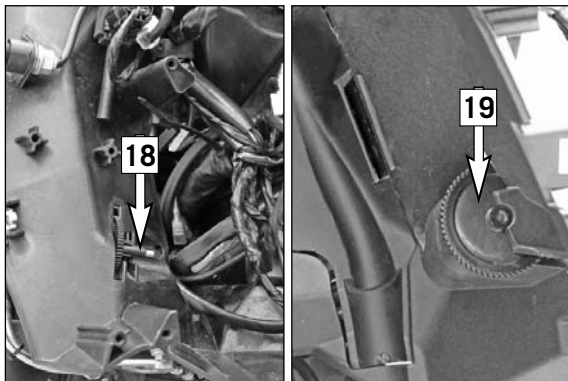

! ATTENTION

Lors du montage du phare, prendre garde à l'axe de guidage (18) du réglage des phares (19).

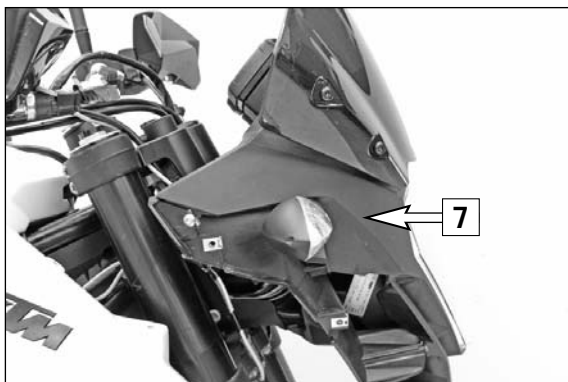

- Monter la plaque-phare (7).

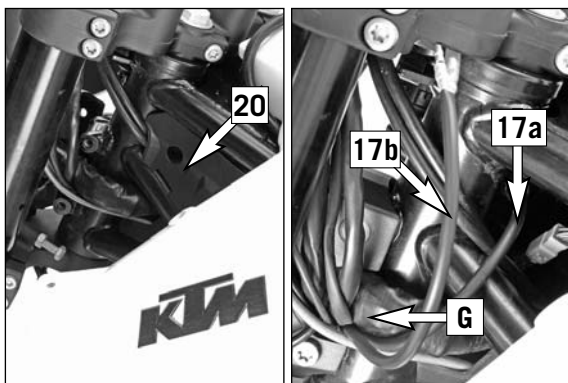

- Déposer le cache (20) des deux côtés.

- Faire passer le câble (17) en position (G) derrière la tête de direction.

- Faire passer le câble (17a) à travers le cadre, vers la droite (branchement pour le phare additionnel de droite).

REMARQUE :

Le câble (17b) reste du côté gauche (branchement pour le phare additionnel de gauche).

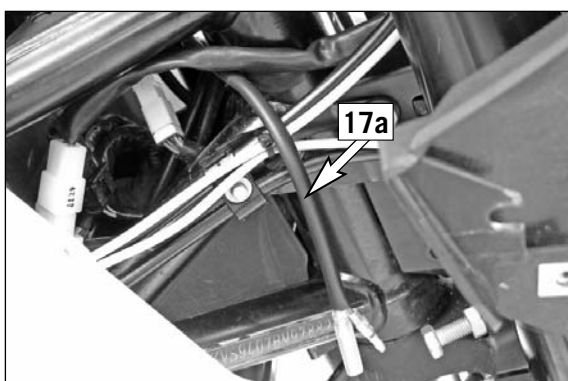

! ATTENTION

Disposer l'ensemble des câbles dans les règles de l'art et les fixer avec des serre-câble.

S'assurer que les câbles ne sont pas pliés ou coincés.

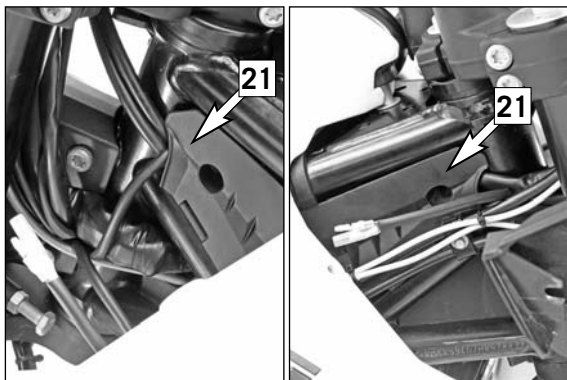

- Remonter les caches **(20)** à gauche et à droite.

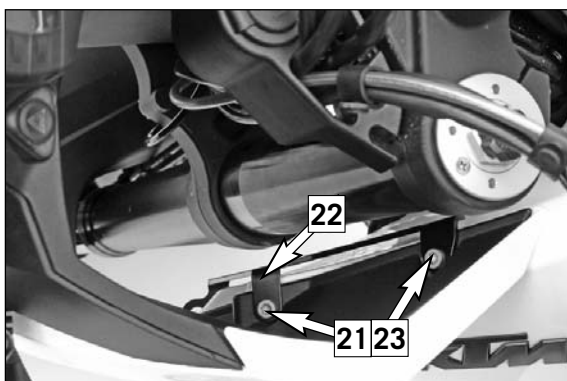

- Placer les bagues **(21)** (contenu de la livraison) du support de phare additionnel, à gauche et à droite.

- Placer le support du phare additionnel de gauche **(22)** et le fixer avec le déflecteur de plaque-phare et les vis d'origine **(23)** à gauche.

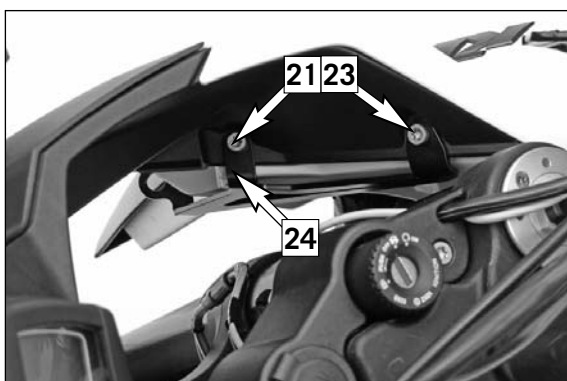

- Placer le support du phare additionnel de droite **(24)** et le fixer avec le déflecteur de plaque-phare et les vis d'origine **(23)** à droite.

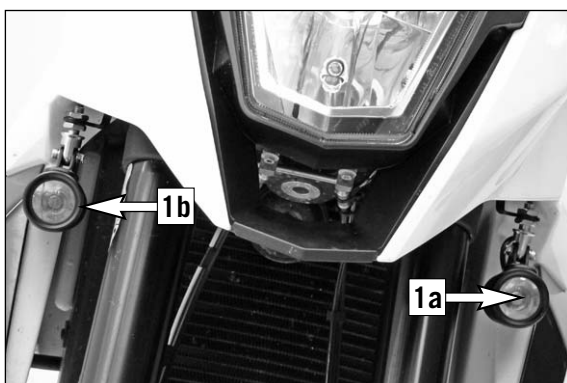

- Monter les phares additionnels de gauche **(1a)** et de droite **(1b)** sur leurs supports.

REMARQUE :
Montage voir la fig. **(H)**

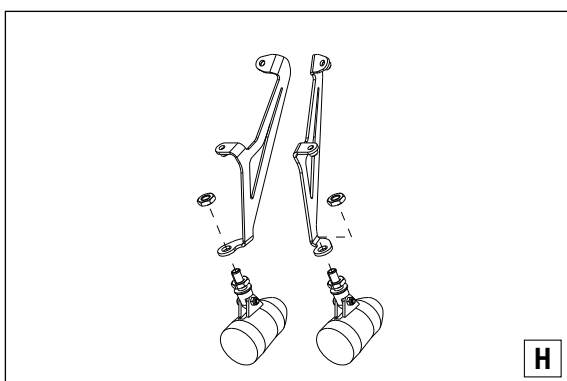

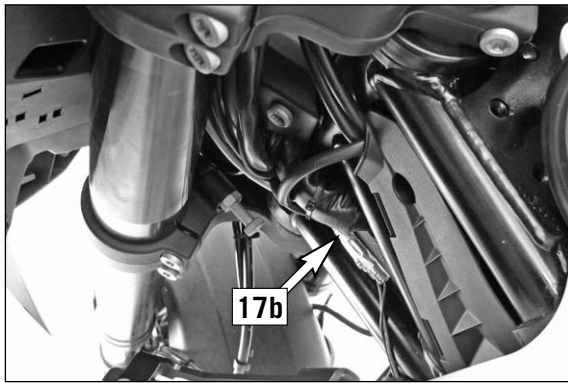

- Poser les câbles des phares additionnels de gauche et de droite et les brancher aux câbles (17a) et (17b).

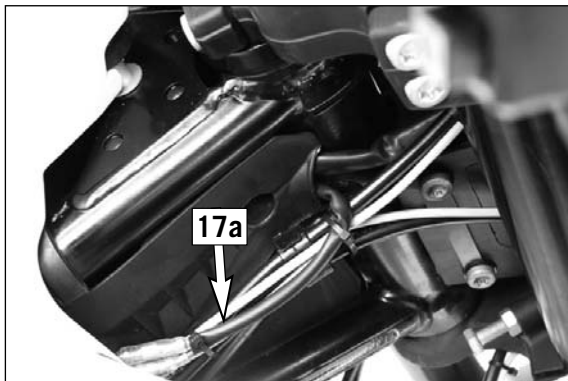

! ATTENTION

Disposer l'ensemble des câbles dans les règles de l'art et les fixer avec des serre-câble.
S'assurer que les câbles ne sont pas pliés ou coincés.

⚠ ATTENTION

Effectuer un test de fonctionnement de l'éclairage (phares, clignotants).

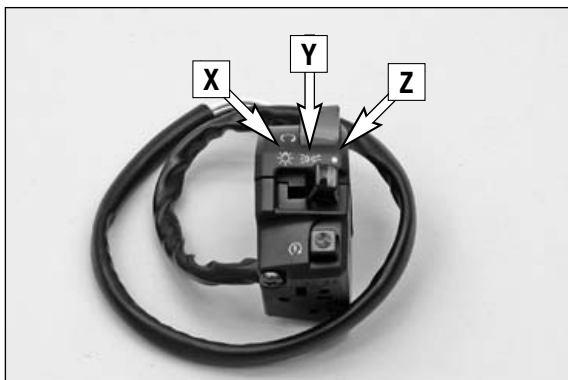

Fonctionnement du module feux / arrêt d'urgence et démarrage

- Position (X) Phare additionnel enclenché
- Position (Y) Phare additionnel enclenché, avec feu de route enclenché également.
- Position (Z) Phare additionnel coupé

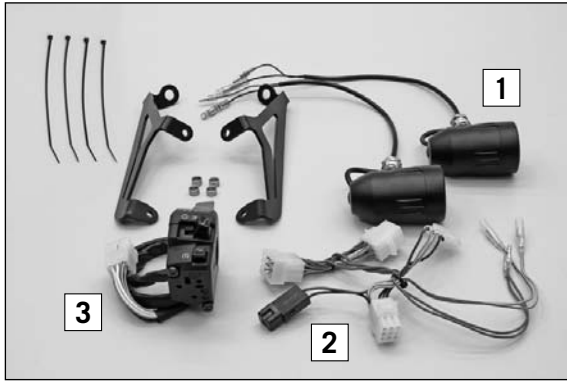

Volumen de suministro:

- | | |
|--|-------------|
| 1x faro adicional (1) | 60114910000 |
| 1x mazo de cables adaptadores para faro adicional (2) | 62011910000 |
| 1x kit de montaje | 62014910044 |
| 1x mando de las luces, de arranque y de parada de emergencia (3) | 60011074000 |

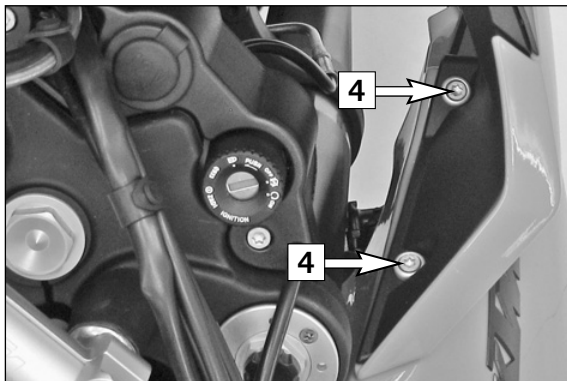

Trabajos previos

- Desmontar el spoiler de la cubierta del faro.
- Retirar los tornillos (4) a ambos lados.

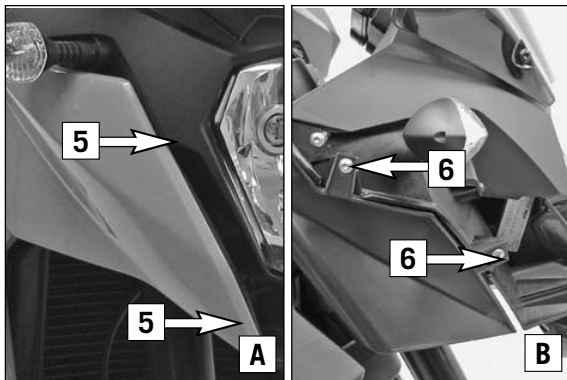

- Retirar los tornillos (5) a ambos lados (figura A).
- Retirar los tornillos (6) a ambos lados (figura B).

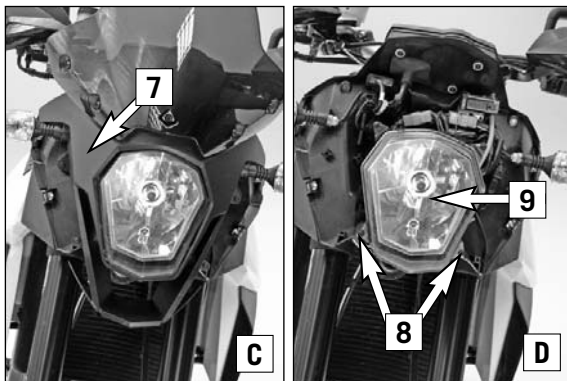

- Retirar todos los tornillos de la cubierta del faro (7) y desmontar la cubierta del faro (7) (figura C).
- Retirar los tornillos (8) y dejar cuidadosamente el faro (9) hacia delante (figura D).

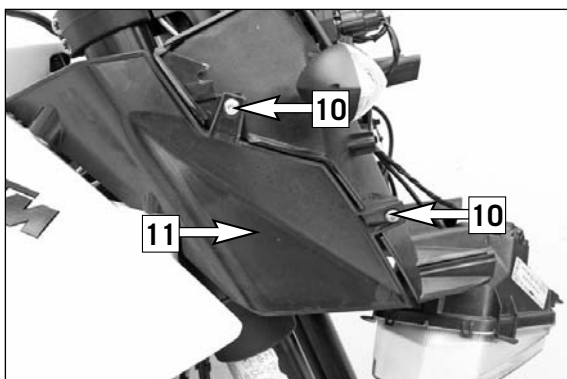

- Extraer los tornillos (10) a ambos lados y retirar la parte interior (11) del spoiler de la cubierta del faro.

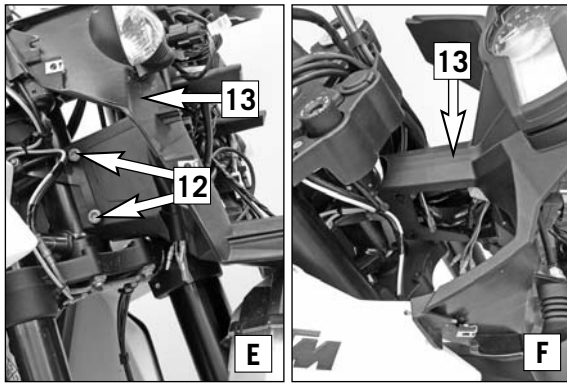

- Extraer los tornillos (12) a ambos lados (figura E) y dejar el soporte del tablero de mandos (13) hacia delante (figura F).

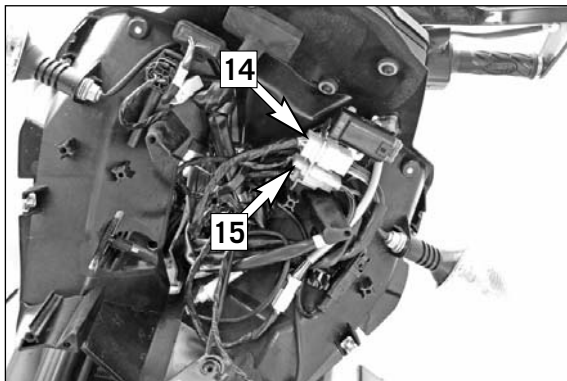

- Desenchufar los conectores (14) y (15).

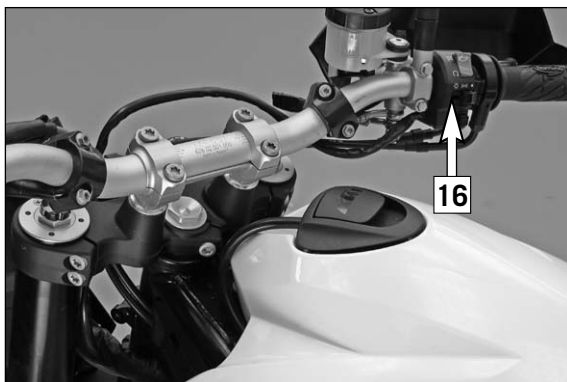

Montaje

! AVISO

Consultar todos los pares de apriete en el manual de instrucciones.

- Desmontar el bloque del mando original (16) y montar el mando de las luces, de arranque y de parada de emergencia (3) (volumen de suministro).
- Tender el cable del mando de las luces, de arranque y de parada de emergencia (3) como el bloque del mando original.

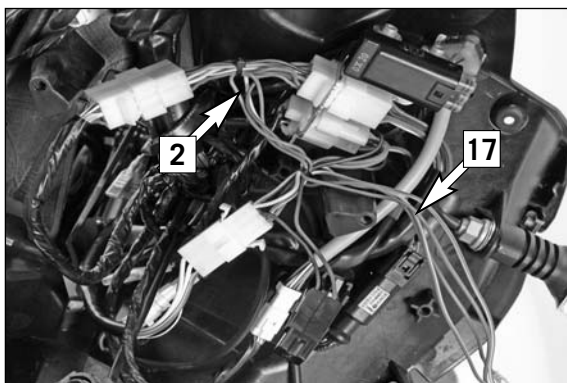

- Conectar el mazo de cables adaptadores del faro adicional (2).
- Conectar todos los conectores al mazo de cables adaptadores del faro adicional (2).

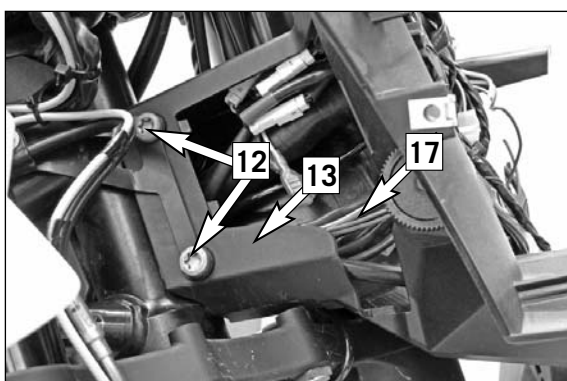

- Posicionar el soporte del tablero de mandos (13) y fijarlo con los tornillos M8x20 originales (12).
- Tender la conexión del cable (17) del faro adicional hacia atrás.

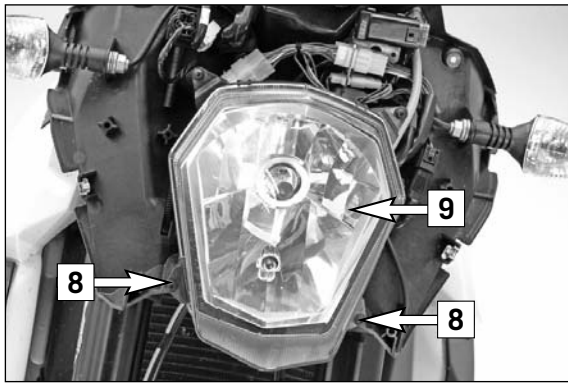

- Posicionar el faro (9) y montarlo con los tornillos originales (8).

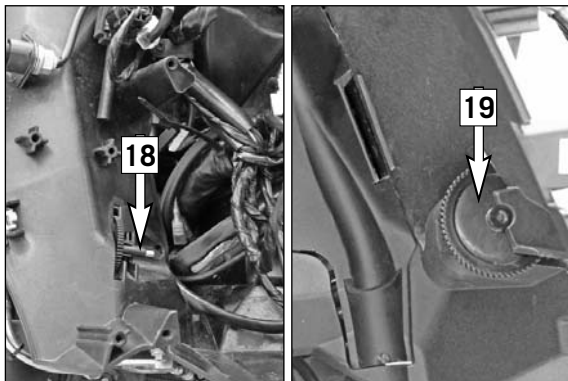

! AVISO

Al montar el faro, prestar atención a la guía (18) de ajuste del faro (19).

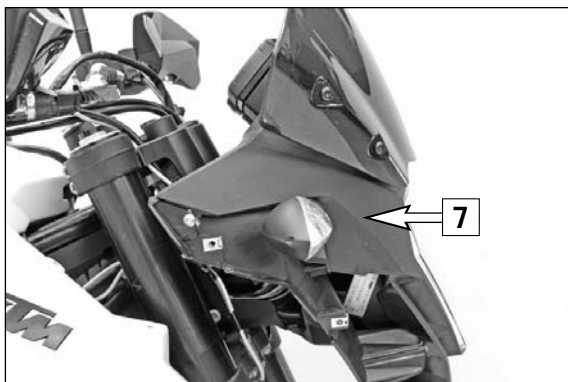

- Montar la cubierta del faro (7).

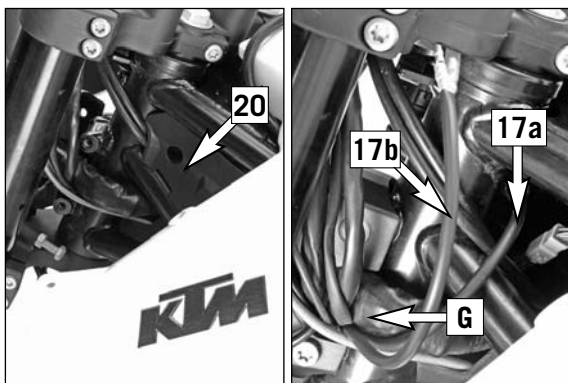

- Desmontar la cubierta (20) en ambos lados.

- Tender el cable (17) por detrás de la pipa de la dirección en la posición (G).

- Tender el cable (17a) hacia la derecha por el chasis (conexión del faro adicional derecho).

ADVERTENCIA:

El cable (17b) permanece en el lado izquierdo (conexión del faro adicional izquierdo).

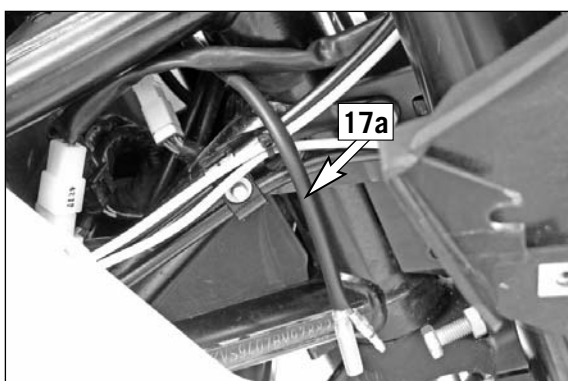

! AVISO

Tender todos los cables de forma correcta y asegurarlos con una abrazadera. Asegurarse de que los cables no puedan retorcerse o quedar aprisionados.

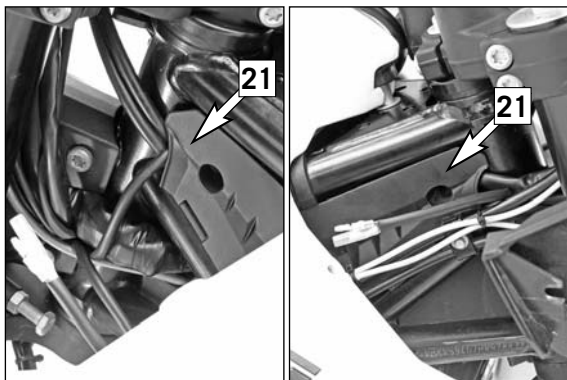

- Volver a montar las cubiertas (20) a la izquierda y a la derecha.

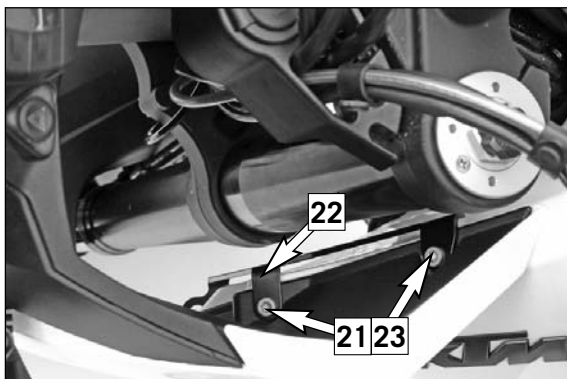

- Colocar los casquillos (21) (volumen de suministro) de los soportes de los faros adicionales izquierdo y derecho.

- Posicionar el soporte del faro adicional izquierdo (22) y montarlo con el spoiler de la cubierta del faro y los tornillos originales (23) del lado izquierdo.

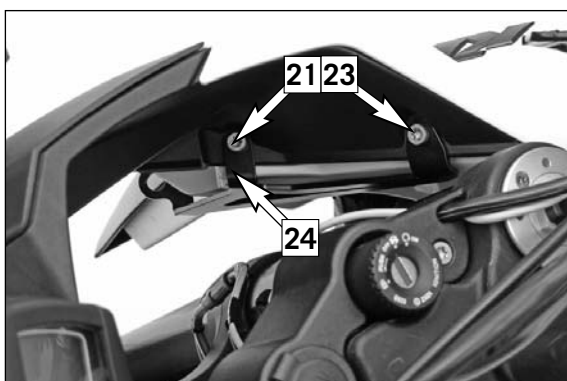

- Posicionar el soporte del faro adicional derecho (24) y montarlo con el spoiler de la cubierta del faro y los tornillos originales (23) del lado derecho.

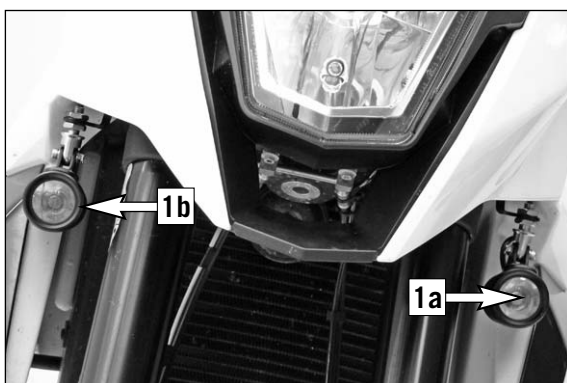

- Montar los faros adicionales izquierdo (1a) y a la derecha (1b) en los soportes.

ADVERTENCIA:
Véase el montaje en la figura (H)

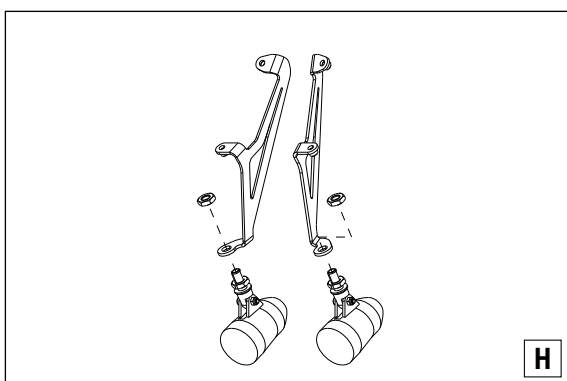

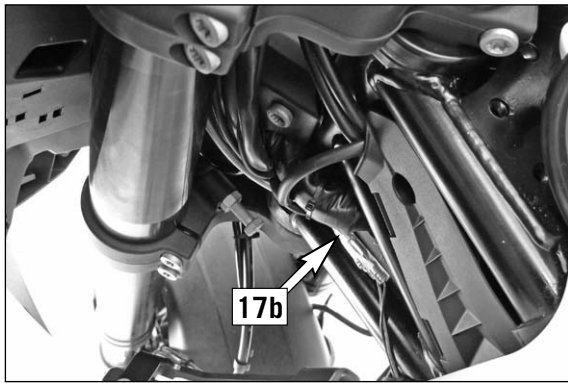

- Tender el cable de los faros adicionales izquierdo y derecho y conectarlo al cable (17a) y (17b).

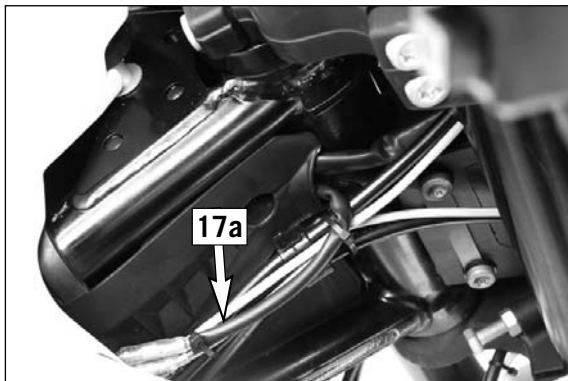

! AVISO

Tender todos los cables de forma correcta y asegurarlos con una abrazadera. Asegurarse de que los cables no puedan retorcerse o quedar aprisionados.

⚠ ATENCION

Realizar una prueba de funcionamiento de las luces (faro, intermitentes).

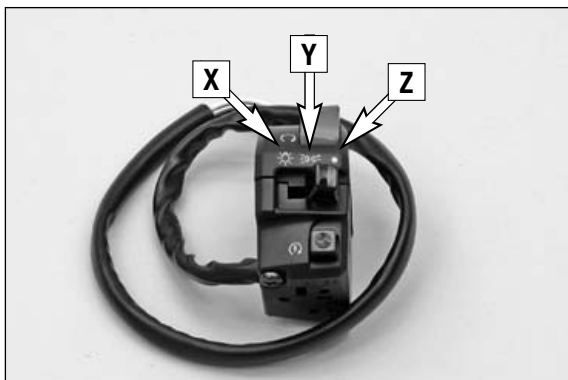

Funcionamiento del mando de las luces, de arranque y de parada de emergencia

- Posición (X) Faro adicional conectado
- Posición (Y) Faro adicional conectado, al conectar la luz de carretera
- Posición (Z) Faro adicional desconectado