

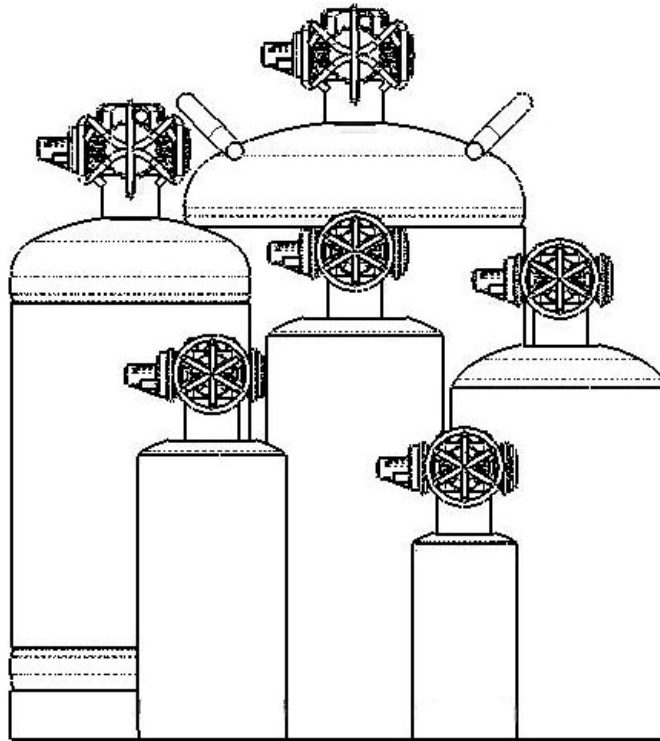

CG2 & MA2 Series
Clean Agent FE-241 & HFC-227ea
Owner's Manual
&
Installation Instructions



For all sizes 25 cubic feet to 1500 cubic feet
Read and comply with all instructions, warnings
and limitations before installing, servicing or
removing this device.

This owner's manual and installation instructions pamphlet is provided in English. Additional copies in English are available at no charge by contacting the manufacturer, distributor or dealer. Copies in the language of destination are available upon request for an additional fee. Fireboy-Xintex reserves the right to change features without notice.

WARNING:

- Do not handle by actuator
- Do not drop
- Keep away from children
- Keep away from extreme heat
- Do not discharge any Fireboy automatic or manual/automatic system unless securely fastened in accordance with the owner's manual
- Never attempt to manually discharge a CG2 Fireboy system
- Never attempt to disassemble any component of this system
- Always wear eye, face and body protection when installing, removing or working in the immediate vicinity of this system

Principle health hazards

- Death without warning if high concentrations are inhaled
- Reduced oxygen available for breathing
- Frostbite from liquid contact
- Increased susceptibility to the toxicity of excess exposure for individuals with pre-existing diseases of the central nervous system, cardiovascular system, lungs or kidneys
- Toxic by-products are produced when this agent extinguishes fire

Medical instructions

- If high concentrations are inhaled, immediately move the exposed to fresh air and keep calm
- If not breathing, give artificial respiration. Seek medical assistance
- If breathing is difficult give oxygen. Seek medical assistance
- In case of skin contact immediately flush skin with water for 15 minutes
- Treat for frostbite if necessary by gently warming affected area. Seek medical assistance if irritation is present
- In case of eye contact, immediately flush eyes with plenty of water for at least 15 minutes. Seek medical assistance
- Wash contaminated clothing before reuse

Fireboy FE-241 Systems contain Chlorotetrafluoroethane.

Chlorotetrafluoroethane has been accepted by the EPA as a suitable alternate to Halon. Fireboy FM Component Approved HFC-227ea Systems contain Heptafluoropropane. Heptafluoropropane has been accepted by the EPA and EU as a suitable alternate to Halon. None of the components in these materials are listed by IARC, NPT, OSHA or ACGIH as a carcinogen.

General Information

Fireboy Automatic (CG series) and Manual/Automatic (MA) series Fire Extinguishing Systems are manufactured for a broad range of applications, including marine, industrial, and commercial uses. This booklet is intended to outline the proper installation of the system for marine applications; most applications are similar. If further technical advice is required, information is available by writing or calling Fireboy-Xintex.

Fireboy FE-241 Systems are approved for use in unoccupied areas, and **are not approved for use within the European Union.**

Fireboy FM Component Approved HFC-227ea Systems are approved for use in occupied areas and are approved for use within the European Union.

MSDS Sheets are available at no charge from the manufacturer and online at www.fireboy-xintex.com.

The National Fire Protection Agency defines normally occupied areas as "one that is intended for occupancy." (NFPA-2001:20049).

WARNING:

Fireboy systems are not, nor are they intended to be, explosion suppression devices. They do not lessen the need to inspect for fire hazards and to ventilate any area where flammable fumes may accumulate.

Referenced Agencies:

Bureau Veritas
3663 N. Sam Houston Pkwy. E., Suite 200
Houston, TX 88034

National Fire Protection Agency
1 Batterymarch Park
Quincy, MA 02269-9101
NFPA 2001, Standard on Clean Agent Fire Extinguishant Systems

FM Approvals
1151 Boston Providence Turnpike
Norwood, MA 02062

United States Coast Guard
2100 Second Street SW
Washington, DC 20593-0001

RINA
10 Upper Belgrave Street
London, SW1X 8BQ

WARNING:

- Never install a Fireboy system on the underside of a hatch cover or on an access door that may open or separate in an explosion
- Never install the actuator of a Fireboy system in close proximity to exhaust manifolds or turbochargers. Radiated heat may cause premature actuation
- Never install the actuator of a Fireboy system below the cylinder (Upside down)
- Never install a Fireboy system where it will trap or be in direct contact with water
- Never install a Fireboy unit in an compartment larger than its volume rating
- Never combine the volume rating of two or more Fireboy units to protect a given compartment
- This device shall not be installed or used in aircraft and/or racing vehicles
- Diesel powered craft must also install the Automatic Engine Shutdown system or this system may not extinguish the fire (See Additional Equipment)

Specifications

When specifications listed on the nameplate label differ from this manual, the information listed on the nameplate label is correct.

CG2 and MA2 series extinguishers discharge automatically at a temperature of 175°F. MA2 series extinguishers discharge manually at any temperature.

Specification Tables and United States Coast Guard Approval Numbers

Model Number	Volume		Diameter		Total Height		Agent Weight		Approximate Shipping Weight		U.S.C.G. #
	Protected ft ³	m ³	in	cm	in	cm	lbs	kgs	lbs	kgs	
CG2-025-FE241	25	0.71	3	8	9.1	23	0.8	0.4	6	2.7	162.029/175/0
CG2-050-FE241	50	1.4	3	8	12.2	31	1.7	0.8	8	3.5	162.029/176/0
CG2-075-FE241	75	2.1	4.3	11	11.9	30	2.5	1.2	9	3.9	162.029/177/0
CG2-100-FE241	100	2.8	4.3	11	14.5	37	3.4	1.5	12	5.6	162.029/178/0
CG2-125-FE241	125	3.5	4.3	11	14.5	37	4.2	1.9	13	6	162.029/179/0
CG2-150-FE241	150	4.3	5.1	13	13.1	33	5.1	2.3	15	6.9	162.029/180/0
CG2-175-FE241	175	4.9	5.1	13	15.5	39	5.9	2.7	16	7.2	162.029/180/0
CG2-200-FE241	200	5.7	5.1	13	15.5	39	6.8	3.1	17	7.6	162.029/181/0
CG2-225-FE241	225	6.4	6.4	16	14.7	37	7.6	3.5	26	11.6	162.029/181/0
CG2-250-FE241	250	7	6.4	16	14.7	37	8.5	3.8	26	12	162.029/182/0
CG2-275-FE241	275	7.8	6.4	16	14.7	37	9.3	4.2	27	12.4	162.029/182/0
CG2-300-FE241	300	8.5	7.2	18	15.1	38	10.1	4.6	32	14.6	162.029/182/0
CG2-325-FE241	325	9.2	7.2	18	15.1	38	11	5	33	15	162.029/183/0
CG2-350-FE241	350	10	7.2	18	15.1	38	11.8	5.4	34	15.4	162.029/183/0
CG2-375-FE241	375	10.6	7.2	18	17.8	45	12.7	5.8	36	16.2	162.029/183/0
CG2-400-FE241	400	11.3	7.2	18	17.8	45	13.5	6.1	37	16.6	162.029/183/0
CG2-450-FE241	450	12.7	7.2	18	17.8	45	15.2	6.9	38	17.4	162.029/184/0
CG2-500-FE241	500	14.1	7.2	18	24.7	63	16.9	7.7	47	21.3	162.029/184/0

Model Number	Volume						Approximate				U.S.C.G. #
	Protected		Diameter		Total Height		Agent Weight		Shipping Weight		
	ft^3	m^3	in	cm	in	cm	lbs	kgs	lbs	kgs	
CG2-550-FE241	550	15.6	7.2	18	24.7	63	18.6	8.5	49	22.1	162.029/185/0
CG2-600-FE241	600	17	7.2	18	24.7	63	20.3	9.2	50	22.9	162.029/185/0
CG2-650-FE241	650	18.4	7.2	18	24.7	63	22	10	52	23.6	162.029/185/0
CG2-700-FE241	700	19.8	10	25	21.6	55	23.7	10.8	64	28.9	162.029/185/0
CG2-750-FE241	750	21.2	10	25	21.6	55	25.4	11.5	65	29.7	162.029/185/0
CG2-800-FE241	800	22.6	10	25	21.6	55	27	12.3	67	30.5	162.029/186/0
CG2-850-FE241	850	24	10	25	21.6	55	28.7	13.1	69	31.2	162.029/186/0
CG2-900-FE241	900	25.5	10	25	21.6	55	30.4	13.8	70	32	162.029/186/0
CG2-950-FE241	950	26.9	10	25	21.6	55	32.1	14.6	72	32.8	162.029/186/0
CG2-1000-FE241	1000	28.3	10	25	21.6	55	33.8	15.4	74	33.5	162.029/186/0
MA2-025-FE241	25	0.71	3	8	9.1	23	0.8	0.4	6	2.7	162.029/187/0
MA2-050-FE241	50	1.4	3	8	12.2	31	1.7	0.8	8	3.5	162.029/188/0
MA2-075-FE241	75	2.1	4.3	11	11.9	30	2.5	1.2	9	3.9	162.029/189/0
MA2-100-FE241	100	2.8	4.3	11	14.5	37	3.4	1.5	12	5.6	162.029/190/0
MA2-125-FE241	125	3.5	4.3	11	14.5	37	4.2	1.9	13	6	162.029/191/0
MA2-150-FE241	150	4.3	5.1	13	13.1	33	5.1	2.3	15	6.9	162.029/192/0
MA2-175-FE241	175	4.9	5.1	13	15.5	39	5.9	2.7	16	7.2	162.029/192/0
MA2-200-FE241	200	5.7	5.1	13	15.5	39	6.8	3.1	17	7.6	162.029/193/0
MA2-225-FE241	225	6.4	6.4	16	14.7	37	7.6	3.5	26	11.6	162.029/193/0
MA2-250-FE241	250	7	6.4	16	14.7	37	8.5	3.8	26	12	162.029/194/0
MA2-275-FE241	275	7.8	6.4	16	14.7	37	9.3	4.2	27	12.4	162.029/194/0
MA2-300-FE241	300	8.5	7.2	18	15.1	38	10.1	4.6	32	14.6	162.029/194/0
MA2-325-FE241	325	9.2	7.2	18	15.1	38	11	5	33	15	162.029/195/0
MA2-350-FE241	350	10	7.2	18	15.1	38	11.8	5.4	34	15.4	162.029/195/0
MA2-375-FE241	375	10.6	7.2	18	17.8	45	12.7	5.8	36	16.2	162.029/195/0
MA2-400-FE241	400	11.3	7.2	18	17.8	45	13.5	6.1	37	16.6	162.029/195/0
MA2-450-FE241	450	12.7	7.2	18	17.8	45	15.2	6.9	38	17.4	162.029/196/0
MA2-500-FE241	500	14.1	7.2	18	24.7	63	16.9	7.7	47	21.3	162.029/196/0
MA2-550-FE241	550	15.6	7.2	18	24.7	63	18.6	8.5	49	22.1	162.029/197/0
MA2-600-FE241	600	17	7.2	18	24.7	63	20.3	9.2	50	22.9	162.029/197/0
MA2-650-FE241	650	18.4	7.2	18	24.7	63	22	10	52	23.6	162.029/197/0
MA2-700-FE241	700	19.8	10	25	21.6	55	23.7	10.8	64	28.9	162.029/197/0
MA2-750-FE241	750	21.2	10	25	21.6	55	25.4	11.5	65	29.7	162.029/197/0
MA2-800-FE241	800	22.6	10	25	21.6	55	27	12.3	67	30.5	162.029/198/0
MA2-850-FE241	850	24	10	25	21.6	55	28.7	13.1	69	31.2	162.029/198/0
MA2-900-FE241	900	25.5	10	25	21.6	55	30.4	13.8	70	32	162.029/198/0
MA2-950-FE241	950	26.9	10	25	21.6	55	32.1	14.6	72	32.8	162.029/198/0
MA2-1000-FE241	1000	28.3	10	25	21.6	55	33.8	15.4	74	33.5	162.029/198/0
MA2-1050-FE241	1050	29.7	10	25	21.6	55	35.5	16.1	75	34.3	162.029/199/0
MA2-1100-FE241	1100	31.1	10	25	21.6	55	37.2	16.9	77	35.1	162.029/200/0
MA2-1150-FE241	1150	33	10	25	21.6	55	38.9	17.7	79	35.9	162.029/200/0
MA2-1200-FE241	1200	34	10	25	27.7	70	40.6	18.4	86	38.9	162.029/200/0
MA2-1250-FE241	1250	35.4	10	25	27.7	70	42.3	19.2	87	39.7	162.029/200/0
MA2-1300-FE241	1300	36.8	10	25	27.7	70	60.8	27.7	106	48.1	162.029/201/0
MA2-1350-FE241	1350	38.2	10	25	27.7	70	63.2	28.7	108	49.2	162.029/201/0
MA2-1400-FE241	1400	39.6	10	25	27.7	70	65.5	29.8	111	50.2	162.029/201/0
MA2-1450-FE241	1450	41	10	25	27.7	70	67.9	30.8	113	51.3	162.029/201/0
MA2-1500-FE241	1500	42.5	10	25	27.7	70	70.2	31.9	115	52.4	162.029/201/0
CG2-025-227	25	0.71	3	8	9.1	23	1.1	0.5	6	2.8	162.029/202/0
CG2-050-227	50	1.4	3	8	12.2	31	2.2	1	8	3.7	162.029/203/0
CG2-075-227	75	2.1	4.3	11	11.9	30	3.2	1.5	9	4.2	162.029/205/0
CG2-100-227	100	2.8	4.3	11	14.5	37	4.3	2	13	6.1	162.029/205/0
CG2-125-227	125	3.5	4.3	11	14.5	37	5.4	2.5	14	6.5	162.029/206/0
CG2-150-227	150	4.3	5.1	13	13.1	33	6.5	2.9	16	7.5	162.029/207/0
CG2-175-227	175	4.9	5.1	13	15.5	39	7.6	3.4	18	8	162.029/208/0
CG2-200-227	200	5.7	5.1	13	15.5	39	8.6	3.9	19	8.5	162.029/208/0
CG2-225-227	225	6.4	6.4	16	14.7	37	9.7	4.4	28	12.6	162.029/209/0
CG2-250-227	250	7	6.4	16	14.7	37	10.8	4.9	29	13.1	162.029/209/0
CG2-275-227	275	7.8	6.4	16	14.7	37	11.9	5.4	30	13.6	162.029/209/0

Model Number	Volume				Agent Weight				Approximate		U.S.C.G. #
	Protected		Diameter		Total Height		Shipping Weight				
	ft^3	m^3	in	cm	in	cm	lbs	kgs	lbs	kgs	
CG2-300-227	300	8.5	7.2	18	15.1	38	13	5.9	35	15.9	162.029/210/0
CG2-325-227	325	9.2	7.2	18	15.1	38	14	6.4	36	16.4	162.029/210/0
CG2-350-227	350	10	7.2	18	15.1	38	15.1	6.9	37	16.9	162.029/210/0
CG2-375-227	375	10.6	7	18	18.8	48	16.2	7.4	38	17.4	162.029/210/0
CG2-400-227	400	11.3	7	18	18.8	48	17.3	7.9	39	17.9	162.029/211/0
CG2-450-227	450	12.7	7	18	18.8	48	19.4	8.8	41	18.8	162.029/211/0
CG2-500-227	500	14.1	7	18	25.7	65	21.6	9.8	47	21.2	162.029/212/0
CG2-550-227	550	15.6	7	18	25.7	65	23.8	10.8	49	22.2	162.029/212/0
CG2-600-227	600	17	7	18	25.7	65	25.9	11.8	51	23.1	162.029/212/0
CG2-650-227	650	18.4	7	18	25.7	65	28.1	12.8	53	24.1	162.029/213/0
CG2-700-227	700	19.8	10	25	21.6	55	30.2	13.7	77	35.1	162.029/213/0
CG2-750-227	750	21.2	10	25	21.6	55	32.4	14.7	79	36.1	162.029/213/0
CG2-800-227	800	22.6	10	25	21.6	55	34.6	15.7	82	37.1	162.029/213/0
CG2-850-227	850	24	10	25	21.6	55	36.7	16.7	84	38.1	162.029/213/0
CG2-900-227	900	25.5	10	25	21.6	55	38.9	17.7	86	39	162.029/214/0
CG2-950-227	950	26.9	10	25	21.6	55	41	18.7	88	40	162.029/214/0
CG2-1000-227	1000	28.3	10	25	21.6	55	43.2	19.6	90	41	162.029/214/0
MA2-025-227	25	0.71	3	8	9.1	23	1.1	0.5	6	2.8	162.029/215/0
MA2-050-227	50	1.4	3	8	12.2	31	2.2	1	8	3.7	162.029/216/0
MA2-075-227	75	2.1	4.3	11	11.9	30	3.2	1.5	9	4.2	162.029/218/0
MA2-100-227	100	2.8	4.3	11	14.5	37	4.3	2	13	6.1	162.029/218/0
MA2-125-227	125	3.5	4.3	11	14.5	37	5.4	2.5	14	6.5	162.029/219/0
MA2-150-227	150	4.3	5.1	13	13.1	33	6.5	2.9	16	7.5	162.029/220/0
MA2-175-227	175	4.9	5.1	13	15.5	39	7.6	3.4	18	8	162.029/221/0
MA2-200-227	200	5.7	5.1	13	15.5	39	8.6	3.9	19	8.5	162.029/221/0
MA2-225-227	225	6.4	6.4	16	14.7	37	9.7	4.4	28	12.6	162.029/222/0
MA2-250-227	250	7	6.4	16	14.7	37	10.8	4.9	29	13.1	162.029/222/0
MA2-275-227	275	7.8	6.4	16	14.7	37	11.9	5.4	30	13.6	162.029/222/0
MA2-300-227	300	8.5	7.2	18	15.1	38	13	5.9	35	15.9	162.029/223/0
MA2-325-227	325	9.2	7.2	18	15.1	38	14	6.4	36	16.4	162.029/223/0
MA2-350-227	350	10	7.2	18	15.1	38	15.1	6.9	37	16.9	162.029/223/0
MA2-375-227	375	10.6	7	18	18.8	48	16.2	7.4	38	17.4	162.029/223/0
MA2-400-227	400	11.3	7	18	18.8	48	17.3	7.9	39	17.9	162.029/224/0
MA2-450-227	450	12.7	7	18	18.8	48	19.4	8.8	41	18.8	162.029/224/0
MA2-500-227	500	14.1	7	18	25.7	65	21.6	9.8	47	21.2	162.029/225/0
MA2-550-227	550	15.6	7	18	25.7	65	23.8	10.8	49	22.2	162.029/225/0
MA2-600-227	600	17	7	18	25.7	65	25.9	11.8	51	23.1	162.029/225/0
MA2-650-227	650	18.4	7	18	25.7	65	28.1	12.8	53	24.1	162.029/226/0
MA2-700-227	700	19.8	10	25	21.6	55	30.2	13.7	77	35.1	162.029/226/0
MA2-750-227	750	21.2	10	25	21.6	55	32.4	14.7	79	36.1	162.029/226/0
MA2-800-227	800	22.6	10	25	21.6	55	34.6	15.7	82	37.1	162.029/226/0
MA2-850-227	850	24	10	25	21.6	55	36.7	16.7	84	38.1	162.029/226/0
MA2-900-227	900	25.5	10	25	21.6	55	38.9	17.7	86	39	162.029/227/0
MA2-950-227	950	26.9	10	25	21.6	55	41	18.7	88	40	162.029/227/0
MA2-1000-227	1000	28.3	10	25	21.6	55	43.2	19.6	90	41	162.029/227/0
MA2-1050-227	1050	29.7	10	25	21.6	55	45.4	20.6	92	42	162.029/228/0
MA2-1100-227	1100	31.1	10	25	21.6	55	47.5	21.6	95	43	162.029/229/0
MA2-1150-227	1150	33	10	25	21.6	55	49.7	22.6	97	43.9	162.029/229/0
MA2-1200-227	1200	34	10	25	27.7	70	51.8	23.6	105	47.7	162.029/229/0
MA2-1250-227	1250	35.4	10	25	27.7	70	54	24.5	107	48.6	162.029/229/0
MA2-1300-227	1300	36.8	10	25	27.7	70	56.2	25.5	109	49.6	162.029/229/0
MA2-1350-227	1350	38.2	10	25	27.7	70	58.3	26.5	111	50.6	162.029/229/0
MA2-1400-227	1400	39.6	10	25	27.7	70	60.5	27.5	113	51.6	162.029/230/0
MA2-1450-227	1450	41	10	25	27.7	70	62.6	28.5	116	52.6	162.029/230/0
MA2-1500-227	1500	42.5	10	25	27.7	70	64.8	29.5	118	53.5	162.029/230/0

Marine Installation Instructions

Before Installation

1. Check the system for damage during shipment.
2. Check the pressure gauge to be sure the gauge pointer lies within the green zone at 70°F (21°C). The correct weight is shown on the nameplate for the appropriate model.
3. Select an interior location not directly subject to weather or seawater.
4. Confirm the volume of the compartment to be protected in cubic feet or cubic meters by multiplying the width in feet, by the length in feet, by the depth at the keel in feet; make no deductions for installed equipment.
5. Verify calculated volume with volume shown on name plate label and chart on opposite page.

Selecting a Location

1. Do not install a Fireboy system rated for less cubic volume than the volume of the compartment to be protected.
2. Orientation:
 - Mounting up to 90° from vertical is permissible
 - Install on the forward or aft vertical bulkhead of the engine compartment as near the centerline of the vessel (keel) as possible.
 - Install as high as possible
 - Direct the actuator towards the opposite bulkhead or towards the engine(s)
 - Avoid installing athwart ship (perpendicular to the keel) on sailboats

Mounting Fireboy system

1. Locate the lower bracket 1 ½" above the bottom of the cylinder and the upper bracket ½" above the Fireboy nameplate. If required the 3rd bracket needs to be centered between the upper and lower brackets.
2. Use appropriate size and length stainless steel bolts and lock washers and bolt to bulk head or overhead.

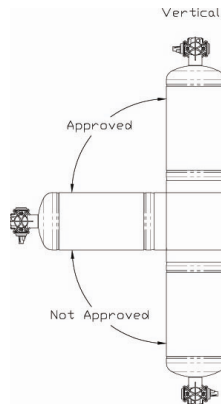

Accommodating Diesel Engines

1. **Failure to install an Automatic Engine Shutdown in any compartment containing a diesel engine and a Fireboy system impedes the fire extinguisher and may prevent fire extinguishment.**
2. Automatic Engine Shutdown units are available through your Fireboy-Xintex distributor, dealer or retailer in three, five and eight circuit models.
3. Follow the installation instructions included with the Automatic Engine Shutdown for proper installation.
4. Technical Support for Automatic Engine Shutdowns is available by calling Fireboy-Xintex or visiting our website at www.fireboy-xintex.com.

Installing Indicator Lamp

Mounting Lamp

1. U.S. Coast Guard regulations require an indicator lamp and escutcheon plate at each helm position from which the craft may be operated.
2. Your Fireboy System is supplied with one (1) indicator lamp and escutcheon plate. Additional indicator lamps and escutcheon plates are available factory direct, or through an authorized dealer (see Additional Equipment).
3. Select an appropriate location for the indicator lamp and escutcheon plate on or near the instrument panel at the helm and in full view of the operator.
4. Drill a 5/16" hole.
5. Remove the backing paper on the escutcheon panel.
6. Feed both wires through 5/16" hole.
7. Press escutcheon plate firmly press in place.

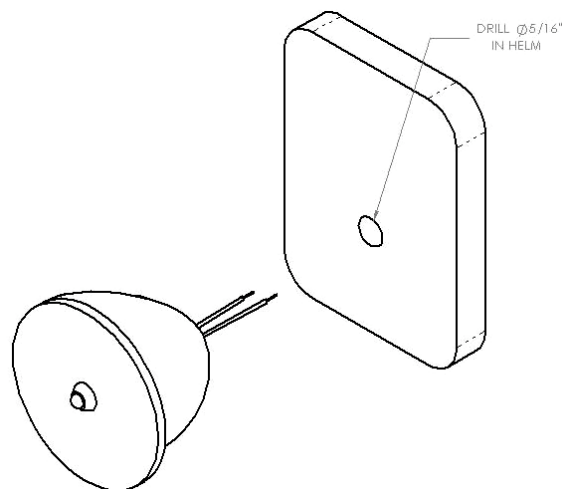

WARNING:

- An electrical short may result in electrical burn, injury or fire
- Before attempting to wire the indicator lamp, turn off all electrical current to the ignition switch
- All Fireboy wiring must comply with the American Boat and Yacht Council Standard E9-9, titled Direct Current Electrical Systems for Boats, available from ABYC, 3069 Solomon's Island Road, Edgewater, MD 21037
- The indicator lamp supplied is for 12 VDC use only

Wiring Instructions

1. Review all wiring instructions below.
2. Consult a qualified marine electrician if you have any doubts about your ability to safely and properly complete the wiring. Ignition systems and electrical systems vary from boat to boat, and the directions which follow, may not apply to your boat.
3. Assemble the supplies you will need that are not included with your Fireboy System.
 - The necessary length of insulated 16 gauge (minimum) stranded wire
 - A one-half (.5) ampere in-line fuse and fuse holder or circuit breaker
 - Properly sized insulated crimp-on wire connectors
4. Connect one lead of the fuse to the "ignition" position of the starter switch.
5. Connect the other lead of the fuse to the red (+) wire of the LED indicator lamp.
6. Connect the black (-) wire of the indicator lamp to one of the pigtail wires on the Fireboy System (as shown below).
7. Do not reverse red and black wire, system will not function.
8. Connect the remaining wire from the Fireboy system to ground.

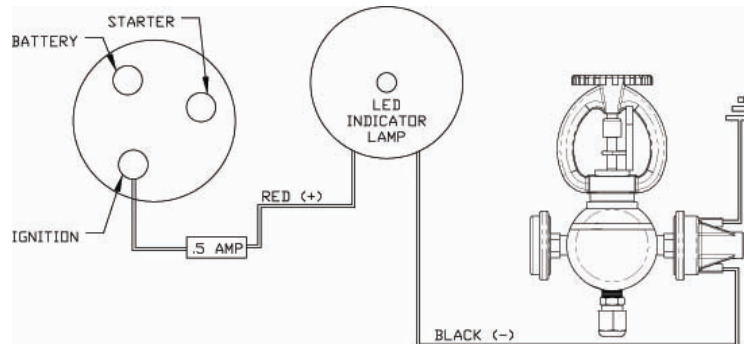

Engine compartments not equipped with a powered ventilation system require no further wiring.

If the engine compartment is equipped with a powered ventilation system, U.S. Coast Guard Rule 162.029 requires that the ground connection of the ventilation system be connected to the Fireboy system. **Failure to connect a powered ventilation system in the manner described below impedes fire extinguisher and may prevent fire extinguishment.**

Powered Ventilation Systems (Blowers)

1. Determine the maximum current draw of the powered ventilation system.
2. For current draw not exceeding 5 amps either:
 - Connect the negative (-) wire of the ventilation blower to the pressure switch at the same point as the indicator lamp, or
 - Connect the negative (-) wire of the ventilation blower to the number 1 terminal of a Fireboy Automatic Engine Shutdown system if available (recommended)
3. For current draw exceeding 5 amps connect the negative (-) wire of the powered ventilation system to the number (1) terminal of a Fireboy Automatic Engine Shutdown system.

NOTE:

The Escutcheon plate LED is connected to the pressure switch at the same point that auxiliary devices can be connected. Care must be taken when wiring other devices to the pressure switch to ensure the presence of the LED does not affect the operation of the device. Contact Fireboy-Xintex technical support regarding any installation questions.

Use of indicator lamp

- The Fireboy System indicator lamp is designed to announce to the helmsman the state of the fire extinguisher when the ignition key is in the ON position.
- A GLOWING green light indicates the Fireboy system is CHARGED.
- A NON GLOWING light indicates the Fireboy system is DISCHARGED.

Cable Installation

WARNING:

1. All Fireboy MA Systems installations must use only genuine Fireboy cables and associated components that are engineered specifically for this application.
2. Nothing else will provide the intended degree of safety and reliability inherent in these systems.
3. Any substitution will void all laboratory and Coast Guard approvals and Fireboy-Xintex warranties, and may result in an inoperative system, and unsafe and hazardous conditions.
4. Never install a manual release handle in the space to be protected.
5. Never install a cable on a CG2 Series. For use on MA2 Series only.

NOTE:

Never push the cable at the T-handle end. Cable may jam and become inoperable.

Fixing a jammed cable:

1. Turn the T-handle and threaded metal rod counter clockwise $\frac{1}{2}$ turn until the jam releases.
2. If necessary, use a pair of pliers to carefully twist the threaded metal rod until the jam releases.
3. Pull the cable from the "S" hook until the cable returns to an operational position.
4. **Do not connect cable to cylinder at this time.**

Routing the cable:

1. Locate the escutcheon plate (2 $\frac{1}{2}$ " x 4" with 13/32 hole) for the manual release handle.
 - At the helm station
 - On a firm support
 - In full view of the operator
 - With enough clearance for the cable ferrule to extend approximately 12 inches behind the panel
2. Using the escutcheon plate as a template, locate and drill a 13/32" hole.
3. Route the cable in the most direct manner, with as few bends as possible, to the cylinder location.
 - Do not bend in a radius of less than 6 inches (a 12 inch circle)
 - Follow the same route as manufacturer installed cables, if possible (Example: Steering, throttle, and transmission cables)
 - Do not subject cable to pinching or crushing, rubbing, extreme vibration, sharp bending or kinking, or extremes of heat or cold
 - Do not exceed 360° of bends (Example: Four 90° bends = 4 x 90° = 360°)
 - Use the shortest allowable cable whenever possible
 - If excess cable must be coiled; do not coil excess cable in the protected enclosure
4. Secure loose sections of the cable with the included nylon clamps.
 - Do not clamp cable in a bend
 - Do not crush cable with clamps

Escutcheon Panel and T-Handle

1. Ensure temperature is above +50°F (10°C) for proper adhesion.
2. Peel the release paper from the back of the escutcheon plate.
3. Align the larger hole with the 13/32 hole drilled in dash.
4. Press escutcheon plate down evenly to activate adhesive.
5. Following figure below, place nut and lock washer in place on the cable end and insert through the 13/32" hole in the panel and escutcheon.

6. Pull cable to full extension.
7. Screw ferrule on to cable (approximately 4-5 turns maximum).
8. Slide o-ring onto cable shaft.
9. Screw red T-handle onto cable shaft (Do not obstruct cross hole in T-handle).
10. Push red T-handle into ferrule to seat o-ring.
11. Align holes in ferrule and T-handle.
12. Temporarily install pull pin.
13. Align T-handle so the word "FIRE" is vertical.
14. Tighten the nut behind the panel.
15. Recheck cable installation.
16. CABLE MUST NOT BE CONNECTED TO CYLINDER AT THIS TIME.
17. Remove pull pin.
18. Pass the red tamper proof seal through the ring of the pull pin and around the ferrule.
19. Insert the free end of the seal into the projecting portion of the tab end (marked "enter").
20. Pull seal snug to secure the pull pin from accidental release.

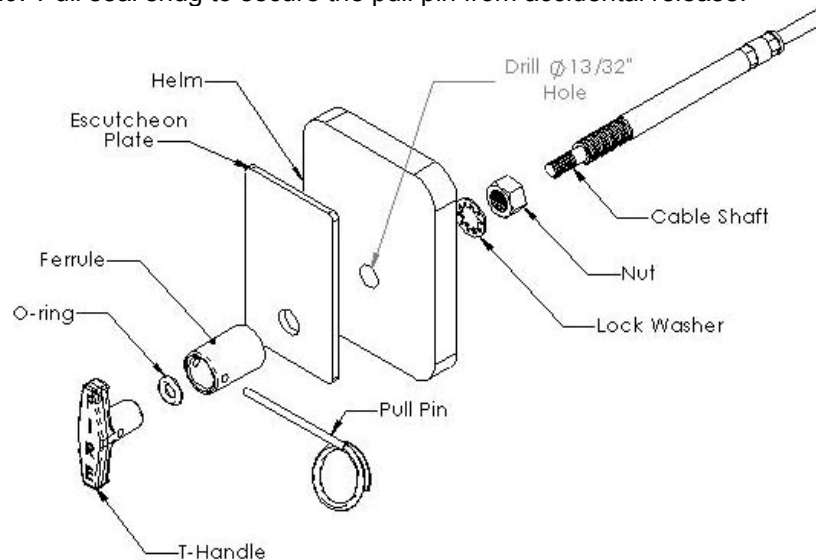

Dual Release Adapter:

- If the vessel has more than one helm, a Dual Release Adapter , DRA-1001-01 is required (see Additional Equipment)
- Follow the instructions enclosed with the dual release adapter

Connecting cable to cylinder – See Illustration Below

1. Mount cylinder as described (see Marine Installation Instructions).
2. Insert cable end into the hole in the top of the extinguisher manifold.

3. Push the cable end through the hole on the cylinder manifold far enough to allow the flexible strand to be bent.
4. Place "S" hook through the hole in the MA lever.
5. Gently pull cable sheath back into manifold, aligning the groove in sheath with slot in the manifold.
6. Insert the wire retaining clip provided around the groove in the cable sheath through the slot in the manifold securing the cable.

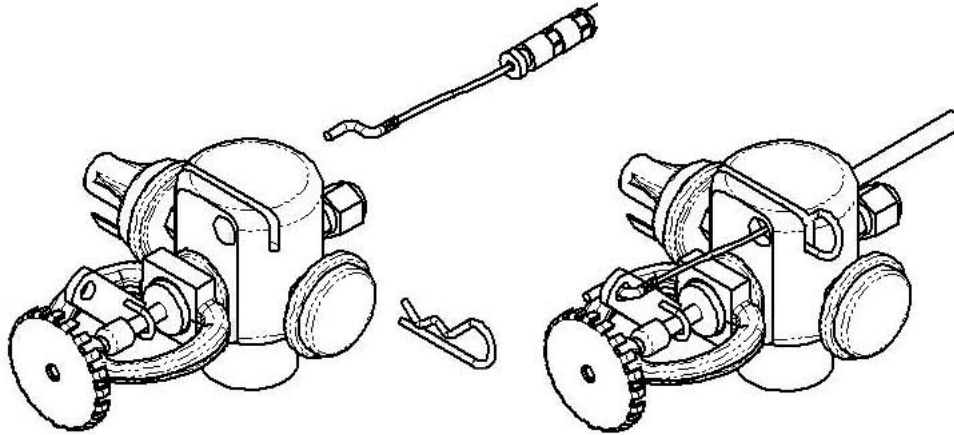

WARNING:

- With the "S" hook attached to the MA lever, and the wire retaining clip not properly installed, any pull on the cable exceeding 20lbs may actuate the fire extinguisher
- Never install, remove or service the cable when the fire extinguisher is not securely mounted in its brackets
- Always wear eye protection while servicing any component of your Fireboy fire extinguisher

Operation of Fireboy Fire Extinguisher

Automatic operation of CG2 and MA2 systems

- Actuation of a Fireboy fire extinguisher occurs at 175°F (79°C) and is entirely dependent on the intensity of the fire

Manual operation of MA2 Systems

1. Do not wait for automatic actuation.
2. Close all hatches leading to the protected compartment.
3. Shutdown all forced ventilation devices, engines, generators and electrical systems.
4. Remove the safety pin from the "FIRE" T-handle, and pull firmly.

Signs of actuation

1. A loud sound similar to small arms fire.
2. A loud sound of rushing air.
3. An extinguished indicator lamp.
4. A stalled engine.

When actuation occurs

1. Immediately shutdown all engines, powered ventilation, and electrical systems.
2. Extinguish all smoking materials.
3. Do not open the engine compartment.

After actuation

1. Before inspecting for damage, allow the agent to “soak” the compartment for at least 15 minutes and wait for hot metals or fuels to cool.
2. Have approved portable extinguishers in hand and ready for use.
3. Do not breathe fumes or vapors caused by the fire. They are hazardous and toxic.

Maintaining Fireboy Fire Extinguisher

1. Inspect the pressure gauge and the system daily.
2. Compare actuator to illustration below to determine if the extinguisher is ready or discharged.
3. Remove and weigh the complete unit (less brackets) on a certified scale every six (6) months and record on tag provided.
4. Remove fire extinguisher from service immediately for repair or replacement if weight is below what is stated on unit’s nameplate (See Limited Warranty).

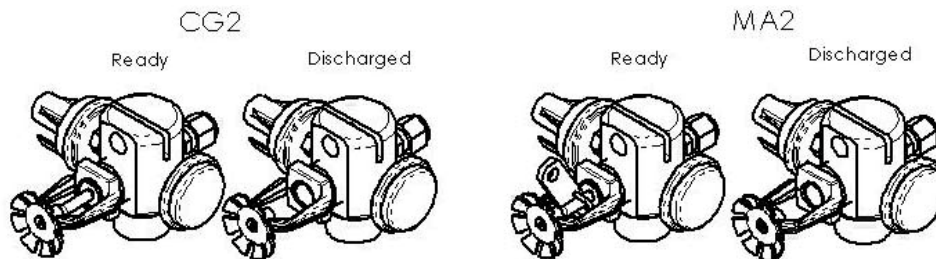

Disconnection and Inspection of Manual Discharge Cable

WARNING:

Accidental discharge during handling, installation or inspection may cause serious injury or death. Wear eye protection when installing or servicing fire extinguisher or discharge cable.

Inspect manual discharge cable annually when inspecting the fire extinguisher.

1. Do not remove the pull pin on the T-handle when disconnecting the manual discharge cable from the fire extinguisher manifold.
2. Remove the wire retaining clip securing the cable located at the slot in the top of the manifold.
3. Carefully push the cable from the backside of the manifold towards the actuator far enough to allow the flexible center strand to bend.
4. Remove the "S" hook from the black manual actuator lever.
5. Once the "S" hook is free of the lever, pull the cable back and away from the manifold.

To reconnect the manual discharge cable to the cylinder, refer to "Connecting Cable to Cylinder" in this manual.

Maintaining the Indicator Lamp Circuit

Should the indicator lamp fail to come ON when the ignition key is ON

1. Check the pressure gauge and actuator to see if the system has discharged.
2. Check fuse.
3. Using a continuity tester, check the electrical pressure switch on the system bottle itself:
 - Pull the connectors off the spade terminals and place the probes of the continuity tester directly on the spade connectors
 - A closed circuit indicates a functioning pressure switch
4. Check the continuity of the remaining wiring circuit.
5. The indicator lamp is an LED (light emitting diode) and cannot be tested with a continuity tester. A simple method to test LED's is to remove the lamp and touch the Red wire to the + terminal and the black wire to the – terminal of an ordinary 9 volt battery.
6. Should the continuity of the pressure switch indicate an open circuit, the system will have to be returned to the factory for either replacement or repair, depending upon the model involved.

Additional Equipment

Coast Guard Regulation 162.029 requires an indicator lamp be installed at each helm station from which the vessel may be operated. These additional escutcheon plates and indicator lamp kits are available factory direct or through your dealer. Outside the U.S.A. and Canada, see your dealer.

An Automatic Discharge Alarm provides both an audible and visual alarm when the system discharges. Includes a 2" round instrument with a simple three (3) wire hookup.

Automatic Engine Shutdown/Override System is required for use with Fireboy systems in diesel powered craft.

Returning Fireboy-Xintex Equipment

No product may be returned for credit or repair without a written “Returned Material Authorization” (RMA) form. Purchaser must call or email Fireboy-Xintex 616-735-9380 or fireboy@fireboy-xintex.com for a RMA. If due to extenuating circumstances a product is to be returned, after approval it must be received in 100% new/resalable condition. Products stored by the buyer for more than 26 weeks may not be returned for any reason. Maintaining fresh and current inventory is the responsibility of the buyer.

Part No.	Description
DA-1001-01I	Discharge alarm- Round Bezel
DA-1001-02I	Discharge alarm- Square Bezel
B-2174-10	Wire Harness for second station display -10'
B-2174-30	Wire Harness for second station display -30'
DRA-1001-01	Permits manual discharge of a Fireboy system from two locations
E-4209-L	Manual discharge cable - Specify length (L) in feet
ES-3000-01	3 Circuit engine shutdown system - Round Bezel (12VDC)
ES-3000-02	3 Circuit engine shutdown system - Square Bezel (12VDC)
ES-5000-01	5 Circuit engine shutdown system - Round Bezel (12VDC)
ES-5000-02	5 Circuit Engine shutdown system - Square Bezel (12VDC)
ES-5015-01	5 Circuit engine shutdown system - Time delay -Round Bezel (12VDC)
ES-5015-02	5 Circuit engine shutdown system - Time delay - Square Bezel (12VDC)
ES-8000-01	8 Circuit engine shutdown system - Round Bezel (12VDC)
ES-8000-02	8 Circuit engine shutdown system - Square Bezel (12VDC)
ES-8015-01	8 Circuit engine shutdown system - Time delay- Round Bezel (12VDC)
ES-8015-02	8 Circuit engine shutdown system - Time delay- Square Bezel (12VDC)
DU-1002-01D	Second station display for use with engine shutdown system - Round Bezel (12VDC)
DU-1002-02D	Second station display for use with engine shutdown system - Square Bezel (12VDC)
ES-3000-01-24/32	3 Circuit engine shutdown system - Round Bezel (24-32VDC)
ES-3000-02-24/32	3 Circuit engine shutdown system - Square Bezel (24-32VDC)
ES-5000-01-24/32	5 Circuit engine shutdown system - Round Bezel (24-32VDC)
ES-5000-02-24/32	5 Circuit Engine shutdown system - Square Bezel (24-32VDC)
ES-5015-01-24/32	5 Circuit engine shutdown system - Time delay -Round Bezel (24-32VDC)
ES-5015-02-24/32	5 Circuit engine shutdown system - Time delay - Square Bezel (24-32VDC)
ES-8000-01-24/32	8 Circuit engine shutdown system - Round Bezel (24-32VDC)
ES-8000-02-24/32	8 Circuit engine shutdown system - Square Bezel (24-32VDC)
ES-8015-01-24/32	8 Circuit engine shutdown system - Time delay- Round Bezel (24-32VDC)
ES-8015-02-24/32	8 Circuit engine shutdown system - Time delay- Square Bezel (24-32VDC)
ELS-3510-01	3 Circuit engine shutdown system - Low current ignition - Round Bezel
ELS-3510-02	3 Circuit engine shutdown system - Low current ignition - Square Bezel
ELS-5510-01	5 Circuit engine shutdown system - Low current ignition - Round Bezel
ELS-5510-02	5 Circuit engine shutdown system - Low current ignition - Square Bezel
ELS-8510-01	8 Circuit engine shutdown system - Low current ignition - Round Bezel
ELS-8510-02	8 Circuit engine shutdown system - Low current ignition - Square Bezel

NOTE:

Detroit Diesel engines may require Automatic Engine Shutdown systems with time delay.

Fireboy accessories are available from your Fireboy-Xintex distributor, dealer or retailer.

3 YEAR LIMITED WARRANTY

This Warranty is in lieu of all other expressed or implied Warranties

Seller warrants title, materials, and workmanship on equipment, except components manufactured by others for which the Seller assigns, as permitted, the original manufacturer's warranty. Seller's warranty shall be for a period of (3) three years from the date of sale to the ORIGINAL CONSUMER PURCHASER, during which non-conforming equipment returned to the Seller at Buyer's expense and risk, be repaired or replaced at the Seller's option. Fireboy-Xintex, Inc. will repair or replace products found to be defective in materials or workmanship within the period set forth above, provided that: (a) the product has not been subjected to abuse, contamination, neglect, accident, incorrect wiring not our own, improper installation or servicing, or used in violation of instructions furnished by Fireboy-Xintex, Inc. and (b) as to any prior defects in materials or workmanship covered by this warranty, the product has not been repaired or altered by anyone except Fireboy-Xintex, Inc and (c) the serial number has not been removed, defaced or otherwise changed, and (d) examination discloses, in the judgment of Fireboy-Xintex, Inc., does not assume the costs of removal and/or installation of the product or any other incidental costs of removal and/or installation of the product or any other incidental costs which may arise as a result of any defect in material or workmanship, and (e) upon discovery of defect, Buyer shall immediately cease use of and notify Fireboy-Xintex, Inc.

Any warranty implied by law, including warranties of merchantability or fitness, is in effect only for the duration of the expressed warranties set forth above, no person is authorized to give any other warranty, or to assume for Fireboy-Xintex, Inc. any other liability in connection with the sale of its products; Fireboy-Xintex, Inc. shall not be liable for the loss of use, revenue, or profit or for any injury, or for any other consequential or incidental damages, buyer is not relying on seller's judgment regarding his or her particular requirements, and has had an opportunity to inspect the product to his or her satisfaction.

This warranty gives you specific legal rights, and you may also have other rights, which vary, from state to state.



www.fireboy-xintex.com · fireboy@fireboy-xintex.com

P.O. Box 152
Grand Rapids, MI 49501-0152

O-379 Lake Michigan Dr. NW
Grand Rapids, MI 49534

Phone (616) 735-9380 • Fax (616) 735-9381