

**HONDA**  
ENGINES

# GX 31

Mini 4-stroke engine



1.1 kW (1.5 HP) / 7 000 min<sup>-1</sup>

Dimensions Unit: mm

**STANDARD TYPE**

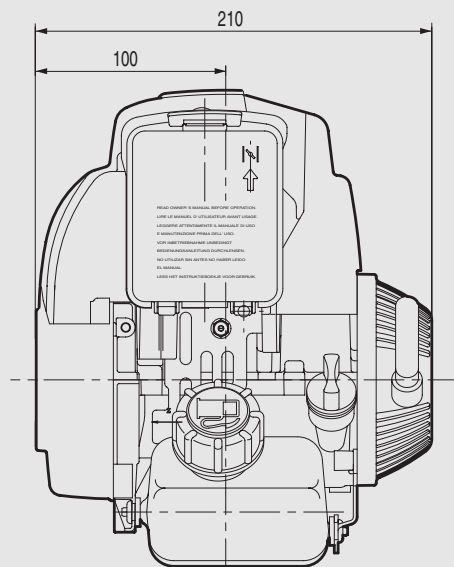
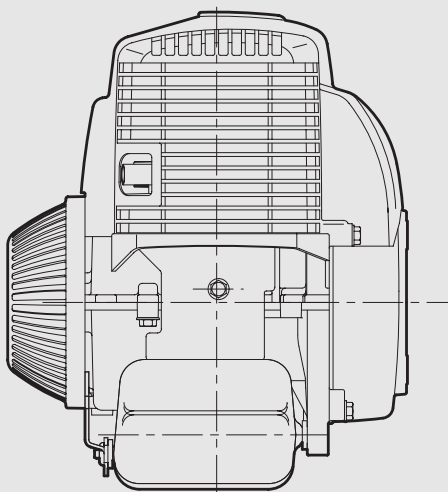
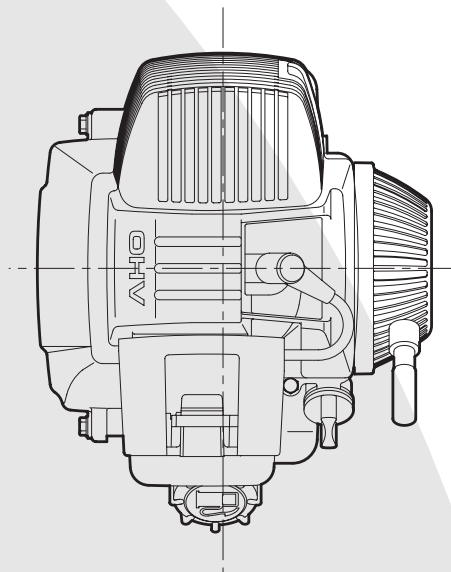
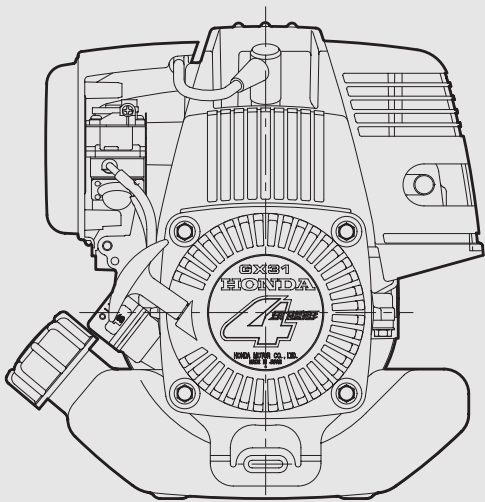

**POWERED by**  
**Honda Engines**

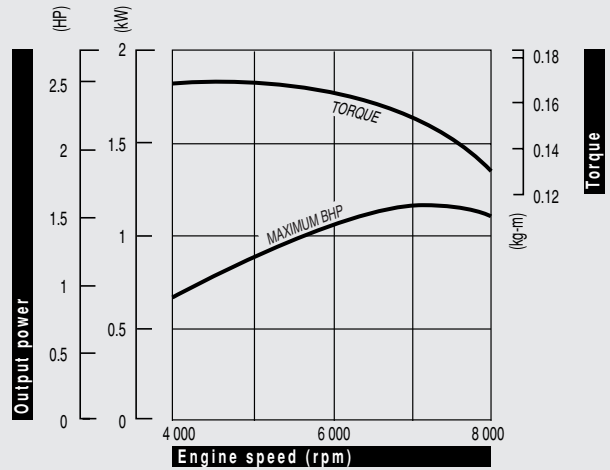
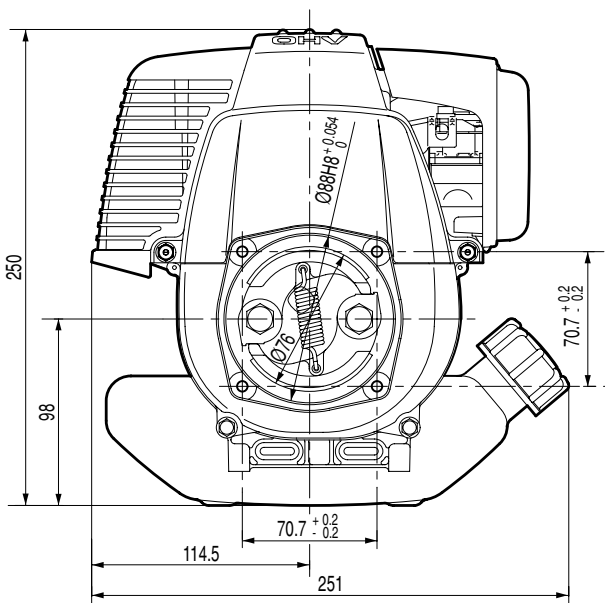
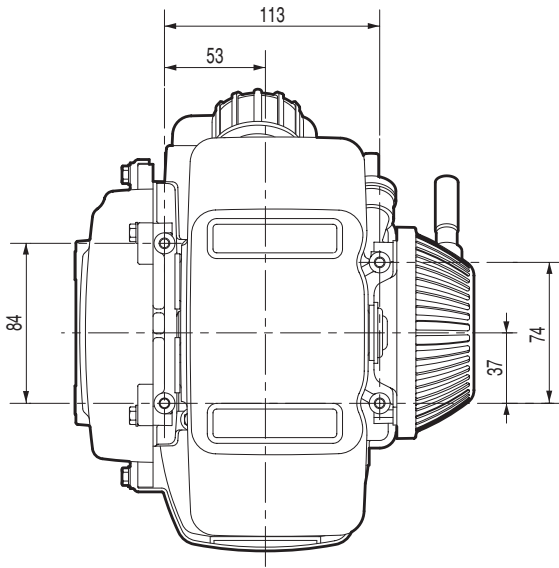

#### Performance curve

Horsepower rated in accordance with SAE J1995

For continuous operation, the BHP load should be less than 80% of maximum BHP

#### Courbe de puissance

Puissance mesurée selon SAE J1995

Pour une opération continue, la charge devrait être moins de 80% de la courbe "maximum BHP"

#### Leistungsangabe

Leistung gemessen nach SAE J1995

Für Dauerbetrieb sollte die Last weniger als 80% der "maximalen Leistungsangabe (max. BHP)" sein.

#### Curva di potenza

Potenza in conformità allo standard SAE J1995

Per uso continuativo, la potenza prelevata dovrà essere del 80% inferiore, rispetto a quella indicata nella curva "maximum BHP".

**GX 31**



## Specifications

| Model                  | GX 31                                 |
|------------------------|---------------------------------------|
| Engine type            | Air cooled 4 stroke OHV petrol engine |
| Bore x stroke          | 39 x 26 mm                            |
| Displacement           | 31 cm <sup>3</sup>                    |
| Compression ratio      | 8.0 : 1                               |
| Max. power output      | 1.1 kW (1.5 HP) / 7 000 rpm           |
| Maximum torque         | 1.64 Nm / 0.17 kgm / 4 500 rpm        |
| Ignition system        | Transistorised                        |
| Starting system        | Recoil                                |
| Fuel tank capacity     | 0.65 l                                |
| Specific fuel cons.    | 340 g/kW.hr - 250 g/HP.hr             |
| Lubrication            | Crankcase pressure driven             |
| Engine oil capacity    | 0.1 l                                 |
| Dimensions (L x W x H) | 210 x 251 x 250 mm                    |
| Dry weight             | 3.4 kg                                |

## Spécifications techniques

| Modèle                   | GX 31   |
|--------------------------|---|
| Type du moteur           | Moteur à essence monocylindre 4 temps OHV, refroidissement à air      |
| Alésage x course         | 39 x 26 mm  |
| Cylindrée                | 31 cm <sup>3</sup>  |
| Taux de compression      | 8.0 : 1   |
| Puissance maxi           | 1.1 kW (1.5 ch) / 7 000 tr/mn   |
| Couple maximal           | 1.64 Nm / 0.17 kgm / 4 500 tr/mn                                      |
| Système d'allumage       | Transistorisé   |
| Système de démarrage     | Lanceur à retour automatique  |
| Cap. du réservoir d'ess. | 0.65 l  |
| Cons. d'essence spéc.    | 340 g/kW.h - 250 g/ch.h   |
| Lubrification            | Transfert d'un brouillard d'huile par la pression du carter inférieur |
| Capacité d'huile moteur  | 0.1 l   |
| Dimensions (L x l x H)   | 210 x 251 x 250 mm  |
| Poids à sec              | 3.4 kg  |

All specifications are subject to change without notice. Les caractéristiques techniques peuvent être modifiées à tout moment et sans préavis.

## Spezifikationen

| Modell                    | GX 31   |
|---------------------------|---|
| Motortyp                  | Luftgekühlter 1-Zylinder 4-Takt OHV Benzinmotor |
| Bohrung x Hub             | 39 x 26 mm                                      |
| Hubraum                   | 31 cm <sup>3</sup>                              |
| Verdichtung               | 8.0 : 1   |
| Höchstleistung            | 1.1 kW (1.5 PS) / 7 000 min <sup>-1</sup>       |
| Max. Drehmoment           | 1.64 Nm / 0.17 kgm / 4 500 min <sup>-1</sup>    |
| Zündsystem                | Elektronische Zündung                           |
| Starter                   | Reversierstarter                                |
| Tankinhalt                | 0.65 Liter                                      |
| Spez. Kraftstoffverbrauch | 340 g/kWh - 250 g/PSH                           |
| Schmierung                | Druckschmierung                                 |
| Motorölkapazität          | 0.1 Liter                                       |
| Maße (L x B x H)          | 210 x 251 x 250 mm                              |
| Trockengewicht            | 3.4 kg  |

## Dati tecnici

| Tipo                     | GX 31   |
|--------------------------|---|
| Tipo di motore           | Motore monocilindrico OHV ciclo otto, 4 tempi, raffreddamento ad aria forzata |
| Alesaggio x corsa        | 39 x 26 mm  |
| Cilindrata               | 31 cm <sup>3</sup>  |
| Rapporto di compressione | 8.0 : 1   |
| Potenza massima          | 1.1 kW (1.5 CV) / 7 000 giri/min  |
| Coppia massima           | 1.64 Nm / 0.17 kgm / 4 500 giri/min   |
| Accensione               | A transistor senza contatti   |
| Avviamento               | A strappo con autoavvolgente  |
| Capacità serbatoio       | 0.65 l  |
| Consumo combustibile     | 340 g/kWh - 250 g/CVh   |
| Lubrificazione           | A pressione   |
| Capacità coppa olio      | 0.1 l   |
| Dimensioni (Lu x La x A) | 210 x 251 x 250 mm  |
| Peso a secco             | 3.4 kg  |

Le specifiche sono soggette a cambiamento senza preavviso. Die Spezifikationen können ohne Vorankündigung geändert werden.

Ref. EEC - TS 2002/08 - GX 31

hella@iohta.com

**Germany • Honda Engines / Selling agent**  
Honda Logistik Center Deutschland GmbH  
Spendingler Landstraße 166  
D-63069 Offenbach/Main  
TEL: + 49 (0)6 98 30 95 17  
FAX: + 49 (0)6 98 30 91 28

**United Kingdom • Honda Engines / Selling agent**  
Honda Logistics Centre (UK) Ltd.  
Unit 3210, Wellington Parkway,  
Magna Park Lutterworth,  
Leicestershire LE 17 4JQ United Kingdom  
TEL: + 44 (0)1 45 55 59 429  
FAX: + 44 (0)1 45 55 59 428

**HONDA**  
ENGINES

**Honda Europe NV**  
EUROPEAN ENGINE CENTER  
Langerbruggestraat 104 • B-9000 Gent  
TEL: + 32 (0)9 250 12 11 • FAX: + 32 (0)9 250 14 24

**Italy • Honda Engines / Selling agent**  
Honda Logistic Centre Italy S.P.A.  
Via Strà, 153  
I-37030 Colognola ai Colli (VR)  
TEL: + 39 04 56 17 33 41  
FAX: + 39 04 56 15 12 70

**France • Honda Engines / Product information center**  
Parc d'Activités de Pariest  
Allée du 1er Mai  
Croissy Beaubourg  
F-77313 Marne-La-Vallée Cedex 13  
TEL: + 33 (0)1 60 37 31 18  
FAX: + 33 (0)1 60 37 33 66