

BODYCRAFT

K1 GYM STRENGTH TRAINING SYSTEM INSTRUCTION MANUAL

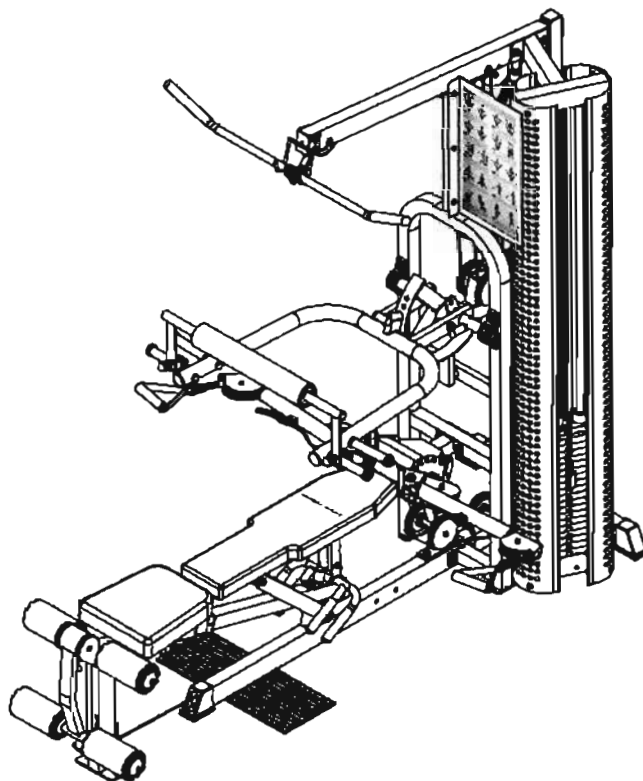

QUESTION?

As a quality home gym supplier we are committed to your complete satisfaction. If you have questions, or find missing or damaged parts, we will guarantee your complete satisfaction through our authorized dealer service centers or our home office customer service department. Please call your local dealer for assistance or RSI at 800-990-5556 (9:00 AM - 5:00 PM). Our trained technicians will provide immediate assistance to you, free of charge.

We stand behind our products. Every piece, every part of this BODYCRAFT strength training system is guaranteed for as long as you own it. We will repair or replace anything that goes wrong.

Bodycraft is a division of Recreation Supply Inc.
P.O. BOX 181
Sunbury, OH 43074

MA4109

BEFORE YOU BEGIN

Congratulations and thank you for selecting the **K1 GYM** strength training system. The **K1 GYM** offers an impressive array of strength training exercises to develop every major muscle group of the body. Whether your goal is cardiovascular fitness, a shapely, toned body or dramatic muscle size and strength, the **K1 GYM** will help you achieve the specific results you want. For your safety and benefit, read this manual and the accompanying literature before using the **K1 GYM**. Keep this manual for future reference.

If you have additional questions, please call your local dealer or our customer service department at 800-990-5556 Monday through Friday, 9 a.m. until 5 p.m. Eastern Time.

IMPORTANT SAFETY NOTES

There is a risk assumed by individuals who use this type of equipment. Before beginning this or any other exercise program consult your physician. This is especially important for individuals over the age of 35 or persons with pre-existing health problems. Recreation Supply, Inc. assumes no responsibility for personal injury or property damage sustained by or through use of this product.

1. This product must be assembled on a flat, level surface to assure its proper function.
2. Clean pads and frame on a regular basis. We recommend warm, soapy water. Do not use harsh or abrasive chemicals.
3. Inspect and tighten all parts before every use. Replace any worn parts immediately. Failure to do so may result in serious injury.
4. Keep children away from the **K1 GYM** at all times.
5. Keep your hands away from cables and pulleys during operation. Keep your hands away from moving parts other than the designated handles.
6. When adjusting the seat, make sure the spring pin is fully engaged. If not, the seat may slip and cause serious injury.
7. Make certain all cables are seated within the pulleys before every use.
8. Exercise with care to avoid injury.
9. If unsure about the proper use of the **K1 GYM** strength training system call your local dealer or our customer service department at 800-990-5556.

PARTS LIST

NO.	DESCRIPTION	QTY.
1	BASE FRAME	1
2	REAR UPRIGHT	1
3	TOP FRAME	1
4	REAR STABILIZER	1
5	BENCH PRESS UPRIGHT	1
6	BENCH PRESS ARM	1
7	SEAT SUPPORT	1
8	GUIDE ROD	2
9	BACK PAD SUPPORT	1
10	SEAT SLIDER	1
11	CHROMED CAM ASSEMBLY	1
12	CABLE ARM ASSEMBLY	1
13	TOP GUIDE ROD RETAINER	1
14	HANDLE	1
15	CABLE ARM	2
16	SQUAT HANDLE	1
17	LEG EXTENSION CABLE ARM	1
18	LEG EXTENSION ARM	1
19	FLAT POSITION SUPPORT	1
20	BACK SUPPORT PLATE	2
21	LAT BAR HOLDER	2
22	SEAT HINGE	2
23	SWIVEL CABLE TOP	2
24	FLOATING PULLEY BLOCK	2
25	SINGLE PULLEY BLOCK	1
26	SINGLE PULLEY BLOCK	1
27	PULLEY BLOCK W/SCREW	1
28	PULLEY GUARD	9
29	CABLE GUIDE PLATE	1
30	SEAT SUPPORT CLAMP	1
31	AXLE OF BENCH PRESS ARM	1
32	FOAM ROLLER HOLDER	2
33	METAL ROLLER	4
34	METAL BUSHING OF LEG EXTENSION	1
35	WEIGHT PLATE	19
36	TOP PLATE	1
37	SELECTOR ROD	1
38	BEARING HOUSING	2
39	POSTER PLATE	1
40	SHROUD	2
41	TRIM OF SHROUD	4
42	TRIM OF POSTER PLATE	1
43	LAT BAR	1
44	SNAP HOOK	3
45	SINGLE HANDLE	2
46	ANKLE STRAP	1
47	1" HAND GRIP	2
48	HAND GRIP	4
49	AXLE	1
50	PLASTIC SLEEVE FOR LAT BAR	4
51	LINK CHAIN	1

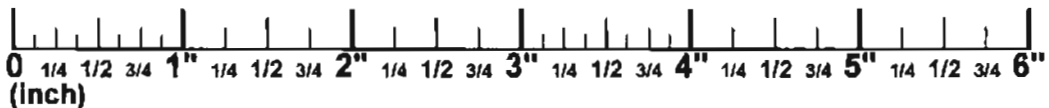
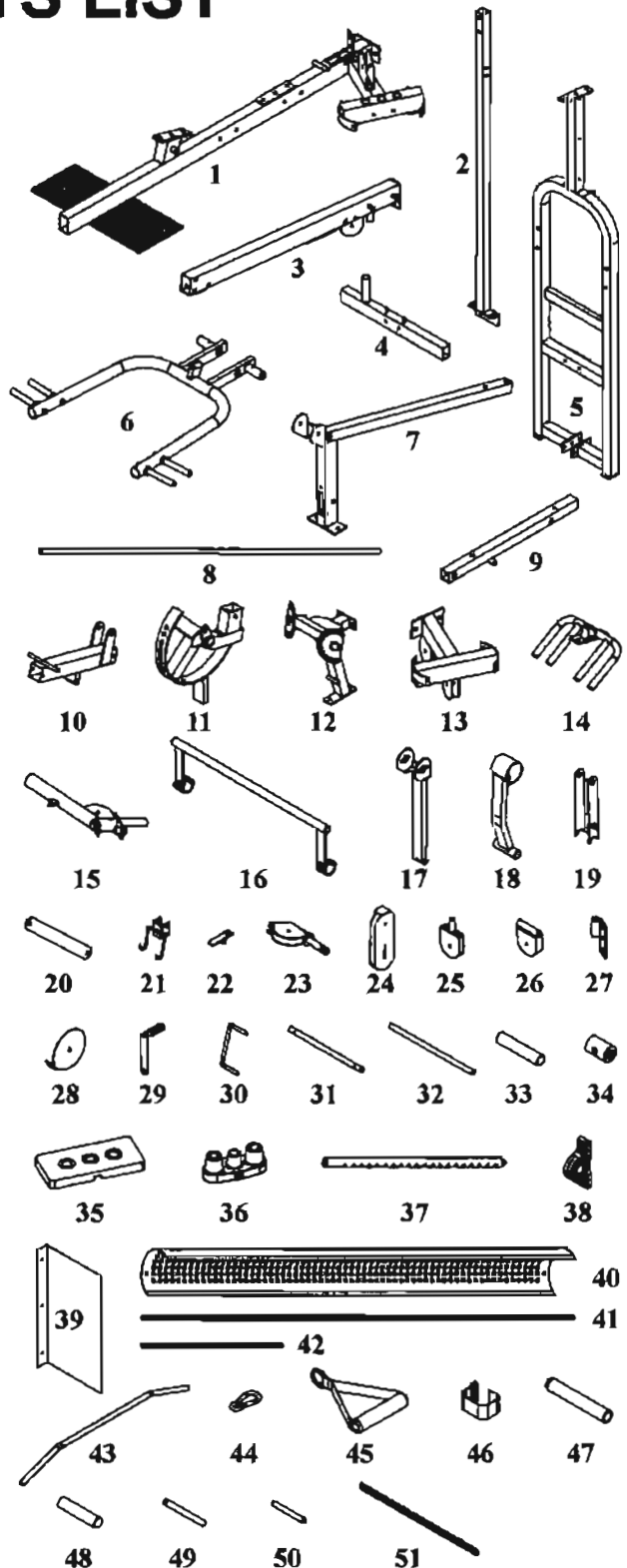

PARTS LIST

NO.	DESCRIPTION	QTY.
52	TOP CABLE	1
53	LEG EXTENSION CABLE	1
54	CONNECTING CABLE	1
55	CABLE ARM CABLE	1
56	CLUTCH CABLE	2
57	MAGNETIC SELECTOR PIN	1
58	SEAT PAD	1
59	BACK PAD	1
60	FOAM PAD	4
61	COVER OF FOAM PAD	4
62	FOAM OF SQUAT HANDLE	1
63	COVER OF FOAM OF SQUAT HANDLE	1
64	METAL CAP	4
65	115mm PULLEY	24
66	90mm PULLEY	3
67	SMALL PULLEY	2
68	50 X 75mm END CAP	2
69	50 X 75mm END CAP	1
70	50mm SQ. PLUG	5
71	50 X 75mm RECT. END PLUG	1
72	25 X 50mm RECT. END PLUG	3
73	50mm ROUND PLUG	2
74	25mm ROUND PLUG	1
75	PLASTIC COVER	4
76	PLASTIC WASHER	4
77	PLASTIC GUIDE ROD HOLDER	4
78	PLASTIC CAP	2
79	60 X 50mm BUSHING	2
80	1-1/8" STEEL BUSHING	4
81	1" STEEL BUSHING	2
82	1/2" BUSHING	10
83	3/8" BUSHING	2
84	BEARING	2
85	1" PLASTIC STOPPER	1
86	1" STOPPER	2
87	ADJ. STOPPER	2
88	RUBBER DONUT	2
89	HOOK PLATE	1
90	CABLE ARM COLLAR	2
91	STEEL SPACER	2
92	CABLE ARM AXLE COLLAR	2
93	COLLAR	2
94	SEALING RING	2
95	BEARING	4
96	BEARING BASIN	4
97	BEARING COVER	4
98	POP PIN (LONGER)	1
99	POP PIN (SHORTER)	2
100	SPRING KNOB	1
101	HANDLE	1
102	POP PIN	2

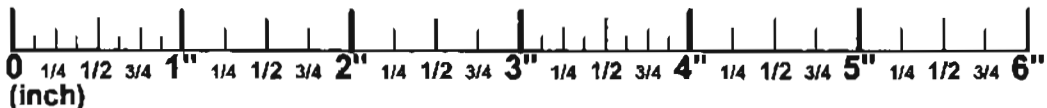

PARTS LIST

NO. DESCRIPTION QTY.

103	TOP PLATE BOLT	1
104	5/16" X 1-1/4" SET SCREW	4
105	5/16" X 3/4" SET SCREW	4
106	1/2" X 5-1/4" HEX BOLT	3
107	1/2" X 3-1/2" HEX BOLT	5
108	1/2" X 3-1/4" HEX BOLT	6
109	1/2" X 3" HEX BOLT	1
110	1/2" X 1" HEX BOLT	4
111	3/8" X 5-3/4" HEX BOLT	3
112	3/8" X 3-1/8" HEX BOLT	4
113	3/8" X 3" HEX BOLT	5
114	3/8" X 2-3/4" HEX BOLT	4
115	3/8" X 2-3/4" HEX THREADED BOLT	2
116	3/8" X 2-1/2" HEX BOLT	1
117	3/8" X 2" HEX BOLT	1
118	3/8" X 1-3/4" HEX BOLT	14
119	3/8" X 1" HEX THREADED BOLT	3
120	5/16" X 1/2" HEX THREADED BOLT	8
121	5/16" X 1-1/2" HEX BOLT	2
122	M5 X 18mm ROUND SCREW	2
123	M6 X 5/8" CONIC SCREW	4
124	5/16" X 5/8" INNER SCREW	2
125	3/8" X 5/8" INNER SCREW	2
126	3/8" X 1/2" INNER SCREW	4
127	5/16" X 1/4" SET SCREW	6
128	M6 SET SCREW	2
129	1/2" WASHER	39
130	3/8" WASHER	27
131	5/16" WASHER	13
132	3/8" SPRING WASHER	4
133	5/16" SPRING WASHER	2
134	5/16" NUT	4
135	METAL CAP	1
136	24mm NYLON NUT	2
137	1/2" NYLON NUT	18
138	3/8" NYLON NUT	30
139	5/16" NYLON NUT	2
140	M5 NYLON NUT	2

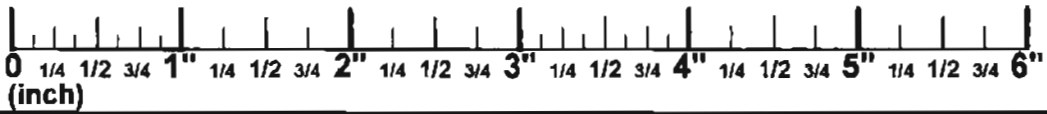
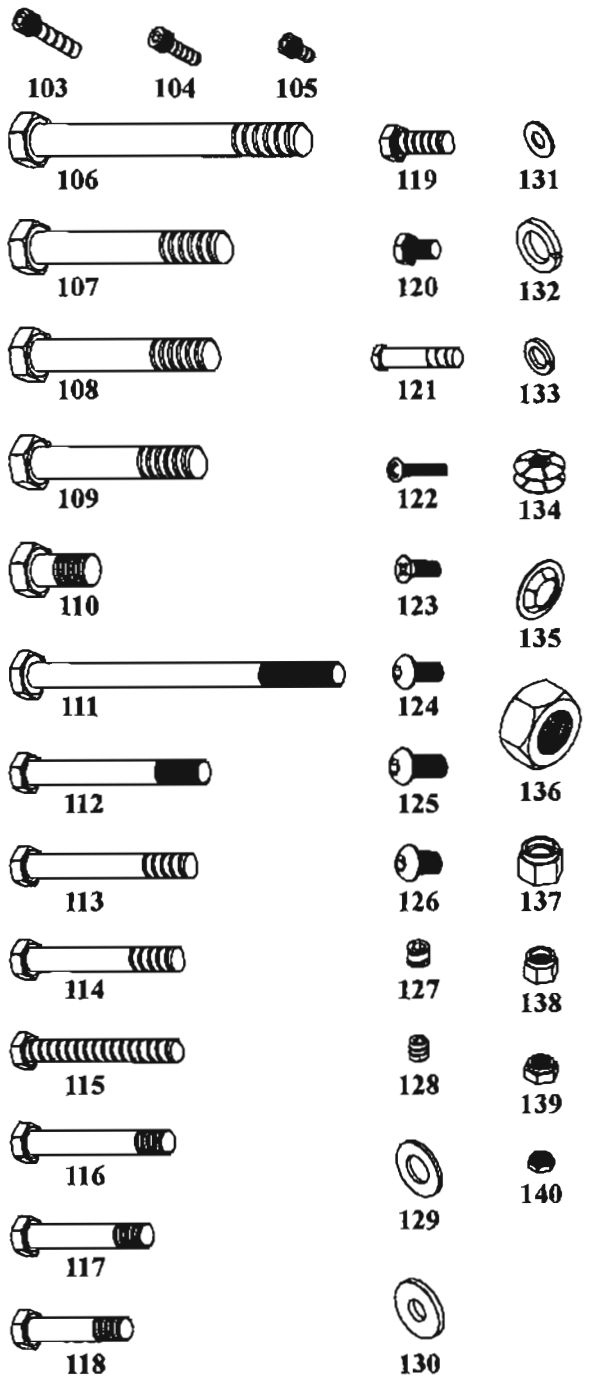

STEP 1 Base Frame Assembly

To ease the assembly process, do NOT tighten bolts until instructed.

1. Attach the Rear Stabilizer (4) to the Base Frame (1) using two 1/2" X 3-1/4" Hex Bolts (108), four 1/2" Washers (129) and two 1/2" Nylon Nuts (137). Attach the 50 X 75mm End Cap (69) to the front of the Base Frame (1) and attach two 50 X 75mm End Caps (68) to the Rear Stabilizer (4).
2. Attach the Rear Upright (2) to the bolts welded on the Rear Stabilizer (4), using two 1/2" Washers (129) and two 1/2" Nylon Nuts (137). Attach a 50mm SQ. Plug (70) to the top of the Rear Upright (2).
3. Slide the Bench Press Upright (5) over the Base Frame (1), align the holes and attach the Bench Press Upright (5) to the Base Frame (1), using two 3/8" X 3-1/8" Hex Bolts (112), four 3/8" Washers (130) and two 3/8" Nylon Nuts (138).
4. Lay the Top Frame (3) atop the Bench Press Upright (5), then attach to the Rear Upright (2), using one 1/2" X 3" Hex Bolt (109) in the top threaded hole, and one 1/2" X 3-1/4" Hex Bolt (108), two 1/2" Washers (129) and one 1/2" Nylon Nut (137) in the bottom hole. Attach the Top Frame (3) to the Bench Press Upright (5), using two 1/2" X 1" Hex Bolts (110) and two 1/2" Washers (129). Attach the Single Pulley Block (26) to the Bench Press Upright (5) using Bolt (106), two 1/2" Washers (129) and 1/2" Nylon Nut (137).
5. Insert two Plastic Guide Rod Holders (77) into the holes in the weight base on the Base Frame (1). Slide a Rubber Donut (88) onto one end of each Guide Rod (8) and then insert the Guide Rods (8) into the Plastic Guide Rod Holders (77).
6. Slide each Weight Plate (35) over the Guide Rods (8). Make certain that each plate is oriented with the selector holes on bottom and facing forward. Attach the Top Plate (36) to the Selector Rod (37) using the Top Plate Bolt (103). Tighten the Top Plate Bolts (103). Slide the Top Plate (36) and Selector Rod (37) onto the Guide Rods (8).
7. Insert two Plastic Guide Rod Holders (77) into the holes in the Top Guide Rod Retainer (13). Slide the Top Guide Rod Retainer (13) over the Guide Rods (8) and then attach the Top Guide Rod Retainer (13) to the bolts welded on the Top Frame (3), using two 1/2" Washers (129) and two 1/2" Nylon Nuts (137).
8. Attach the Lat Bar Holder (21) to the Top Frame (3) and Rear Upright (2), using four 3/8" X 3" Hex Bolts (113), eight 3/8" Washers (130) and four 3/8" Nylon Nuts (138).

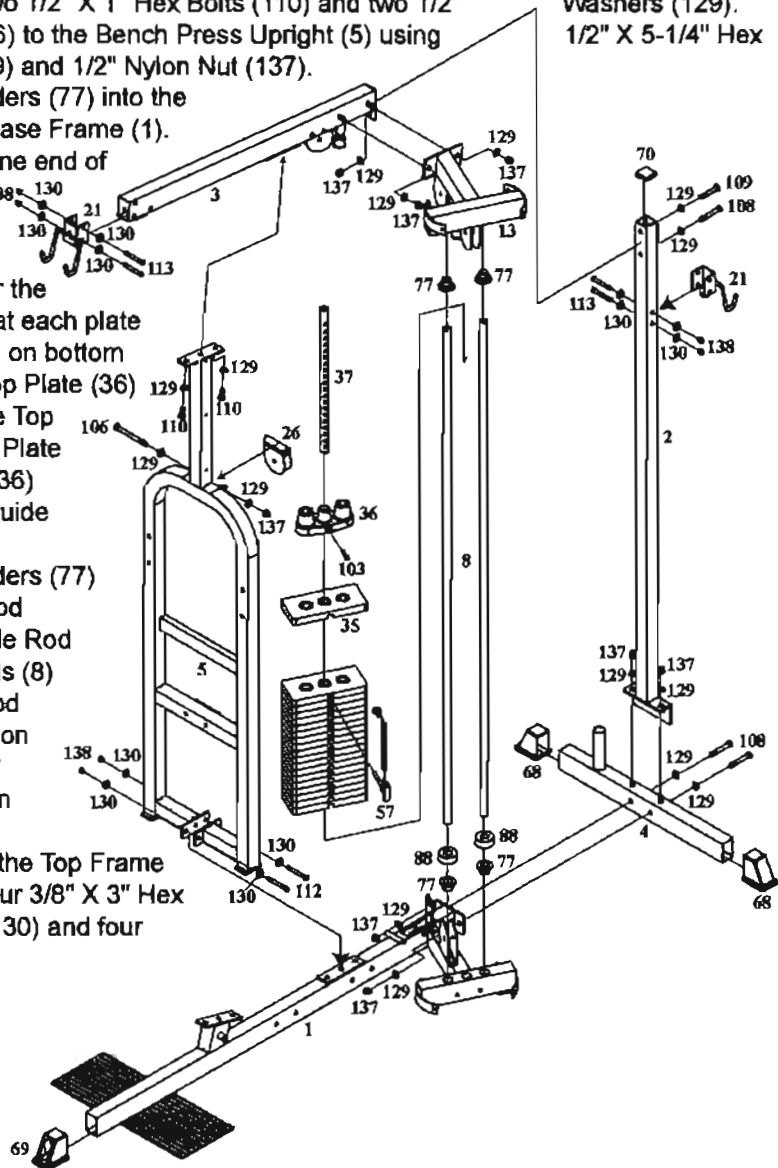

STEP 2 Cable Arm and Bench Press Assembly

We recommend two people for completion of this step.

1. Attach the Cable Arm Assembly (12) to the Bench Press Upright (5), using two 3/8" X 3-1/8" Hex Bolts (112), four 3/8" Washers (130) and two 3/8" Nylon Nuts (138). Remember to keep all bolts loose to ensure the holes will align easily. Attach the Cable Arm Assembly (12) to the Base Frame (1) using two 1/2" X 1" Hex Bolt (110) and two 1/2" Washers (130).
2. Slide the axle of each Cable Arm (15) through the holes in the selector plates in the Cable Arm Assembly (12) and then fasten using the Axle Collars (91 & 92). Tighten the set screws on the Axle Collars with a 5/16" Allen wrench. Check to ensure that each Cable Arm (15) pivots freely and that the cables are not twisted.
3. Attach the Chromed Cam Assembly (11) to the Bench Press Arm (6) by inserting the Axle of Bench Press Arm (31). Slide a Bearing Housing (38) onto each end of the Axle of Bench Press Arm (31).
4. Attach the two Bearing Housings (38) to the Bench Press Upright (5), using two 1/2" X 3-1/2" Hex Bolts (107), four 1/2" Washers (129) and two 1/2" Nylon Nuts (137).
5. Plug the back side of the Bench Press Arm (6) with two 25 X 50 mm Plugs (72), and plug the front side of the Bench Press Arm (6) with two 50 mm Round Plugs (73).

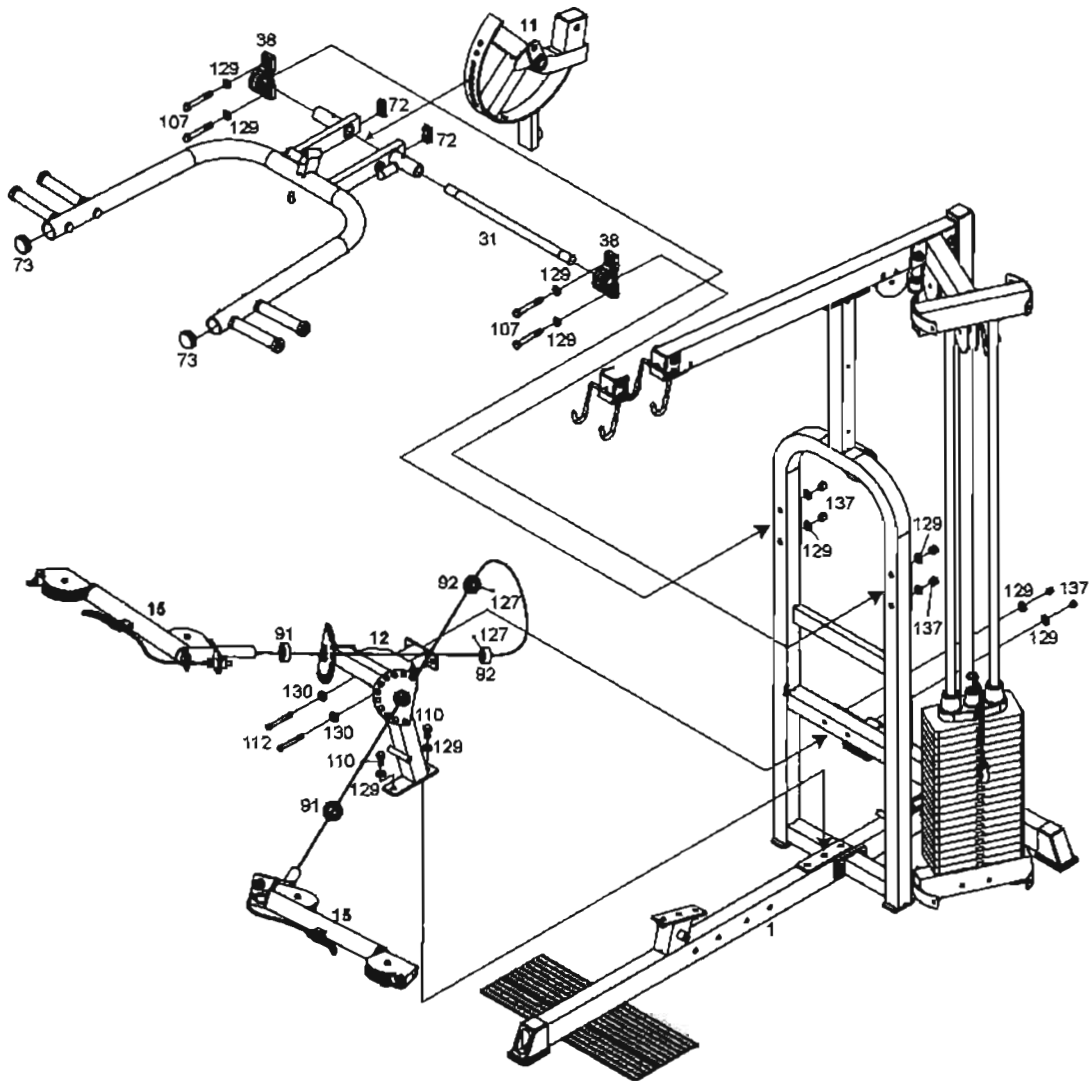

STEP 3 Seat and Leg Extension Assembly

1. Slide the Seat Slider (10) onto the Seat Support (7) and then attach the Handle Set (14) and Seat Support (7) to the Base Frame (1), using two 1/2" X 3-1/4" Hex Bolts (108), four 1/2" Washers (129) and two 1/2" Nylon Nuts (137).
2. Attach the Leg Extension Arm (18) to the Seat Support (7) by aligning the holes and then inserting the Leg Extension Axle (49). Fasten the Leg Extension Axle (49) using two 5/16" Washers (131), two 5/16" Spring Washers (133) and two 5/16" X 5/8" Inner Hex Screws (124). Double check two bearings pre-assembled on the Leg Extension Arm (18) at factory by pulling the "u" shaped spring pin and making sure it rotates freely.
3. Insert a Foam Roller Holder (32) into the tube on the front of the Seat Support (7). Insert a Foam Roller Holder (32) into the tube on the bottom of the Leg Extension Arm (18). Slide a Plastic Cover (75) onto each end of the Foam Roller Holders (32). Mount the Foam Pads (60) to the Foam Roller Holders (32). **TIP:** Moisten the center of the Foam Pads (56) with water to make it easier. Secure the Foam Pads (60) with Plastic Washers (75) and 5/16" X 1-1/4" Set Screws (104). Tighten the pre-installed 5/16" X 1/4" Set Screw (104) with an Allen wrench to help hold Foam Roller Holder (32) in place.
4. Slide the Seat Hinges (22) onto the Seat Slider (10) as shown. Screw the Seat Pad (58) to the Seat Hinges (22), using two 3/8" X 1" Hex Threaded Bolts (119) and two 3/8" Washers (130).
5. Attach the Back Support (9) to the Seat Slider (10), using one 1/2" X 3-1/2" Hex Bolt (107), two 1/2" Washers (129) and one 1/2" Nylon Nut (130). Attach the Flat Position Support (19) to the Back Support (9), using one 1/2" X 3-1/4" Hex Bolt (108), two 1/2" Washers (129) and one 1/2" Nylon Nut (130). **Note:** Use the Flat Position Support (19) when the bench is in the flat position. Fold it away when bench is in incline or decline positions. Attach both Back Support Plates (20) to the Back Support (9) and to the Base Frame (1), using (on each end) one 1/2" X 5-1/4" Hex Bolt (106), two 1/2" Washers (129) and one 1/2" Nylon Nut (137). Tighten these bolts, and then loosen just enough to allow the Plates to pivot while sliding the Seat Slider (10). Plug the 25mm Round Seat Slider (10).
6. Attach the Back Pad X 2-3/4" Hex (130). Plug both ends 50mm SQ. Plug (70).

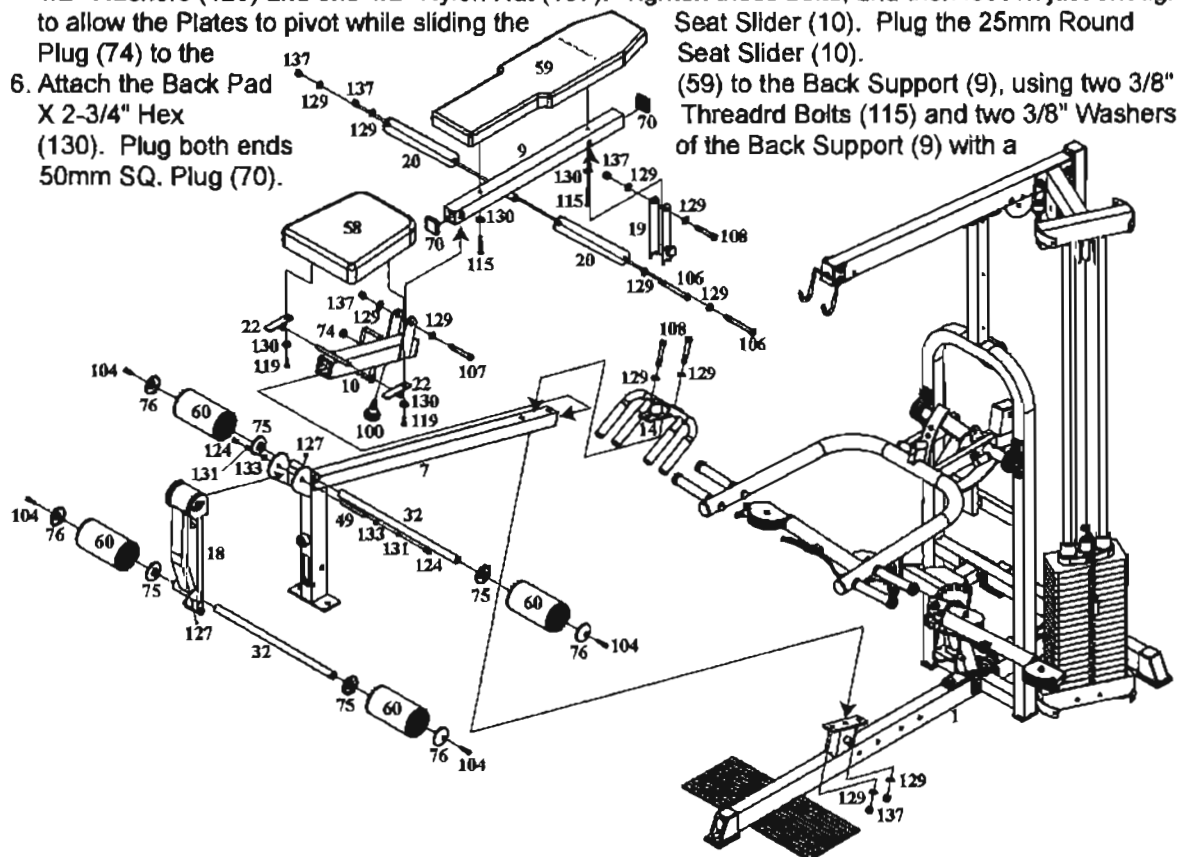

STEP 4 Top Cable Assembly



Assemble cables and pulleys simultaneously

1. Start by inserting the threaded end of the Top Cable (52) into the slot in the front of the Top Frame (3) as shown in inset T1. Then insert a pulley into the slot, making sure the cable is seated in the pulley groove and running over the top of the pulley. Attach the pulley to the Top Frame (3) using one 3/8" X 2-3/4" Hex Bolt (114), two 3/8" Washers (130) and one 3/8" Nylon Nut (138).
- 2.

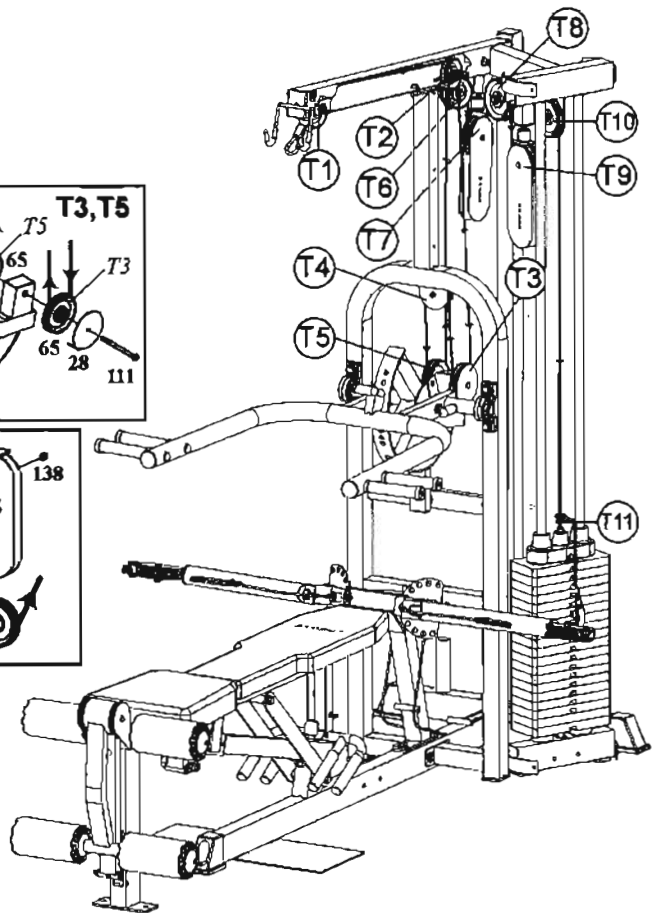
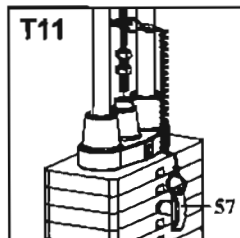
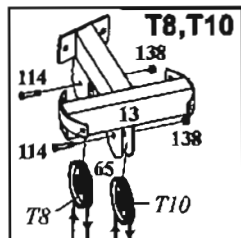
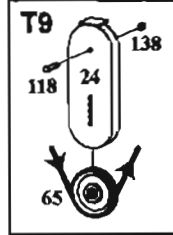
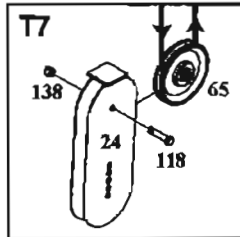
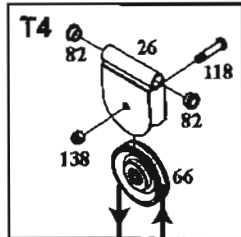
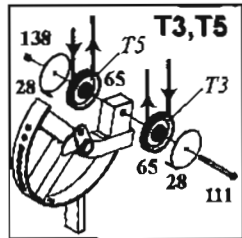
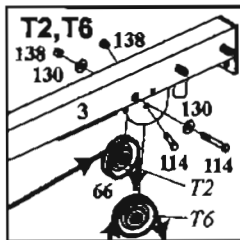
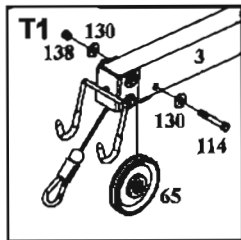

STEP 5 Install Leg Extension Cable



1.

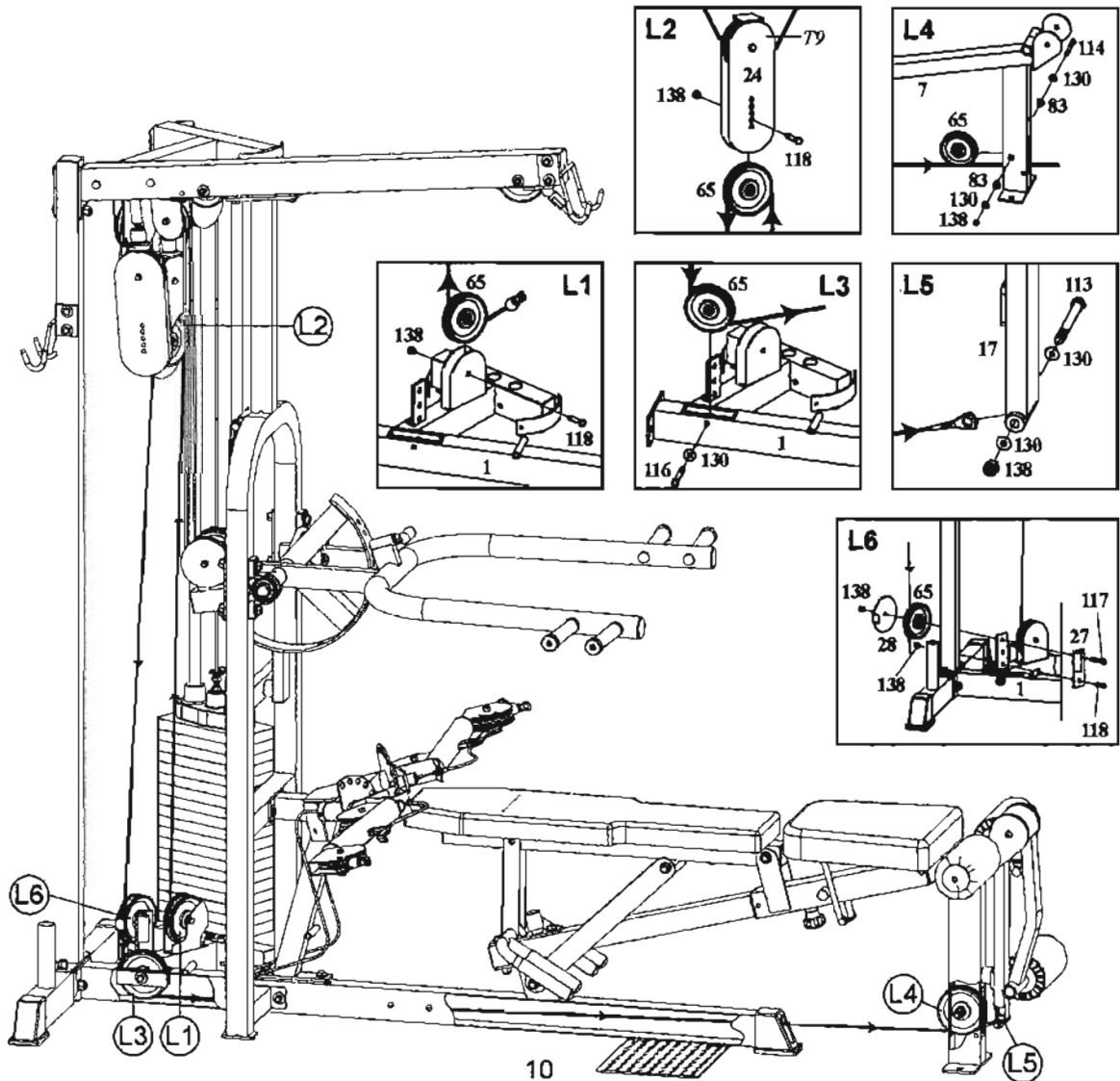

STEP 6 Install Connecting Cable



1.

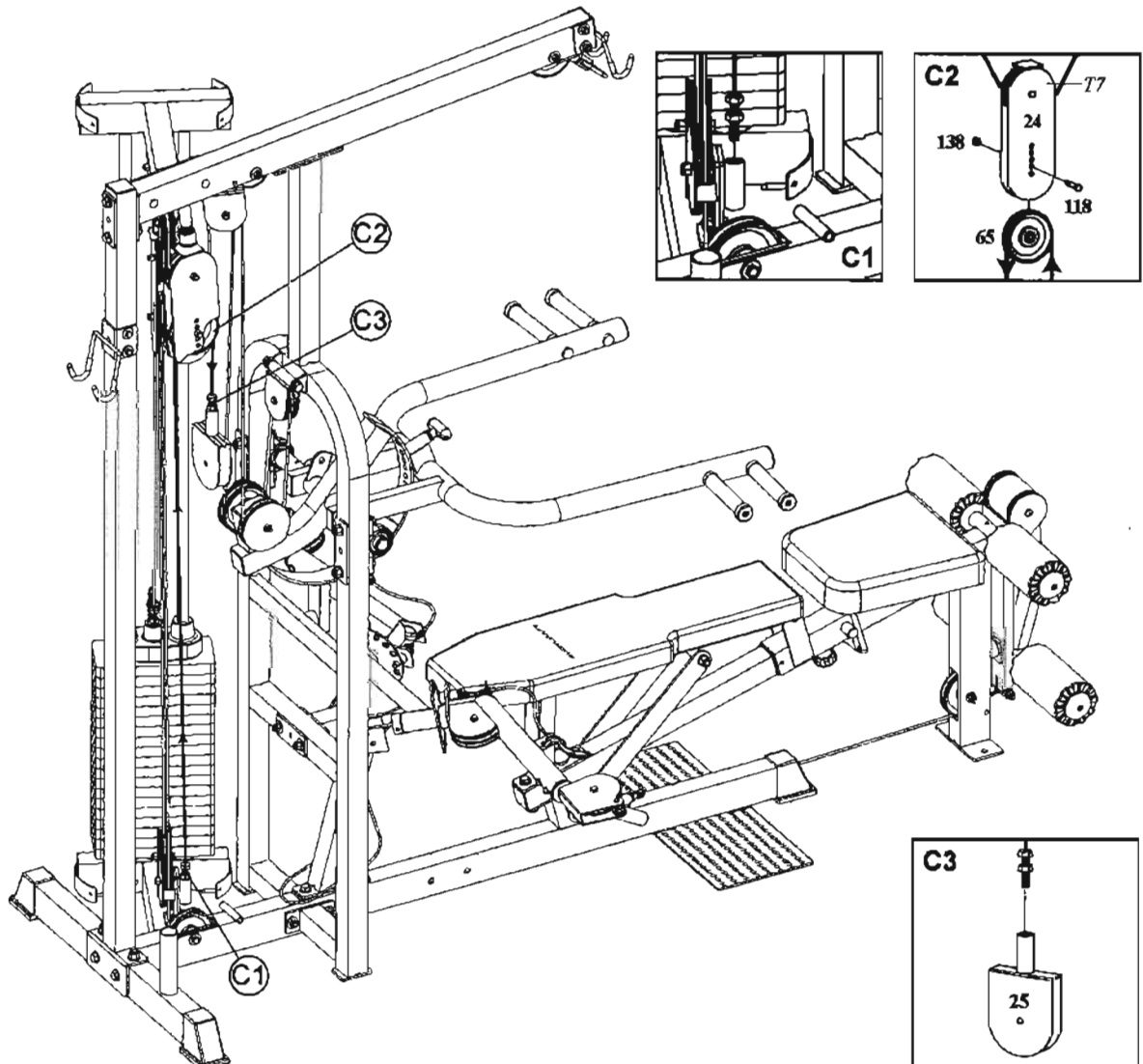

STEP 7 Cable Arm Cable



The Cable Arms and Cable are preassembled. Inset K1, K11 is there just to show you the internal components in the unlikely event you have a future internal problem. You need to complete the routing of the Cable Arms Cable (55) to the rest of the machine.

1. Attach a 115mm Pulley (65) and a Pulley Guard (28) to each side of the top of the Cable Arm Assembly (12) using one 3/8" X 1-3/4" Hex Bolt (118) and one 3/8" Nylon Nut (137) for each as shown in K3 and K9. These pulleys are located where the cable exits the rear of the Cable Arm (15). Make sure to run the cable over top of these pulleys. Tighten the bolt while making sure the Pulley Guard (28) does not rub on the cable.
2. Attach a 115mm Pulley (65) and a Pulley Guard (28) to each side of the bottom of the Cable Arm Assembly (12) using one 3/8" X 5-3/4" Hex Bolt (111) and one 3/8" Nylon Nut (138) as shown in K4, K8. One bolt for both pulleys. These pulleys are located at the base of the Cable Arm Assembly (12). Make sure to run the cable underneath these pulleys. Tighten the bolt while making sure the Pulley Guards (28) do not rub on the cable.
3. Attach the final pulley for the Cable Arm Cable (55) to the Single Pulley Block (25) dangling from the end of the Connecting Cable (54). Make sure to run the cable around the pulley. Secure the Cable Guide Plate (29) (facing upward) to the Single Pulley Block (25) as shown in inset K6, using one 3/8" X 1-3/4" Hex Bolt (110) and 3/8" Nylon Nut (138). This cable guide is included to ensure that the Cable Arm Cable (52) does not twist during use. Slip the Connecting Cable (54), which is running vertically just behind, into the slot of the cable Guide Plate (29).

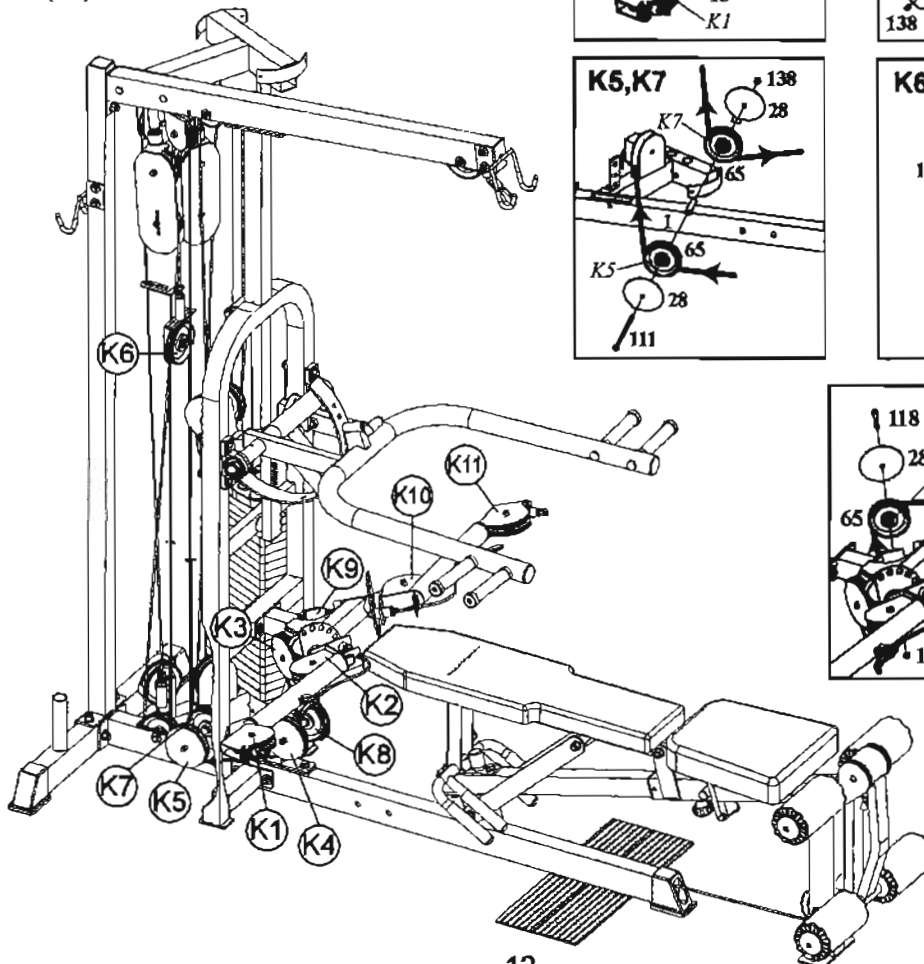
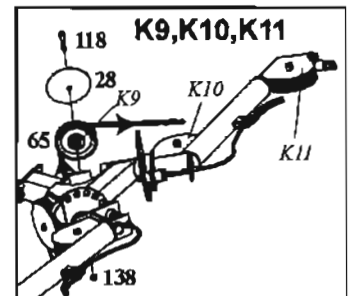
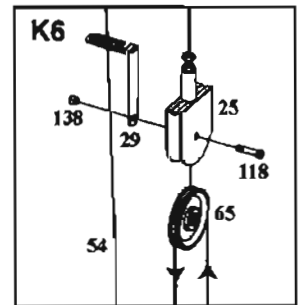
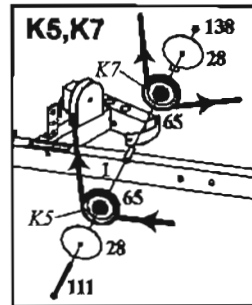
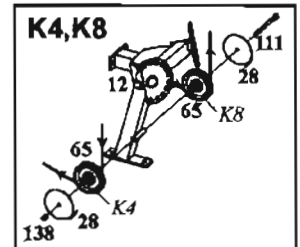
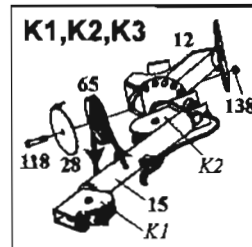

Step 8 The Cable Adjustment

- a. The Cables should be tightened to the point just before the Top Plate lifts off the stack. In other words, if the Top Plate is not resting on the stack, you will need to add length, or, if there is slack in the cables, you will need to shorten the cables. There are several adjustment points. If only minor adjustments need to be made, you can adjust the Screw ends on the Top Cable (at the Top Plate), the Low Cable (where it screws into the Single Pulley Block), or the Bench Press cable (where it screws into the Single Pulley Block with Stopper). **These ends of these cables must be screwed in at least 1/3 of their length for safety purposes.** Once you are done with these adjustments, lock them into place using the jam nuts.
- b. Broader adjustments are made at the Floating Pulley Block (24). Moving the bottom pulley toward the center decreases length (takes up slack). Conversely, moving the bottom pulley outward gains cable length.
- c. Once the cables have been adjusted to remove all slack, adjust the Adjustable Stoppers (87) in the Top Frame to where they just touch the Floating Pulley Block (24), and the Single Pulley with Stopper (87). The Adjustable Stoppers (87) aid in the function of the gym by eliminating the need to engage all cables in any given exercise routine.

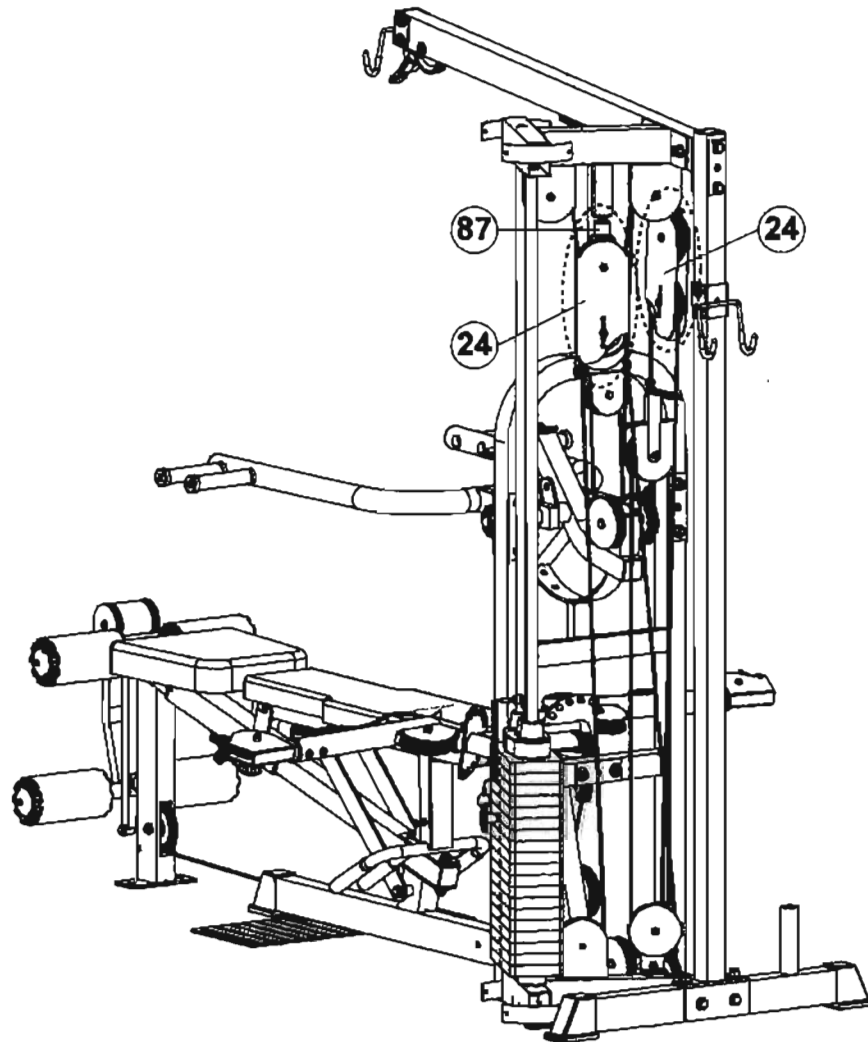

STEP 9 Shroud and Poster Plate Assembly

1. Attach the two Shrouds (40) to the Base Frame (1) and Top Guide Rod Retainer (13) using four 5/16" X 1/2" Hex Bolts (120) and four 5/16" Washers (131) on each.
2. Attach the Poster Plate (39) to the Bench Press Upright (5) using three 5/16" X 5/8" Inner Screws (124) and three 5/16" Washers (131).
3. Trim the Shrouds (40) and Poster Plate (39) with the provided Plastic Trim (41 & 42). You may need to cut the trim to proper length.

Now tighten all bolts. First, tighten the bolts at the base of the Rear Upright, where it attaches to the Rear Stabilizer. Then tighten all bolts, working your way from the base of the gym to the top of the gym. Check to ensure all bolts are tight, all cables are tight and cables are seated into the pulley grooves.

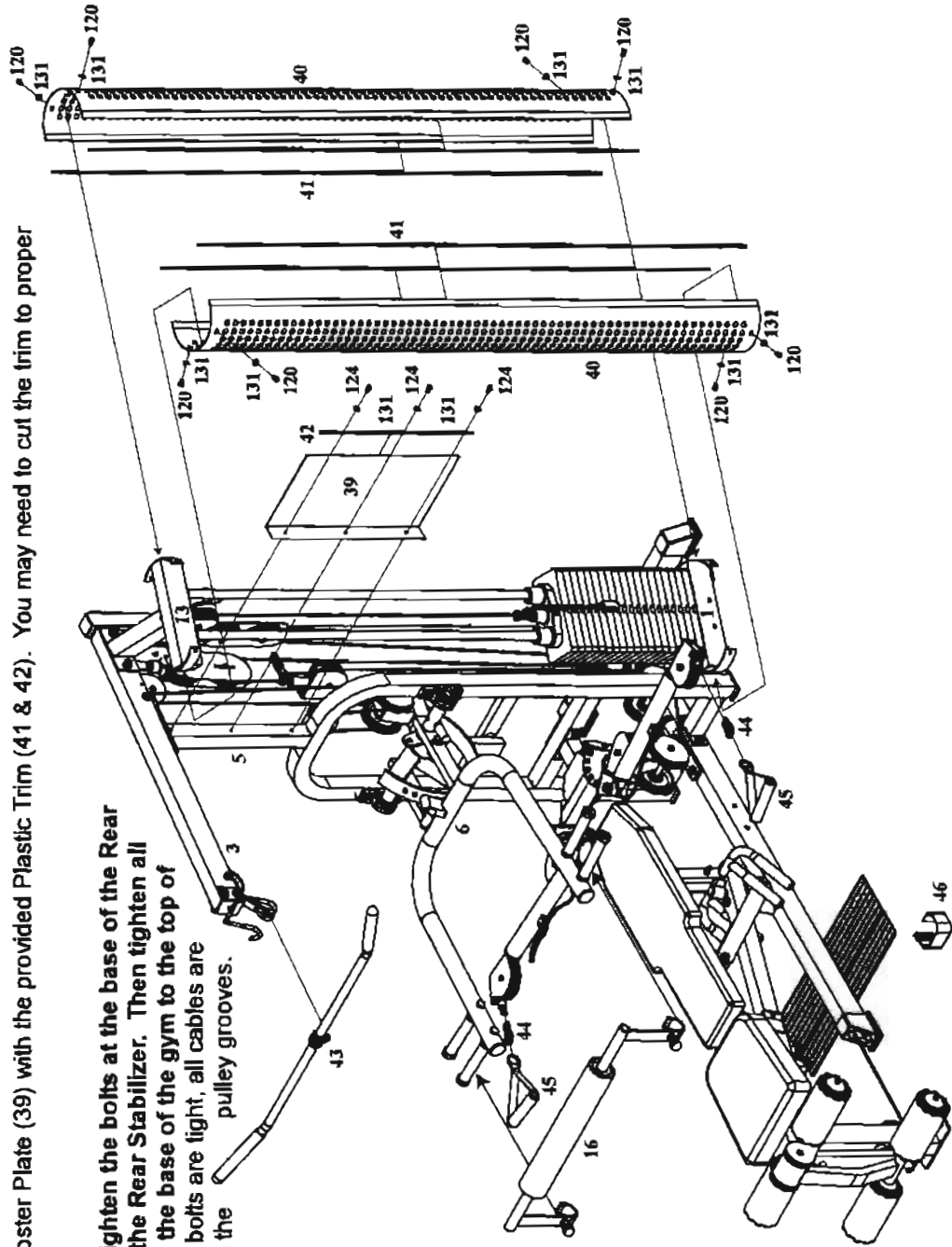

Assembly is complete! Please take the following steps before using the gym:

1. Make certain all bolts are tightened securely.
2. Make certain all cables are seated into all pulley grooves. A cable rubbing against steel will peel the nylon coating, voiding warranty and resulting in a need for replacement.
3. Pre-stretch the cables. Put the Magnetic Selector Pin (90) in the bottom hole on the weight stack. Pull on the cables with great force, helping remove any kinks and providing any initial cable stretch.
4. Be aware the cables can loosen and slightly stretch upon initial use.
5. The cables should be adjusted as tight as possible, but not so tight as to lift the Top Plate (36) above the weight stack. Be certain to secure the jam nuts after adjustments are made.
6. For better performance, apply a household lubricant (such as silicone) to any adjustable areas and to the Guide Rods (8).
7. Enjoy many years of a Fit Lifestyle.

Thank you for purchasing the K1 Gym. If You have any questions, please call your local BodyCraft dealer or call our customer service department at 800-990-5556