



ic1101
MASSAGE CHAIR
FAUTEUIL DE MASSAGE

USER MANUAL
MANUEL DE
L'UTILISATEUR





**PLEASE DO NOT RETURN
THIS PRODUCT TO THE STORE**

**FOR QUESTIONS OR ASSISTANCE ON ASSEMBLY, PARTS OR OPERATION,
CONTACT OUR CUSTOMER SERVICE!**

**S'IL VOUS PLAÎT, NE RENVOYEZ PAS
CE PRODUIT EN MAGASIN**

**POUR TOUTE QUESTION OU AIDE CONCERNANT LE MONTAGE,
LES PIÈCES OU LE FONCTIONNEMENT,
CONTACTEZ NOTRE SERVICE À LA CLIENTÈLE!**

**TOLL FREE CUSTOMER SERVICE /
SERVICE À LA CLIENTÈLE SANS FRAIS**

1 866 967.7333 ext. 227





Thank you for purchasing this product. Please read this instruction manual carefully before operating this massage chair.

Please pay attention to the important safety warnings and keep this manual for future use.

Note: EBI reserves the right to revise the design and description of this product without notice.

CONTENTS

1. Safety warnings.....	2
2. Environment.....	2
3. Restrictions.....	3
4. Maintenance.....	3
5. Troubleshooting.....	3
6. Features and benefits.....	4
7. Installation.....	4
8. Components.....	8
9. Operation.....	10
10. Floor protection.....	11
11. Product specifications.....	11
12. Warranty.....	12
FRANÇAIS.....	13





2



1. SAFETY WARNINGS

- This product is not recommended for children.
- Disconnect the chair before cleaning.
- Please pull out the plug after use or before cleaning to avoid injury or damage to the product.
- Please operate this product according to the instructions in this manual.
- Use only accessories recommended by iComfort®.
- This product is designed for indoor use only.
- Recommended use time is 30 minutes or less.
- Please avoid use if the chair is damaged and call your iComfort® technician or dealer.
- Make sure the chair radiator in the lower back behind the chair is well ventilated and not obstructed.
- Please make sure small objects are not dropped into the chair mechanism.
- Use of this chair under the influence of drugs or alcohol is not recommended.
- Do not use wet hands to pull the AC cord.
- Do not spill liquids onto this product to avoid electric shock or cause damage to this product.
- Maintain your chair and avoid damaging the wires.
- Do not use a wet cloth to clean the electric parts.
- In the event of a power failure disconnect the chair.
- If the chair works abnormally, stop using it, disconnect the chair and call your iComfort® service technician or customer service representative.

2. ENVIRONMENT

This chair should be used only in a well ventilated, normally dry and dust free environment.





3. RESTRICTIONS

People with osteoporosis, heart disease and heart pacemakers, pregnancies, injuries or any other health related issues should consult their doctor before using this massage chair.

Stop immediately the use of this massage chair if you feel unwell and consult your doctor.

4. MAINTENANCE

- This product should only be maintained by iComfort® certified technicians. Otherwise, EBI reserves the right to void the warranty.
- Disconnect the power cord after use.
- Make sure the wall outlet is in good working order before use.
- If this chair will not be used for an extended period of time, store in a dry and dustless environment.
- Avoid chair exposure to high temperatures and direct sunlight.
- Clean this product with a dry cloth. Do not use thinner, benzene or alcohol.
- When moving the chair on wood floor, rough ground or in a narrow space two people should lift the chair together.
- We recommend to use the massage chair intermittently and not for long time periods.

5. TROUBLESHOOTING

- It is normal for the motor to make noise while in use.
- If the controller doesn't work normally, please check that the plug and socket are properly connected and the switch is turned on.
- When the programmed working time is over, the chair will power-off automatically.
- After several use, the chair might power-off because of overheat. It can be used again after half an hour of cooling time.





4



6. FEATURES AND BENEFITS

Enjoy a fabulous massage with the iComfort® ic1101 Massage chair. You will feel as if you had your very own massage therapist. The iComfort® ic1101 massage chair reproduces 2 massage actions with vibration and heat. It will provide you with comfort, heat and massage all at the same time. The iComfort® ic1101 Massage chair will provide you with many years of soothing massage and comfort.

- Contemporary design with high-quality soft touch leatherette.
- 2 massage types: vibration and heat.
- 8 vibrating massage mechanism.
- The LED remote control indicates the type of massage being performed.
- Manual recline function.
- Rotatable feature.
- Ergonomic angled ottoman for superior comfort.

7. INSTALLATION

The ic1101 massage chair comes partly assembled.







- Assemble this MASSAGE CHAIR according to the installation instructions provided in this guide.
- Check the parts list carefully to make sure nothing is missing.

CAUTION: Never substitute a missing part with one of your own. If a part is missing, contact customer service at: **1-866-967-7333 ext 227**

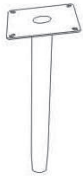

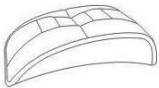

7. 1. INCLUDED CHAIR PARTS

A		1	E		1
B	 M8 X 20	2	F		1
C		1	G		1
D	 M6 X 15	4	H		1





6



7. 2. ASSEMBLY

7. 2. 1. Backrest and seat cushion installation

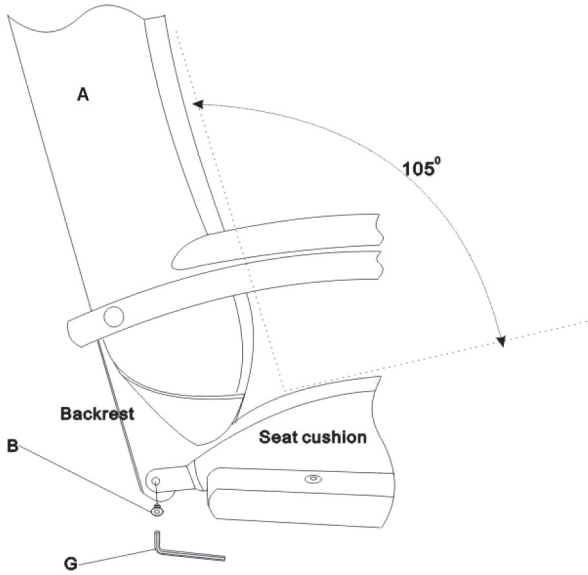

7. 2. 2. Ottoman installation

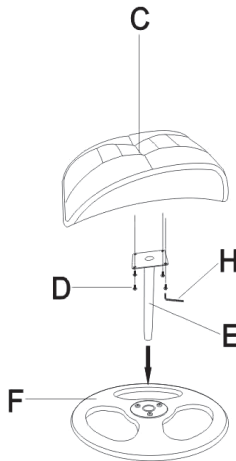



7. 2. 3. Remote control and AC connection



WARNING

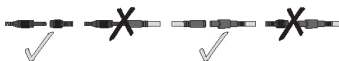

7. 2. 4. Recommended space behind and in front of the massage chair



You can now enjoy the comfort of your new chair!





8



8. COMPONENTS





Remote control



1. ON/OFF button
2. Command function buttons
3. Intensity level display
4. Massage time display
5. Auto massage mode and heat function display
6. Massage area indicator display





10



9. OPERATION

This relaxation massage chair can be rotated 360° and the backrest and the seat can be set between 105° and 145°.

Reclining action

1. To recline the backrest:
 - Make sure nothing blocks the sides and the rear of the massage chair before reclining the backrest.
 - Pull the lever located on the side of the armrest, then stretch out your body against the backrest.
2. To lift up the backrest in its original position:
 - Pull the lever toward the front to lift up the massage chair in a sitting position. To activate the massage chair features, press lightly on the control panel buttons.

POWER

Press the Power button to turn on the massage function. The LED indicator will illuminate and confirm your selection. To turn off the massage functions simply press the button again. When the power is activated, the following automatic functions are activated: low intensity, massage program no.1 and the 30 minutes timer.

INTENSITY

Press the "INTENSITY" button to choose the intensity of the massage. You can select between ten intensity levels displayed on the remote control.

TIMER

Press the "TIMER" button to select the desired massage time. You can select between 1 to 99 minutes (auto mode is 30 minutes), when the time is up, the massage action stops and the LED lights will turn off.

MASSAGE AREA

Press and hold the "HOLD" button to select the massage area. The massage areas are displayed on the remote control.





PROGRAM

Press the “MODE” button to select your massage program. There are ten different massage programs, each with its own personality. The program chosen is displayed on the remote control.

HEAT

Press this button to activate the heating function. It takes about 3 minutes to feel the heat. Press again to turn it off. When the temperature reaches 30-35°C, heating stops automatically. It turns back on automatically when it reaches 20°C.

10. FLOOR PROTECTION

Prolonged use of this massage chair can damage wood floors. In order to prevent permanent damage, place a carpet or mat under the chair.

11. PRODUCT SPECIFICATIONS

Weight: 25 kg

Power: 120 Watts

Voltage: 110V, 60 Hz





12. WARRANTY

LIMITED ONE (1) YEAR WARRANTY

This product is guaranteed against all manufactured faults and defects for a period of One (1) year from the date of purchase.

For repairs or product defects, please call our customer service department at: **1-866-967-7333**. Please have your proof of purchase on hand. If we are not able to replace your defective part, we will send you a service technician for repairs.

Important notes: Any damages caused by an accident or an abusive usage are **NOT** covered under warranty. We also decline all responsibility concerning indirect or consecutive damages. In certain Canadian provinces, it is not permitted to limit indirect or consecutive damages. Therefore it is possible these limitations are not applicable to you. This warranty gives you specific legal rights. You may also have other legal rights which vary from one province to another.

CUSTOMER SERVICE: 1-866-967-7333 ext 227



		Warranty Registration card	
Carte d'enregistrement de garantie			
<input type="text"/>		<input type="text"/>	
First Name - Prénom		Last Name - Nom	
<input type="text"/>			
Address - Adresse		City - Ville	Prov Postal Code - Code Postal
<input type="text"/>		<input type="text"/>	
Tel - Tél.		Email - Courriel	
<input type="text"/>		<input type="text"/>	
Purchase Date - Date d'achat		Purchased From - Acheté de	
<input type="text"/>		<input type="text"/>	
Serial Number - Numéro de série		Warranty must be active within 30 days of purchase. La garantie doit être enregistrée dans les 30 jours suivant l'achat.	
Send to – Expédier à :			
EBI			
120 Boul. des Entreprises, Boisbriand (Québec) J7G 2T3 Tel – Tél. : 1-866-967-7333 Fax – Téléc. : 450-420-2180			
<input type="text"/>		Date	
<input type="text"/>		<input type="text"/>	
		Signature	





Merci d’avoir acheté ce produit. Veuillez lire attentivement toutes les directives avant d’utiliser votre fauteuil vibromasseur et conservez cette notice d’utilisation.

Portez attention aux consignes de sécurité et conservez cette notice d’utilisation afin de pouvoir vous y référer ultérieurement.

Note: EBI se réserve le droit de modifier le design et la description de ce produit sans autre préavis.

TABLE DE MATIÈRES

- 1. Consignes de sécurité 14
- 2. Environnement d’utilisation 14
- 3. Contre-indications 15
- 4. Entretien 15
- 5. Dépannage 15
- 6. Avantages et bénéfices 16
- 7. Installation 16
- 8. Composantes 20
- 9. Mode d’emploi 22
- 10. Protection du plancher 23
- 11. Spécifications techniques 23
- 12. Garantie 24





1. CONSIGNES DE SÉCURITÉ

- Ce produit n'est pas recommandé pour les enfants.
- Veuillez débrancher la chaise avant de la nettoyer.
- Utilisez cet appareil exclusivement aux fins décrites dans la présente notice.
- Veuillez n'utiliser que les accessoires recommandés par iComfort.
- Cet appareil est conçu pour un usage intérieur seulement.
- Cet appareil est conçu pour un usage de 15 minutes ou moins à la fois.
- En cas de bris de l'appareil (tissus ou mécanique), débranchez celui-ci et appelez un centre de service iComfort ou votre revendeur.
- Assurez-vous que le radiateur de l'appareil en bas et au dos de celui-ci est bien aéré et non-obstrué.
- Veuillez à ne pas laisser tomber de petits objets dans les orifices et mécanismes de la chaise.
- L'utilisation de cette chaise n'est pas recommandée en cas d'abus d'alcool ou de drogues.
- Ne tenez pas la fiche d'alimentation avec des mains mouillées.
- N'échappez pas de liquides sur cet appareil afin de réduire les risques de décharges électriques et éviter de l'endommager.
- Maintenez votre chaise en bonne condition et veuillez ne pas endommager la fiche d'alimentation.
- N'utilisez pas un linge mouillé pour nettoyer des composantes électriques telles que l'interrupteur ou la fiche d'alimentation.
- Éteignez l'appareil lors d'une panne de courant.
- Cessez d'utiliser votre fauteuil vibromasseur s'il fonctionne anormalement. Coupez immédiatement l'alimentation et contactez le service après-vente.
- Cessez d'utiliser l'appareil si vous ressentez un malaise et consultez votre médecin.

2. ENVIRONNEMENT D'UTILISATION

Cet appareil est uniquement conçu pour être utilisé dans un environnement sec, bien aéré, tempéré et sans poussière.





3. CONTRE-INDICATIONS

Il est fortement recommandé pour les personnes ayant des problèmes cardiaques, d'ostéoporose, de fièvres, fractures, d'une chirurgie récente, dislocation ou qui portent un stimulateur cardiaque, défibrillateur ou autres appareils de santé électroniques sensibles aux interférences, de consulter leur médecin avant d'utiliser ce produit.

4. ENTRETIEN

- Cet appareil doit être entretenu uniquement par un technicien recommandé par iComfort. Dans le cas contraire, EBI se réserve le droit d'annuler la garantie de cet appareil.
- Débranchez le cordon d'alimentation après chaque utilisation.
- Veuillez ne brancher cet appareil que sur des prises murales en parfait état de marche.
- Si l'appareil demeure inutilisé pendant une période de temps prolongée, entreposez-le dans un endroit sec et exempt de poussière.
- Ne rangez pas cet appareil près d'une source de chaleur élevée, d'un feu ou sous la lumière directe du soleil.
- N'utilisez pas de benzène, de décapant ni d'autre solvant pour nettoyer l'appareil. Utilisez plutôt un linge sec.
- Le mécanisme de cet appareil est conçu pour en minimiser l'entretien.
- Si vos planchers sont en bois, si vous êtes dans un espace trop étroit ou si la surface du sol est accidentée. Dans ces cas précis, deux personnes seront requises pour soulever et déplacer le fauteuil.
- Utilisez cet appareil de façon intermittente. Ne l'utilisez pas de façon continue pendant de longues périodes de temps.

5. DÉPANNAGE

- Il est normal que le moteur fasse du bruit pendant que l'appareil fonctionne.
- Si le panneau de commande ne fonctionne pas normalement, assurez-vous que le cordon d'alimentation et la prise d'alimentation sont bien connectés et que l'interrupteur est allumé.
- L'appareil s'arrête automatiquement lorsque le temps prescrit s'est écoulé. L'appareil s'éteindra également automatiquement pour éviter que le moteur surchauffe lorsqu'il a fonctionné continuellement sur une longue période de temps. Il pourra, à nouveau, être utilisé après trente minutes d'arrêt.



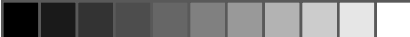

6. AVANTAGES ET BÉNÉFICES

Profitez d'un massage vivifiant avec la chaise massage ic1101 de iComfort®. Son design contemporain contribue à enjoliver le décor de votre pièce. Une fois les fonctions de massages activées, vous aurez l'impression d'avoir votre massothérapeute personnel. Elle reproduit 2 thérapies de massage dont la vibration et la chaleur en tout confort. La chaise massage ic1101 de iComfort® vous offre un massage performant, une chaleur réconfortante ainsi qu'un confort hors paire et ce en même temps. Elle saura vous offrir massages et confort pendant de longues années.

- Conception contemporaine avec similicuir souple de haute qualité pour un confort sans égal.
- 2 modes de massage: vibration et chauffage.
- Mécanisme de massage à vibration à 8 moteurs.
- Commandes de contrôle à DEL indiquant le type de massage en cours.
- Réglage manuel de l'inclinaison de la chaise.
- Chaise de massage rotative.
- Ottoman à angle ergonomique.

7. INSTALLATION

La chaise de massage ic1105 est partiellement assemblée.







- Assemblez la chaise de massage selon les instructions d'installation fournies dans ce guide.
- Vérifiez la liste des pièces soigneusement pour s'assurer que rien ne manque.

ATTENTION: Ne jamais remplacer une partie manquante avec l'une des vôtres. Si une partie est manquante, contactez le service à la clientèle au : **1-866-967-7333 ext 227**

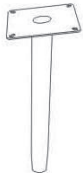

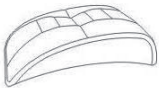

7. 1. LISTE DES PIÈCES

A		1	E		1
			F		1
B	 M8 X 20	2			
C		1	G		1
D	 M6 X 15	4	H		1





7. 2. INSTALLATION

7. 2. 1. Installation du siège et de l'appui-dos

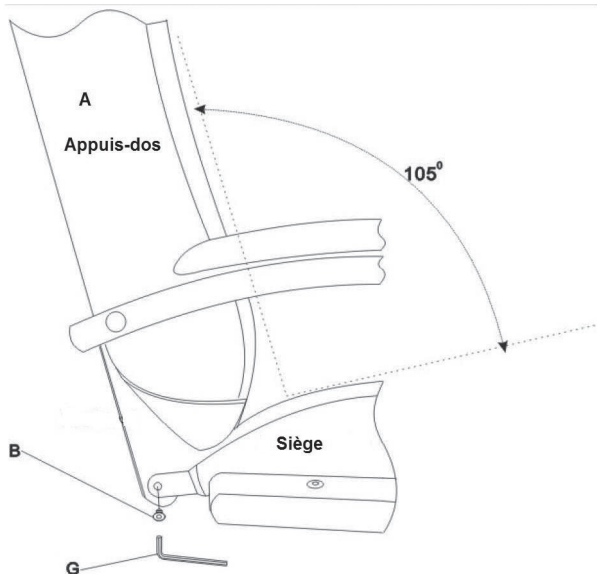

7. 2. 2. Installation de l'ottoman

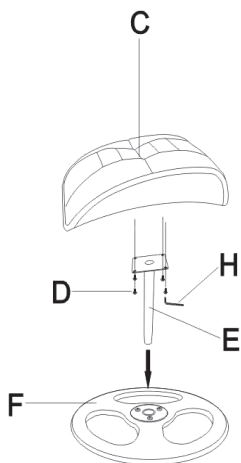



7. 2. 3. Branchement de la commande à distance et de la prise CA



WARNING



7. 2. 4. Espace recommandé devant et derrière la chaise de massage



Vous pouvez maintenant profiter du confort de votre nouvelle chaise massage





20



8. COMPOSANTES





Remote control



1. Bouton d'ACTIVATION/DÉSACTIVATION (ON / OFF)
2. Touches de fonction
3. Affichage du niveau d'intensité
4. Affichage de la minuterie
5. Affichage du mode de massage automatique et affichage de la chaleur
6. Affichage de la zone de massage





9. MODE D'EMPLOI

Ce fauteuil de massage peut être pivoté à 360 ° et l'angle entre le dossier et le siège peut être réglé entre 105 ° et 145 °.

Inclinaison

1. Pour incliner le dossier :
 - Assurez-vous que rien ne bloque les côtés et l'arrière de la chaise de massage avant d'incliner le dossier
 - Tirez le levier situé sur le côté de l'accoudoir, puis étirez votre corps contre le dossier afin de déterminer l'angle désiré.
2. Pour remettre le dossier dans sa position d'origine :
 - Tirez le levier vers l'avant pour soulever le fauteuil de massage en position assise. Pour activer les fonctions de massage sur chaise, appuyez légèrement sur les touches du panneau de contrôle.

ACTIVATION/DÉSACTIVATION

Appuyez sur le bouton ACTIVATION (Power ON/OFF) pour activer la fonction de massage. L'indicateur LED s'allume et confirmez votre choix. Pour désactiver les fonctions de massage appuyez simplement sur le bouton à nouveau. Lorsque l'appareil est activé, les fonctions suivantes automatiques sont activées: faible intensité de massage, programme de massage, n°1 et la minuterie de 30 minutes.

INTENSITÉ

Appuyez sur la fonction intensité (INTENSITY) pour choisir l'intensité du massage. Vous pouvez choisir entre dix niveaux d'intensité affichés sur la télécommande.

MINUTERIE

Appuyez sur la touche de minuterie (TIMER) pour sélectionner le temps de massage désiré. Vous pouvez choisir entre 1 à 99 minutes (mode auto est de 30 minutes), lorsque le temps est écoulé, l'action de massage arrête et le voyant DEL s'éteint.

ZONE DE MASSAGE

Gardez ce bouton appuyé (HOLD) pour sélectionner la zone de massage. Les zones de massage sont affichées sur la télécommande.



PROGRAMME

Appuyez sur le bouton "MODE" pour sélectionner votre programme de massage. Il ya dix programmes de massage différents, chacun ayant sa propre personnalité. Le programme choisi est affiché sur la télécommande.

CHALEUR

Appuyez sur cette touche (HEAT) pour activer la fonction de chaleur. Il faut environ 3 minutes pour sentir la chaleur. Appuyez à nouveau pour l'éteindre. Lorsque la température atteint 30-35°C, le chauffage s'arrête automatiquement. Il se remettra automatiquement en marche lorsqu'il aura atteint 20° C.

10. PROTECTION DU PLANCHER

L'utilisation prolongée du fauteuil pourrait abîmer le plancher. Placez l'appareil sur un tapis pour empêcher l'endommagement du plancher.

11. SPÉCIFICATIONS TECHNIQUES

Poids:	25 kg
Puissance:	120 Watts
Voltage:	110 Volts, 60 Hz





12. GARANTIE

GARANTIE LIMITÉE DE UN (1) AN

Ce produit est garanti contre tout vice de matières et de fabrication pour une durée de un (1) an à compter de la date d'achat. En cas de défectuosité, veuillez communiquer avec notre service à la clientèle au 1-866-967-7333. Ayez à portée de la main votre preuve d'achat. Si nous ne sommes pas en mesure de vous remplacer la pièce défectueuse nous vous enverrons un technicien réparateur.

Important : Tout dommage causé à l'une des pièces de produit et attribuable à un accident, une utilisation abusive ou une installation inadéquate n'est **PAS** couvert par la garantie. En vertu de notre politique, nous déclinons toute responsabilité concernant les dommages consécutifs ou indirects. Dans certaines provinces, il est interdit d'exclure ou de limiter les dommages consécutifs ou indirects. Par conséquent, il est possible que l'exclusion ci-dessus ne s'applique pas dans votre cas. La présente garantie vous accorde des droits juridiques spécifiques; vous pouvez également bénéficier d'autres droits, lesquels varient d'une province à l'autre.

SERVICE À LA CLIENTÈLE : 1-866-967-7333



Warranty Registration card

Carte d'enregistrement de garantie



First Name - Prénom		Last Name - Nom	
Address - Adresse		City - Ville	Postal Code - Code Postal
Tel - Tél.		Email - Courriel	

Purchase Date - Date d'achat

Purchased From - Acheté de

Serial Number - Numéro de série

Send to – Expédier à :

EBI
 120 Boul. des Entreprises,
 Boisbriand (Québec) J7G 2T3
 Tél – Tél. : 1-866-967-7333
 Fax – Téléc. : 450-420-2180

Warranty must be active within 30 days of purchase.
La garantie doit être enregistrée dans les 30 jours suivant l'achat.

Date

Signature

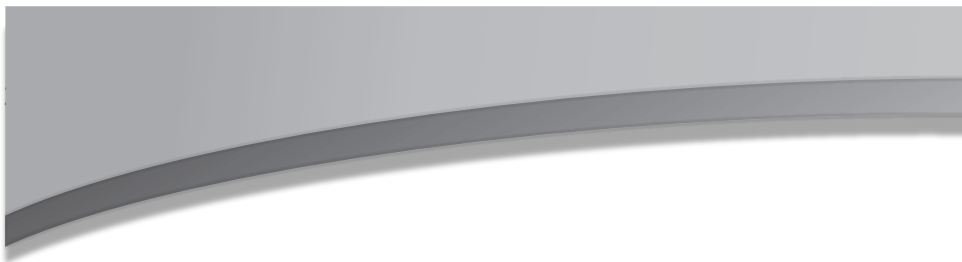

1 866 967.7333

Pictures are for reference only, colors and models may vary without notice. Made in China. iComfort™ is a trademark of EBI Inc. Photographies pour référence seulement. Les couleurs et modèles sont sujet à varier sans préavis. Fabriqué en Chine
iComfortMC est une marque de commerce de EBI inc

www.iComfort.ca

