



WELLS BLOOMFIELD, LLC
2 ERIK CIRCLE, P. O. Box 280 Verdi, NV 89439
telephone: 775-689-5703
fax: 775-689-5976
www.wellsbloomfield.com

162

OPERATION MANUAL for BUILT-IN ELECTRIC CHAR BROILERS



Model B-406



Model B-446

Models:
B-406
B-446
B-506

includes:
INSTALLATION,
USE and CARE

IMPORTANT: DO NOT DISCARD THIS MANUAL

This manual is considered to be part of the appliance and is to be given to the OWNER or MANAGER of the restaurant, or to the person responsible for TRAINING OPERATORS of this appliance. Additional manuals are available from your WELLS DEALER.

THIS MANUAL MUST BE READ AND UNDERSTOOD BY ALL PERSONS USING OR INSTALLING THIS APPLIANCE. Contact your WELLS DEALER if you have any questions concerning installation, operation or maintenance of this equipment.

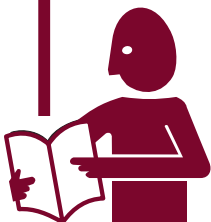

PRINTED IN UNITED STATES OF AMERICA

LIMITED WARRANTY STATEMENT

Unless otherwise specified, all commercial cooking equipment manufactured by WELLS BLOOMFIELD, LLC is warranted against defects in materials and workmanship for a period of one year from the date of original installation or 18 months from the date of shipment from our factory, whichever comes first, and is for the benefit of the original purchaser only.

THIS WARRANTY IS THE COMPLETE AND ONLY WARRANTY, EXPRESSED OR IMPLIED IN LAW OR IN FACT, INCLUDING BUT NOT LIMITED TO, WARRANTIES OF MERCHANTABILITY OR FITNESS FOR ANY PARTICULAR PURPOSE, AND/OR FOR DIRECT, INDIRECT OR CONSEQUENTIAL DAMAGES IN CONNECTION WITH WELLS BLOOMFIELD PRODUCTS.

This warranty is void if it is determined that, upon inspection by an authorized service agency, the equipment has been modified, misused, misapplied, improperly installed, or damaged in transit or by fire, flood or act of God. It also does not apply if the serial nameplate has been removed, or if service is performed by unauthorized personnel. The prices charged by Wells Bloomfield for its products are

based upon the limitations in this warranty. Seller's obligation under this warranty is limited to the repair of defects without charge by a Wells Bloomfield factory authorized service agency or one of its sub-service agencies. This service will be provided on customer's premises for non-portable models. Portable models (a device with a cord and plug) must be taken or shipped to the closest authorized service agency, transportation charges prepaid, for service. In addition to restrictions contained in this warranty, specific limitations are shown in the Service Policy and Procedure Guide. Wells Bloomfield authorized service agencies are located in principal cities. This warranty is valid in the United States and Canada and void elsewhere. Please consult your classified telephone directory, your foodservice equipment dealer or contact:

**Service Department, Wells Bloomfield, LLC
P.O. Box 280, Verdi, Nevada 89439
phone (775) 689-5707 or fax (775) 689-5976**

for information and other details concerning warranty.

SERVICE POLICY AND PROCEDURE GUIDE and ADDITIONAL WARRANTY EXCLUSIONS

1. Resetting of safety thermostats, circuit breakers, over load protectors, and/or fuse replacements are **not** covered by this warranty unless warranted conditions are the cause.
2. All problems due to operation at **voltages or phase other than specified on equipment nameplates** are **not** covered by this warranty. Conversion to correct voltage and/or phase must be the customer's responsibility.
3. All problems due to **electrical connections not made in accordance with electrical code requirements and wiring diagrams** supplied with the equipment are **not** covered by this warranty.
4. Replacement of items **subject to normal wear**, to include such items as knobs, light bulbs; and, normal maintenance functions including adjustments of thermostats, adjustment of micro switches and replacement of fuses and indicating lights are **not** covered by warranty.
5. Damage to electrical cords and/or plug due to exposure to excessive heat are **not** covered by this warranty.
6. Full use, care, and maintenance instructions supplied with each machine. Noted maintenance and preventative maintenance items, such as servicing and cleaning schedules, are customer responsibility. Those miscellaneous adjustments noted are customer responsibility. Proper attention to preventative maintenance and scheduled maintenance procedures will prolong the life of the appliance.
7. Travel mileage is limited to **sixty (60) miles** from an Authorized Service Agency or one of its sub-service agencies.
8. All labor shall be performed during regular working hours. Overtime premium will be charged to the buyer.
9. All genuine Wells replacement parts are warranted for ninety (90) days from date of purchase on non-warranty equipment. This parts warranty is limited only to replacement of the defective part(s). **Any use of non-genuine Wells parts completely voids any warranty.**
10. Installation, labor, and job check-outs are **not** considered warranty and are thus **not** covered by this warranty.
11. Charges incurred by delays, waiting time or operating restrictions that hinder the service technician's ability to perform service are **not** covered by warranty. This includes institutional and correctional facilities.

SHIPPING DAMAGE CLAIM PROCEDURE

NOTE: For your protection, please note that equipment in this shipment was carefully inspected and packaged by skilled personnel before leaving the factory. Upon acceptance of this shipment, the transportation company assumes full responsibility for its safe delivery.

IF SHIPMENT ARRIVES DAMAGED:

1. **VISIBLE LOSS OR DAMAGE:** Be certain that any visible loss or damage is noted on the freight bill or express receipt, and that the note of loss or damage is signed by the delivery person.
2. **FILE CLAIM FOR DAMAGE IMMEDIATELY:** Regardless of the extent of the damage.

3. **CONCEALED LOSS OR DAMAGE:** if damage is unnoticed until the merchandise is unpacked, notify the transportation company or carrier immediately, and file "CONCEALED DAMAGE" claim with them. This should be done within fifteen (15) days from the date the delivery was made to you. Be sure to retain the container for inspection.

Wells Bloomfield cannot assume liability for damage or loss incurred in transit. We will, however, at your request, supply you with the necessary documents to support your claim.

TABLE OF CONTENTS

WARRANTY	xi	Thank you for purchasing this Wells Bloomfield appliance.
SPECIFICATIONS	1	
FEATURES & OPERATING CONTROLS	2	
PRECAUTIONS & GENERAL INFORMATION	4	Proper installation, professional operation and consistent maintenance of this appliance will ensure that it gives you the very best performance and a long, economical service life.
AGENCY LISTING INFORMATION	4	
INSTALLATION	5	
OPERATION	7	
BROILER CHART	9	
TROUBLESHOOTING SUGGESTIONS	10	
CLEANING INSTRUCTIONS	11	
PARTS & SERVICE	13	This manual contains the information needed to properly install this appliance in a manner which will ensure its optimum performance.
CUSTOMER SERVICE DATA	13	

SPECIFICATIONS

MODEL	ELEMENT	VOLTS	KW	AMPS PER LEG 3Ø				AMPS 1Ø	FIELD WIRING
				L1	L2	L3	NEUT .		
B-406	SINGLE ASSEMBLY	208	5.5	12.9	12.9	22.4	N/A	26.0	3Ø 10 ga. 1Ø 8 ga. 90 g
		240	5.5	11.2	11.2	19.4	N/A	22.5	
B-446	SINGLE ASSEMBLY	208	5.5	11.5	22.4	14.4	N/A	26.0	3Ø 10 ga. 1Ø 8 ga. 90 g
		240	5.5	10.0	19.5	12.5	N/A	22.5	
B-506	DUAL ASSEMBLIES	208	11.0	30.0	30.0	30.0	N/A	-	3Ø 8 ga. 1Ø 4 ga. 90g
		240	11.0	26.0	26.0	26.0	N/A	45.0	

NOTE: Refer to appropriate *Installation Instructions* for equipment dimensions, cut-out dimensions, clearances, etc.

FEATURES & OPERATING CONTROLS

ITEM	COMMENT
TEMPERATURE CONTROL	The char-broiler is INFINITE SWITCH CONTROLLED. Power is applied to the heating elements based on the control knob position and the amount of energy used.
INDICATOR LIGHT	Light will glow when the infinite switch is in any position other than <i>OFF</i> .
HEATING ELEMENT ASSEMBLY	The char-broiler element assembly may be raised for cleaning, or to add water to the drip pan. It is held the "up" position by a support rod which automatically engages as the element is raised.
ELEMENT GUARD / GRATE	The grate is designed to protect the individual elements from food contact and spatula abrasion, resulting in prolonged element life and reduced carbonization. The grate is easily removed for cleaning. IMPORTANT: Always remove the grate before lifting the element assembly.
ELEMENT SUPPORT ROD	Hold element assembly in up position. Engages automatically when the element assembly is raised. IMPORTANT: Remember to dis-engage the support rod before lowering element assembly
DRIP PAN	The heavy-duty removable drip pan is located under the element assembly. IMPORTANT: DO NOT pour water over elements to refill drip pan. The drip pan catches food particles and grease drippings during broiler operation. Maintain 2 inches of water in the drip pan at all times during operation of the broiler. The drip pan is easily removed for cleaning.
DATA PLATE	Gives manufacturer, make, model and serial number. Also voltage and phase information, and agency approvals.
WELLSLOKS	The broiler is equipped with WELLSLOKS, uniquely designed turnout tabs, which help secure the broiler to the countertop. (See <i>Installation Instructions</i> supplied with the particular appliance for details.)

FEATURES & OPERATING CONTROLS (continued)

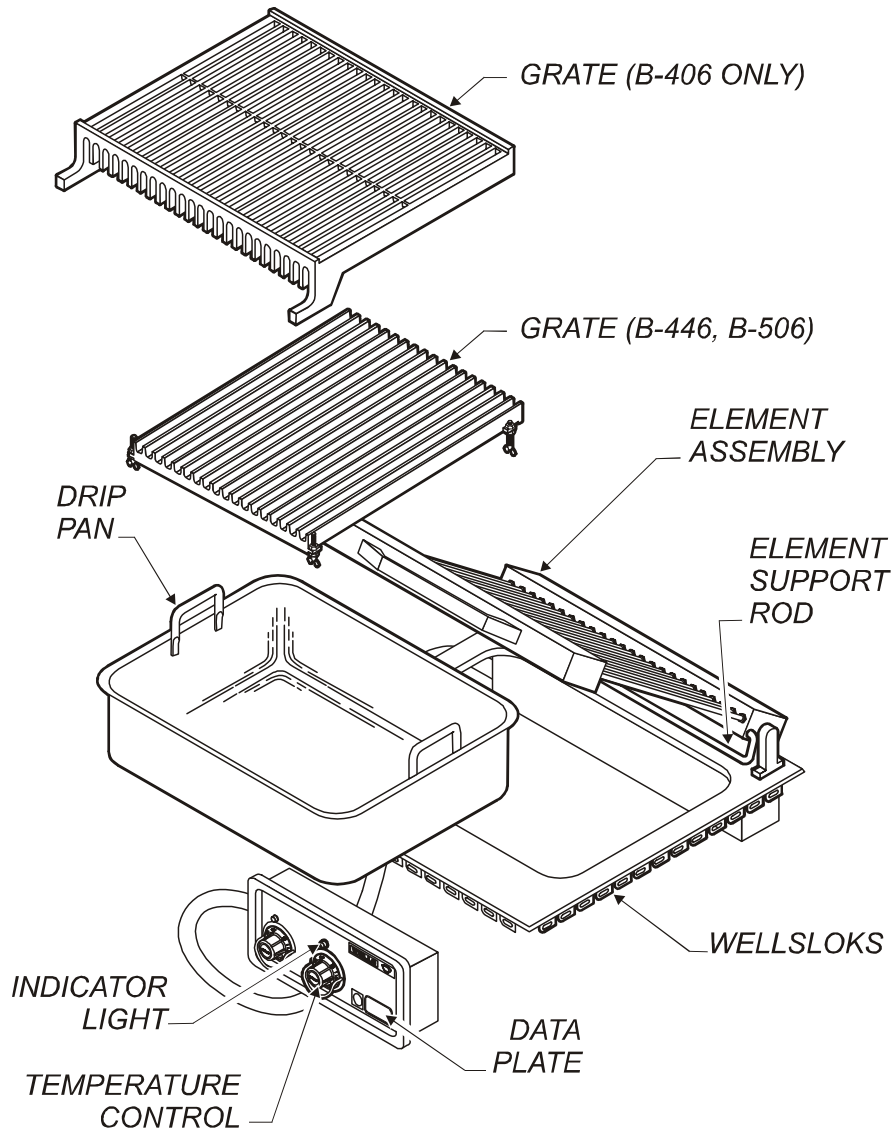

Fig. 1 Built-In Electric Charbroiler

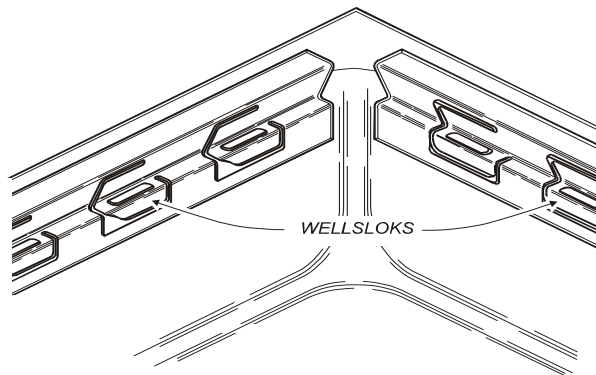

Fig. 2 Wellsloks

PRECAUTIONS AND GENERAL INFORMATION



WARNING: Electric Shock Hazard

All servicing requiring access to non-insulated electrical components must be performed by a factory authorized technician. DO NOT open any access panel which require the use of tools. Failure to follow this warning can result in severe electrical shock.



CAUTION: Risk of Damage

DO NOT connect or energize this appliance until all installation instructions are read and followed. Damage to the appliance will result if these instructions are not followed.

Broilers are intended for use to cook food products for human consumption. No other use is recommended or authorized by the manufacturer or its agents.

Broilers are intended for use in commercial establishments, where all users are familiar with the appliance limitations, use and associated hazards. Operating instruction and warnings must be read and understood by all operators and users.

Do not submerge broilers in water. Do not splash, or pour water onto controls, control panels or wiring.

Disconnect the broiler from electrical power before performing any service or maintenance.

Allow drip pan to cool before removing from broiler. Do not operate broiler without the drip pan installed. Do not operate the broiler without 2" of water in the drip pan.

Any parts replacement, maintenance procedure or servicing procedure requiring the use of tools must be performed by an Authorized Service Agency.

Any troubleshooting guides, component view, parts lists or installation guides provided with this equipment are intended for the use of the qualified technical personnel only.

Except where otherwise noted, this piece of equipment is made in the USA and has American sizes on hardware.

This manual should be considered a permanent part of this appliance. This manual and all supplied instructions, diagrams, schematics, parts break downs, notices and labels must remain with the appliance if it sold or moved to another location.

AGENCY LISTING INFORMATION





STD 4

This appliance conforms to NSF Standard 4 for sanitation only if installed in accordance with the supplied *Installation Instructions*.



E6070

This appliance is Underwriters Laboratory recognized (). Since this appliance is only a single component of a complete installation, the finished installation of this unit  requires additional evaluations to Underwriters Laboratory standards.

Refer to *Installation Instructions* included with the broiler for Underwriters Laboratories conditions of acceptability, electrical

UNPACKING & INSPECTION

Carefully remove the appliance from the carton. Remove all protective plastic film, packing materials and accessories from the appliance before connecting electrical power or otherwise performing any installation procedure.

Carefully read all instructions in this manual and the *Installation Instruction Sheet* packed with the appliance before starting any installation.

Read and understand all labels and diagrams attached to the appliance.

Carefully account for all components and accessories before discarding packing materials. Store all accessories in a convenient place for later use.

CUT-OUT AND INSTALLATION

Cutouts

- Broilers may be installed in METAL COUNTERS ONLY.
- Cutout dimensions for broilers and control panels are listed on the *Installation Instructions* provided with the broiler.
- Refer to the *Installation Instructions* for Underwriters Laboratories *Conditions of Acceptability*.

Mounting the broiler:

- Verify that provided sealants are applied to the under side of the broiler top flange prior to setting the unit into the cutout.
- After installation, verify that the tabs on the Wellsloks are turned out to lock the broiler into the counter (see Fig. 3).
- Apply a thin bead of food-grade silicone sealant around the flange to seal it to the counter.

Refer to the *Installation Instructions* for required clearances. Maintain required clearances between the appliance and adjacent combustible and non-combustible surfaces.

Sufficient overhead clearance must be provided to allow the element assembly to be raised. Refer to the *Installation Instruction Sheet* for required clearances.

Install drip pan and element guard/grate prior to heating or using broiler.

Avoid storing flammable or combustible materials near the appliance. This includes gasoline and other fuels, mops, rags and wrapping paper.

NOTE: DO NOT discard the carton or other packing materials until you have inspected the appliance for hidden damage and tested it for proper operation. Refer to *SHIPPING DAMAGE CLAIM PROCEDURE* on the inside front cover of this manual.

IMPORTANT: This is a GENERAL GUIDE. For specific equipment and cutout dimensions, and other installation details, refer to the *Installation Instructions* supplied with the broilers.

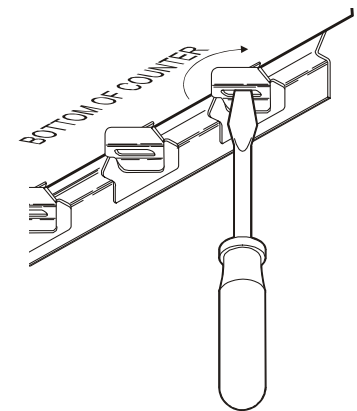

Fig. 3 Set the Wellsloks

IMPORTANT: Water damage caused by failure to set Wellsloks, failure to install gasket, or failure to seal flange to counter is **NOT** covered by warranty.

INSTALLATION (continued)



WARNING:
Risk of personal injury

Installation procedures must be performed by a qualified technician with full knowledge of all applicable electrical codes. Failure can result in personal injury and property damage.



CAUTION:
Electrical Shock Hazard

The broiler must be electrically grounded. Connect the terminal marked "GND" or "⊥" to a suitable building ground.

IMPORTANT: Contact a licensed electrician to install and connect electrical power the broiler.

Electrical installation must be performed by a licensed electrician in compliance with all local ordinances and code requirements.

IMPORTANT: Damage due to being connected to the wrong voltage or phase is **NOT** covered by warranty.

ELECTRICAL HOOK-UP

Refer to the nameplate. Verify the electrical service power. Voltage and phase must match the nameplate specifications. Connecting the griddle to the wrong voltage can severely damage the unit or cause noticeable decreased performance.

Use copper wire suitable for a minimum of 90°C for electrical supply connections.

Broilers are factory wired three-phase (3 ϕ). For single-phase (1 ϕ) wiring, refer to the wiring diagram attached to the broiler. Conversion to 1 ϕ must be performed by a licensed electrician.

This broiler is not fused. Protect the circuit with properly sized fuses or circuit breaker.

An electrical disconnect must be installed readily accessible to the operator of the broiler.

PREPARE THE CHAR-BROILER FOR USE

When using the broiler for the first time, wipe the entire unit with a clean damp cloth or sponge and mild detergent. Rinse thoroughly clean water. Dry with a soft clean cloth.

Remove the GRATE and raise the ELEMENT ASSEMBLY.

Install the DRIP PAN and add 2" (5cm) of tap water.

Release the ELEMENT SUPPORT ROD by lifting the element assembly slightly, then pulling the lower portion of the support rod forward. Lower the ELEMENT ASSEMBLY gently.

MODEL B-406: Grate must be installed ABOVE elements. Install the GRATE, front edge first. The TANGS of the grate go DOWN and point toward the FRONT. The grooves on the underside of the grate align with the elements. The rear edge of the grate can be lowered until it rests firmly on the elements.

MODELS B-446 and B-506: Grate(s) can be installed above or below the elements.
 ABOVE: Gently lower grate over elements. The end with flush tabs goes toward the front.
 BELOW: Install one wing bolt in each tab. The notch in the wing rests on the lip of the drip pan. The end with flush tabs must go toward the front. Adjust the wing bolts so that, when the element assembly is lowered, the top of the element is 1/4" (6mm) below the top of the grate fins.

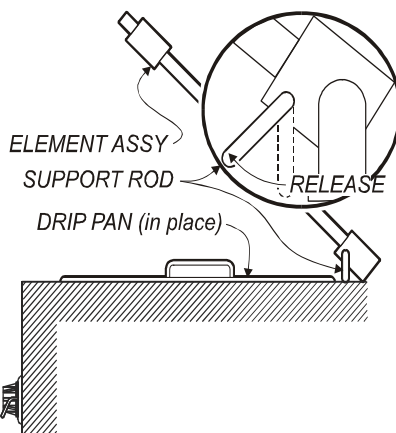

Fig. 4 ELEMENT SUPPORT ROD

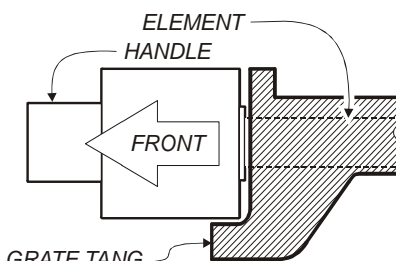

Fig. 5 B-40 GRATE INSTALLATION

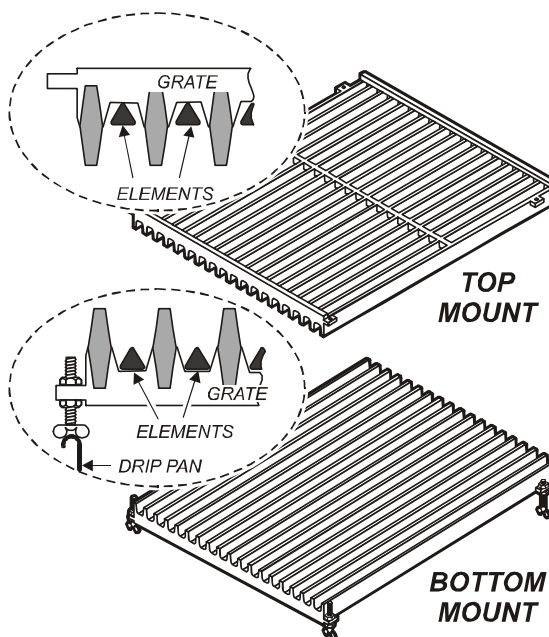

Fig. 6 B-44 and B-50 GRATE INSTALLATION



CAUTION:
Hot Surface

Exposed surfaces can be hot to the touch and may cause burns.

IMPORTANT: DO NOT attempt to raise the element assembly without first removing the grate. Damage to the hinges will result. Such damage is **NOT** covered by warranty.

IMPORTANT: Allow drip pan to cool before removing from the broiler.

DO NOT operate the broiler without the drip pan installed. DO NOT operate the broiler without 2" (5cm) of water in the drip pan.

IMPORTANT: DO NOT attempt to lower the element assembly without first releasing the support rod. Damage to the hinges will result. Such damage is **NOT** covered by warranty.

OPERATION (continued)



CAUTION: Hot Surface

Exposed surfaces can be hot to the touch and may cause burns.

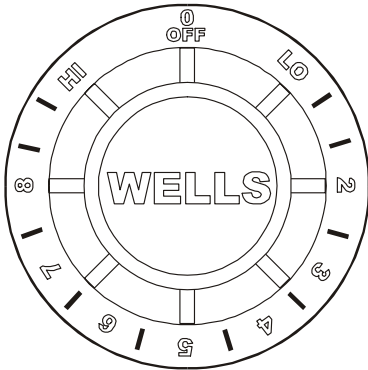

Fig. 7 TEMPERATURE CONTROL

IMPORTANT: DO NOT POUR WATER OVER ELEMENTS TO REFILL PAN.

DO NOT splash or pour water onto controls, control panels or wiring.

TEMPERATURE CONTROLS

Each section of the broiler is equipped with an individual temperature control. The desired temperature is controlled by rotating the TEMPERATURE CONTROL KNOB. Any time the control is turned "ON", the adjacent indicator light will glow. Each section of the broiler may be set to a different temperature setting.

"OFF" removes power from the element., allowing the element to cool. Use *OFF* to turn the broiler off at the end of the cooking day.

"LO" is the lowest temperature settings. Use *LO* for stand-by operation.

"2" thru "8" are temperature settings. Higher number indicate higher temperature.

"HI" is a continuous ON setting. Use *HI* for pre-heating the broiler.

USING THE CHAR-BROILER

Pre-Heat the broiler ten (10) minutes by turning the TEMPERATURE CONTROL to "HI".

After the pre-heat period, turn the TEMPERATURE CONTROL to the desired setting (refer to the Broiler Chart at right for recommended settings).

After every order, use the brush provided to brush any remaining food particles from grate and elements. Keeping the cooking surfaces clean will help in maintaining food taste.

Visually check the water level in the drip pan during operation. Add water as required to maintain 2 inches (5cm) water depth in the drip pan.

**BROILER CHART
RECOMMENDED COOKING TIMES AND DIAL SETTINGS**

NOTE: The times and dial settings in this chart are suggestions only. Your own experience with your own menu items will be your best guide to achieving the best food product.

PRODUCT Condition	THICKNESS	COOKING SETTING	DIAL	TIME Minutes Total
BEEF Frozen	1/2"	Rare	8	4 - 6
"	1/2"	Medium	8	7 - 9
"	3/4"	Rare	7	7 - 9
"	3/4"	Medium	7	8 - 10
"	1"	Rare	7	12 - 14
"	1"	Medium	7	14 - 16
"	1-1/4"	Rare	6	23 - 25
"	1-1/4"	Medium	6	25 - 27
BEEF Non-Frozen	3/4"	Rare	HI	4 - 6
	3/4"	Medium	HI	5 - 7
	1"	Rare	HI	7 - 9
	1	Medium	HI	8 - 10
	1-1/4"	Rare	HI	12 - 14
	1-1/4"	Medium	HI	13 - 15
	1-1/2"	Rare	HI	14 - 16
	1-1/2"	Medium	HI	18 - 20

TROUBLESHOOTING SUGGESTIONS

SYMPTON	POSSIBLE CAUSE	SUGGESTED REMEDY
Won't heat- - no indicator lights	Electric disconnect OFF Circuit breaker tripped	Check / turn disconnect ON Check / reset circuit breaker
One or more section won't heat—or not hot enough	Temperature control not set	Set temperature control knob to desired temperature
	240V unit run on 208V	Verify proper voltage
	Damaged component or wiring	Contact an Authorize Wells Service Agency for repairs
One or more section too hot	Temperature control not set	Set temperature control knob to desired temperature
	208V unit run on 240V	Verify proper voltage
	Damaged component or wiring	Contact an Authorized Wells Service Agency for repairs
Element assy loose, or difficult to raise or lower	Damaged hinge (see page 7 for precautions)	Contact an Authorized Wells Service Agency for repairs
Element assy does not latch in up position	Damaged support rod assembly	Contact an Authorized Wells Service Agency for repairs

NOTE: There are no user serviceable components in this appliance. In all cases of damage or component malfunction, contact your Authorized Wells Service Agency for repairs.

CLEANING INSTRUCTIONS

PREPARATION

Turn both temperature control knobs OFF.
Allow broiler to cool completely.
Disconnect broiler from electric power.

FREQUENCY

Daily.

TOOLS

Steel Brush with Scraper
Plastic Scouring pad, Soft-Bristled Fiber Brush
Mild Detergent, Non-Abrasive Cleanser
Clean Soft Cloth / Sponge

CLEANING

1. Remove the grate from the broiler. Clean grate:
 - a. Use the supplied steel brush with scraper to remove food particles and residue from grate surfaces.
 - b. Grate may be washed in sink or dishwasher.
 - c. Dry the grate and apply a light coating of cooking oil.
2. Raise the element assembly until it latches. Remove and clean the drip pan:
 - a. Stubborn food particles maybe removed with a plastic scouring pad.
 - b. Drip pan may be washed in a sink or dishwasher.
3. Clean the element assembly:
 - a. Use a soft-bristled fiber brush to remove any remaining food particles from the elements.
 - b. Clean the element rods with a soft damp cloth or sponge and mild detergent. Rinse by wiping with a soft cloth moistened with clean water. Dry with a soft cloth.
4. Clean the control panel with a soft damp cloth or sponge and mild detergent. Rinse by wiping with a soft damp cloth moistened with clean water. Dry with a soft cloth.
5. Reassemble broiler:
 - a. Reinstall drip pan.
 - b. Unlatch element support rod and carefully lower the element assembly.
 - c. Reinstall the grate.

Procedure complete.



CAUTION:
Electric Shock
Hazard

Disconnect appliance from electric power before cleaning.



CAUTION:
Burn Hazard

Allow appliance to cool completely before cleaning.



CAUTION:
Electric Shock
Hazard

Do not submerge appliance in water.

IMPORTANT:
DO NOT spill or pour water into controls, control panel or wiring. Damage to internal components will occur. Damage to internal components from water damage is **NOT** covered by warranty.

THIS PAGE BLANK

PARTS & SERVICE

DESCRIPTION	SERVICE PART NO.	
GREASE PAN, B-446 (1 PER UNIT) B-506 (2 PER UNIT)	20174	<p>IMPORTANT: Use only factory authorized service parts and replacement filters. For factory authorized service, or to order factory authorized replacement parts, contact your Wells authorized service agency, or call:</p> <p>Wells Bloomfield, LLC 2 Erik Circle P. O. Box 280 Verdi, NV 89439</p> <p>Service Parts Dept. phone: (775) 689-5707 fax: (775) 689-5976</p> <p>Service Parts Department can supply you with the name and telephone number of the WELLS AUTHORIZED SERVICE AGENCY nearest you.</p>
GREASE PAN, B-406	20202	
GRATE, B-446 (1 PER UNIT) B-506 (2 PER UNIT)	21706	
GRATE, B-406	21707	
BRUSH, BROILER	21708	

CUSTOMER SERVICE DATA

please have this information available if calling for service

RESTAURANT _____	LOCATION _____
INSTALLATION DATE _____	TECHNICIAN _____
SERVICE COMPANY _____	
ADDRESS _____	STATE _____ ZIP _____
TELEPHONE NUMBER (____) _____ - _____	
EQUIPMENT MODEL NO. _____	
EQUIPMENT SERIAL NO. _____	
VOLTAGE: (check one) <input type="checkbox"/> 208 <input type="checkbox"/> 240	



Wells Bloomfield proudly supports CFESA
Commercial Food Equipment Service Association

SERVICE TRAINING - QUALITY SERVICE



CUSTOMER SATISFACTION



WELLS BLOOMFIELD, LLC
2 ERIK CIRCLE, P. O. Box 280 Verdi, NV 89439
telephone: 775-689-5703
fax: 775-689-5976
www.wellsbloomfield.com

PRINTED IN UNITED STATES OF AMERICA