

**VELOX**  
*one*X

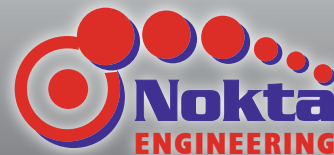

[www.noktaengineering.com](http://www.noktaengineering.com)

**USER MANUAL**

Thank you for choosing and purchasing our Nokta Velox One detector.

Manufacturing high-tech metal detectors since 2001, Nokta Engineering has played a key role in the development of this sector. Nokta Engineering is particularly known for its technological know-how and professional staff.

Seeking to create different kind of technology, Nokta Engineering offers both high-quality products and services to its consumers all around the world. Nokta Engineering has been operating under the principle that environmental and community responsibility, customer satisfaction and insistence on high-quality are of the utmost importance.

Nokta Engineering aims to remain a leading pioneer in its sector, winning the trust of its consumers and always being the preferred choice for metal detecting.



<b>WARNINGS</b> .....	3-4
<b>ASSEMBLY</b> .....	5-8
<b>CORRECT WAY OF HOLDING</b> .....	9
<b>CORRECT WAY OF SWEEPING</b> .....	10
<b>BATTERY</b> .....	11
<b>DEVICE INTRODUCTION</b> .....	12
<b>CONTROLS</b> .....	13-16
<b>TURNING ON THE DEVICE</b> .....	13
<b>GROUND BALANCE</b> .....	13-14
<b>SENSITIVITY</b> .....	14
<b>IRON DISCRIMINATION</b> .....	15
<b>IRON SWITCH</b> .....	15
<b>MINERAL MODES</b> .....	16
<b>SIGNAL AUDIO BOOST</b> .....	16
<b>SEARCHING AND METAL DETECTION</b> .....	17

**WARNINGS!****LEGAL WARNINGS**

▶ When using the device, comply with all applicable laws and regulations. Do not use the device in private premises, historic sites and military zones. Notify the authorities of any historical or cultural findings.

**WARNINGS ABOUT THE DEVICE**

- ▶ This is a high-tech electronic device. Do not assemble or use the device before reading the user manual.
  
- ▶ Do not expose the device or the search coil to very hot or cold conditions for extended periods of time.  
(Storage Temperature: 0°C (32°F) - 40°C (104°F))
  
- ▶ Do not immerse the device or its accessories (except the search coil) in water; do not expose them to extreme humid conditions.
  
- ▶ Protect the device from external impact, especially during transportation.
  
- ▶ The device can only be opened and repaired by authorized service technicians. The warranty will be voided if the device is opened by you or an unauthorized person.

**IMPORTANT**

*Do not use the device indoors. The device will constantly give target signals inside places like homes where there are many metals present. Use the device outdoors, in open fields.*

*Do not let another detector or an electromagnetic device come in close proximity (10m (33ft.)) to the device.*



**IMPORTANT**

*Do not carry any metal objects while using the device. Keep the device away from your shoes while walking. The device may detect the metals on you or inside your shoes as targets.*



*For Consumers within the European Union: Do not dispose of this equipment in general household waste. The crossed wheeled bin symbol on this equipment indicates this unit should not be disposed of in general household waste, but recycled in compliance with local government regulations and environmental requirements.*



*This device complies with Part 15 of the FCC Rules. Operation is subject to the following two conditions: (1) this device may not cause harmful interference, and (2) this device must accept any interference received, including interference that may cause undesired operation.*



- 1) System Box
- 2) Handle and S-Rod
- 3) Search Coil
- 4) Search Coil Cover
- 5) Upper Shaft
- 6) Extension Shaft
- 7) Wingnut, Fastening Screw and Washers
- 8) 8 AA Batteries
- 9) Battery Case
- 10) Battery Case Cover
- 11) Headphones



Coil cover use is optional. It protects the search coil from scratches. If you want to use the cover, attach the cover to the coil and press firmly on the edges to secure.

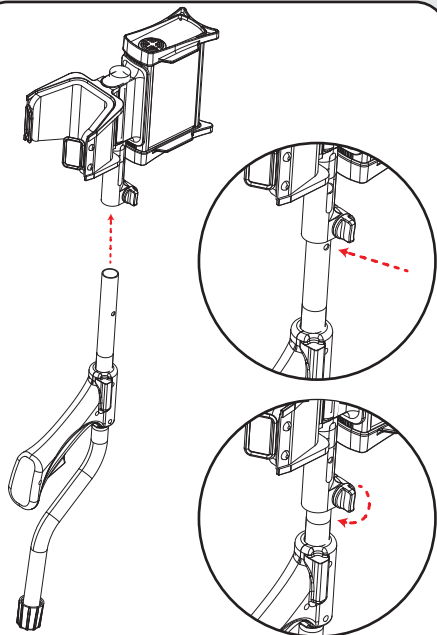

Holding the metal pin pressed, insert the S-rod into its place underneath the system box and secure it by tightening the wingnut as shown in the picture.

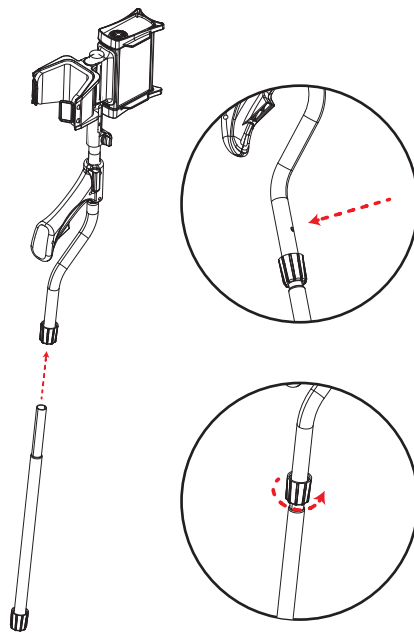

Again by holding the metal pin pressed, insert the upper shaft into the S-rod and click the pin into its hole. Then, secure it by tightening the twist lock.

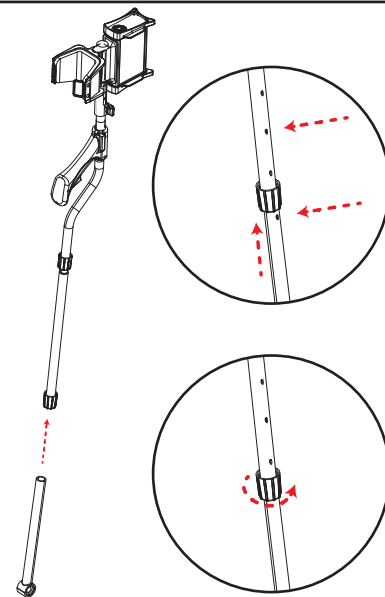

Insert the extension shaft into the upper shaft holding the metal pin pressed and adjust the height by clicking the pin into one of the holes. Then, secure it by tightening the twist lock again.

## ASSEMBLY

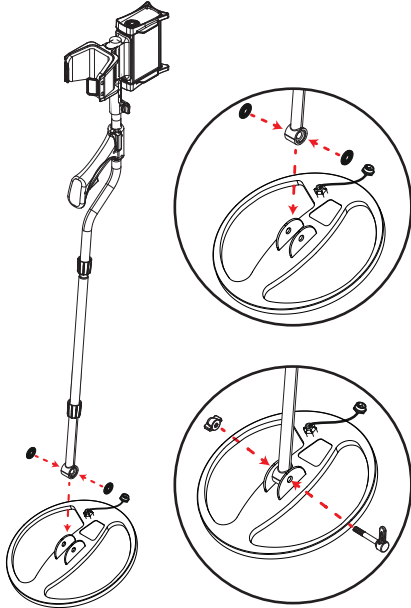

Place the washers into the openings on both sides at the end of the extension shaft. After placing the shaft on the coil as shown in the picture, insert the fastening screw through the hole and tighten it using the wingnut.

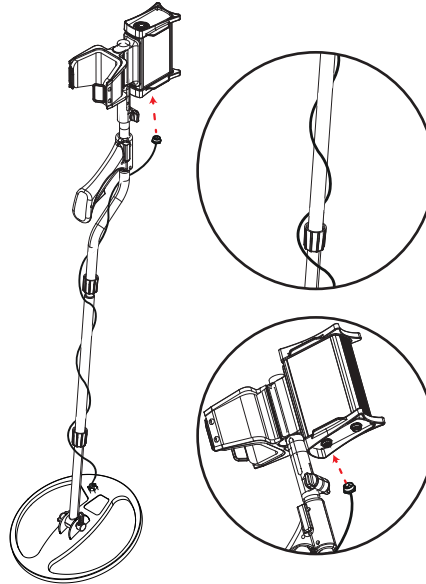

Wrap the coil cable around the shaft all the way up as shown in the picture and after inserting it in the coil input socket underneath the system box, secure it by twisting the connector. Pay attention to not wrap the cable too tight during this step.



**To carry the battery case on your waistband:** Insert the battery case in the leather cover. As shown in the picture, attach the clip to the backside of your belt. Plug the battery case cable into the socket underneath the system box and tighten securely.



1



2



3a



3b



4



5



To attach the battery case to the system box: Follow the above steps in the pictures. After step 5, plug the battery case cable into the socket underneath the system box and tighten securely.



Assembly is completed.

## CORRECT WAY OF HOLDING



Shaft height is wrong.

It is very important to adjust the shaft to your height correctly to be able to search without discomfort and fatigue.

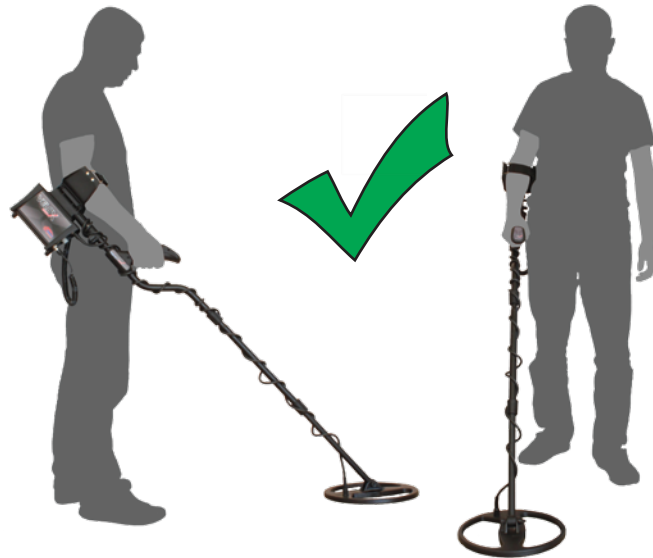

Shaft height is correct.

Adjust the height of the shaft so that you are standing in an upright position, your arm is relaxed and the search coil is approximately 5cm (~2") above the ground.

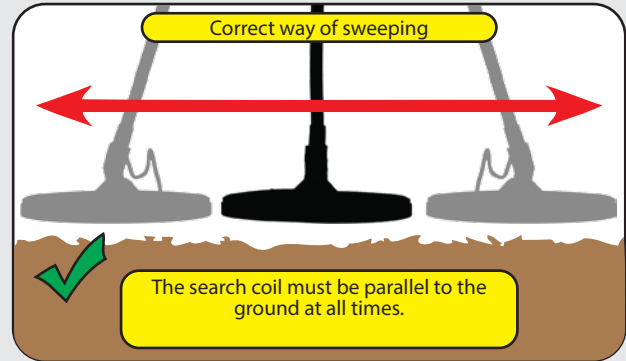
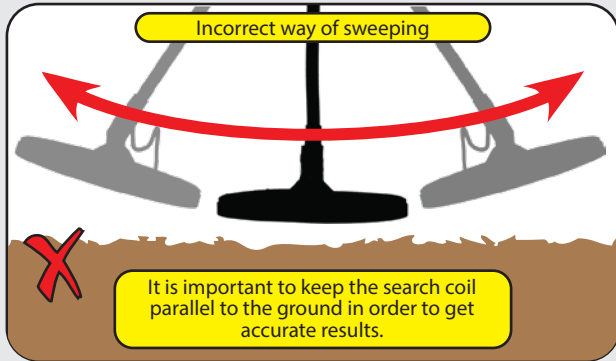
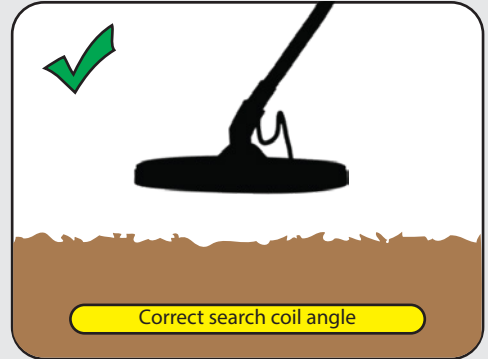
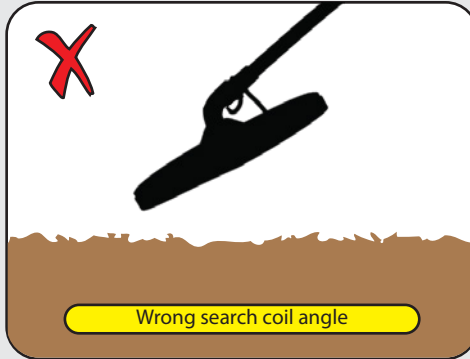
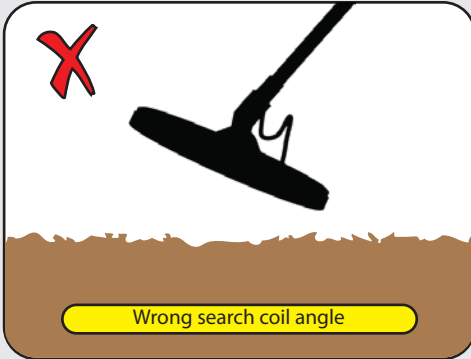

## BATTERY



The device comes with 8 AA Alkaline batteries and a battery case. Insert the batteries in the case paying attention to the + (plus) and - (minus) poles. When batteries are full, they will provide approximately 25-30 hours of use. Different types or brand of batteries may have different lifetimes.

**LOW BATTERY:** When the batteries are low, the device will produce a warning sound approximately once every minute. The device will shut down automatically 3-4 hours after the warning.



Optional

Optional

Those who prefer rechargeable batteries can purchase the optional lithium polymer battery and search over 50 hours.

You may also purchase the optional car charger with the lithium polymer battery and charge your battery on-the-go as well.



Optional

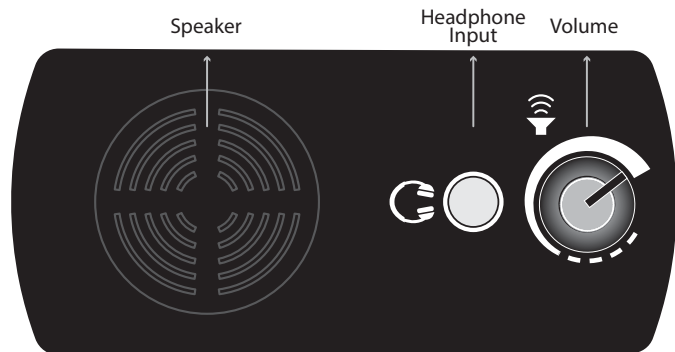
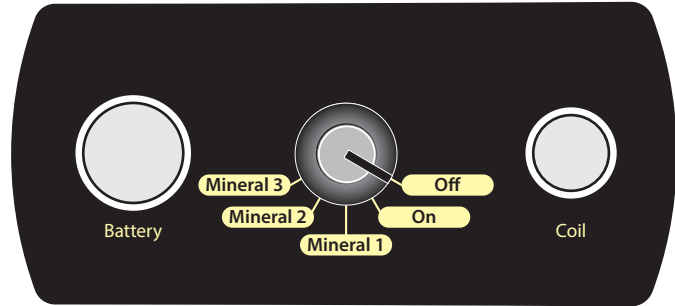

### TURNING ON THE DEVICE

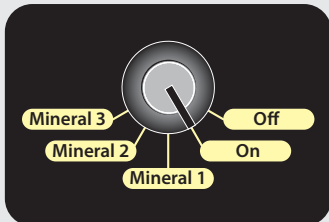

To turn on the device, rotate the On/Off knob to ON. Turn the same knob to OFF position when you want to turn off the device. When the device is turned on, a melody will be heard and approximately 10 seconds later you will hear a long beep indicating that the device is ready to use.

The device will provide more depth at on position. However, to better discriminate ferrous metals, using the device in mineral modes and the iron discrimination at maximum position is recommended.

### GROUND BALANCE

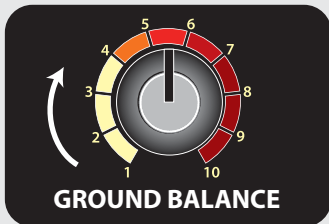

Especially in mineralized ground target signal is negatively affected by the "noise" caused by ground mineralization. This situation may prevent the detector from getting a clean signal from the target necessary for metal detection and accurate discrimination. Ground balancing is a process through which the metal detector is able to cancel out the negative effects caused by ground mineralization.

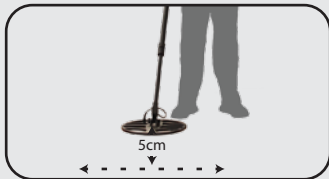

To ground balance, holding the search coil 5cm. above the ground, sweep it right and left, keeping it parallel to the ground and slowly turn the ground balance knob clockwise until the noise is gone and the device is silent. If you cannot ground balance the detector, gradually decrease the sensitivity and repeat the above steps.

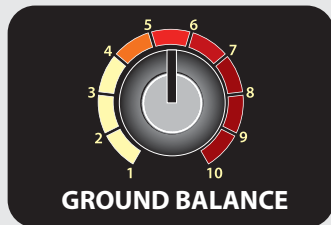

For maximum depth, do not turn the ground balance knob to the right more than necessary. Generally speaking, the mid-level (between 4-7) offers the most ideal and stable detection capability on different types of ground without sacrificing depth.

As the ground balance goes into the right area, the device will start losing depth for some non-ferrous metals except for gold. When the ground balance setting reaches the maximum point the device will detect iron and gold but it will not detect some non-ferrous metals.

If you are searching on a ground loaded with mineralized stones or dips and holes, it is recommended to ground balance over one of these stones or the holes.

In areas of very high mineralization, ground balance may not be sufficient. In such a case, you may need to use the mineral search modes (see page 16).

## SENSITIVITY

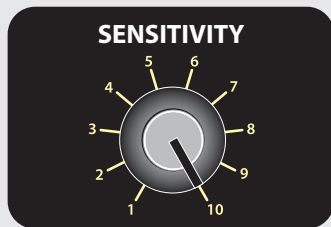

Sensitivity setting is used to eliminate interferences caused by electromagnetic waves in the surrounding environment or ground noise. Electromagnetic waves may result from power lines in the surrounding environment or from the operation of electrical devices, radars, wireless radios, and even TVs.

Sensitivity is also the depth setting for the device. Therefore, especially in high mineralization, it is recommended that you lower it only if the device is still getting noise after you adjust all the other settings (ground balance, iron discrimination and mineral modes).

### IRON DISCRIMINATION



This setting is designed for tough ground conditions and experienced users. For normal ground conditions or if you do not want to bother with this setting it is recommended that you keep it at the factory setting (FS).

This setting has 2 main purposes:

1) Especially in areas of high iron mineralization and wet beach sand you may not be able to ground balance the device. In such a case, you can use iron discrimination. By turning the iron discrimination knob to the right, you can enable the ground effect to be reflected as iron and eliminate it by turning the iron switch off.

In general, when searching in wet salt water beach sand, the most ideal settings are the maximum level of the iron discrimination, iron switch off and mineral 2 or 3 modes. You can also use these settings when searching in wet plowed land with high iron effect.

2) It enables metals containing iron to produce a low tone and to be discriminated more easily. Discrimination starts at about level 4 - 6. Below this level, all metals including iron will produce a non-ferrous (high) tone and generally speaking the device will perform at its maximum depth. In addition, iron switch will not be active below this level.

### IRON SWITCH

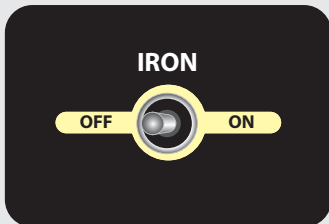

When you want to avoid detecting ferrous metals you can turn the iron switch off and enable the device to eliminate these metals and not produce a warning tone.

**NOTE:** Many metals considered to be trash may not produce a ferrous metal signal. For example, pull tabs may be sensed as a non-ferrous metal by most detectors because their signal is very similar to that of gold.



## MINERAL MODES

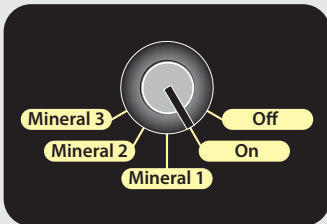

**Mineral Modes:** If you are searching on high mineralized ground (extremely salty soil, wet beach sand, wet plowed land or highly magnetic ground conditions) you may not be able to ground balance the device. In such a case, first turn the On/Off knob to mineral 1. If the device is still getting noise, turn it to mineral 2 or mineral 3. This will eliminate the noise and false signals caused by mineralization. However, you may experience a decrease or fading in the signal obtained from certain metals at maximum depths.

As mentioned before, especially on grounds with high iron content such as wet salt water beach sand and wet plowed land, it is recommended that you search in mineral 2 or 3 mode, bring the iron discrimination to maximum level and turn the iron switch off.

## SIGNAL AUDIO BOOST



The signal audio boost switch boosts the sound of weak signals received from small or deep metals making it easier for you to detect those uncertain targets.

At position 1, the booster is off. At 2, the signal audio will be higher and at 3, it will be heard at its maximum.

Please note that signal audio boost should be used on a temporary or as-needed basis because it will not only boost the target signal audio but it will also boost the loudness of ground noise and false signals. Therefore, it is recommended to keep the switch at position 1 and turn it to position 2 or 3 only when you want to verify a weak metal signal and then turn it off again.

### SEARCHING AND METAL DETECTION

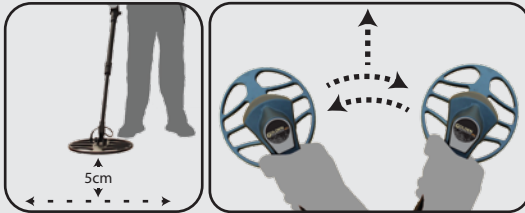

After the settings are adjusted, you can start searching by lifting the search coil 5cm. above the ground and sweeping it right and left, keeping it parallel to the ground.

The device operates on the principle of motion. This means that you must move the search coil over the target or the target over the search coil, in order for the device to see it. In other words, metal detection is not possible without moving the search coil.

To avoid missing smaller and deeper targets, sweep the search coil both from right to left and left to right over each area you are scanning, slightly overlapping the sweeps as you move forward.

When the device detects metal, it will produce an audible tone.

The device has 3 tone audio discrimination. The lower tone is for ferrous metals. For non-ferrous metals and gold, the device produces 2 very similar high tones. In case of alloy detection the device may produce a high-low double-tone sound. In order to get familiar with the different tones of your device, it is recommended that you practice with different types of metals and identify the sounds before you use it out in the field.

**NOTE:** Discrimination, just like in any other metal detector, may not always be 100% accurate. There are many different factors affecting discrimination accuracy. All metals based on their conductivity, shape, orientation underground, depth and ground mineralization are sensed differently by a detector. Oxidized metals buried under ground for a long time such as tinplates and tins may produce gold like signals.

Following the experienced metal detector users' rule of thumb "when in doubt, dig" is the right thing to do.

**Operating Principle:** Induction Balance

**Operating Frequency:** 17.5 KHz

**Metal Identification:** Audio warning

**Audio Discrimination:** 3 tones

**Sensitivity Setting:** Manual

**Ground Balance:** Manual

**Search Coil:** 28cm (11") waterproof Double-D

**Battery:** 8 x AA Alkaline Batteries

**Headphone Output:** 1/4" mono

**Length:** 125-145cm (49"-57") extendable

**Weight:** 2.0kg (4.4lbs) including the search coil

**Warranty:** 2 years

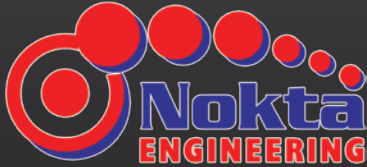

Emek Mah. Sivatyolu Cad. Sakiz Sok. No: 4  
34785 Sancaktepe - Istanbul / Turkey  
Phone : +90 216 415 56 86  
Fax : +90 216 415 63 43  
E-mail: [info@noktaengineering.com](mailto:info@noktaengineering.com)

