



Fasteners

The fasteners listed in this manual are available at extra cost from your local dealer or Black & Decker Service Center.

A complete listing of service centers is included on the owner's registration card packed with your tool.

If you need assistance in locating any accessory please contact: Black & Decker (U.S.) Inc., User Services Department, 10 North Park Drive, P.O. Box 857, Hunt Valley, MD 21030-0857.

(CAUTION: The use of any other fastener or attachment might be hazardous.)

Important

To assure product SAFETY and RELIABILITY, repairs, maintenance and adjustment should be performed by Black and Decker Service Centers or other qualified service organizations, always using Black & Decker replacement parts.

Commercial/Industry Use Warranty (One Year)

Black & Decker (U.S.) Inc. warrants this product for one year against any defects that are due to faulty material or workmanship. Please return the complete unit, transportation prepaid, to the seller (if a participating retailer) for free replacement (proof of purchase may be required). The unit may also be returned to a Black & Decker Service Center or Authorized Service Station, listed under "Tools Electric" in the Yellow Pages for free replacement or repair at our option. This warranty does not apply to accessories. This warranty gives you specific legal rights and you may have other rights which may vary from state to state. Should you have any questions, contact your nearest Black & Decker Center Manager.

Like most Black & Decker tools, this tool is listed by Underwriters' Laboratories to ensure that it meets stringent safety requirements.

This symbol on the name plate means the product is listed by Underwriters' Laboratories, Inc.

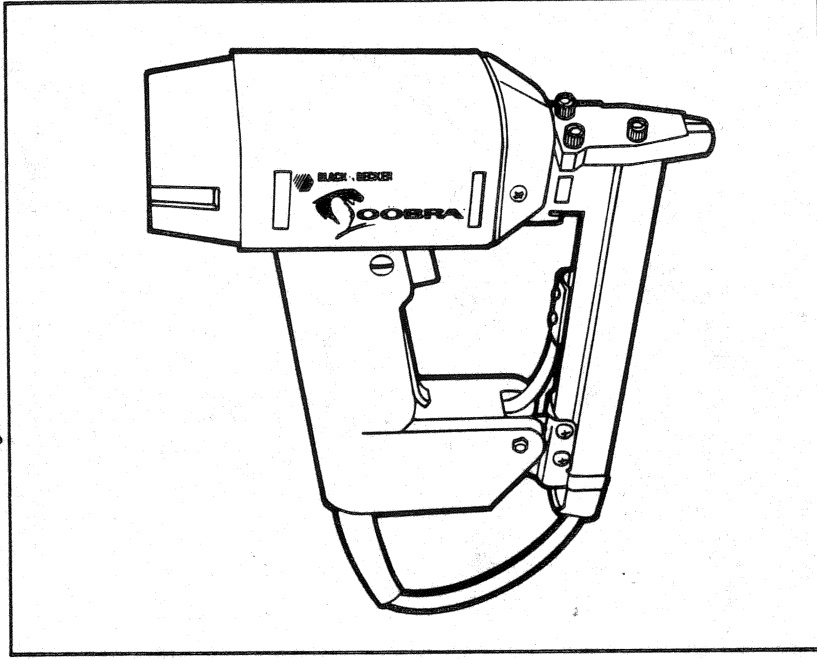

Instruction Manual

Electric Stapler

READ THESE INSTRUCTIONS AND WARNINGS
BEFORE OPERATING THE UNIT.

120 VOLT 50/60 HZ ONLY.



Distributed by
Black & Decker (U.S.) Inc., 10 North Park Drive, P.O. Box 798, Hunt Valley, MD 21030-0798

Form No. 313979
©1987 Printed in U.S.A.
(NOV87)

WARNING: To avoid serious eye injury, eye protection equipment conforming to the requirements of ANSI-Z87-1 and OSHA regulations **MUST** be worn by the tool operator and everyone in the vicinity of the tool.
Safety glasses conforming to those requirements have been supplied with this tool.

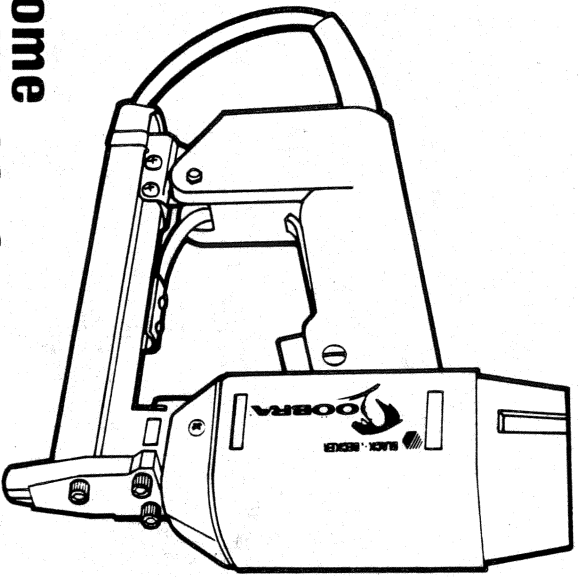

Welcome to the World of Black & Decker Power Tools.

Your new Electric Stapler is the perfect tool to make repetitive, heavy duty stapling jobs easy and fast.

For personal safety and for proper operation of your Stapler, please take the time to carefully

read all of the safety rules and instructions in this booklet. Don't forget to send in the owner registration card.

THANK YOU for buying BLACK and DECKER!

BLACK & DECKER.



Fastener Jamming

When tested at the factory, this tool was as jam-proof as can be; however, damage to parts or excessive accumulation of dirt can lead to improper operation of the tool. If a jam should occur, disconnect the line cord, slide the magazine back and remove staples. This quick-clear feature separates the front and rear nose sections so the jammed fastener can be easily removed. If the tool is clean and jamming continues, contact your B&D representative for additional help.

Plunger Assembly

See Figures 4 and 5
The Driver Blade and the Return Bumper are subject to normal wear and periodically must be serviced.

To remove the Plunger Assembly, remove the Service Cap as shown in Figure 4. The Plunger Assembly may be slipped straight out.

To replace the Driver Blade:

1. Use a small drill punch to tap out the Roll Pin that retains the Blade to the Plunger.
2. Insert a new Blade and replace the Roll Pin.

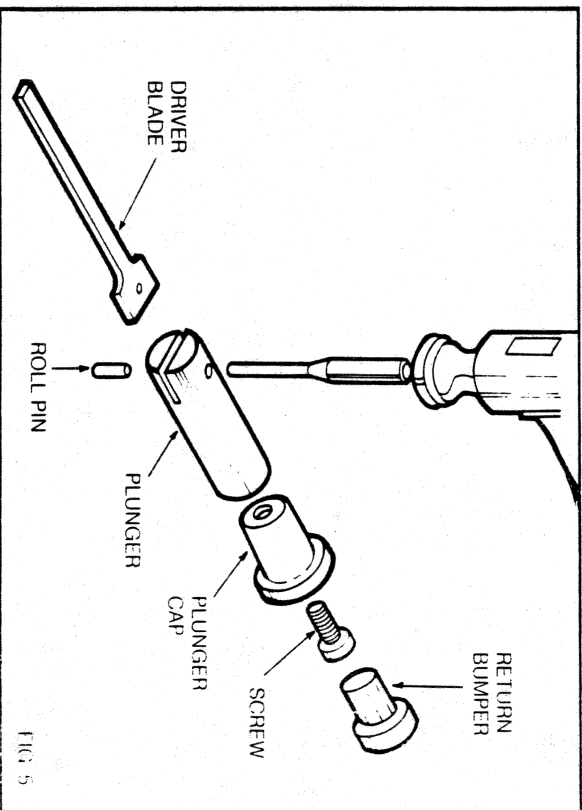

FIG. 5

CAUTION: Make sure the Roll Pin is below the outside diameter of the Plunger. Any portion of the Pin protruding past the Plunger diameter would cause damage to the electric coil.

1. Pull the old Bumper out of the Plunger Cap.
2. Slightly moisten the fluted end of the new Bumper with water and push in until it is fully seated in the Cap.

CAUTION: One or two drops of water is sufficient to moisten. **DO NOT** use any other type of lubricant. **WHEN REPLACING ANY PART ON THIS TOOL—USE ONLY IDENTICAL BLACK & DECKER REPLACEMENT PARTS.**

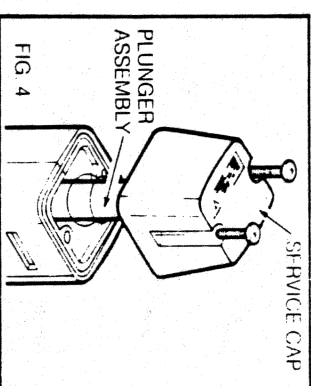

FIG. 4

SAFETY INSTRUCTIONS

WARNING: When using Electric Tools, basic safety precautions should always be followed to reduce the risk of fire, electric shock, and personal injury, including the following:

READ ALL INSTRUCTIONS

1. **KEEP WORK AREA CLEAN.** Cluttered areas and benches invite injuries.
2. **CONSIDER WORK AREA ENVIRONMENT.** Don't expose power tools to rain. Don't use power tools in damp or wet locations. Keep work area well lit. Do not use tool in presence of flammable liquids or gases.
3. **GUARD AGAINST ELECTRIC SHOCK.** Prevent body contact with grounded surfaces, for example, pipes, radiators, refrigerator enclosures.
4. **KEEP CHILDREN AWAY.** Do not let visitors contact tool or extension cord. All visitors should be kept away from work area.
5. **STORE IDLE TOOLS.** When not in use, tools should be stored in dry, and high or locked-up place — out of reach of children.
6. **DON'T FORCE TOOL.** It will do the job better and safer at the rate for which it was intended.
7. **USE RIGHT TOOL.** Don't force small tool or attachment to do the job of a heavy-duty tool. Don't use tool for purpose not intended—for example—don't use circular saw for cutting free limbs or logs.
8. **DRESS PROPERLY.** Do not wear loose clothing or jewelry. They can be caught in moving parts. Rubber gloves and nonskid footwear are recommended when working outdoors. Wear protective hair covering to contain long hair.
9. **USE SAFETY GLASSES.** Also use face or dust mask if cutting operation is dusty.
10. **DON'T ABUSE CORD.** Never carry tool by cord or yank it to disconnect from receptacle. Keep cord from heat, oil, and sharp edges.
11. **SECURE WORK.** Use clamps or a vise to hold work. It's safer than using your hand and it frees both hands to operate tool.
12. **DON'T OVERREACH.** Keep proper footing and balance at all times.
13. **MAINTAIN TOOLS WITH CARE.** Keep tools sharp and clean for better and safe performance. Follow instructions for lubricating and changing accessories. Inspect tool cords periodically and, if damaged, have repaired by authorized service facility. Inspect extension cords periodically and replace if damaged. Keep handles dry, clean and free from oil and grease.
14. **DISCONNECT TOOLS.** When not in use, before servicing, and when changing accessories, such as blades, bits, cutters.
15. **REMOVE ADJUSTING KEYS AND WRENCHES.** Form habit of checking to see that keys and adjusting wrenches are removed from tool before turning it on.
16. **AVOID UNINTENTIONAL STARTING.** Don't carry plugged-in tool with finger on switch. Be sure switch is off when plugging in.
17. **OUTDOOR USE EXTENSION CORDS.** When tool is used outdoors, use only UL approved extension cords intended for use outdoors and so marked.
18. **STAY ALERT.** Watch what you are doing. Use common sense. Do not operate tool when you are tired.
19. **CHECK DAMAGED PARTS.** Before further use of the tool, a guard or other part that is damaged should be carefully checked to determine that it will operate properly and perform its intended function. Check for alignment of moving parts, binding of moving parts, breakage of parts, mounting, and any other conditions that may affect its operation. A guard or other part that is damaged should be properly repaired or replaced by an authorized service center unless otherwise indicated elsewhere in this instruction manual.
20. **USE ONLY BLACK & DECKER COBRA™.** Use only fasteners manufactured or recommended by Black & Decker Cobra™.
21. **CHECK SAFETIES.** Before using the tool, check to see that the safeties are in proper operating condition and the equipment functions properly.
22. **FOR MAXIMUM SAFETY.** Disconnect the tool from power source when: 1) Loading or unloading the tool. 2) The equipment is left unattended. 3) Maintenance or repairs are to be performed on it. 4) Clearing a jam. 5) Moving to another location.
23. **DO NOT TAMPER WITH TOOL.** Do not remove, tamper with, or otherwise cause the safety yoke to become inoperative.
24. **NEVER POINT TOOL.** Never point the tool toward yourself or anyone else, whether it contains fasteners or not.

— SAVE THESE SAFETY RULES FOR FUTURE USE. —

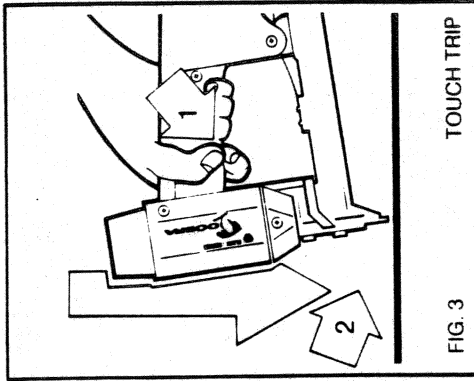

FIG. 3 TOUCH TRIP

Maintenance & Repairs

The following maintenance and repairs can be performed by the operator. Any further maintenance or repairs must be done by a Black & Decker authorized service representative. Warranty is voided if owner-operator elects to perform maintenance or repairs beyond that which is specified herein.

Cleaning & Lubrication

External cleaning may be done as follows:

- a. Disconnect the tool at power source.
 - b. Open the magazine and remove all fasteners.
 - c. Using compressed air or a brush remove all grit and dirt from the magazine and the nose of the tool.
- DO NOT LUBRICATE**—One of the features of this tool is that it does not require any oil or grease.

Operation cont'd

OPERATING METHODS

There are two standard methods of driving staples:

1. **TRIGGER OPERATION** (See Fig. 2) Trigger operation method is the most commonly used. This method assures accurate placement of the staple and the maximum drive power.
 - Depress power switch.
 - Position the front nose at the point where the staple is to be driven (depressing the triggering yoke).
 - Hold the tool firmly against the material to be fastened and pull the trigger.

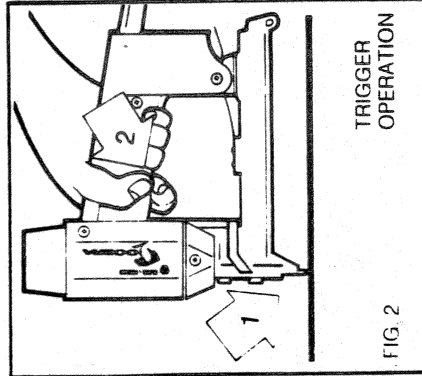

FIG. 2 TRIGGER OPERATION

2. **YOKE OPERATION (TOUCH TRIP)** (See Fig. 3) The Touch Trip method can be used when more speed and less accuracy and drive power are required.
 - Depress power switch.
 - Pull the trigger.
 - With the trigger depressed, strike the nose against the work surface, thus depressing the safety yoke.

WARNING: Do not operate the tool without fasteners.

Grounding

In the event of a malfunction or breakdown, grounding provides a path of least resistance for electric shock. This tool is equipped with an electric cord having an equipment-grounding conductor and a grounding plug. The plug must be plugged into a matching outlet that is properly installed and grounded in accordance with all local codes and ordinances.

Do not modify the plug provided if it will not fit the outlet; have the proper outlet installed by a qualified electrician.

Improper connection of the equipment-grounding conductor can result in a risk of electric shock. The conductor with insulation having an outer surface that is green with or without yellow stripes is the equipment-grounding conductor. If repair or replacement is necessary, do not connect the equipment-grounding conductor to a live terminal.

Check with a qualified electrician or serviceman if the grounding instructions are not completely understood, or if in doubt as to whether the tool is properly grounded.

Use only UL approved 3-wire extension cords that have a 3-prong grounding plug and 3-pole receptacle that accepts the tool's plug.

Repair or replace a damaged or worn cord immediately.

This tool is intended for use on a circuit that has an outlet that looks like the one illustrated in Fig. A. The tool has a grounding plug that looks like the plug illustrated in Fig. A. A temporary adapter, which looks like the adapter illustrated in Fig. B may be used to connect this plug to a 2-pole receptacle as shown in Fig. C if a properly grounded outlet is not available.

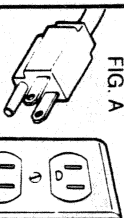

FIG. A



FIG. B

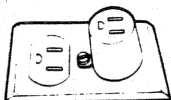

FIG. C

WARNING: To avoid serious eye injury, eye protection equipment conforming to the requirements of ANSI Z87-1 and OSHA regulations **MUST** be worn by the tool operator and everyone in the vicinity of the tool. Safety glasses conforming to those requirements have been supplied with this tool.

The temporary adapter should be used only until a properly grounded outlet can be installed by a qualified electrician. The green colored rigid ear, lug, etc. extending from the adapter must be connected to a permanent ground such as properly grounded outlet box.

Use With Generator

This product may be used with a 50/60 Hz generator with a minimum output of 1500 watts. The use of one of less power will cause reduced performance and may damage the unit. This unit will not operate from a DC generator.

Extension Cords

Tools that have 3-wire cords requiring grounding must only be used with extension cords that have 3-prong grounding type plugs and 3-pole receptacles. Only round jacketed extension cords should be used, and we recommend that they be listed by Underwriters Laboratories (UL). If the extension will be used outside, the cord must be suitable for outdoor use. Any cord marked as outdoor (The letters "WA" on the cord jacket indicate a cord recommended for outdoor use) can also be used for indoor work.

An extension cord must have adequate wire size (AWG or American Wire Gauge) for safety, and to prevent loss of power and overheating. The smaller the gauge number of the wire, the greater the capacity of the cable, that is 16 gauge has more capacity than 18 gauge. When using more than one

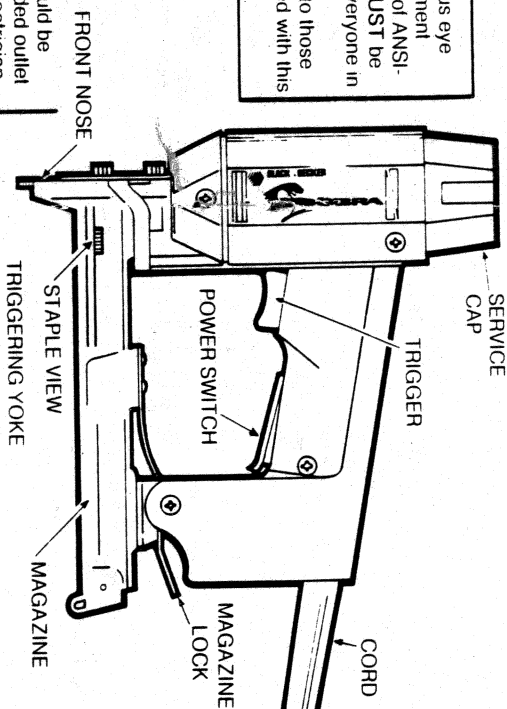

extension cord to make up the total length be sure each individual extension cord contains at least the minimum wire size. MINIMUM WIRE GAUGE REQUIREMENTS FOR THIS STAPLER: TO 25 FT. - 14 GA. TO 50 FT. - 10 GA.

Before using an extension cord, inspect it for loose or exposed wires, damaged insulation and defective fittings. Make any needed repairs or replace the cord if necessary. Black & Decker has extension cords available that are UL listed for outdoor use.

Connect the power cord to the extension cord as shown below.



EXTENSION POWER CORD
EXTENSION CORD

Operation

CAUTION: ALWAYS WEAR EYE PROTECTION!
LOADING FASTENERS OR CHANGING STAPLES.

With the tool inverted and the power switch released, compress the magazine

cover lock at the back of the tool and pull the magazine cover back. Insert the fasteners into the magazine. Push magazine cover forward into a locked position. See Fig. 1

This tool is equipped with a power switch, a trigger, and a triggering yoke. All of them must be activated before the tool will operate.

1. The power switch is located in the rear portion of the handle and must be squeezed tight.
2. The triggering yoke is located in the nose and must be pushed up into the nose when the tool is pushed against the work surface.
3. The trigger is located in the front portion of the handle and must be pulled tight.

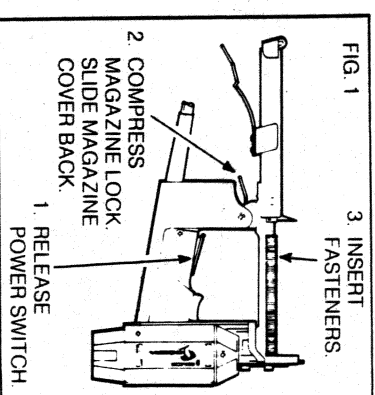

STAPLE SELECTION

1000 STAPLES		5000 STAPLES	
	9702	9702	9707
97-050	1/4	XXX	XXX
97-051	5/16	XXX	XXX
97-052	3/8	XXX	XXX
97-053	1/2	XXX	XXX
97-054	9/16	XXX	XXX
97-055	1/4	XXX	XXX
97-056	5/16	XXX	XXX
97-057	3/8	XXX	XXX
97-058	1/2	XXX	XXX
97-059	9/16	XXX	XXX
97-065	3/8	XXX	XXX
97-066	9/16	XXX	XXX