



Instruction Manual

3680 12" Compound Miter Saw

Getting the most out of your tool.

Please take time to read this manual and pay particular attention to the safety rules we've provided for your protection. Don't forget to send in your owner's registration card. If you have any questions about your tool please call:

1-800-9-BD TOOL

(1-800-923-8665)

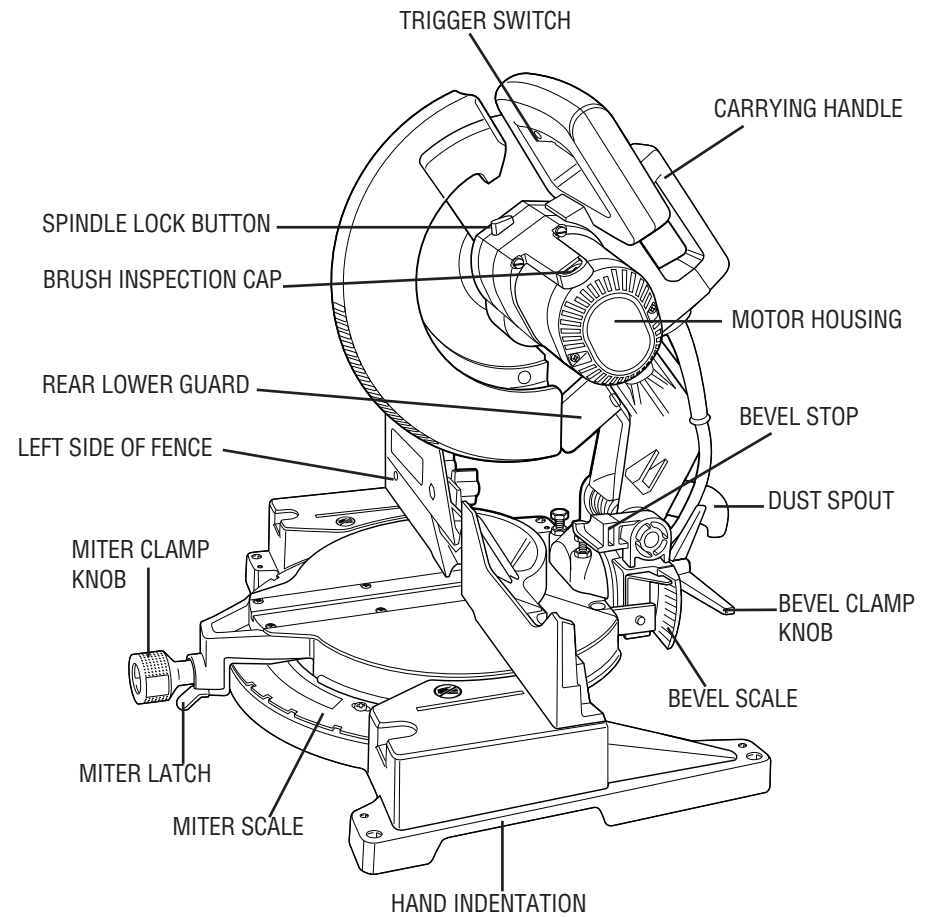
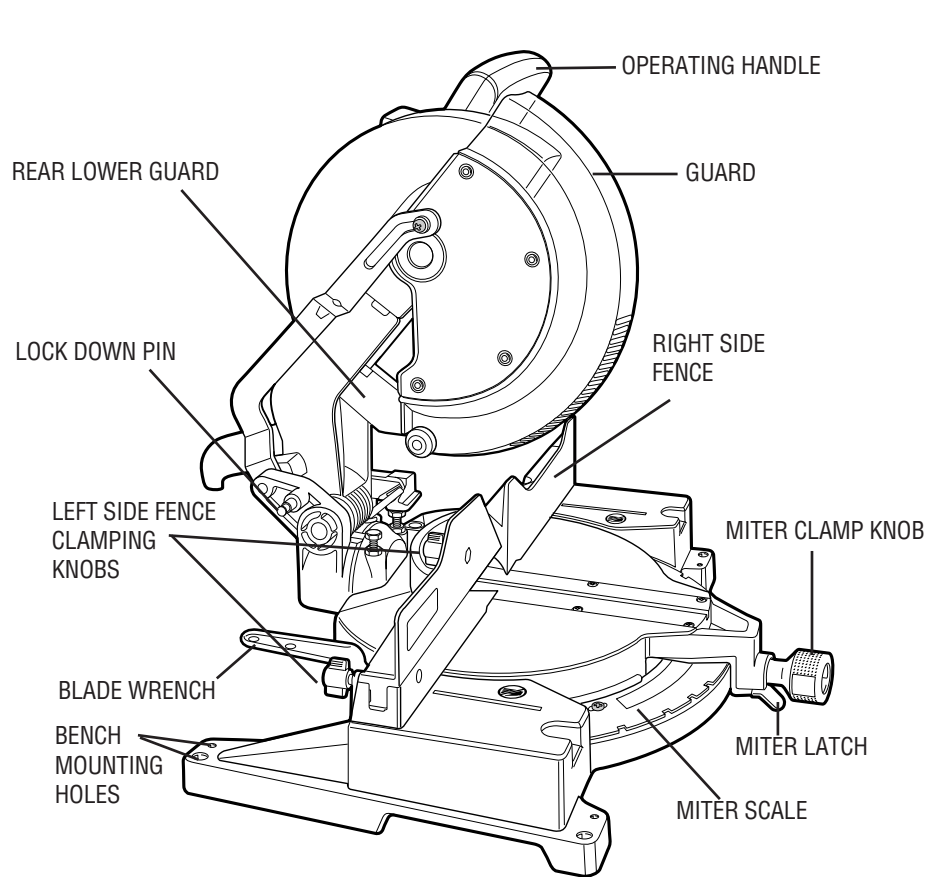

Table of Contents

SAFETY INSTRUCTIONS.....	1
ADDITIONAL SAFETY RULES	2
ELECTRICAL CONNECTION	2
GROUNDING INSTRUCTIONS	2
EXTENSION CORDS.....	3
UNPACKING YOUR SAW	3
FAMILIARIZATION	3
SPECIFICATIONS	3
BENCH MOUNTING	3
INSTALLING THE BLADE.....	4
REAR LOWER GUARD ADJUSTMENT.....	4
CUTTING THE KERF.....	4
TRANSPORTING THE SAW	4
ADJUSTMENTS	4
MITER SCALE ADJUSTMENT	4
MITER POINTER ADJUSTMENT.....	5
BEVEL STOP ADJUSTMENT	5
FENCE ADJUSTMENT	5
GUARD ACTUATION AND VISIBILITY	5
AUTOMATIC ELECTRIC BRAKE	6
SWITCH	6
CUTTING WITH YOUR SAW	6
CROSSCUTS	6
BEVEL CUTS	6
QUALITY OF CUT	6
BODY AND HAND POSITION	7
CLAMPING THE WORKPIECE.....	7
SUPPORT FOR LONG PIECES	7
CUTTING PICTURE FRAMES, SHADOW BOXES	7
AND OTHER FOUR SIDED PROJECTS	7
CUTTING TRIM MOLDING AND OTHER FRAMES	7
CUTTING COMPOUND MITERS	7
DUAL RANGE MITER SCALE.....	8
VERNIER SCALE	8
CUTTING BASEBOARD MOLDINGS	9
CUTTING CROWN MOLDING	10
TROUBLE SHOOTING TIPS	11
MAINTENANCE	12
ACCESSORIES	12

FOR YOUR SAFETY - ALL TOOLS

WARNING: When using Electric Tools, basic safety precautions should always be followed to reduce the risk of fire, shock, and personal injury, including the following:

READ ALL INSTRUCTIONS

1. **KEEP GUARDS IN PLACE** and in working order.
2. **REMOVE ADJUSTING KEYS AND WRENCHES.** Form habit of checking to see that keys and adjusting wrenches are removed from tool before turning it on.
3. **KEEP WORK AREA CLEAN.** Cluttered areas and benches invite accidents.
4. **DON'T USE IN DANGEROUS ENVIRONMENT.** Don't use power tools in damp or wet locations, or expose them to rain. Keep work area well lighted.
5. **KEEP CHILDREN AWAY.** All visitors should be kept at a safe distance from work area.
6. **MAKE WORKSHOP KID PROOF** with padlocks, master switches, or by removing starter keys.
7. **DON'T FORCE TOOL.** It will do the job better and be safer at the rate for which it was designed.
8. **USE RIGHT TOOL.** Don't force tool or attachment to do a job for which it was not designed.
9. **WEAR PROPER APPAREL.** No loose clothing, gloves, neckties, rings, bracelets, or other jewelry to get caught in moving parts. Nonslip footwear is recommended. Wear protective hair covering to contain long hair.
10. **ALWAYS WEAR SAFETY GLASSES.** Also use face or dust mask if cutting operation is dusty. Everyday eyeglasses have only impact resistant lenses. They are NOT safety glasses.
11. **SECURE WORK.** Use clamps or vise to hold work when practical. It's safer than using your hand and it frees both hands to operate tool.
12. **DON'T OVERREACH.** Keep proper footing and balance at all times.
13. **MAINTAIN TOOLS WITH CARE.** Keep tools sharp and clean for best and safest performance. Follow instructions for lubricating and changing accessories.
14. **DISCONNECT TOOLS** before servicing; when changing accessories such as blades, bits, cutters, etc.
15. **REDUCE THE RISK OF UNINTENTIONAL STARTING.** Make sure switch is in OFF position before plugging in.
16. **USE RECOMMENDED ACCESSORIES.** Consult the instruction manual for recommended accessories. The use of improper accessories may cause risk of injury to persons.
17. **NEVER STAND ON TOOL.** Serious injury could occur if the tool is tipped or if the cutting tool is unintentionally contacted.
18. **CHECK DAMAGED PARTS.** Before further use of the tool, a guard or other part that is damaged should be carefully checked to determine that it will operate properly and perform its intended function—check for alignment of moving parts, binding of moving parts, breakage of parts, mounting and any other conditions that may affect its operation. A guard or other part that is damaged should be properly repaired or replaced.
19. **NEVER LEAVE TOOL RUNNING UNATTENDED. TURN POWER OFF.** Don't leave tool until it comes to a complete stop.
20. **DO NOT OPERATE ELECTRIC TOOLS NEAR FLAMMABLE LIQUIDS OR IN GASEOUS OR EXPLOSIVE ATMOSPHERES.** Motors in these tools may spark and ignite fumes.

SAFETY INSTRUCTIONS - MITER SAWS

1. **CAUTION: FAILURE TO HEED THESE WARNINGS MAY RESULT IN PERSONAL INJURY AND SERIOUS DAMAGE TO THE SAW.**
2. **DO**-Protect electric supply line with at least a 15 ampere time-delay fuse or a circuit breaker.
3. **DO**-Make certain the blade rotates in the correct direction and that the teeth at the bottom of the blade are pointing to the rear of the miter saw.
4. **DO**-Be sure all clamp handles are tight before starting any operation.
5. **DO**-Be sure all blade and clamp washers are clean and recessed sides of collars are against blade. Tighten arbor screw securely.
6. **DO**- Keep saw blade sharp and properly set.
7. **DO**-Keep motor air slots free of chips and dirt.
8. **DO**-Use blade guards at all times.
9. **DO**-Keep hands out of path of saw blade.
10. **DO**-Shut off power, disconnect cord from power source and wait for saw blade to stop before servicing or adjusting tool.
11. **DO**-Support long work with an outboard tool rest.
12. **DON'T**-Attempt to operate on anything but designated voltage.
13. **DON'T**-Operate unless all clamp handles are tight.
14. **DON'T**- Use blades larger or smaller than those which are recommended.
15. **DON'T**- Wedge anything against fan to hold motor shaft.
16. **DON'T**-Force cutting action. (Stalling or partial stalling of motor can cause major damage. Allow motor to reach full speed before cutting.)
17. **DON'T**- Cut ferrous metals (Those with any iron or steel content) or any masonry.
18. **DON'T**-Use abrasive wheels. The excessive heat and abrasive particles generated by them will damage the saw.
19. **DON'T**-Allow anyone to stand behind saw.
20. **DON'T**-Apply lubricants to the blade when it's running.
21. **DON'T**-Place either hand in the blade area when the saw is connected to the power source.
22. **DON'T**-Use blades rated less than 4800 R.P.M.
23. **DON'T**-Attempt to cut small pieces (6") without clamping.
24. **DON'T**-Operate saw without guards in place.
25. **DON'T**-Perform any operation freehand.
26. **DON'T**-Reach around or behind saw blade.
27. **DON'T**-Place hands closer than 6 inches from the saw blade.
28. **DON'T** - Reach underneath the saw unless it is turned off and unplugged. The saw blade is exposed on the underside of the saw.
29. **DON'T** - Move either hand from saw or work piece or raise arm until blade has stopped.
30. **DON'T** - Use without Kerf Plate or when kerf slot is wider than 3/8".
31. **CAUTION:** Do not connect unit to electrical power source until complete instructions are read and understood.
32. **CAUTION:** Some wood contains preservatives such as copper chromium arsenate (CCA) which can be toxic. When cutting these materials extra care should be taken to avoid inhalation and minimize skin contact.

For your convenience and safety, the following warning labels are on your miter saw.

ON MOTOR HOUSING:

WARNING: FOR YOUR OWN SAFETY, READ INSTRUCTION MANUAL BEFORE OPERATING SAW. WHEN SERVICING, USE ONLY IDENTICAL REPLACEMENT PARTS. ALWAYS WEAR EYE PROTECTION.

ON MOVING FENCE: ALWAYS ADJUST FENCE PROPERLY BEFORE USE. CLAMP SMALL PIECES BEFORE CUTTING. SEE MANUAL.

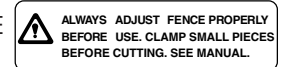

ON GUARD:

DANGER – KEEP AWAY FROM BLADE.



ON TABLE: (2 PLACES)



ALWAYS TIGHTEN ADJUSTMENT KNOBS BEFORE USE. KEEP HANDS 6" FROM PATH OF SAW BLADE. NEVER PERFORM ANY OPERATION FREEHAND. NEVER CROSS ARMS IN FRONT OF SAW BLADE. THINK! YOU CAN PREVENT ACCIDENTS.

DO NOT OPERATE SAW WITHOUT GUARDS IN PLACE. NEVER REACH IN BACK OF SAW BLADE. ALWAYS WEAR EYE PROTECTION. SHUT OFF POWER AND WAIT FOR BLADE TO STOP BEFORE SERVICING, ADJUSTING TOOL, OR MOVING HANDS.

SAVE THESE INSTRUCTIONS FOR FUTURE USE

Electrical Connection

Be sure your power supply agrees with the nameplate marking. 120 volts, AC/DC means that your saw will operate on alternating or direct current. A voltage decrease of 10 percent or more will cause a loss of power and overheating. All B&D tools are factory tested. If this tool does not operate, check the power supply.

Grounding

In the event of a malfunction or breakdown, grounding provides a path of least resistance for electric current to reduce the risk of electric shock. This tool is equipped with an electric cord having an equipment-grounding conductor and a grounding plug. The plug must be plugged into a matching outlet that is properly installed and grounded in accordance with all local codes and ordinances. Do not modify the plug provided. If it will not fit the outlet, have the proper outlet installed by a qualified electrician.

This tool is intended for use on a circuit that has an outlet like the one illustrated in sketch A. The tool has a grounding plug that looks like the plug illustrated in sketch A. A temporary adapter, which looks like the adapter illustrated in sketches B and C, may be used to connect this plug to a 2-pole receptacle as shown in

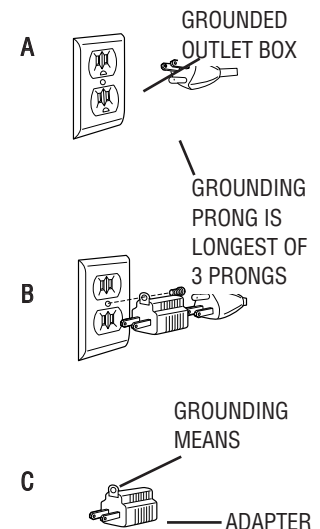

sketch B if a properly grounded outlet is not available. The temporary adapter should be used only until a properly grounded outlet can be installed by a qualified electrician. The green-colored rigid ear, lug, and the like, extending from the adapter must be connected to a permanent ground such as a properly grounded outlet box.

ADAPTER SHOWN IN FIGURES B & C IS NOT FOR USE IN CANADA.

Extension Cords

Tools that have 3 wire cords requiring grounding must only be used with extension cords that have 3-prong grounding type plugs and 3-pole receptacles. Only round jacketed extension cords should be used, and we recommend that they be listed by Underwriters Laboratories (U.L.) (C.S.A. in Canada). If the extension will be used outside, the cord must be suitable for outdoor use. The letters "WA" on the cord jacket indicate that it is suitable for outdoor use. Any cord marked as outdoor can also be used for indoor work.

An extension cord must have adequate wire size (AWG or American Wire Gauge) for safety, and to prevent loss of power and overheating. The smaller the gauge number of the wire, the greater the capacity of the cable, that is 16 gauge has more capacity than 18 gauge. When using more than one extension to make up the total length, be sure each individual extension contains at least the minimum wire size. To determine the minimum wire size required, refer to the following chart:

120 VOLT TOOLS: CHART FOR MINIMUM WIRE SIZE (AWG) OF EXTENSION CORDS

Cord Length (feet)	25	50	75	100
Gauge:	16	14	12	10

Before using an extension cord, inspect it for loose or exposed wires, damaged insulation, and defective fittings. Make any needed repairs or replace the cord if necessary. B&D has extension cords available that are U.L. (C.S.A. in Canada) listed for outdoor use.

Unpacking Your Saw

Check the contents of your miter saw carton to make sure that you have received all parts. In addition to this instruction manual, the carton should contain: one 3680 miter saw, one carbide saw blade and one blade wrench in wrench pocket.

Familiarization

Your miter saw is fully assembled in the carton. Open the box and lift the saw out by the convenient carrying handle, as shown in Figure 1. Place the saw on a smooth, flat surface such as a workbench or strong table. Examine Figures on inside front cover of this manual to become familiar with the saw and its various parts. The following section on adjustments will refer to these terms and you must know what the parts are.

Press down lightly on the operating handle and pull out the lock down pin, as shown in Figure 2. Gently release the downward pressure and allow the arm to rise to its full height. Use the lock down pin when carrying the saw from one place to another. Always use the carrying handle or the hand indentations to transport the saw.

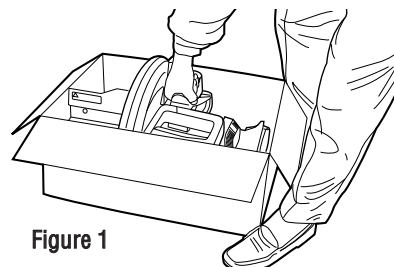

Figure 1

ADJUSTMENT AND SET UP

Specifications

Capacity of cut

48° miter left and right
48° bevel left: 3° right

0° miter
Max. Height 3.9" Result Width 5.9"
Max. Width 7.9" Result Height 2.5"

45° miter
Max. Height 3.9" Result Width 4.1"
Max. Width 5.5" Result Height 2.5"

45° bevel
Max. Height 2.7" Result Width 5.9"
Max Width 7.9" Result Height 1.7"

Drive

2000 Watts out 13 Amp Motor
Cut Helical Gears with Ball Bearings
Carbide Blade, 4000 RPM
Automatic Electric Brake

Bench Mounting

Holes are provided in all four feet to facilitate bench mounting. (Two different sized holes are provided to accommodate different sizes of screws. Use either hole, it is not necessary to use both.) Always mount your saw firmly to prevent movement. To enhance the tool's portability, it can be mounted to a piece of 1/2" or thicker plywood which can then be clamped to your work support or moved to other job sites and reclamped.

NOTE: If you elect to mount your saw to a piece of plywood, make sure that the mounting screws don't protrude from the bottom of the wood. The plywood must sit flush on the work support. When clamping the saw to any work surface, clamp only on the clamping bosses where the mounting screw holes are located. Clamping at any other point will surely interfere with the proper operation of the saw.

CAUTION: To prevent binding and inaccuracy, be sure the mounting surface is not warped or otherwise uneven. If the saw rocks on the surface, place a thin piece of material under one saw foot until the saw sits firmly on the mounting surface.

Figure 2

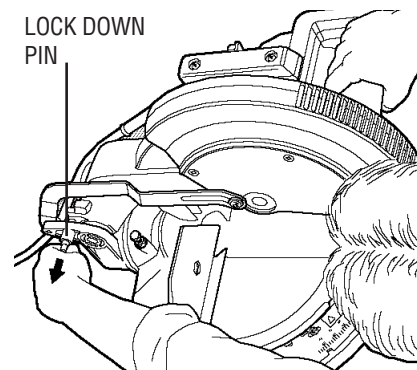
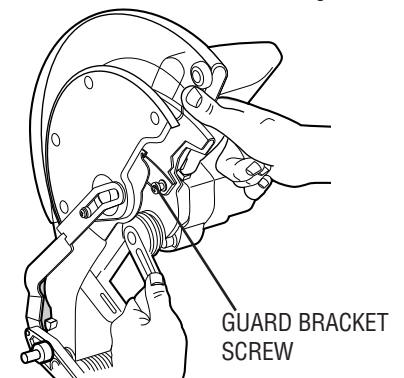

Figure 3



Installing the Blade

TURN OFF TOOL AND DISCONNECT FROM POWER SUPPLY.

DO NOT CUT FERROUS METAL (THAT WITH AN IRON OR STEEL CONTENT) OR MASONRY WITH THIS MITER SAW.

1. With the saw arm in the upper position, raise the lower guard as far as possible.
2. Loosen (but do not remove) the guard bracket screw, shown in Figure 3 until the guard bracket can be raised enough to permit access to the blade screw.
3. Hold the lower guard up and depress the spindle lock button with one hand and use the supplied blade wrench in the other hand to loosen (clockwise) the left hand threaded blade screw. **NOTE:** To use the spindle lock, depress the button as shown and rotate the spindle by hand until you feel the lock engage. Continue to hold the lock button in to keep the spindle from turning.
4. Install the saw blade making sure that the teeth at the bottom edge of the blade are pointing toward the back of the saw (away from the operator).
5. Replace the outer blade washer and tighten the blade screw (counterclockwise) while holding the lower guard up and the spindle lock engaged with your other hand.

NEVER DEPRESS THE SPINDLE LOCK BUTTON WHILE THE BLADE IS ROTATING.

AFTER INSTALLING THE SAW BLADE, REPOSITION GUARD BRACKET MAKING SURE IT IS FULLY SEATED ON GUARD SCREW. FIRMLY TIGHTEN SCREW. FAILURE TO DO SO WILL CAUSE SERIOUS DAMAGE TO THE SAW.

Rear Lower Guard Adjustment

Check the rear lower guard to ensure that it is located such that the saw blade is in the center and equidistant from each side, as shown in Figures 4 & 5. Adjust as necessary by loosening the two screws and moving the guard. Firmly tighten both screws. Never remove this guard.

Cutting the Kerf

In order to adjust and use your miter saw, you must cut a slot through the kerf plate to allow for blade clearance. To cut the kerf plate:

1. Set the saw at 0° miter.
2. Place a piece of scrap wood on the kerf plate at least 1"x6"x12".
3. Turn the saw on and allow the blade to reach full speed.
4. Pull the saw arm down as far as it will go and CUT SLOWLY THROUGH THE SCRAP WOOD AND THE PLASTIC KERF PLATE.
5. Turn the saw off and allow the blade to stop before raising the saw arm.
6. Loosen and move the left side of the fence as far as it will go to the left.
7. Now adjust the bevel angle to 45°.
8. Once again, turn on the saw and allow the blade to reach full speed.
9. Pull the arm down and cut slowly through the wood and kerf plate again. (This procedure will widen the kerf plate cut so that the blade will pass through it at any angle from 0° to 45°).

Be sure to adjust the left side of the fence so that it's as close to the saw blade as possible without interfering with arm up & down movement. Tighten the fence in position using both knobs. Don't use without kerf plate or when kerf slot is wider than 3/8".

Transporting the Saw

TURN OFF TOOL AND DISCONNECT FROM POWER SUPPLY.

In order to conveniently carry the miter saw from place to place, a carrying handle has been included on the top of the saw arm. To transport the saw, lower the arm and depress the lock down pin shown in Figure 2.

NOTE: The saw arm cannot be fully lowered if the tool has a blade installed unless the kerf plate has been cut. If you wish to transport the saw before cutting the kerf plate, remove the saw blade.

Adjustments

PERFORM ALL ADJUSTMENTS WITH THE MITER SAW UNPLUGGED!

NOTE: Your miter saw is fully and accurately adjusted at the factory at the time of manufacture. If readjustment due to shipping and handling or any other reason is required, follow the steps below to adjust your saw. Once made, these adjustments should remain accurate. Take a little time now to follow these directions carefully to attain the accuracy of which your saw is capable.

Miter Scale Adjustment

TURN OFF TOOL AND DISCONNECT FROM POWER SUPPLY.

1. Place a square against the saw's fence and blade, as shown in Figure 6. (Do not touch the tips of the blade teeth with the square. To do so will cause an inaccurate measurement.)
2. Loosen the miter clamp knob (Figure 7) and swing the miter arm until the miter latch locks it at the 0 miter position. Do not tighten the clamp knob.
3. If the saw blade is not exactly perpendicular to the fence, loosen the three screws that hold the miter scale to the base (Figure 7) and move the scale/miter arm assembly left or right until the blade is perpendicular to the fence, as measured with the square.
4. Retighten the three screws. Pay no attention to the reading of the miter pointer at this time.

Figure 4

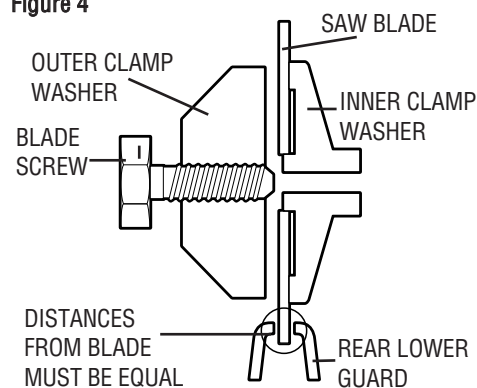

Figure 5

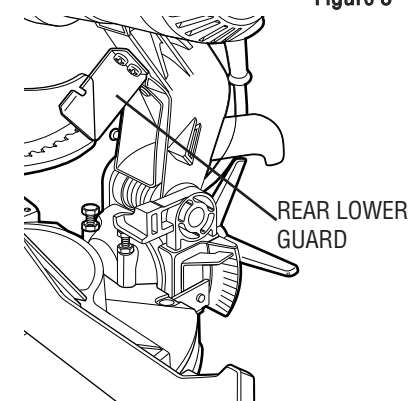

Figure 6

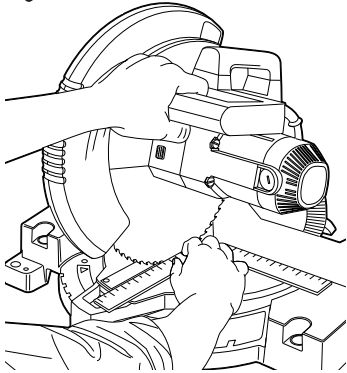
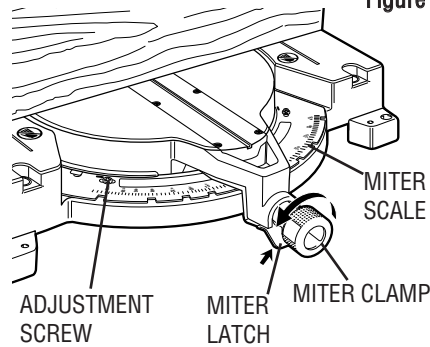

Figure 7



Miter Pointer Adjustment

TURN OFF TOOL AND DISCONNECT FROM POWER SUPPLY.

1. Loosen the miter clamp knob and squeeze the miter latch to move the miter arm to the 0 position, as shown in Figure 7.
2. With the miter clamp knob loose, allow the miter latch to snap into place as you rotate the miter arm pass 0.
3. Observe the pointer and miter scale through the viewing opening shown in Figure 8. If the pointer does not indicate exactly 0, use a flat bladed screwdriver to gently pry it left or right as required.

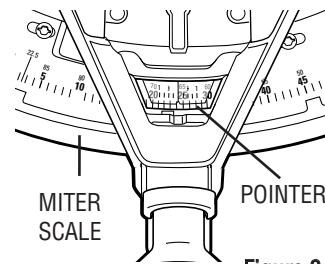

Figure 8

Bevel Stop Adjustment

TURN OFF TOOL AND DISCONNECT FROM POWER SUPPLY.

1. Lower the saw arm so that the blade just slightly goes through the kerf plate.
2. Place a square against the table and the blade, as shown in Figure 9. **NOTE:** Do not touch the tip of any blade teeth with the square; to do so will cause an inaccurate measurement.
3. Loosen the bevel clamp knob so that you can move the bevel arm.
4. Move the bevel arm as necessary so that the blade is at 0° bevel to the table.
5. If the bevel arm needs adjustment, loosen the lock nut on the right side bevel stop as shown in Figure 10, and adjust the stop screw as necessary.
6. Hold the stop screw in place and tighten the lock nut.
7. If the bevel pointer does not indicate 0, loosen the screw that holds it in place and move the pointer as necessary. **Suggestion:** The bevel pointer is quite thick so for accuracy's sake, set the pointer so that its top edge aligns with 0. This way all reading will be on the top edge of the pointer.
8. Loosen the left side fence clamping knobs, as shown in Figure 11 and slide the left side fence as far as it will go to the left.
9. Move the bevel arm to the left to the 45° setting.

If the bevel pointer does not indicate exactly 45°, the bevel arm is out of adjustment. To adjust the arm:

1. Loosen the lock nut on the left side bevel stop screw as shown in Figure 11.

2. Adjust the stop screw up or down as necessary until the pointer indicates 45° with the bevel arm resting against the left side bevel stop screw.
3. Hold the screw stationary while you firmly tighten the lock nut. **DO NOT ADJUST THE BEVEL POINTER.**

To achieve 3° right bevel or 48° left bevel, the top screws must be adjusted to allow the bevel arm to move as necessary. Re-adjust the bevel stops when the cuts are finished.

Fence Adjustment

TURN OFF TOOL AND DISCONNECT FROM POWER SUPPLY.

So that the saw can bevel to a full 48° left, the left side of the fence can be adjusted to the left to provide clearance. To adjust the fence:

1. Loosen the 2 plastic knobs shown in Figure 11 and slide the fence to the left.
2. Make a dry run with the saw turned off and check for clearance.
3. Adjust the fence to be as close to the blade as practical to provide maximum work piece support, without interfering with arm up & down movement.
4. Tighten both knobs securely.
5. When the bevel operations are complete, don't forget to relocate the fence to the right.

NOTE: The guide groove - Figure 12, of the left side fence can become clogged with sawdust. If you notice that it is becoming clogged, use a stick or some low pressure air to clear the guide groove.

Guard Actuation and Visibility

The blade guard on your saw has been designed to automatically raise when the arm is brought down and to lower over the blade when the arm is raised.

The guard can be raised by hand when installing or removing saw blades or for inspection of the saw. **NEVER RAISE THE BLADE GUARD MANUALLY UNLESS THE SAW IS TURNED OFF.**

NOTE: Certain special cuts will require that you manually raise the guard. (See page 9- Cutting Base Molding up to 3 7/8" High Vertically Against the Fence.)

The front section of the guard is louvered for visibility while cutting. Although the louvers dramatically reduce flying debris, they are openings in the guard and safety glasses should be worn at all times when viewing through the louvers.

Figure 9

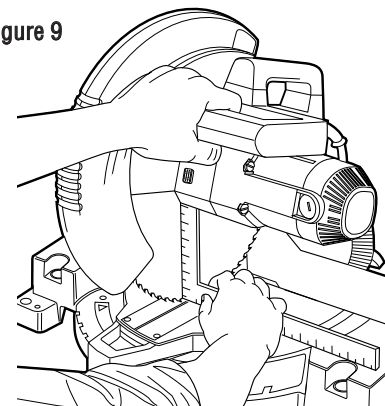
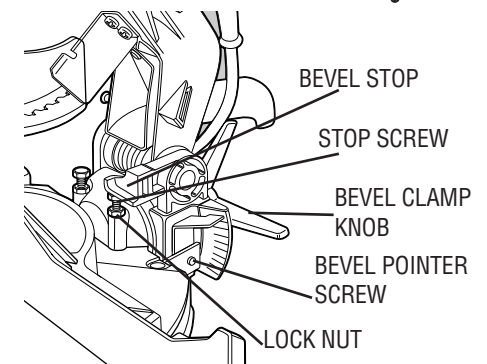

Figure 10



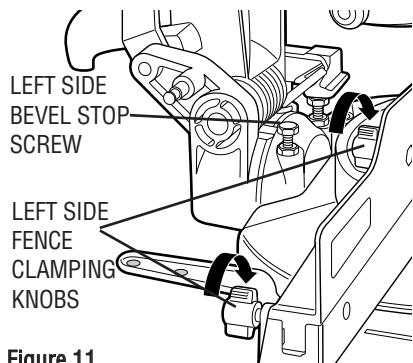

Figure 11

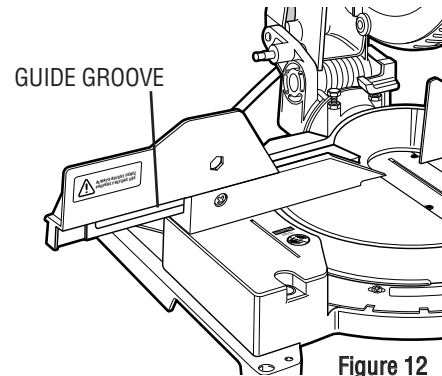

Figure 12

Electric Brake

Your saw is equipped with an electric blade brake which stops the saw blade within 5 seconds of trigger release. This is automatic and requires no adjustment.

Occasionally, under certain conditions, the brake will not function properly and won't stop the saw in the 5 seconds discussed above. If this condition persists, turn the saw on and off four or five times. If the brake still does not stop the blade in about 5 seconds, the problem may be worn brushes. Replace the brushes as described on page 12 and try the saw again. If this condition occurs, have the tool serviced at a B&D authorized service center.

TOOL OPERATION

Plug the saw into any 120 volt 60 Hz power source. Be sure the cord will not interfere with your work.

Switch

To turn the saw ON, depress the trigger switch- Figure 13. To turn the tool OFF, release the switch. There is no provision for locking the switch ON, but a hole is provided in the trigger for insertion of a padlock to lock the saw OFF.

If your saw will not start, check the following:

- Make sure tool is plugged in.
- Replace blown fuses or reset circuit breakers if needed.
- Have damaged cords replaced.
- Have worn out brushes replaced.

HOLE FOR PAD LOCK

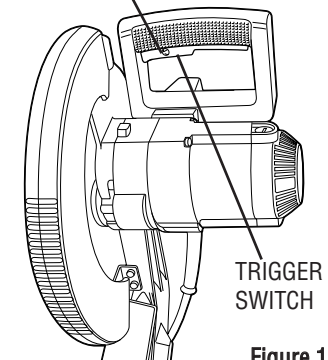

Figure 13

Cutting with your saw

NOTE: Although this saw will cut wood and many non-ferrous materials, we will limit our discussion to the cutting of wood only. The same guidelines apply to the other materials. **DO NOT CUT FERROUS (IRON AND STEEL) MATERIALS OR MASONRY WITH THIS SAW.** Do not use any abrasive blades.

Crosscuts

A crosscut is made by cutting wood across the grain at any angle. A straight crosscut is made with the miter arm at the 0° position. Set the miter arm at 0, hold the wood on the table and firmly against the fence. Turn on the saw by squeezing the trigger switch shown in Figure 13.

When the saw comes up to speed (about 1 second) lower the arm smoothly and slowly cut through the wood. Let the blade come to a full stop before raising arm.

Miter crosscuts are made with the miter arm at some angle other than 0°. This angle is often 45° for making corners, but can be set anywhere from 0° to 48° left or right. After selecting the desired miter angle, be sure to tighten the miter clamp knob. Make the cut as described above.

Bevel Cuts

A bevel cut is a crosscut made with the saw blade at a bevel to the wood. In order to set the bevel, loosen the bevel clamp knob and move the saw to the left as desired. (It is necessary to move the left side of the fence to allow clearance as you did under "Bevel Stop Adjustment". Once the desired bevel angle has been set, tighten the bevel clamp knob firmly.

Bevel angles can be set from 3° right to 45° left and can be cut with the miter arm set between 0° and 45° right or left.

Quality of Cut

The smoothness of any cut depends on a number of variables. Things like material being cut, blade type, blade sharpness and rate of cut all contribute to the quality of the cut.

When smoothest cuts are desired for molding and other precision work, a sharp (60 tooth or greater carbide) blade and a slower, even cutting rate will produce the desired results.

Ensure that material does not creep while cutting, clamp it securely in place. Always let the blade come to a full stop before raising the arm. If small fibers of wood still split out at the rear of the work piece, stick a piece of masking tape on the wood where the cut will be made. Saw through the tape and carefully remove tape when finished.

For varied cutting applications, refer to the list of recommended accessories for your saw and select the blade that best fits your needs.

Body and Hand Position (See Figure 14)

Proper positioning of your body and hands when operating the miter saw will make cutting easier, more accurate and safer. Never place hands near cutting area. Place hands no closer than 6" from the blade. Hold the work piece tightly to the table and the fence when cutting. Keep hands in position until the trigger has been released and the blade has completely stopped.

ALWAYS MAKE DRY RUNS (UNPOWERED) BEFORE FINISH CUTS SO THAT YOU CAN CHECK THE PATH OF THE BLADE. DO NOT CROSS HANDS AS SHOWN BELOW.

Keep both feet firmly on the floor and maintain proper balance. As you move the miter arm left and right, follow it and stand slightly to the side of the saw blade. Sight through the guard louvers when following a pencil line.

Clamping the Work Piece

TURN OFF TOOL AND DISCONNECT FROM POWER SUPPLY.

ALWAYS CLAMP WOOD TO THE SAW IF POSSIBLE AND ALWAYS CLAMP IF SIZE OF WORK PIECE REQUIRES YOUR HAND TO BE WITHIN 6" OF BLADE. You can clamp to either side of the saw blade and remember to position your clamp against a solid, flat surface of the fence. For best results use the 36802 clamp made for use with your saw. Available from your dealer at extra cost.

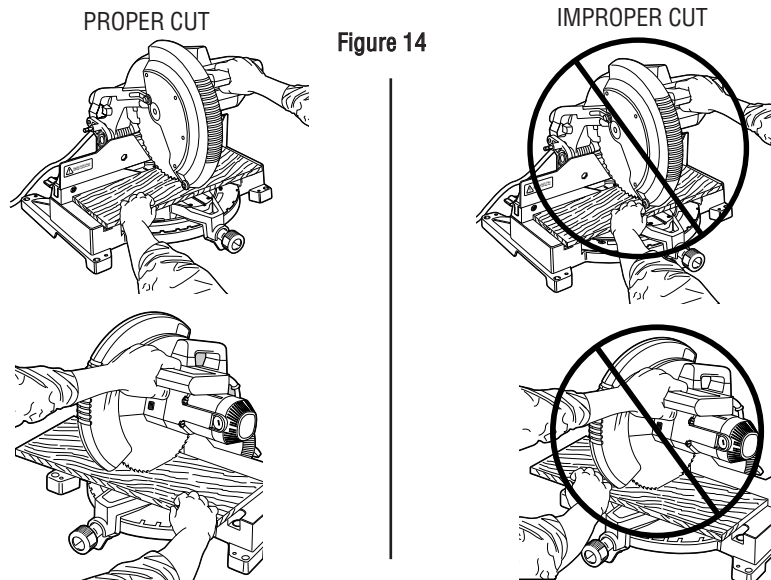

Figure 14

When clamping small pieces requiring your hand to be dangerously close (within 6") to the saw blade, a clamp **MUST** be used to prevent loss of control. The left fence may be adjusted to aid clamping.

Support for Long Pieces

TURN OFF TOOL AND DISCONNECT FROM POWER SUPPLY.

For best results, use the 36800 Extension Work Support to extend the table width of your saw. Available from your dealer at extra cost. Support long work pieces using any convenient means such as sawhorses or similar devices to keep the ends from dropping.

Cutting picture frames, shadow boxes, and other four sided projects

To best understand how to make the items listed here, we suggest that you try a few simple projects using scrap wood until you develop a "FEEL" for your saw.

Your saw is the perfect tool for mitering corners like the one shown in Figure 15. Sketch A shows a joint made by using the bevel adjustment to bevel the edges of the two boards at 45° each to produce a 90° corner. For this joint the miter arm was locked in the 0 position and the bevel adjustment was locked at 45°. The wood was positioned with the broad flat side against the table and the narrow edge against the fence. The cut could also be made by mitering right and left with the broad surface against the fence.

Cutting Trim Molding and Other Frames

Sketch B in Figure 15 shows a joint made by setting the miter arm at 45° to miter the 2 boards to form a 90° corner. To make this type of joint, set the bevel adjustment to 0 and the miter arm to 45°. Once again, position the wood with the broad flat side on the table and the narrow edge against the fence.

The 2 sketches in Figure 15 are for four side objects only. As the number of sides changes, so do the miter and bevel angles. The chart below gives the proper angles for a variety of shapes. (The chart assumes that all sides are of equal length.) For a shape that is not shown in the chart, use the following formula. 180° divided by the number of sides equals the miter or bevel angle.

Cutting Compound Miters

A compound miter is a cut made using a miter angle and a bevel angle at the same time. This is the type of cut used to make frames or boxes with slanting sides like the one shown in Figure 16.

Figure 15

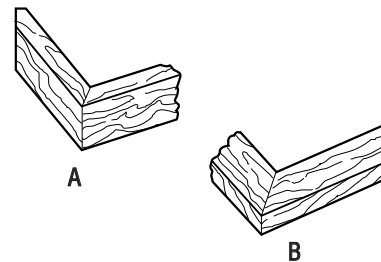

- EXAMPLES -

NO. SIDES	MITER ANGLE
4	45°
5	36°
6	30°
7	25.7°
8	22.5°
9	20°
10	18°

Figure 16

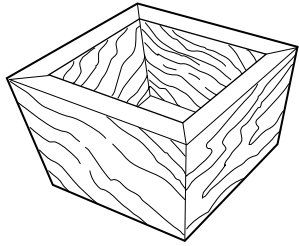
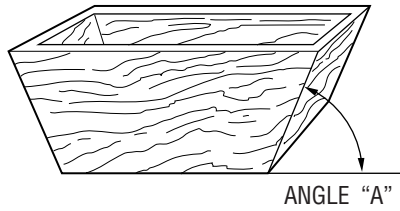

Figure 17



NOTE: If the cutting angle varies from cut to cut, check that the bevel clamp knob and the miter lock knob are securely tightened. These knobs must be tightened after making any changes in bevel or miter.

The chart shown on page 10 will assist you in selecting the proper bevel and miter settings for common compound miter cuts. To use the chart, select the desired angle “A” (Figure 17) of your project and locate that angle on the appropriate arc in the chart. From that point follow the chart straight down to find the correct bevel angle and straight across to find the correct miter angle.

Set your saw to the prescribed angles and make a few trial cuts. Practice fitting the cut pieces together until you develop a feel for this procedure and feel comfortable with it.

Example: To make a 4 sided box with 25° exterior angles (Angle A, Table 1), use the upper right arc. Find 25° on the arc scale. Follow the horizontal intersecting line to either side to get miter angle setting on saw (23°). Likewise, follow the vertical intersecting line to the top or bottom to get the bevel angle setting on the saw (40°). Always try cuts on a few scrap pieces of wood to verify settings on saw.

Dual Range Miter Scale

The miter scale has two ranges of numbers for convenience, as shown in Figure 18. One scale indicates 0° when the blade is square to the fence. At this position the other scale reads 90°.

The 0° scale (larger numbers closer to the front edge) is used when calculating angles. To calculate the proper miter angle, divide 180° by the number of sides of the box or frame. Refer to the chart on page 7 for some examples.

The 90° scale (smaller numbers behind the 0° scale) is used when a corner of your box or frame is measured with a protractor. **For example:** if you measure the corner of an 8 sided box, the protractor will read 135°. To determine the proper miter setting, divide the measured angle by two. The proper miter setting in this example is 67-1/2°. Set this angle on the 90° scale. This is most useful when a corner is at an odd angle.

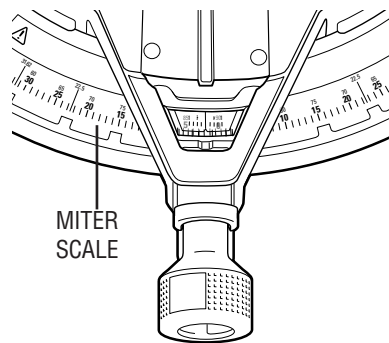
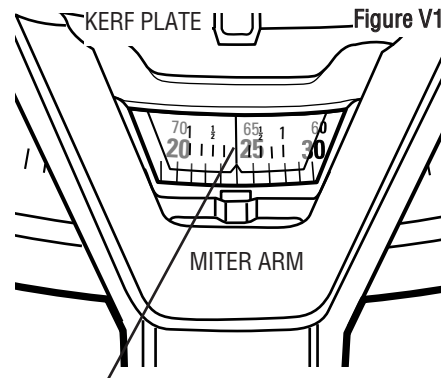
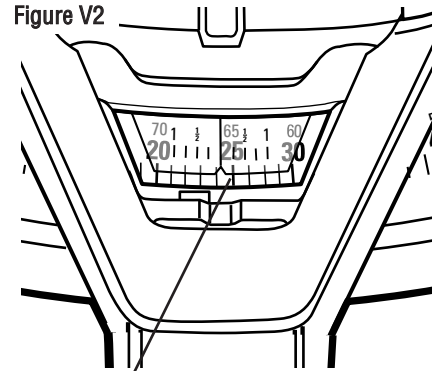

Figure 18



CENTER MARK ON VERNIER SCALE ALIGNS WITH DESIRED WHOLE ANGLE ON MITER SCALE (24° RIGHT MITER)

Figure V2



1/4° VERNIER MARK ALIGNS WITH CLOSEST WHOLE DEGREE MARK ON MITER SCALE (24° 1/4° RIGHT MITER).

Vernier Scale

Your saw is equipped with a vernier scale for added precision. The vernier scale allows you to accurately set miter angles to the nearest 1/4° (15 minutes). To use the vernier scale follow the steps listed below.

(As an example, let's assume that the angle you want to miter is 24 1/4° right).

1. Turn off miter saw.
2. Set the miter angle to the nearest whole degree desired by aligning the center mark in the vernier scale, shown in Figure V1, with the whole degree number etched in the miter scale. Examine Figure V1 closely; the setting shown is 24° right miter.
3. To set the additional 1/4°, squeeze the miter arm lock and carefully move the arm to the RIGHT until the 1/4° vernier mark aligns with the CLOSEST degree mark on the miter scale. In our example, the closest degree mark on the miter scale happens to be 25°. Figure V2 shows a setting of 24-1/4° right miter.

For settings that require partial degrees (1/4°, 1/2°, 3/4°) align the desired vernier mark with the CLOSEST degree mark on the miter scale, as described below (The plastic vernier plate is inscribed with marks for 1/4°, 1/2°, 3/4° and 1°. Only the 1/2° and the 1° are numerically labeled.)

When Mitering to the Right

To increase the miter angle when mitering to the right, move the arm to align the appropriate vernier mark with the closest mark on the miter scale to the right. To decrease the miter angle when mitering to the right, move the arm to align the appropriate vernier mark with the closest mark on the miter scale to the left.

When Mitering to the Left

To increase the miter angle when mitering to the left, move the arm to align the appropriate vernier mark with the closest mark on the miter scale to the left. To decrease the miter angle when mitering to the left, move the arm to align the appropriate vernier mark with the closest mark on the miter scale to the right.

Cutting Base Molding

ALWAYS MAKE A DRY RUN WITHOUT POWER BEFORE MAKING ANY CUTS.

Straight 90° cuts – Position the wood against the fence and clamp it in place as shown in Figure 19. Turn on the saw, allow the blade to reach full speed and lower the arm smoothly through the cut.

Cutting base molding up to 3-7/8" high vertically against the fence

Position molding as shown in Figure 20. All cuts made with the back of the molding against the fence and bottom of the molding against the table.

INSIDE CORNER:

- Left side: 1. Miter left 45°
2. Save left side of cut
- Right side: 1. Miter Right 45°
2. Save right side of cut

OUTSIDE CORNER:

- Left side: 1. Miter right at 45°
2. Save left side of cut
- Right side: 1. Miter left at 45°
2. Save right side of cut

Material up to 3.9" (3-7/8") can be cut as described above. For wider boards [up to 5.5" (5-1/2")] several minor concessions must be made.

When cutting a board between 3.9" (3-7/8") and 5.5" (5-1/2") in width the guard will hang up on the work piece. If this occurs, simply place your right thumb on the upper side of the guard and roll the guard up just enough to clear the work piece, as shown in Figure 23. Once you have cleared the work piece, you can release the guard and it will continue to open as the cut progresses.

When mitering to the right side of a base molding wider than 3.9" (3-7/8") standing vertically against the fence as in Figure 20, the saw can only cut through the board up to 1 inch from the end of the board. Trying to cut more than an inch will cause the saw's gear case to interfere with the work piece. If you want to cut base molding between 3-7/8" and 5-1/2" wide vertically see the following the directions.

Figure 19

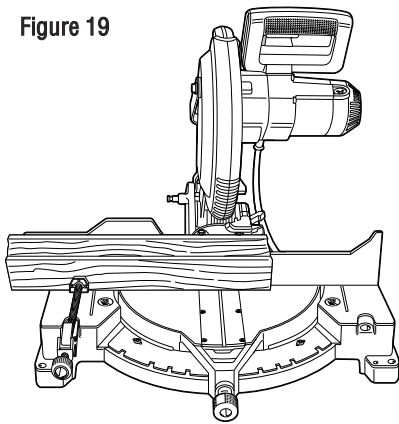
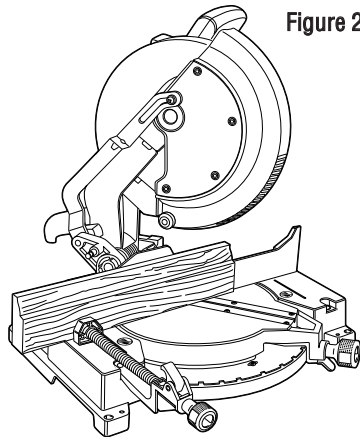

Figure 20



Cutting 3-7/8"– 5-1/2" base molding vertically against the fence

Position molding as shown in Figure 20. All cuts made with the back of the molding against the fence.

INSIDE CORNER:

- Left side: 1. Position molding with bottom of molding against the table of the saw
2. Miter left 45°
3. Save left side of cut
- Right side: 1. Position molding with top of the molding resting on the table of the saw
2. Miter left 45°
3. Save left side of cut

OUTSIDE CORNER:

- Left side: 1. Position molding with bottom of molding against the table of the saw
2. Miter right 45°
3. Save left side of cut

NOTE: If the cut must be made somewhere other than 1" from the end of the molding: cut off the molding at 90° approx. 1" longer than your final length then make the miter cut as described above.

- Right side: 1. Position molding with bottom of the molding against the table of the saw
2. Miter left 45°
3. Save the right side of cut

A third method of making the cut necessary for sketch A (Figure 15) is to make a 0° miter, 45° bevel cut. Your saw can cut a bevel 7 7/8" wide.

Cutting Base Molding Laying Flat and Using the Bevel Feature

All cuts made with the saw set at 45° and 0 miter.

All cuts made with back of molding laying flat on the saw as shown in Figures 21 and 22.

INSIDE CORNER:

- Left side: 1. Position molding with top of molding against the fence
2. Save left side of cut
- Right side: 1. Position molding with bottom of the molding against the fence
2. Save left side of cut

OUTSIDE CORNER:

- Left side: 1. Position molding with bottom of molding against the fence
2. Save right side of cut
- Right side: 1. Position molding with top of the molding against the fence
2. Save right side of cut

Figure 21

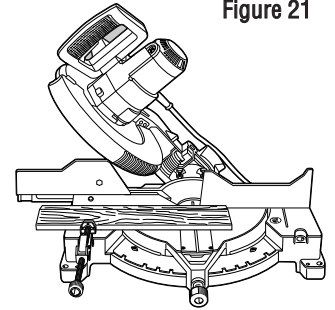

Figure 22

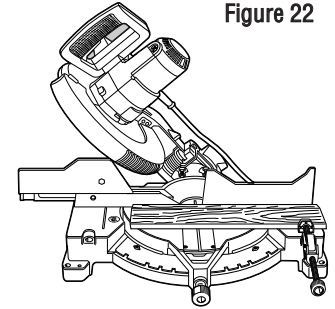

Figure 23

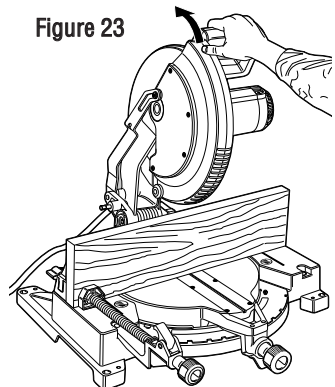
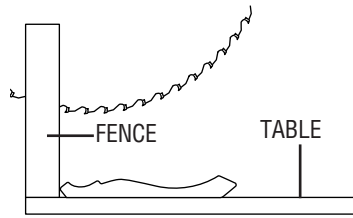
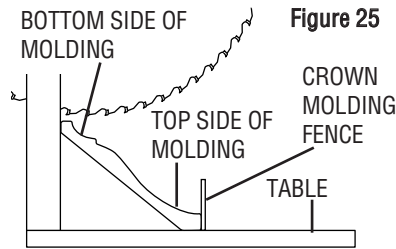

Figure 24



CROWN MOLDING FLAT ON TABLE AND AGAINST FENCE

Figure 25



CROWN MOLDING FENCE AND TABLE

Cutting Crown Molding

Your miter saw is better suited to the task of cutting crown molding than any tool made. In order to fit properly, crown molding must be mitered with extreme accuracy. The two flat surfaces on a given piece of crown molding are at angles that, when added together, equal exactly 90°. Most, but not all, crown molding has a top rear angle (the section that fits flat against the ceiling) of 52° and a bottom rear angle (the part that fits flat against the wall) of 38°.

Your miter saw has special preset miter latch points at 31.62° left and right for cutting crown molding at the proper angle. There is also a mark on the bevel scale at 33.85°.

The chart on the next page gives the proper settings for cutting crown molding. (The numbers for the miter and bevel settings are very precise and are not easy to accurately set on your saw.) Since most rooms do not have angles of precisely 90°, you will have to fine tune your settings anyway.

PRETESTING WITH SCRAP MATERIAL IS EXTREMELY IMPORTANT!

ALTERNATIVE METHOD FOR CUTTING CROWN MOLDING

Place the molding on the table at an angle between the fence and the saw table, as shown in Figure 25. Use of the crown molding fence accessory is highly recommended because of its degree of accuracy and convenience. The crown molding fence accessory is available at extra cost from your local dealer or B&D service center.

The advantage to cutting crown molding using this method is that no bevel cut is required. Minute changes in the miter angle can be made without affecting the bevel angle. This way, when corners other than 90° are encountered, the saw can be quickly and easily adjusted for them.

Use the 36807 crown molding fence accessory to maintain the angle at which the molding will be on the wall. Place the bottom side (the side that will be against the wall) against the miter saw fence.

INSTRUCTIONS FOR CUTTING CROWN MOLDING ANGLED BETWEEN THE FENCE AND THE TABLE OF THE SAW FOR ALL CUTS:

1. Angle the molding so the bottom of the molding (part which goes against the wall when installed) is against the fence and the top of the molding is resting on the base of the saw, as shown in Figure 25.
2. The angled "flats" on the back of the molding must rest squarely on the fence and base of the saw.

TABLE 1 COMPOUND MITER CUT

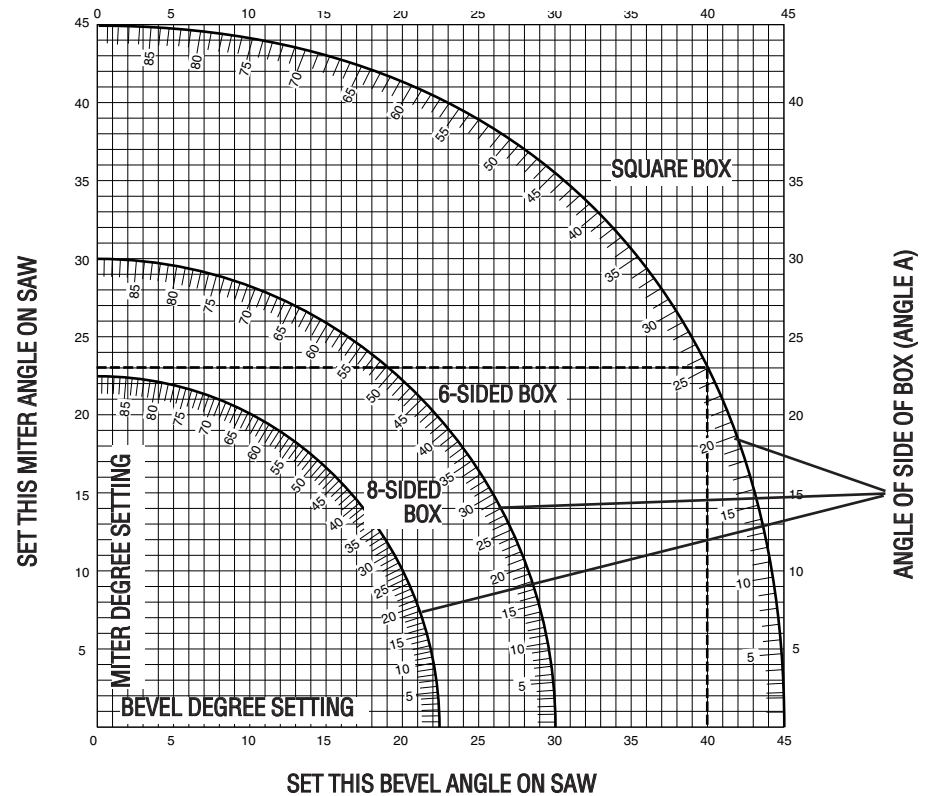

Instructions for cutting crown molding laying flat and using the compound features.

1. Molding laying with broad back surface down flat on saw table (See Figure 24).
2. The settings below are for all standard U.S. crown molding with 52° and 38° angles.

Bevel Setting	Type of Cut
33.85°	LEFT SIDE, INSIDE CORNER: 1. Top of molding against fence 2. Miter table set right 31.62° 3. Save left end of cut
33.85°	RIGHT SIDE, INSIDE CORNER: 1. Bottom of molding against fence 2. Miter table set left 31.62° 3. Save left end of cut
33.85°	LEFT SIDE, OUTSIDE CORNER: 1. Bottom of molding against fence 2. Miter table set left 31.62° 3. Save right end of cut
33.85°	RIGHT SIDE, OUTSIDE CORNER: 1. Top of molding against fence 2. Miter table set right 31.62° 3. Save right end of cut

When setting bevel and miter angles for all compound miters, remember that the angles presented for crown moldings are very precise and difficult to set exactly. Since they can easily shift slightly and very few rooms have exactly square corners, all settings should be tested on scrap molding.

PRETESTING WITH SCRAP MATERIAL IS EXTREMELY IMPORTANT!

INSIDE CORNER:

Left side: 1. Miter right at 45°
2. Save the right side of cut

Right side: 1. Miter left at 45°
2. Save left side of cut

OUTSIDE CORNER:

Left side: 1. Miter left at 45°
2. Save the right side of cut

Right side: 1. Miter right at 45°
2. Save left side of cut

ALWAYS MAKE DRY RUNS TO CHECK FOR CLEARANCE AND CORRECTNESS OF CUTS.

SPECIAL CUTS

NEVER MAKE ANY CUT WITHOUT FIRMLY CLAMPING THE MATERIAL.

Aluminum Cutting:

Aluminum extrusions such as those used when making aluminum screens and storm windows can easily be cut with your saw. Position the material so that you will be cutting the thinnest cross section, as shown in Figure 26. Figure 27 illustrates the wrong way to cut these extrusions.

Use a wax lubricant when cutting aluminum such as Johnson's Stick Wax No. 140. Apply the stick wax directly to the saw blade before cutting. Never apply stick wax to a moving blade.

The wax, available at most hardware stores and industrial mill supply houses, provides proper lubrication and keeps chips from adhering to the blade.

Bowed Material:

When cutting bowed material always position it as shown in Figure 28 and never like that shown in Figure 29. Positioning the material incorrectly will cause it to pinch the blade near the completion of the cut.

Cutting Plastic Pipe

Plastic pipe can be easily cut with your saw. It should be cut just like wood and **CLAMPED OR HELD FIRMLY TO THE FENCE TO KEEP IT FROM ROLLING.**

Figure 26

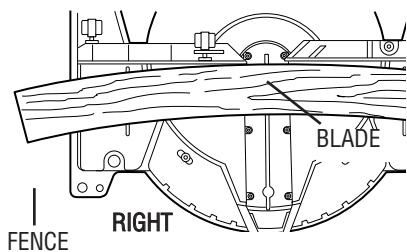

Figure 27

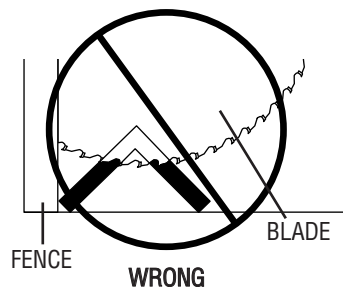

Figure 28

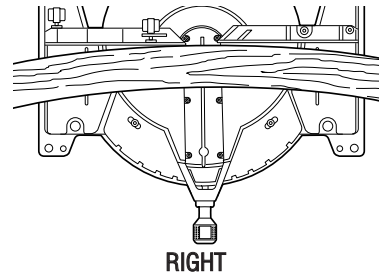
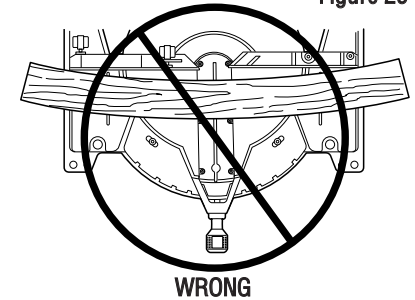

Figure 29



Cutting Large Material

Occasionally you will encounter a piece of wood a little too large to fit beneath the blade guard. A little extra height can be gained by rolling the guard up out of the way, as shown in Figure 23. Avoid doing this as much as possible, but if need be, the saw will operate properly and make the bigger cut. NEVER TIE, TAPE, OR OTHERWISE HOLD THE GUARD OPEN WHEN OPERATING THIS SAW.

Troubleshooting Tips

If your saw makes unsatisfactory cuts:

Replace dull blades
Check to see if blade is mounted backwards.
Remove blade and clean with turpentine and coarse steel wool or household oven cleaner.
Check to make sure the blade you are using is appropriate for work being done.

If blade does not come up to speed:

Extension cord may be too light or too long.
You may have low house current.

If your machine vibrates excessively:

Saw may not be mounted securely to stand on work bench.
Stand may be on uneven floor.
Blade may be damaged.

MAINTENANCE

1. All bearings are sealed ball bearings. They are lubricated for life and need no further maintenance.
2. Periodically clean all dust and wood chips from around AND UNDER the base and the rotary table. Even though slots are provided to allow debris to pass through, some dust will accumulate.
3. The brushes are designed to give you several years of use. If they ever need replacement follow the instructions below or return the tool to the nearest service center for repair. Service center locations are packed with your tool.

Brushes

Inspect carbon brushes regularly:

1. TURN OFF TOOL AND DISCONNECT FROM POWER SUPPLY.
2. Remove the brush inspection cap.
3. Withdraw the brush assembly.
4. Keep brushes clean and sliding freely in their guides. Always replace a used brush in the same orientation in the holder as it was prior to its removal. Carbon brushes have varying symbols stamped into their sides, and if the brush is worn down to the line closest to the spring, they must be replaced. (If either brush is worn out, replace both.) Use only identical B&D brushes. Use of the correct grade of brush is essential for proper operation of electric brake. New brush assemblies are available at B&D service centers.
5. The tool should be allowed to “run in” (run at no load) for 10 minutes before use to seat new brushes. The electric brake may be erratic in operation until the brushes are properly seated (worn in).

NOTE: While “running in” DO NOT TIE, TAPE, OR OTHERWISE LOCK THE TRIGGER SWITCH ON. HOLD BY HAND ONLY.

ACCESSORIES

Recommended accessories for use with your tool are available at extra cost from your distributor or local service center. A complete listing of service centers is included with your tool.

CAUTION: The use of any non-recommended accessory may be hazardous.

If you need any assistance in locating any accessory call 1-800-9-BD TOOL (1-800-923-8665) or contact Black & Decker (U.S.) Inc., Consumer Service Department, 626 Hanover Pike, P.O. Box 618, Hampstead, MD 21074.

Extension, Work Support: 36800

Used to support long overhanging work pieces, the work support is user assembled and stores conveniently under the saw table. Your saw table is designed to accept two work supports; one on each side.

Adjustable Length Stop: 36801

Requires the use of one work support (see Figure). It is used to make repetitive cuts of the same length from 0 to 42".

Clamp: 36802

Used for firmly clamping work piece to the saw fence for precision cutting

Dust Bag: 36803

Equipped with a zipper for easy emptying, the dust bag will capture the majority of the sawdust produced.

Note: Deflector on dust spout channels debris to ground. Spout has a provision to attach a vacuum hose to collect sawdust. Lift deflector to connect hose.

Crown Molding Fence: 36807

Used for precision cutting of crown molding. Position crown molding consistently at the proper angle from cut to cut.

Kit Box: 36806

Used to store and transport accessories.

APPLICATION	BLADE	NO. OF TEETH	TYPE OF CUT
Fine Trim Molding	Precision Ground Carbide	60-100	Very smooth splinter free
Trim, Framing, Pressure-Treated Decking	Combination Multi-Purpose	32-60	Smooth fast cut
Aluminum	Non-Ferrous Metal Cutting	60-80	_____

36800- EXTENSION, WORK SUPPORT

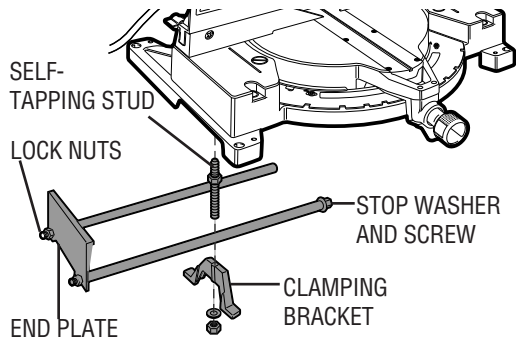

36801- ADJUSTABLE LENGTH STOP

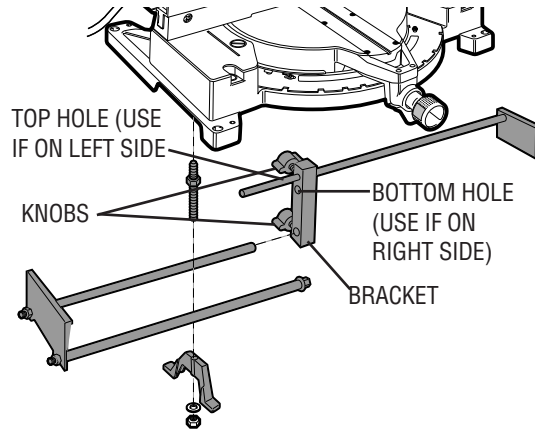

36802- CLAMP

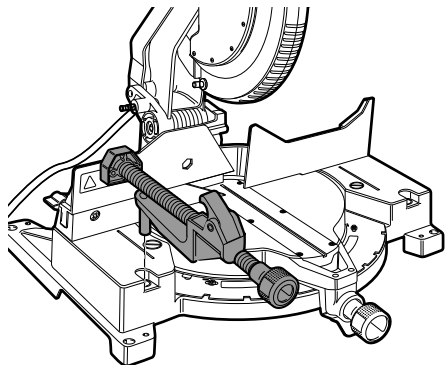

36807- CROWN MOLDING FENCE

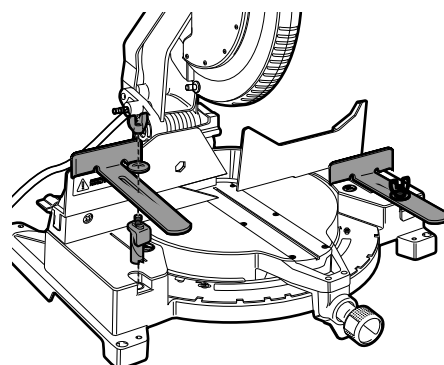

Every B&D tool is of the highest quality.

If you wish to contact us regarding this product, please call toll free between 8:00am and 8:00pm ET, seven days a week:

1-800-9-BD TOOL
(1-800-923-8665)

IMPORTANT!

To assure product safety and reliability, particularly for Double Insulated tools, repairs, maintenance and adjustment (excluding maintenance described in this manual) should be performed by B&D service centers or authorized service centers, using identical B&D replacement parts.

One Year Service/Safety Check

All B&D tools for Industry and Construction are covered under a service/safety check program where B&D will inspect your tool for safety and provide necessary maintenance or repairs, including normal wear and tear parts, for one year, FREE OF CHARGE.

Full Warranty

All B&D tools for Industry and Construction are warranted to be free of any defects in materials or workmanship. Upon thorough examination of tool, B&D will repair or replace, at our option, any product that is determined to be defective.

Conditions

The service/safety check and the warranty do not apply to: repairs made or attempted by anyone other than an authorized B&D service location; misuse, abuse, neglect, improper application of the tool; missing parts; or normal wear and tear (after first year of ownership). Please return the complete unit, transportation prepaid, to any B&D factory owned or B&D authorized service center location (list provided with tool or see Yellow Pages under "Tools Electric").

These symbols on the nameplate mean the product is listed by Underwriter's Laboratories, Inc. and certified by the Canadian Standards Association.



Black & Decker (U.S.) Inc. • 701 East Joppa Road, Towson, Maryland 21286

Printed in U.S.A. (JAN94-CD-1) Form No. 159185 Copyright © 1994