



ATD-10535

7 AMP Variable Speed Reciprocating Saw

Owner's Manual



Manufactured in China
To ATD Tools, Inc. Specifications

TECHNICAL SPECIFICATIONS

Voltage: 120V

Frequency: 60Hz

Power input: 7 Amps

No load speed: 600-2400/min

Max. Cutting thickness: 5.9"

Stroke length: 1-3/16"

Weight: 8.8 lbs

Lpa (sound pressure level): 90.2dB(A)

Lwa (sound pressure capacity): 103.2dB(A)

Vibration value: 10,675 m/s

PRODUCT INFORMATION

1. Blade
2. Footplate
3. Blade clamp screw
4. Trigger switch
5. Speed controller
6. Trigger lock button
7. Mains lead
8. Footplate length adjustment screws

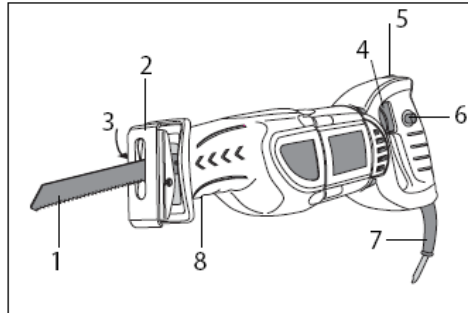

Fig.A

SAFETY INSTRUCTIONS

The following pictograms are used in these instructions:



There is danger of material damage or bodily injury.



There is a chance of electric shock.



The tool meets the safety requirements stated in the applicable European guidelines.



Class II equipment – Doubly insulated – A grounded plug is not necessary

Carefully read this manual before using the ATD10535 reciprocating saw. Make sure that you know how the saw functions and how to operate it. Maintain the saw in accordance with the instructions to make sure it functions properly. Keep this manual and the enclosed documentation with the saw. When using electric tools always observe the safety regulations applicable in your country to reduce the risk of fire, electric shock and personal injury. Read the following safety instructions and also the enclosed safety instructions. Keep these instructions in a safe place.

ADDITIONAL SAFETY INSTRUCTIONS

The ATD-10535 reciprocating saw must not be damp and must not be operated in a wet environment. Always inspect cable and plug before using the saw. Only have damage repaired by a qualified professional. Only plug the saw into the main wall socket when the tool is switched off. Wear protective gloves and sturdy footwear. **DO NOT SAW MATERIALS CONTAINING ASBESTOS!!!**

- Wear protective goggles at all times.
- Wear a protective mask when sawing any fibrous materials.
- Portable equipment used outdoors must be connected with a fault-current circuit breaker.
- Extension cables and plugs must be approved for outdoors.
- Remove adjusting keys and wrenches before turning the tool on.
- Secure your work piece with clamps. Always lead electrical cord away from tool towards the rear.
- When tool is switched on, be sure to move it towards the work piece only.
- Always hold tool with both hands and ensure that you have a safe footing while working.
- Only operate this saw with the foot plate mounted. When sawing, the foot plate must always rest on the work piece.
- Always unplug the saw from the main wall socket before attempting any work on it.
- Do not carry the tool by the electrical cord.
- Incorrect handling may damage the tool. Therefore always comply with the instructions.
- Use only sharp saw blades in perfect condition; replace cracked, distorted or blunt saw blades immediately.
- Tool should only be switched on with blade installed
- Select tools, stroke rate and pendulum actions according to material, Take care to maintain a constant feed rate.
- Do not attempt to stop the saw blade with lateral pressure after switching off.
- Only use genuine ATD repair parts.
- Always use the correct supply voltage. The voltage specifications on the rating plate must correspond with the main voltage.

IMMEDIATELY SWITCH OFF THE TOOL IF THE FOLLOWING CONDITIONS EXIST:

- Excessive sparking of the carbon brushes in the collector.
- Interruption in the main power, main lead or main lead damage.
- Switch is faulty.
- Smoke or smell of scorched or burnt insulation.

ELECTRICAL SAFETY

 Always check that the power supply corresponds to the voltage on the rating plate.

 Your tool is double insulated in accordance with EN 50144; therefore no ground wire is required. When replacing cable or plug, immediately throw away old cables or plugs. It is dangerous to insert the plug of a loose cable in the wall outlet. When using extension cables only use an approved extension cable suitable for the power input of the tool. When using a cable reel always unwind the reel completely.

OPERATION

 CHANGING/FITTING THE BLADE

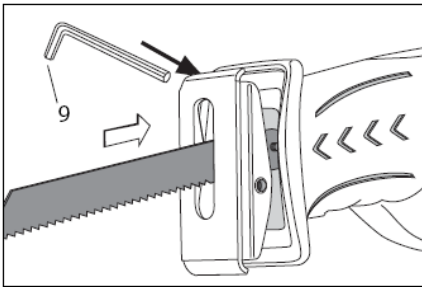

Fig.B

- Be sure the tool is unplugged.
- Loosen the blade lock screw with the 4mm hexagon key.
- Insert the saw blade between the stroke rod and the clamping plate.
- Take care that the securing pin of the stroke rod engages in the hole of the saw blade. (Saw blade cannot be pulled out).
- Retighten the blade lock screw.
- When changing the saw blade, make sure that the blade holder is free of material residue (e.g. wood or metal shavings),
- Before plugging the saw into the wall outlet, double check to be sure the saw blade is secure.

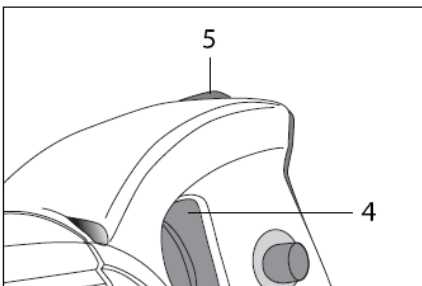

Fig.C

Make sure that the saw blade does not rest on or touch any objects when the tool is switched on.

Switching on

- Pull the on-off trigger switch (4).

Switching off

- Release the on-off trigger switch.
- The on-off trigger switch can be locked on for continuous operation by pressing the trigger lock button while pulling the trigger.
- To release the trigger lock, simply pull the trigger switch again.

SPEED CONTROL

- During operation and while the tool is at rest the stroke rate (speed) can be selected using the thumbwheel (5). The stroke rate will remain constant even under load.
- The stroke rate required depends upon the material conditions. The optimal setting should be determined in use.
- After working for longer periods at low speed you should allow the tool to cool down by running it at maximum speed with no-load for approx. 3 minutes.

ADJUSTING THE FOOT PLATE ANGLE

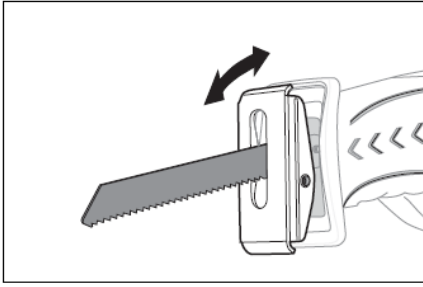

Fig.D

- To allow the foot plate to securely rest on the work piece, the angle of the footplate can be adjusted as shown in the diagram.
- The footplate can also be extended by loosening the two footplate length adjustment screws using the 4 mm hexagon key and then pulling the footplate out to the required length. Ensure the footplate adjustment screws are secure before resuming work.

SAWING TIPS

- Adjust saw blade and stroke rate to suit the material to be processed. For tight radius curves it is best to use a narrow saw blade.
- Apply coolant or lubricant to alleviate the heat produced when sawing metal.
- Check wood, chip boards, building materials etc, for foreign bodies (nails, screws etc.), before sawing and remove them, if necessary.
- Clamp material well. Do not support the work piece with hand or foot.
- Do not touch objects or the floor with the saw running (danger of backlash).
- **DO NOT SAW MATERIAL CONTAINING ASBESTOS!**
- Put the footplate on the surface of the work piece and saw through it with constant contact pressure or feed.
- If the saw blade seizes switch the tool off immediately. Spread the gap with a suitable tool and pull out the saw blade.
- After finishing work, switch off the tool and only put it down after it has come to a complete standstill.

PLUNGE CUTTING

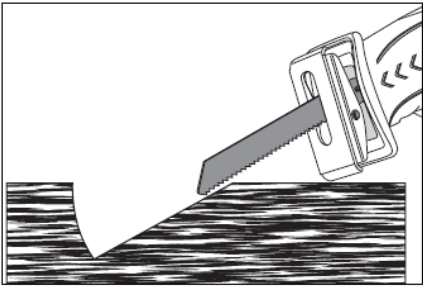

Fig.E

- Plunge cutting may only be used on soft materials such as wood, aerated concrete, gypsum plaster boards, etc.
- Plunge cutting requires a certain practice and is only possible with short saw blades.
- Place the saw onto the work piece and switch it on.
- Ensure that the bottom edge of the footplate rests on the work piece surface as shown in figure E above.
- Slowly saw into the work piece at an angle, moving the saw to a vertical position and continue to saw along the cutting line.
- Switch the saw off and lift off the work piece when the work is complete.

FLUSH SAWING

- Elastic bi-metal saw blades allow you to saw projecting objects (e.g., water pipes, iron bars, etc.) flush against the wall.
- Apply the saw blade directly to the wall and bend slightly so that the footplate rests against the wall.
- Switch the tool on and saw off the work piece keeping constant lateral pressure against the wall.

TROUBLESHOOTING

There are no user serviceable parts in this unit. Any repairs or servicing should be carried out by qualified service engineers. If you are having problems with your tool, below are a few common solutions:

1. The electromotor gets hot:

- The cool ventilation slots in the motor are stopped up with dirt. - Clean the cool ventilation slots.
- The motor is defective. - Have your tool repaired or checked by your local ATD dealer.

2. Tool does not work when hooked up to power.

- Interruption in the mains connection. - Check circuit breaker and/or try another electrical appliance in same outlet.
- Cut cord. – Unplug tool from power and check the power cord for cuts or frays. **DO NOT USE UNTIL CORD IS REPAIRED.**

3. Blade is rattling or not cutting normally.

- Blade is loose or worn. – Unplug tool and check condition of blade and ensure that the blade locking screws are tight

MAINTENANCE

Make sure that the tool is not live or plugged in when carrying out maintenance work on the motor.

This tool has been designed to operate over a long period of time with a minimum of maintenance.

Continuous satisfactory operation depends upon proper tool care and regular cleaning.

Cleaning

Keep the ventilation slots of the tool clean to prevent overheating of the motor. Regularly clean the tool housing with a soft cloth, preferably after each use. Keep the ventilation slots free from dust and dirt. If the dirt does not come off use a soft cloth moistened with soapy water. Never use solvents such as gasoline, alcohol, ammonia, etc. These solvents may damage the plastic parts.

Lubrication

The tool requires no additional lubrication.

Replacing the Carbon Brushes

Refer to the Parts Diagram on the last page of this manual and figures below.

1. Unscrew the screws (#47) on both sides of the handle. Make sure the screws are kept in a place that you can easily find them. Carefully separate the handle from the saw body, taking care not to pull the wires from the motor. After you take off the lower handle, you will see the holes under the brush holders. (Fig. 1) Use screwdriver or similar tool to push the brush holder through the holes from the bottom, making sure that you catch the parts as they are pushed out from the other side. The spring on the brush will cause the brush cap and possibly the brush itself to be lost if you don't cover them up as you remove them. Make note of how the brushes, brush holders, brush caps and wires are assembled before removal. **CAUTION:** The brush holders are tightly assembled inside. Be careful not to force things when removing them to avoid damaging the brush holders.

2. Take the worn carbon brushes out and slide the new replacement brushes into the brush holder (#42). The terminal connected to the wire (Fig.1) should be placed to contact the copper piece of the carbon brush as it was disassembled. After the contact wire is in place making contact with the copper piece on the brush, replace the brush cap (#44) and hold the assembly together and carefully insert it back to its original place (Fig.3).

Note: To avoid the spring tension pushing everything apart when reassembling, insert the brush holder with the brush cap side first and then slowly push the whole brush holder back.

Fig.1



Fig.2



Fig.3



When installing the brush holder with the replacement brushes back into the tool, be sure the cords, wires and switch are placed correctly as shown in Fig 3.

FAULTS

Should a fault occur, e.g. after wear of a part, please contact the place you purchased this tool. In the back of this manual you find an exploded view showing the parts that can be ordered. It is recommended that the tool only be repaired by an experienced technician.

ENVIRONMENT

In order to prevent the tool from damage during transport, it is delivered in a sturdy packaging. Most of the packaging materials can be recycled. Take these materials to the appropriate recycling locations.

WARRANTY

The ATD-10535 variable speed reciprocating saw has a 1 year warranty against manufactures defects in workmanship and materials. In the event of a warranty claim, return the tool to the place of purchase along with your invoice, receipt or other dated proof of purchase for a repair, replacement or refund which is left to the proprietor's discretion.

The manufacturer declares under their sole responsibility that this product is in conformity with the following standards or standardized documents EN50144-1, EN50144-2-11, EN55014-1, EN55014-2, EN61000-3-2, EN61000-3-3, In accordance with the regulations 98/37/EEC, 73/23/EEC, 89/336/EEC from 01-09-2004.



ATD-10535

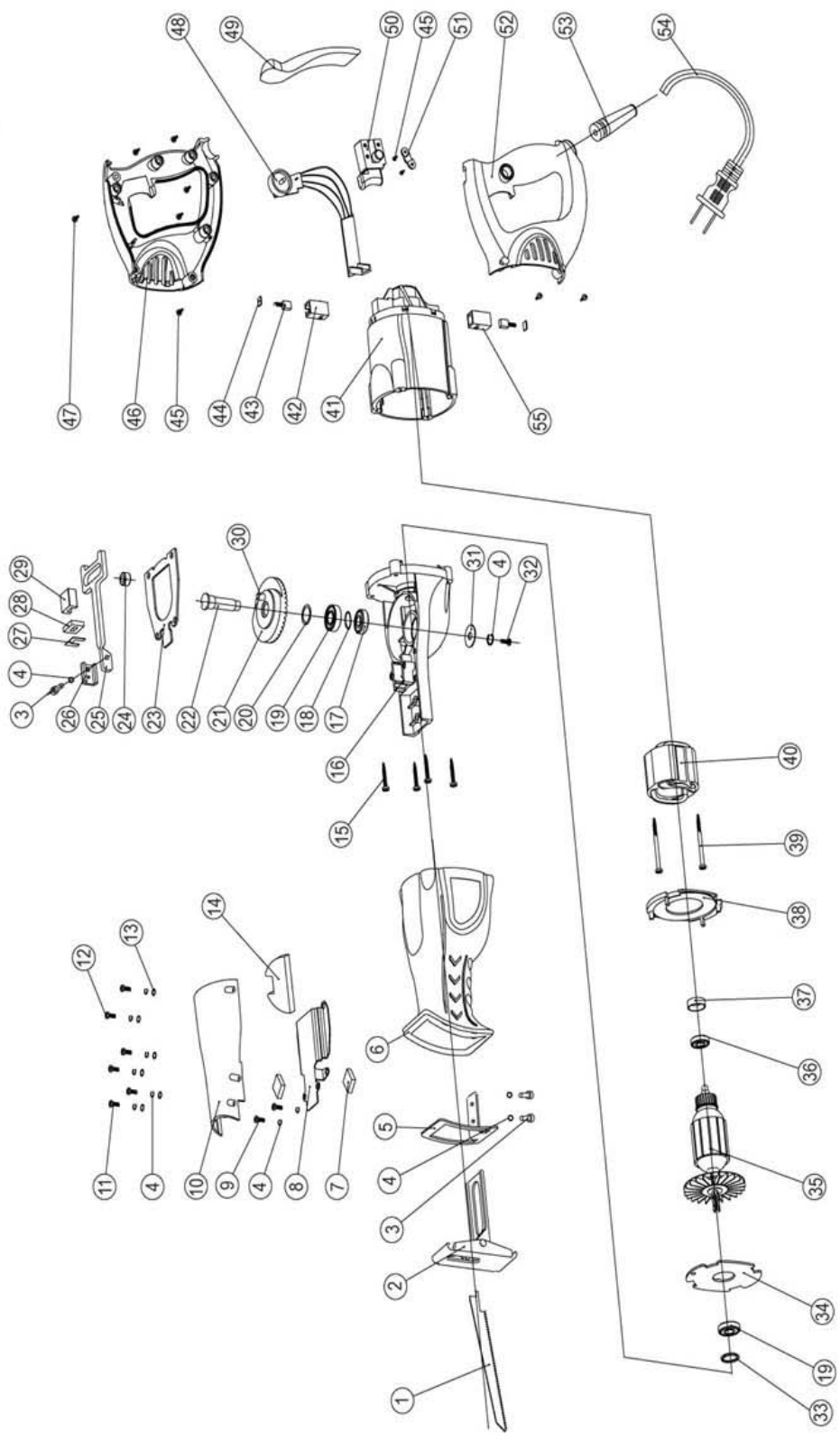



ATD-10535

ITEM#	ORDERING PART#	DESCRIPTION
1	PRT10535-01	SAW BLADE
2	PRT10535-02	SHOE
3	PRT10535-03	HEX SCREW
4	PRT10535-04	SPRING WASHER
5	PRT10535-05	SHOE COVER
6	PRT10535-06	INSULATION COVER
7	PRT10535-07	FELT
8	PRT10535-08	PROTECTING COVER
9	PRT10535-09	SCREW
10	PRT10535-10	GEAR HOUSING COVER
11	PRT10535-11	SCREW
12	PRT10535-12	SCREW
13	PRT10535-13	FLAT WASHER
14	PRT10535-14	FELT
15	PRT10535-15	SCREW
16	PRT10535-16	GEAR HOUSING
17	PRT10535-17	BALL BEARING
18	PRT10535-18	CIRCLIP
19	PRT10535-19	BALL BEARING
20	PRT10535-20	FLAT WASHER
21	PRT10535-21	LARG GEAR
22	PRT10535-22	SHAFT
23	PRT10535-23	MIDDLE COVER
24	PRT10535-24	NEEDLE BEARING
25	PRT10535-25	RECIPROCATING BAR
26	PRT10535-26	BLADE CLAMP
27	PRT10535-27	SQUARE WASHER
28	PRT10535-28	FELT

ITEM#	ORDERING PART#	DESCRIPTION
29	PRT10535-29	SLIDING BEARING
30	PRT10535-30	PIN
31	PRT10535-31	WASHER
32	PRT10535-32	SCREW
33	PRT10535-33	CIRCLIP
34	PRT10535-34	BEARING SEAT
35	PRT10535-35	ARMATURE
36	PRT10535-36	BALL BEARING
37	PRT10535-37	BEARING COVER
38	PRT10535-38	BAFFLE
39	PRT10535-39	SCREW
40	PRT10535-40	FIELD
41	PRT10535-41	HOUSING
42	PRT10535-42	BRUSH HOLDER (RIGHT)
43	PRT10535-43	CARBON BRUSHES
44	PRT10535-44	BRUSH CAP
45	PRT10535-45	SCREW
46	PRT10535-46-52	HANDLE SET
47	PRT10535-47	SCREW
48	PRT10535-48	SPEED SWITCH
49	PRT10535-49	RUBBER GRIP
50	PRT10535-50	SWITCH
51	PRT10535-51	CABLE CLAMP
52	PRT10535-46-52	HANDLE SET
53	PRT10535-53	GUARD CORD
54	PRT10535-54	POWER CORD
55	PRT10535-55	BRUSH HOLDER (LEFT)