

***JEROME*[®] 631-X[™]**
HYDROGEN SULFIDE ANALYZER
Operation Manual

January 2003

Arizona Instrument LLC
1912 W 4th Street
Tempe, AZ 85281

(800) 528-7411

(602) 470-1414

Fax (480) 804-0656

<http://www.azic.com>

email:

azi@azic.com - General

intl@azic.com - International

support@azic.com - Customer Support

700-0037-A

JEROME 631-X

Hydrogen Sulfide Analyzer

Operation Manual



PROPRIETARY RIGHTS NOTICE

This manual contains valuable information and material developed by Arizona Instrument LLC for use with the Jerome 631-X Hydrogen Sulfide Analyzer. No part of this manual can be reproduced or transmitted in any form or by any means, electronic, mechanical or otherwise. This includes photocopying and recording or in connection with any information storage or retrieval system without the express written permission of Arizona Instrument LLC.

ALL RIGHTS RESERVED

© Copyright 2003, Arizona Instrument LLC
Resisorb™ is a registered trademark of J.T. Baker Chemical Company.
Tygon™ is a registered trademark of Norton.

Table of Contents

1. FOR THOSE WHO CAN'T READ THE WHOLE MANUAL NOW	4
2. INTRODUCTION	6
3. PRINCIPLE OF OPERATION.....	7
Zero Air Filter	8
Gas Flow Schematics.....	8
4. INSTRUMENT OPERATION	10
LCD Codes	10
Daily Operations.....	11
Sensor Regeneration	12
Zero Adjust.....	13
Sample Mode.....	14
Survey Mode	15
Operating on AC Power or Generator	16
Operating on Internal Battery Power	16
External battery power.....	16
Charging Batteries	17
Obtaining Maximum Battery Life	17
5. MAINTENANCE.....	18
Preventive Maintenance Calendar	18
Flow System	19
.25 inch Fritware Filter	19
Internal Filters	20
Replacing the Battery Pack.....	21
Setting the Input Voltage.....	21
Changing the Fuse	22
6. CALIBRATION.....	23
Verification of Calibration and Quality Control	23
7. 631-X TROUBLESHOOTING	24
8. JEROME 631-X TECHNICAL SPECIFICATIONS	27
Optional Communications Capability.....	28
Instrument I/O Interface	28
9. ACCESSORIES & MAINTENANCE PARTS.....	30
Spare Parts	32
10. FACTORY CALIBRATION SERVICE.....	35
11. APPENDIX A - 631-X FUNCTIONAL TEST MODULE.....	36
Simple Operation.....	36
12. APPENDIX B - JEROME COMMUNICATIONS SOFTWARE.....	37
Instrument Control with Real-Time Graphics	37
JCI Kit Contents	38
System Requirements	38
Data Logger Option.....	38
13. APPENDIX C - INTERNAL DIP SWITCH SETTINGS.....	39
DIP Switch Settings:.....	39
14. APPENDIX D - JEROME 631-X OPTION BOARD.....	40
Auto-Zero	40
Instrument Zeroing	40
Timed Regeneration	41
Auto-Sample.....	42
4-20 MA Analog Output.....	42
SW101 Functions:	42
Connection and Setup:	43
Fresh Air Solenoid.....	45
DC Power Operation	46
DC Power Adaptor Kit, AZI P/N Y031-0902.....	46
15. APPENDIX E: CALCULATION OF DYNACALIBRATOR H₂S CONCENTRATION	48
16. WARRANTY	49

1. FOR THOSE WHO CAN'T READ THE WHOLE MANUAL NOW

This manual contains details that will optimize the results and the life of your instrument. Read and refer to the manual for complete details on operation, maintenance and troubleshooting, special voltage inputs and data output.

The Jerome 631-X is easy to operate and ready for use upon receipt from the factory.

- Remove the instrument from the packing material.

Retain all packaging materials for any future shipment of the instrument.

If the instrument is returned to AZI for any reason, it must be placed in the original packaging materials that have been tested and proven to be effective protection during shipment.

- Call AZI Customer Service at 800-528-7411 or 602-470-1414 for Return Material Authorization (RMA) information prior to returning a unit.
- For all shipments, boxes and packing materials are available from AZI.
- Pack the Jerome instrument only in a Jerome shipping container.

AZI WILL NOT BE RESPONSIBLE FOR SHIPPING DAMAGE. IF YOU RETURN THE INSTRUMENT IMPROPERLY PACKAGED OR SHIPPED, YOU SHOULD INSURE IT FOR FULL VALUE.

- Check for any damage and confirm receipt of all parts on your packing list. Contact Arizona Instrument Customer Service at (800) 528-7411 or (602) 470-1414 if you have any questions.
- Press the ON button. The display should read 000 in less than one second.
 - A LO BAT message appears briefly in the upper left corner.
 - If the LO BAT light persists, recharge the battery. See page 17.

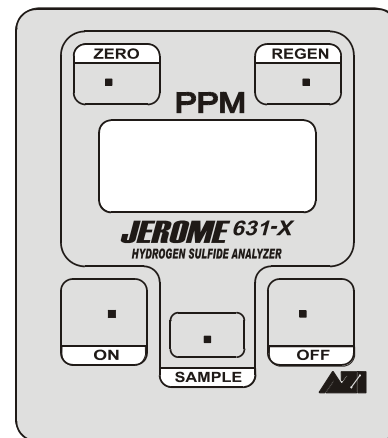

- Check the voltage setting (110 or 220 VAC) on the back of the instrument. Ensure that it is set to the correct voltage. If the pointer is not aligned to the local voltage, turn the selector to point to the correct voltage.
- Perform a sensor regeneration by following these steps:
 - Connect the line cord between the connector on the back of the 631-X and an AC power outlet.
 - Press the ON switch and then press the REGEN button.
 - ◆ The instrument will begin a 10 minute regeneration cycle, indicated by .H.H.H flashing on the display. **Do not interrupt this cycle.** For a complete description of this process, see page 12.
 - ◆ If any error message, such as .P.P.P, appears on the display, see the “Troubleshooting” section beginning on page 24.
- When regeneration is complete, zero the sensor by pressing the ZERO button and turning the zero adjust screw, located under the handle, until the display reads 0.
- The instrument is now ready to sample.
- To ensure the input to the instrument contains no hydrogen sulfide or mercaptans, use a Zero Air Filter, AZI P/N Z2600 3905. The Zero Air Filter cleans the air sample and should produce sample readings of less than 0.003 mg/m³. Therefore, use the filter to:
 - Equilibrate the instrument to temperatures that are higher or lower than the instrument. Sample with filter installed until the reading is below 0.003 mg/m³.
 - Identify contamination within the unit.
 - Confirm the presence of hydrogen sulfide when readings are elevated. Install filter and verify that the readings go down with filter installed.
- When the instrument measures hydrogen sulfide, the zero display will be replaced with H.

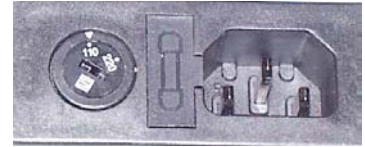

CAUTION

Do not adjust the ZERO after the instrument has measured hydrogen sulfide or before the next regeneration. (Occasionally the display may drop to .L.L.L (indicating low) between the initial zeroing and the first sample. It is OK to readjust the ZERO if the instrument has not measured hydrogen sulfide.)



- The instrument is designed for ambient air monitoring. **DO NOT allow the probe or the instrument’s intake to be exposed to any liquid.**
- The instrument is not explosion proof.
- Press the SAMPLE button to start a 10 second sampling cycle.
- Perform sensor regeneration after each day’s testing.
- Perform another sensor regeneration and re-zero the instrument before each day’s use.
- Perform sensor regeneration after 30 days of storage or inactivity.

Call AZI Customer Service, at (800) 528-7411 from the United States and Canada or (602) 470-1414 if you have any questions. If you prefer, you may send e-mail to support@azic.com

2. INTRODUCTION

The Jerome 631-X Hydrogen Sulfide Analyzer is an ambient air analyzer with a range of 0.003 ppm to 50 ppm (parts per million).



CAUTION:

The Jerome 631-X is for vapor use only.
DO NOT allow the probe or the instrument's intake to be exposed to any liquid, dust or other foreign material.



The 631-X is designed to be easy to operate for quick and accurate analysis of hydrogen sulfide vapor levels. It has few maintenance requirements. However, please take a moment to read this manual before attempting operation. If you have any questions about your application or operation, please call AZI Customer Service at (800) 528-7411 or (602) 470-1414 or e-mail support@azic.com for assistance.

631-X Features

- Accurate analysis of hydrogen sulfide in seconds
- Wide detection range allows multiple applications
- Survey mode for rapid source detection of hydrogen sulfide concentrations
- Rechargeable internal battery pack for portability
- Automatic backlight for LCD during low light conditions
- Microprocessor ensures a linear response throughout the entire range of the sensor
- Inherently stable gold film sensor

Optional Accessories

- Data Logger, P/N Y6100 0057, to record field monitoring information
- Jerome Communication Software Kit, P/N Y6100 0054, for unattended fixed-point sampling and downloading information from the data logger to a computer.
- Option Board (factory installed option) for external fresh air solenoid support, auto-zeroing, DC power operation, timed regeneration, 4-20 mA or 0-2 V analog output, and timed sampling
- Functional Test Module (FTM) and Accessory Kit, P/N Z2600 0918 and Y2600 0902, for sensor calibration verification in the field
- Field Carrying Cases, hard sided P/N Y411 0904 or soft P/N 1400 0052, for versatile handling and additional storage
- Maintenance Kit, P/N Y631 0905 for routine maintenance and upkeep

Applications

- Ambient air analysis
- Odor nuisance monitoring
- Regulatory compliance
- Control room corrosion monitoring
- Quality control
- Scrubber efficiency testing
- Accuracy check for other hydrogen sulfide monitors and control systems
- Hydrogen sulfide source detection
- Leak detection
- The Jerome 631-X can be operated from 100-120 or 200-240 VAC. To change the default voltage range, refer to “Setting the Input Voltage” on page 21.

3. PRINCIPLE OF OPERATION

A thin gold film, in the presence of hydrogen sulfide, undergoes an increase in electrical resistance proportional to the mass of hydrogen sulfide in the sample.

When the SAMPLE button is pressed, an internal pump pulls ambient air over the gold film sensor for a precise period. The sensor absorbs the hydrogen sulfide. The instrument determines the amount absorbed and displays the measured concentration of hydrogen sulfide in ppm. During normal sampling, the ambient air sample is diluted in the flow system at a ratio of 100:1. When sampling in Range 0, (where low levels of hydrogen sulfide are expected) undiluted air samples are drawn across the gold film sensor.

The instrument's microprocessor automatically re-zeroes the digital meter at the start of each sample cycle and freezes the meter reading until the next sample cycle is activated, thus eliminating drift between samples.

During the sample mode cycle, bars on the LCD represent the percentage of sensor saturation. Depending on the concentrations, 50 to 500 samples may be taken before the sensor reaches saturation. At that point, a 10-minute heat cycle must be initiated to remove the accumulated hydrogen sulfide from the sensor. During the sensor regeneration cycle, both solenoids are closed to cause air to pass through a scrubber filter and provide clean air for the regeneration process. The flow system's final scrubber filter prevents contamination of the environment.

The heat generated during the regeneration may cause some low level thermal drift. To ensure maximum sample accuracy, wait 30 minutes after regeneration before zeroing and using the instrument.

Zero Air Filter

The Zero Air Filter removes mercury vapor, mercaptans, and hydrogen sulfide from the air sample. Readings with the filter installed should be near zero.

Because air that is cooler than the instrument will cause low readings and warmer air will cause higher readings, the Zero Air Filter should be used to equilibrate the unit to ambient air. Continuous sampling with clean air will not cause saturation of the gold film sensor but will equalize temperatures faster to allow accurate analysis to begin sooner.

The Zero Air Filter can also be used to identify contamination within the instrument. If the readings do not reduce to near zero with the filter installed, contamination should be suspected. If the readings do drop to near zero with the filter installed but elevate with the filter removed, the presence of hydrogen sulfide at the sampled location is confirmed.

For more information on the use of the Zero Air Filter, contact customer service at 1-800-528-7411, 1-602-470-1414, or visit our web site at <http://www.azic.com>.

Gas Flow Schematics

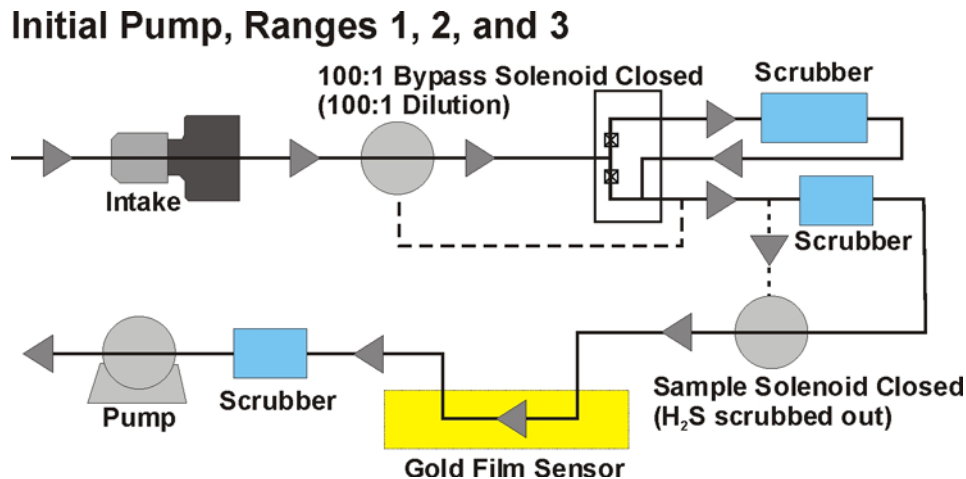

Sample Period, Ranges 1, 2, and 3

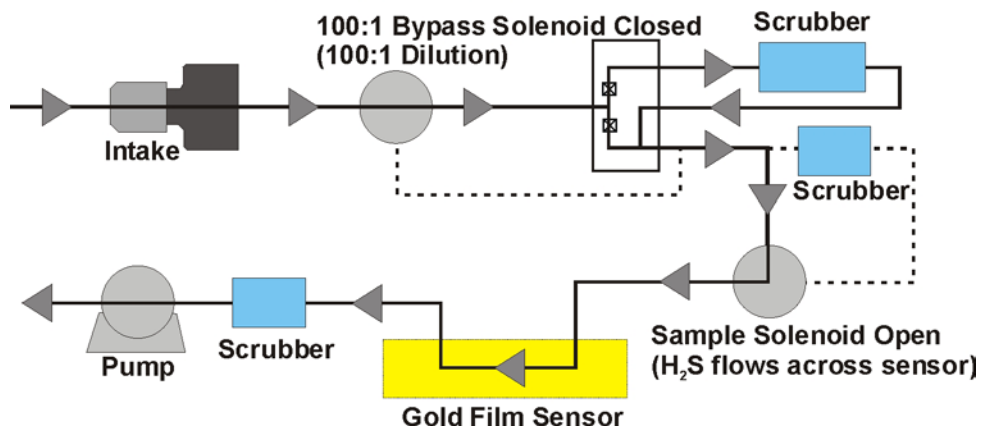

Initial Pump, Ranges 0

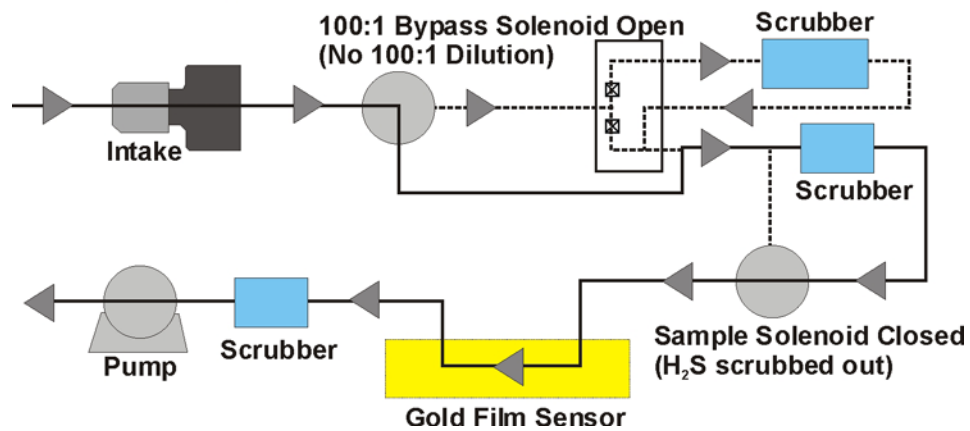

Sample Period, Ranges 0

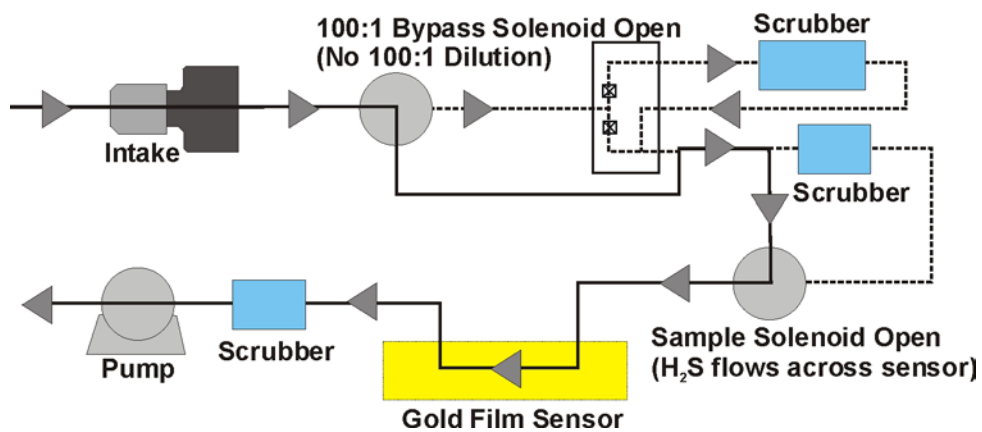

4. INSTRUMENT OPERATION

LCD Codes

LCD CODE	EXPLANATION
000	Ready to sample
.000	No hydrogen sulfide reading
.8.8.8	Sensor saturated-regeneration needed (refer to page 12)
.H.H.H	Sensor regeneration in progress (.H.H.H flashes)
.L.L.L	Re-zero needed (refer to page 13)
.P.P.P	Power cord required or low line power, <100 VAC (or 200 VAC) (see pages 16 and 17, Changing the Fuse, if .P.P.P remains on after the cord is connected.)
.LO BAT	Recharge batteries (refer to page 17)
.E.E.E	Same as LO BAT, automatically shuts off
.HL	Very high concentration has been detected. Refer to your safety policy for additional direction to confirm the concentrations."
DURING SAMPLING	
.-	0-25% sensor saturation
.--	25-50% sensor saturation
.-.-	50-75% sensor saturation
-.---	75-100% sensor saturation
DURING SAMPLING, USING SURVEY MODE	
-	Survey sampling (minus sign flashes continuously)
WHEN ZERO IS DEPRESSED	Adjust to 0 <u>only</u> after sensor regeneration. It is normal for the display to read H after sampling has started.
0	Zero, ready to sample
H	High, turn Zero potentiometer counterclockwise
L	Low, turn Zero potentiometer clockwise

Daily Operations

Before each day's use of the Jerome 631-X, perform the following steps to verify proper instrument operation:

- Press the power ON button.
 - The digital meter displays 000.
 - ◆ (Disregard the digital meter's initial momentary reading.)
 - ◆ Recharge or replace the battery pack if the LO BAT indicator REMAINS ON. Refer to “Charging Batteries” on page 17 and/or “Replacing the Battery Pack” on page 21.
 - ◆ To ensure the instrument's electronics have stabilized, allow a 1-minute warm up before beginning the next step.
- Use the Zero Air Filter to equilibrate the instrument to ambient air temperature.
 - Install the Zero Air Filter in the instrument's intake.
 - Sample continuously until the readings stabilize.
- Perform sensor regeneration. Refer to page 12 for the procedure.
- Thirty minutes after sensor regeneration is complete, zero the instrument. See page 13.

NOTE: For maximum accuracy, such as when testing with the Functional Test Module, wait 30 minutes after the sensor regeneration cycle to re-zero the unit. For immediate use, the unit can be re-zeroed immediately after sensor regeneration. See the notes on page 13.

- Press the SAMPLE button.
 - During the sample cycle, the digital meter displays bars (-, --, or ---) to indicate the amount of sensor saturation.
- At the end of the sampling cycle, read the digital meter.
 - The number shown on the digital meter is the hydrogen sulfide concentration in ppm.
 - This value remains on the display until the next sample is taken.
 - The digital meter automatically zeroes at the start of each sample.
- At the end of each day's use, perform sensor regeneration as described in the next section.

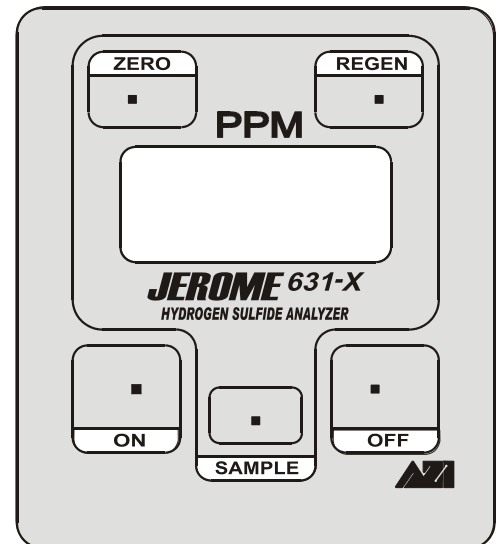

DO NOT ALLOW HYDROGEN SULFIDE TO STAY ON THE GOLD FILM SENSOR OVERNIGHT.

Sensor Regeneration

Sensor regeneration is needed to clear the 631-X sensor of any accumulated hydrogen sulfide. This simple procedure should be done:

- At the beginning of the day on which the instrument is to be used.
- During the day when the sensor becomes saturated.
- At the end of the day before storing the instrument.



CAUTION:

Ensure the voltage selector on the back of the instrument, near the power cord inlet connector, points to the local AC power value. See “Setting the Input Voltage” on page 21.

To clean and protect the sensor, the supplied AC power must be 100 to 120 VAC or 220 to 240 VAC, depending on the available power source.

Once sensor regeneration is initiated, DO NOT interrupt the cycle.



- Attach the power cord to the 631-X and plug it into AC power. AC power is required to thermally regenerate the sensor.
- Press the power ON button.
- Press the REGEN button.
 - The digital meter flashes .H.H.H for the duration of the 10-minute cycle and displays .0.0.0 when the cycle is completed.

DO NOT INTERRUPT THIS CYCLE.

Wait until the cycle is completed before continuing with the next step.

- A minimum 30-minute wait after the sensor regeneration cycle is complete ensures maximum sample accuracy. However, the unit can be used immediately following the sensor regeneration if necessary. When the sensor regeneration is complete, press ZERO and adjust the ZERO ADJUST pot until 0 appears on the display. Install the zero air filter in the intake and take several samples or lock the instrument into survey mode (see page 12). After approximately one minute, stop sampling and check the ZERO. Adjust to 0. Repeat sampling through the zero air filter until reading remains on 0.

NOTE: The digital meter will read .P.P.P after REGEN is activated if the power cord is not plugged in or if the instrument's fuse needs to be replaced. Connect the power cord, or if necessary, replace the fuse. See “Changing the Fuse” on page 22.

Zero Adjust

- To ensure air entering the instrument is clean, install the aero air filter in the instrument's intake and sample until the readings stabilize.
- While pressing the ZERO button, turn the ZERO ADJUST potentiometer (shown at right) using the trimmer tool until the digital meter reads 0.
 - If the LCD reads H, turn the ZERO ADJUST counter-clockwise;
 - If the LCD reads L, turn the ZERO ADJUST clockwise.



NOTE: A minimum 30-minute wait after the sensor regeneration cycle is complete ensures maximum sample accuracy. The unit can be used immediately following the sensor regeneration if necessary. When the sensor regeneration is complete, press ZERO and adjust the ZERO ADJUST pot until 0 appears on the display. Install the zero air filter in the intake and take several samples or lock the instrument into survey mode (see page 15). After approximately one minute, stop sampling and check the ZERO. Adjust to 0 if necessary. Repeat sampling through the zero air filter until sensor remains on 0.

NOTE: When ZERO is pressed, and depending upon internal configuration, a number between 00 and 100 may appear on the display instead of H, L, or O. See “APPENDIX C - INTERNAL DIP SWITCH SETTINGS”, on page 39, for details.

CAUTION:

Do not turn the ZERO ADJUST potentiometer between samples.

Turn the ZERO ADJUST only after a sensor regeneration cycle otherwise invalid readings will result.

- Press the power OFF button and disconnect the power cord.
- The Jerome 631-X is ready for sampling.

CAUTION:

The Jerome 631-X is intended for vapor use only. DO NOT allow the probe or the instrument's intake to be exposed to liquids, dust or other foreign material. Moisture or liquids drawn into the instrument can damage the sensor and flow system.

Sample Mode

This is the standard operation mode and is used for optimum accuracy.

- Press the power ON button.
 - The LCD displays 000.
 - Disregard the LCD's initial momentary readings.
 - Recharge or replace the battery pack if the LO BAT indicator REMAINS ON, see page 17 and/or page 21 if necessary.
- Allow a 1-minute warm up before beginning the next step to ensure the instrument's electronics have stabilized.
- Press the SAMPLE button.
 - During the sampling cycle, the bar (or bars) shown on the LCD indicates the current percentage of sensor saturation. (Refer to “LCD Codes” on page 10 for code descriptions.)
 - The length of the sample cycle depends on the concentration of hydrogen sulfide.

RANGE	CONCENTRATION	RESPONSE TIME	ACCURACY at MID-RANGE
0	0.001 to 0 .099 ppm	30 Seconds	± 0.003ppm at 0.050ppm
1	0.10 to 0.99 ppm	25 Seconds	± 0.03ppm at 0.50ppm
2	1.0 to 9.9 ppm	16 Seconds	± 0.3ppm at 5.0ppm
3	10 to 50 ppm	13 Seconds	± 2ppm at 25ppm

- At the end of the sampling cycle, read the LCD.
 - The number shown on the digital meter is the hydrogen sulfide concentration in ppm.
 - As the instrument auto-ranges, the decimal point moves to the correct position to show the concentration.
 - The value remains displayed until the next sample is taken. The digital meter will then automatically zero before displaying the next sample value.
 - When elevated readings are detected:
 - ◆ Confirm the reading by taking an additional sample.
 - ◆ Install the zero air filter and verify that the readings reduce to zero or very near zero.
 - ◆ Remove the filter and sample the location again to verify that elevated reading do exist.
 - When the sensor is completely saturated, the LCD displays .8.8.8 instead of a value. No further operation is possible until sensor regeneration is performed. (Refer to “Sensor Regeneration” on page 12.)
- Press the power OFF button when not in use.

Note: The Jerome 631-X operates approximately six (6) hours on a fully charged battery.

Survey Mode

The survey mode takes samples every 3 to 20 seconds automatically. The length of time varies with the hydrogen sulfide concentration. Use this mode to locate the source of hydrogen sulfide, such as a leak, a hot spot, or to assess areas of potentially high hydrogen sulfide concentrations. After the survey mode is activated, the 631-X samples continuously.

- Press the power ON button.
 - The digital meter displays 000.
 - Disregard the LCD's initial momentary readings.
 - Recharge or replace the battery pack if the LO BAT indicator REMAINS ON, see page 17 and/or page 21 if necessary.
- Allow a 1-minute warm up before beginning the next step to ensure the instrument's electronics have stabilized.
- Lock the instrument in the survey mode:
 - Hold the SAMPLE button down until the sensor status indicator bar(s) begin flashing on the display.
 - Press the ZERO button, then release the SAMPLE button.
 - The pump should continue to run and the display should update every survey cycle.
- The instrument remains in the survey mode until one of the following occurs:
 - The sensor is saturated.
 - A LO BAT (low battery) signal is encountered.
 - An HL (high hydrogen sulfide level) is encountered.
 - The instrument is turned OFF.
- Press the power OFF button to end the survey mode.

RANGE	CONCENTRATION	RESPONSE TIME
0	0.001 to 0 .099 ppm	20 Seconds
1	0.10 to 0.99 ppm	15 Seconds
2	1.0 to 9.9 ppm	6 Seconds
3	10 to 50 ppm	3 Seconds

NOTE: Approximately 100 samples at 0.5 ppm may be taken before the sensor saturates and regeneration is required.

Operating on AC Power or Generator

- For stationary use, the 631-X may be operated on AC power.
 - Operating the instrument on AC power at all times eliminates the need for the battery pack and its necessary maintenance.
 - The battery may be unplugged or removed completely whenever the instrument is operating on AC power.
- When a generator is used to power the Jerome 631-X, a high quality line conditioner or voltage regulator is required to ensure a pure sine wave and regulated voltage is applied to the instrument. The gold film sensor may be damaged by voltage that varies in amplitude or by surges, spikes, and/or noise on the power line.

Operating on Internal Battery Power

- For portable use, the 631-X may be operated on Battery power.
 - When you operate the instrument on battery power, please be aware of the following:
 - ◆ A fully charged battery pack, AZI P/N Z4000-0907, provides power for a minimum of six (6) hours of operation.
 - ◆ For operating more than six (6) hours, an extra fully charged battery pack is needed.
 - ◆ Complete battery recharging takes 14 hours. Refer to Charging Batteries on page 17.
 - ◆ The 631-X uses a rechargeable Nickel Cadmium (NiCad) battery. Dispose of worn-out batteries properly when you are replacing the battery pack.

External battery power

A special version of the Jerome 631-X and a DC Power Kit are available to operate the instrument from a secondary DC source. The source may be a car/truck battery or a storage cell used in conjunction with solar panels.

Call AZI Customer Service at 800-528-7411, 602-470-1414, or e-mail support@azic.com for additional information.

Charging Batteries

- Press the power OFF button.
- Connect the AC power cord between the 631-X power receptacle and an AC power source.
 - Complete battery recharging takes 14 hours.
 - The 631-X contains a trickle charger so it may be continually plugged into an AC power source without damaging the battery pack.
- The battery pack may be charged outside the instrument with an optional AZI IDC Battery Charger. (AZI P/N 4000-1011, for 115 VAC, P/N 4000-1012, for 230 VAC)

Obtaining Maximum Battery Life

There are certain inherent limitations to NiCad batteries. The primary limitation is a memory effect that occurs when the batteries are partially discharged and then recharged, repeatedly. This memory leads to a drastic reduction in the usable battery life. To prevent this memory effect, periodically allow the battery pack to discharge completely, and then recharge the battery pack.

- To obtain maximum battery life, follow these three (3) steps:
 - At least once a month wait until LO BAT appears on the digital meter before recharging the battery pack.
 - Charge the battery pack when the LO BAT indicator comes on. Excessive discharge can damage the battery pack.
 - Before storing the instrument verify the power is OFF.
- When the batteries fail to hold a charge, the battery pack should be replaced.
 - Battery life under normal usage is approximately 1 year, depending on the number of charge and discharge cycles.

5. MAINTENANCE

Preventive Maintenance Calendar

To keep the Jerome 631-X operating at peak performance, follow the maintenance schedule below as a guide. Since maintenance is more a function of application and amount of use rather than time, your requirements may be different from the listed schedule. Call AZI Customer Service at 800-528-7411, 602-470-1414, or e-mail support@azic.com for additional guidance for your environment and operation.

PART/COMPONENT	MAINTENANCE CYCLE	REFER TO PAGE
Charge batteries	At least once per month, after 1 month's storage, or when LO BAT appears	Page 17
Change .25 inch fritware	Weekly or as needed	Page 19
Change internal filters and tubing	After 6 months of use or as needed	Page 20
Replace zero air filter ¹	Annually	
Factory calibration	Annually	Page 23
Calibration check	Monthly or as needed	Appendix A, Page 36
Replace batteries	Annually or as needed. The battery pack contains NiCad batteries. Dispose of properly.	Page 21

NOTE: Install the zero air filter into the instrument's intake during storage.

¹ Zero air filters, LFS and LFD scrubber filters contain Resisorb™. Call AZI Customer Service at 800-528-7411, 601-470-1414, or e-mail support@azic.com for a copy of the Material Safety Data Sheet. Dispose of all filters properly.

Flow System

The Jerome 631-X's flow system is the crucial link between the sensor and the sample. For the instrument to perform correctly, the flow system must be properly maintained. The user maintainable components of this system are the intake filter (.25 inch fritware), two scrubber filters and connecting tubing.

Check the Preventive Maintenance Calendar on page 18, for a suggested schedule for changing fritware and scrubber filters. The Tygon™ tubing in the system must be free of crimps for proper flow.

Part	Part Number
Scrubber Filter	Z2600 3930
LFS Scrubber Filter	Z2600 3933
LFD Scrubber Filter	Z2600 3934
.25 inch Fritware Filter	2600 3039
Tygon™ Tubing - 1/8" I.D. (1')	2500 3001
Tygon™ Tubing - 1/16" I.D. (1')	2500 3002

.25 inch Fritware Filter

Replace the .25 inch fritware filter once each week or as needed. In dusty environments, the fritware filter may need to be replaced as often as once a day. Replacement .25-inch fritware filters are available from AZI, Consumable Sales at 800-528-7411 or 602-470-1414.

- Unscrew and remove the intake.
- Push the old fritware filter disc out of the intake with your trimmer tool.
- Avoid touching the new fritware disc with fingers. Use tweezers to insert the new fritware.
- Use the blunt end of the trimmer tool to seat the fritware disc firmly against the inner ledge of the intake.
- Screw the intake back on the Jerome 631-X.



CAUTION:

The stem coming from the instrument onto which the outer intake housing is attached must be securely held in place. If loose, the tubing inside the instrument can become twisted when the intake housing is replaced. It may be necessary to open the instrument and tighten the hold-down nuts inside the instrument. Call AZI Customer Service at 800-528-7411, 601-470-1414, or e-mail support@azic.com if you have any questions



Internal Filters

- Replace the internal filters after six (6) months of use, or as needed.
- Press the power OFF button and unplug the power cord.
- Remove the two (2) side screws from the intake end of the instrument and open the case.
- Carefully disconnect the Tygon tubing from both ends of the filters and discard the old filters.

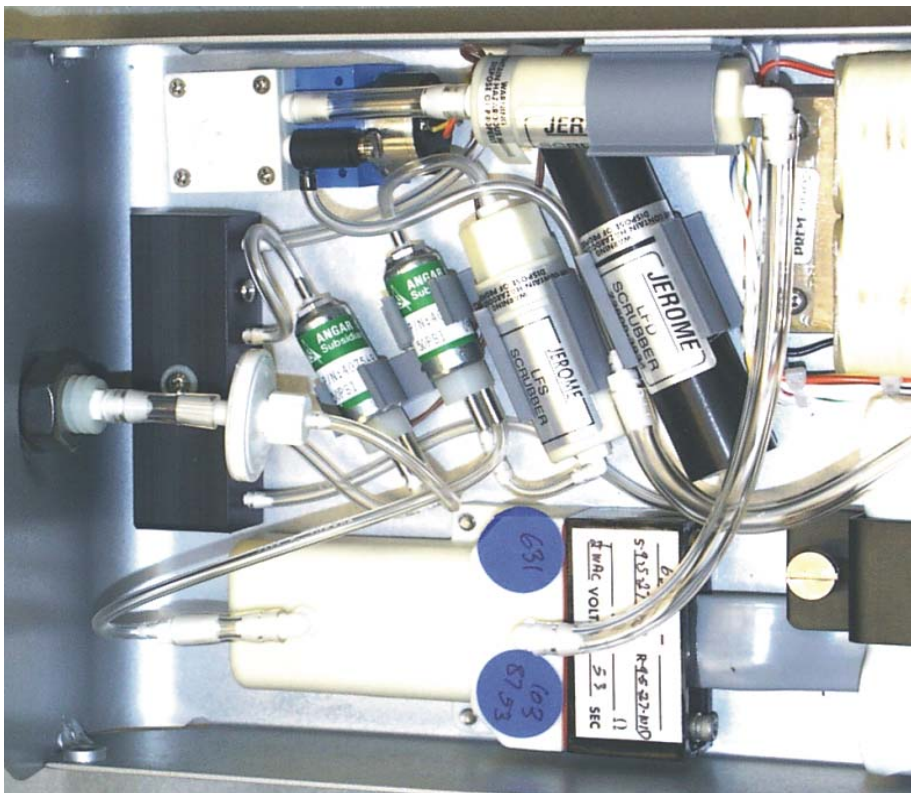

CAUTION:

Scrubber filters contain Resisorb. Used filters, especially the scrubber filter may contain hydrogen sulfide also. Use proper methods when disposing of used filters. Call AZI Customer Service at 800-528-7411, 601-470-1414, or e-mail support@azic.com for a copy of the Resisorb MSDS or for other questions.

- Connect the new filters to the Tygon tubing, ensuring all straight hose barbs point toward the intake/pump corner of the case and elbow hose barbs point toward the sensor housing as shown in the illustration.
 - Push the Tygon as far as it will go onto the filter fittings.
- Push the filters into the mounting clips.
- Remove any crimps or twists in the tubing and ensure that tubing connections are secure. If the tubing is loose, readings may not be accurate. Replace any tubing that has deteriorated due to heat and/or age.
- Close the case and replace the screws.
- Dispose of all filters in accordance with state and federal environmental regulations.

Replacing the Battery Pack

- Press the power OFF button.
- Unplug the power cord.
- Remove the two (2) side screws from the intake end of the instrument and open the case lid.
- Disconnect the battery connector from the board.
- Loosen the two (2) captive screws holding the battery bracket and remove the bracket.
- Remove the old battery pack and replace with a new battery pack.
- Replace the battery bracket and tighten the captive screws.
- Connect the new battery connector to the board.
- Close the case and replace the two (2) side screws.
- Dispose of the old NiCad battery in accordance with state and federal regulations.

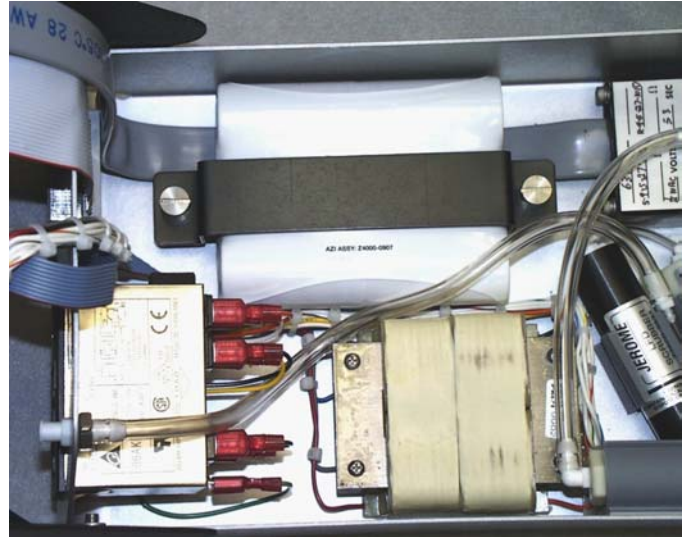

Setting the Input Voltage

Instruments are factory set and calibrated to use the power setting requested on the order. However, the voltage setting is easily changed to use either 110 or 220 VAC.

- Ensure the instrument is turned OFF and unplugged.
- Locate the voltage selector on the rear of the instrument.
- Insert a small screwdriver in the voltage selector slot and turn the selector until the arrow points toward your setting choice and a click is heard.

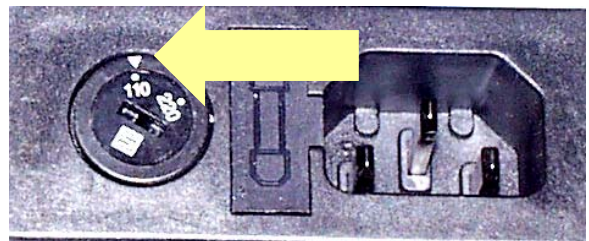

Changing the Fuse

If the instrument display reads .P.P.P when the instrument is connected to AC power or when REGEN is pressed, or if the battery will not charge, the fuse may need to be replaced. The AC line power could also be less than 100 VAC (220 VAC). Check the fuse with an ohmmeter and the AC line power with a voltage meter.

- Locate the power receptacle on the rear of the instrument.
- Insert a small screwdriver in the slot, located in the power receptacle, and gently slide the fuse compartment out.
- If the fuse in the open-sided clip is open, remove and discard it.
- Replace the discarded fuse with the spare fuse located in the slide-out spare fuse compartment.
- Replace the fuse compartment in the power receptacle.
 - As soon as possible, replace the spare fuse with another 1A, 250V, time delay fuse, AZI P/N 5100 1012).

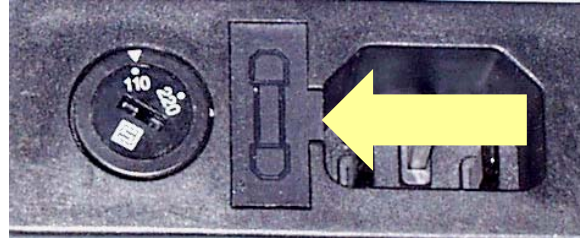

6. CALIBRATION

The Jerome 631-X's gold film sensor is inherently stable and does not require frequent calibration. The interval between calibrations depends upon the application and frequency of use; however, the recommended interval is every 12 months.

The Jerome 631-X has been factory calibrated using laboratory equipment containing NIST traceable permeation tubes. These permeation tubes have a rated accuracy of +/- 2%. In order to calibrate the Jerome 631-X, a sophisticated calibration system is required that ensures stability of the calibration gas source, eliminates any pressure in the calibration gas stream, and controls the temperature of the calibration environment. Calibration requires the controlled environment, gas source, and computer software, available only at the factory or authorized repair/calibration facility.

We strongly recommend you take advantage of our calibration and maintenance service at Arizona Instrument. Call Customer Service at (800) 528-7411 or (602) 470-1414 to arrange re-calibration. A certificate of calibration is issued from AZI when your instrument is factory calibrated.

Verification of Calibration and Quality Control

The Functional Test Module, AZI P/N Z2600 0918, is used to determine if your instrument is within calibration tolerances between recommended annual factory calibrations. It allows you to have complete confidence in the sample results. This test verifies proper instrument operation through the introduction of a known concentration of hydrogen sulfide into the Jerome analyzer. **THIS TEST DOES NOT CALIBRATE THE INSTRUMENT.**

If your application requires frequent verification of instrument function, this test demonstrates the unit's operation, calibration, and function. Recording FTM results in an instrument log provides a quality control/quality assurance record of instrument function between regular calibrations. If test results fall within the expected range, you may assume the instrument is functioning correctly.

See APPENDIX A - 631-X FUNCTIONAL TEST MODULE on page 36 for more information about the FTM procedures. Complete instructions for use are supplied with the test kit, AZI P/N Z2600 0918.

To order the FTM, contact your AZI Sales Representative at (800) 528-7411 or (602) 470-1414.

7. 631-X TROUBLESHOOTING

Symptom	Possible Cause	Solution
Power Problems		
Unit does not turn ON. Unit turns on when power cord is plugged in. LCD displays 000 when instrument is operating on AC power.	Discharged battery or Dead battery.	Recharge battery for a minimum of 14 hours. Refer to page 17. Replace battery. Refer to page 21.
Unit does not turn on when connected to AC power cord.	Open fuse. Insufficient power. Internal component failure.	Replace fuse. Refer to page 22. Use a voltmeter to verify there is power to the AC outlet. Call AZI Customer Service for information at 800-528-7411 or 602-470-1414.
Regeneration & Zero Problems		
LCD displays .8.8.8.	Sensor saturated.	Do not attempt to adjust zero pot. The sensor must be regenerated. Refer to page 12 for information.
LCD displays .L.L.L when taking first sample.	Changes in temperature.	Readjust zero pot. See page 13 for information.
LCD displays H at finish of sensor regeneration when zero is pressed.	Internal contamination may redeposit hydrogen sulfide from flow system onto gold film sensor.	Remove and replace fritware filter, intake filter disk, scrubber filters and Tygon tubing. Refer to "Flow System" on Page 19. Check tubing for kinks or crimps. Repeat regeneration cycle. Refer to page 12.
Zero adjust pot cannot be adjusted to 0.	Pot not turned sufficiently. Sensor may be ruptured or pot may be broken.	1. Turn zero adjust up to 20 times to reach the end. Pot will "click" softly. 2. If no "0", turn pot slowly in opposite direction until display reads "0". 3. If still unchanged, call AZI Customer Service at (800) 528-7411 or 602-470-1414.

Sampling Problems		
Airflow is restricted during the sensor regeneration cycle, causing possible permanent damage.	Kinks and crimps in the Tygon tubing.	Periodically check the Tygon tubing inside the instrument. Refer to page 20.
High erratic results.	Internal hydrogen sulfide contamination.	<ol style="list-style-type: none"> 1. Install zero air filter in intake and tighten intake nut. Press SAMPLE button. After three samples, if readings are over 0.003 ppm, replace fritware filter, intake filter disk, and Tygon tubing. Refer to page 19. 2. Perform sensor regeneration with the zero air filter in intake. Refer to page 12. Retest if necessary. Replace scrubber filters and Tygon™ tubing. Refer to page 20.
High/erratic results	Intake and internal filters may become clogged and need replacement when sampling in a dusty or humid area.	<ol style="list-style-type: none"> 1. Open instrument and check for pinched, crimped or disconnected internal tubing. 2. In extreme conditions, an additional particle filter may be installed on the intake.
High/erratic results Readings vary more than 0.003 ppm when in survey mode.	Loose connections to gold film sensor.	Place a zero air filter into the intake. Place the instrument in survey mode. Move the unit as samples are being taken. Call AZI Customer Service at 800-528-7411 or 602-470-1414 for assistance.
Low response or erratic readings after a long period of non-use.	May need a second regeneration cycle.	<ol style="list-style-type: none"> 1. Wait 30 minutes and perform another sensor regeneration. 2. Test with FTM. Refer to page 36. 3. If still unresponsive,
False readings, may go to .8.8.8 or .L.L.L.	Extremely cold or extremely warm air sampled into unit.	If sampling under these conditions, install zero air filter in intake. Sample until display reads 0.003 ppm or less. This equilibrates sensor temperature with the temperature of the sample air stream. Remove filter and take samples.

Miscellaneous Problems

Display reads .P.P.P when regeneration is attempted.	Power cord not attached. Blown fuse. Line voltage less than 100 VAC (or less than 200 VAC for 220 unit). Cycles dipswitch set incorrectly.	Check power cord for connection Replace fuse. Refer to page 22. Check line voltage settings. Refer to page 21. Check input cycle settings. Refer to page 39. If fuse and line voltage are OK, it may be circuit board adjustment or component failure. Call AZI Customer Service at 800-528-7411 or 602 470-1414.
Display reads .E.E.E	Very low battery.	Recharge battery. Refer to page 17. Replace battery. Refer to page 21.

8. JEROME 631-X TECHNICAL SPECIFICATIONS

Range	0.003ppm (3ppb) to 50ppm H ₂ S in four graduated ranges
Sensitivity	0.003ppm H ₂ S
Precision	5% relative standard deviation
Accuracy	Range 0: ± 0.003ppm at 0.050ppm H ₂ S Range 1: ± 0.03ppm at 0.50ppm H ₂ S Range 2: ± 0.3ppm at 5.0ppm H ₂ S Range 3: ± 2ppm at 25ppm H ₂ S
Response time-sample mode	
10 to 50 ppm	13 seconds
1.0 to 10.0 ppm	16 seconds
0.10 to 1.00 ppm	25 seconds
0.001 to 0.100 ppm	30 seconds
Response time-survey mode	
0 to 50 ppm	3 seconds
1.0 to 9.9 ppm	6 seconds
0.10 to 0.99 ppm	15 seconds
0.001 to 0.099 ppm	20 seconds
Flow rate	150cc/min (0.15 liters/min)
Power requirements	100-120 V~, 50/60 Hz, 1 A or 220-240 V~, 50/60 Hz, 1 A
Fuse	F1A T250V, 5mm X 20mm
Internal battery pack	Rechargeable Nickel Cadmium
Operating environment	0° to 40°C, non-condensing, non-explosive
Case construction	Aluminum alloy
Dimensions	15 cm x 33 cm x 10 cm (6" w x 13" l x 4" h)
Weight	3.18 kilos (7 pounds)
Digital meter display	Liquid crystal display (LCD)
Certification	CE mark on 220-240 V~, 631-XE model only.

Optional Communications Capability

Alarm output	30V DC, 100mA
Data output	1. RS-232 Serial, Baud Rate 1200 for use with data logger, and/or Jerome communication program. 2. RS-232 Serial data format with 0 & 20mA current logic levels; Baud Rate 1200 (special industrial applications) and Analog 20 mA output.

"OPTION BOARD" - See APPENDIX D - JEROME 631-X OPTION BOARD on page 40.

Analog output	0 to 2V or 4 to 20 mA
Auto sample interval	5, 15, 30, or 60 minutes
Auto regeneration interval	6, 24 or 72 hours

Instrument I/O Interface

The 631-X I/O port (25 pin D-sub) provides the following functions:

- Serial data communication
 - Interface type: RS-232C full duplex, DCE
 - Parameters: 1200 Baud, 1 start bit, 8 data bits, 2 stop bits, no parity
 - Pin assignments:
 - Pin 1 Protective ground
 - Pin 2 Data in
 - Pin 3 Data out
 - Pin 7 Data ground
- Serial current loop
 - Interface type: 20mA current loop, full duplex
 - Parameters - 1200 Baud, 1 start bit, 8 data bits, 2 stop bits, no parity
 - Pin assignments:
 - Pin 1 Protective ground
 - Pin 4 Data out (+)
 - Pin 5 Data in (+)
 - Pin 14 Data out (-)
 - Pin 16 Data in (-)

- Alarm output
 - Maximum voltage 30 VDC
 - Maximum current 100mAmp
 - Pin assignments:
 - Pin 9 Switched battery (+)
 - Pin 10 Alarm output (open collector, active low)
 - Pin 7 Battery ground (-)
 - Pin 23 Battery ground (-)



- Switched battery connection for data logger
 - Pin assignments:
 - Pin 9 Battery (+)
 - Pin 7 Battery ground (-)
 - Pin 23 Battery ground (-)

- Unswitched battery connection for external battery pack pin assignments
 - Pin assignments:
 - Pin 15 Battery (+)
 - Pin 19 Battery (+)
 - Pin 7 Battery ground (-)
 - Pin 23 Battery ground (-)

NOTE: Pins 6, 8, 11, 17, 18, 20 and 21 are non-standard and should not be connected.









9. ACCESSORIES & MAINTENANCE PARTS

PART #	ITEM DESCRIPTION	
Y631 0901	631 Accessory Kit (See pictures beginning on page 32)	
	1400 2002	Probe
	1400 3010	Tubing Adapter, 1/4" to 1/8"
	2300 0001	Trimmer Tool
	2600 3039	.25 Fritware
	6000 4003	Line Cord, 115 VAC - USA and Canada
	Alt. 200-0003	Line Cord, 220-240 VAC - England
	Alt. 200-0008	Line Cord, 220-240 VAC - Europe
	Z2600 3905	Zero Air Filter
Z2600 0918 Y2600 0920	631 Functional Test Module and Accessory Kit (See pictures beginning on page 32)	
	1300 0031	1/8" x 3/16" reducer
	1400 3010	Tubing adaptor
	2300 0003	Allen wrench
	2500 3001	1' of 1/8" Tygon tubing
	2500 3010	1' of 3/16 Tygon tubing
	2600 3010	Filter cap
	2600 3055	1 Lb. Desiccant
	2800 2044	(2) Guide pins
	6000 4003	115 VAC Line Cord
	Z2600 3944	Permeation Tube Assembly
	SS-112	FTM Operation Manual
Y631 0905	631 Maintenance Kit (See pictures beginning on page 32)	
	2500 3001	1' of 1/8" Tygon tubing
	2500 3002	2' of 1/16" Tygon tubing
	2600 3039	.25 inch fritware
	Z2600 3905	Zero Air Filter
	Z2600 3930	Scrubber Filter
	Z2600 3933	LFS Scrubber Filter
	Z2600 3930	LFD Scrubber Filter
	Z4000 0907	Battery Pack Assembly

<p>Y6100 0057</p>	<p>Jerome Data Logger Includes the Jerome Data Logger and JCI Software Kit.</p>	 <p>A black rectangular device with a white label. The label includes the text: 'FOR SERVICE CALL 1-800-235-1350 ARIZONA INSTRUMENT', 'HIGH MEMORY LEVEL FULL', 'JEROME DATA LOGGER DATA ACQUISITION SYSTEM', and the AZI logo.</p>
<p>Y6100 0054</p>	<p>Jerome Communication Software Kit</p>	 <p>A collection of items including a spiral-bound manual titled 'Jerome Communications Interface Software User's Manual', a black floppy disk with a white label, a coiled grey cable, and various connectors and components in plastic bags.</p>
<p>Y411 0904</p>	<p>Hard Side Carry Case Includes a molded case with die cut foam rubber inserts to hold the Jerome 631-X and accessories.</p>	 <p>An open, black hard-shell carry case with a blue, textured foam interior lining. The case is shown from a top-down perspective, revealing the die-cut foam inserts designed to hold the logger and its accessories.</p>

1400 0052	Soft Field Carrying Case Hand/shoulder case with pockets for accessories.	
-----------	---	--

Spare Parts

1400 2002	Probe	
2300 0001	Trimmer	
1300 0031	1/8 x 3/16 reducer	
Z4000 0907	Battery Pack Assembly	
Z2600 3933	LFS scrubber filter	
Z2600 3934	LFD scrubber filter	
Z2600 3930	Scrubber filter	
Z2600 3905	Zero air filter	
1400 3010	Tubing adapter	

Y26003945 Intake Kit



PS 151 Tube Nut



2600 3039 .25 inch fritware



2500 3001 Tygon tubing 1/8" I.D. (1 foot)



2500 3002 Tygon tubing 1/16" I.D. (1 foot)



4000 1011 115 VAC IDC battery charger
Used to charge an uninstalled
battery



4000 1012 230 VAC IDC battery charger
Used to charge an uninstalled
battery



6000 4003 100-120 VAC Line Cord



Alternate – 220-240 VAC Line Cord for
200-0003 England



Alternate – 220-240 VAC Line Cord for
200-0008 Europe



5100 1012 Spare Fuse



6000 1055 JeromeCommunication Interface Cable



6000 1045 Adaptor, RS-232, 9M/25F



For current prices and delivery information, call AZI Customer Service at (800) 528-7411 or (602) 470-1414.

10. Factory Calibration Service

Service includes filter replacement, component testing, and instrument calibration to NIST traceable standards.

For scheduling and shipping authorization, call AZI Customer Service at (800) 528-7411 or (602) 470-1414.

11. APPENDIX A - 631-X FUNCTIONAL TEST MODULE

The Jerome Hydrogen Sulfide Functional Test Module provides a fast and easy method of verifying that Jerome 631-X Hydrogen Sulfide Analyzers are within specifications.

The Functional Test Module is beneficial:

- In applications where frequent verification of functionality is required, such as ISO 9000 documentation,
- To verify proper instrument operation when unexpected readings are obtained in normal sampling,
- As part of a weekly maintenance routine, and
- To determine if analyzer calibration is needed.

Simple Operation

The Functional Test Module includes a permeation tube containing hydrogen sulfide. When activated, the test module releases this H₂S from the permeation tube at a specific, known concentration. The H₂S flows over the gold film sensor of the Jerome analyzer, which then measures the amount of exposure to the gas. The flow rate and temperature of this release are factory set to provide a concentration of approximately 250 ppb (0.250 ppm) ± 20%. The user then compares the reading on the Jerome analyzer with the known concentration from the module. If the H₂S level shown on the analyzer's display falls within the expected range (approximately 250 ppb), the instrument is functioning properly. If the level is not in the expected range, it should be returned to the factory for NIST-traceable calibration.

See page 30 for a list of the components that make up the FTM and its accessory kit.

The FTM, with the exception of the permeation tube, carries a limited one-year warranty to be free from defects or workmanship. The permeation tube is warranted for 90 days. Refer to the FTM Operation Manual P/N SS-112 for complete operation and warranty information.

12. APPENDIX B - JEROME COMMUNICATIONS SOFTWARE

The Jerome Communications Software (JCS) is used with 631-X Hydrogen Sulfide Analyzers that feature the communications configuration option.

- The JCS allows the user to program the instrument for unattended monitoring and to download recorded data stored in the Jerome data logger.
- Automatic sampling can be initiated every one (1) to sixty (60) minutes with programmable audible alarm levels.

Instrument Control with Real-Time Graphics

When connected to a Jerome 631-X analyzer, the software collects and graphs data as it is being received and performs statistical analysis. To provide maximum resolution, the graph is “auto-scaling” in both time (hours, days or weeks) and concentration. Alarm levels can be set by the user. Alarms trigger an audible buzzer at the computer and activate a relay on the instrument for remote indicators, such as an external light or fan.

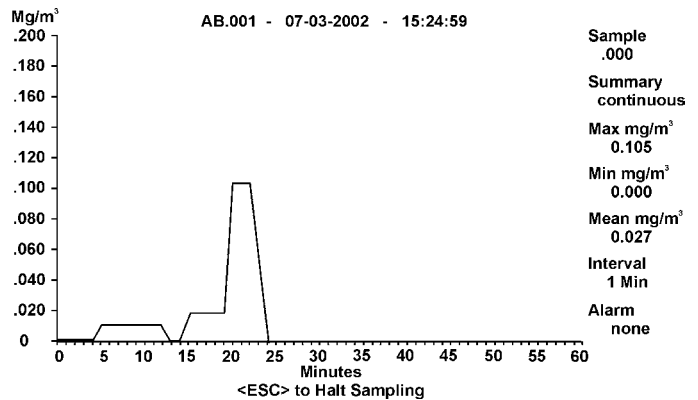

The JCI software is menu-driven and easy to use. Each display screen is designed for clarity with self-explanatory menu options. Select menu options using the arrow keys and the “Enter” key.

The user creates records, or files, for computer storage of collected data. Data is easily retrieved for later viewing, graphing, printing, or editing with spreadsheet or word processing software (not provided). Data can be used for ongoing record keeping or for fulfilling local regulatory requirements.

Jerome Communications Interface Program

[Main]

Operate Instrument

Display Stored Data

Program/Read Data Logger

Configure

Exit Program

↑↓=Move | ←=Select | <ESC>=Exit Menu

JCI Kit Contents

- One disk containing the Jerome Communication Software
- Jerome Communication Interface Cable, AZI P/N 6000 1055
- Cable Adaptor, SR-232, 9M/25F, AZI P/N 6000 1045
- User's manual

System Requirements

- Instrument: Jerome 631-X with the communications option. These Jerome instruments have a DB-25 connector and related internal hardware and firmware.
- Computer: IBM (or compatible) PC, XT, AT, 286, 386, 486 or Pentium
- Operating System: MSDOS or PCDOS 2.1 or higher
- Video: CGA, EGA or Hercules-compatible monochrome (VGA operates as EGA). Install MSHERC.COM (provided) before using Hercules monochrome.
- Memory: 512 K bytes or larger
- Interface: Serial interface card
- Printer: IBM, Epson or HP LaserJet Series II graphics compatible

The software can run from the program disk or from the computer's hard drive. Before using the software, familiarization with the Jerome Hydrogen Sulfide Analyzer and user's manual is recommended.

Data Logger Option

The software can also program the Jerome Data Logger (AZI P/N 6100 0010) used with the Jerome analyzer. The computer programs the data logger that then attaches to the DB-25 connector on the rear of the instrument. The data logger initiates automatic sampling, triggers alarms and stores data. This optional accessory enables portable automatic sampling without a dedicated computer.

13. APPENDIX C - INTERNAL DIP SWITCH SETTINGS

The DIP switch identified as SW2 on the 631-X control board is located at the top center of the board.



CAUTION:
 Switch the instrument's power to OFF before opening the instrument and changing DIP switch settings.

DIP Switch Settings:

Switch #	Position	Function	Comment
1	ON	AUTORANGE	DISABLED (SEE DIP SWITCHES 5 & 6)
1	OFF	AUTORANGE	ENABLED
2	X	NOT USED	
3	X	NOT USED	
4	ON	ZERO DISPLAY: 00-99	
4	OFF	ZERO DISPLAY: L-O-H	

Switch #	Function	Comment
5	6	RANGE
ON	ON	0 (.000 - .099PPM) 30 SECONDS
ON	OFF	1 (0.10 - 0.99 PPM) 25 SECONDS
OFF	ON	2 (01.0 - 09.9 PPM) 16 SECONDS
OFF	OFF	3 (10 - 50 PPM) 13 SECONDS

14. APPENDIX D - JEROME 631-X OPTION BOARD

Proper use of this board requires that the base instrument be fully functional and set correctly for the intended operation.

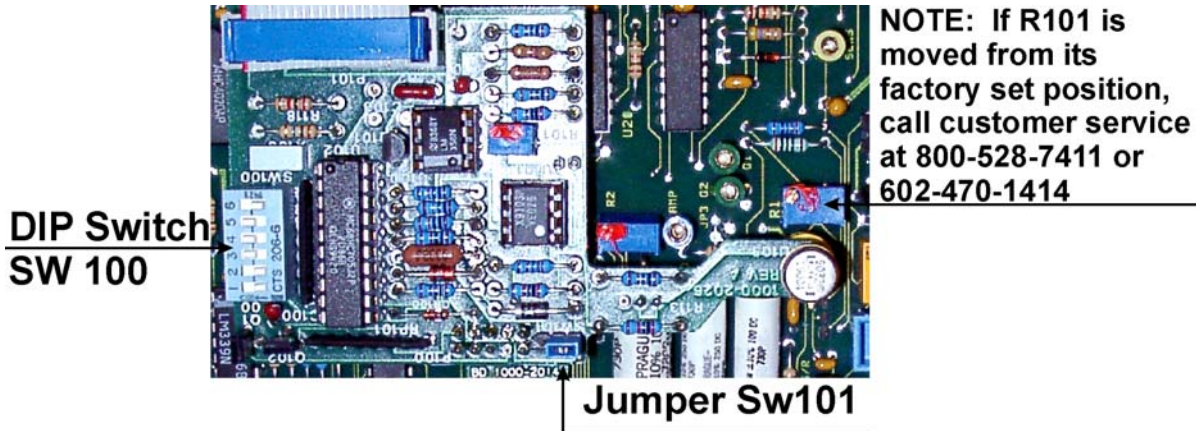

Auto-Zero

With the option board installed, the 631-X has a limited auto-zero function. This function cannot be disabled and is transparent to the user. The instrument can be manually zeroed as described in “Zero Adjust” on page 13. However, if the instrument is to be operated by personnel not familiar with the procedure or if it is operated unattended, the auto-zero function should satisfactorily zero the unit after each sensor regeneration.

Instrument Zeroing

The Jerome 631-X has essentially three ways to zero the sensor reading before samples are taken if the option board is installed.

- The instrument automatically re-zeroes between samples so that each sample is a unique reading. To take a sample, simply press the SAMPLE button.
- The manually adjusted zero, using the switch on the top of the 631-X is used to re-establish a baseline between the reference and sensor gold films **only after a sensor regeneration**. This zero is manually adjusted by pressing the ZERO button and turning the potentiometer on the top of the instrument until the display reads 0. **Adjust only after sensor regeneration**; it is normal for H to be displayed after sampling.
- The 631-X option board provides an auto-zero feature following regeneration that is invisible to the user.

- In some cases, the instrument cannot resume sampling after regeneration. .L.L.L appears on the display when the ZERO button is pressed and the error message “manual bridge adjust needed” is added to the notes column of the JCS text file when the JCS is used. If this problem persists, it may be necessary to re-set the auto-zero.
- When necessary to re-adjust the auto-zero point:
 - Turn the instrument off.
 - Make a note of the original DIP switch settings of SW100 on the option board.
 - On red DIP switch on the control board, SW2, turn DIP switch 4 to ON.
 - Set the switches on the option board’s blue DIP box, SW100, to 1,2,6 OFF; 3,4,5 ON.
 - Turn the instrument ON.
 - Press the Zero button and adjust the potentiometer on top of the instrument until the numbers read between 5 and 7.
 - Switch option board DIP #1 OFF and ON three times, leaving it ON.
 - While pressing the ZERO button, turn the potentiometer on the option board until the numbers read between 5 and 7. Note the display will flicker one digit.
 - Return all switches to their original position.

NOTE: The higher the auto-zero number, the lower the sensor capacity and the more sensor regenerations are needed.

Timed Regeneration

If the unit is to be operated unattended for extended periods, AZI recommends that the sensor be regenerated regularly. While operation under JCI or data logger control automatically regenerates saturated sensors. Regeneration will not occur as shown when sample streams have a very low concentration of H₂S. The option board controls regeneration on a regular basis, every 6, 12 or 24 hours.

The regeneration intervals are set through a combination of switch settings as shown in the following table:

----- SW100----- Switch #1 Switch #2		REGENERATION Interval (Hrs.)
OFF	OFF	OFF
ON	OFF	6
OFF	ON	12
ON	ON	24

Auto-Sample

If a data logger is connected and operating in the manual sampling mode or a data logger is not connected the following automatic sampling rates may be selected with SW100 dip switch settings:

Dip switch settings			Sampling frequency
3	4	5	
ON	ON	ON	No automatic sampling
OFF	ON	ON	5 minutes
OFF	OFF	ON	15 minutes
OFF	ON	OFF	30 minutes
OFF	OFF	OFF	1 hour

This auto-sample function will not function if a data logger is connected and operating in automatic sampler mode programmed through the JCS.

4-20 MA Analog Output

The analog output signal at pin 18 of the 25 pin connector can be configured to provide the instrument's native mode 0-2 Volt output or the optional 4-20 mA output by setting the option board jumper (SW101) to the "V" position for voltage, or the "I" position for current. (Pin 23 is the ground pin for the analog output function. Pin 18 is positive with respect to the ground pin).

- The 0-2 Volt output circuit can drive loads of 10 k ohms or higher.
- The 4-20 mA output is a passive transmitter and requires the connected receiver to supply between 10 and 28 volts of excitation potential.

The 631-X must have the auto ranging feature disabled in order to get accurate analog output readings. The approximate range of the H₂S concentration must be known before the instrument can be set into that specific range (0,1, 2 or 3). The analog output signal is based on each individual range and not the entire range (0-50 ppm).

Note that neither analog output circuit is floating. The negative terminals of both circuits are connected to the instrument's common ground buss.

SW101 Functions:

V =	0-2V analog output
I =	4-20 ma analog output

Jerome 631-X instruments shipped after early 1995, are capable of providing 0-2 volts analog output. Instruments shipped before that time can be upgraded by a firmware update and adjustment.

Instruments that are capable of 0-2 volt output can be upgraded to the 4-20 mA output with the addition of an option board upgrade. This must be installed at the factory.

Connection and Setup:

- 0-2 volt devices connect as shown in Figure 1. If the instrument includes an option board, be sure its analog jumper (SW101) is set to the “V” position.

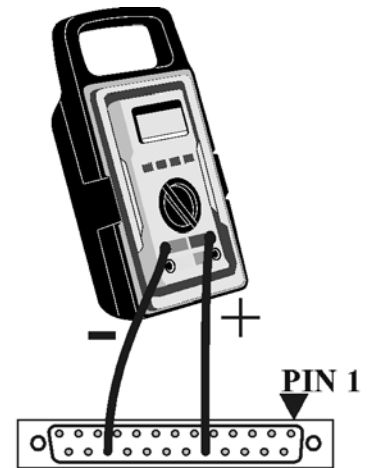

**REAR OF CONNECTOR,
CONNECT PINS 18 AND 23 FOR
0-2 VOLT OUTPUT.
JUMPER ON BOARD IS AT “V”
Figure 1**

- The 4-20 mA active receivers connect as shown in Figure 2. The active receiver must contain a voltage source to power the loop current. The receiver must also have an isolated input circuit. That is, it must not be connected to ground or to a voltage source referenced to ground. Be sure that jumper SW101 is set to the “I” position before power is applied.

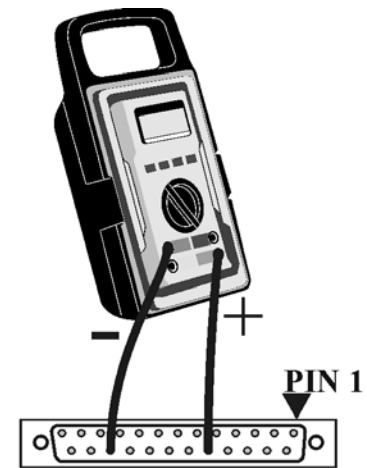

**REAR OF CONNECTOR,
CONNECT PINS 18 AND 23 FOR
4-20 mA OUTPUT.
JUMPER ON BOARD IS AT “I”
Figure 2**

- The 4-20 mA passive receivers must not contain a voltage source to power the loop current. They do require the addition of a separate isolated power supply. Typically a supply that delivers 15 to 20 volts DC at 50 mA is sufficient. Wire these as in Figure 3. Note that some 12-volt DC wall transformers (as used on portable equipment) may deliver 15 to 20 volts when they are lightly loaded. The CUI/Stack #AD-1220M is a commonly available example of a 12 volt 200mA supply that will deliver around 18 volts nominal when loaded below 20 mA.
- Be sure that both the power supply used and the passive receiver are floating (not connected to earth ground). If either is not floating, the circuit will not work and damage may occur.
- Ensure that jumper SW101 is set to the “I” position before power-up.

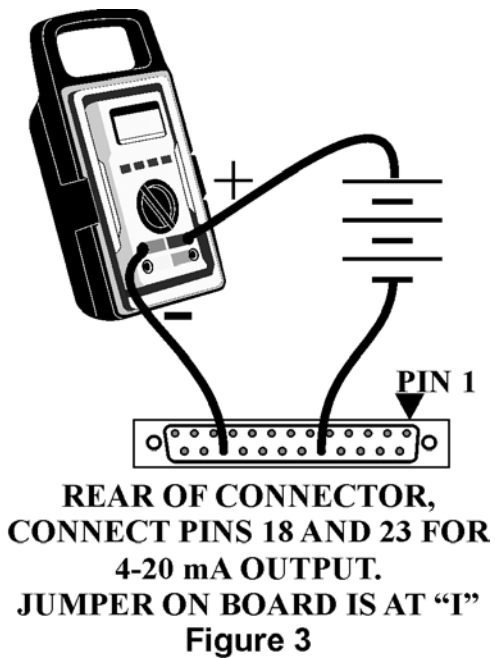

Fresh Air Solenoid

An external three-way solenoid can be used to provide fresh air or conditioned air during sensor regeneration. This may be necessary if the sample stream lacks molecular oxygen. A low current six volt DC solenoid, connected between pins 19 and 11 of the 25 pin rear panel connector, will be energized during the regeneration cycle if the option board SW100 switch 6 is placed in the OFF position.

If needed, the circuit may be built from the following components and configured as shown in the following diagram. It will only function if the option board is installed in the 631-X instrument.

Required Parts:	Suggested Part	Similar AZI P/N
1 solenoid, 6volt 3way	Angar P/N 407569	1300 1004
1/8" to 1/16" tubing adaptor	Any	1300 0025
1/2" clamp, adhesive mount	Any	6000 0013
1/8" tube to instrument adaptor	Any	1400 3010
3" 1/8" tubing	Tygon Formula R3603	2500 3001
A/R 1/16" tubing	Tygon Formula R3603	2500 3002
1 25 pin male DB-25 connector Solder-cup style	AMP 747912-2	None *
1 connector hood	AMP 749626-2	None *

* These are types not stocked by AZI, but should be available overnight from many AMP stocking distributors such as Digi-Key Corporation. There are multiple suitable alternatives such as Radio Shack's 276-1547 and 276-1549.

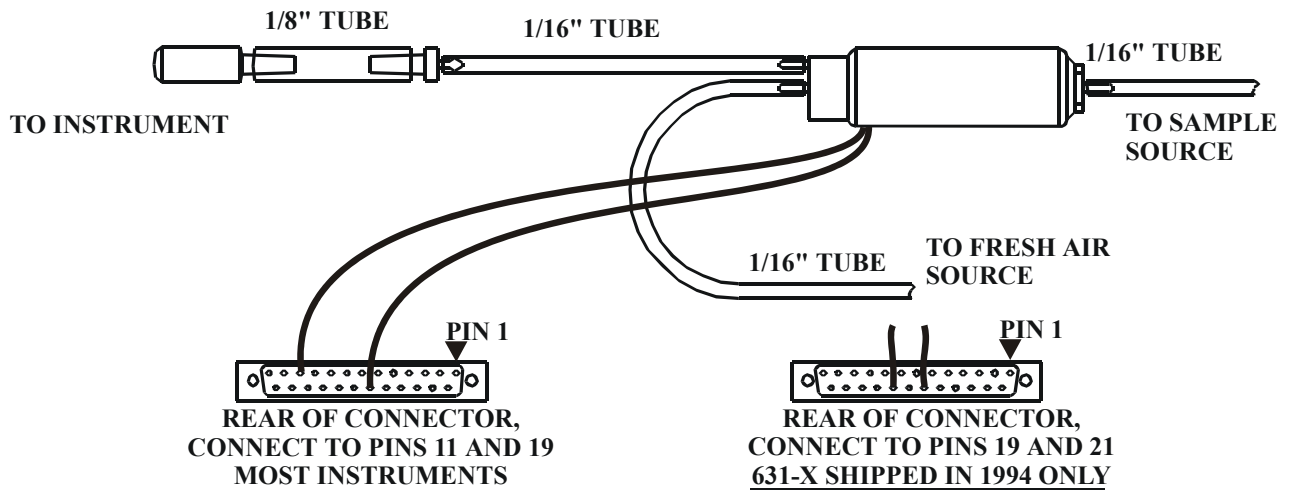

DC Power Operation

Instruments with the 631-X option board modification can be used with any +12 VDC source for continuous operation, if the AZI Power Inverter Kit, P/N Y031 0902 is installed along with the option board. To preserve the life of the DC power source, usually a car or truck battery, the power inverter will switch on automatically to supply the AC necessary for regeneration only. The external switch on the inverter should always be OFF to preserve battery life during normal sampling.

To work with the power inverter kit, place option board SW100 DIP Switch #6 to the ON position.

When the instrument starts a regeneration with option board SW100 DIP Switch #6 ON, the instrument sends a signal to close the relay on the DC Power Adaptor, AZI P/N 1000 0089, mounted between the data logger and the instrument. This switches the power inverter ON using the inverter's internal switch.

NOTE: When this mode is enabled, the instrument does NOT check for 115 VAC for the regeneration. If there is no AC power to the instrument, and a regeneration is initiated, the instrument will flash .H.H.H (rather than .P.P.P), however the sensor will not heat, nor will the sensor be cleaned.

DC Power Adaptor Kit, AZI P/N Y031 0902

- The DC power adaptor kit consists of:
 - DC Power Adaptor, P/N 1000 0089
 - DC Power Inverter, P/N 4000 1021
 - DC Power Cable Assembly, P/N 6000 1093

Installation

- Ensure that the instrument's option board switches are set correctly for the intended operation with the option board's SW100 DIP Switch #6 set to "ON" for DC operation.
- Mount the interface board to the rear of the instrument. Tighten the mounting screws.
- Place or mount the DC/AC power inverter in a secure position near the instrument.
- Connect the cable from the DC/AC power inverter to the matching connector on the interface board. Note that the connectors are keyed to prevent improper connection.
- Plug the instrument's AC power cord into the power inverter and connect it to the instrument.

Ensure that the inverter's power switch is in the "OFF" position. LEAVE the power switch in the "OFF" position at all times. The interface board will activate the inverter when necessary. If the inverter power switch is placed in the "ON" position, it will cause a continuous drain on the external 12-volt power system.

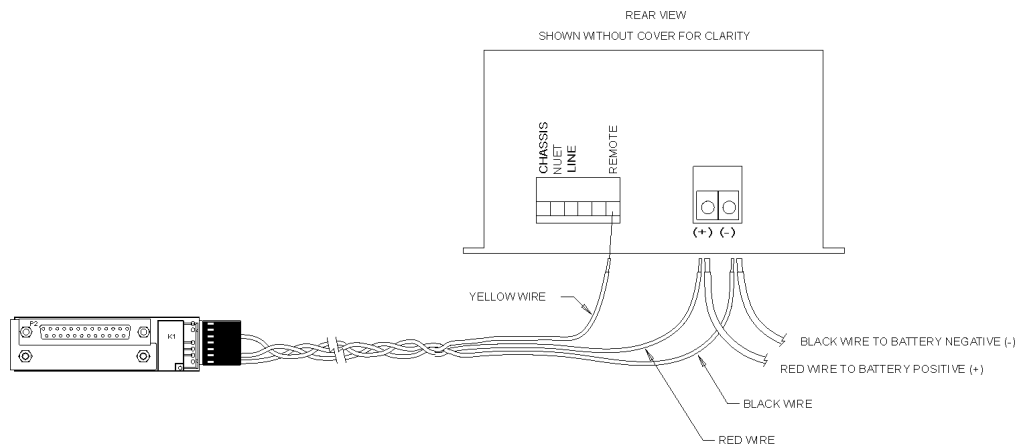

- Remove the screws from the rear cover of the inverter and remove the cover.
- Place the wires from the external DC source (battery) and the wires from the DC power cable through the holes in the end plate.
- Connect cables from the external 12-volt power source and the DC power cable assembly to the appropriate positive (+) and negative (-) terminals on the back of the inverter and tighten the hold down screws.
- Connect the yellow wire from the DC power cable to the "REMOTE" terminal on the power inverter and tighten the hold down screw.
- Reinstall the cover.
- If the external 12volt lines are not powered, power them now. (Connect them to the battery)
- Connect the instrument's AC power cord between the instrument and the front of the power inverter.
- Turn the instrument "ON."
- Press the "REGEN" switch on the instrument. Inverter operation can be verified in either of two ways:
 - Immediately after pressing "REGEN" the inverter will intermittently "sing." This tone slowly becomes nearly continuous and then ends after 64 seconds.
 - If the area is noisy, use a voltmeter or test lamp to verify that approximately 115 volts is present for about 64 seconds, starting when the "REGEN" switch is pressed.
- Allow the instrument to complete its regeneration before turning it off.
- With the instrument turned off, complete the installation (i.e. connect data logger, communications cables, or other devices and ensure that the DIP switches for the instrument and option board are set correctly.

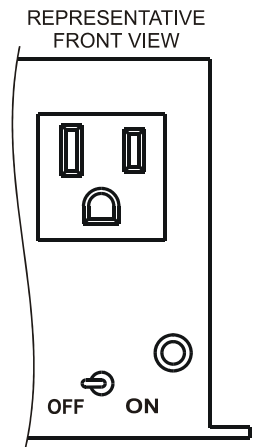

15. APPENDIX E: CALCULATION OF DYNACALIBRATOR H₂S CONCENTRATION

UNIT DEFINITIONS

mole $\equiv 6.02 \cdot 10^{23}$ molecules

nanogram (ngm) = $\frac{\text{gm}}{10^9}$

PPM_v $\equiv 10^{-6}$

CALCULATIONS

$$\frac{(\text{molar volume @ } 25 \text{ }^\circ\text{C}) * (\text{tube permeation rate})}{\frac{(\text{molecular weight of H}_2\text{S})}{(\text{total gas flow rate})}} = \text{PPM}_{\text{volume/volume}}$$

$$\frac{\left(24.45 * \frac{\text{ltr}}{\text{mole}}\right) * \left(5090 * \frac{\text{ngm}}{\text{min}}\right)}{\left(34.07 * \frac{\text{gm}}{\text{mole}}\right) * \left(7138 * \frac{\text{ml}}{\text{min}}\right)} = 0.512 \text{ PPM}_v$$

Mole units divide out, as do mass units, leaving volume per minute in both the numerator and the denominator. This leaves a unitless quantity scaled by 1×10^6 in the denominator that is the definition of PPM.

16. WARRANTY

Arizona Instrument LLC (seller) warrants to buyer that Jerome products delivered pursuant to this agreement shall, at the time of delivery, and for a period of one (1) year. Thereafter (the Internal Battery Pack, where applicable, is warranted for a period of ninety [90] days only), to be free from defects in material or workmanship and shall conform to seller's specifications or such other specifications as seller has agreed to in writing. Seller's obligations with respect to claims under this warranty shall be limited, at seller's option, either to the replacement of defective or non-conforming product or to an appropriate credit for the purchase price thereof subject to the provisions of seller's Warranty Policy as amended from time to time, said Policy being incorporated herein by reference.

Returned products under warranty claims will be shipped to seller's plant by buyer at buyer's expense and shall be accompanied by a statement of the reason for the return and an approved Return Material Authorization Number issued by seller. Buyer remains responsible for payment for products not accepted for warranty adjustment, handling costs, and freight costs associated therewith.

Notwithstanding the foregoing, no warranty shall be enforceable in the event that product has been subjected to environmental or stress testing by buyer or any third party without written approval of seller prior to such testing. Further, no warranty shall be enforceable if the alleged defect is found to have occurred because of misuse, neglect, improper installation, repair, alteration, accident, or improper return handling procedure by buyer.

Discontinued product is warranted only for a credit or replacement at seller's option.

THE EXPRESS WARRANTIES GRANTED ABOVE SHALL EXTEND DIRECTLY TO BUYER AND NOT TO BUYER'S CUSTOMERS, AGENTS, OR REPRESENTATIVES AND, EXCEPT FOR WARRANTY OF TITLE, IS IN LIEU OF ALL OTHER WARRANTIES, WHETHER EXPRESSED OR IMPLIED, INCLUDING ANY IMPLIED WARRANTIES OF FITNESS FOR A PARTICULAR PURPOSE AND MERCHANTABILITY, SUCH OTHER WARRANTIES BEING SPECIFICALLY DISCLAIMED BY SELLER. IN NO EVENT SHALL EITHER PARTY'S LIABILITY FOR ANY BREACH OR ALLEGED BREACH OF THIS AGREEMENT EXCEED THE TOTAL EXTENDED PRICE OR PRICES SHOWN ON UNFILLED ORDERS, NOR SHALL EITHER PARTY BE LIABLE FOR ANY SPECIAL, INCIDENTAL OR CONSEQUENTIAL DAMAGES RESULTING FROM BREACH OR ALLEGED BREACH.

Notwithstanding the foregoing, if any product covered by order(s) placed hereunder is designated as "developmental," "prototype" or "experimental," no warranty whatsoever except a warranty of title to component materials, will be applicable thereto and buyer shall indemnify seller for any claims for liability asserted seller in connection therewith.

The foregoing state the entire liability of seller in connection with products supplied hereunder.

TRADEMARK AND COPYRIGHT PROTECTION

Jerome Instrument, Arizona Instrument, AZI and the stylized AZI are all registered trademarks of Arizona Instrument LLC.

Copyright 1990-2003, Arizona Instrument LLC. All Rights Reserved.

Resisorb™ is a registered trademark of J.T. Baker Chemical Company
Tygon™ is a registered trademark of Norton.

Arizona Instrument LLC
Jerome 631-X Hydrogen Sulfide Analyzer Operation Manual
Part Number 700-0037
January 2003

If you have any questions regarding the operation of this instrument, please call our toll free number (800) 528-7411. Internationally, call (602) 470-1414 or fax (602) 470-1888.