



# Sno-Thro.®

## Parts Manual

### Models

924116 - 1028  
924117 - 1024  
924300 - 1024  
924505 - 1332  
924506 - 1336  
924507 - 936  
924508 - 1128

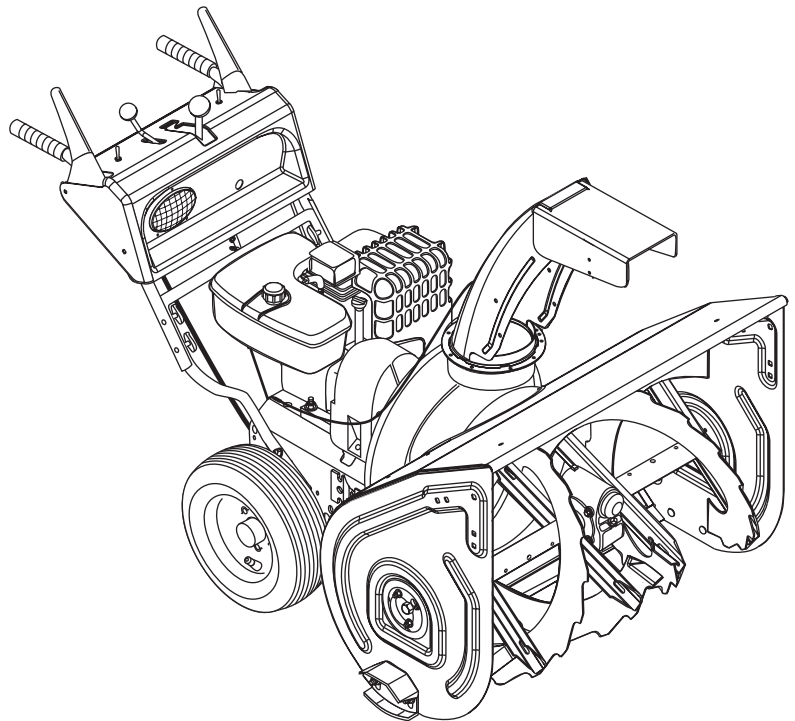

## THE MANUAL

---

Before you operate your unit, carefully and completely read manuals supplied with the unit. The contents will provide you with an understanding of safety instructions and controls during normal operation and maintenance.

For your safety and the safety of others always read, understand, and follow all DANGER, WARNING, and CAUTION messages found in manuals and on safety decals.

Hardware descriptions are given in decimals.

Decimals to Fractions			
.063	1/16	.563	9/16
.125	1/8	.625	5/8
.188	3/16	.688	11/16
.250	1/4	.750	3/4
.313	5/16	.813	13/16
.375	3/8	.875	7/8
.438	7/16	.938	15/16
.500	1/2	1.00	1

## SERVICE AND REPLACEMENT PARTS

---

When ordering replacement parts or making service inquiries, know the Model and Serial numbers of your unit and engine.

Numbers are located on the product registration card in the unit literature package. They are printed on a serial number label, located on the frame of your unit.

- Record Unit Model and Serial numbers here:

- Record Engine Model and Serial numbers here:

## UNAUTHORIZED REPLACEMENT PARTS

Use only Ariens replacement parts. The replacement of any part on this vehicle with anything other than an Ariens authorized replacement part may adversely affect the performance, durability, or safety of this unit and may void the warranty. disclaims liability for any claims or damages, whether warranty, property damage, personal injury or death arising out of the use of unauthorized replacement parts.

## PRODUCT REGISTRATION

---

A warranty registration card must be filled out, signed, and returned at time of purchase. This card activates the warranty. Claims meeting requirements during limited warranty period will be honored.

## YOUR SATISFACTION IS IMPORTANT

---

**Questions? Please follow these helpful steps:**

1. Refer to the manuals supplied with your unit.  
They will guide you through safe and proper operation and maintenance.  
They contain specifications on your unit.  
If your questions are not answered in these manuals, go to step number two.
2. Contact Your Dealer.  
Our dealers will be happy to supply any service or advice required to keep your unit operating at peak efficiency.  
A factory trained staff is available to support your equipment needs. They stock genuine Ariens parts and lubricants manufactured with the same precision and skill as the original.  
If your questions are not resolved by the support staff, ask for the manager or owner.  
When contacting your Dealer supply your model and serial numbers.

## TO SPEED PARTS ORDERING:

1. Know the model and serial numbers of your unit.
2. Know the part number required.
3. Know the quantity required.
4. Know the part description.

## MODELS

---

### Domestic

#### Model 924116 (1028)

10 H.P. 28" Sno-Thro  
Serial No. 000101 and up

#### Model 924117 (1024)

10 H.P. 24" Sno-Thro  
Serial No. 000101 and up

### International

#### Model 924300 (1024)

10 H.P. 24" Sno-Thro  
Serial No. 000101 and up

### Global

#### Model 924505 (1332)

13 H.P. 32" Sno-Thro  
Serial No. 000101 and up

#### Model 924506 (1336)

13 H.P. 36" Sno-Thro  
Serial No. 000101 and up

#### Model 924507 (936)

9 H.P. 36" Sno-Brush  
Serial No. 000101 and up

#### Model 924508 (1128)

11 H.P. 28" Sno-Thro  
Serial No. 000101 and up

## TABLE OF CONTENTS

---

### DECALS

---

Decals . . . . . 4

### ENGINE AND DRIVE

---

Engine and Belt Drive . . . . . 6

### MAIN FRAME

---

Speed Selector and Frame . . . . . 8  
Wheels and Axle . . . . . 10  
Reduction Drive . . . . . 12  
Friction Wheel Drive . . . . . 13

### OPERATORS CONTROLS

---

Handlebars Lever Controls, Panel and Dash . . . . . 14  
Cables and Controls . . . . . 16

### BLOWER

---

Chute, Auger and Battery . . . . . 18  
Gear Case-Aluminum . . . . . 21  
Gear Case-Cast Iron . . . . . 22  
Discharge Chute Crank . . . . . 24  
Electric Discharge Chute . . . . . 26

### BRUSH

---

Brush Head . . . . . 28  
Brush Drive Unit . . . . . 30

### ELECTRICAL SYSTEMS

---

Electrical . . . . . 32  
Continuity Diagrams . . . . . 33  
Wiring Diagrams . . . . . 34

# DECALS

Model 924116, 117, 300, 505, 506, 508

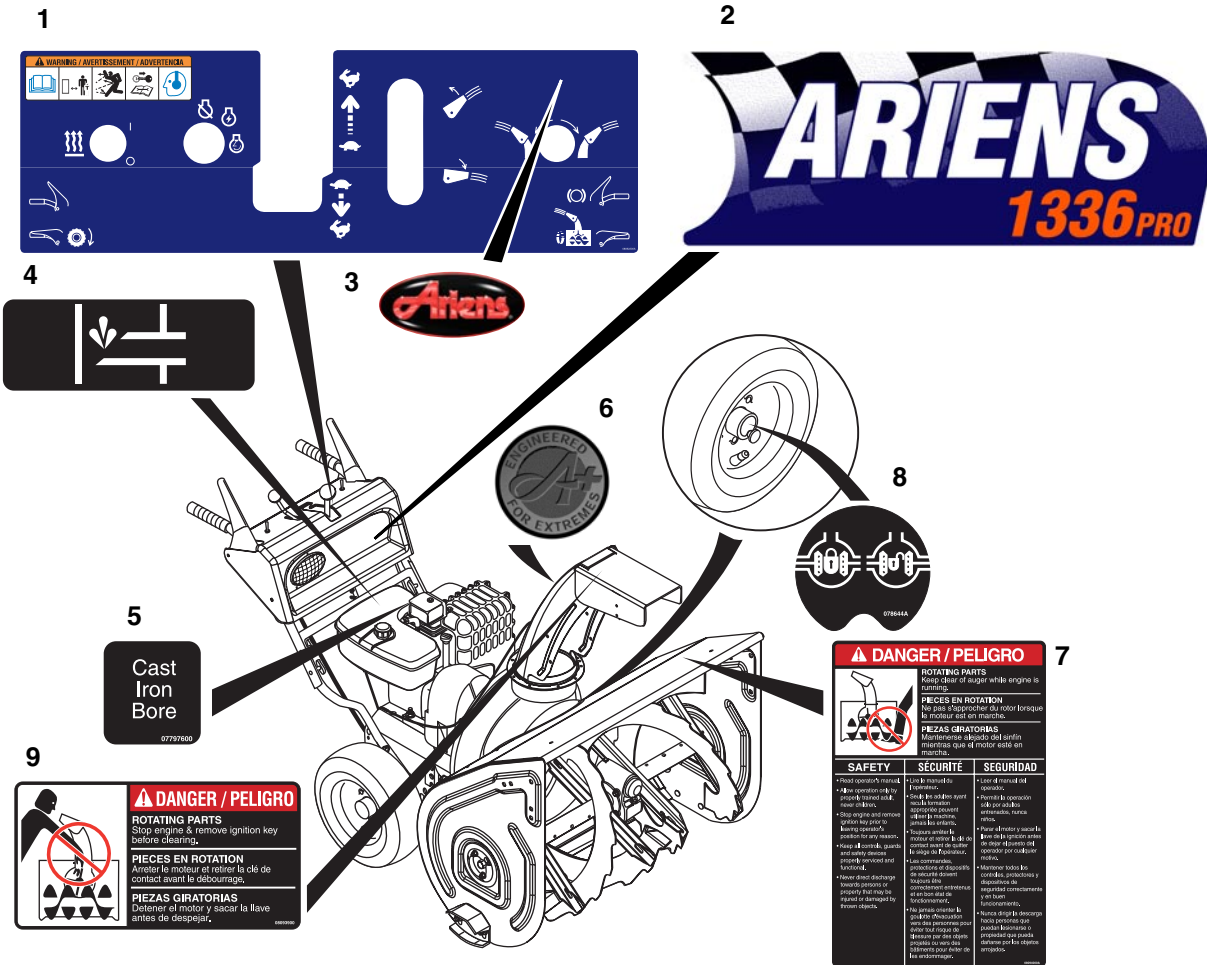

Item	Part No.	Qty.	Description
1	08092200	1	Decal, 1332/1336 Control (505, 506)
	08092300	1	Decal, 1024/1128 Control (300, 508)
	08092400	1	Decal, 1024 Control (117)
	08092500	1	Decal, Control 1028 (116)
2	08092700	1	Decal, Front Panel- 1336 (506)
	08092800	1	Decal, Front Panel- 1332 (505)
	08092900	1	Decal, Front Panel- 1128 (508)
	08093000	1	Decal, Front Panel- 1024 (117, 300)
	08093100	1	Decal, Front Panel- 1028 (116)
3	07746400	1	Decal, Ariens Jewel
4	07733900	1	Decal, Primer
5	07797600	1	Decal, Cast Iron Bore
6	07751100	1	Decal, A+
7	08094000	1	Decal, Danger
8	07864400	1	Decal, Differential Lock
9	08093900	1	Decal, Danger - Rotating Parts

PS0415

# DECALS

Model 924507

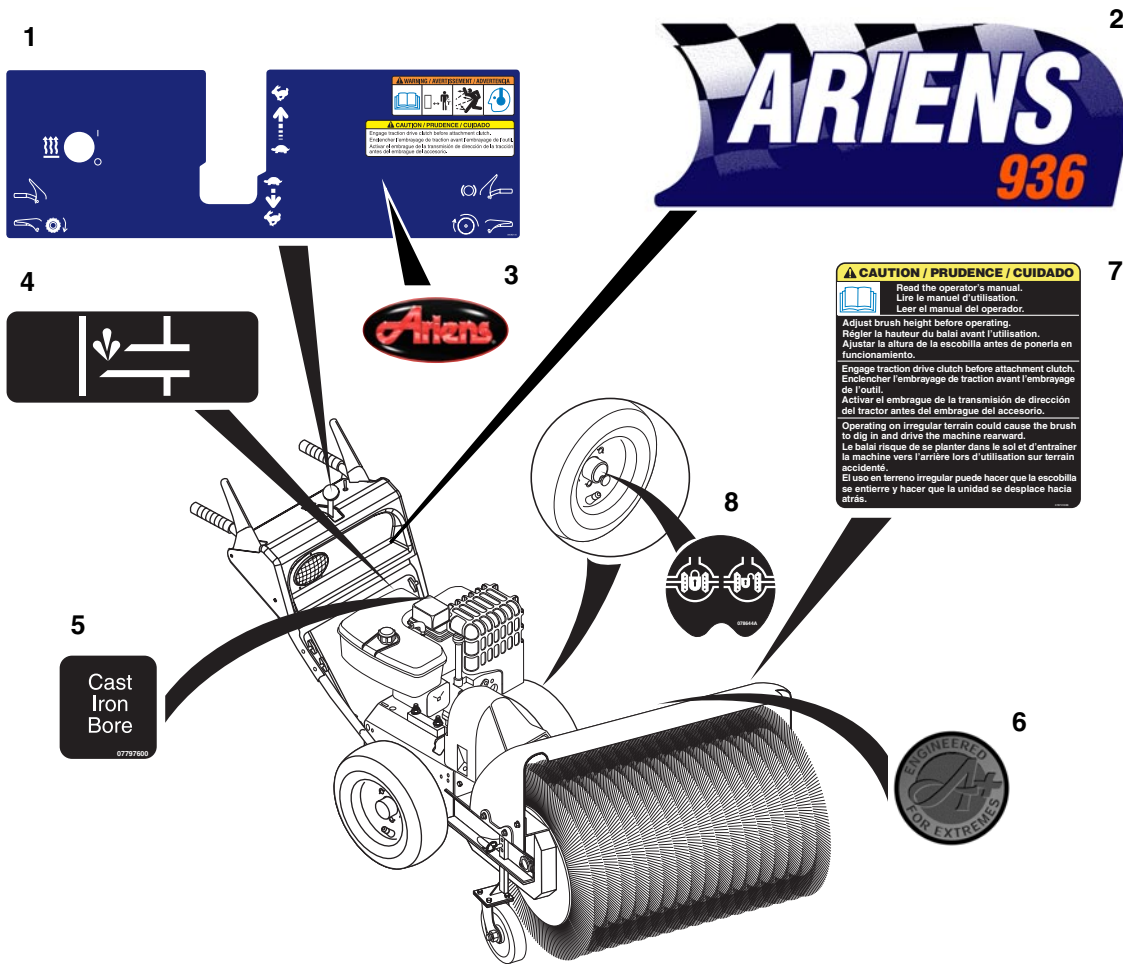

Item	Part No.	Qty.	Description
1	08092100	1	Decal- 936 Control
2	08092600	1	Decal- 936 Dash
3	07746400	1	Decal-Ariens Jewel
4	07733900	1	Decal-Primer
5	07797600	1	Decal- Cast Iron Bore
6	07751100	1	Decal-A+
7	07873100	1	Decal, Caution
8	07864400	1	Decal-Differential Lock

PS0871

# ENGINE AND BELT DRIVE

Model 924116, 117, 300, 505, 506, 507, 508

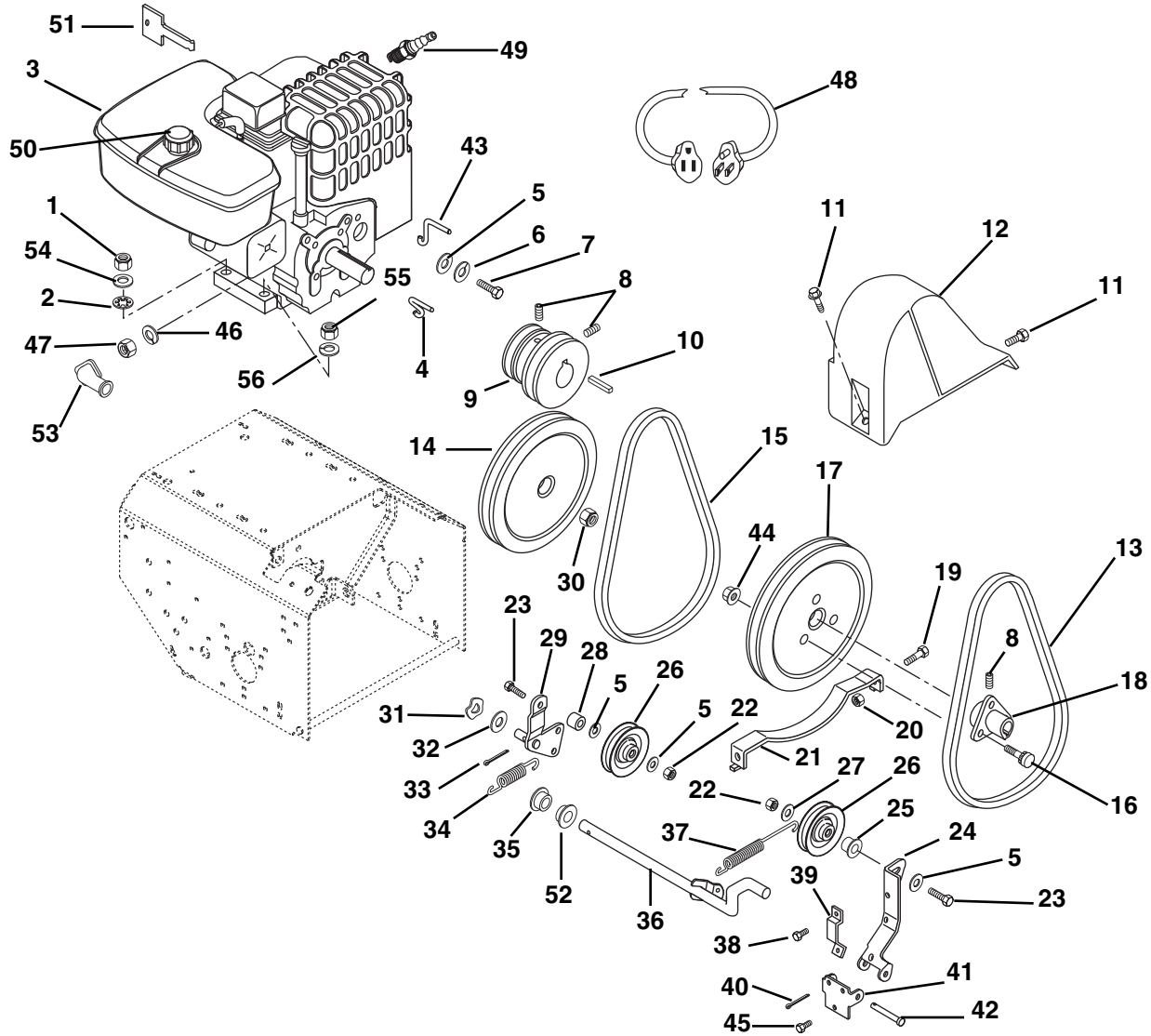

PS0448

Item	Part No.	Qty.	Description
1	06529800	1	Nut-Locking-Center .31-18
2	06310500	1	Washer-Lock Internal .31
3	08262200	1	Engine, 10HP L Head Tecumseh - 120 Volt (116)
	08260700	1	Engine, 10HP OHV Tecumseh- 120 Volt (117)
	08260800	1	Engine, 10HP OHV Tecumseh- 12 Volt (300)
	08261000	1	Engine, 11HP Tecumseh OHV 12 Volt (508)
	08261100	1	Engine, 13HP Tecumseh 12 Volt (505, 506)
	08261200	1	Engine, 9HP Tecumseh OHV (507)
4	02410900	1	Belt Finger
5	06435700	5	Washer-Flat-Steel .38 x .88 x .083
6	06308600	2	Washer-Locking .31 x .078
7	05947300	2	Bolt-Hex .31-24 x .75 Grade 5
8	06005500	4	Screw-Set .31-18 x .38
9	02489100	1	Engine Sheave (116, 117, 300, 505, 507, 508)
	02435700	1	Engine Sheave (506)

# ENGINE AND BELT DRIVE

Model 924116, 117, 300, 505, 506, 507, 508

Item	Part No.	Qty.	Description
10	06601800	1	Key-Straight .25 x 1.75 x .25
11	07412000	2	Screw-Tap .25-20 x .50
12	02489000	1	Belt Cover
13	07238500	1	V-Belt (116)
	07238400	1	V-Belt (117, 300, 508, 507)
	07238300	1	V-Belt (505)
	07236200	1	V-Belt (506)
14	07325700	1	Pulley-V 8.40 x 1.0 with Key
15	07211200	1	V-Belt -Traction Drive (116, 117, 300, 507, 508)
	07236100	1	V-Belt -Traction Drive (505, 506)
16	07005300	3	Bolt-Serrated Round Head Slotted .31-18 x .75
17	07307000	1	Pulley-V 9.0 x 1.25
18	02438900	1	Hub (116, 117, 300, 505, 506, 508)
19	05947900	2	Bolt-Hex .25-20 x .50 Grade 5 (117, 300, 505, 506, 507, 508)
20	06529700	2	Nut-Locking-Center .25-20 (117, 300, 505, 506, 507, 508)
21	02423651	1	Belt Retainer (117, 300, 505, 506, 507, 508)
22	06529800	2	Nut-Locking Center .31-18
23	05947500	2	Bolt-Hex .31-18 x 1.25 Grade 5
24	02434851	1	Idler Arm
25	01213100	1	Bearing Spacer
26	02457400	2	Idler
27	06437200	1	Washer-Flat-Steel .34 x .69 x .065
28	01103100	1	Spacer
29	02453751	1	Idler Arm
30	06530300	1	Nut-Locking-Nylon .63-18
31	01026000	1	Wave Washer
32	06436500	1	Washer-Flat-Steel .38 x .81 x .023
33	06707000	1	Pin-Cotter .09 x 1.00
34	08309400	1	Spring-Tension .80 x .73 x 3.06
35	05503700	1	Bushing-Flange-Nylon .50 x .63 x .31 x .75
36	02442800	1	Activating Shaft
37	08317200	1	Spring-Tens .05 x .44 x 3.37
38	07412100	2	Screw-Tapping 10-24 x .38
39	02435300	1	Return Clip
40	06707400	1	Pin-Cotter .09 x .50
41	02434751	1	Bracket
42	02435400	1	Pin-Clevis
43	02411000	1	Belt Finger
44	06530400	3	Nut-Locking-Flange .31-18 (116, 117, 300, 506, 507, 508)
45	07411600	3	Screw-Tap .25-20 x .37
46	06306800	1	Washer-Lock-External .26 x .50 x .026 (505, 506)
47	06533200	1	Nut-Hex .25-20 (505, 506)
48	02483100	1	Cord-Extension-110V (116, 117)
49	21533500	1	Plug-Spark
50	07531800	1	Fuel Cap
51	07532000	1	Key, Push/Pull-Tecumseh (116, 117)
52	05502100	1	Bushing-Flange .50 x .63 x .50 x .75
53	07533200	1	Boot, Eyelet Terminal (300, 505, 506, 508)
54	06436700	1	Washer-Flat-Steel .32 x .63 x .062
55	06529200	3	Nut-Hex .31-18
56	06307400	3	Washer-Locking .31 x .097 Heavy

# SPEED SELECTOR AND FRAME

Model 924116, 117, 300, 505, 506, 507, 508

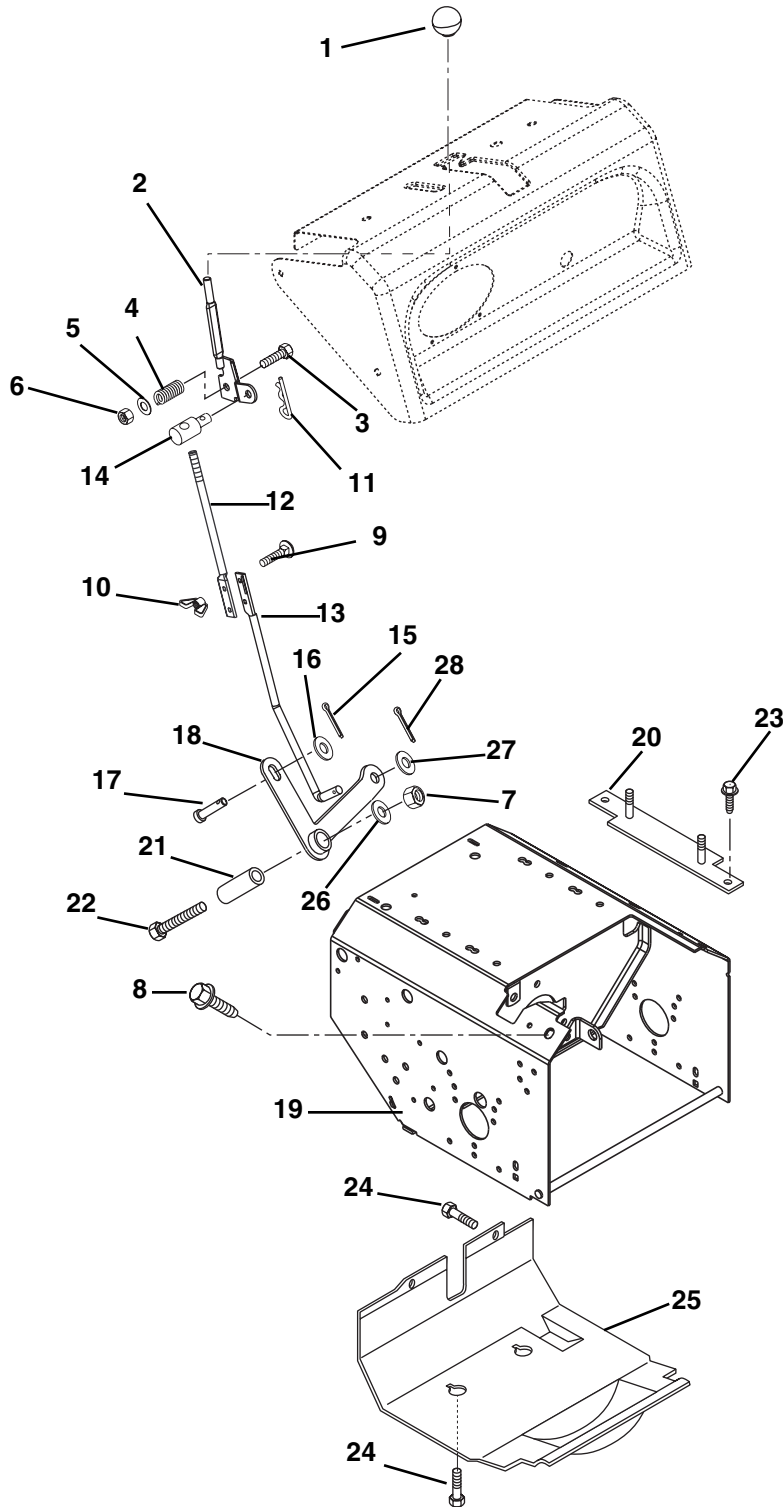



# SPEED SELECTOR AND FRAME

Model 924116, 117, 300, 505, 506, 507, 508

Item	Part No.	Qty.	Description
1	07533500	1	Knob, Ball-Black 1-.41, .38-16
2	02492551	1	Lever, Shift-Weldment
3	05962900	1	Bolt-Hex .38-16 x 2.25 Grade 5
4	08335700	1	Spring-Compression .13 x .78 x 1.25
5	06435900	1	Washer-Flat-Steel .44 x 1.00 x .083
6	06529600	1	Nut-Locking-Center .38-16
7	06529800	1	Nut-Locking-Center .31-18
8	07028500	2	Bolt-Hex Flanged Whiz Lock Head .38-16 x .75
9	06219800	2	Bolt-Round Head Square Neck .25-20 x 1.00 Grade 5
10	06537500	2	Nut-Locking Wing .25-20
11	06713500	1	Pin-Hair Internal .08 x .18 x 1.18
12	02492800	1	Rod, Shift-Upper
13	02487700	1	Rod, Shift-Lower
14	02493000	1	Pivot, Rod
15	06706900	1	Pin-Cotter .09 x .75
16	06436500	1	Washer-Flat-Steel .38 x .81 x .023
17	01215100	1	Clevis Pin .37/.38 x .69
18	02476300	1	Arm, Shift
19	02485359	1	Main Frame
20	02401800	2	Bolt Strap (116, 117, 300, 507, 508)
	02483500	2	Bolt Strap (505, 506)
21	05531500	1	Bushing-Sleeve .33 x .50 x .75
22	05947500	1	Bolt-Hex .31-18 x 1.25 Grade 5
23	07411600	2	Screw-Tapping .25-20 x .37 Hex Washer Head
24	07411500	4	Screw-Tapping .31-18 x .50 Hex Washer Head
25	02477159	1	Cover, Bottom
26	06437200	1	Washer-Flat-Steel .34 x .69 x .065
27	06441900	1	Washer-Flat-Steel .53 x 1.06 x .095
28	06707300	1	Pin-Cotter .12 x .75

# WHEELS AND AXLE

Model 924116

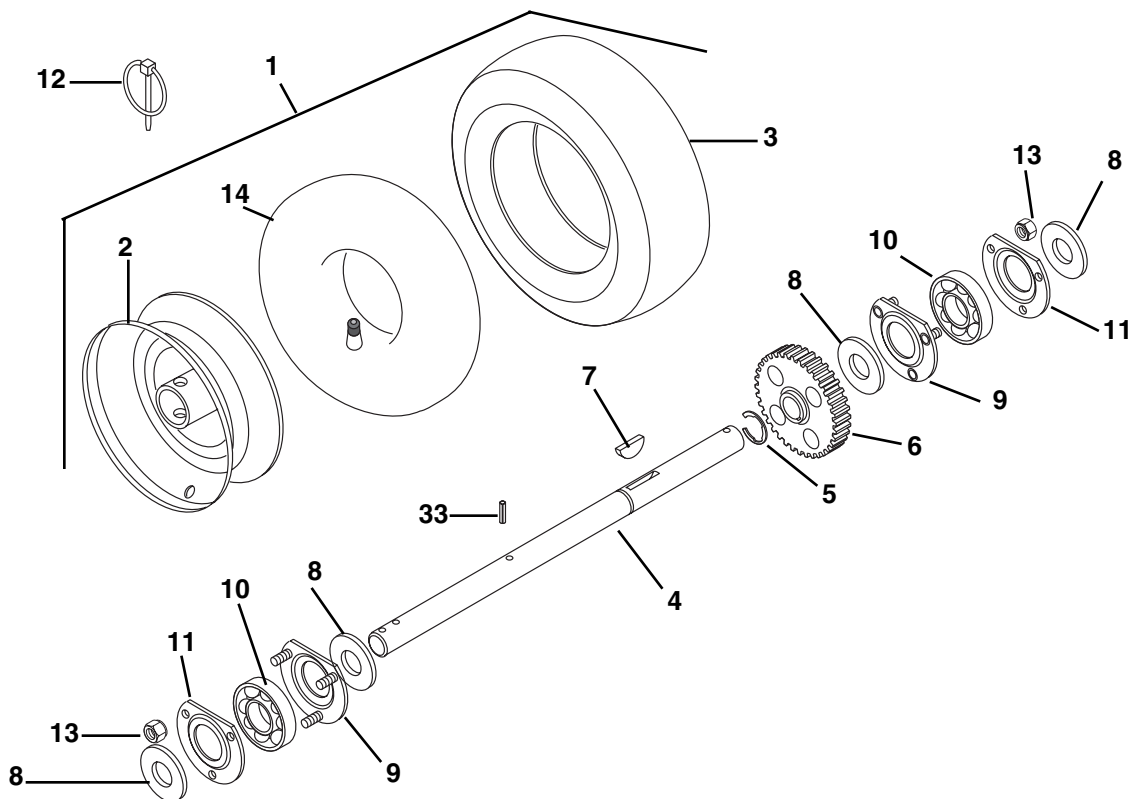

PS0800

Model 924117, 300, 505, 506, 507, 508

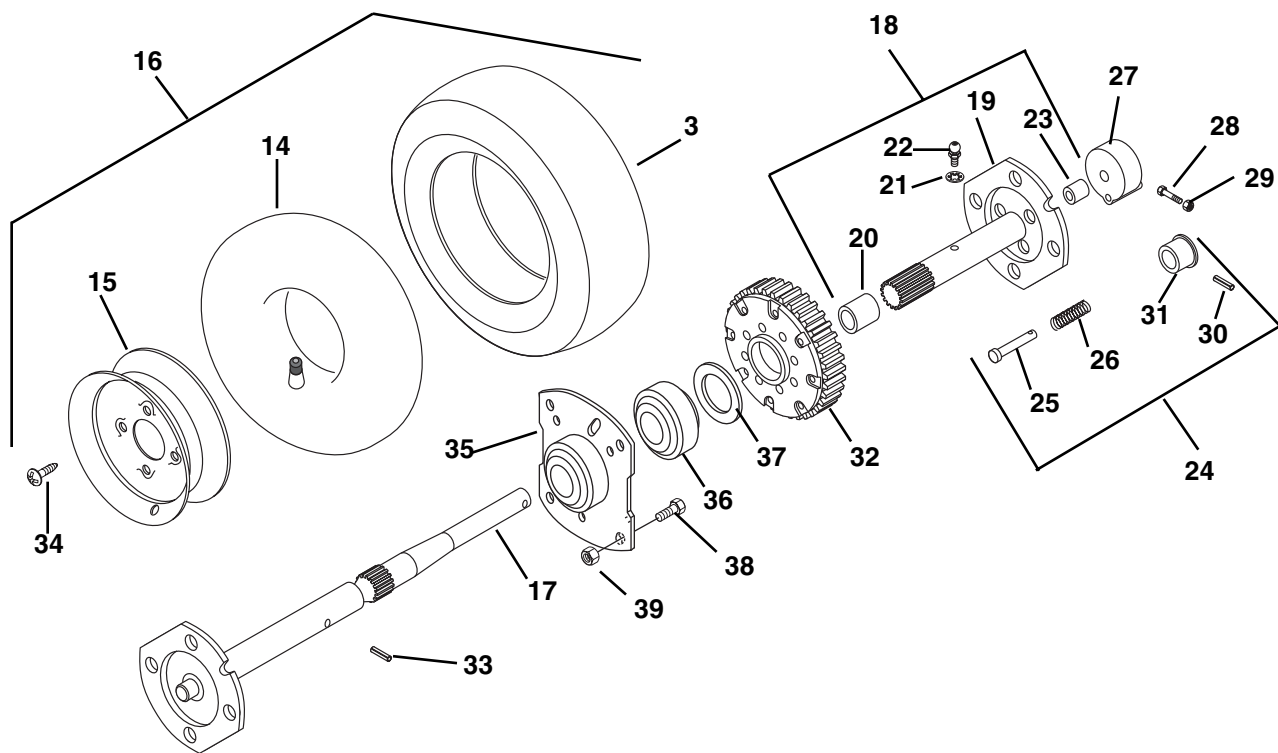

PS0790

# WHEELS AND AXLE

Model 924116, 117, 300, 505, 506, 507, 508

Item	Part No.	Qty.	Description
1	07150300	2	Tire/Wheel Assembly 16 x 6.50 - 8 (116)
2	07150500	2	Wheel 6.50 x 8.00 (116)
3	07121800	2	Tire 4.80-8 (117, 300)
	07121600	2	Tire 16 x 6.50-8 (116, 505, 506, 507, 508)
4	02483200	1	Shaft, Axle (116)
5	05718400	1	Ring, Retaining .88 x .05 (116)
6	02439600	1	Spur Gear (116)
7	06600800	1	Woodruff Key .25 x .88 x .38 (116)
8	06436900	4	Washer-Flat-Steel .88 x 1.25 x .062 (116)
9	00301700	2	Bearing Flange (116)
10	05409300	2	Bearing, Ball .88 x 1.75 x .50 (116)
11	01014200	2	Flange, Bearing (116)
12	07053700	2	Pin-Lock .31 x 1.75 (116)
13	06529700	6	Nut-Locking-Center .25-20 (116)
14	07103700	2	Tube 4.00 x 8 (117, 300)
	07108700	2	Tube 6.50 x 8 (116, 505, 506, 507, 508)
15	07107600	2	Wheel 4.80-8 (117, 300)
	07107700	2	Wheel 6.50-8 (505, 506, 507, 508)
16	07121900	2	Tire/Wheel Assembly #34-4.80/4.00 x 8 (117, 300)
	07121700	2	Tire/Wheel Assembly #35-16 x 6.50 (505, 506, 507, 508)
17	02437151	1	Axle-Right Hand (505, 506)
	02440951	1	Axle-Right Hand (117, 300, 507, 508)
18	52405400	AR	Axle Assembly-Left Hand (Contains Items 19-23) (505, 506)
	52405500	AR	Axle Assembly-Left Hand (Contains Items 19-23) (117, 300, 507, 508)
19	02437051	1	Axle-Left Hand (505, 506)
	02441051	1	Axle-Left Hand (117, 300, 507, 508)
20	05505700	1	Bushing-Sleeve .75 x .81 x .75 (117, 300, 505, 506, 507, 508)
21	06307000	1	Washer-Locking .25 x .05 (117, 300, 505, 506, 507, 508)
22	07012600	1	Fitting-Lube .25-28 x .26 (117, 300, 505, 506, 507, 508)
23	05502900	1	Bushing-Sleeve .56 x .63 x .63 (117, 300, 505, 506, 507, 508)
24	52405900	1	Lockout Hub Assembly (Contains Items 25-27, 30, 31) (117, 300, 505, 506, 507, 508)
25	01037400	1	Pin (117, 300, 505, 506, 507, 508)
26	08300700	1	Spring-Compression .03 x .34 x 1.06 (117, 300, 505, 506, 507, 508)
27	01037200	1	Lockout Hub (117, 300, 505, 506, 507, 508)
28	05948100	1	Screw-Cap .25-20 x 2.00 Grade 8 (117, 300, 505, 506, 507, 508)
29	06530900	1	Nut-Jam-Nylon .25-20 (117, 300, 505, 506, 507, 508)
30	05803200	1	Pin-Roll .09 x 1.00 (117, 300, 505, 506, 507, 508)
31	01037500	1	Knob (117, 300, 505, 506, 507, 508)
32	52405300	1	Differential Assembly (117, 300, 505, 506, 507, 508)
33	05803000	1	Pin Roll .19 x 1.50
34	07412200	8	Screw-Tap .50-20 x .62 Hex Head (117, 300, 505, 506, 507, 508)
35	02457859	2	Bearing Retainer (117, 300, 505, 506, 507, 508)
36	05417700	2	Bearing-Ball 1.13 x 2.19 x .63 (117, 300, 505, 506, 507, 508)
37	06437400	2	Washer-Flat-Steel 1.14 x 1.72 x .13
38	07028600	8	Bolt Serrated Neck Slotted .25-20 x .50
39	06530100	8	Nut-Locking-Flange .25-20

# REDUCTION DRIVE

Model 924116, 117, 300, 505, 506, 507, 508

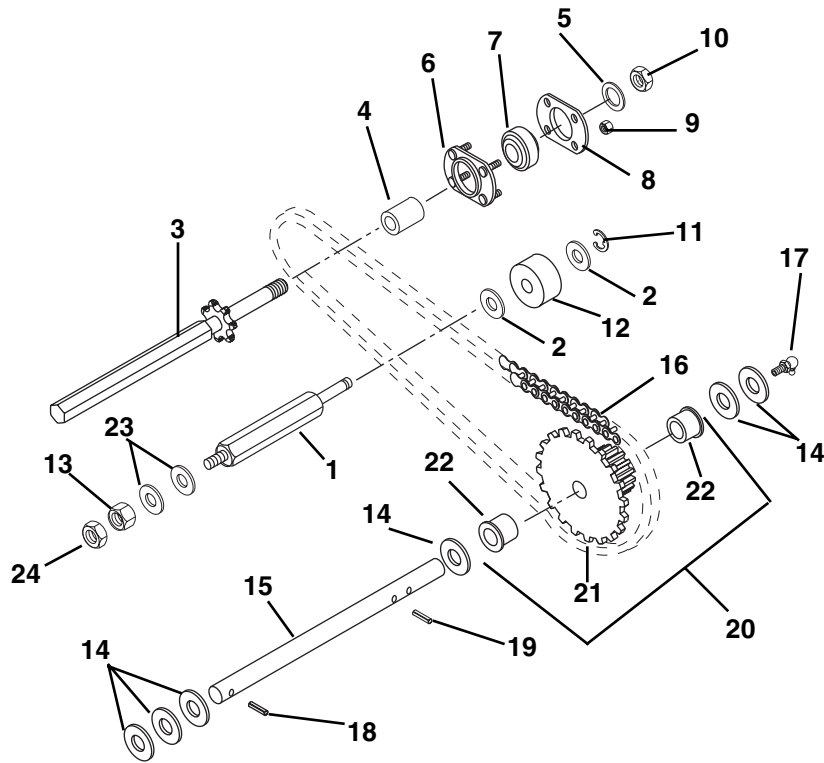

PS0463

Item	Part No.	Qty.	Description
1	02477300	1	Hex Shaft
2	06437200	2	Washer-Flat-Steel .34 x .69 x .065
3	02476800	1	Hex Shaft
4	05531600	1	Spacer .45 x .75 x 1.60
5	06436600	1	Washer-Flat-Steel .51 x .88 x .072
6	00308500	1	Bearing Flange
7	05435200	1	Bearing-Ball .44 x 1.38 x .44
8	02414100	1	Bearing Flange
9	06530600	4	Nut-Locking Dual Face 10-24
10	06536400	1	Nut-Locking-Center .44-14
11	05718300	1	Ring-Retaining External .31 x .025
12	07530500	1	Idler
13	06529800	1	Nut-Locking-Center .31-18
14	06436100	6	Washer-Flat-Steel .630 x 1.01 x .062
15	02436700	1	Pinion Shaft
16	02477700	1	Roller Chain #41-34 Pitches
17	07029700	1	Drive Fitting-Hydraulic
18	05802900	1	Pin Roll .16 x 1.00
19	05800900	1	Pin, Roll .13 x 1.00
20	52403200	1	Pinion and Sprocket Assembly (Contains Items 21, 22)
21	02436800	1	Pinion and Sprocket
22	05502600	2	Bushing-Flange .63 x .75 x .50 x .88
23	06435700	2	Washer-Flat-Steel .38 x .88 x .083
24	06536100	1	Nut, Jam .31-18

# FRICION WHEEL DRIVE

Model 924116, 117, 300, 505, 506, 507, 508

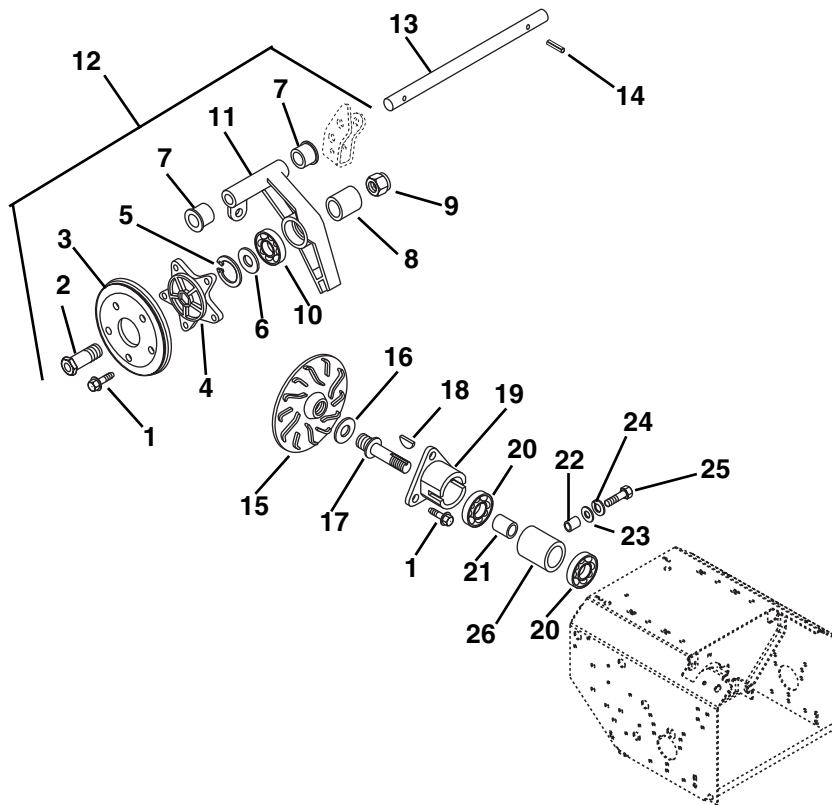

PS0452

Item	Part No.	Qty.	Description
1	07411500	8	Screw-Tapping .31-18 x .50
2	02445500	1	Spindle Hub
3	00300300	1	Friction Disc
4	02445400	1	Disc Hub
5	05702100	1	Ring-Retaining-Internal 1.75 x .062
6	06436900	1	Washer-Flat-Steel .88 x 1.25 x .062
7	05502600	2	Bushing-Flange .63 x .750 x .50 x .88
8	05512600	1	Bushing-Sleeve .88 x 1.25 x .53
9	06530500	1	Nut-Locking-Nylon .88-14
10	05409300	1	Bearing-Ball .88 x 1.75 x .50
11	02444500	1	Carrier
12	52404600	AR	Friction Wheel Assembly (Contains 1-11)
13	02477000	1	Carrier Shaft
14	05802900	2	Pin-Roll .16 x 1.00
15	01054600	1	Drive Plate
16	02407100	1	Drive Disc Spacer 1.30 x .76 x .19
17	02407600	1	Spindle
18	06600600	1	Key-Woodruff .13 x .50 x .20
19	02458200	1	Housing Mount
20	05435100	2	Bearing .63 x 1.38 x .43
21	02415500	1	Bearing Spacer
22	00303400	1	Roller
23	06437200	1	Washer-Flat-Steel .34 x .69 x .065
24	06308600	1	Washer-Lock .31 x .078
25	05946900	1	Bolt-Hex .31-18 x 1.00 Grade 5
26	02458100	1	Spindle Housing

# HANDLEBARS, LEVER CONTROLS, PANEL AND DASH

Model 924116, 117, 300, 505, 506, 507, 508

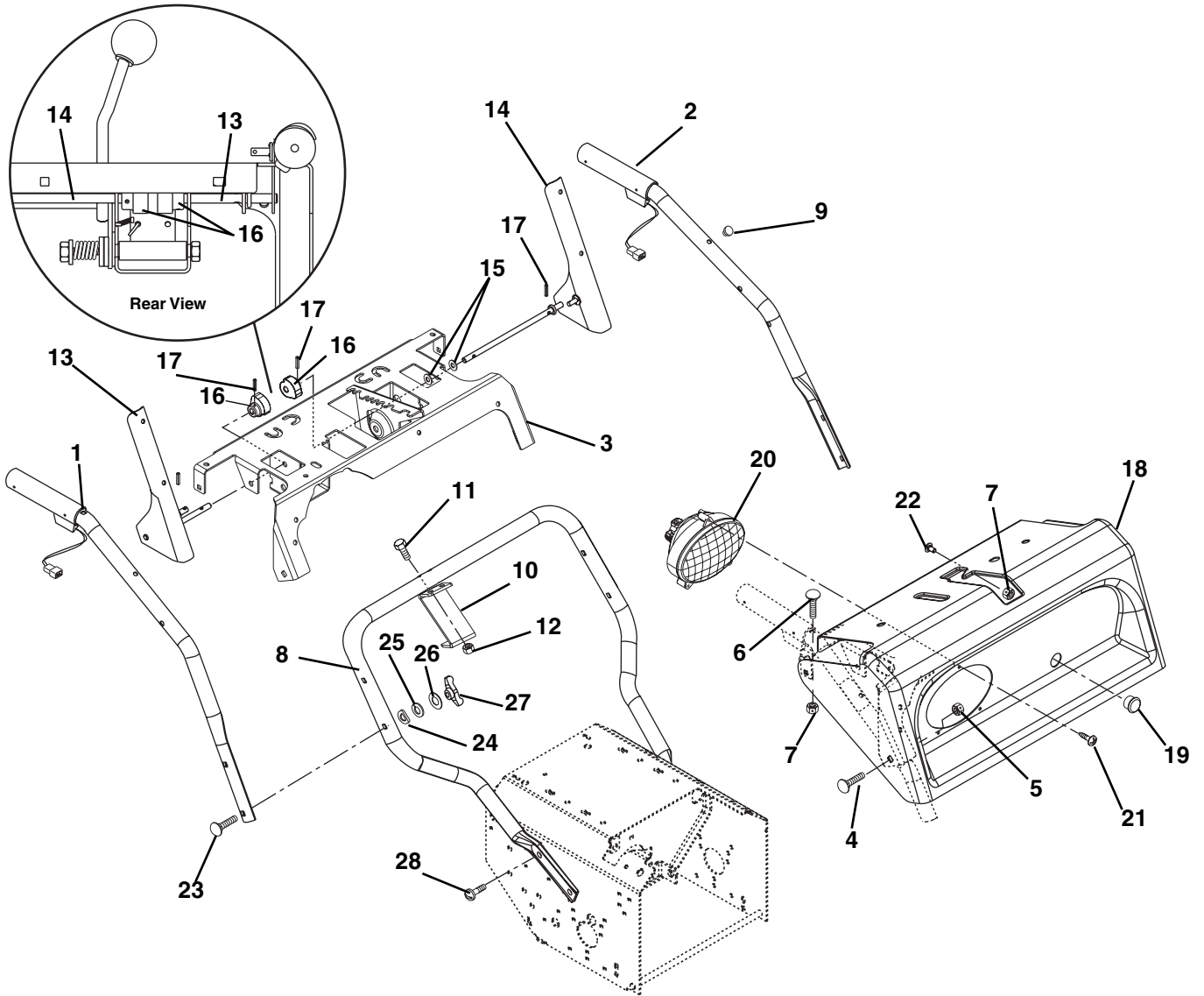

PS0813

# HANDLEBARS, LEVER CONTROLS, PANEL AND DASH

---

Model 924116, 117, 300, 505, 506, 507, 508

Item	Part No.	Qty.	Description
1	52415100	1	Handlebar, Upper Right Hand (Includes Hand Warmer)
2	52415200	1	Handlebar, Upper Left Hand (Includes Hand Warmer)
3	02491651	1	Panel, Sub-Weldment
4	06212100	2	Bolt-Round Head Square Neck .31-18 x 1.50 Grade 5
5	06529800	2	Nut-Locking-Center .31-18
6	06220100	2	Bolt-Round Head Square Neck .25-20 x 1.25
7	06529700	7	Nut-Locking-Center .25-20
8	02491851	1	Handlebar, Lower
9	07511800	2	Bumper
10	02486451	1	Bracket, Cable Support (116, 505, 506)
11	05952500	2	Bolt-Hex .25-20 x 1.50 Grade 5 (116, 505, 506)
12	06529700	2	Nut-Locking-Center .25-20 (116, 505, 506)
13	02493100	1	Lever, Right Hand-Coated
14	02493200	1	Lever, Left Hand-Coated
15	06437200	4	Washer-Flat-Steel .34 x .69 x .065
16	02492100	2	Cam, Interlock
17	05803400	4	Pin-Roll .125 x .75
18	52415300	AR	Panel with Decal - 936 (507)
	52415400	AR	Panel with Decal - 1024 (117)
	52415500	AR	Panel with Decal - 1028 (116)
	52415600	AR	Panel with Decal - 1332 (505)
	52415700	AR	Panel with Decal - 1024 (300)
	52415800	AR	Panel with Decal - 1128 (508)
	52415900	AR	Panel with Decal - 1336 (506)
19	07511200	1	Bushing, Snap (116, 117, 300, 508)
20	02485000	1	Headlamp, Oval with 1156 Bulb
21	07416700	3	Screw-Tapping 10-16 x .75 Hi-Lo
22	06214300	5	Bolt-Round Head Square Short Neck.25-20 x .50
23	06221600	4	Bolt-Round Head Square Neck .31-18 x 2.25
24	06446800	4	Washer, Saddle-.32 x .94 x .062
25	06307400	4	Washer-Locking .31 x .097 Heavy
26	06439400	4	Washer-Flat-Steel .33 x .88 x .062
27	07531700	4	Knob- Wing .31-18
28	07028500	4	Bolt-Screw Hex Flanged Whiz Lock Head .38-16 x .75

# CABLES AND CONTROLS

Model 924116, 117, 300, 505, 506, 507, 508

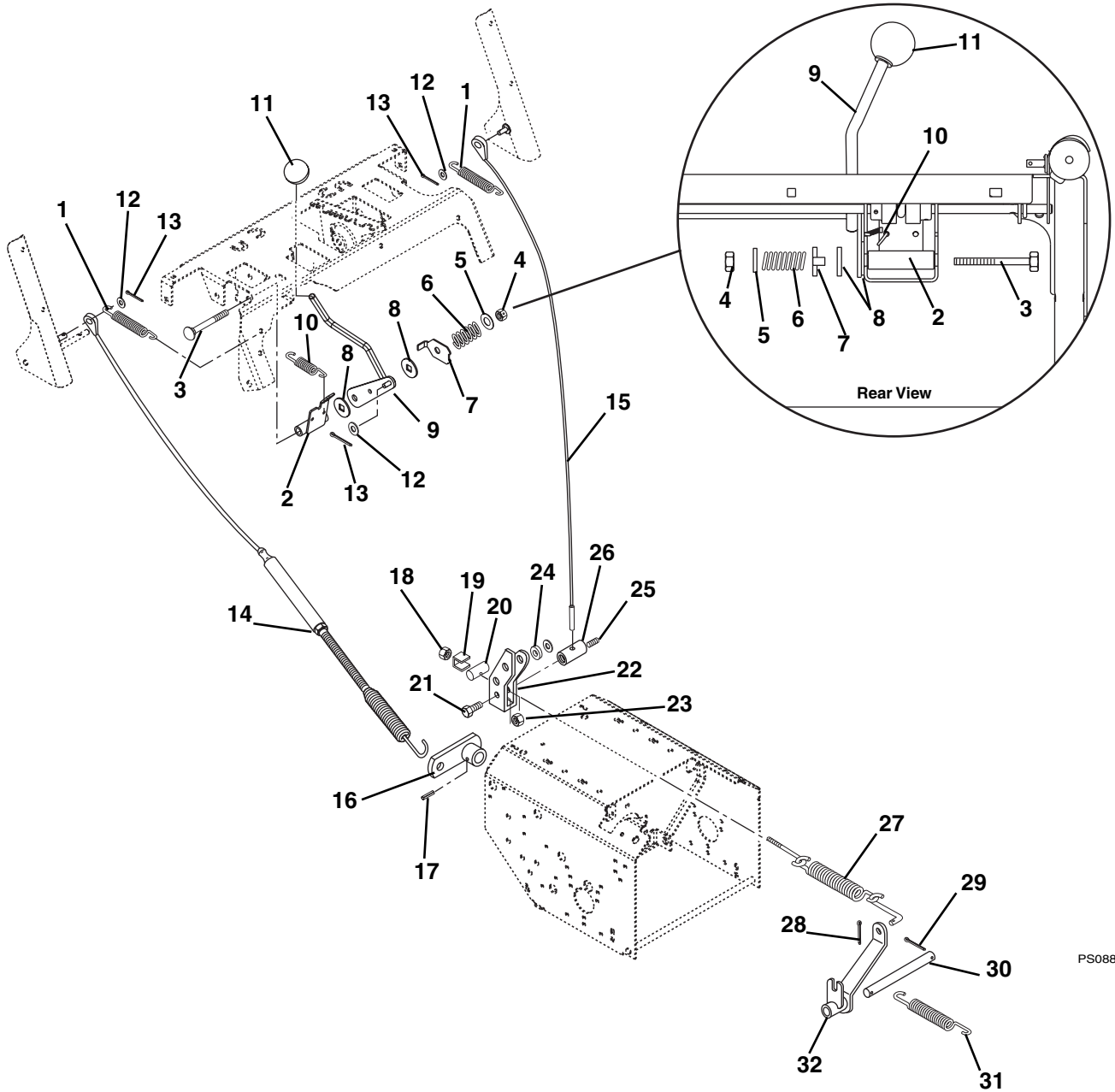

PS0880



# CABLES AND CONTROLS

Model 924116, 117, 300, 505, 506, 507, 508

Item	Part No.	Qty.	Description
1	08337100	2	Spring-Tension .056 x .50 x 3.76
2	02492200	1	Arm, Interlock
3	05970400	1	Bolt-Hex .38-16 x 4.50 Grade 5 (116, 505, 506)
	05957800	1	Bolt-Hex .38-16X3.00 Grade 5 (117, 300, 507, 508)
4	06529600	1	Nut-Locking-Center .38-16
5	06436200	1	Washer-Flat-Steel .41 x .81 x .065 (116, 505, 506)
6	08320900	1	Spring-Compression .19 x .56 x 1.62 (116, 505, 506)
7	02463900	1	Pressure Flange (116, 505, 506)
8	01123800	2	Washer, Friction (116, 505, 506)
9	02492300	1	Lever, Deflector (116, 505, 506)
10	08337000	1	Spring-Tension .05 x .44 x 38 x 1.45
11	07533500	1	Knob, Ball-Black 1-.41, .38-16 (116, 505, 506)
12	06437300	2	Washer-Flat-Steel .28 x .62 x .065 (117, 300, 507, 508)
	06437300	3	Washer-Flat-Steel .28 x .62 x .065 (116, 505, 506)
13	06707400	2	Pin-Cotter .09 x .50 (117, 300, 507, 508)
	06707400	3	Pin-Cotter .09 x .50 (116, 505, 506)
14	06947500	1	Cable, Auger
15	06947400	1	Cable, Traction
16	02485551	1	Lever, Clutch
17	05802600	1	Pin-Roll .16 x .88
18	06530200	1	Nut-Locking-Nylon .31-18
19	01054200	1	Spacer, Adapter
20	02422700	1	Adapter
21	05947000	1	Bolt-Hex .31-18 x .75 Grade 5
22	02422800	1	Yoke, Clutch Engagement
23	06529800	3	Nut-Locking-Center .31-18
24	02408600	1	Spacer 1.00 x .64 x .38
25	06005500	1	Screw-Set .31-18 x .38 Socket Head
26	02213500	1	Rod Adapter
27	52404700	1	Spring Assembly
28	06707400	1	Pin-Cotter .09 x .50
29	06707000	2	Pin-Cotter .09 x 1.00
30	02406900	1	Rod, Fork Pivot
31	08309400	1	Spring-Tension .08 x .73 x 3.06 Weldment
32	02427200	1	Clutch Fork

# CHUTE, AUGER AND BATTERY

Model 924116, 117, 300, 505, 506, 508

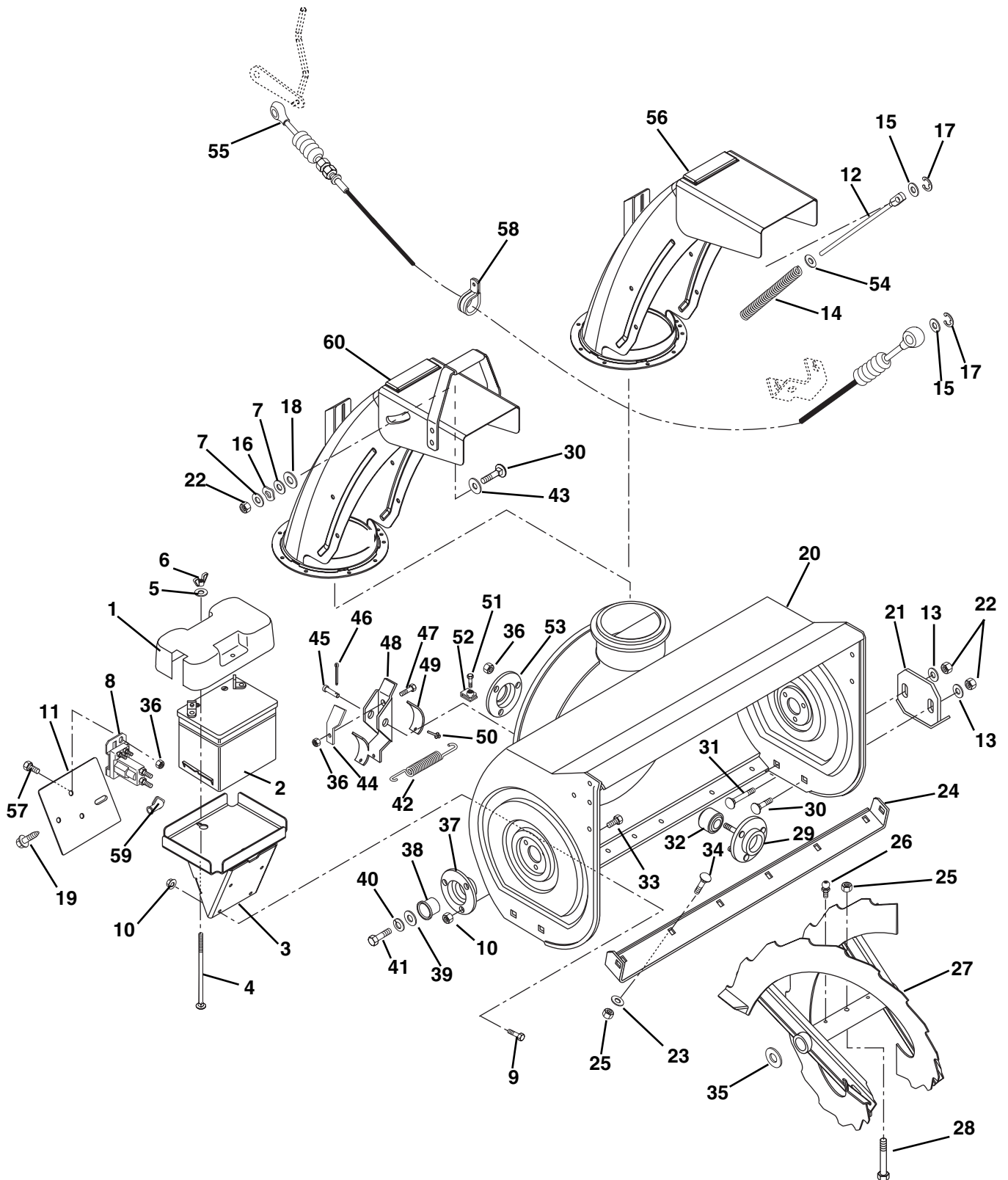

PS0437

# CHUTE, AUGER AND BATTERY

Model 924116, 117, 300, 505, 506, 508

Item	Part No.	Qty.	Description
1	04912900	1	Cover, Battery (300, 505, 506, 508)
2		A/R	Battery Recommend 340 to 350 CCA at 0° F. Size U1R or U1L (300, 505, 506, 508)
3	02484559	1	Battery Tray (506)
	02488659	1	Battery Tray (300, 508, 505)
4	06220400	2	Bolt-Round Head Square Neck .25-20 x 7.00 (300, 505, 506, 508)
5	06437300	6	Washer-Flat-Steel .28 x .62 x .065 (300, 505, 506, 508)
6	06537500	2	Wing Nut-Locking .25-20 (300, 505, 506, 508)
7	06436200	2	Washer-Flat-Steel .41 x .81 x .065 (300, 505, 506, 508)
8	03679000	1	Solenoid (300, 505, 506, 508)
9	05946800	4	Bolt-Hex .25-20 x .75 Grade 5 (300, 505, 506, 508)
10	06530100	10	Nut-Lock-Flange .25-20
11	02484459	1	Cover, Solenoid (300, 505, 506, 508)
12	02479800	1	Rod, Chute (116, 505, 506)
13	06435900	4	Washer-Flat-Steel .44 x 1.00 x .083
14	08335200	1	Spring, Compression (116, 505, 506)
15	06437300	2	Washer-Flat-Steel .28 x .62 x .065 (116, 505, 506)
16	01320200	1	Wave Washer (117, 300, 508)
17	05718500	2	Ring, Retaining-External .22 x .035 (116, 505, 506)
18	06416800	1	Washer-Plastic .39 x .88 x .062 (117, 300, 508)
19	07412000	2	Screw-Tapping .25-20 x .50 Hex Washer Head (300, 505, 506, 508)
20	52414200	1	Blower Housing w/Decal 28" (116)
	52414300	1	Blower Housing w/Decal 24" (117)
	52414400	1	Blower Housing w/Decal 24" (300)
	52414500	1	Blower Housing w/Decal 28" (508)
	52414600	1	Blower Housing w/Decal 32" (505)
	52414700	1	Blower Housing w/Decal 36" (506)
21	02483059	2	Runner, Skid Shoe-1/2" Flange (117, 300, 508, 505, 506)
	02483859	2	Runner, Double Flange (116)
22	06529600	4	Nut-Locking .38-16 (116, 505, 506)
	06529600	5	Nut-Locking .38-16 (117, 300, 508)
23	06435700	5	Washer-Flat-Steel .38 x .88 x .083 (116, 117, 300, 508)
	06435700	7	Washer-Flat-Steel .38 x .88 x .083 (505)
	06435700	6	Washer-Flat-Steel .38 x .88 x .083 (506)
24	02479159	1	Scraper Blade 28" (116)
	01016459	1	Scraper Blade 24" (117, 300)
	00620159	1	Scraper Blade 28" (508)
	00620859	1	Scraper Blade 32" (505)
	03519259	1	Scraper Blade 36" (506)
25	06529800	7	Nut-Locking-Center .31-18 (116, 117, 300, 508)
	06529800	9	Nut-Locking-Center .31-18 (505)
	06529800	8	Nut-Locking-Center .31-18 (506)
26	07012600	4	Fitting-Lube .25-28 x .256
27	52410700	1	Rake, Left Hand - 28" (16" O.D.) (508) (Includes Item 26)
	52410800	1	Rake, Right Hand - 28" (16" O.D.) (508) (Includes Item 26)
	52413600	1	Rake, Right Hand - 24" (16" O.D.) (117, 300) (Includes Item 26)
	52413500	1	Rake, Left Hand - 24" (16" O.D.) (117, 300) (Includes Item 26)
	52411800	1	Rake, Left Hand - 28" (15" O.D.) (116) (Includes Item 26)
	52411900	1	Rake, Right Hand - 28" (15" O.D.) (116) (Includes Item 26)
	52412200	1	Rake, Left Hand - 32" (16" O.D.) (505) (Includes Item 26)
	52412300	1	Rake, Right Hand - 32" (16" O.D.) (505) (Includes Item 26)
	52412500	1	Rake, Left Hand - 36" (16" O.D.) (506) (Includes Item 26)
	52412600	1	Rake, Right Hand - 36" (16" O.D.) (506) (Includes Item 26)

# AUGER AND BATTERY

---

## Model 924116, 117, 300, 505, 506, 508

Item	Part No.	Qty.	Description
28	51001500	2	Shear Bolt Service Assembly (Includes Item 25)
29	00301700	1	Bearing Flange (116,117, 300, 508, 505)
	03086200	1	Bearing Flange (506)
30	06211800	2	Bolt-Round Head Square Neck .38-16 x .75 (116, 505, 506)
	06211800	3	Bolt-Round Head Square Neck .38-16 x .75 (117, 300, 508)
31	06212000	3	Bolt-Round Head Square Neck .38-16 x 1.00
32	05418200	1	Bearing-Ball 1.0 x 2.0 x .56 (506)
	05406300	1	Bearing-Ball .75 x 1.75 x .50 (116, 117, 300, 505, 508)
33	07028600	6	Bolt-Serrated-Neck-Slotted .25-20 x .50
34	06212200	5	Bolt-Round Head Square Neck .312-18 x .62 (116, 117, 300, 505, 508)
	06212200	7	Bolt-Round Head Square Neck .312-18 x .62 (505)
	06212200	6	Bolt-Round Head Square Neck .312-18 x .62 (506)
35	06436300	2	Washer-Flat Steel 1.01 x 1.51 x .062
36	06529700	6	Nut-Locking-Center .25-20
37	02437451	2	Bearing Support
38	05503500	2	Bushing-Flange 1.00 x 1.12 x .62 x 1.50
39	06436400	2	Washer-Flat-Steel .51 x 1.44 x .13
40	06306600	2	Washer-Lock .50 x .151
41	05947100	2	Bolt-Hex .50-13 x 1.00 Grade 5
42	08316400	1	Spring-Tension .06 x .56 x 8.00
43	06441100	1	Washer-Flat-Steel .52 x .83 x .062 (117, 300, 508)
44	02440551	1	Arm Extension (116)
45	02448100	1	Clevis Pin
46	06707500	1	Pin-Cotter .06 x .75
47	05946800	1	Bolt-Hex .25-20 x .75 (116)
48	52404800	1	Brake Arm Assembly (Contains Items 49, 50)
49	02217800	1	Brake Lining
50	06806700	2	Rivet-Tubular .19 x .44
51	07028500	2	Bolt-Hex Flanged Whizloc Head .38-16 x .75
52	07002600	2	Nut-Retainer .38-16
53	01014200	1	Bearing Flange (116, 117, 300, 505, 508)
	03086100	1	Bearing Flange (506)
54	06437200	1	Washer-Flat-Steel .34 x .69 x .065 (116, 505, 506)
55	06945400	1	Cable, Control (116, 505, 506)
56	52411000	1	Chute, Discharge with Remote (116)
	52414800	1	Chute- Electric (505, 506)
57	05947900	2	Bolt-Hex .25-20 x .50 Grade 5
58	06908200	1	Clamp-Cushioned (116, 505, 506)
59	07533200	2	Boot, Eyelet Terminal (300, 505, 506, 508)
60	52410900	1	Chute, Discharge without Remote (117, 300, 508)
61	06308400	2	Washer-Locking .25 x.06 Regular

# GEAR CASE-ALUMINUM

Model 924116

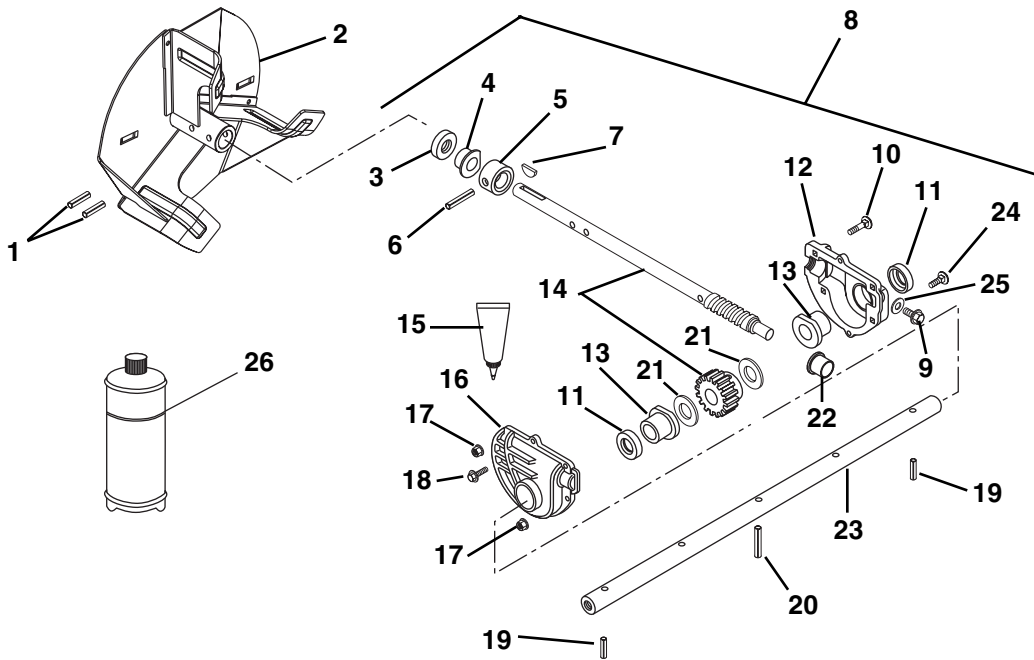

PS0692

Item	Part No.	Qty.	Description
1	05803700	2	Pin-Roll .25 x 1.75
2	02477251	1	Impeller-.75 I.D.x 12" O.D.
3	05618900	1	Seal, Oil .75 x 1.38 x .31
4	05511200	1	Bushing-Flange .75 x 1.00 x .75 x 1.25
5	03210300	1	Thrust Collar
6	05804500	1	Pin-Groove .19 x 1.25
7	06600100	1	Key-Woodruff .19 x .88 x .38
8	52413400	AR	Case, Gear-Large Bore-28" (Contains Items 3-6, 9-18, 20-25)
9	07412900	1	Screw-Tapping .38-16 x .50
10	06219700	2	Bolt-Round Head Square Neck .25-20 x 1.25 Grade 5
11	05618800	2	Seal 1.00 x 1.38
12	02470600	1	LS Case Half Left Hand Large Bore
13	05530100	2	Bushing-Flanged 1.00 x 1.12 x 1.50 x .50
14	52402600	1	Worm Shaft and Gear Assembly
15	00925700	1	Loctite Gasket 518 850 cc Cartridge
16	02470700	1	LS Case Half Right Hand Large Bore
17	06530100	4	Nut-Locking-Flange .25-20
18	07413000	2	Screw-Tapping 10-24 x .75
19	05803000	2	Pin-Roll .19 x 1.50
20	05806900	1	Pin-Groove .31 x 1.44
21	06416600	2	Washer-Flat-Steel 1.01 x 1.54 x .062
22	05520600	1	Bushing-Flange .50 x 1 x .75
23	02479300	1	Rake Shaft 28"
24	06219800	2	Bolt-Round Head Square Neck .25-20 x 1.00
25	06442500	1	Washer-Fiber .44 x .66 x .032
26	00008000	1	Ariens 16 Oz. Bottle of L2 Lube (2 oz. capacity)

# GEAR CASE-CAST IRON

Model 924117, 300, 505, 506, 508

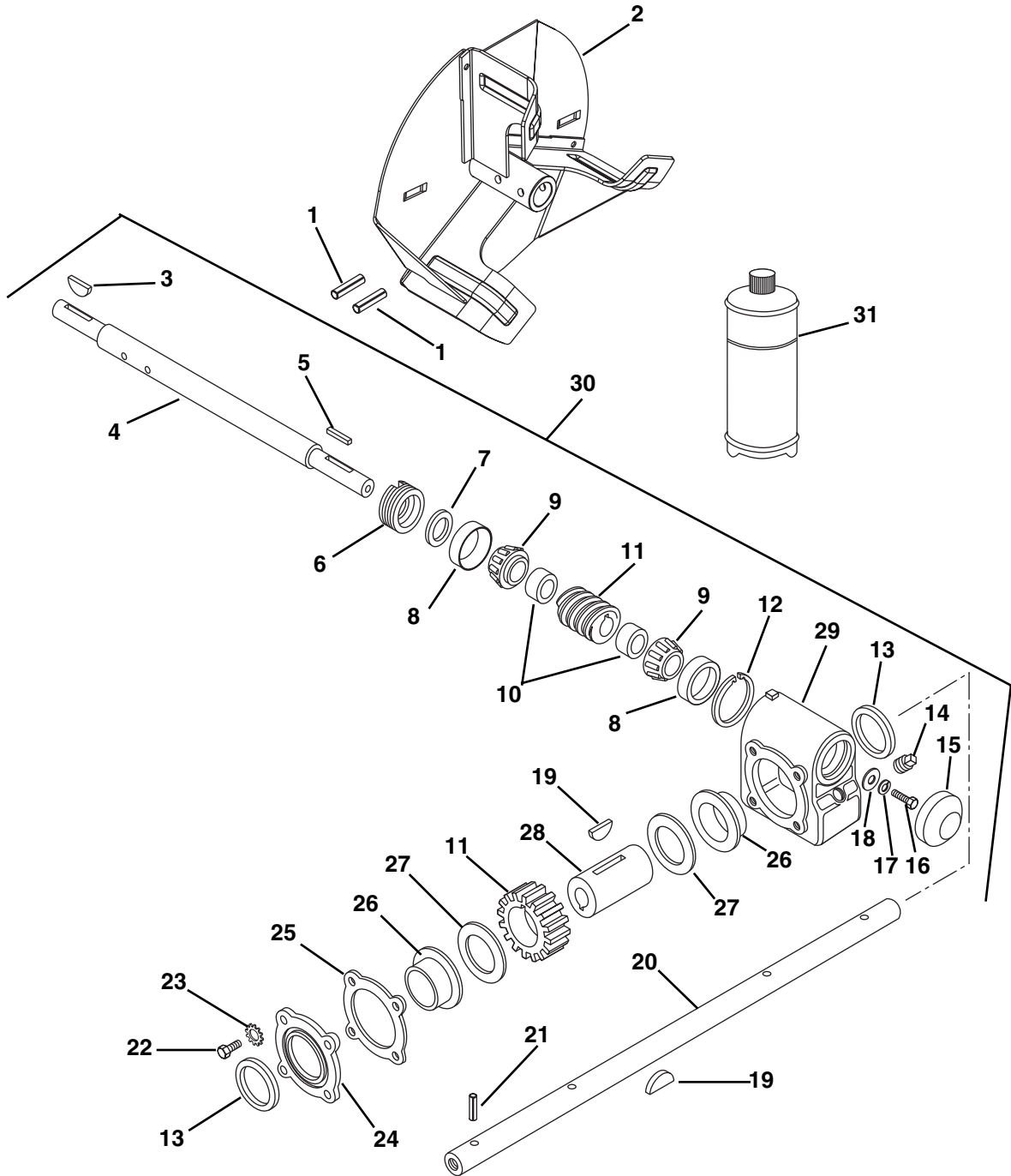

PS0472

# GEAR CASE-CAST IRON

Model 924117, 300, 505, 506, 508

Item	Part No.	Qty.	Description
1	05801500	2	Pin-Roll .31 x 1.75
2	02476951	1	Impeller -1.00 I.D. x 14" O.D. (506)
	00643151	1	Impeller -1.00 I.D. x 12" O.D. (117, 300, 508, 505)
3	06600100	1	Key-Woodruff .19 x .88 x .38
4	02437500	1	Worm Shaft-1.00" Diameter (506)
	02406200	1	Worm Shaft-1.00" Diameter (117, 300, 508, 505)
5	06601300	1	Key-Square .19 x 1.00 x .19
6	02401500	1	Adjustment Plug
7	05606100	1	Seal 1.00 x 1.31 x .15
8	05404400	2	Bearing-Cup 1.78 x .48
9	05404500	2	Bearing-Cone .75 x .61
10	00200500	2	Bearing Spacer 1.12 x 1.52 x .5
11	52400900	1	Worm and Gear Service Assembly
12	05707500	1	Ring-Retaining-Internal 1.78 x .062
13	05607000	2	Seal 1.63 x 2.13 x .25
14	00113800	1	Pipe Plug
15	00403700	1	Dust Cap
16	05947000	1	Bolt-Hex .31-18 x .75 Grade 5
17	06307400	1	Washer-Lock .31 x .10
18	06437500	1	Washer-Flat-Steel .33 x 1.00 x .09
19	06600800	2	Key-Woodruff .25 x .88 x .38
20	02472100	1	Rake Shaft 24" 1.00 Diameter (117, 300)
	02459600	1	Rake Shaft 28" 1.00 Diameter (508)
	02406500	1	Rake Shaft 32" 1.00 Diameter (505)
	03519500	1	Rake Shaft 36" 1.00 Diameter (506)
21	05803000	2	Pin-Roll .19 x 1.50
22	05946800	4	Bolt-Hex .25-20 x .75 Grade 5
23	06306800	4	Washer-Lock-External .26 x .50 x .026
24	02401300	1	Gear Case Cover
25	00200800	1	Gasket
26	05505900	2	Bushing-Flange 1.63 x 1.87 x 1.68 x 2.25
27	06408700	2	Washer-Flat-Steel 1.63 x 2.50 x .01
28	02406400	1	Gear Case Shaft
29	02400200	1	Gear Case- Cast Iron
30	52408000	AR	Gear Case- Cast Iron (117, 300, 505, 508)
	52403500	AR	Gear Case, 32"- Cast Iron (506)
31	00008000	1	Ariens 16 oz. Bottle of L2 Lube (5 oz. capacity)

# DISCHARGE CHUTE CRANK

Model 924116, 117, 300, 508

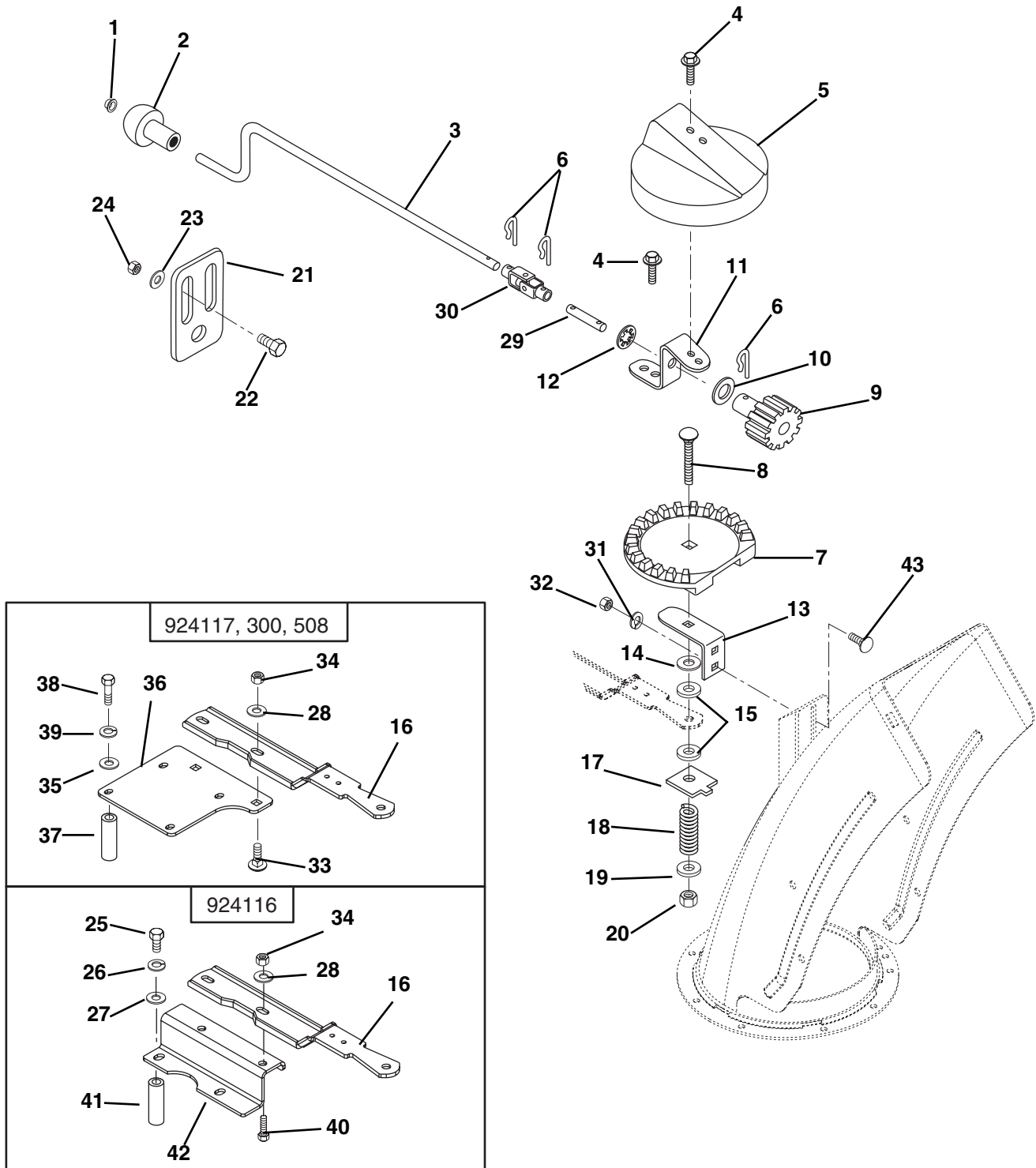



# DISCHARGE CHUTE CRANK

Model 924116, 117, 300, 508

Item	Part No.	Qty.	Description
1	01019800	1	Cap, .38 Rod
2	07508300	1	Knob
3	02480600	1	Crank, Chute
4	07412000	4	Screw .25-20 x .50 Hex Washer Head Self Tapping
5	03223000	1	Cover, Gear
6	06714500	3	Pin-Spring Clip
7	03222900	1	Gear, Chute
8	06224400	1	Bolt-Round Head Square Neck .38-16 x 2.50 Grade 5
9	53204400	1	Pinion Gear w/Bracket (Contains Items 10-12)
10	06436100	1	Washer-Flat-Steel .63 x 1.01 x .062
11	03220551	1	Bracket, Gear
12	03224300	1	Push Nut
13	03220751	1	Gear Strap
14	06439300	1	Washer-Flat-Steel .38 x 1.50 x .062
15	01123800	2	Friction Washer
16	02480351	1	Bracket, Chute Support
17	03219000	1	Friction Plate
18	08320900	1	Spring-Compression .19 x .56 x 1.62
19	06436200	1	Washer-Flat-Steel .41 x .81 x .065
20	06529600	1	Nut-Locking-Center .38-16
21	02492451	1	Bracket, Chute Crank Support
22	05947900	2	Bolt-Hex .25-20 x .50 Grade 5
23	06435800	2	Washer-Flat-Steel .31 x .73 x .065
24	06529700	2	Nut-Locking-Center .25-20
25	05947500	2	Bolt-Hex .31-18 x 1.25 Grade 5 (116)
26	06307400	2	Washer-Locking .31 x .08 Regular (116)
27	06437200	2	Washer-Flat-Steel .34 x .69 x .065 (116)
28	06435800	2	Washer-Flat-Steel .31 x .73 x .065
29	02479700	1	Pin, Connector
30	02470400	1	Universal Joint
31	06308400	1	Washer-Locking .25 x .062
32	06533200	1	Nut-Hex .25-20
33	06215700	2	Bolt-Round Head Square Neck .31-18 x .75
34	06529800	2	Nut-Locking-Center .31-18
35	06437300	4	Washer-Flat-Steel .28 x .62 x .065 (117, 300, 508)
36	02480751	1	Bracket, Engine (117, 300, 508)
37	02480900	4	Spacer, Tube (117, 300, 508)
38	05946800	4	Bolt-Hex .25-20 x .75 Grade 5 (117, 300, 508)
39	06308400	4	Washer-Locking .25 x .06 x .065 (117, 300, 508)
40	05947000	2	Bolt-Hex .31-18 x .75 Grade 5 (116)
41	03233600	2	Spacer, Tube (116)
42	02480251	1	Bracket, Engine (116)
43	06219900	1	Bolt-Round Head Square Neck .25-20 x .75 Grade 5

# ELECTRIC DISCHARGE CHUTE

Model 924505, 506

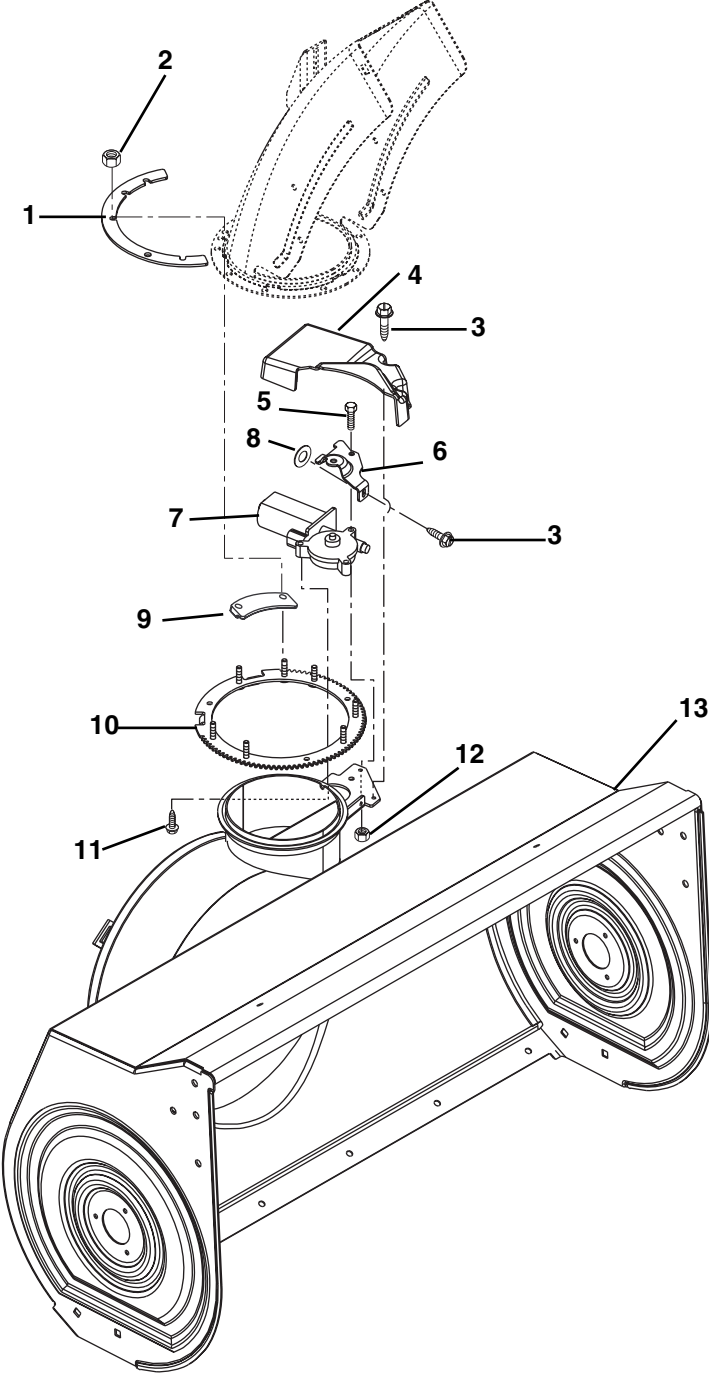

# ELECTRIC DISCHARGE CHUTE

---

Model 924505, 506

Item	Part No.	Qty.	Description
1	02486959	2	Ring, Cover
2	06530100	6	Nut-Locking-Flange .25-20
3	07411900	3	Screw-Tapping 12-24 x .50 Hex Washer Head
4	02487100	1	Cover, Motor
5	05947400	1	Bolt-Hex .25-20 x 1.25 Grade 5
6	02488251	1	Bracket, Electric Motor
7	52416500	1	Motor, Electric Right Hand- Chute
8	06437300	1	Washer-Flat-Steel .28 x .62 x .065
9	02487000	3	Clamp, Chute
10	02486800	1	Gear, Chute
11	07414400	2	Screw-Tapping .31-18 x.75 Hex Washer Head
12	06529700	1	Nut-Locking-Center .25-20
13	02485159	1	Housing, Blower-32" E

# BRUSH HEAD

Model 924507

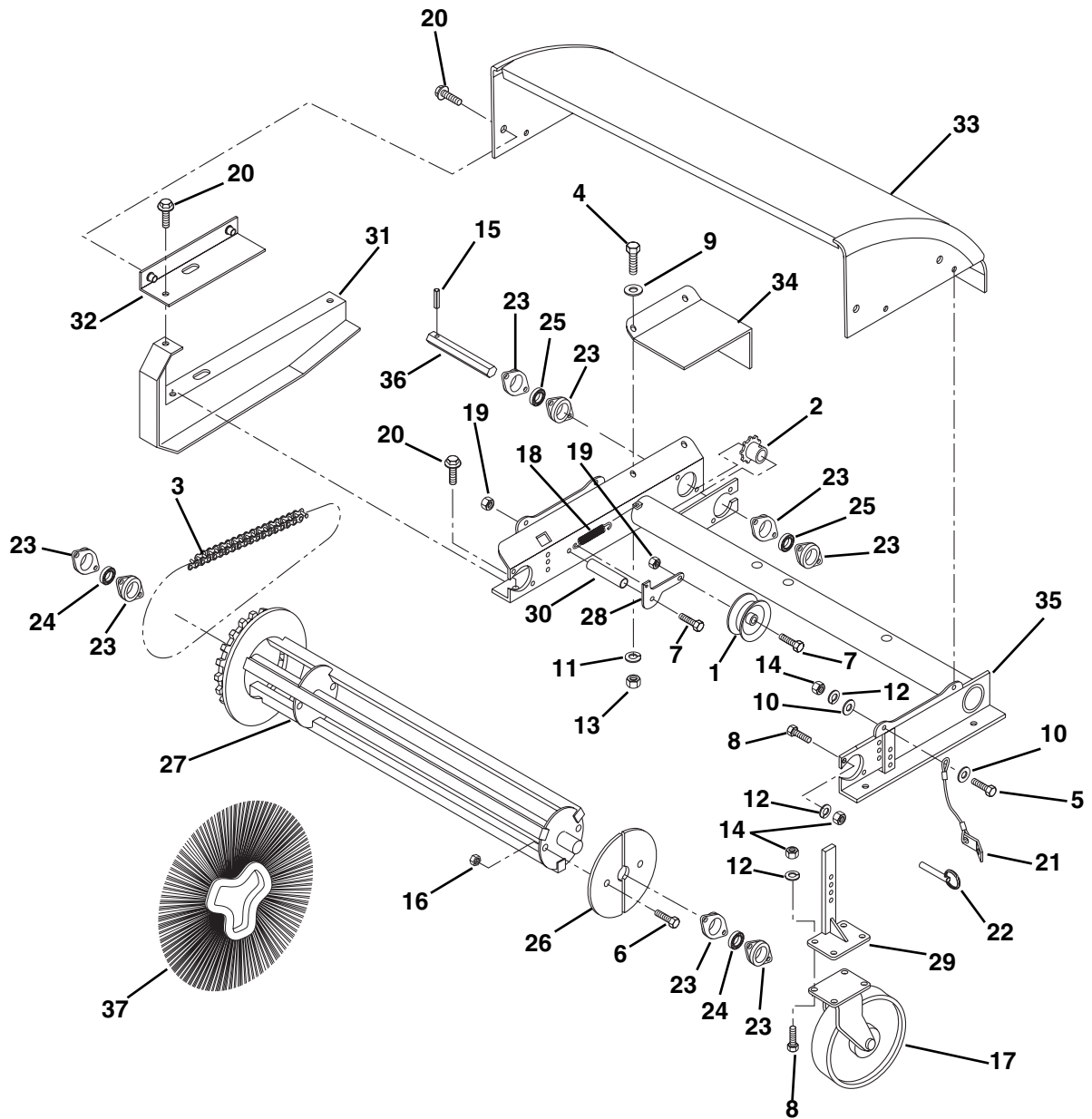

PS0592

# BRUSH HEAD

Model 924507

Item	Part No.	Qty.	Description
1	01061300	1	Chain Tightener
2	01060900	1	Sprocket
3	02468300	1	Chain, Assembly #40 x 106
4	05946800	2	Bolt-Hex .25-20 x .75 Grade 5
5	05946900	4	Bolt-Hex .31-18 x 1.00 Grade 5
6	05963700	2	Bolt-Hex .31-18 x 2.25 Grade 5
7	05957900	2	Bolt-Hex .38-16 x 1.50 Grade 5
8	05947000	16	Bolt-Hex .31-18 x .75 Grade 5
9	06437300	2	Washer-Flat-Steel .28 x .62 x .065
10	06435800	8	Washer-Flat-Steel .31 x .73 x .065
11	06308400	2	Washer-Lock .25 x .062 Regular
12	06308600	20	Washer-Lock .31 x .078 Regular
13	06533200	2	Nut-Hex .25-20
14	06529200	20	Nut-Hex .31-18
15	02468400	1	Pin, Spring Lok .19 x 1.25
16	02468500	2	Nut, Lok Stamped .31-18
17	07109400	2	Wheel, 5 inch Diameter
18	02468600	1	Spring, Tension .50 x 3.00
19	06529600	2	Nut-Locking-Center .38-16
20	02468700	5	Screw, Gear 10.9 M6 x 1-20
21	02468800	2	Lanyard .06 Cable 1.25 x 6
22	00547800	2	Pin, Hitch .38 x 2
23	02411300	8	Flange, Spherical 2 inch
24	05423400	2	Bearing 1.00 Bore, Spherical
25	05409700	2	Bearing-Ball .84 Hex x 52 MM x 1.07
26	01062900	1	Retainer Plate
27	02469000	1	Weldment, Core
28	02469100	1	Arm, Idler
29	02469200	2	Weldment, Caster Leg
30	02469300	1	Bushing .62 x 12 Gauge x .75
31	02469400	1	Shield, Chain
32	02469500	1	Shield Chain Top
33	02469600	1	Weldment, Head
34	02469700	1	Shield, Input
35	02469800	1	Weldment, Broom Frame
36	02469900	1	Shaft, Hex 20.5 with Hole
37	02470000	1	Set, 24 Section

# BRUSH DRIVE UNIT

Model 924507

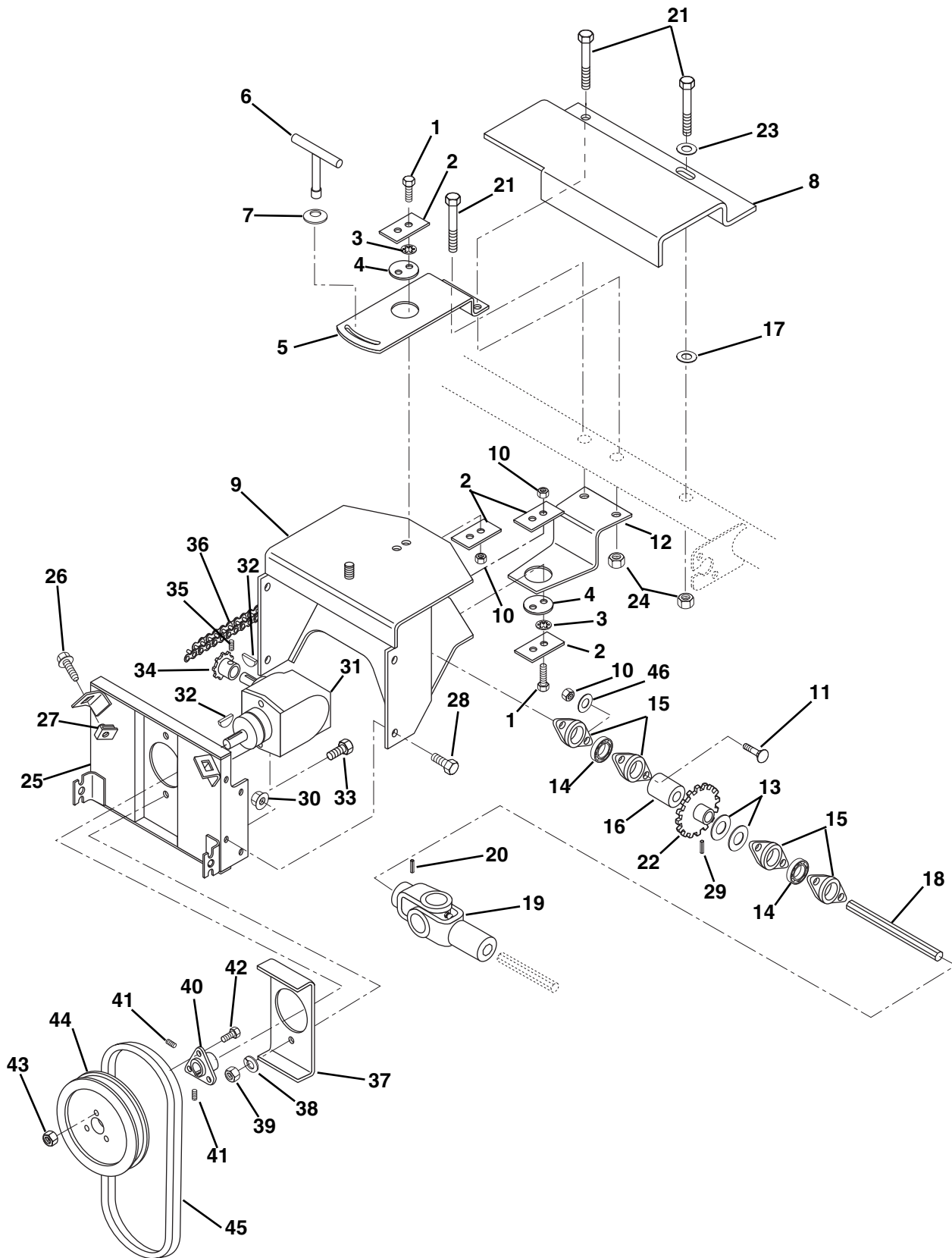

PS0581

# BRUSH DRIVE UNIT

Model 924507

Item	Part No.	Qty.	Description
1	05947500	4	Bolt-Hex .31-18 x 1.25 Grade 5
2	02404800	4	Retainer
3	06307200	4	Washer-Locking-Internal .313 x .030
4	02404900	2	Pivot, Center
5	02471751	1	Plate, Top Mount
6	02470900	1	T-Lock Handle
7	00597000	1	Washer-Cupped Serrated .38
8	02470151	1	Guard, Shaft
9	02405051	1	Frame, Adapter
10	06529800	4	Nut-Locking-Top .31-18
11	06215700	4	Bolt-Round Head Square Neck .31-18 x .75 Grade 5
12	02471851	1	Plate, Bottom Mount
13	06418500	2	Washer-Flat-Steel 1.02 x 1.50 x .125
14	05409700	2	Bearing, Ball
15	02429600	4	Flange, Bearing
16	02447600	1	Spacer 1.01 x 1.31 x .50
17	06436800	1	Washer-Flat-Steel .39 x .88 x .18
18	02429100	1	Shaft
19	02495500	1	Joint, Universal
20	05803000	1	Pin-Roll .19 x 1.50
21	05961100	3	Bolt-Hex .38-16 x 3.25 Grade 5
22	01062000	1	Sprocket
23	06436200	1	Washer-Flat-Steel .41 x .81 x .065
24	06529600	3	Nut-Locking-Center .38-16
25	02429451	1	Plate, Mounting
26	07028500	2	Bolt, Hex Flanged Whizloc Head .38-16 x .75
27	07002600	2	Nut-Retainer .38-16
28	05959400	4	Bolt-Hex .38-16 x .75 Grade 5
29	05805600	1	Pin-Roll .19 x 1.75
30	06529600	4	Nut-Locking-Center .38-16
31	02400400	1	Gear Box Assembly
32	06600300	2	Key-Woodruff .19 x .75 x .31 SAE 9
33	05958000	2	Bolt-Hex .38-16 x 1.25 Grade 5
34	02429800	1	Sprocket
35	06001100	2	Screw-Set .25-20 x .25 Socket Head Cup Point
36	01207800	1	Chain
37	02429551	1	Plate, Stiffener
38	06308800	2	Washer-Lock .38 x .094
39	06529400	2	Nut-Hex .38-16
40	50202100	1	Hub Assembly
41	06005500	2	Screw-Set .31-18 x .38 Socket Head Cup Point
42	07005300	3	Bolt-Serrated Round Head Slotted .31-18 x .75
43	06530400	3	Nut-Locking-Flanged .31-18
44	07307000	1	Pulley-V 9.00 x 1.25
45	07210800	1	V-Belt
46	06435700	4	Washer-Flat-Steel .38 x .88 x .083

# ELECTRICAL

Model 924116, 117, 300, 505, 506, 507, 508

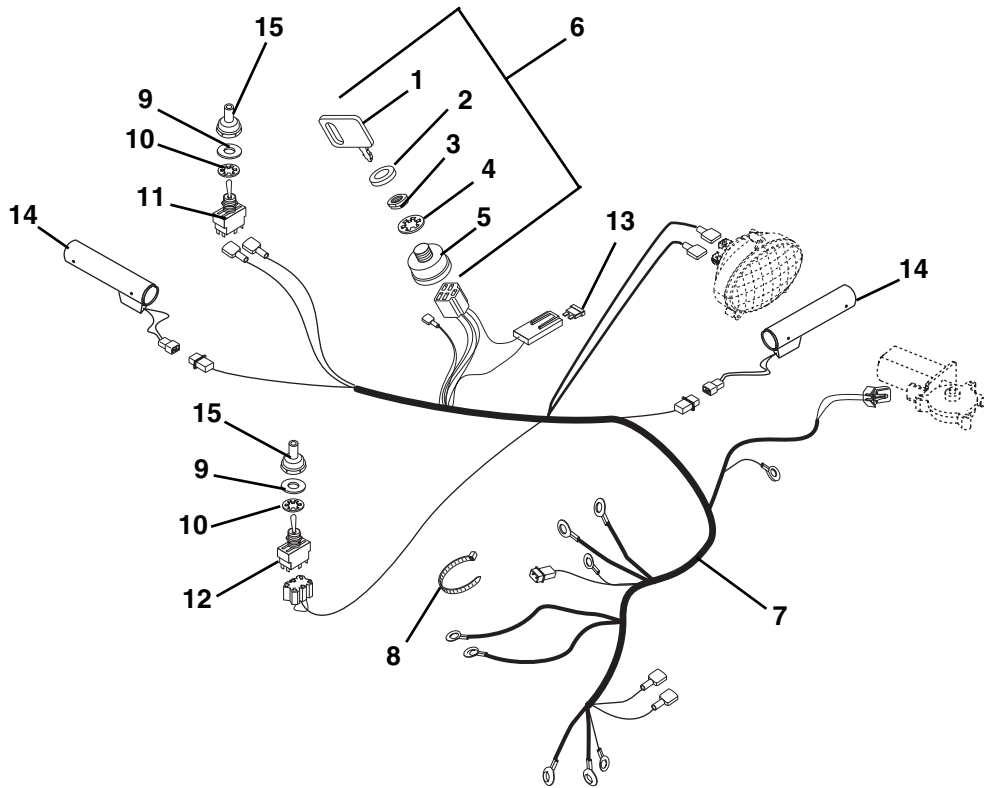

PS0891

tem	Part No.	Qty.	Description
1	02460700	1	Key- with Cap (300, 505, 506, 508)
2	07517700	1	Cap- Ignition Switch (300, 505, 506, 508)
3	06517300	1	Nut-Panel .63-32 (300, 505, 506, 508)
4	06306900	1	Washer-Locking-Internal .63 x .045 (300, 505, 506, 508)
5	02739600	1	Ignition Switch Assembly (300, 505, 506, 508)
6	52709300	1	Switch Assembly (Includes Items 1 thru 5) (300, 505, 506, 508)
7	02494400	1	Harness, Wiring-Light and Hand Warmer (116, 117, 507)
	02494300	1	Harness, Wiring-Light and Hand Warmer 12V (300, 508)
	02494200	1	Harness, Wiring-Light and Hand Warmer Chute (505, 506)
8	07517300	3	Cable Tie (300, 505, 506, 508)
	07517300	1	Cable Tie (116, 117, 507)
9	06403800	2	Washer-Flat-Steel .51 x .88 x .024 (505, 506)
	06403800	1	Washer-Flat-Steel .51 x .88 x .024 (116, 117, 300, 507, 508)
10	06310900	2	Washer-Locking-Internal .56 x .04 (505, 506)
	06310900	1	Washer-Locking-Internal .56 x .04 (116, 117, 300, 507, 508)
11	02485700	1	Switch, On/Off Hand Warmer
12	02485600	1	Switch, Chute Rotation (505, 506)
13	00524700	1	15 AMP Fuse
14	07532900	2	Hand Warmer with Terminal (Recommend Fast Drying Epoxy for Installation)
15	09207600	AR	Boot, Switch (Optional)



# CONTINUITY DIAGRAM

**Model 924300, 505, 506, 508**

The diagrams below show the various states of connection for electrical components.  
The solid lines on switches show continuity.

**NOTE:** All switches are viewed from the rear.

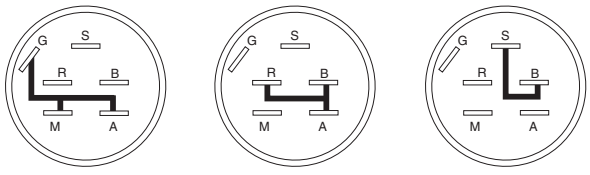
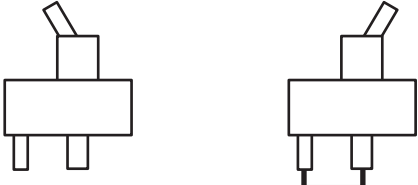
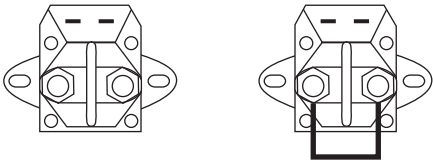
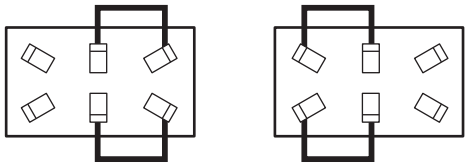
<p><b>Key Switch</b> (02739600)</p>  <div style="display: flex; justify-content: space-around; margin-top: 10px;"> <span>OFF</span> <span>RUN</span> <span>START</span> </div>	<p><b>Hand Warmer Switch</b> (02485700)</p>  <div style="display: flex; justify-content: space-around; margin-top: 10px;"> <span>HAND WARMER OFF</span> <span>HAND WARMER ON</span> </div>
<p><b>Solenoid (Top View)</b> (03679000)</p>  <div style="display: flex; justify-content: space-around; margin-top: 10px;"> <span>NOT ENERGIZED</span> <span>ENERGIZED</span> </div>	<p><b>Chute Motor Switch (Models 505, 506)</b> (02485600)</p>  <div style="display: flex; justify-content: space-around; margin-top: 10px;"> <span>LEVER LEFT CHUTE LEFT</span> <span>LEVER RIGHT CHUTE RIGHT</span> </div>

# CONTINUITY AND WIRING DIAGRAMS

Model 924116, 117, 507

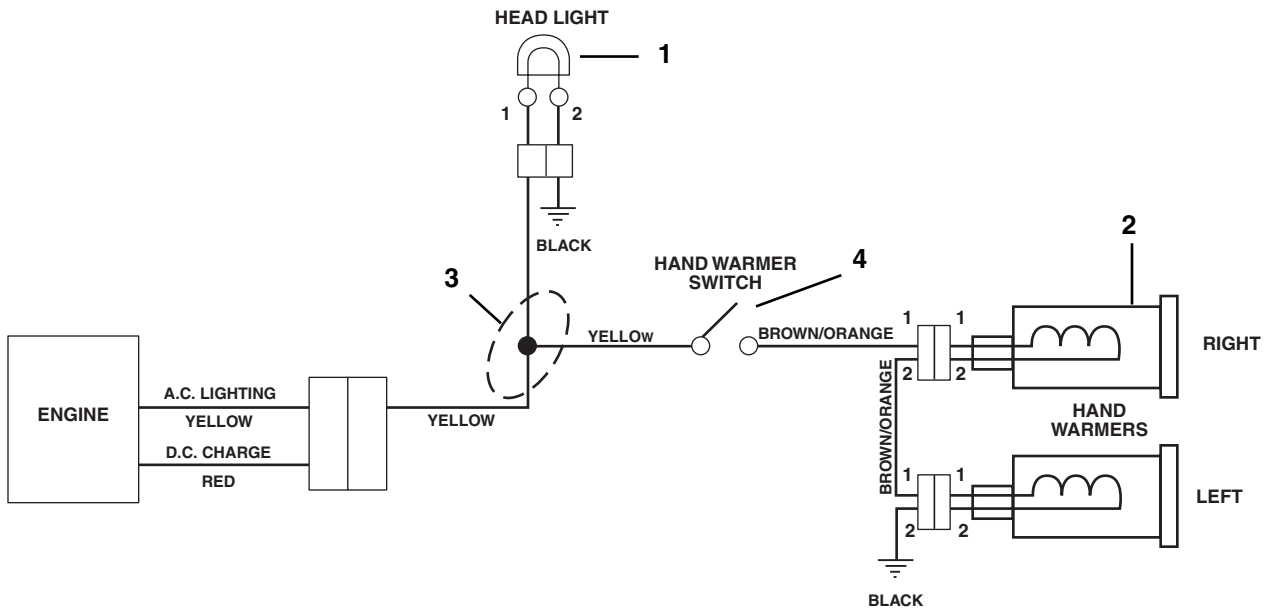

PS0830

Item	Part No.	Qty.	Description
1	02485000	1	Headlamp, Oval with 1156 Bulb
2	07532900	2	Warmer, Hand - with Terminal (Recommend Fast Drying Epoxy for Installation)
3	02488800	1	Wire Harness-Hand Warmers and Light
4	02485700	1	Switch, On/Off Hand Warmer

The diagrams below show the various states of connection for electrical components.

The solid lines on switches show continuity.

**NOTE:** All switches are viewed from the rear.

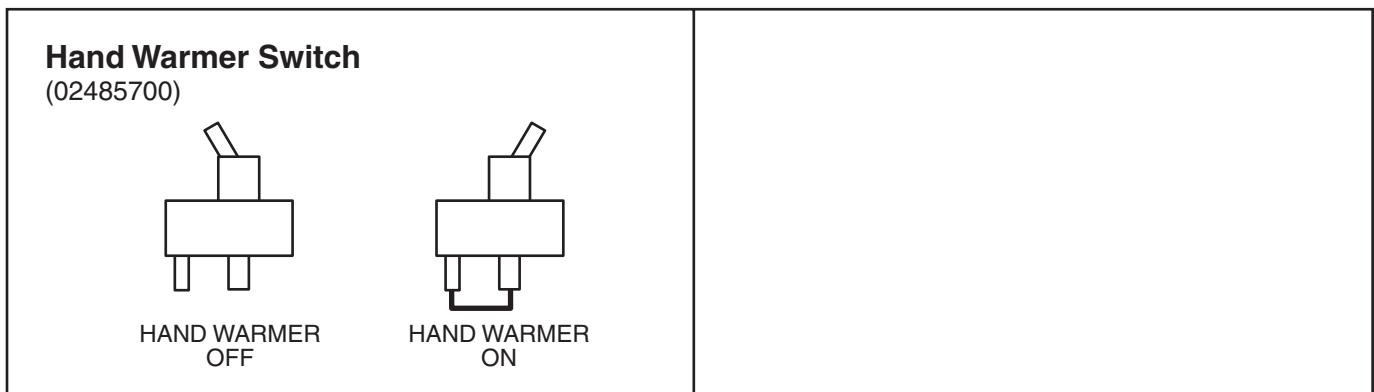

PS0820

# WIRING DIAGRAM

Model 924300, 508

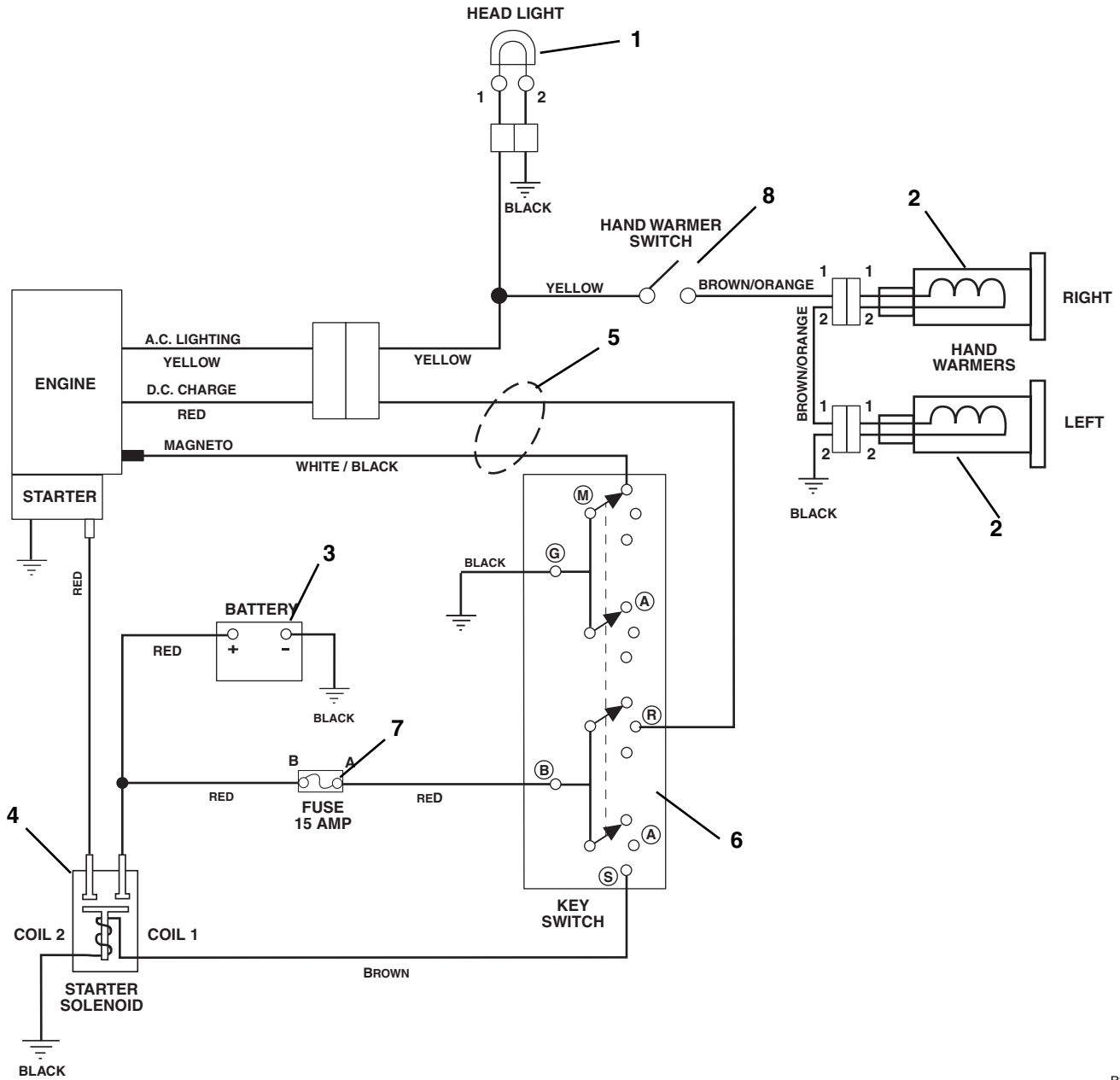

PS0672

Item	Part No.	Qty.	Description
1	02485000	AR	Headlamp, Oval with 1156 Bulb
2	07532900	2	Warmer, Hand - with Terminal (Recommend Fast Drying Epoxy for Installation)
3		AR	Battery Recommend 340 to 350 CCA at 0° F. Size U1R or U1L
4	03679000	1	Solenoid
5	02494300	1	Wire Harness 12 Volt
6	52709300	1	Switch Assembly
7	00524700	1	15 AMP Fuse
8	02485700	1	Switch, On/Off Hand Warmer

# WIRING DIAGRAM

Model 924505, 506

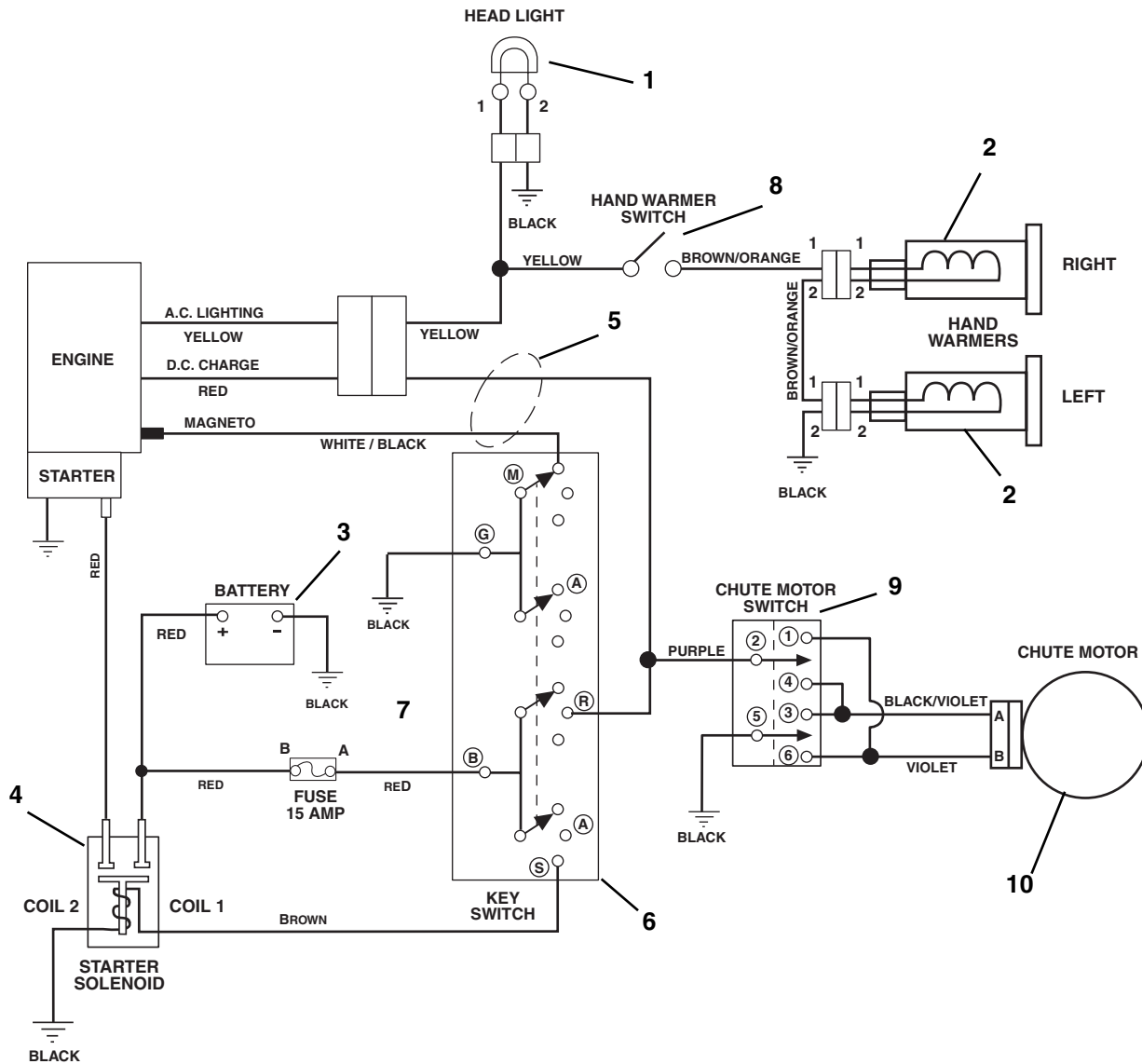

PS0850

Item	Part No.	Qty.	Description
1	02485000	AR	Headlamp, Oval with 1156 Bulb
2	07532900	2	Warmer, Hand - with Terminal Recommend Fast Drying Epoxy for Installation
3		AR	Battery Recommend 340 to 350 CCA at 0° F. Size U1R or U1L
4	03679000	1	Solenoid
5	02488700	1	Wire Harness 12 Volt
6	52709300	1	Switch Assembly
7	00524700	1	15 AMP Fuse
8	02485700	1	Switch, Hand Warmer
9	02485600	1	Switch, Chute Motor
10	52416500	1	Motor, Electric Right Hand- Chute



**Ariens Company**  
655 West Ryan Street  
P.O. Box 157  
Brillion, WI 54110-0157  
920-756-2141  
Fax 920-756-2407  
[www.ariens.com](http://www.ariens.com)