

jWIN

JL-CD808

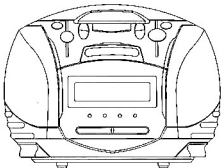

INSTRUCTION MANUAL

LOCATION OF CONTROLS

1. CD Compartment
2. Push Open/Close
3. Standby/On (Alarm Off) Indicator LED
4. Standby/On (Alarm Off) Button
5. Stop Button
6. Play/Pause Button
7. Program Button
8. Sleep Button

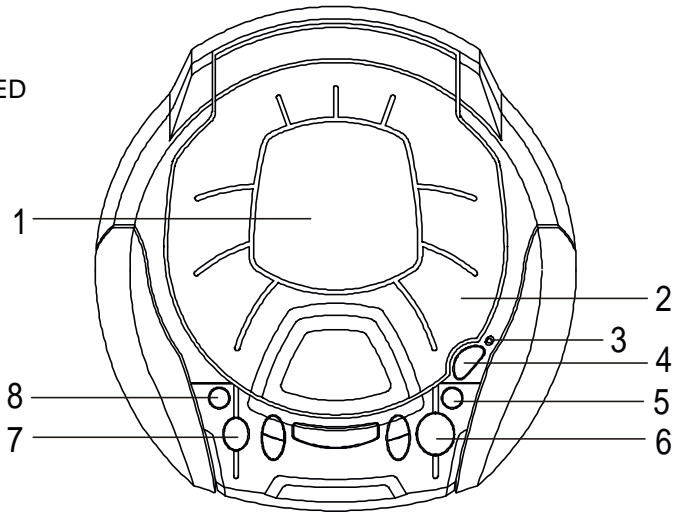

9. Repeat Button
10. CD Display Button
11. Clock Adjust Button
12. Skip Forward / Clock Set (Hour) Button
13. Skip Backward / Clock Set (Minute) Button

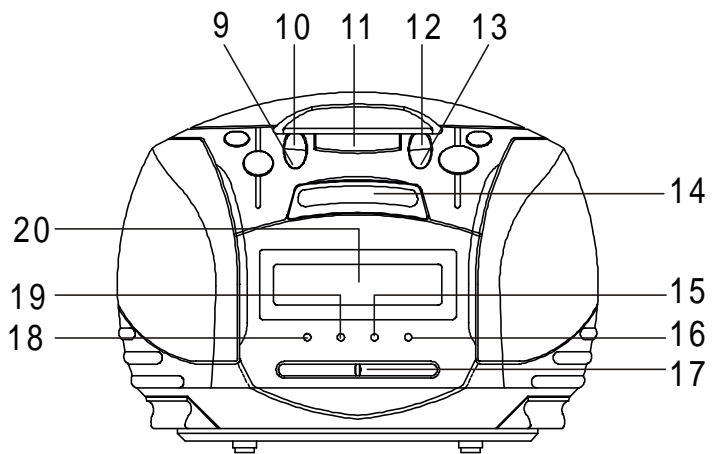

14. Snooze Button
15. Program Indicator
16. FM ST. Indicator
17. Dial Scale & Pointer
18. Sleep Indicator
19. Repeat Indicator
20. LED Display
21. Phones Jack (at the back)
22. AC Cord (at the back)
23. Music / Buzzer Switch
24. Alarm 2 Switch
25. Alarm 1 Switch
26. Tuning Control
27. Volume Control
28. Function Switch (AM/FM CD)
29. FM Antenna (at the back)

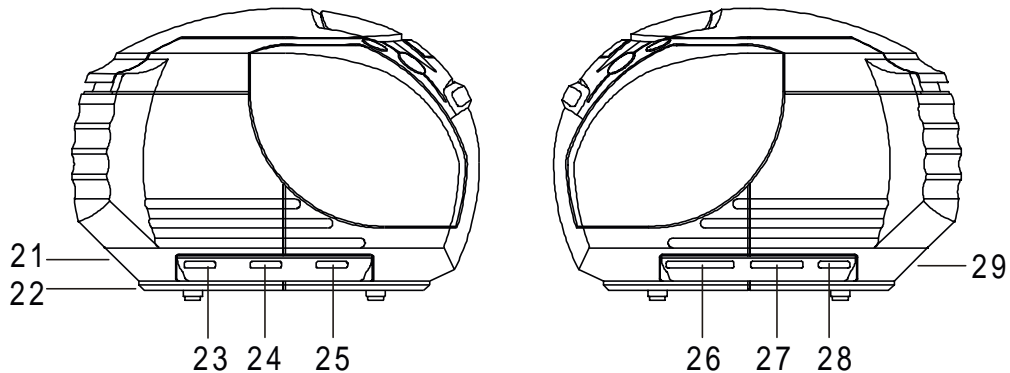

PREPARATION FOR USE

Remove the stereo carefully from the box, retaining the packaging for future use.

Read these instructions carefully before use.

AC POWER OPERATION

Unravel the AC cord and connect it to a conveniently located AC outlet.

Press the STANDBY button to switch the unit on or off.

The Clock Display will show 12:00 and needs to be set.

If the AC cord is disconnected or if there is a power failure, the electronic clock is designed to continue operating internally (without showing the time on the Clock Display) with a 9 volt battery (not included). To install the battery, slide down the compartment cover at the back of unit) to open. Then, connect the battery to the terminals of the battery snap inside the compartment (use of an alkaline battery is recommended) and slide the battery compartment cover back into place.

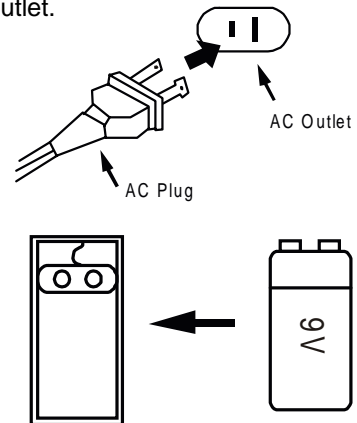

Be sure to check the condition of the battery periodically by disconnecting the AC cord and connecting it again 2 or 3 minutes later. The preset times should continue operating. If the clock resets to "12:00" on the Clock Display, it indicates the battery is dead or not connected properly.

BATTERIES PRECAUTIONS

Follow these precautions when using batteries in this device:

1. Use only the size and type of batteries specified.
2. Be sure to follow the correct polarity when installing the batteries as indicated in the battery compartment. Reversed batteries may cause damage to the device.
3. If the device is not to be used for a long period of time, remove the batteries to prevent injury from possible battery leakage.

LISTENING TO THE RADIO

OPERATION

- Press the STANDBY/ON button to turn the unit on, the STANDBY/ON LED indicator will light.
- Slide the FUNCTION switch to the desired band (AM or FM) and tune a station by turning the TUNING control.
- When a strong FM stereo signal is received while listening to FM, the FM ST indicator will light and the sound will be heard in stereo.
- Adjust the VOLUME control as desired.

ANTENNA

For FM reception there is a built-in one-meter FM aerial wire at the rear of the unit. Unravel the wire and move it around to obtain the best reception. For MW reception the signals are picked up through the built-in ferrite antenna. You may have to move the unit to obtain the best reception.

IMPORTANT

Since movement of the CD mechanism and the sensitive circuitry may cause interference to a radio tuner nearby, switch this unit off while operating other radio devices.

This product utilizes a laser

Danger - Invisible laser radiation when opened and interlock failed or defeated. Avoid direct exposure to the beam.

Caution - Use of controls, adjustments, or procedures not listed in this manual may result in hazardous radiation exposure.

CONCERNING COMPACT DISCS

Only compact discs identified with this mark can be used with this player.



HANDLING COMPACT DISCS

To remove a disc from its storage case, press down on the centre of the case and lift the disc out, holding it carefully by the edges.

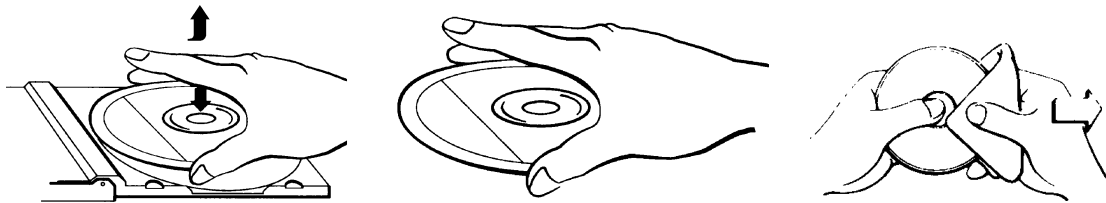

Fingerprints and dust should be carefully wiped off the disc's recorded surface with a soft cloth. Unlike conventional records, compact discs have no grooves to collect dust and microscopic debris so gently wiping with a soft cloth should remove most particles. Wipe in a straight line from the inside to the outside of the disc. Small dust particles and light stains will have absolutely no effect on reproduction quality.

Never use chemicals such as record sprays, antistatic sprays, benzene, or thinners to clean compact discs. These chemicals can damage the disc's surface.

Discs should be returned to their cases after use. This avoids serious scratches that could cause the Laser pickup to skip.

Do not expose discs to direct sunlight, high humidity, or high temperatures for extended periods. Long exposure to high temperatures can warp the disc.

Do not stick paper or write anything with a ballpoint pen on the label side of the disc.

LOADING AND UNLOADING COMPACT DISCS

LOADING AND UNLOADING COMPACT DISCS

- Press the STANDBY button to turn the unit on.
- Slide the FUNCTION Switch to the CD position.
- Press the right side of the CD door, labelled "PUSH OPEN/CLOSE" to open the CD compartment.
- When the disc compartment has opened, insert the disc with the label side facing up. Push down in the centre until disc is locked in place.
- Close the disc compartment by pressing the "PUSH OPEN/CLOSE". When the compartment is fully closed, the disc will start turning automatically. The total number of tracks will appear in the display.
- The disc compartment may be opened at any time by first pressing the stop button and then pressing the "PUSH OPEN/CLOSE". Remove the CD only after the compartment has fully opened.

CAUTION

Do not put anything except a compact disc into the compartment. Foreign objects can damage the mechanism.

Keep the disc compartment closed when not in use to prevent dirt and dust from entering the mechanism.

Never place more than one disc into the disc compartment at any time.

If the disc is correctly loaded, the total number of tracks on the disc will be displayed:

Notes: After the disc compartment is fully closed, the disc information may not appear on the display. This means that the disc is improperly loaded (most likely it is upside down). To check, open the disc compartment again and reload the disc.

DISC PLAY

- Insert a CD as described in the previous section and close the disc compartment.
- The display will then show the total number of tracks.
- Press the PLAY/PAUSE button to start playback.
- Adjust the VOLUME control as desired.
To skip forward or backward through the tracks on the disc, press the SKIP forward / backward buttons.
- When the disc is through playing, it will stop. Press STOP button to stop disc before it is finished.

Notes:

- If the disc is deeply scratched, or too dirty, disc play may not start. If an improperly centred disc is played, noise can be heard in the mechanism. The use of such discs should be avoided.
- If the disc is inserted incorrectly, or the disc is damaged the display will show "No disc".

DISC ERRORS

This compact disc player has built-in error compensation circuits to correct for minor defects in a disc. There are limits, however, to the amount of correction available.

In some cases, the CD player may skip some tracks, or parts of tracks, on a disc during disc play. This problem may be caused by defects (such as scratches) in the disc being played, which are too large for the error compensation circuits to handle. If you encounter this problem, check the CD player's operation as follows, before having the unit serviced:

Play a new disc. If the CD player operates normally, the skipping problem is probably due to a defective disc.

To STOP A CD PART WAY THROUGH

Press the STOP button. Disc play will stop and the display will show the total number of tracks

To temporarily stop disc play (pause mode), press the Play/Pause button. Disc play will stop at the current play position. The track playing time will flash.

To resume disc play, press the PLAY/PAUSE button again.

REPEAT DISC PLAY

Use the REPEAT button to listen to an entire disc, one track repetitively.

FOR REPEAT PLAY OF ONE OF THE TRACKS

- With a CD inserted, slide the FUNCTION switch to the CD position.
- Press the REPEAT button once. The REPEAT indicator will blink.
- Press the Play/Pause button and the unit will then play the same track over and over until the STOP button is pressed.
- Adjust the VOLUME control as desired.
- If the REPEAT button is pressed 2 more times during play, the REPEAT indicator will go off, Repeat Mode will end and normal playback will resume from that point.

FOR REPEAT PLAY OF ALL THE TRACKS

- Press the Repeat button twice. The REPEAT indicator will light up.
- Press the Play/Pause button and the unit will then play all the tracks on the CD over and over until the STOP button is pressed.
- Adjust the VOLUME control as desired.
- If the REPEAT button is pressed 1 more time during play, the REPEAT indicator will go off, Repeat Mode will end and normal playback will resume from that point.

PROGRAMMED DISC PLAY

- Insert a CD as described in the previous section and close the disc compartment.
- Slide the FUNCTION switch to the CD position.
- Press the PROGRAM button, "P 01" will show on the display, select the first track to be played back using the SKIP forward/backward buttons, then press the PROGRAM button again.
- Repeat this step to program additional tracks up to a maximum of 20 tracks.
- Press the PLAY/PAUSE button to begin Program playback and adjust the VOLUME control as desired.
- To skip forward or backward through the programs, press the SKIP buttons.
- When the disc is through playing, it will stop.

- Notes:*
- Press the STOP button to stop the program before it is finished.
 - To clear the memorized tracks, press the PROGRAM button to enter the Program mode (PROGRAM indicator will blink) and then press STOP button or open the CD door as explained.
 - Programming is the ability to select the order in which a series of tracks will be played.
 - Each track may be stored in the program memory as many times as desired (up to 20 tracks).
 - To repeatedly play the memorized tracks, press the REPEAT button twice; the REPEAT indicator will light.

CLOCK SETTING

To SET OR RESET THE ACTUAL TIME

- To set the minute: Press and hold the CLOCK ADJ button, then press the SKIP ◀/M button until the present minute appears in the display.
- To set the hour: Press and hold the CLOCK ADJ button, then press SKIP ▶/H button until the present hour appears in the display.

To SET OR RESET THE ALARM TIMES

- Slide the ALARM 1 or ALARM 2 switch to the ADJ position, the Alarm time will blink in the display.
- To set the wake minute: Press the SKIP ◀/M button until the desired wake minute appears in the display.
- To set the wake hour: Press the SKIP ▶/H button until the desired wake hour appears in the display.
- Slide the desired alarm switch (1 or 2) to the ON (Set) or OFF (Not Set) position.

- Notes:*
- When the ALARM 1 or ALARM 2 switch is in the SET position, all CD and function buttons will not operation, so make sure to return the switch to the NO or OFF position after setting the alarm time(s).
 - This unit has 2 alarms, each can be set for a different wake time.

To SET THE ALARM TO WAKE TO BUZZER

- Set the alarm time as previously instructed.
- Slide the BUZZER/MUSIC switch to the BUZZER position. When the actual time matches one of the selected preset alarm times, the buzzer will sound for 60 minutes and then shuts off.

To SET THE ALARM TO WAKE TO RADIO

- Set the alarm time as previously instructed. Slide the FUNCTION switch to the AM or FM position.
- Select a radio station and make sure the volume is set as desired.
- Make sure the power is off (STANDBY/ON indicator is NOT lit). Slide the BUZZER/MUSIC switch to the MUSIC position. When the actual time matches one of the selected preset alarm times, the unit automatically turns on for 60 minutes and then shuts off.

To SET THE ALARM TO WAKE TO CD

- Set the alarm time as previously instructed. Slide the FUNCTION switch to the CD position.
- Insert a CD and make sure the volume is set as desired.
- Make sure the power is off (STANDBY/ON indicator is NOT lit). Slide the BUZZER/MUSIC switch to the MUSIC position. When the actual time matches one of the selected preset alarm times, the unit automatically turns on for 60 minutes and then shuts off.

Note: - When the disc is through playing it will stop.

To SHUT THE ALARM OFF

- To shut the alarm off, press the STANDBY/ON button once and the alarm time will be reset for the next day. Slide the desired ALARM 1 or ALARM 2 switch to the OFF position to turn off the alarm and not set it for the next day.
- The alarm can be temporarily turned off manually by pressing the SNOOZE button; the alarm will turn back on automatically 6 minutes later.

To ACTIVATE THE SLEEP FUNCTION

- Tune the desired radio station or insert a CD previously instructed.
- Press the SLEEP button and “ - - “ will appear on the clock display. Repeatedly press the SLEEP button for the desired sleep time of 90, 60 or 30 minutes. The SLEEP indicator will light to indicate the Sleep mode is activated. The sleep time will internally count down and then turn off when the desired amount of time has passed.
- To turn the Sleep mode off, either press the STANDBY/ON button, which will turn the unit off, or press the SLEEP button until “ - - “ appears on the display to keep the radio/CD on, but cancel the Sleep mode.

HEADPHONE

Headphones should have a 3.5mm diameter stereo plug and an impedance of 8-32 ohms. When headphones are connected, the speakers are automatically disconnected.

MAINTENANCE AND CARE

Electronic products of this kind should never be subjected to extreme temperatures or high humidity. For instance, this set should not be placed in bathing areas or around stoves and radiators.

If necessary, clean the unit with a piece of cloth dampened with water only (Be sure the AC Power Cord is disconnected from the Mains). Never use a polish or a strong detergent as this will damage the finish of the cabinet.

This equipment has been designed and manufactured to meet the highest international standards, but, like any electrical apparatus which is operated at mains voltage, care must be taken if you are to obtain the best results and safety is to be assured. This is particularly important with audio equipment.

- DO . . . read the operating instructions before you attempt to use the equipment.
- DO . . . ensure that all electrical connections (including the mains plug, extension leads and interconnections between pieces of equipment) are properly made and in accordance with the manufacturer's instructions. Check that the mains fuse rating is correct.
- DO . . . always consult your dealer if you are ever in doubt about the installation, operation or safety of your equipment. He is the best person to advise you.
- DONOT... obstruct the necessary all-round ventilation - especially DON'T stand the set close to curtains or on soft furnishing such as carpets. Overheating can cause unnecessary damage and shorten the life of the set.

Remember that to obtain the best performance and lasting satisfaction from your equipment, have it regularly maintained by a reliable service organization. Ensure that it is correctly used by all the family.

ABOVE ALL:-

Never let children push anything into holes or slots in the case - this could result in an electric shock; Never guess or take chances with electrical equipment of any kind - it is better to be safe than sorry!