

Amana®

Heating • Air Conditioning

A higher standard of comfort

MODELS PGC(24-60)B and PGB58B

Gas-Electric Package Unit Cooling and Heating Installation Instructions

Table of Contents

I. Unit Specifications	2
II. Safety Information	6
III. General Information	7
IV. Rigging and Handling	9
V. Gas Piping	10
VI. Electrical Wiring	12
VII. Circulating Air and Filters	13
VIII. Flue Vent	16
IX. Condensate Drain	16
X. Heating Sequence of Operations	18
XI. Cooling Sequence of Operations	18
XII. Startup and Adjustment	18
XIII. Maintenance	24
XIV. Accessories and Functional Parts	26
XV. Typical Cooling Performance Data	27
XVI. Wiring Diagram	29

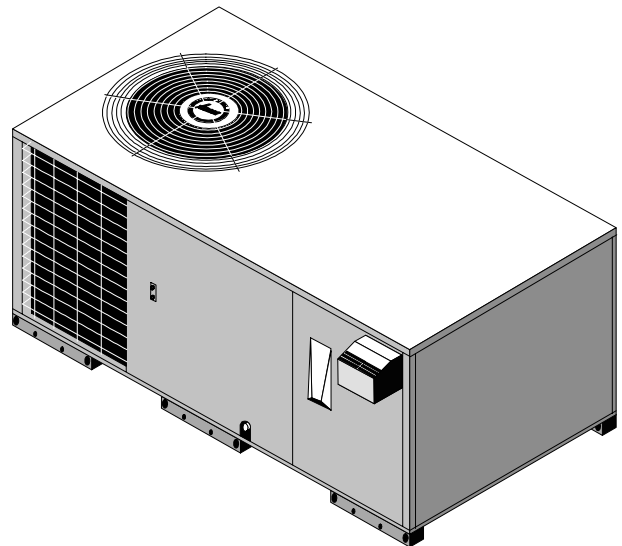

RECOGNIZE THIS SYMBOL AS A SAFETY PRECAUTION

ATTENTION INSTALLING PERSONNEL

As a professional installer you have an obligation to know the product better than the customer. This includes all safety precautions and related items.

Prior to actual installation, thoroughly familiarize yourself with this Instruction Manual. Pay special attention to all safety warnings. Often during installation or repair it is possible to place yourself in a position which is more hazardous than when the unit is in operation.

Remember, it is your responsibility to install the product safely and to know it well enough to be able to instruct a customer in its safe use.

Safety is a matter of common sense...a matter of thinking before acting. Most dealers have a list of specific good safety practices...follow them.

The precautions listed in this Installation Manual should not supersede existing practices but should be considered as supplemental information.

Affix These Installation Instructions Adjacent To The Appliance.

I. Unit Specifications

MODEL	PGC24B0452A	PGC24B0702A	PGC30B0702A	PGC36B0702A	PGC36B0902A
Cooling Capacity Btuh	24,000	24,000	30,000	36,000	36,000
SEER	12.50	12.50	12.30	12.00	12.00
Heating					
Input Btuh	45,000	70,000	70,000	70,000	90,000
Output Btuh	35,000	55,000	55,000	55,000	70,000
AFUE	80.9	80.1	80.1	80.1	80.4
Temperature Rise °F	20-50	30-60	30-60	30-60	40-70
Number of Burners	2	3	3	3	4
Compressor					
R.L. Amps	12.9	12.9	15	20	20
L.R. Amps	62.5	62.5	76	90.5	90.5
Condenser Coil					
Face Area (sq. ft.)	12.3	12.3	12.3	14	14
Rows Deep	1 1/2	1 1/2	2	2	2
Fins/Inch	13	13	13	13	13
Condenser Fan					
Diameter (in.)	20	20	20	20	20
CFM	2670	2670	2700	3060	3060
Condenser Fan Motor					
Horsepower	1/8	1/8	1/4	1/4	1/4
R.L. Amps	0.8	0.8	1.2	1.5	1.5
L.R. Amps	1.5	1.5	3	3.4	3.4
Blower Motor					
Horsepower	0.5	0.5	0.5	0.5	0.5
R.L. Amps	4.3	4.3	4.3	4.3	4.3
L.R. Amps	Protected by redundant electronic control circuits				
Blower Wheel Dia. x Width (in.)	10x7	10x7	10x7	10x7	10x7
Rated CFM, Cooling	850	850	1100	1300	1300
Max. External	0.8" wc	0.8" wc	0.8" wc	0.8" wc	0.8" wc
Combustion Blower					
Diameter x Width (in.)	4 x 1.25	4 x 1.25	4 x 1.25	4 x 1.25	4 x 1.25
No.	1	1	1	1	1
Condenser Blower Motor					
H.P.	0.03125	0.03125	0.03125	0.03125	0.03125
F.L. Amps.	0.5	0.5	0.5	0.5	0.5
Press. Switch Setting (" W.C.)	-0.65	-0.65	-0.65	-0.65	-0.65
Ignition - Lockout Timing (sec.)	4	4	4	4	4
Flame Sense Current (microamps)					
Minimum	1	1	1	1	1
Maximum	6	6	6	6	6
Evaporator Coil					
Face Area (Sq. Ft.)	4	4	4	4	4
Rows Deep	2	2	2	4	4
Fins/Inch	16	16	16	12	12
External Filter Size (Sq. Ft.)	3.6	3.6	3.6	3.6	3.6
Drain Line Size (in.)	3/4	3/4	3/4	3/4	3/4
Expansion Device (Cooling)	Capillary	Capillary	Capillary	Capillary	Capillary
Refrigerant Charge	Refer to unit name plate for correct charge				
Power Supply**	208/230-60-1	208/230-60-1	208/230-60-1	208/230-60-1	208/230-60-1
Min. Circuit Ampacity	21.3	21.3	24.3	30.8	30.8
Max. Overcurrent Device	30	30	35	45	45
Electrical Entrance Size					
Power Supply	1 1/4", 1 1/2", 2"	1 1/4", 1 1/2", 2"	1 1/4", 1 1/2", 2"	1 1/4", 1 1/2", 2"	1 1/4", 1 1/2", 2"
Low Voltage	7/8"	7/8"	7/8"	7/8"	7/8"
Approx. Shipping Weight (lb.)	385	394	418	437	443

1) United States Installation

2) Specification subject to change without notice. See sales specification sheets for certain BTUH capacities.

3) This PGC series complies with requirements embodied in the American National Standard ANSI-Z21.47 Central Furnaces.

4) Filters are not supplied with units, but filters must be installed in the unit filter rack or in the return air system.

** While the above data is presented as a guide, it is important to electrically connect the unit and properly size overcurrent protection and wires in accordance with the National Electrical Code and all existing local codes.

Operating tolerance: Minus 5% on 208 VAC, Plus 10% on 208 VAC and 230 VAC, Minus 10% on 230 VAC

**Table 1A
Gas Pack Specifications**

MODEL	PGC42B0902A	PGC42B1152A	PGC48B0902A	PGC48B1152A	PGC60B0902A	PGC60B1352A
Cooling Capacity Btuh	42,000	42,000	48,000	48,000	60,000	60,000
SEER	12.20	12.20	12.00	12.00	12.00	12.00
Heating						
Input Btuh	90,000	115,000	90,000	115,000	90,000	135,000
Output Btuh	72,000	89,000	72,000	89,000	72,000	108,000
AFUE	81.4	79.9	81.4	79.9	81.4	80.5
Temperature Rise °F	25-55	40-70	25-55	40-70	25-55	40-70
Number of Burners	4	5	4	5	5	6
Compressor						
R.L. Amps	22	22	21.8	21.8	28.8	28.8
L.R. Amps	107	107	105	105	169	169
Condenser Coil						
Face Area (sq. ft.)	17.2	17.2	17.2	17.2	17.2	17.2
Rows Deep	2	2	2	2	2	2
Fins/Inch	13	13	17	17	17	17
Condenser Fan						
Diameter (in.)	24	24	24	24	24	24
CFM	3500	3500	3700	3700	4700	4700
Condenser Fan Motor						
Horsepower	1/4	1/4	1/2	1/2	1/3	1/3
R.L. Amps	1.5	1.5	1.5	1.5	2.5	2.5
L.R. Amps	3.4	3.4	3.6	3.6	6.4	6.4
Blower Motor						
Horsepower	3/4	3/4	3/4	3/4	1	1
R.L. Amps	5	5	5	5	7	7
L.R. Amps	Protected by redundant electronic control circuits					
Blower Wheel Dia. x Width (in.)	10x10	10x10	10x10	10x10	11x8	11x8
Rated CFM, Cooling	1450	1450	1700	1700	1750	1750
Max. External	0.8" wc	0.8" wc	0.8" wc	0.8" wc	0.8" wc	0.8" wc
Combustion Blower						
Diameter x Width (in.)	4 x 1.25	4 x 1.25	4 x 1.25	4 x 1.25	4 x 1.25	4 x 1.25
No.	1	1	1	1	1	1
Condenser Blower Motor						
H.P.	0.03125	0.03125	0.03125	0.03125	0.03125	0.03125
F.L. Amps.	0.5	0.5	0.5	0.5	0.5	0.5
Press. Switch Setting (" W.C.)	-0.65	-0.65	-0.65	-0.65	-0.65	-0.65
Ignition - Lockout Timing (sec.)	4	4	4	4	4	4
Flame Sense Current (microamps)						
Minimum	1	1	1	1	1	1
Maximum	6	6	6	6	6	6
Evaporator Coil						
Face Area (Sq. Ft.)	5.7	5.7	5.7	5.7	5.7	5.7
Rows Deep	2	2	3	3	3	3
Fins/Inch	15	15	15	15	15	15
External Filter Size (Sq. Ft.)	5.3	5.3	5.3	5.3	5.3	5.3
Drain Line Size (in.)	3/4	3/4	3/4	3/4	3/4	3/4
Expansion Device (Cooling)	Capillary	Capillary	TEV	TEV	TEV	TEV
Refrigerant Charge						
Refer to unit name plate for correct charge						
Power Supply**	208/230-60-1	208/230-60-1	208/230-60-1	208/230-60-1	208/230-60-1	208/230-60-1
Min. Circuit Ampacity	34	34	39.5	39.5	49.7	49.7
Max. Overcurrent Device	50	50	50	50	70	70
Electrical Entrance Size						
Power Supply	1 1/4", 1 1/2", 2"	1 1/4", 1 1/2", 2"	1 1/4", 1 1/2", 2"	1 1/4", 1 1/2", 2"	1 1/4", 1 1/2", 2"	1 1/4", 1 1/2", 2"
Low Voltage	7/8"	7/8"	7/8"	7/8"	7/8"	7/8"
Approx. Shipping Weight (lbs)	521	527	526	526	531	531

1) United States Installation

2) Specification subject to change without notice. See sales specification sheets for certain BTUH capacities.

3) This PGC series complies with requirements embodied in the American National Standard ANSI-Z21.47 Central Furnaces.

4) Filters are not supplied with units, but filters must be installed in the unit filter rack or in the return air system.

** While the above data is presented as a guide, it is important to electrically connect the unit and properly size overcurrent protection and wires in accordance with the National Electrical Code and all existing local codes.

Operating tolerance: Minus 5% on 208 VAC, Plus 10% on 208 VAC and 230 VAC, Minus 10% on 230 VAC

**Table 1B
Gas Pack Specifications**

MODEL	PGB58B0902A	PGB58B1152A	PGB58B1352A
Cooling Capacity Btuh	59,500	59,500	59,500
SEER	11.10	11.10	11.10
Heating			
Input Btuh	90,000	115,000	135,000
Output Btuh	72,000	92,000	108,000
AFUE	81.4	79.9	80.5
Temperature Rise °F	25-55	25-55	25-55
Number of Burners	4	4	4
Compressor			
R.L. Amps	28.8	28.8	28.8
L.R. Amps	169	169	169
Condenser Coil			
Face Area (sq. ft.)	17.2	17.2	17.2
Rows Deep	2	2	2
Fins/Inch	17	17	17
Condenser Fan			
Diameter (in.)	24	24	24
CFM	4700	4700	4700
Condenser Fan Motor			
Horsepower	1/3	1/3	1/3
R.L. Amps	2.5	2.5	2.5
L.R. Amps	6.4	6.4	6.4
Blower Motor			
Horsepower	3/4	3/4	3/4
R.L. Amps	5.6	5.6	5.6
L.R. Amps	12.9	12.9	12.9
Blower Wheel Dia. x Width (in.)	11X8	11X8	11X8
Rated CFM, Cooling	1750	1750	1750
Max. External	0.5" wc	0.5" wc	0.5" wc
Combustion Blower			
Diameter x Width (in.)	4 x 1.25	4 x 1.25	4 x 1.25
No.	1	1	1
Condenser Blower Motor			
H.P.	1/32	1/32	1/32
F.L. Amps.	0.5	0.5	0.5
Press. Switch Setting (" W.C.)	-0.65	-0.65	-0.65
Ignition - Lockout Timing (sec.)	4	4	4
Flame Sense Current (microamps)			
Minimum	1	1	1
Maximum	6	6	6
Evaporator Coil			
Face Area (Sq. Ft.)	5.7	5.7	5.7
Rows Deep	4	4	4
Fins/Inch	15	15	15
External Filter Size (Sq. Ft.)			
Drain Line Size (in.)	3/4	3/4	3/4
Expansion Device (Cooling)	TEV	TEV	TEV
Refrigerant Charge	Refer to unit name plate for correct charge		
Power Supply**	208/230-60-1	208/230-60-1	208/230-60-1
Min. Circuit Ampacity	33.75	33.75	33.75
Max. Overcurrent Device	50	50	50
Electrical Entrance Size			
Power Supply	1 1/4", 1 1/2", 2"	1 1/4", 1 1/2", 2"	1 1/4", 1 1/2", 2"
Low Voltage	7/8"	7/8"	7/8"
Approx. Shipping Weight (lbs)	531	531	531

**Table 1C
Gas Pack Specifications**

Model	Nominal Cooling Capacity (MBh)	Nominal Cooling CFM	Nominal Heating Capacity (Input)	Nominal Heating CFM	Nominal Fan Only	Temp. Rise (°F)	Speed Taps	
		(Y+G)		(W1)	(G)		Cool	Heat
PGC24B0452A	24000	850	45000	930	570	35	A	A
PGC24B0702A	24000	850	70000	1140	570	45	A	B
PGC30B0702A	30000	1100	70000	1140	570	45	B	B
PGC36B0702A	36000	1300	70000	1140	570	45	C	B
PGC36B0902A	36000	1300	90000	1350	570	55	C	C
PGC42B0902A	42000	1450	90000	1650	815	40	A	A
PGC42B1152A	42000	1450	115000	1530	815	55	A	B
PGC48B0902A	48000	1700	90000	1650	815	40	B	A
PGC48B1152A	48000	1700	115000	1530	815	55	B	B
PGC60B0902A	60000	1750	90000	1650	815	40	A	A
PGC60B1352A	60000	1750	135000	1900	815	55	A	B

1. Installation is to be adjusted to obtain temperature rise within the range specified on the rating plate.
2. The temperature rise is for units installed at 0-2000 feet. At higher altitudes, a properly derated unit will have approximately the same temperature rise and CFM.
3. The chart is applicable for both vertical and horizontal airflow.
4. All speed tap settings are factory selected according to unit size.
5. Data shown without filters. Consult filter manufacturer for pressure drop to be added.
6. Motor is constant CFM for external static pressures 0.1" to 0.8" W.C.
7. Maximum External Pressure Limits
PGC 24-42 0.8" W.C.
PGC46 & 60 1.0 W.C.

**Table 2A
PGC Temperature Rise Table**

Model	Motor Speed	External Static Pressure, Inches Water Column															
		0.1		0.2		0.3		0.4		0.5		0.6		0.7		0.8	
		CFM	RISE	CFM	RISE	CFM	RISE	CFM	RISE	CFM	RISE	CFM	RISE	CFM	RISE	CFM	RISE
PGB58B0902C	Hi	2160	31	2120	31	2080	32	2030	33	1990	34	1945	34	1900	35	1835	36
	Med	1750	38	1750	39	1700	39	1680	40	1680	40	1615	41	1575	42	1490	45
	Lo	1490	45	1480	45	1470	45	1450	46	1440	46	1415	47	1360	49	1280	52
PGB58B1152C	Hi	2160	---	2120	---	2080	41	2030	42	1990	43	1945	44	1900	45	1835	46
	Med	1750	49	1750	49	1700	50	1680	51	1650	52	1615	53	1575	54	1470	57
	Lo	1490	57	1480	58	1470	58	1460	58	1440	59	1415	60	1360	63	1280	67
PGB58B1352C	Hi	2160	46	2120	47	2080	48	2030	49	1990	50	1945	51	1900	53	1835	54
	Med	1750	57	1750	58	1700	59	1680	60	1650	61	1615	62	1575	63	1490	67
	Lo	1490	67	1480	68	1470	68	1460	68	1440	69	1415	---	1360	---	1280	---

NOTE:

1. All airflow is dry coil.
2. Installation is to be adjusted to obtain temperatures rise within the range specified on the rating plate.
3. The above chart is for information only. For satisfactory operation, external static pressure should not exceed value shown on the rating plate. The shaded area (■) indicates in excess of maximum external static pressure allowable when heating.
4. This chart is for units installed at 0-2000 feet. At higher altitudes, a properly derated unit will have approximately the same temperature rise at a particular CFM, while ESP at that CFM will be lower.
5. Cooling operation may require a different fan speed than heating operation. For details, see Wiring Diagrams.
6. Above chart is applicable for both vertical and horizontal airflow.

**Table 2B
PGB CFM & Temperature Rise vs. External Static Pressure Table**

II. Safety Information

Important

To The Installer

Before installing this unit please read this manual to familiarize yourself with the specific items which must be adhered to such as maximum external static pressure to unit, air temperature rise, minimum or maximum CFM and motor speed connections. Affix these Installation Instructions adjacent to the appliance.

To The Owner

It is important that you complete the owner registration card and mail it today. This will assist Amana in contacting you if any service or warranty information should change in the future. When completing the registration card, be sure to include the Model, Manufacturing and Serial Numbers, plus the installation date.

Your warranty certificate is also supplied with the unit. Read the warranty carefully and note what is covered. Keep the warranty certificate in a safe place so you can find it if necessary.

If additional operating Instructions are required, call the dealer where the purchase was made. Keep this literature in a safe place for future reference.



WARNING

Should overheating occur or the gas supply fail to shut off, turn off the manual gas control valve to the furnace before shutting off the electrical supply.



CAUTION

On PGC48 - 60 and PGB58 Only: To avoid damage to the compressor, engage the electrical disconnect switch to the compressor unit four hours prior to operating air conditioner after the electrical disconnect is off for a prolonged period of time (during vacation, etc.). This time lapse allows the compressor crankcase to attain a proper operating temperature.



WARNING

If the information in this manual is not followed exactly, a fire or explosion may result causing property damage, personal injury, or death.



WARNING

Do not store gasoline or other flammable vapors and liquids in the vicinity of this or any other appliance.

If you smell gas:

- Extinguish any open flame.
- Do not try to light appliance.
- Do not touch any electrical switch: do not use any phone in building.
- Immediately call gas supplier from a neighbor's phone. Follow gas supplier's instructions.
- If gas supplier cannot be reached, call fire department.



WARNING

Improper installation, adjustment, alterations, service or maintenance can cause property damage, personal injury, or death. Follow all procedures in this manual. For assistance or additional information, contact a qualified installer, service agency, or gas supplier.



WARNING

This product contains or produces a chemical(s) which may cause death or serious illness and which are known by the State of California to cause cancer, birth defects or other reproductive harm.



CAUTION

This unit should not be used as a "construction heater" during the finishing phases of construction on a new structure. This type of use may result in premature failure of the unit due to extremely low return air temperatures and exposure to very dirty atmospheres.

Locating The Unit



WARNING

To avoid possible equipment damage, fire, personal injury, or death, the following points must be observed when installing the unit.

All Installations:

- For proper flame pattern within the heat exchanger and proper condensate drainage, the unit must be mounted level.
- The unit should be as centralized as is practical with respect to the air distribution system. This unit is for outdoor installation ONLY!
- The flue outlet hood must be at least 12 inches from any opening through which flue gases could enter a building, and at least three feet above any forced air inlet located within ten feet. The economizer/manual outdoor air intake/motorized outdoor air intake and combustion air inlet mounted on the unit are not affected by this restriction.
- To avoid possible corrosion of the heat exchanger, do not locate the unit in an area where the outdoor air (i.e., combustion air for the unit) will be frequently contaminated by compounds containing chlorine or fluorine. Common sources of such compounds include swimming pools and chlorine bleaches, paint stripper, adhesives, paints, varnishes, sealers, waxes (which are not yet dried) and solvents used during construction and remodeling. Various commercial and industrial processes may also be sources of chlorine/fluorine compounds.
- To avoid possible illness or death of the building occupants, do NOT locate outside air intake device (economizer, manual outdoor air intake, motorized outdoor air intake) too close to an exhaust outlet, gas vent termination, or plumbing vent outlet. For specific distances required, consult local codes.
- Allow clearances from the enclosure as shown in Figure 1 for fire protection, proper operation, and service access. These clearances must be permanently maintained.
- The combustion air inlet and flue outlet hoods on the front of the unit must never be obstructed. If used, do not allow the economizer/manual outdoor air damper/ motorized outdoor air damper to become blocked by snow or debris. In some climates or locations, it may be necessary to elevate the unit to avoid these problems.
- When the unit is heating, the temperature of the return air entering the unit must be between 50° F and 100° F.

Ground Level Installations Only:

- When the unit is installed on the ground adjacent to the building, a level concrete (or equal) base is recommended. Prepare a base the same physical size as the unit or slightly larger and 3 inches thick.
- The base should also be located where no run-off of water from higher ground can collect in the unit.
- The feet on the unit may not be removed.

Rooftop Installations Only:

- To avoid possible property damage or personal injury, the roof must have sufficient structural strength to carry the weight of the unit(s) and snow or water loads as required by local codes.
- If horizontal air delivery is used, the unit may be installed directly on wood floors or on Class A, Class B, or Class C roof covering material, provided that the feet on the unit are not removed.
- To avoid possible personal injury, a safe, flat surface for service personnel should be provided.
- If vertical air discharge is used and the unit is installed on combustible flooring or class A, B, or C roofing material, then the Amana roof curb (PRC3A or PRC5A) listed on the unit nameplate is required.

III. General Information



WARNING

Improper installation, repair, operation or maintenance of this product may result in property damage, personal injury, or death from hazards such as fire, explosions, smoke, soot, condensation, electric shock or carbon monoxide.

This unit is approved only for an outdoor installation. To assure that your unit operates safely and efficiently, it must be installed, operated, and maintained in accordance with these installation and operating instructions, all local building codes and ordinances, or in their absence, with the latest edition of the National Fuel Gas Code. (ANSI Z223.1).

The heating and cooling capacities of the unit should be greater than or equal to the design heating and cooling loads of the area to be conditioned. The loads should be calculated by an approved method or in accordance with ASHRAE Guide or Manual J - Load Calculations published by the Air Conditioning Contractors of America.

Obtain from:

American National Standards Institute
1430 Broadway
New York, NY 10018

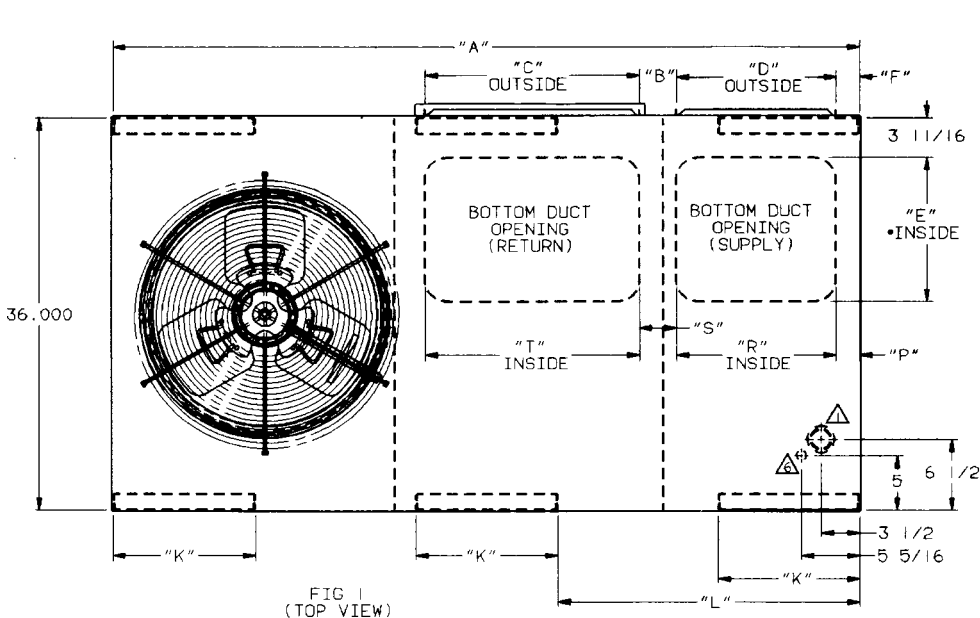

Dimension	Unit Size	
	36	48,60
A (Length)	68 ⁷ / ₁₆ "	81 ¹ / ₂ "
B	3 ⁹ / ₁₆ "	3 ⁹ / ₁₆ "
C	19 ¹ / ₁₆ "	22 ¹ / ₁₆ "
D	14 ¹ / ₁₆ "	17 ¹ / ₁₆ "
E	13 ¹ / ₈ "*	17 ¹ / ₈ "*
F	2 ³ / ₁₆ "	3 ⁷ / ₁₆ "
G	15 ³ / ₁₆ "	21 ⁷ / ₁₆ "
H	2 ¹ / ₈ "	2 ¹ / ₈ "
J	5 ⁹ / ₁₆ "	8 ⁹ / ₁₆ "
K	13"	13"
L	27 ¹ / ₁₆ "	34 ¹ / ₄ "
M	13 ³ / ₁₆ "	17 ³ / ₁₆ "
N (Height w/o Rails)	28 ¹³ / ₁₆ "	35 ⁵ / ₁₆ "
P	2 ³ / ₁₆ "	3 ⁷ / ₁₆ "
R	14 ⁵ / ₈ "*	17 ⁵ / ₈ "*
S	3 ³ / ₈ "	3 ¹ / ₁₆ "
T	16 ⁵ / ₈ "*	22 ⁵ / ₈ "*

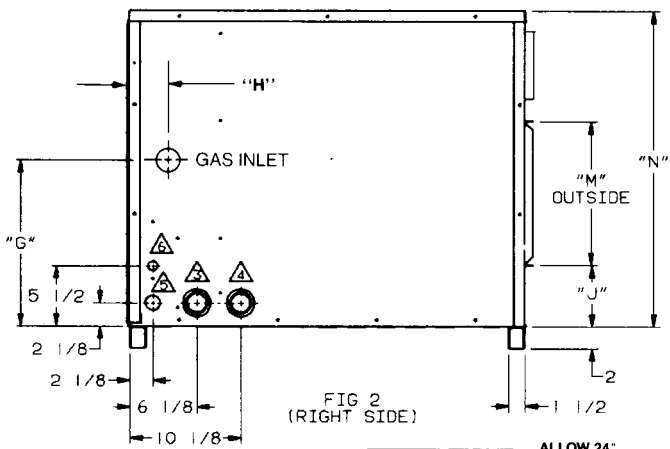

KNOCKOUT GROMMET DIMENSIONS		
Knockouts	Trade Size Conduit	Voltage
△	1 ¹ / ₄ ", 1 ¹ / ₂ ", 2"	Line
△	Not Used	NA
△	1 ¹ / ₄ ", 1 ¹ / ₂ ", 2"	Line
△	1 ¹ / ₄ ", 1 ¹ / ₂ ", 2"	Line
△	1"	Line
△	1/2"	Low

*NOTE: Bottom duct openings have rounded rather than square openings. If using bottom discharge, ductwork should be attached to the curb prior to installing the unit. Ductwork dimensions are shown in Amana roof curb installation instructions.

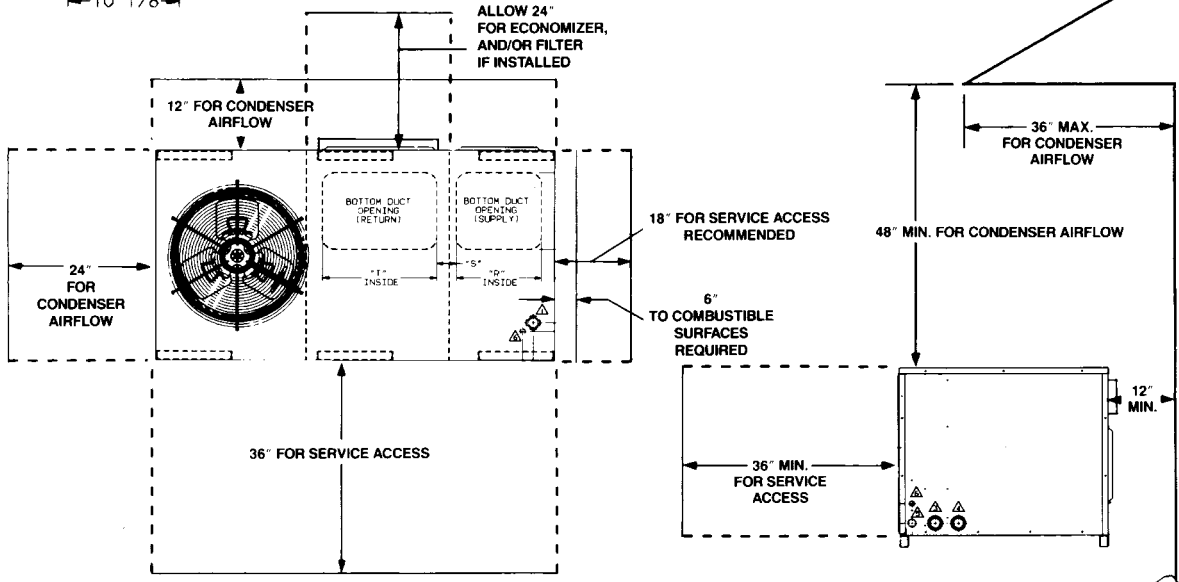

Figure 1
Required Clearances For All Installations

Transportation Damage

All units are securely packed in shipping cartons approved by the International Safe Transit Association. The carton should be checked upon arrival for external damage. If damage is found, a request for inspection by carrier agent should be made in writing immediately.

The unit should be carefully inspected upon arrival for damage and bolts or screws which may have loosened in transit. In the event of damage, the consignee should:

1. Make notation on delivery receipt of any visible damage to shipment or container.
2. Notify carrier promptly and request an inspection.
3. In case of concealed damage, carrier should be notified as soon as possible-preferably within 5 days.
4. File the claim with the following supporting documents within the 9-month statute of limitations.
 - a. Original Bill of Lading, certified copy, or indemnity bond.
 - b. Original paid freight bill or indemnity in lieu thereof.
 - c. Original invoice or certified copy thereof, showing trade and other discounts or reductions.
 - d. Copy of the inspection report issued by carrier representative at the time damage is reported to the carrier. The carrier is responsible for making prompt inspection of damage and for a thorough investigation of each claim. The distributor or manufacturer will not accept claims from dealers for transportation damage.

NOTE: When inspecting the unit for transportation damage, remove all packaging materials. Follow local codes when disposing or recycling the packaging material.

Locating The Thermostat

The thermostat should be mounted 5 feet above the floor, on a vibration free inside wall in a room or a hallway that has good air circulation.

Movement of air should not be obstructed by furniture, door, draperies, etc. The thermostat should not be mounted where it will be affected by drafts, hot or cold water pipes or air ducts in walls, radiant heat from fireplace, lamps, the sun, television, etc. Consult the Instruction Sheet packaged with the thermostat for mounting instructions.

All units have one stage of heating and one stage of mechanical cooling. Units which will have economizers may use thermostats with one or two stages of cooling.

IV. Rigging and Handling

CAUTION

To prevent possible property damage, the unit should remain in an upright position during all rigging and moving operations. To facilitate lifting and moving when a crane is used, place the unit in an adequate cable slide.

Important: If using bottom discharge with roof curb, ductwork should be attached to the curb prior to installing the unit. Ductwork dimensions are shown in Amana Roof Curb Installation Instructions.

Refer to the Amana Roof Curb Installation Instructions for proper curb installation. Curbing must be installed in compliance with the National Roofing Contractors Association Manual.

Lower unit carefully onto roof mounting curb. While rigging unit, center of gravity will cause condenser end to be lower than supply air end.

If using a fork lift, see Figure 2 for location of fork prongs. Make certain prongs support unit weight.

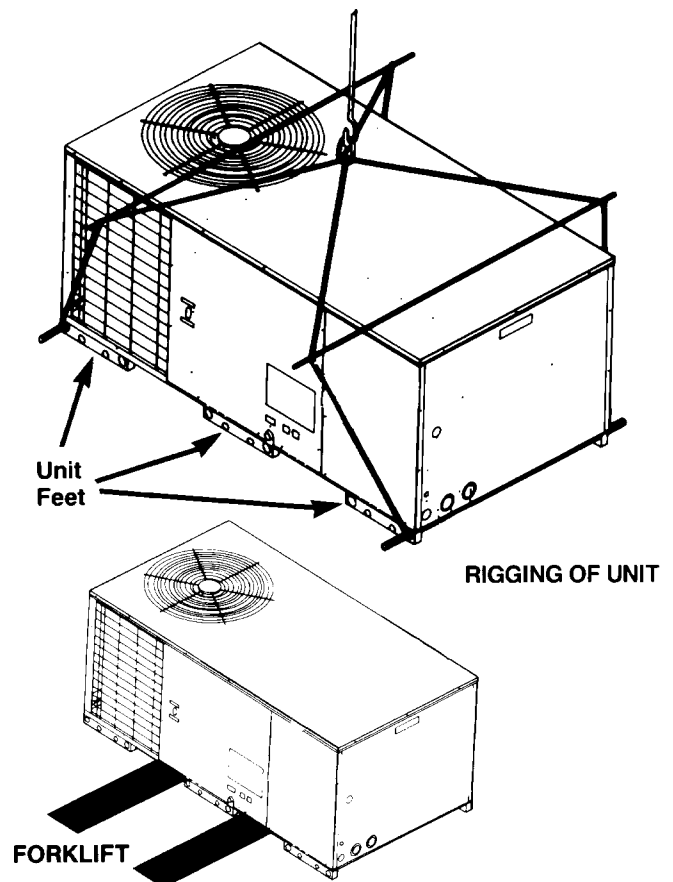

**Figure 2
Rigging**

V. Gas Piping

IMPORTANT NOTE: This furnace is factory set to operate on natural gas at the altitudes shown on the rating plate. If operation at higher altitudes and/or propane gas operation is required, obtain and install the proper conversion kit(s) before operating this furnace. Failure to do so may result in unsatisfactory operation and/or equipment damage. (High altitude kits are for U.S. installations only.)

The rating plate is stamped with the model number, type of gas and gas input rating. Make sure the furnace is equipped to operate on the type of gas available.

INLET GAS PRESSURE	
Natural	Min. 5.0" W.C., Max. 10.0" W.C.
Propane	Min. 11.0" W.C., Max. 14.0" W.C.

Inlet Gas Pressure Must Not Exceed the Maximum Value Shown in Table 3.

Table 3

The minimum supply pressure should not vary from that shown in the table above because this could prevent the furnace from having dependable ignition. In addition, gas input to the burners must not exceed the rated input shown on the rating plate. Overfiring of the furnace could result in premature heat exchanger failure.

High Altitude Derate (US. Installations Only - Canadian Installations to 4500 Feet Only)

When this furnace is installed at altitudes above 2000 feet, the furnace input must be derated 4% for each 1000 feet above sea level because the density of the air is reduced.

In some areas the gas supplier will derate the heating value of the gas at a rate of 4% for each 1000 feet above sea level. If this is not done, smaller orifices will be required at altitudes above 3500 feet (non-derated natural gas) or 4500 feet (non-derated propane gas).

A different pressure switch will be required at altitudes more than 4000 feet above sea level. This is required regardless of the heat content of the fuel used.

High altitude kits can be purchased depending on the altitude and usage of propane or natural gas. Refer to the high altitude instruction manual included with this furnace to determine which high altitude components to use.

Adjustment of the manifold pressure to a lower pressure reading than what is specified on the furnace nameplate is not a proper derate procedure. With a lower density of air and a lower manifold pressure at the burner orifice, the orifice will not aspirate the proper amount of air into the burner. This can cause incomplete combustion of the gas, flashback, and possible yellow tipping.

Gas Piping

IMPORTANT NOTE: To avoid possible unsatisfactory operation or equipment damage due to under firing of equipment, do not undersize the natural gas/propane piping from the meter/tank to the furnace. When sizing a trunk line as shown in Table 4, include all appliances on that line that could be operated simultaneously.

The rating plate is stamped with the model number, type of gas and gas input rating. Make sure the furnace is equipped to operate on the type of gas available.

The gas line installation must comply with local codes, or in the absence of local codes, with the latest edition of the National Fuel Gas Code (ANSI Z223.1).

Connecting The Gas Piping - Natural Gas

Natural Gas Capacity of Pipe in Cubic Feet of Gas Per Hour (CFH)					
Length of Pipe in Feet	Nominal Black Pipe Size (inches)				
	1/2	3/4	1	1 1/4	1 1/2
10	132	278	520	1050	1600
20	92	190	350	730	1100
30	73	152	285	590	980
40	63	130	245	500	760
50	56	115	215	440	670
60	50	105	195	400	610
70	46	96	180	370	560
80	43	90	170	350	530
90	40	84	160	320	490
100	38	79	150	305	460

Pressure = .50 PSIG or less and Pressure Drop of 0.3" W.C. (Based on 0.60 Specific Gravity Gas)

$$CFH = \frac{\text{Btuh Furnace Input}}{\text{Calorific Value of Gas}}$$

Table 4

Refer to Figure 3 for the general layout at the furnace. The following rules apply:

1. Use black iron or steel pipe and fittings for the building piping.
2. Use pipe joint compound on male threads only. Pipe joint compound must be resistant to the action of the fuel used.
3. Use ground joint unions.
4. Install a drip leg to trap dirt and moisture before it can enter the gas valve. The drip leg must be a minimum of three inches long.
5. Use two pipe wrenches when making connection to the gas valve to keep it from turning.
6. Install a manual shut-off valve in a convenient location (within six feet of unit) between the meter and the unit.
7. Tighten all joints securely.

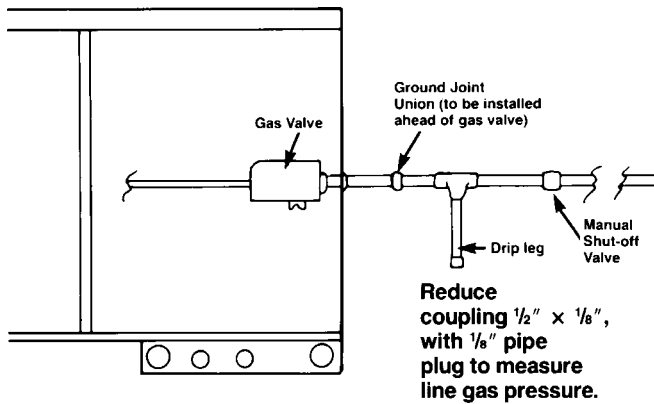

Figure 3
Proper Piping Practice

Checking The Gas Piping

CAUTION

To avoid the possibility of personal injury, property damage or fire, the following instructions must be performed regarding gas connections and pressure testing:

- This unit and its gas connections must be leak tested before placing in operation. Because of the danger of explosion or fire, never use a match or open flame to test for leaks. Never exceed specified pressures for testing. Higher pressure may damage gas valve and cause overfiring which may result in heat failure.
- This unit and shut-off valve must be disconnected from the gas supply during any pressure testing of that system at test pressures in excess of 1/2 PSIG (3.48 kPa).
- This unit must be isolated from the gas supply system by closing the manual shut-off valve during any pressure testing of the gas supply piping system at test pressures equal to or less than 1/2 PSIG (3.48 kPa).

WARNING

To avoid personal injury or property damage, be sure there is no open flame in the vicinity during air bleeding procedure.

There will be air in the gas supply line after testing for leaks on a new installation. Therefore, the air must be bled from the line by cracking open the ground joint union until pure gas is expelled. Tighten union and wait for five minutes until all gas has been dissipated in the air. Be certain there is no open flame in the vicinity during air bleeding procedure. The unit is placed in operation by closing the main electrical disconnect switch for the furnace.

Tanks And Piping for Propane Gas Units

WARNING

Personal Injury Hazard

Failure to detect a propane gas leak could result in an explosion or fire which could cause death, serious personal injury, or property damage.

Iron oxide (rust) can reduce the level of odorant in propane gas. A gas detecting device is the only reliable method to detect a propane gas leak. Contact the local propane supplier about installing a warning device to sound an alert if a gas leak should develop.

All propane gas equipment must conform to the safety standards of the National Board of Fire Underwriters (See NBFU Manual 58).

For satisfactory operation, propane gas pressure must be 10 inch W.C. at the furnace manifold with all gas appliances in operation. Maintaining proper gas pressure depends on three main factors:

1. Vaporization rate, which depends on (a) temperature of the liquid, and (b) wetted surface area of the container or containers.
2. Proper pressure regulation. (Two-stage regulation is recommended from the standpoint of both cost and efficiency.)
3. Pressure drop in lines between regulators, and between second stage regulator and the appliance. Pipe size required will depend on length of pipe run and total load of all appliances.

Complete information regarding tank sizing for vaporization, recommended regulator settings and pipe sizing is available from most regulator manufacturers and propane gas suppliers.

Special pipe dope must be used when assembling piping for this gas as it will quickly dissolve white lead or most standard commercial compounds. Shellac base compounds resistant to the actions of liquefied petroleum gases such as Gasolac, Static, Clyde or John Crane are satisfactory.

Please refer to Figure 4 for typical propane gas installations.

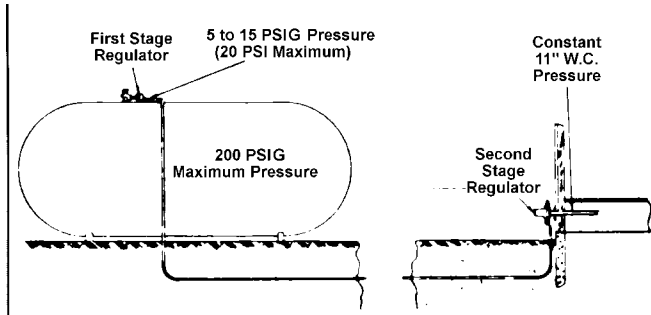

Figure 4
Typical Propane Gas Piping

Sizing Between First and Second Stage Regulator
Maximum Propane Capacities listed are based on 2 PSIG Pressure Drop at 10 PSIG Setting. Capacities in 1,000 BTU/HR

PIPE OR TUBING LENGTH, FEET	TUBING SIZE, O. D., TYPE L					NOMINAL PIPE SIZE, SCHEDULE 40	
	3/8"	1/2"	5/8"	3/4"	7/8"	1/2"	3/4"
10	730	1,700	3,200	5,300	8,300	3,200	7,500
20	500	1,100	2,200	3,700	5,800	2,200	4,200
30	400	920	2,000	2,900	4,700	1,800	4,000
40	370	850	1,700	2,700	4,100	1,600	3,700
50	330	770	1,500	2,400	3,700	1,500	3,400
60	300	700	1,300	2,200	3,300	1,300	3,100
80	260	610	1,200	1,900	2,900	1,200	2,600
100	220	540	1,000	1,700	2,600	1,000	2,300
125	200	490	900	1,400	2,300	900	2,100
150	190	430	830	1,300	2,100	830	1,900
175	170	400	780	1,200	1,900	770	1,700
200	160	380	730	1,100	1,800	720	1,500

To Convert to Capacities at 15 PSIG Settings — Multiply by 1.130
To Convert to Capacities at 5 PSIG Settings — Multiply by 0.879

Sizing Between Single or Second Stage Regulator and Appliance*
Maximum Propane Capacities Listed are Based on 1/2" W.C. Pressure Drop at 11" W.C. Setting. Capacities in 1,000 BTU/HR

PIPE OR TUBING LENGTH, FEET	TUBING SIZE, O. D., TYPE L						NOMINAL PIPE SIZE, SCHEDULE 40				
	3/8"	1/2"	5/8"	3/4"	7/8"	1-1/8"	1/2"	3/4"	1"	1-1/4"	1-1/2"
10	39	92	199	329	501	935	275	567	1,071	2,205	3,307
20	26	62	131	216	346	630	189	393	732	1,496	2,299
30	21	50	107	181	277	500	152	315	590	1,212	1,858
40	19	41	90	145	233	427	129	267	504	1,039	1,559
50	18	37	79	131	198	376	114	237	448	913	1,417
60	16	35	72	121	187	340	103	217	409	834	1,275
80	13	29	62	104	155	289	89	185	346	724	1,086
100	11	26	55	90	138	255	78	162	307	630	976
125	10	24	48	81	122	224	69	146	275	567	866
150	9	21	43	72	109	202	63	132	252	511	787
200	8	19	39	66	100	187	54	112	209	439	665
250	8	17	36	60	93	172	48	100	185	390	590

*DATA IN ACCORDANCE WITH NFPA PAMPHLET NO. 54

Table 5
Propane Pipe Sizing

! WARNING

Failure to follow the instructions on Page 6 of this manual when the presence of gas is suspected could result in death or serious personal injury. An undetected gas leak would create a danger of explosion or fire.

If the propane gas furnace is installed in an excavated area or a confined space, it is strongly recommended contacting a propane gas supplier about installing a warning device to warn of a gas leak.

Propane gas is heavier than air and any leaking gas can settle in low areas or confined areas.

Propane gas odorant may fade, making the gas undetectable except with a warning device.

VI. Electrical Wiring

! WARNING

To avoid personal injury or death due to electrical shock, disconnect the electrical power before electrically connecting the unit.

The units are designed for operation on 60 hertz current and at voltages as shown on the rating plate. All internal wiring in the unit is complete. It is necessary to bring in the power supply to the contactor as shown on the unit wiring diagram which is supplied with each unit. The 24V wiring must be connected between the unit control panel and the room thermostat. Refer to Figure 5 for location of low voltage terminal board and Figure 6 for proper thermostat wiring.

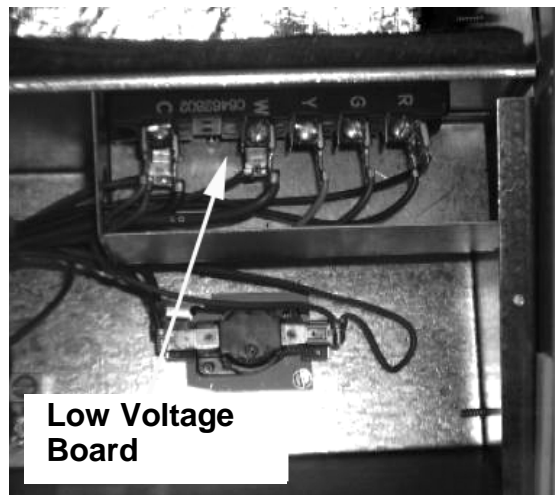

Figure 5
Low Voltage Control Box

Please refer to the unit wiring diagram for electrical connections. When installed, the unit must be electrically grounded in accordance with local codes or in the absence of local codes with the latest edition of National Electrical Code, ANSI/NFPA No. 70.

WARNING
To avoid death or personal injury due to electrical shock, wiring to the unit must be properly grounded.

CAUTION
To avoid personal injury or property damage due to fire, use only copper conductors.

The best protection for the wiring is the smallest fuse or breaker which will hold the equipment on the line during normal operation without nuisance trips. Such a device will provide maximum circuit protection. DO NOT EXCEED THE MAXIMUM OVERCURRENT DEVICE SIZE SHOWN ON UNIT DATA PLATE.

Be sure line voltage connections are made through weatherproof fittings. All exterior power supply and ground wiring must be in approved weatherproof conduit. Low voltage wiring from the unit control panel to the thermostat requires coded cable. For ground level and rooftop wiring refer to Figure 8.

Unit Voltage

The unit transformer is factory connected for 230V operation. If the unit is to operate on 208V, reconnect the transformer primary lead and induced draft blower motor leads as shown on the unit wiring diagram.

Heat Anticipator Setting

The heat anticipator in the room thermostat must be correctly adjusted to obtain the proper number of heating cycles per hour and to prevent the room temperature from overshooting the room thermostat setting. Heat anticipator must be set at 0.8 amps.

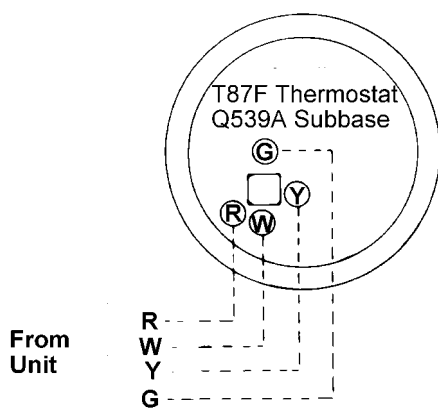

Figure 6
Typical Thermostat and Unit 24 V Wiring Hookup

CAUTION
To prevent improper and dangerous operation due to wiring errors, label all wires prior to disconnection when servicing controls. Verify proper operation after servicing.

VII. Circulating Air and Filters

Airflow Conversion

Units can easily be converted from horizontal to vertical airflow delivery.

Units will ship from the factory ready for horizontal airflow. If conversion to vertical airflow is necessary, proceed as follows:

IMPORTANT: Be sure to save the flue hood assembly (cardboard box) which is shipped in the return air compartment of the unit.

- Remove panels from the bottom of the unit, saving the mounting screws.
- Remove insulation from outside of supply duct cover. No insulation should face outside.
- Relocate the panels on to the side of the unit, securing with the screws removed earlier.
- The unit will deliver the same amount of air whether the airflow is vertical or horizontal. For details, see the fan tables on Pages 2 - 5.

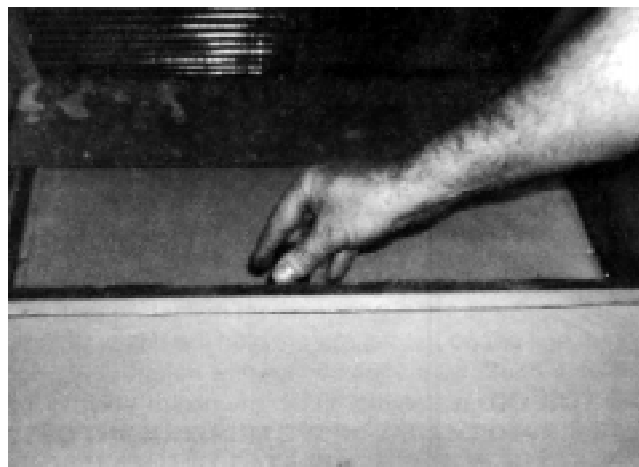

Figure 7
Airflow Conversion

Ductwork

CAUTION
To avoid possible fire, the cardboard shipping support (located behind the supply panel) must be removed before operation.

IMPORTANT: Be sure to save the flue hood assembly which is shipped in a cardboard box in the return air compartment of the unit.

Typical Wiring (Ground Level)

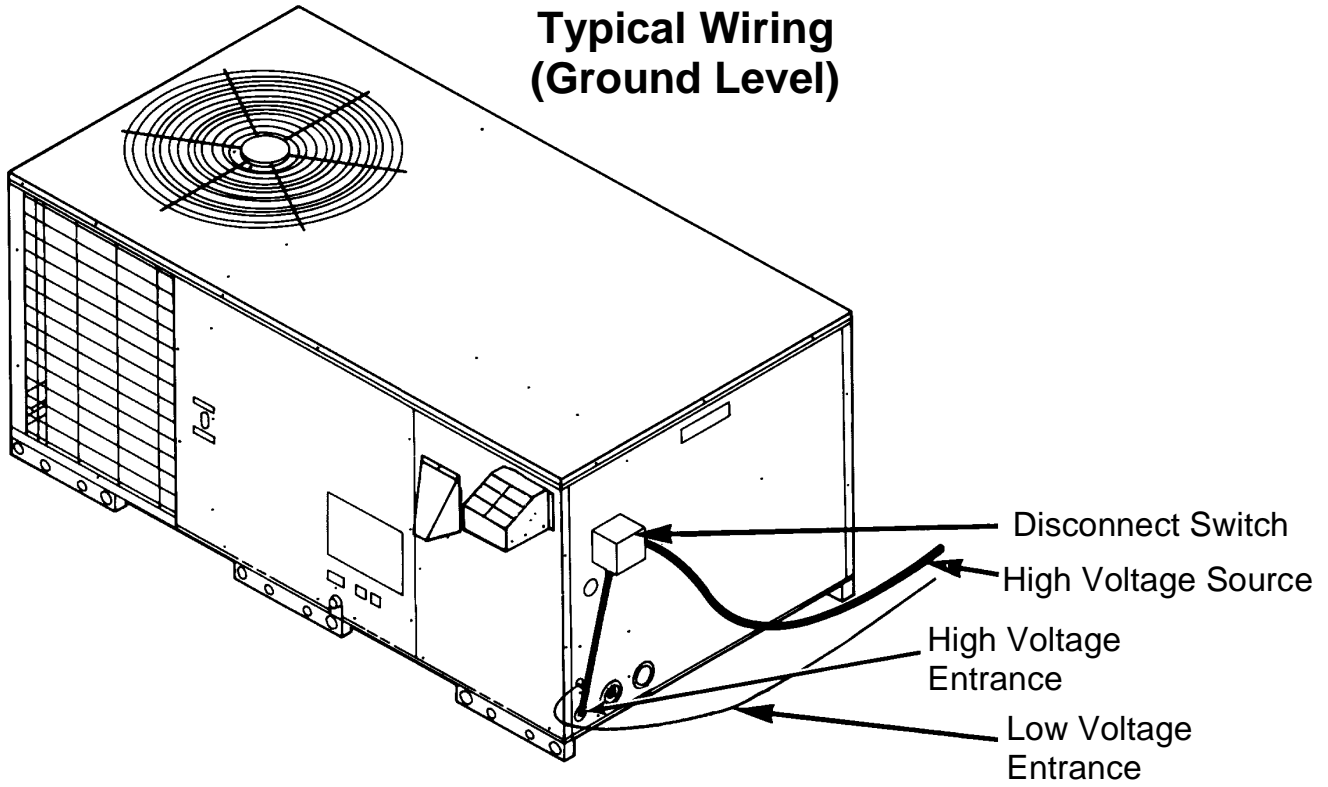

Typical Wiring (Rooftop)

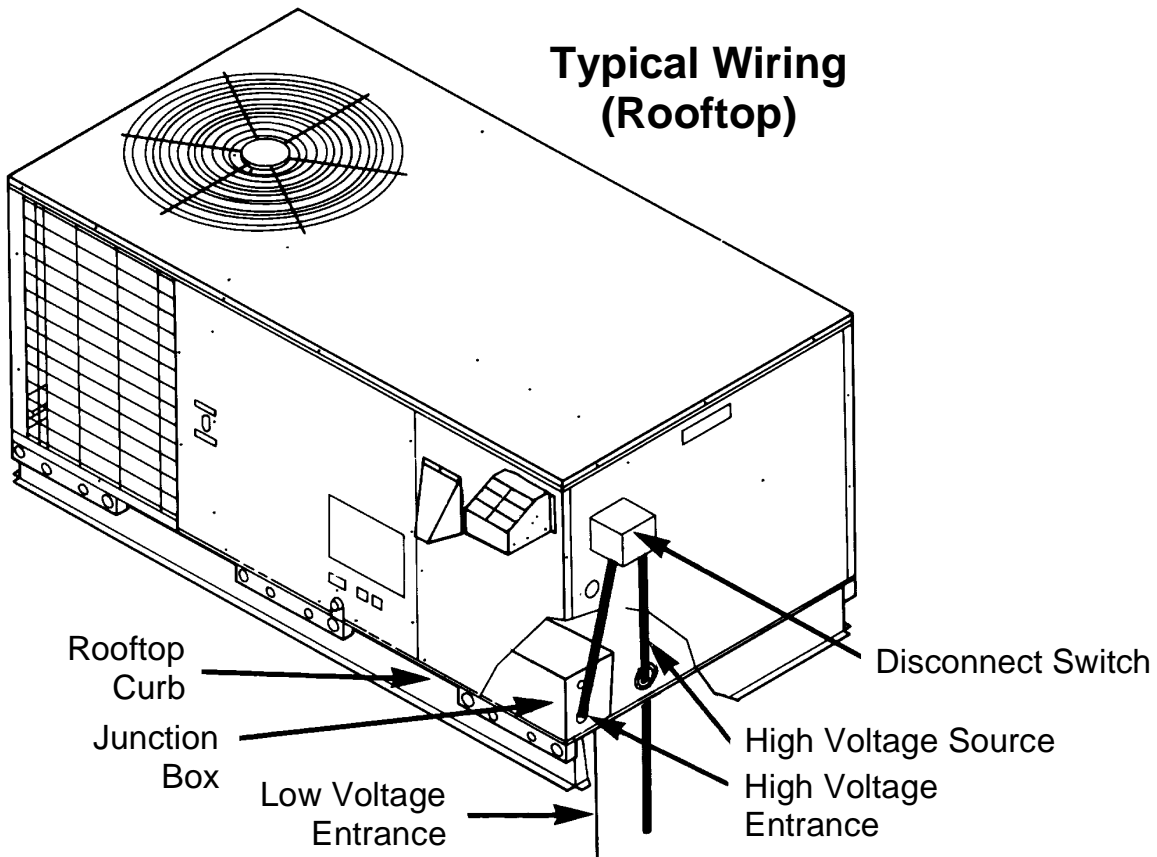

Figure 8
Typical Electrical Wiring

Duct systems and register sizes must be properly designed for the C.F.M. and external static pressure rating of the unit. Ductwork should be designed in accordance with the recommended methods of Air Conditioning Contractors of America Manual D (Residential) or Manual Q (Commercial). All ductwork exposed to the outdoors must include a weatherproof barrier and adequate insulation.

A duct system should be installed in accordance with Standards of the National Board of Fire Underwriters for the Installation of Air Conditioning, Warm Air Heating and Ventilating Systems, pamphlets No. 90A and 90B.

The warm air supply duct from the unit through a wall fabricated of combustible material may be installed without clearance. However, minimum clearances for the unit must be observed as shown in Section III.

It is recommended that the outlet duct be provided with an access panel. This access should be large enough to inspect the air chamber downstream from the heat exchanger for any smoke or combustion gas leaks. A cover should be tightly attached to prevent air leaks.

For horizontal airflow, duct flange dimensions on the unit are shown in Section III.

For vertical airflow, the ductwork should be attached to the roof curb prior to installing the unit. Ductwork dimensions are shown in the Amana PRC roof curb installation manual.

If desired, supply and return duct connections to the unit may be made with flexible connections to reduce possible noise transmission.

Filters

WARNING

Never operate furnace without a filter installed as dust and lint will build up on internal parts resulting in loss of efficiency, equipment damage, and possible fire.

A return air filter is not supplied with this unit; however, there must be a means of filtering all of the return air. For your convenience, this unit contains a factory installed filter rack. If you choose to install the return air filter in the unit filter rack, use the appropriate Amana filter kit or a permanent filter that is properly sized as follows:

Model	Amana Kit #	Required Permanent Filter Size
PGC24, 30, or 36	PFK3A1 or PFK3A6	26" x 20" x 1"
PGC42, 48, 60 or PGB58	PFK5B1 or PFK5B6	32-5/8" x 22-3/8" x 1"

The Amana filter kit includes a permanent filter, door label, and installation instructions. PFK3A1 and PFK5B1 contain filter, label, and instructions for one unit. PFK3A6 and PFK5B6 contain filters, labels, and instructions for six units.

Important: If you will be using the Over/Under Transition Kit, (PDTR0U3A or PDTR0U5A) you cannot use the unit filter rack.

If you are using the Over/Under transition kit or are simply choosing not to use this filter rack, the filter(s) may be located in the return air duct(s) or return air filter grille(s). Filters installed external to the unit should be sized in accordance with their manufacturer recommendations. If you choose to use a throwaway filter it should be sized for a maximum face velocity of 300 feet per minute.

Important: The PGC 42 and 48 package units contain an evaporator drip pan installed on the return air side of the indoor coil.

If an economizer is to be installed on these units, the drip pan must be removed. The pan can be removed by cutting it away. It will not be needed when an economizer is installed.

If filters are to be installed on these units, they must be from filter kit PFK5B1 or PFK5B6. The filters in these kits are sized to fit with the drip pan in place.

Filter Installation

Important: When installing a filter, always make certain the air flow arrows on the filter point toward the indoor blower.

To install a filter in the filter rack, proceed as follows:

1. Disconnect power to the unit.
2. Locate the filter access door above the return air opening. See Figure 9.

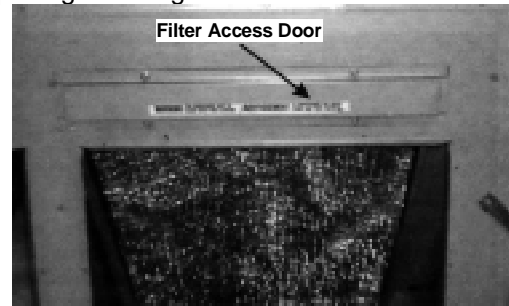

Figure 9
Filter Access Door

3. Remove the four 5/16" sheet metal screws and set the filter access door aside.
4. Insert the filter into the filter rack channels and lower into place. Make sure the filter slides completely to the bottom so no part of the filter remains outside the back panel.
5. Return the filter access door to its original position and secure it with the four sheet metal screws.
6. a. If you are using an Amana filter kit, affix the FILTER ACCESS label to the filter access door.
b. If you are NOT using an Amana filter kit, clearly mark the filter access door "FILTER ACCESS".
7. Reconnect the power.

NOTE: A clean permanent filter installed as described above will have a negligible effect on air flow.

VIII. Flue Vent

Flue Hood And Air Inlet Hood Installation

The flue hood and air inlet hood are packaged in a box which is located inside the return air compartment. They must be installed prior to operation of the unit. See Figure 10.

To install the flue hood cover:

1. Remove the flue hood from inside the box.
2. Slide the upper lip of the hood cover under the top edge of the unit.
3. Attach the flue hood with two sheet metal screws.

To install the air inlet hood:

1. Remove hood from inside box.
2. Attach hood by using three sheet metal screws.

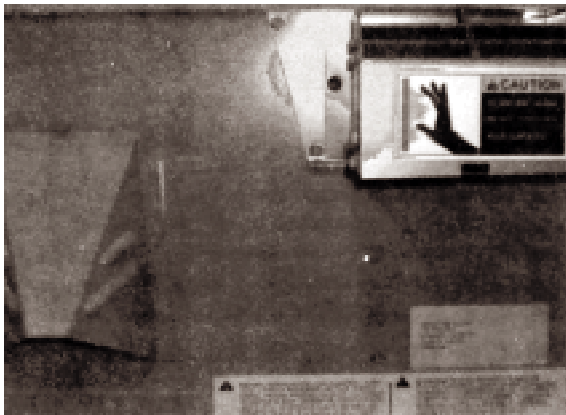

Figure 10
Air Inlet Hood and Flue Hood

Replacing a Indoor Furnace



WARNING

To prevent property damage, personal injury or death, do not vent this unit with any other appliance.

When an existing indoor furnace is removed from a venting system servicing other appliances, the venting system may be too large to properly vent the remaining attached appliances (water heater, etc.).

The following steps must be followed with each appliance remaining connected to the common venting system placed in operation, while the other appliances remaining connected to the common venting system are not in operation.

1. Seal any unused openings in the common venting system.
2. Visually inspect the venting system for proper size and horizontal pitch and determine there is no blockage or restriction, leakage, corrosion and other deficiencies which could cause an unsafe condition.

3. Insofar as is practical, close all building doors and windows and all doors between the space in which the appliances remaining connected to the common venting system are located and other spaces of the building. Turn on clothes dryers and any appliance not connected to the common venting system. Turn on any exhaust fans, such as the range hoods and bathroom exhausts, so they will operate at maximum speed. Do not operate a summer exhaust fan. Close fireplace dampers.
4. Follow the lighting instructions. Place the appliance being inspected in operation. Adjust the thermostat so appliance will operate continuously.
5. Test for spillage at the draft hood relief opening after five minutes of main burner operation. Use the flame of a match or candle.
6. After it has been determined that each appliance remaining connected to the common venting system properly vents when tested as outlined above, return doors, windows, exhaust fans, fireplace dampers, and any other gas-burning appliance to their previous conditions of use.
7. If improper venting is observed during any of the above tests, the common venting system must be corrected in accordance with the latest edition of the National Fuel Gas Code, (ANSI Z223.1).

If resizing any portion of the common venting system, use the appropriate table in Appendix G, in the latest edition of the National Fuel Gas Code, (ANSI Z223.1).

IX. Condensate Drain

Condensate Drain Connection

The evaporator condensate drain connection is 3/4" FPT. Clean out the inside of the drain connection to assure good condensate water runoff before connecting drain line. The drain line should have a trap on it to prevent debris, insects and dirt from being drawn into the return air system. Refer to Figure 11 for location. A 1" minimum head is recommended to allow draining against the negative pressure inside the unit.

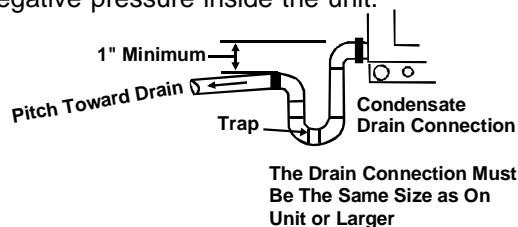

Figure 11
Typical Condensate Drain

NOTE: To avoid double trapping and an overflowing drain pan, soft plastic drain lines are not recommended.

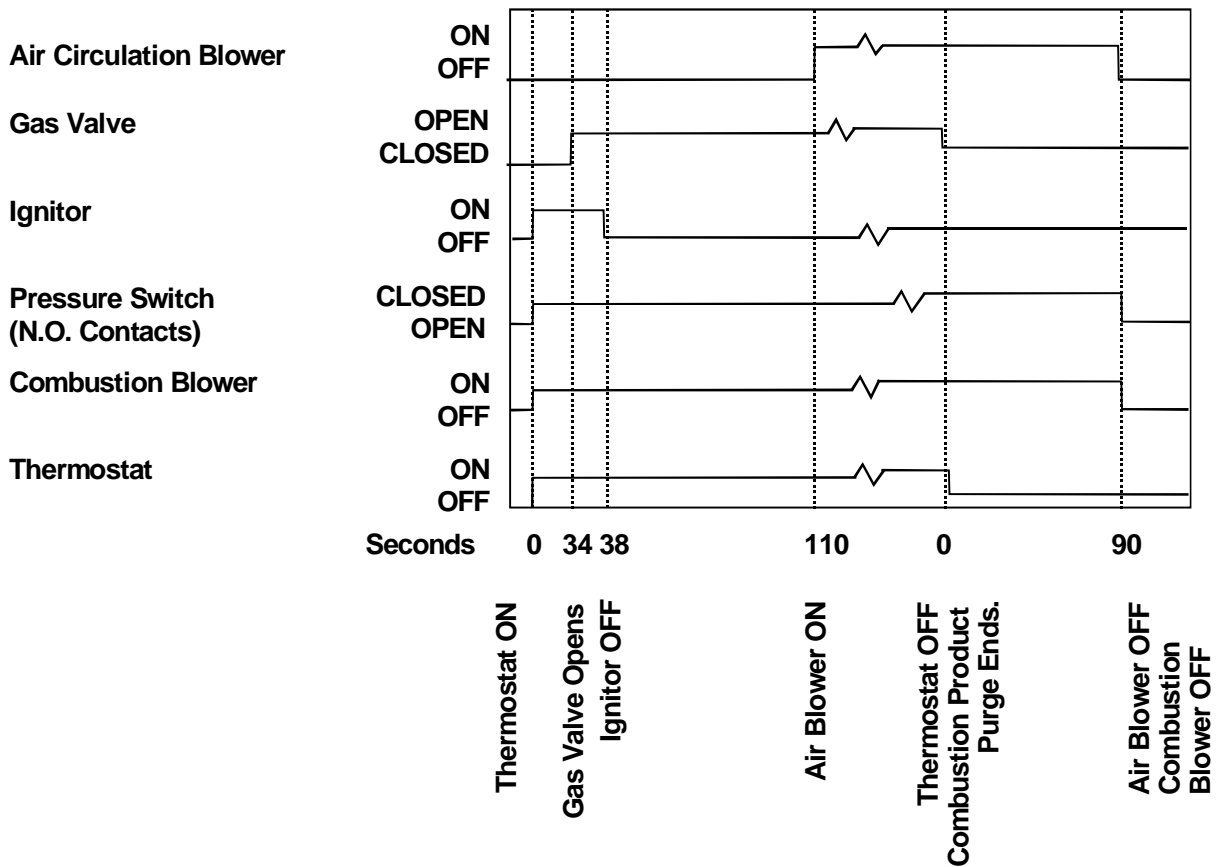

Figure 12
Timing Chart for Normal Robertshaw Operation (PGB & PGC)

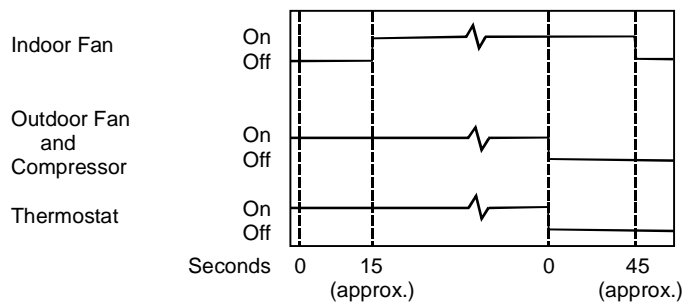

Figure 13A
PGB Timing Chart for Normal Cooling Operation

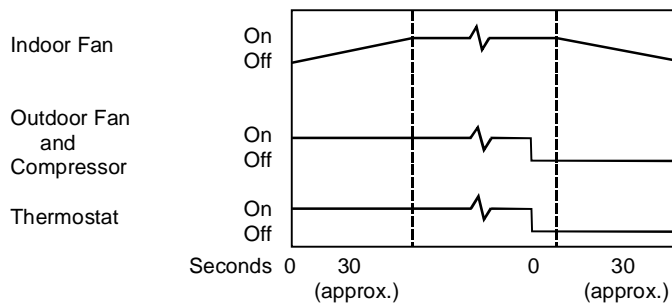

Figure 13B
PGC Timing Chart for Normal Cooling Operation

X. Heating Sequence of Operations PGB & PGC)

Normal Sequence of Operation - Heating

See Figure 12

1. Thermostat calls for heat. The combustion blower is immediately energized.
2. The pressure switch contacts transfer.
3. The ignitor is energized and allowed to preheat for 38 seconds.
4. The gas valve is energized delivering gas to the burners and starting combustion.
5. The control checks the signal from the flame sensor. Gas flow will continue only if a proper signal is present within seven seconds after the gas valve opens. As soon as flame is proven, the ignitor is de-energized.
6. The unit will continue to fire while the helical fan control heats up. The fan control will start the main circulating air blower approximately 75 seconds after the gas valve opens (this time may vary depending on the control setting).
7. The furnace will deliver heat to the conditioned space until the thermostat is satisfied.
8. The gas valve and combustion blower will be de-energized when the thermostat opens.
9. There is a 90 second delay (approximate) before the main air blower stops. This allows any additional heat in the heat exchanger to be transferred to the conditioned space.

XI. Cooling Sequence of Operations

PGB Normal Sequence of Operations - Cooling

See Figure 13A

1. Thermostat calls for cooling. The compressor and outdoor fan are energized.
2. Approximately 15 seconds later, the fan time delay relay closes. The indoor fan now begins operation.
3. The unit will deliver cooling to the conditioned space until the thermostat is satisfied.
4. The compressor and outdoor fan will be de-energized when the thermostat opens. It is normal for the scroll compressor to produce a short burping sound at this time as its internal pressures are equalized.
5. Refrigerant will continue to flow through the capillary tube (sizes 24 to 42) until the high and low side pressures are approximately equal. Refrigerant will continue to flow through the thermal expansion valve until the high and low side pressures are approximately 50 PSI apart.
6. The indoor fan continues to run for approximately 45 seconds after the thermostat is satisfied. This allows additional cooling from the indoor coil to be transferred to the conditioned space.

PGC Normal Sequence of Operations - Cooling

See Figure 13B

1. Thermostat calls for cooling. The compressor, indoor fan, and outdoor fan are energized.
2. Approximately 30 seconds later, the indoor fan ramps up to full speed.
3. The unit will deliver cooling to the conditioned space until the thermostat is satisfied.
4. The compressor and outdoor fan will be de-energized when the thermostat opens. It is normal for the scroll compressor to produce a short burping sound at this time as its internal pressures are equalized. (The PGC48 has a piston compressor. All other PGC and PGB have scroll compressors.)
5. Refrigerant will continue to flow through the capillary tube (sizes 24 to 42) until the high and low side pressures are approximately equal. For the PGC48, 60 and PGB58 refrigerant will continue to flow through the thermal expansion valve until the high and low side pressures are approximately 50 PSI apart.
6. The indoor fan continues to run for approximately 30 seconds after the thermostat is satisfied. This allows additional cooling from the indoor coil to be transferred to the conditioned space. Then, the indoor fan ramps down in 30 seconds to the OFF condition.

XII. Startup and Adjustment

Heating Startup

General Information

This furnace is equipped with an electronic ignition device which lights the burners. It also has a power vent blower to exhaust combustion products.

On new installations, or if a major part such as the gas valve, pressure switch or fan/limit control has been replaced, the operation of the furnace must be checked.

Check furnace operation as outlined in the following instructions. If any sparking, odors, or unusual noises are encountered, shut off electrical power and recheck for wiring errors, or obstructions in or near the blower motors. Various shipping materials must be removed before the indoor and outdoor fans can be operated.

Heat Anticipator Setting

The heat anticipator in the room thermostat must be correctly adjusted to obtain the proper number of heating cycles per hour and to prevent the room temperature from over-shooting the room thermostat setting. Heat anticipator must be set at 0.8 amps.

Roll-out Protection Control

If the flames from the burners are not properly drawn into the heat exchanger, a protection device will open, causing the gas valve to close. The protection device is located on the manifold assembly (Figure 14).



WARNING

To avoid the risk of fire or explosion, a qualified servicer must investigate the problem which caused the roll-out protection device to open before manually resetting the device.

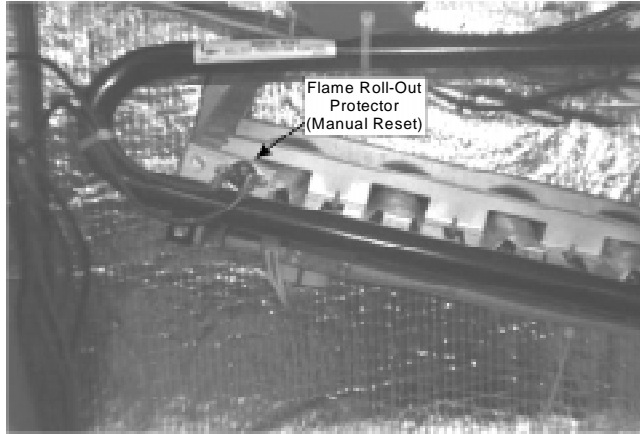

Figure 14
Rollout Protection
(Shown Without Heat Shield)

Secondary Limit Control

On the PGC and PGB series, a second limit control is placed on the blower scroll that will open if the blower should fail, causing elevated temperatures at the control. The reason for elevated temperatures at the control should be ascertained and repaired prior to resetting this manual reset control. The secondary limit control is located behind the front center panel on the blower scroll. (Figure 15).

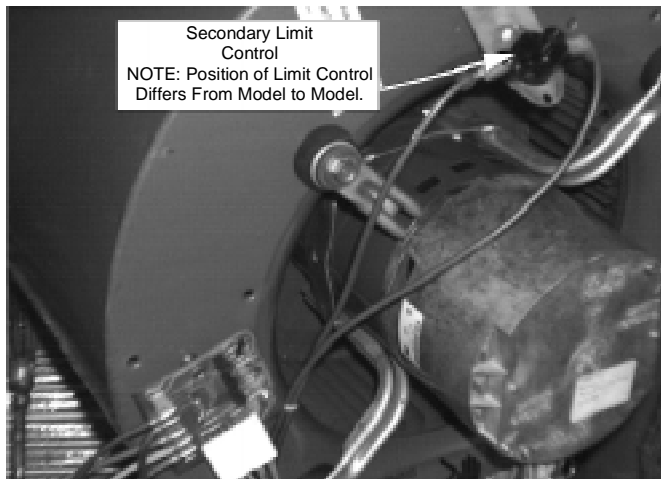

Figure 15
Position of Limit Control

Reset After Lock-out

Should ignition not be achieved after three tries for any reason, it will be necessary to reset the electronic ignition module. To reset, it is only necessary to turn the thermostat below room temperature for thirty seconds, and then reset it to the desired temperature. The furnace may also be reset after lockout by disengaging the electric disconnect switch to the furnace for thirty seconds.

Operating Instructions (Heating)

NOTE: Figure 16 illustrates the proper gas valve mounting location.

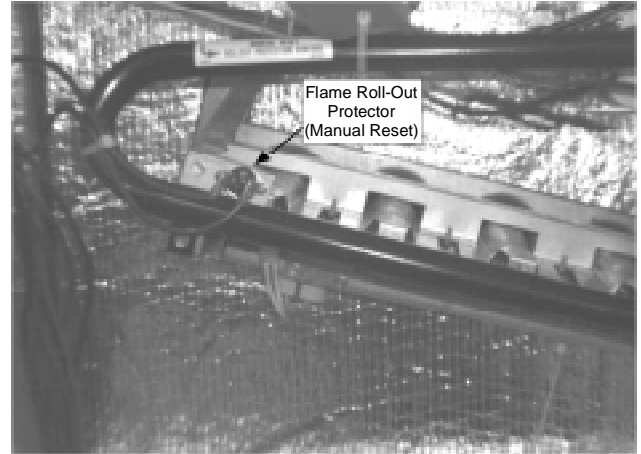

Figure 16
Gas Valve

1. Close the manual gas valve external to the furnace.
2. Turn off the electrical power supply to the furnace.
3. Set the room thermostat to its lowest possible setting.
4. Remove the right hand door on the front of the furnace by removing screws.
5. This furnace is equipped with an ignition device which automatically lights the burner. Do NOT try to light burner by any other method.
6. Turn the gas control valve knob to the OFF position. Do not force. (Figure 16).
7. Wait five minutes to clear out any gas.
8. Smell for gas, including near the ground. This is important because some types of gas are heavier than air. If you have waited five minutes and you do smell gas, immediately follow the instructions on Page 6 of this manual. If you have waited five minutes and you do NOT smell gas, turn the gas control valve knob to the ON position. (Figure 16).
9. Replace the door on the front of the furnace.
10. Open the manual gas valve external to the furnace.
11. Turn on the electrical power supply to the furnace.
12. Set the thermostat to desired setting.

NOTE: There is a one minute delay between thermostat energizing and burner firing.

Gas Input And Pressures

Gas supply pressure and manifold pressure with the burners operating must be as specified on the rating plate.

Checking Gas Pressure

Gas inlet pressure should be checked and adjusted in accordance to the type of fuel being consumed.

With Power And Gas Off:

1. Connect a water manometer or adequate gauge to the manifold gas pressure tap of the gas valve.

As an alternative method, inlet gas pressure can also be measured by removing the cap from the dripleg and installing a predrilled cap with a hose fitting. (See Figure 17).

With Power And Gas On:

2. Put furnace into heating cycle and turn on all other gas consuming appliances.

INLET GAS PRESSURE	
Natural	Min. 5.0" W.C., Max. 10.0" W.C.
Propane	Min. 11.0" W.C., Max. 14.0" W.C.

Inlet Gas Pressure Must Not Exceed the Maximum Values shown in Table Above.

If operating pressures differ from above, make necessary pressure regulator adjustments, check piping size, etc., and/or consult with local utility.

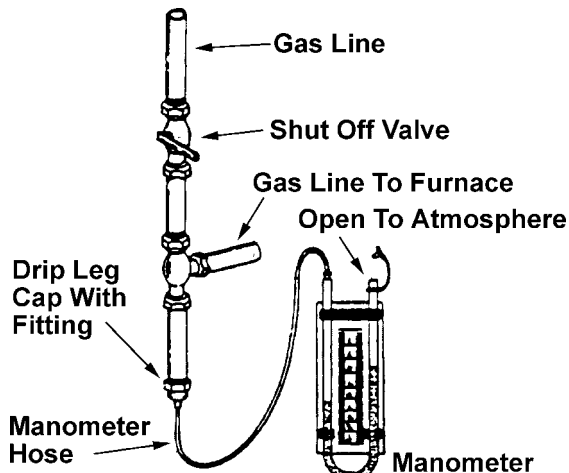

Figure 17
Measuring Inlet Gas Pressure
Alternate Method

Check The Manifold Pressure

A tapped opening is provided in the gas valve to facilitate measurement of the manifold pressure. A U Tube manometer having a scale range from 0 to 12 inches of water should be used for this measurement. The manifold pressure must be measured with the burners operating.

To adjust the pressure regulator, remove the adjustment screw or cover on the gas valve. Turn out (counterclockwise) to decrease pressure, turn in (clockwise) to increase pressure. Only small variations in gas flow should be made by means of the pressure regulator adjustment. In no case should the final manifold pressure vary more than plus or minus 0.3 inches water column from the specified pressure. Any major changes in flow should be made by changing the size of the burner orifices.

Check The Gas Input (Natural Gas Only)

NOTE: On outdoor equipment, the gas input will vary with the temperature of the gas. Rated input will be obtained at approximately 10° F. With warmer ambient and gas temperatures, the input will decrease. **Example:** At 70° F the input will decrease 12%.

To measure the gas input using the gas meter proceed as follows:

1. Turn off gas supply to all other appliances except the furnace.
2. With the furnace operating, time the smallest dial on the meter for one complete revolution. If this is a 2 cubic foot dial, divide the seconds by 2; if it is a 1 cubic foot dial, use the seconds as is. This gives the seconds per cubic foot of gas being delivered to the furnace.
3. $INPUT = GAS\ HTG\ VALUE \times 3600 / SEC.\ PER\ CU-BIC\ FOOT$

Example: Natural gas with a heating value of 1000 BTU per cubic foot and 34 seconds per cubic foot as determined by Step 2, then:

$$Input = 1000 \times 3600 / 0.34 = 106,000 \text{ BTU per Hour.}$$

NOTE: BTU content of the gas should be obtained from the gas supplier. This measured input must not be greater than shown on the unit rating plate.

4. Relight all other appliances turned off in Step 1 above. Be sure all pilot burners are operating.

Check Main Burner Flame

Flames should be stable, soft and blue, (dust may cause orange tips but they must not be yellow). They should extend directly outward from the burner without curling, floating or lifting off.

Check Temperature Rise

Check the temperature rise through the unit by placing thermometers in supply and return air registers as close to the furnace as possible. Thermometers must not be able to see the furnace heat exchangers, or false readings could be obtained.

1. All registers must be open; all duct dampers must be in their final (fully or partially open) position and the unit operated for 15 minutes before taking readings.
2. The temperature rise must be within the range specified on the rating plate.

NOTE: Air temperature rise is the temperature difference between supply and return air.

With a properly designed system, the proper amount of temperature rise will normally be obtained when the unit is operated at rated input with the recommended blower speed.

If the correct amount of temperature rise is not obtained, it may be necessary to change the blower speed. A higher blower speed will lower the temperature rise. A slower blower speed will increase the temperature rise.

NOTE: Blower speed **MUST** be set to give the correct air temperature rise through the furnace as marked on the rating plate.

Important Note: If an installation uses a different blower speed for cooling than is used for heating, do not set the thermostat fan switch to ON (constant fan operation) during the heating season without first confirming the cooling fan speed will give a temperature rise within the limits listed on the unit nameplate. Temperature rises outside the limits listed could result in premature heat exchanger failure.

Checking External Static Pressure

The total external static pressure must be checked on this unit to determine if the airflow is correct.

Changing Blower Speeds (PGC Units)



WARNING

To avoid personal injury or death due to electric shock, remove electrical power from the unit before changing speed taps on the blower motor.

PGC-B models include a BPM (brushless permanent magnet) motor. Under identical conditions, it operates at a lower power consumption than most PSC motors. Within the allowable range of external static pressures, the BPM motor will automatically adjust its RPM to deliver the CFM listed in the blower performance table. As static pressure increases, the RPM, current draw, and operating sound level of the motor will also increase. External static pressures in excess of those listed on the nameplate may result in unsatisfactory operation, equipment damage, and/or loss of warranty coverage.

The PGC-B models also include a speed tap board located on the blower housing. The speed tap settings have been factory selected according to unit size and performance. Field select taps are provided on the speed tap board to assist the final installer. The ADJ. tap is factory set for normal (NORM) operation. Three LED's are provided on the speed tap board. These lights indicate to the servicer which mode of operation the motor is experiencing, that is Heating (W1), Fan Only (G) or Cooling (Y and G).

Refer to the wiring diagram on the unit to verify speed tap settings.

Changing Blower Speeds (PGB Units)



WARNING

To avoid personal injury or death due to electric shock, remove electrical power from the unit before changing speed taps on the blower motor.

A multi-speed motor is used in the furnace blower. It provides easy speed selection for both heating and cooling air flow. Section II shows the CFM and E.S.P. relationship for proper selection of heating and cooling speeds. Cooling speed should be set for about 400 CFM per ton cooling capacity.

Refer to the Wiring Diagram on the furnace to connect the proper wires to the correct motor leads. All unused motor leads must be taped or securely covered with wire nuts.

Check Limit And Fan Control

1. Check limit control (Figure 18) operation after 15 minutes of operation by blocking the return air grille(s).
 - a. After several minutes the main burners must go OFF. Blower will continue to run.
 - b. Remove air restrictions and main burners will re-light after a cool down period of a few minutes.
2. Adjust the thermostat setting below room temperature.
 - a. Main burners must go off.
 - b. Circulating Air Blower should continue to run briefly until supply air temperature drops to approximately 90-100° F.

Fan and limit controls are preset at the factory. The control is set for the fan to go off at 90-100° F:

NOTE: If necessary, adjust fan ON/OFF settings to obtain satisfactory comfort level. The fan comes on at approximately 125° F.



WARNING

To avoid personal injury, property damage, fire, or premature failure of the heat exchanger, do not adjust the limit control, which is set at the factory.

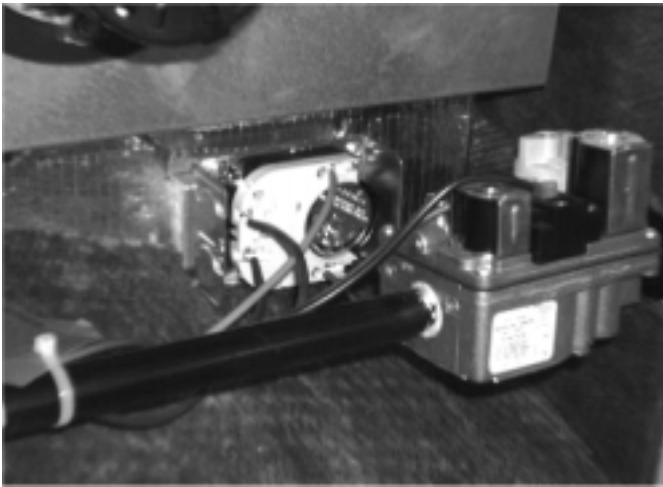

Figure 18
Fan and Limit Control

CAUTION

This unit should not be used as a “construction heater” during the finishing phases of construction on a new structure. This type of use may result in premature failure of the unit due to extremely low return air temperatures and exposure to very dirty atmospheres.

To Turn Off Unit

1. Set the thermostat to lowest setting.
2. Turn off the electrical power supply to the furnace.
3. Remove the right hand door on the front of the furnace by removing screws.
4. Turn the gas control valve knob to the OFF position. Do not force. See Figure 16.
5. Close manual gas shutoff valve external to the furnace.
6. Replace the door on the unit.
7. If cooling and/or air circulation will be desired, turn ON the electrical power.

Cooling Startup

Compressor Protection Devices

The PGC and PGB includes components which are designed to protect the compressor against abnormal operating conditions. These include the short cycle protector, external compressor protector (PGC24-42, 60 and PGB58 only), and high pressure cutout.

These controls reset automatically. Excessive cycling of the controls should be investigated before continuing operation.

(NOTE: The operation of the indoor blower will not be affected by any of the above compressor protection devices.)

WARNING

To avoid personal injury or death, always disconnect electrical power before inspecting or servicing the unit. All compressor protection devices reset automatically, energizing the contactor and outdoor fan.

Short Cycle Protector (Figure 19)

The short cycle protector is located in the blower compartment. Each time the compressor shuts off for any reason, the short cycle protector will open. It will take about 3 to 4 minutes before the short cycle protector will reset and allow compressor startup to occur.

All wiring connected to the short cycle protector is 24V. If the compressor cycles on the short cycle protector without cycling on any of the other compressor protection devices and before the call for cooling ends, common causes include:

- Interruption of the line voltage power.
- Improper thermostat installation, defective thermostat wiring, or defective thermostat.
- Rapid adjustments of the room thermostat.

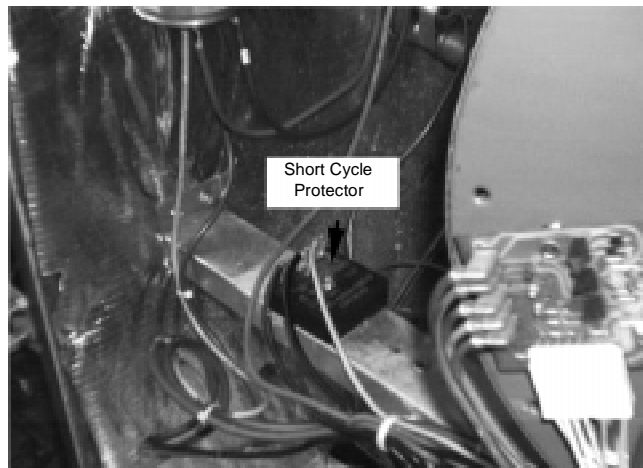

Figure 19
Short Cycle Protector Location

High Pressure Cutout (Figure 20)

An automatic reset high pressure control is located in the compressor discharge line. (See Figure 20) This control protects the unit from excessively high refrigerant pressure.

High pressures can result from:

- Inoperative outdoor fan motor.
- Outdoor coil restricted with debris.
- Recirculation of hot condenser air.
- Overcharge of refrigerant.

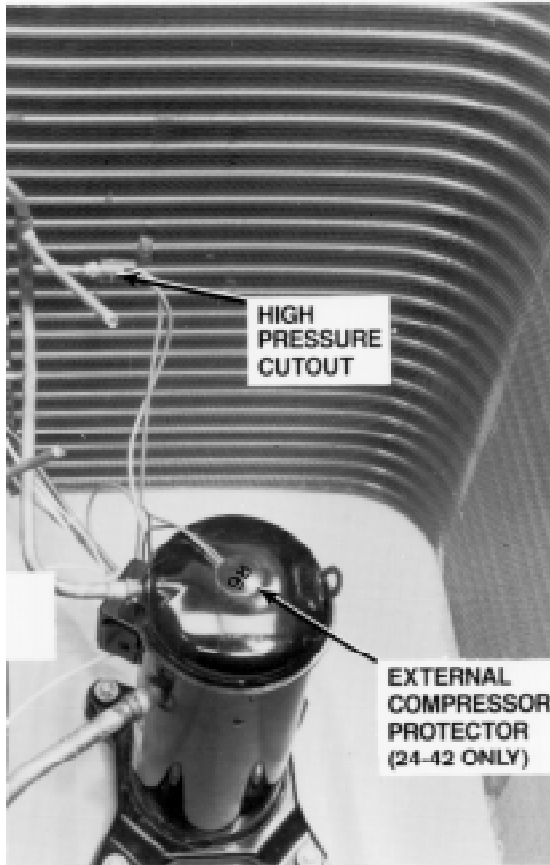

Figure 20
High Pressure Protection Devices

Scroll Compressors

PGC 24, 30, 36, 42, 60, and PGB58 units include scroll compressors. The installer and servicer should be aware of the following differences between scroll compressors and reciprocating compressors:

- These scroll compressors include a thermostat (external compressor protector) mounted to the top of the compressor. THIS PROTECTIVE DEVICE SHOULD NEVER BE BYPASSED FOR ANY PURPOSE.
- On a scroll compressor, due to its inherent ability to handle liquid refrigerant, a crankcase heater is not required.

CAUTION

To avoid severe personal injury or fire, refrigerant must be removed from both the low and the high pressure sides of the system before heat is applied.

- The scroll compressors use white oil which is compatible with 3GS. If the addition of oil in the field is required, 3GS may be used .

Important Note: Never close the compressor suction line to test its pumping efficiency. This will seriously damage the compressor and void its warranty.

- The compressor may run backwards (noisy operation) for 1 or 2 seconds at shutdown. This does not harm the compressor.
- These scroll compressors have copper plated steel suction tubes. If removal and reconnection becomes necessary, use silfos with minimum 5% silver or silver braze material with flux.
- Operating pressures and current draws may differ from standard reciprocating compressors. See Section XV for typical cooling performance data.

Reciprocating Compressor

The PGC48 includes a reciprocating compressor with a crankcase heater. See the caution for the PGC48 before starting cooling operation.

CAUTION

To avoid severe personal injury or fire, refrigerant must be removed from both the low and the high pressure sides of the system before heat is applied.

Operating Instructions (cooling)

CAUTION

On PGC48 Only: To avoid damage to the compressor, engage the electrical disconnect switch to the compressor unit four hours prior to operating air conditioner after the electrical disconnect is off for a prolonged period of time (during vacation, etc.). This time lapse allows the compressor crankcase to attain a proper operating temperature.

(NOTE: Mechanical cooling cannot be reliably provided at ambient temperatures below 50° F. If low ambient cooling will be required a downflow economizer is available. See Section XIV.)

1. Turn on the electrical power supply to the unit.
2. Place the room thermostat selector switch in the COOL position (or AUTO if available, and if automatic changeover from cooling to heating is desired).
3. Set the room thermostat to the desired temperature.

XIII. Maintenance



WARNING

To avoid personal injury or death due to electrical shock, disconnect electrical power before performing any maintenance.

Important Note: Touching the ignitor body with bare fingers, rough handling, or vibration could result in early ignitor failure. Only a qualified servicer should ever handle the ignitor.

Have the furnace checked at least once a year before the heating season begins, to be sure that the combustion air inlet and flue outlet hoods are not blocked by debris, which would prevent adequate combustion air and a properly operating vent system.

Replacing Or Cleaning Filter

A return air filter is not supplied with this unit; however, there must be a means of filtering all of the return air. The filter(s) may be located in the return air duct(s), return air filter grille(s) or in the filter rack in the unit. Consult with your installing dealer for the actual location of the return air filter(s) for your unit.

Dirty filters are the most common cause of inadequate heating or cooling performance. Filter inspection should be made at least every two months; more often if necessary because of local conditions and usage.

Dirty throwaway filters should be discarded and replaced with a new, clean filter. Dirty permanent filters should be washed with water, thoroughly dried and sprayed with a filter adhesive before being reinstalled. (Filter adhesives may be found at many hardware stores.) Permanent filters should last several years. However, should one become torn or uncleanable, it should be replaced.

If the installation has the return air filter located in the unit filter rack and it must be replaced, use the appropriate Amana filter or a permanent filter that is properly sized as follows:

Model	Amana Part #	Required Permanent Filter Size
PGC24, 30, or 36	C4855623	26" X 20" X 1"
PGC42, 48, 60 or PGB58	C4855627	32-5/8" X 22-3/8" X 1"

When installing a new filter or reinstalling an old one, always make certain the air flow arrows on the filter point in the proper direction. If using the unit filter rack, the airflow arrows must point toward the indoor blower.

To inspect the filter in the filter rack, proceed as follows:

1. Disconnect power to the unit.
2. Locate the filter access door (Figure 9) and remove the four sheet metal screws.
3. Pull out the filter and inspect. Clean or change as necessary.
4. Insert the filter into the filter rack channels and lower into place. Make sure the filter slides completely to the bottom so no part of the filter is left outside the back panel.
5. Return the filter access door to its original position and secure it with the four sheet metal screws.
6. Reconnect the power.

Maintaining Cabinet Finish

Use a fine grade automotive wax on the cabinet finish to maintain the original high luster. This is especially important in areas with high ultraviolet radiation.

Clean Outside Coil (Qualified Servicer Only)

The coil with the outside air flowing over it should be inspected annually and cleaned as frequently as necessary to keep the finned areas free of lint, hair and debris.

Blower Motor

The air circulating blower motor bearings are permanently lubricated.



Figure 21

Blower Motor and Housing

(NOTE: Brushless Permanent Magnet (BPM) blower motors are permanently lubricated and do not have oil ports. Oil cannot be added to these motors.)

Induced Draft Motor Lubrication

The induced draft motor is permanently sealed and does not require additional oiling.

Flame Sensor (Qualified Servicer Only)

Under some conditions, the fuel or combustion air supply can create a nearly invisible coating on the flame sensor. This coating acts as an insulator causing a drop in the flame sensing signal. If this occurs, a qualified servicer should carefully clean the flame sensor with emery cloth or steel wool. After cleaning, the microamp signal should be in the range listed in Table 1A.



Figure 22
Induced Draft Motor

Condenser Fan Motor Lubrication

The condenser fan motor bearings are permanently lubricated and do not require additional lubrication.

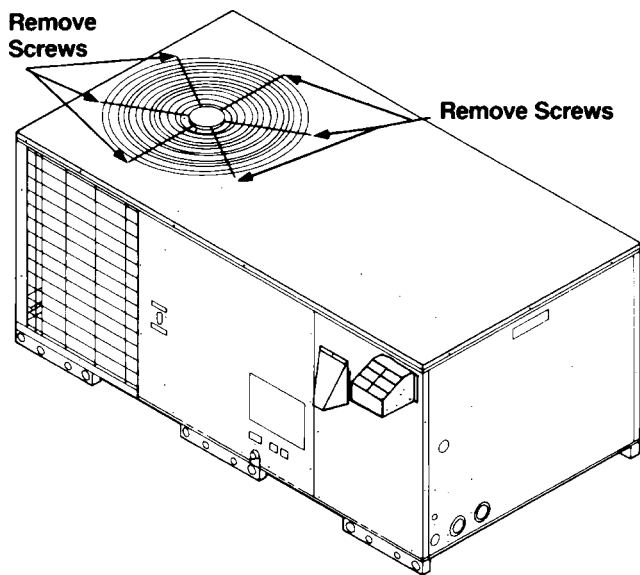

Figure 23
Removal of Fan Motor

Ignitor (Qualified Servicer Only)

If the ignitor and the surrounding air are at about 70° F and the ignitor wires are not connected to any other electrical components, the resistance of the ignitor should not exceed 200 ohms. If it does, the ignitor should be replaced.

Compressor

The compressor motor is permanently lubricated and hermetically sealed. It does NOT require oiling.

Flue Passages

At the start of each heating season, inspect, and if necessary clean the furnace flue passages.

Cleaning Flue Passages (Qualified Servicer Only)

1. Shut off electric power and gas supply to the furnace.
2. Remove burner assembly and disconnect the gas line and remove the manifold brackets from the partition panel.
3. Remove the induced draft blower and the collector box from the partition panel.
4. Remove tube inserts and turbulators from heat exchanger.
5. The primary heat exchanger tubes can be cleaned using a round wire brush attached to a length of high grade stainless steel cable, such as drain cleanout cable. Attach a variable speed reversible drill to the other end of the spring cable. Slowly rotate the cable with the drill and insert it into one of the primary heat exchanger tubes. While reversing the drill, work the cable in and out several times to obtain sufficient cleaning. Repeat for each tube.
6. When all heat exchanger tubes have been cleaned, replace the parts in the reverse order in which they were removed.
7. To reduce the chances of repeated fouling of the heat exchanger, perform the steps listed in Startup and Adjustment, Section XII.

Burners



WARNING

To avoid personal injury or death due to electrical shock, do not remove any internal compartment covers or attempt any adjustment. Contact a qualified servicer at once if an abnormal flame appearance should develop.

At least once a year, prior to or during the heating season, make a visual check of the burner flames.

NOTE: This will involve removing and reinstalling the right front door on the unit, which is held by several screws. If you are uncertain about your ability to do this, contact a qualified servicer.

If a strong wind is blowing, it may alter the airflow pattern within the furnace enough that an inspection of the burner flames is not possible.

The inspection of the burner flames must be performed with the heat shield in place. Only a qualified servicer should ever remove the heat shield from the manifold assembly.

For further information on the yearly inspection, consult the User Manual. It is recommended that a qualified servicer inspect and service the unit at least once each year.

Turn the furnace on at the thermostat. Wait a few minutes, since any dislodged dust will alter the normal flame appearance. Flames should be predominantly blue and directed into the tubes. They should not be yellow. They should extend directly outward from the burner ports without curling downward, floating or lifting off the ports.

XIV. Accessories and Functional Parts

Accessories

Additional Amana accessories can be purchased to fit specific application needs. Accessories can be ordered by description in Table 5. Each accessory includes its own separate instructions.

Accessory
Duct Transition Round
Duct Transition Over/Under
Rooftop Curb
Downflow Economizer
Fresh Air Intake
Barometric Relief Hood
50° F Compressor Lockout
Ambient Thermostat Kit
Emergency Heat Relay
Circuit Breaker Kit
Electric Heat Kit

**Table 5
Accessory List**

Pressure Drop of Transition Kit						
Model	CFM					
	700	900	1200	1400	1600	1800
PDTR0U3A	0.07	0.11	0.19	---	---	---
PDTR0U5A	---	---	---	0.06	0.08	0.10

**Table 6
Transition Kit Pressure Drop**

Replacement Parts

1. Refer to the description in Table 7 when ordering any of the listed functional parts. Be sure to provide the furnace model, manufacturing, and serial numbers with the order.

Gas Valve	BPM Blower Motor (PGC)
Heat Exchanger	Blower Motor (PGB)
Gas Orifice, Natural	Pressure Switch Hose
Evaporator Coil	Induced Draft Blower
Gas Orifice, Propane	Time Delay Relay
Transformer	Blower Relay (PGB)
Burner	Compressor
Ignitor	Pressure Switch
Combustion Relay	Contact
Flame Sensor	Flame Roll-Out Switch
Blower Wheel	Condenser Fan Blade
Ignition Control	High Pressure Cutout
Blower Housing	Condenser Fan Motor
Fan/Limit Switch	Compressor Time Delay
Speed Tap Board (PGC)	Condenser Coil

**Table 7
Functional Parts List**

2. Although only functional parts are shown in Table 7, all sheet metal parts, doors, etc. may be ordered by description or by referring to the Parts Manual.
3. Parts are available from your Amana distributor.

XV. Typical Cooling Performance Data

Outdoor Air Temp. at Condenser Inlet (Dry Bulb)	Indoor Air Temp. at Evap. Inlet (Wet Bulb)	PGC24				PGC30				PGC36			
		Indoor Air Temp.	Pressure @ Unit Gauge Fittings		Amps	Indoor Air Temp.	Pressure @ Unit Gauge Fittings		Amps	Indoor Air Temp.	Pressure @ Unit Gauge Fittings		Amps
		Difference Between Coil Inlet and Outlet	Low Side	High Side	Total to Unit	Difference Between Coil Inlet and Outlet	Low Side	High Side	Total to Unit	Difference Between Coil Inlet and Outlet	Low Side	High Side	Total to Unit
° F.	A	B	C	D	E	B	C	D	E	B	C	D	E
	° F.	° F.	PSIG	PSIG	Amps	° F.	PSIG	PSIG	Amps	° F.	PSIG	PSIG	Amps
115	77	7	92	325	12.8	7	89	320	15.8	7	88	351	19.3
	72	12	91	324	12.7	12	89	322	15.9	12	87	352	19.4
	67	17	91	324	12.7	17	88	322	15.8	17	87	352	19.3
	62	23	90	326	12.8	23	87	322	15.8	23	86	352	19.3
110	77	7	91	308	12.2	7	89	304	15.2	7	87	332	18.5
	72	12	90	304	12.1	12	88	303	15.1	12	87	332	18.5
	67	17	80	304	12.1	17	88	303	15.1	17	86	331	18.4
	62	23	89	304	12.1	23	87	302	15.1	23	85	329	18.4
105	77	7	90	288	11.7	7	88	285	14.5	7	86	311	17.6
	72	12	90	286	11.6	12	88	285	14.5	12	86	310	17.6
	67	18	89	286	11.6	18	87	283	14.5	18	85	312	17.6
	62	23	88	286	11.6	23	86	282	14.4	23	84	311	17.6
100	77	8	89	269	11.1	8	87	267	13.9	8	86	293	16.9
	72	12	89	269	11.1	12	87	267	13.9	12	85	293	16.9
	67	18	89	271	11.2	18	86	267	13.9	18	85	292	16.8
	62	23	88	271	11.2	23	85	267	13.9	23	84	290	16.7
95	77	8	89	255	10.7	8	87	251	13.4	8	85	275	16.2
	72	13	88	251	10.6	13	86	249	13.3	13	85	274	16.1
	67	18	88	252	10.7	18	86	249	13.3	18	84	274	16.1
	62	23	87	254	10.7	23	85	249	13.3	23	83	274	16.1
90	77	8	88	237	10.2	8	86	234	12.9	8	84	255	15.4
	72	13	88	236	10.2	13	86	232	12.8	13	84	255	15.4
	67	18	87	234	10.2	18	86	231	12.8	18	83	256	15.4
	62	24	86	235	10.2	24	84	231	12.8	24	83	254	15.4
85	77	8	87	222	9.8	8	86	217	12.3	8	84	240	14.8
	72	13	87	221	9.8	13	85	217	12.4	13	83	238	14.8
	67	18	86	221	9.8	18	84	216	12.3	18	83	238	14.7
	62	24	86	220	9.8	24	83	216	12.3	24	82	239	14.8
80	77	8	87	203	9.3	8	85	202	11.9	8	83	224	14.3
	72	13	86	203	9.3	13	84	203	12.0	13	83	223	14.2
	67	18	86	205	9.4	18	84	202	11.9	18	82	221	14.2
	62	24	85	206	9.4	24	83	202	11.9	24	81	221	14.2
75	77	8	86	189	9.0	8	84	189	11.6	8	83	208	13.7
	72	13	86	189	9.0	13	84	189	11.6	13	82	207	13.7
	67	19	85	191	9.0	19	83	189	11.6	19	82	207	13.7
	62	24	85	190	9.0	24	82	187	11.6	24	81	206	13.6

A Columns - All data based on indoor dry bulb of 80° F and rated air flow. As indoor dry bulb temperature increases, a slight increase will occur in indoor air temperature differential between inlet and outlet. Low and high side pressures and power will not change.

B Columns - A properly operating unit should be within ±3° F of the typical (dry bulb) value shown.

C Columns - A properly operating unit should be within ±3 PSIG of the typical value shown.

D Columns - A properly operating unit should be within ±7 PSIG of the typical value shown.

E Columns - A properly operating unit should be within ±2 amps of the typical value shown.

Table 8A

Outdoor Air Temp. at Condenser Inlet (Dry Bulb)	Indoor Air Temp. at Evap. Inlet (Wet Bulb)	PGC42				PGC48				PGC60 and PGB58			
		Indoor Air Temp.	Pressure @ Unit Gauge Fittings		Amps	Indoor Air Temp.	Pressure @ Unit Gauge Fittings		Amps	Indoor Air Temp.	Pressure @ Unit Gauge Fittings		Amps
		Difference Between Coil Inlet and Outlet	Low Side	High Side	Total to Unit	Difference Between Coil Inlet and Outlet	Low Side	High Side	Total to Unit	Difference Between Coil Inlet and Outlet	Low Side	High Side	Total to Unit
° F.	A	B	C	D	E	B	C	D	E	B	C	D	E
	° F.	° F.	PSIG	PSIG	Amps	° F.	PSIG	PSIG	Amps	° F.	PSIG	PSIG	Amps
115	77	7	86	332	23.1	8	88	327	23.8	9	83	343	34.9
	72	12	85	331	23.1	13	88	327	23.8	15	83	342	34.8
	67	18	85	332	23.1	18	88	327	23.8	21	82	342	34.7
	62	23	84	332	23.2	24	87	326	23.7	26	81	341	34.6
110	77	8	85	313	22.2	8	88	308	23.2	10	82	323	33.3
	72	13	85	313	22.2	13	87	308	23.2	15	82	322	33.2
	67	18	84	312	22.1	18	87	308	23.1	21	81	322	33.2
105	62	23	83	311	22.1	24	86	307	23.1	27	80	321	33.1
	77	8	84	294	21.3	8	87	291	22.5	10	82	303	31.8
	72	13	84	293	21.2	13	86	290	22.5	15	81	303	31.8
	67	18	83	294	21.3	18	86	290	22.5	21	80	303	31.8
100	62	23	82	293	21.2	24	85	290	22.4	27	80	302	31.7
	77	8	84	277	20.4	8	86	274	21.9	10	81	285	30.5
	72	13	83	276	20.4	13	86	273	21.9	15	80	285	30.4
	67	18	83	275	20.4	19	85	273	21.8	21	80	285	30.5
95	62	24	82	274	20.3	24	84	272	21.8	27	79	284	30.4
	77	8	83	259	19.6	8	85	256	21.3	10	80	268	29.2
	72	13	82	258	19.6	13	85	257	21.2	16	80	267	29.2
	67	18	82	257	19.5	19	84	256	21.2	22	79	267	29.2
90	62	24	81	256	19.5	25	84	255	21.1	28	78	266	29.1
	77	8	82	241	18.8	8	84	240	20.6	10	79	251	28.1
	72	13	82	241	18.8	14	84	240	20.6	16	79	250	28.0
	67	19	81	240	18.8	19	83	240	20.6	22	78	250	28.0
85	62	24	80	240	18.8	25	83	239	20.5	28	77	249	27.9
	77	8	82	226	18.1	9	84	225	20.0	11	79	234	27.0
	72	13	81	224	18.1	14	83	225	20.0	16	78	234	26.9
	67	19	81	225	18.1	19	83	224	20.0	22	78	233	26.9
80	62	24	80	223	18.0	25	82	224	19.9	28	77	232	26.8
	77	8	81	211	17.5	9	83	200	19.4	11	78	218	25.9
	72	13	81	210	17.5	14	82	210	19.4	16	78	218	25.9
	67	19	80	211	17.5	20	82	209	19.4	22	77	218	25.9
75	62	24	79	208	17.4	25	81	209	19.3	28	76	217	25.8
	77	9	80	196	16.9	9	82	196	18.8	11	78	204	25.0
	72	14	80	196	16.9	14	82	196	18.8	16	77	203	24.9
	67	19	79	194	16.8	20	81	195	18.8	22	76	203	24.9
	62	25	79	194	16.8	25	80	195	18.8	28	76	202	24.8

A Columns - All data based on indoor dry bulb of 80° F and rated air flow. As indoor dry bulb temperature increases, a slight increase will occur in indoor air temperature differential between inlet and outlet. Low and high side pressures and power will not change.

B Columns - A properly operating unit should be within ±3° F of the typical (dry bulb) value shown.

C Columns - A properly operating unit should be within ±3 PSIG of the typical value shown.

D Columns - A properly operating unit should be within ±7 PSIG of the typical value shown.

E Columns - A properly operating unit should be within ±2 amps of the typical value shown.

Table 8B

