



## OWNERS MANUAL

Model No.  
45-03641  
45-03642



## 250 LB. TOW BROADCAST SPREADER

CAUTION:  
Read Rules for  
Safe Operation  
and Instructions  
Carefully

- Safety
- Assembly
- Operation
- Maintenance
- Parts

**SpeedPart** *the fastest way to purchase parts* [www.speedpart.com](http://www.speedpart.com)

# RULES FOR SAFE OPERATION

Any power equipment can cause injury if operated improperly or if the user does not understand how to operate the equipment. Exercise caution at all times when operating equipment.

- Read the towing vehicle owners manual and towing vehicle safety rules. Know how to operate your tractor before using the broadcast spreader attachment.
- Read the chemical label instructions and cautions for handling and applying the chemicals purchased for spreading.
- Wear eye and hand protection when handling and when applying lawn or garden chemicals.
- Never operate tractor and spreader attachment without wearing substantial footwear, and do not allow anyone to ride or sit on spreader attachment frame.
- Never allow children to operate the tractor or spreader attachment, and do not allow adults to operate without proper instructions.
- Always begin with the transmission in first (low) gear and with the engine at low speed, and gradually increase speed as conditions permit.
- When towing broadcast spreader do not drive too close to a creek or ditch and be alert for holes and other hazards which could cause you to loose control of the broadcast spreader and tractor.
- Before operating vehicle on any grade (hill) refer to the safety rules in the vehicle owner's manual concerning safe operation on slopes. **Stay off steep slopes!**
- Follow maintenance and lubrication instructions as outlined in this manual.

 **LOOK FOR THIS SYMBOL TO POINT OUT IMPORTANT SAFETY PRECAUTIONS. IT MEANS — ATTENTION! BECOME ALERT! YOUR SAFETY IS INVOLVED.**

## CARTON CONTENTS (Loose Parts in Carton)

1. Hopper Assembly
  2. Braces (6)
  3. Flow Control Rod
  4. Flow Control Mounting Tube
  5. Wheels (2)
  6. Hitch Extension Bracket
  7. Hitch Bracket
  8. Hitch Tube
  9. Flow Control Mount Bracket
  10. Flow Control Arm
  11. Hopper Cover
  12. Screen
- Hardware Package (see page 3)

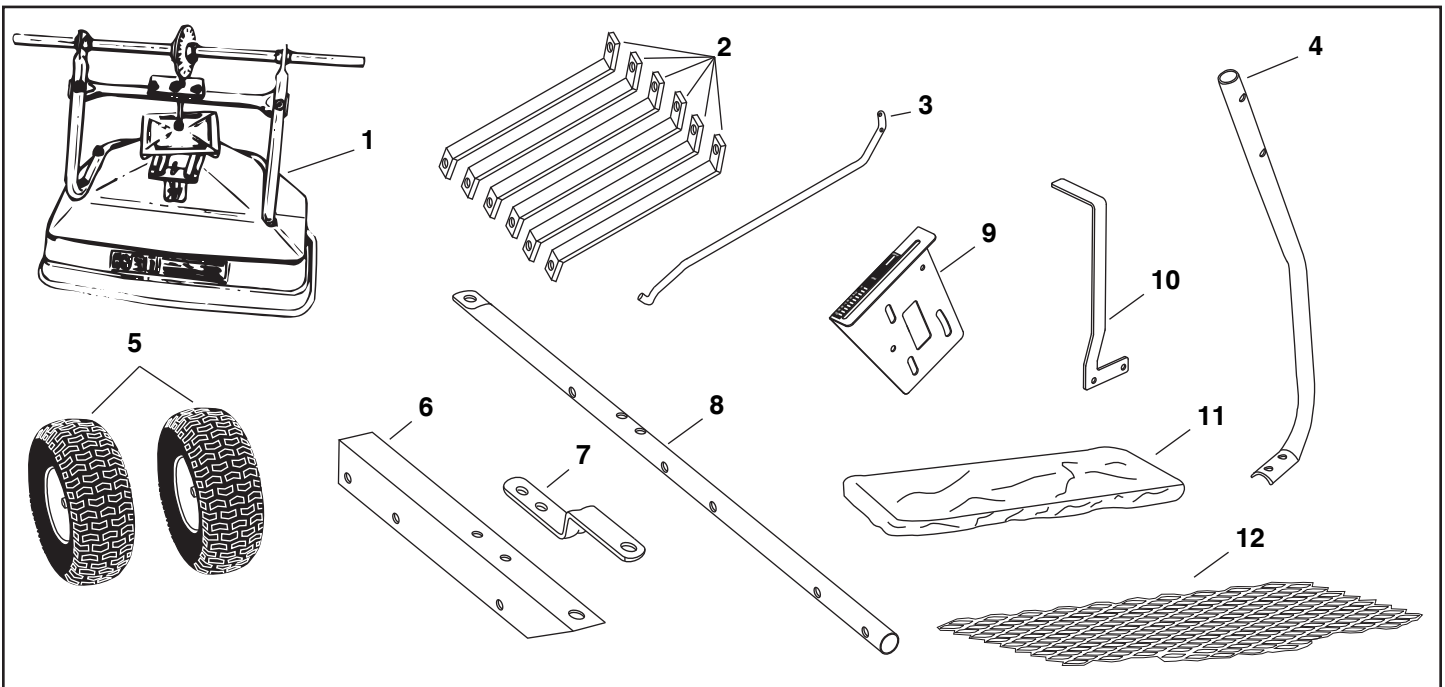

**SHOWN FULL SIZE**

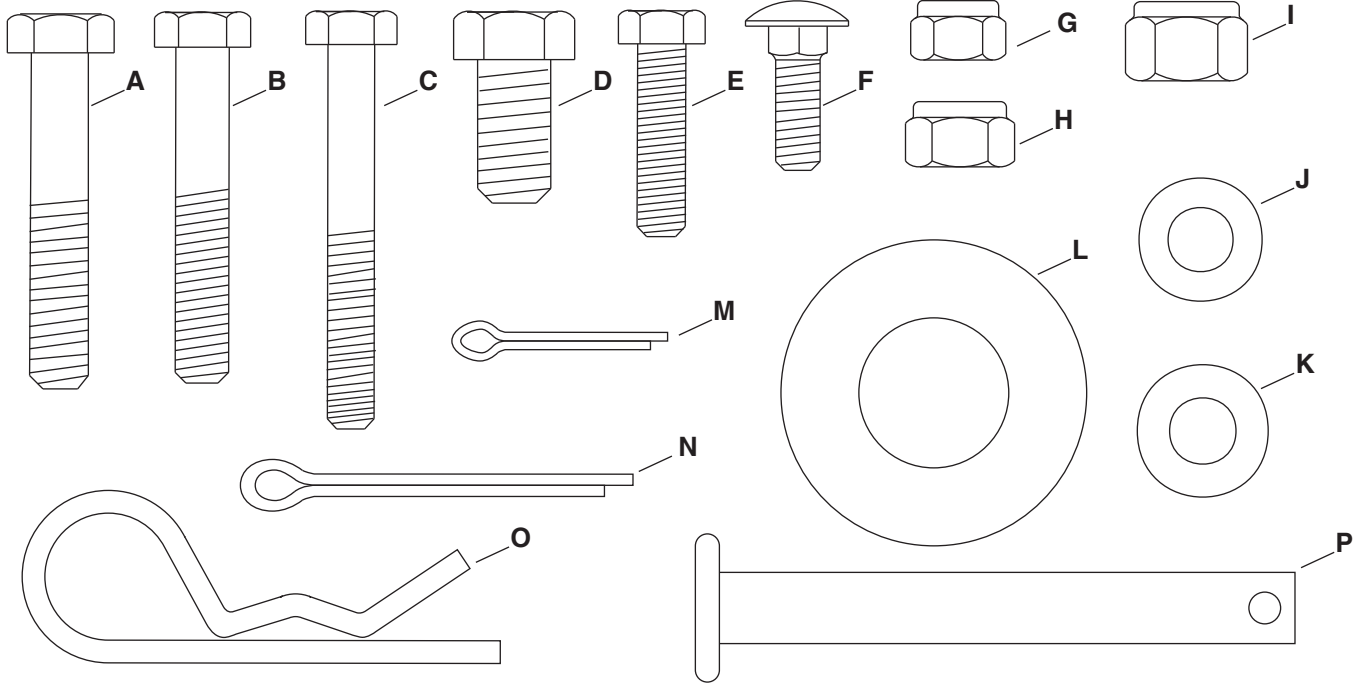

**NOT SHOWN FULL SIZE**

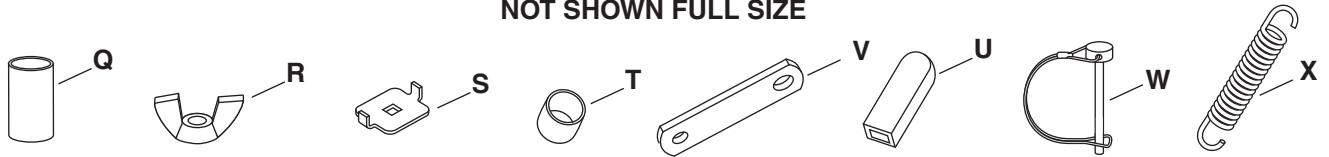

KEY	QTY.	DESCRIPTION	KEY	QTY.	DESCRIPTION
A	4	Hex Bolt, 5/16" x 1-3/4"	M	1	Cotter Pin, 3/32" x 3/4"
B	5	Hex Bolt, 1/4" x 1-3/4"	N	2	Cotter Pin, 1/8 x 1-1/2"
C	1	Hex Bolt, 1/4" x 2"	O	1	Hair Cotter Pin
D	2	Hex Bolt, 3/8" x 3/4"	P	1	Hitch Pin
E	2	Hex Bolt, 1/4" x 1"	Q	2	Spacers
F	1	Carriage Bolt, 1/4" x 3/4"	R	1	Nylon Wing Nut
G	8	Nylock Hex Nut, 1/4"	S	1	Adjustable Stop
H	4	Nylock Hex Nut, 5/16"	T	1	Vinyl Cap
I	2	Nylock Hex Nut, 3/8"	U	1	Grip
J	4	Nylon Washer	V	1	Flow Control Link
K	7	Flat Washer, 5/16"	W	1	Drive Pin
L	4	Flat Washers, 3/4"	X	1	Spring

# ASSEMBLY INSTRUCTIONS

## TOOLS REQUIRED FOR ASSEMBLY

- (1) Pliers
- (2) 7/16" Wrenches
- (2) 1/2" Wrenches
- (2) 9/16" Wrenches

## REMOVAL OF PARTS FROM CARTON

Remove all parts and hardware packages from the carton. Lay out all parts and hardware and identify using the illustrations on pages 2 and 3.

## ASSEMBLY

1. Turn the spreader upside down as shown in figure 1.
2. Remove the lock nut from the middle bolt in the crossover tube and shaft support plate. Leave the bolt in place. See figure 1.
3. Assemble the hitch tube onto the middle bolt and secure it with the same lock nut you removed. **DO NOT TIGHTEN YET.** See figure 1.

**IMPORTANT:** The hitch tube must attach to the side of the crossover tube opposite the shaft support plate.

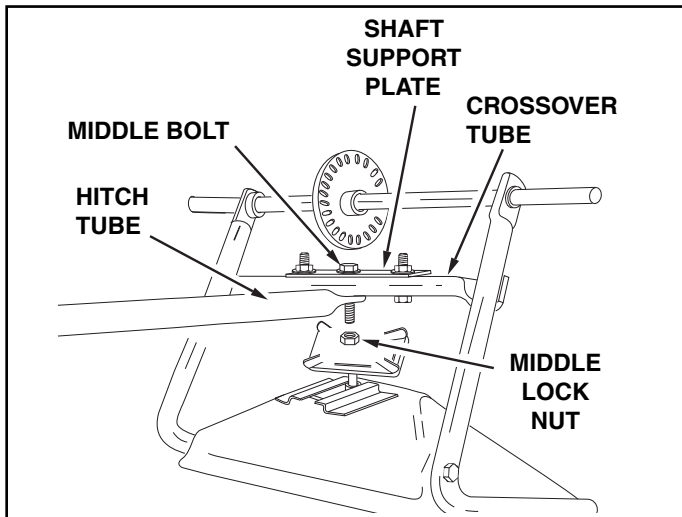

FIGURE 1

4. Stack the hitch braces into two sets of three, making sure the raised sides of the braces are facing the same direction. See figure 2.
5. Assemble the six hitch braces (three per side) to the inside of the hopper frame using a 1/4" x 1-3/4" hex bolt (B) and 1/4" nylock hex nut (G) on each side. **DO NOT TIGHTEN YET.** The hitch braces should be able to move freely. See figure 2.

6. Assemble the two **outer** hitch braces on each side to the hitch tube using a 1/4" x 2" hex bolt (C) and a 1/4" nylock hex nut (G). **DO NOT TIGHTEN YET.** Do not assemble the two inner hitch braces at this time. See figure 2.

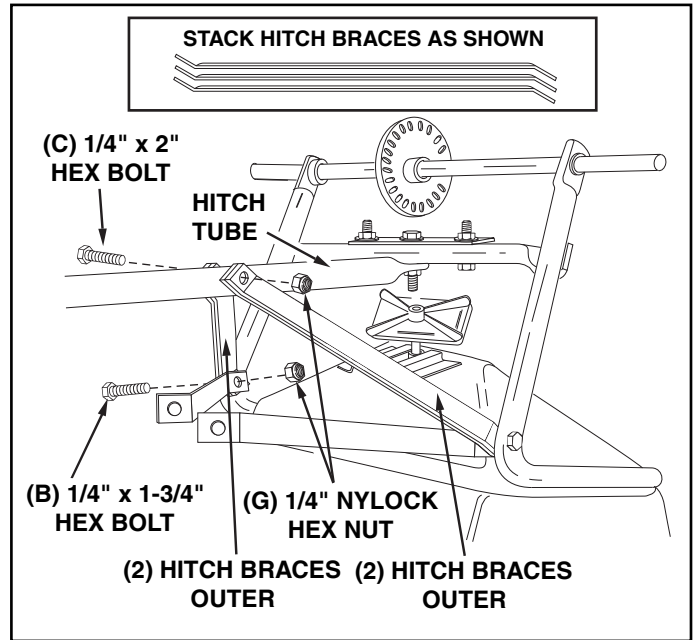

FIGURE 2

7. Assemble a spacer (Q), a 3/4" flat washer (L), a wheel (air valve facing out) and another 3/4" flat washer (L) onto the end of the axle that has only the **small hole**. See figure 3.
8. Install a 1/8" x 1-1/2" cotter pin (N) into the hole in the axle. See figure 3.

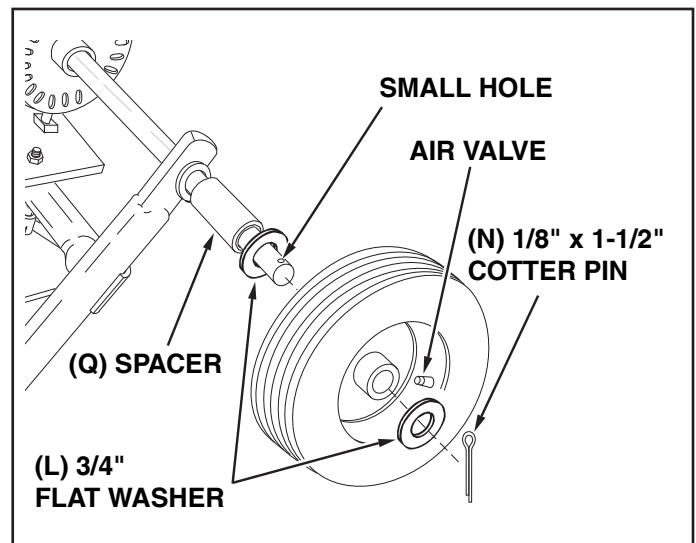

FIGURE 3

9. Assemble a spacer (Q), a 3/4" flat washer (L), a wheel (air valve facing out) and another 3/4" flat washer (L) onto the end of the axle that has both the **large and small holes**. See figure 4.
10. Install a 1/8" x 1-1/2" cotter pin (N) into the small hole in the end of the axle. See figure 4.
11. Open the bail on the drive pin (W) and install it through the wheel and the large hole in the axle. Close the bail to lock the pin in place. See figure 4.

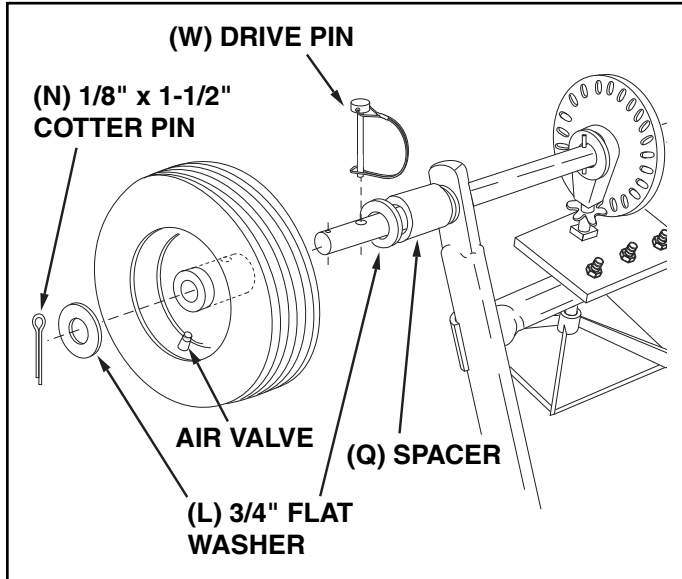

FIGURE 4

12. Turn the spreader upright on its wheels.
13. Assemble the flow control mounting tube to the hitch tube using two 5/16" x 1-3/4" hex bolts (A) and 5/16" nylock hex nuts (H). **DO NOT TIGHTEN YET**. See figure 5.
14. Assemble the vinyl cap (T) onto the flow control mounting tube. See figure 5.

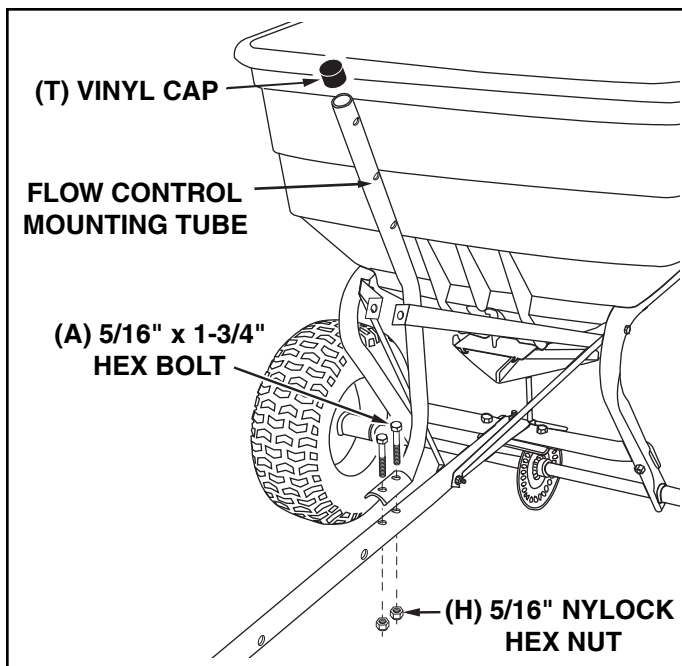

FIGURE 5

15. Assemble the two **inner** hitch braces to the flow control mounting tube using a 1/4" x 1-3/4" hex bolt (B) and a 1/4" nylock hex nut (G). **DO NOT TIGHTEN YET**. See figure 6.
16. **Tighten** all nuts and bolts assembled up to this point. **Do not collapse the tubes when tightening**.

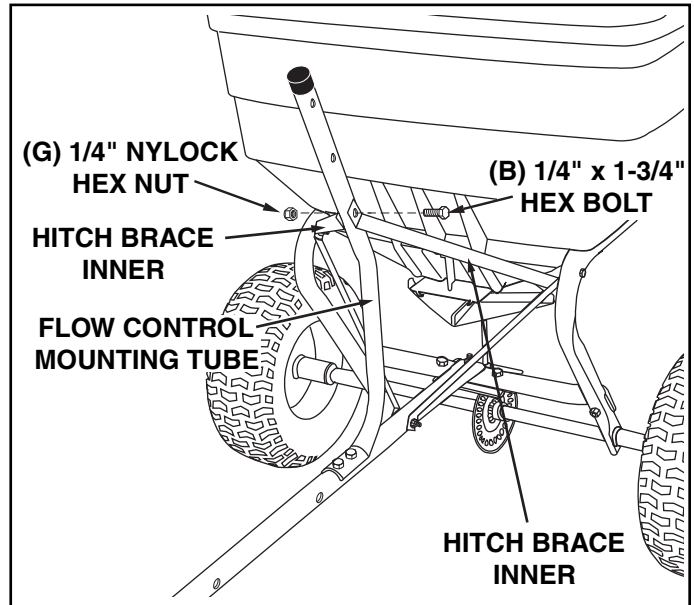

FIGURE 6

17. Assemble the flow control mounting bracket to the flow control mounting tube using two 5/16" x 1-3/4" hex bolts (A), four 5/16" flat washers (K) and two 5/16" nylock hex nuts (H). **DO NOT TIGHTEN YET**. See figure 7.

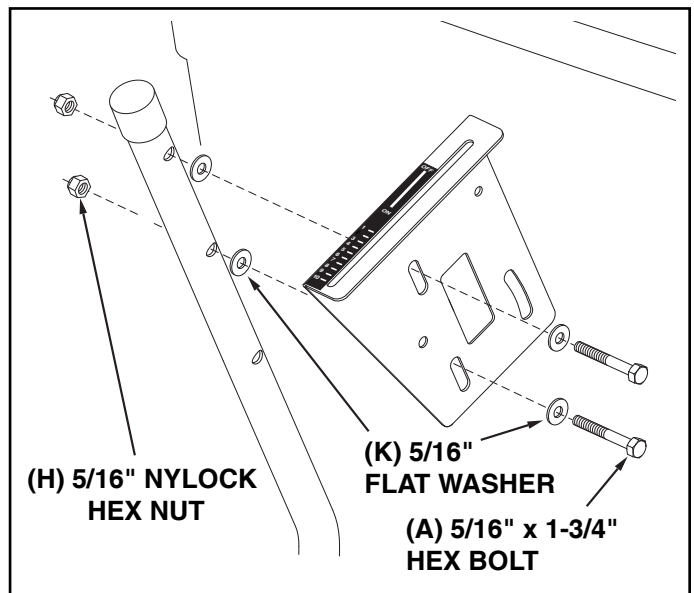

FIGURE 7

18. Assemble the vinyl grip (U) onto the flow control arm. See figure 8.
19. Insert the flow control arm down through the slot in the flow control bracket. Assemble the small hole of the flow control link (V) to the flow control arm using a 1/4" x 1" hex bolt (E), a nylon washer (J) and a 1/4" nylock hex nut (G) as shown in figure 8. **Tighten carefully.** The flow control link should be snug but should pivot with no more than slight resistance.

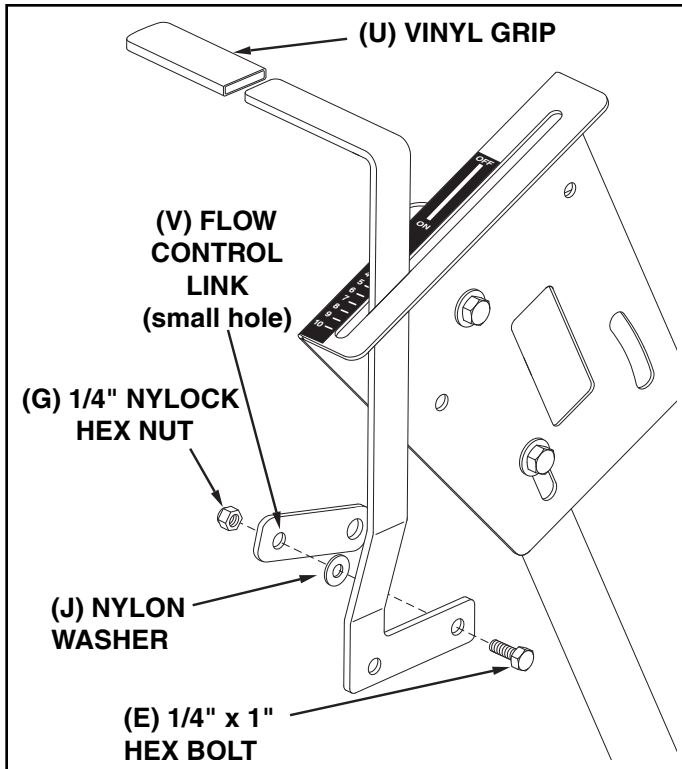

FIGURE 8

20. Assemble the flow control arm to the flow control mounting bracket using a 1/4" x 1" hex bolt (E), two nylon washers (J) and a 1/4" nylock hex nut (G). **Tighten carefully.** The flow control arm should be snug but should pivot with no more than slight resistance. See figure 9.

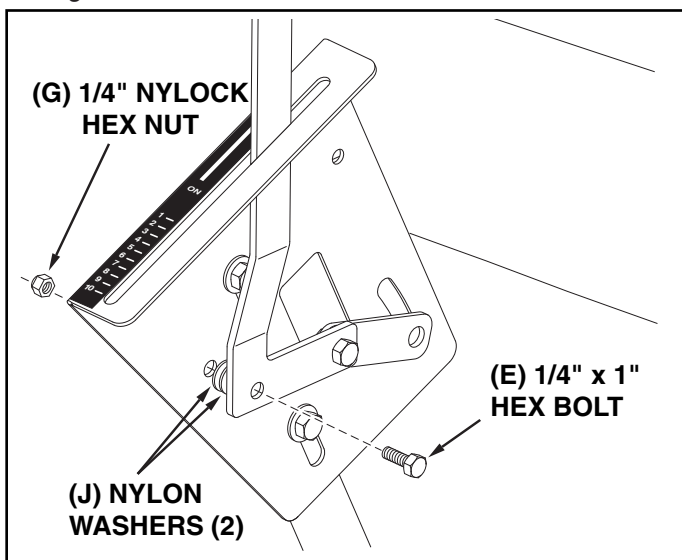

FIGURE 9

21. Hook the double bent end of the flow control rod through the hole in the slide gate bracket located near the bottom of the hopper. See figure 10.

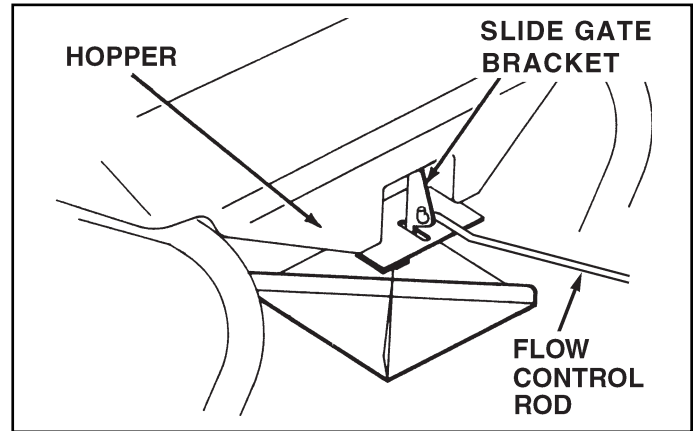

FIGURE 10

22. Place a 5/16" flat washer (K) onto the other end of the flow control rod. Insert the end of the rod through the curved slot in the flow control mounting bracket and through the hole in the flow control link. Secure with a 5/16" flat washer (K) and a 3/32" x 3/4" cotter pin (M). See figure 11.

**NOTE:** You can leave off the second washer if there is not enough room on the end of the rod.

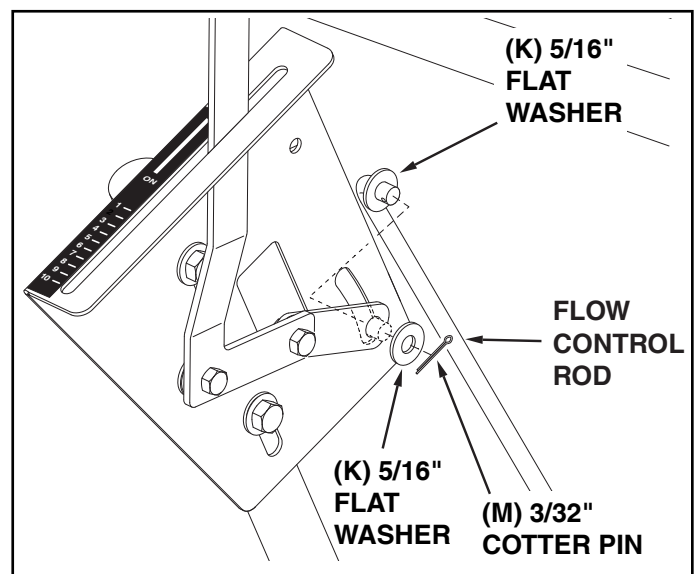

FIGURE 11



23. Place the adjustable stop (S) into the "ON" end of the slot in the top of the flow control mounting bracket. Secure with the 1/4" x 3/4" carriage bolt (F), a nylon washer (J), a 5/16" flat washer (K) and the nylon wing nut (R). See figure 12.

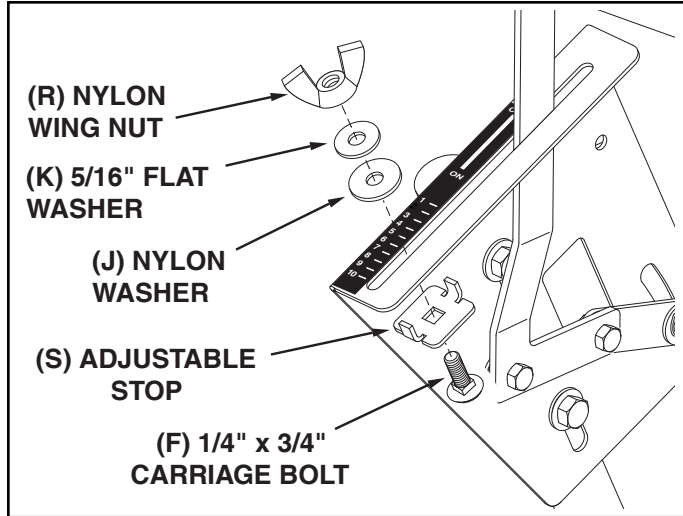

FIGURE 12

24. Slide the adjustable stop to the end of the slot. Move the flow control arm against the stop. Assemble the spring (X) to the flow control mounting bracket and then to the flow control rod. See figure 13.

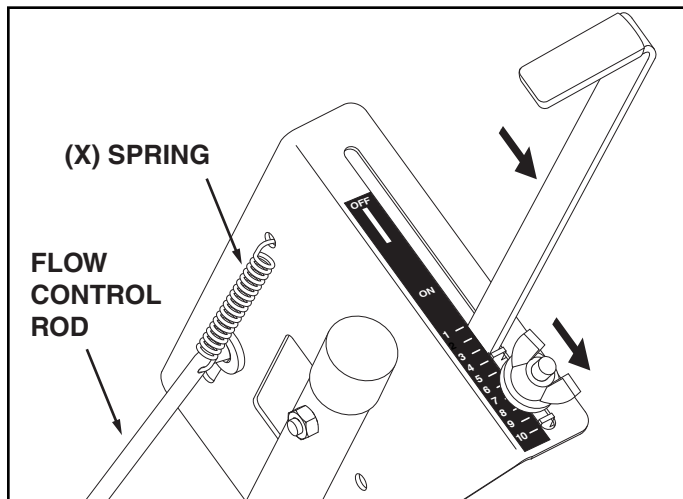

FIGURE 13

25. Position the flow control mounting bracket (figure 14).
- Push flow control arm to "OFF" position.
  - Slide flow control mounting bracket along tube until closure plate in bottom of hopper just closes.
  - Snug the 5/16" lock nuts just enough to hold flow control mounting bracket in place.
  - Set adjustable stop at "5". Pull flow control arm against stop. Verify that closure plate has opened about half way.
  - If closure plate does not open half way, adjust position of flow control mounting bracket until closure plate will open about half way at "5" and will still close when arm is locked in "OFF" position. **Tighten** the 5/16" lock nuts.

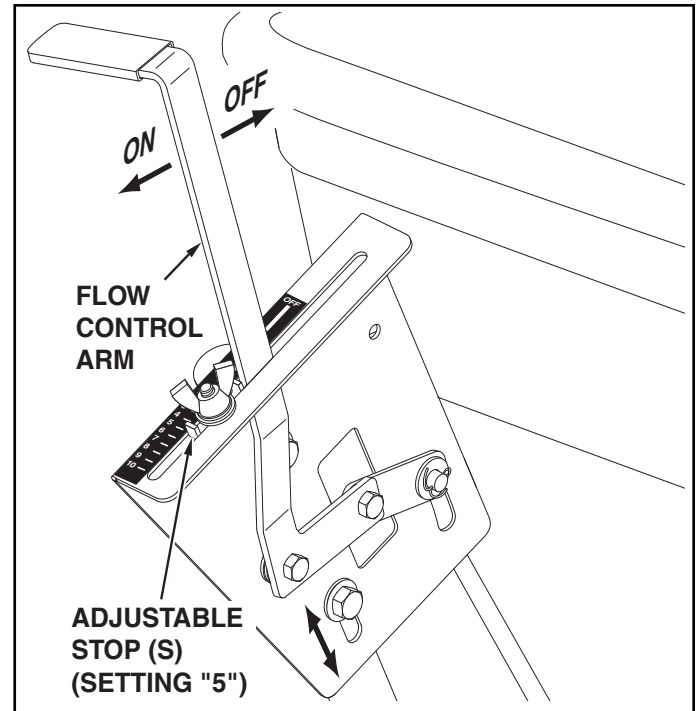

FIGURE 14

26. Place the screen down into the hopper, sliding the edge of the screen under one of the clips. Slightly bow the screen to slide the opposite side of the screen under the other clip. See figure 15.

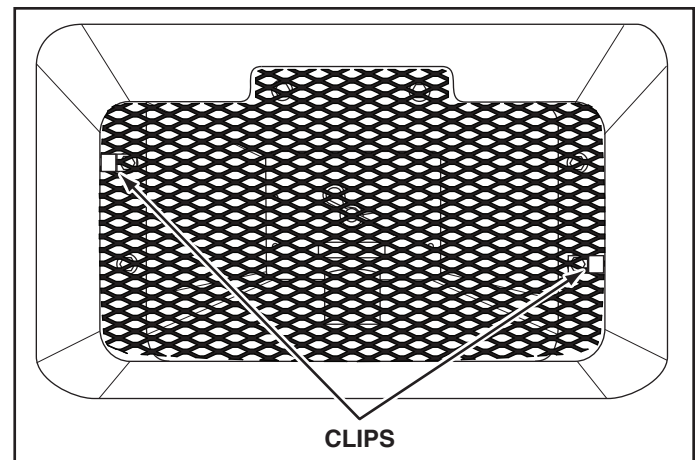

FIGURE 15

27. Assemble the hitch bracket to the hitch extension bracket using two 3/8" x 3/4" hex bolts (D) and 3/8" nylock hex nuts (I). Insert the bolts from the bottom. See figure 16.

28. Assemble the hitch pin (P) through the hitch bracket and the hitch extension bracket and secure with the hair cotter pin (O). See figure 16.

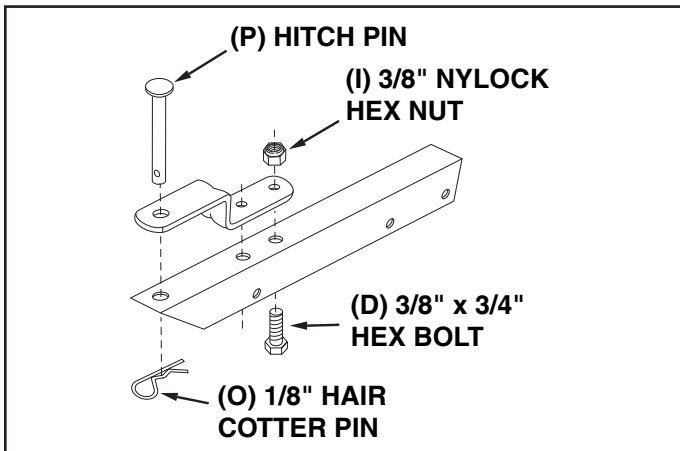

FIGURE 16

29. For most vehicles, assemble the hitch extension bracket to the holes in the hitch tube shown at the **top** of figure 17. Use two 1/4" x 1-3/4" hex bolts (B) and 1/4" nylock hex nuts (G) tightened only finger tight. Attach the spreader hitch to your vehicle hitch. Check for interference with the spreader directly behind and out to both sides of the vehicle. Lift the spreader at each position to make sure there is no interference with the spreader's flow control. If there is interference with the rear of the vehicle, assemble the hitch extension bracket as shown at the **bottom** of figure 17.

30. **Tighten** the bolts and nuts when finished.

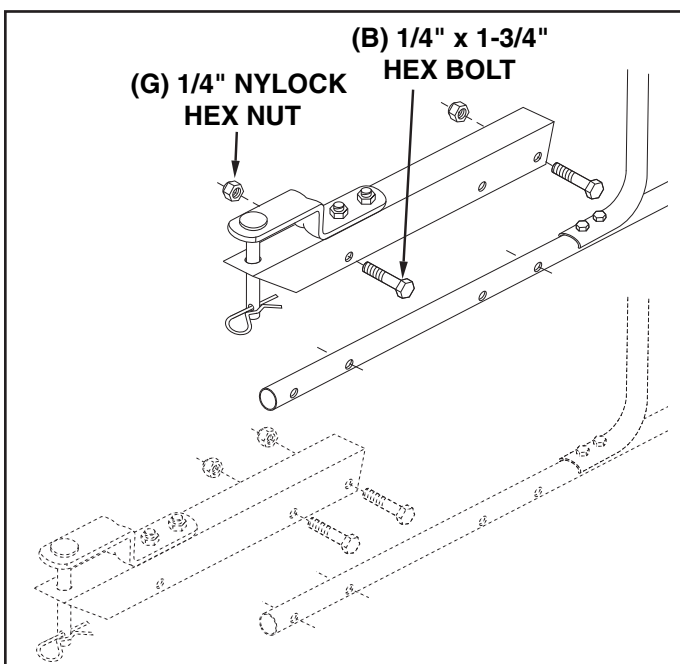

FIGURE 17

## OPERATION

### SETTING THE FLOW CONTROL (figure 14 on page 7.)

1. Loosen the nylon wing nut, set the adjustable stop to the desired flow rate setting and retighten the wing nut. The higher the setting number, the wider the opening in the bottom of the hopper.
2. Refer to the application chart on page 9 and to the instructions on the fertilizer bag to select the proper flow rate setting.
3. Pull the flow control arm against the adjustable stop for the on position and toward the hopper for the off position.

### THE FREE WHEELING FEATURE (figure 4 on page 5.)

The spreader is equipped with a removable pin in the left (drive) wheel. Remove the pin to disengage the drive wheel so that the axle, gears and spreader plate do not rotate. With the drive wheel disengaged, the spreader may be towed at speeds up to 20 mph. If the drive wheel is engaged do not exceed 6 mph.

### USING YOUR SPREADER

We do not recommend the use of any powdered lawn chemicals, due to difficulty in obtaining a satisfactory or consistent broadcast pattern.

1. Determine approximate square footage of area to be covered and estimate amount of material required.
2. Before filling the hopper make sure the flow control arm is in the off position and the closure plate is shut.
3. Break up any lumpy fertilizer as you fill the hopper.
4. Set the adjustable stop with the flow control arm still in the off position. Refer to the application chart on this page and to the instructions on the fertilizer bag to select the proper flow rate setting.
5. The application chart is calculated for light to heavy application at a vehicle speed of 3 mph, or 100 ft. in 23 seconds. A variation in speed will require an adjustment of the flow rate to maintain the same coverage. The faster you drive, the wider the broadcast width.
6. Make sure the drive pin is installed in the axle before starting the spreader.
7. Always start the tractor in motion before opening closure plate.
8. Always shut the closure plate before turning or stopping the tractor.
9. If fertilizer is accidentally deposited too heavily in a small area, soak the area thoroughly with a garden hose or sprinkler to prevent burning of the lawn.
10. To insure uniform coverage, make each pass so that the broadcast pattern slightly overlaps the pattern from the previous pass as shown in figure 18. The approximate broadcast widths for different materials are shown in the application chart on this page.
11. When broadcasting weed control fertilizers, make sure the broadcast pattern does not hit evergreen trees, flowers or shrubs.
12. Heavy moisture conditions may require a cover over the hopper to keep contents dry. The vinyl cover acts as a wind and moisture shield, but should not be used as a rain cover.



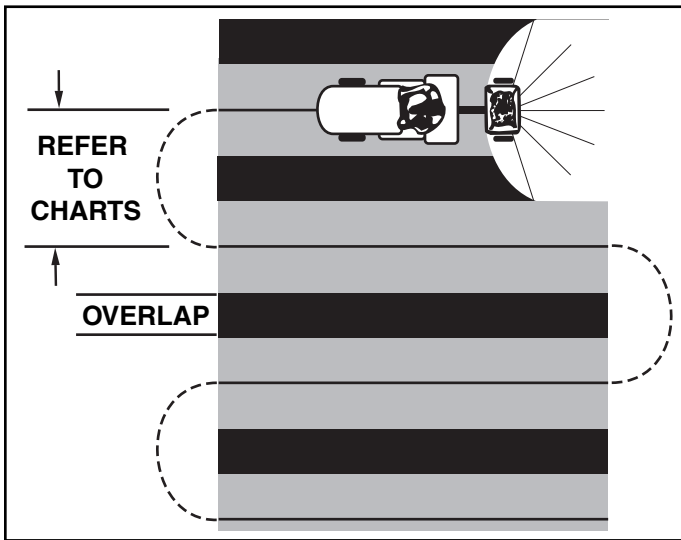

**FIGURE 18**

**IMPORTANT:** Application rates shown in the chart are affected by humidity and by the moisture content of the material (granular and pellet). Some minor setting adjustments may be necessary to compensate for this condition.

APPLICATION CHART		
TYPE MATERIAL	FLOW SETTING	SPREAD WIDTH
<b>FERTILIZER</b>		
Powder	3 - 5	3' - 4'
Granular	3 - 5	8' - 10'
Pelleted	3 - 5	10' - 12'
Organic	6 - 8	6' - 8'
<b>GRASS SEED</b>		
Fine	3 - 4	6' - 7'
Coarse	4 - 5	8' - 9'
<b>ICE MELTER</b>	6 - 8	10' - 12'

**OPERATING SPEED** - 3 MPH. (100 ft. in 23 seconds)

## MAINTENANCE

### CHECK FOR LOOSE FASTENERS

1. Before each use make a thorough visual check of the spreader for any bolts and nuts which may have loosened. Retighten any loose bolts and nuts.

### CHECK FOR WORN OR DAMAGED PARTS

2. Check for worn or damaged parts before each use. Repair or replace parts if necessary.

## CHECK TIRE INFLATION

3. Check if tires are adequately inflated before each use. Do not inflate beyond maximum recommended pressure.



**CAUTION: DO NOT** inflate tires beyond the maximum recommended pressure printed on side of tire.

## CLEANING

4. Rinse inside of hopper and exterior of spreader and dry off before storing.

## LUBRICATE (See figure 19)

5. Lightly apply automotive grease as needed to the sprocket and gear.
6. Oil the nylon bushings on the vertical sprocket shaft and on the axle at least once a year, or more often as needed.
7. Oil right hand (idler) wheel bearing at least once a year or more often as needed.

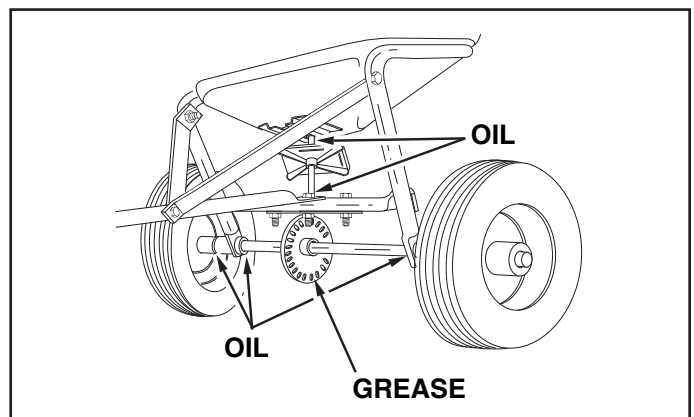

**FIGURE 19**

## STORAGE

1. Rinse inside of hopper and exterior of spreader and dry off before storing.
2. Store in a clean, dry area.

## SERVICE AND ADJUSTMENTS

1. If the axle, slotted gear and sprocket assembly is disassembled, mark down the positions of the parts as they are removed. The drive wheel and sprocket positions in relation to the slotted gear determine which direction the spreader plate will spin. Be sure to reassemble them in their original positions. (Refer to figure 4 on page 5.) Use shim washers (Ref. no. 21 on pages 10 and 11) as needed for minimum backlash. Add grease to gear and sprocket.

# REPAIR PARTS FOR BROADCAST SPREADER MODEL NO. 45-03641, 45-03642

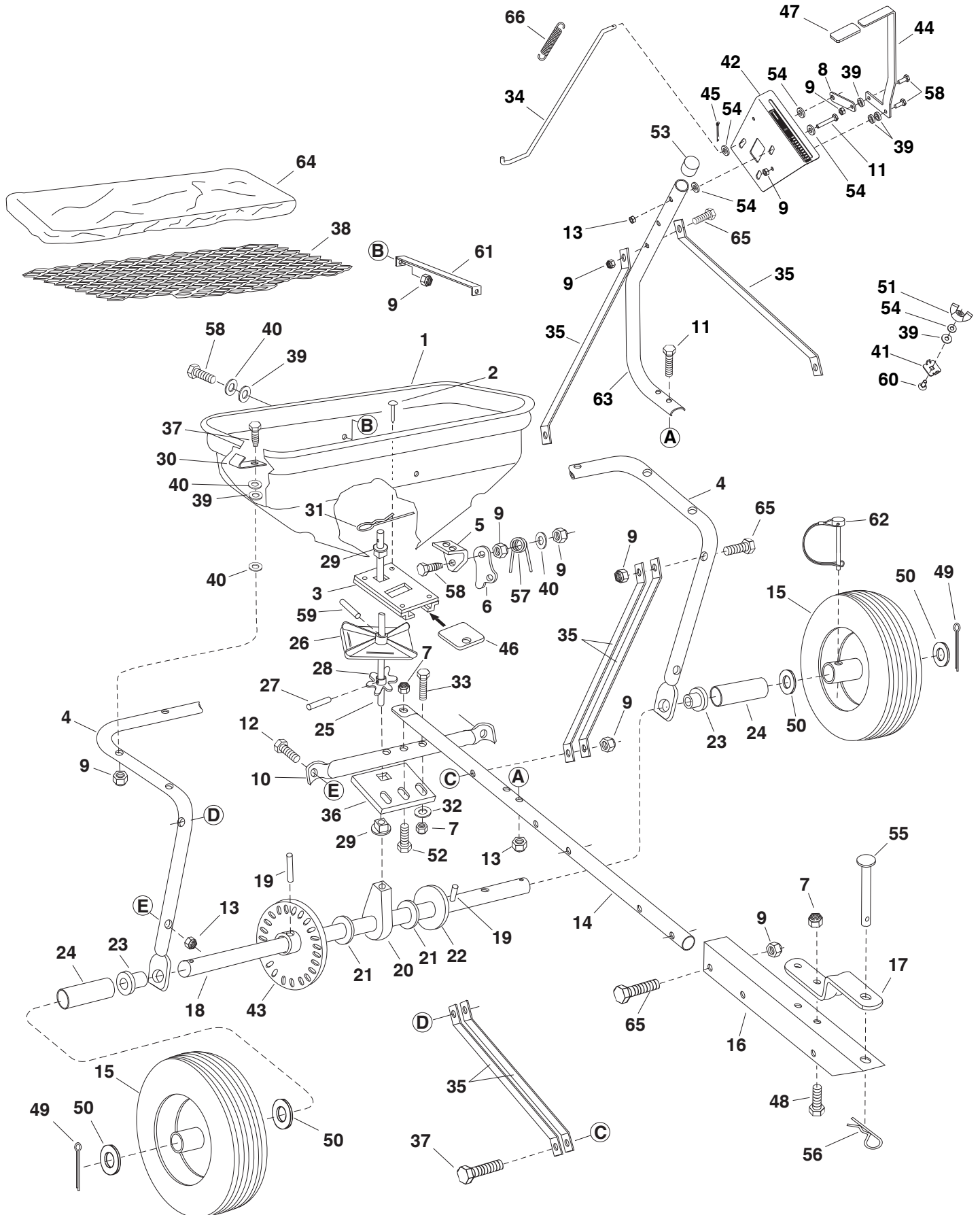

## REPAIR PARTS FOR BROADCAST SPREADER MODEL NO. 45-03641, 45-03642

REF. NO.	PART NO.	QTY.	DESCRIPTION	REF. NO.	PART NO.	QTY.	DESCRIPTION
1	49414	1	Hopper	35	23525	6	Brace, Hitch
2	43882	4	Rivet, Stainless	36	23762	1	Shaft Support Plate
3	65129	1	Ass'y, Guide Closure	37	46699	7	Bolt, Hex 1/4-20 x 2"
4	44462	1	Tube, Frame	38	47441	1	Screen
5	23753	1	Slide Gate Angle Bracket	39	1543-69	12	Washer, Nylon
6	23758	1	Slide Gate Bracket	40	43088	15	Washer, Flat 1/4" Std.
7	HA21362	5	Nut, Hex 3/8-16 Nylock	41	24858	1	Stop, Adjustable
8	24857	1	Flow Control Link	42	24915	1	Bracket, Flow Control Mount
9	47189	18	Nut, Hex 1/4-20 Nylock	43	62474	1	Gear Assembly
10	43808	1	Tube, Crossover	44	24917	1	Flow Control Arm
11	43084	4	Bolt, Hex 5/16-18 x 1-3/4" Lg.	45	44101	1	Cotter Pin 3/32" x 3/4" Lg.*
12	44180	2	Bolt, Hex 5/16-18 x 2" Lg.	46	23533	1	Plate, Closure
13	47810	6	Nut, Hex 5/16-18 Nylock	47	43848	1	Grip, Flow Control Arm
14	48864	1	Tube, Hitch	48	43407	2	Bolt, Hex 3/8-16 x 3/4" Lg. *
15	48511	2	Wheel	49	43093	2	Pin, Cotter 1/8" x 1-1/2"
16	25080	1	Bracket, Hitch Extension	50	43009	4	Washer, Flat 3/4"
17	23014	1	Bracket, Hitch	51	47141	1	Wing Nut, Nylon
18	24914	1	Shaft, Axle	52	HA180132	1	Bolt, Hex 3/8-16 x 2-1/4" Lg. *
19	43851	2	Pin, Spring 3/16" Dia. x 1-1/4"	53	44481	1	Vinyl Cap
20	43871	1	Bushing, Axle Shaft	54	R19111116	7	Washer, 5/16 SAE
21	1540-32	5	Washer, Flat .78 I.D.	55	47623	1	Hitch Pin
22	1540-162	1	Washer, Flat 3/4"	56	43343	1	Hair Cotter Pin, 1/8"
23	47615	2	Bearing, Flange	57	44566	1	Spring, Torsion
24	47683	2	Tube, Spacer	58	43661	5	Bolt, Hex 1/4-20 x 1" Lg.*
25	25305	1	Shaft, Sprocket	59	46055	1	Pin, Spring 1/8" Dia. x 1" Lg.
26	04367	1	Spreader Impeller	60	44950	1	Bolt, Carriage 1/4-20 x 3/4"
27	43850	1	Pin, Spring 1/8" Dia. x 5/8".	61	25433	1	Strap, Hopper
28	44468	1	Sprocket, 6 Tooth	62	48515	1	Drive Pin W/Bail, 1/4" x 2"
29	44285	2	Bushing, Delrin	63	48514	1	Flow Control Mounting Tube
30	25672	2	Clip	64	49504	1	Vinyl Cover
31	48934	1	Hairpin Agitator	65	1509-69	5	Bolt, Hex 1/4-20 x 1-3/4" Lg.*
32	43070	5	Washer, Flat 3/8" *	66	43000	1	Spring
33	43054	2	Bolt, Hex 3/8-16 x 2" Lg.*		49857	1	Owner's Manual
34	48586	1	Rod, Flow Control				

\* Purchase common hardware locally.

**SpeedEPart** *the fastest way to purchase parts* [www.speedepart.com](http://www.speedepart.com)

***SpeedPart*** *the fastest way to purchase parts* [www.speedepart.com](http://www.speedepart.com)

**REPAIR PARTS**

Agri-Fab, Inc.  
809 South Hamilton  
Sullivan, IL. 61951  
217-728-8388  
[www.agri-fab.com](http://www.agri-fab.com)