

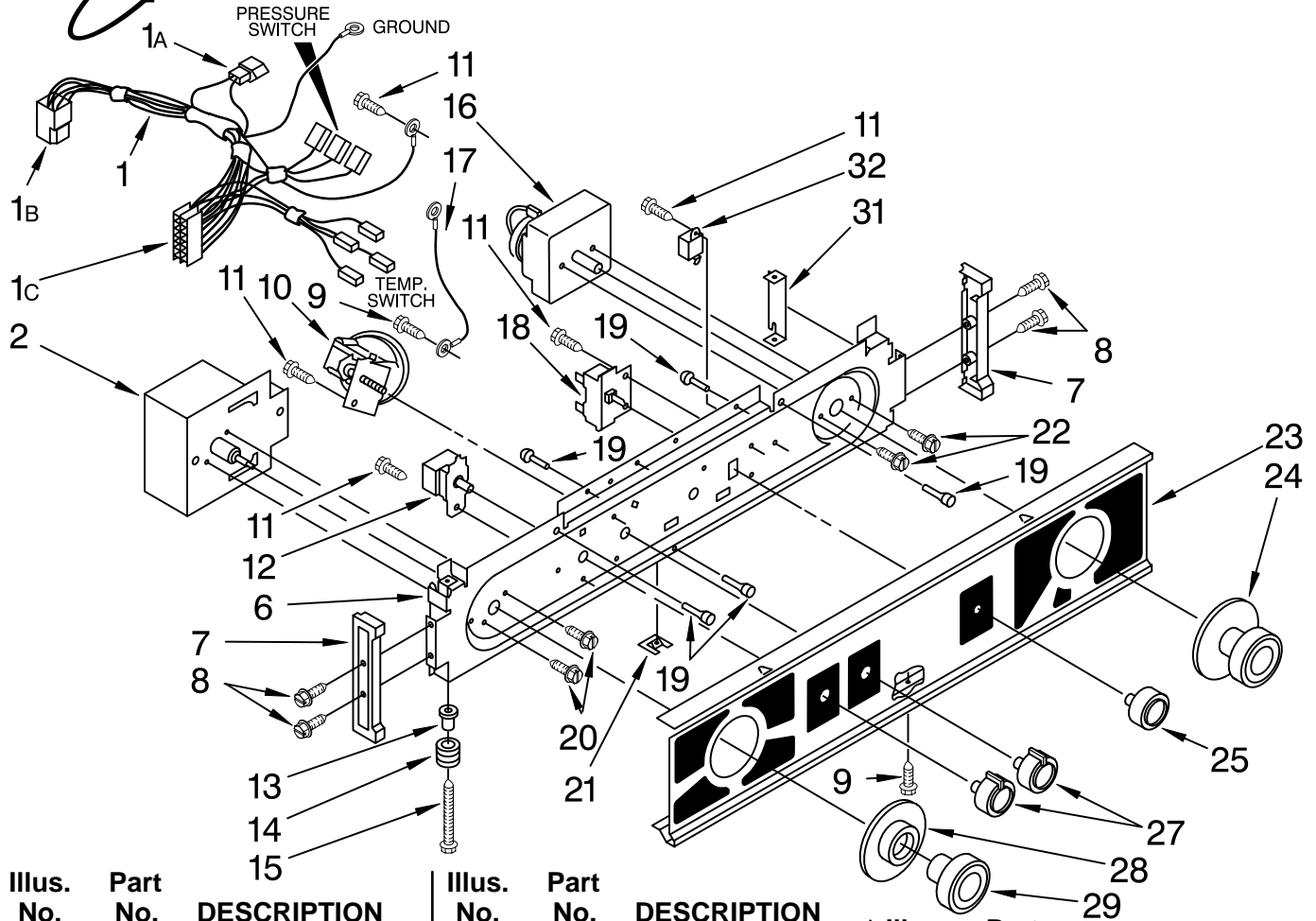

# WASHER/DRYER CONTROL PANEL PARTS

For Models: LTG5243DQ0, LTG5243DZ0  
(Designer White) (Designer Almond)

WASHER/DRYER  
LAUNDRY SYSTEM



Illus. No.	Part No.	DESCRIPTION
1	3404403	Harness, Console Wiring (Automatic) (Includes Illus. 1A, 1B & 1C)
1A	3350130	Plug, Terminal (2-Way) (Connects With Main Dryer Harness)
1B	696073	Receptacle, Connector (Connects With Lower Automatic Harness)
1C	352089	Disconnect Block (Connects With Automatic Timer)
2	3948891	Timer, Control (60 Hz.) (Automatic Washer)
6	694338	Bracket, Control
7	692993	End Cap, Console (L.H. & R.H.)
8	348689	Screw, End Cap Mounting (4) (6-32 x 3/4)

Illus. No.	Part No.	DESCRIPTION
9	694091	Screw, Mounting (2) #8 Posidrive
10	3362987	Switch, Water Level
11	339554	Screw
12	3363042	Switch, Water Temperature
13	693711	Sleeve, Console Lock Screw (2)
14	693151	Spring, Console Lock (2)
15	693710	Screw, Console Lock (2)
16	696165	Timer, Control (60 Hz.) (Dryer) (Timer Motor Not Serviceable)
17	693175	Strut, Console
18	660936	Switch, Push-To-Start
19	693152	Bumper, Console (5)
20	96435	Screw, Timer Mounting (2)
21	694037	Clip, Console
22	3400801	Screw, Dryer Timer Mounting (2) (8-32 x 3/16)

Illus. No.	Part No.	DESCRIPTION
23	3404262	Panel, Control White
	3404263	Almond
24	3396150	White Knob, Timer (Dryer)
	3396151	Almond
25	3396161	White Knob, Push-To-Start
	3396164	Almond
27	3358435	White Knob, Control (2)
	3358436	Almond
28	3403095	White Dial, Timer (Washer)
	3403096	Almond
29	3364291	White Knob, Timer (Washer)
	3364293	Almond
31	692983	Lock, Console (2)
32	694419	Buzzer

FOR ORDERING INFORMATION REFER TO PARTS PRICE LIST

# DRYER FRONT PANEL AND DOOR PARTS

For Models: LTG5243DQ0, LTG5243DZ0  
(Designer White) (Designer Almond)

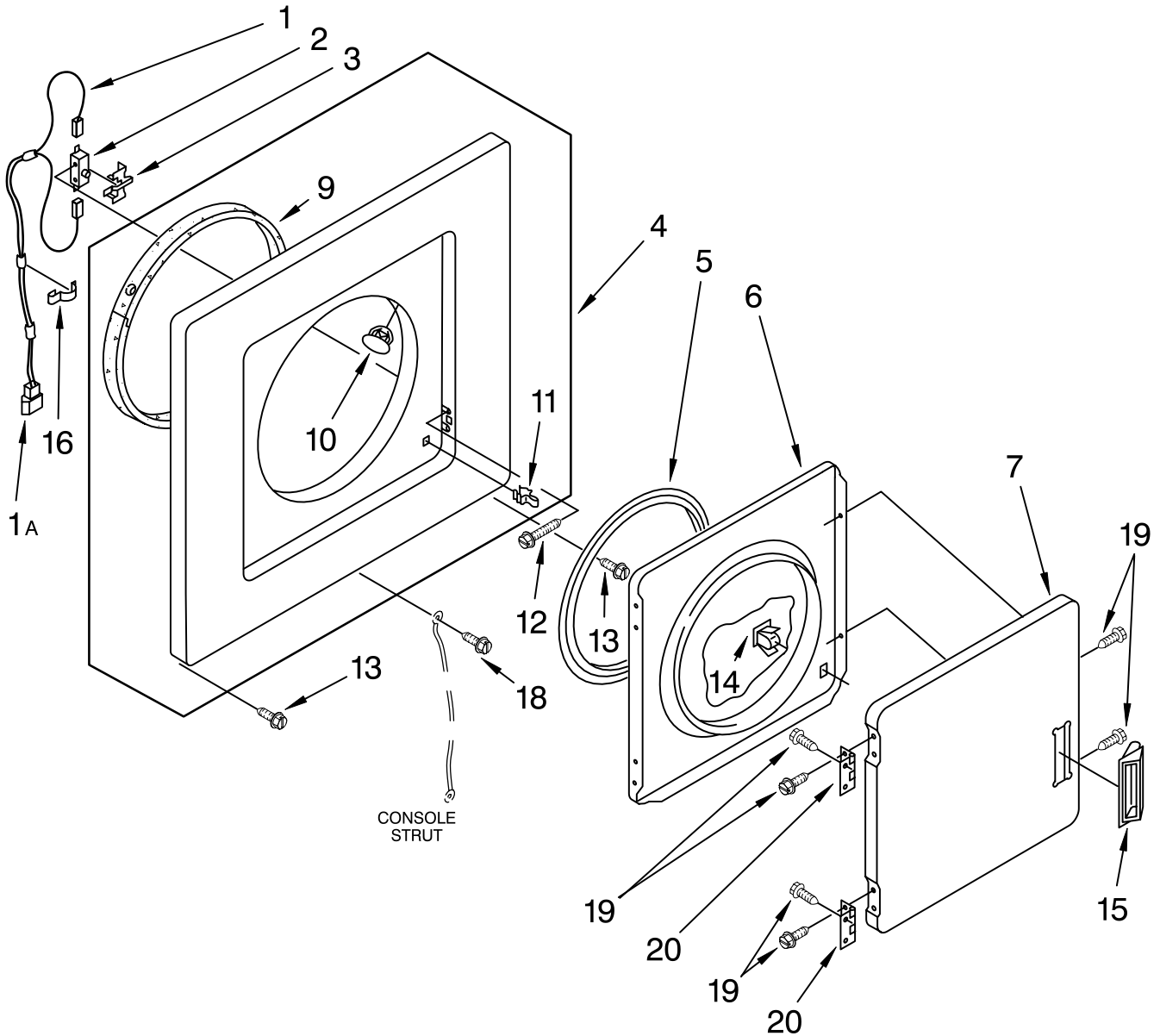

Illus. No.	Part No.	DESCRIPTION	Illus. No.	Part No.	DESCRIPTION	Illus. No.	Part No.	DESCRIPTION
1	692728	Harness, Door Switch (Includes Illus. 1A)	6	695656	Door, Rear	14	3389441	Catch, Door
1A	717253	Plug, Terminal (2-Way) (Connects With Main Dryer Harness)	7	348205	White Door, Front	15	686711	White Handle, Door
2	347207	Switch, Door		689314	Almond		689308	Almond
3	691581	Lever, Door Switch Panel, Front	9	349462	Bearing & Seal	16	692846	Support Protector
4	692619	White Panel, Front	10	685203	Clip, Felt Pad (2)	18	339554	Screw, Console Strut Mounting
	692620	Almond	11	696144	Strike, Panel	19	694091	Screw, Door Mount To Hinge & Panel (10)
5	3390734	Seal, Door	12	98129	Screw, Door Switch Mounting (2)	20	348023	Hinge & Pin, Door (2)
			13	343641	Screw, 10-16 x 1/2 (2) (Front Panel To Side Panel)			

FOR ORDERING INFORMATION REFER TO PARTS PRICE LIST

# DRYER CABINET AND MOTOR PARTS

For Models: LTG5243DQ0, LTG5243DZ0  
(Designer White) (Designer Almond)

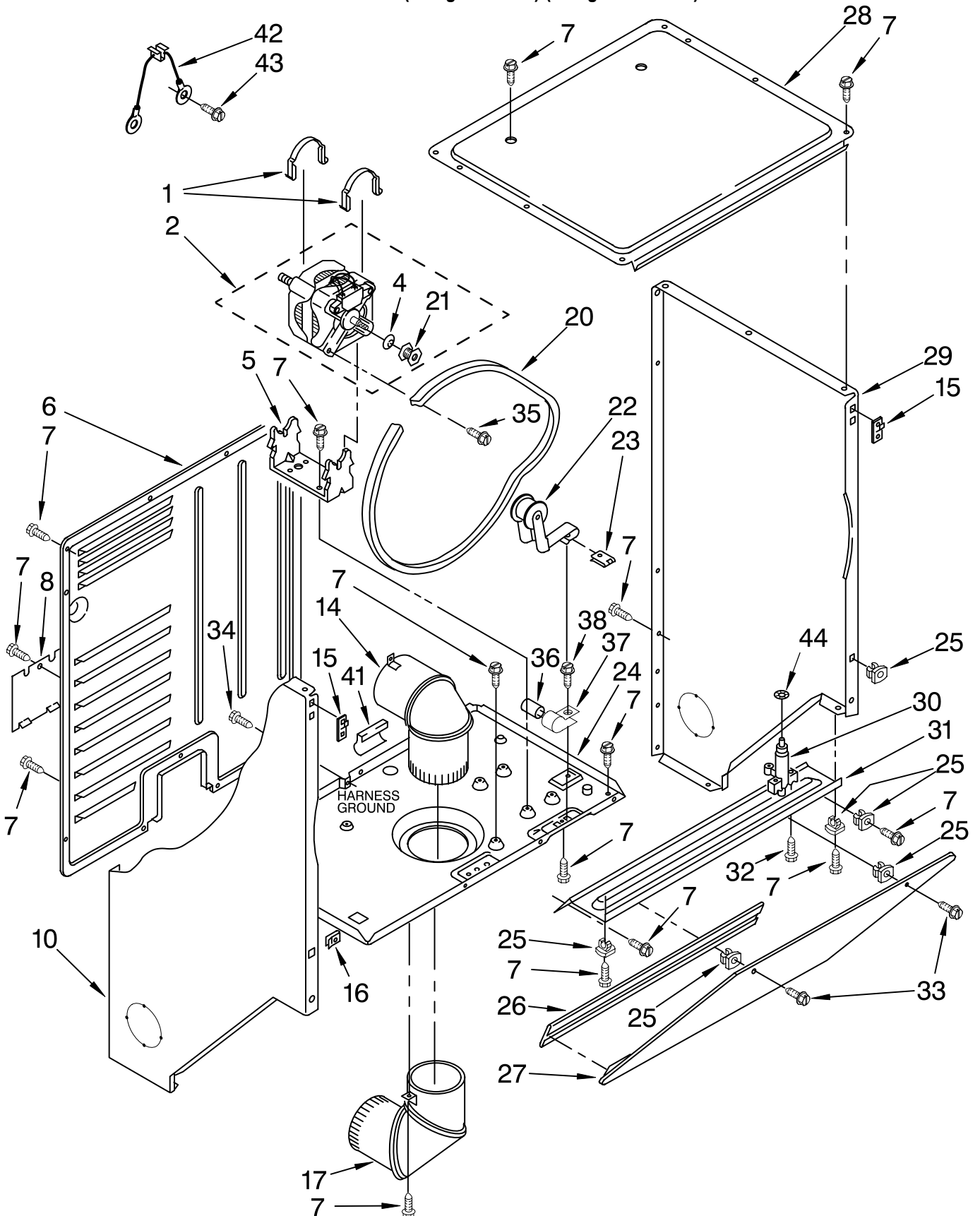

FOR ORDERING INFORMATION REFER TO PARTS PRICE LIST

# DRYER CABINET AND MOTOR PARTS

For Models: LTG5243DQ0, LTG5243DZ0  
(Designer White) (Designer Almond)

Illus. No.	Part No.	DESCRIPTION	Illus. No.	Part No.	DESCRIPTION	Illus. No.	Part No.	DESCRIPTION
1	660658	Clamp, Motor Mounting (2)	20	3394652	Belt, Drive	32	354975	Screw & Washer (3)
		343481 (Alt.)	21	3396426	Pulley, Motor (60 Hz.)			(Lid Latch Mounting)
		685441 (Alt.)	22	691366	Idler & Bracket	33	693304	Screw & Washer (2)
2	3398046	Motor, Main Drive (60 Hz.)	23	692771	Nut, Idler Bracket To Base			(Transition Panel To Closure)
4	3393657	Restrainer, Belt	24	3399633	Base, Dryer	34	697776	Screw, Ground (2)
5	696541	Bracket, Motor	25	692400	Nut, Push-In			(10-32 x 1/2)
6	3390405	Panel, Rear	26	692926	Cove, Transition Panel (Black)	35	3390631	Screw, 10-16 x 3/8
7	343641	Screw, 10-16 x 1/2	27		Panel, Transition	36	357021	Capacitor, Motor Start (Automatic Washer)
8	307972	Cover, Terminal Block		692933	White			
10		Panel, Side (L.H.)		692934	Almond	37	357030	Clamp, Capacitor
	3402293	White	28	692641	Top, Dryer	38	343641	Screw, Capacitor Mounting
	3402294	Almond	29		Panel, Side (R.H.)			(10-16 X 1/2)
14	3399602	Elbow, Upper		3402287	White	41	686770	Edge, Protector
15	3394083	Clip, Front Panel (2)		3402288	Almond	42	3388580	Cable
16	98234	Clip, Ground	30	693145	Latch, Lid	43	343641	Screw,
17	3399603	Elbow, Lower	31		Closure, Control Area			10-16 x 1/2 (2)
				692781	White	44	90296	Clip
				692782	Almond			

FOR ORDERING INFORMATION REFER TO PARTS PRICE LIST

# DRYER BULKHEAD PARTS

For Models: LTG5243DQ0, LTG5243DZ0  
(Designer White) (Designer Almond)

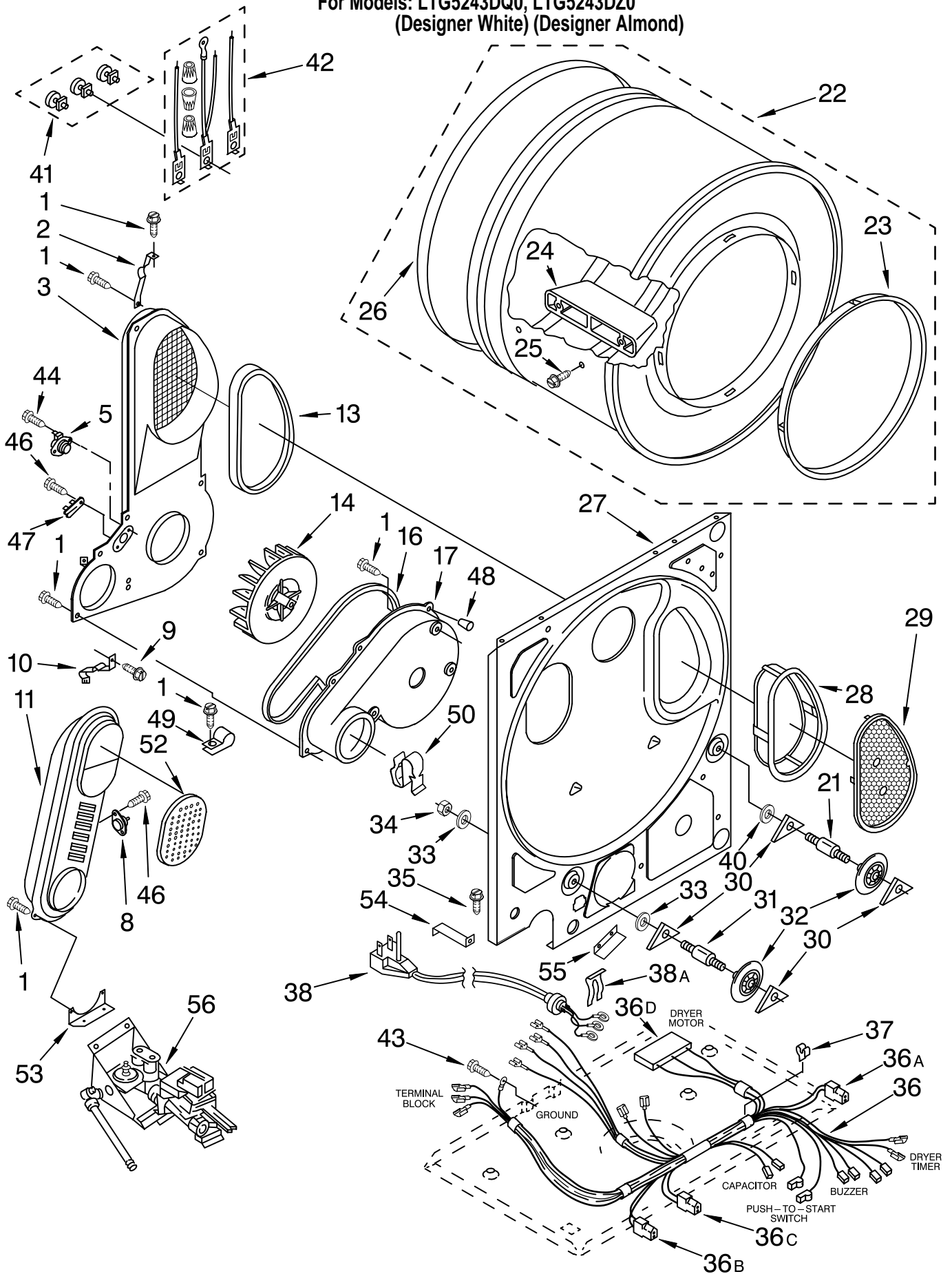

# DRYER BULKHEAD PARTS

For Models: LTG5243DQ0, LTG5243DZ0  
(Designer White) (Designer Almond)

Illus. No.	Part No.	DESCRIPTION	Illus. No.	Part No.	DESCRIPTION	Illus. No.	Part No.	DESCRIPTION
1	343641	Screw, 10-16 x 1/2	29	685273	Cover, Lint Screen Outlet	37	693141	Clip, Wiring Harness (3)
2	3395396	Clip, Air Duct To Bulkhead	30	690997	Tri-Ring (4)	38	694018	Cord, Power
3	696529	Air Duct & Cover	31	3399506	Shaft, Drum Roller (L.H.)	38a	694415	Strain Relief, Power Cord
5	3398128	Thermostat, Internal Bias	32	3397588	Roller, Support (2)	40	3388703	Washer, Support
8	3403140	Thermostat, Heater Box 205°F 96°C	33	348197	Washer, Support (4)	41	279393	Screw Kit (For Terminal Block)
9	3400800	Screw, 8-18 x 3/4	34	3359452	Nut, 3/8-16 (2)	42	279318	Terminal, Tinned & Brass (3) (Includes Illus. 41)
10	3398161	Clip, Heater Box To Bulkhead	35	3390631	Screw, 10-16 x 3/8 (Bulkhead To Base)	43	697776	Screw, Ground (2) (10-32 x 1/2)
11	697269	Heater Box	36	3398874	Harness, Main Dryer Wiring (Includes Illus. 36A, 36B, 36C, 36D & 36E)	44	3390647	Screw, 8-18 x 1/2
13	339956	Seal, Air Duct To Bulkhead	36A	717252	Receptacle, Terminal (2-Way) (Connects With Door Switch Harness)	46	90767	Screw, 8-18 X 3/8
14	696426	Wheel, Blower	36B	697780	Receptacle, (Gas Valve)	47	3392519	Fuse, Thermal
16	696658	Seal, Fan Scroll	36C	62889	Receptacle, Terminal (2-Way) (Connects With Automatic Console Harness)	48	359702	Cap, Screw
17	696418	Fan Scroll	36D	3395683	Receptacle, Multi-Terminal (Connects With Dryer Motor)	49	255563	Clip, Strain Relief
21	3399507	Shaft, Drum Roller (R.H.)				50	697439	Clip, Harness To Duct (2)
22	695943	Drum, Dryer				52	345335	Cover, Manifold
23	3394508	Ring, Bearing				53	347455	Support, Heater Box
24	685207	Baffle, Drum (3)				54	3387208	Support, Corner Gas
25	697777	Screw, Baffle Mounting (6) (11-16 x 7/8)				55	697571	Guard, Sock
26	345648	Seal, Drum Rear				56	3401796	Burner (Refer to page 19 For Complete Breakdown)
27	697540	Bulkhead						
28	348399	Lint Screen						

FOR ORDERING INFORMATION REFER TO PARTS PRICE LIST

# DRYER SUPPORT AND WASHER PARTS

For Models: LTG5243DQ0, LTG5243DZ0  
(Designer White) (Designer Almond)

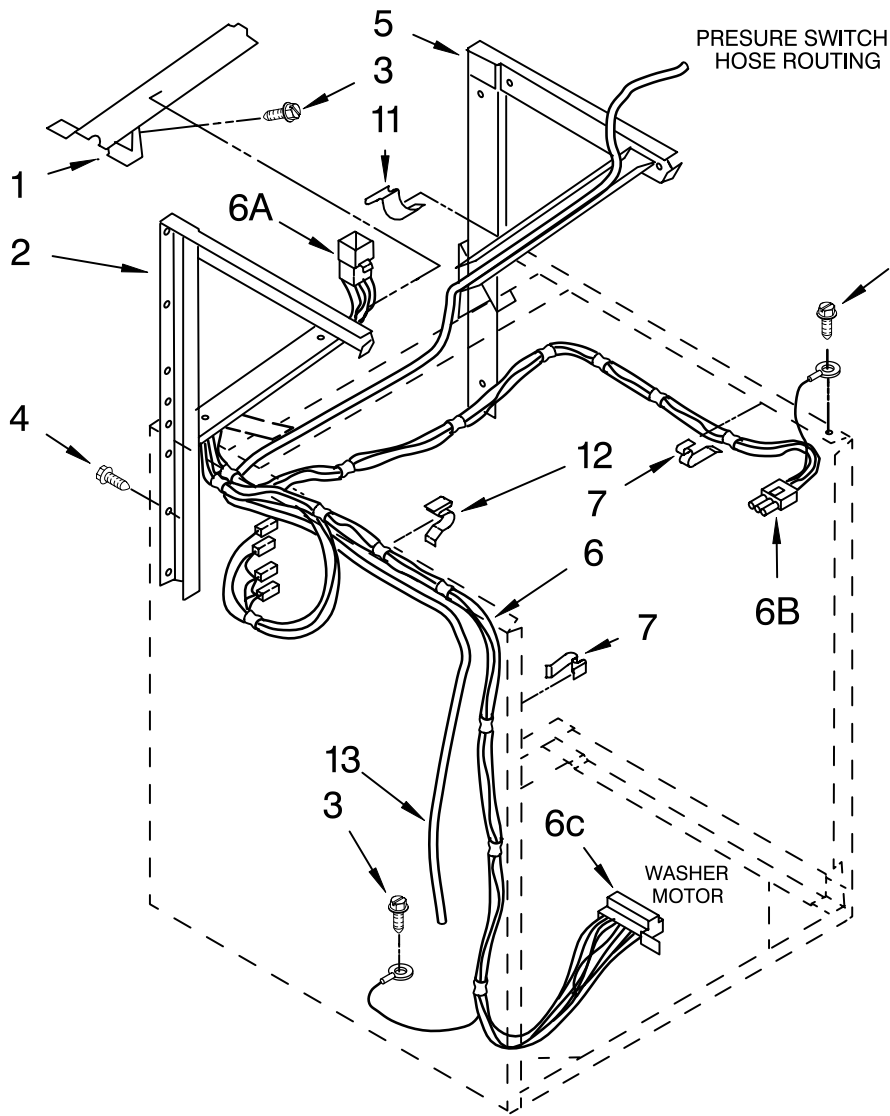

Illus. No.	Part No.	DESCRIPTION
1	694304	Cover, Channel
2	692647	Support, Dryer (L.H.)
3	343641	Screw, 10-16 x 1/2
4	3400000	Screw, 10-24 x 3/8 (8) (Washer Cabinet To Dryer Supports)
5	692646	Support, Dryer (R.H.)
6	3388677	Harness, Upper (Automatic) (Includes Illus. 6A, 6B & 6C)
6A	696074	Plug, Terminal (12-Way) (Connects With Automatic Console Harness)
6B	62889	Plug, Terminal (3-Way) (Connects With Automatic Lid Switch Harness)
6C	62505	Block, Disconnect (Connects With Automatic Washer Motor)
7	3347812	Clip, Wiring Harness (4)
11	90016	Clip, Pressure Switch Hose (2)
12	693141	Clip, Harness
13	696238	Hose, Pressure Switch

FOR ORDERING INFORMATION REFER TO PARTS PRICE LIST

# WASHER TOP AND LID PARTS

For Models: LTG5243DQ0, LTG5243DZ0  
(Designer White) (Designer Almond)

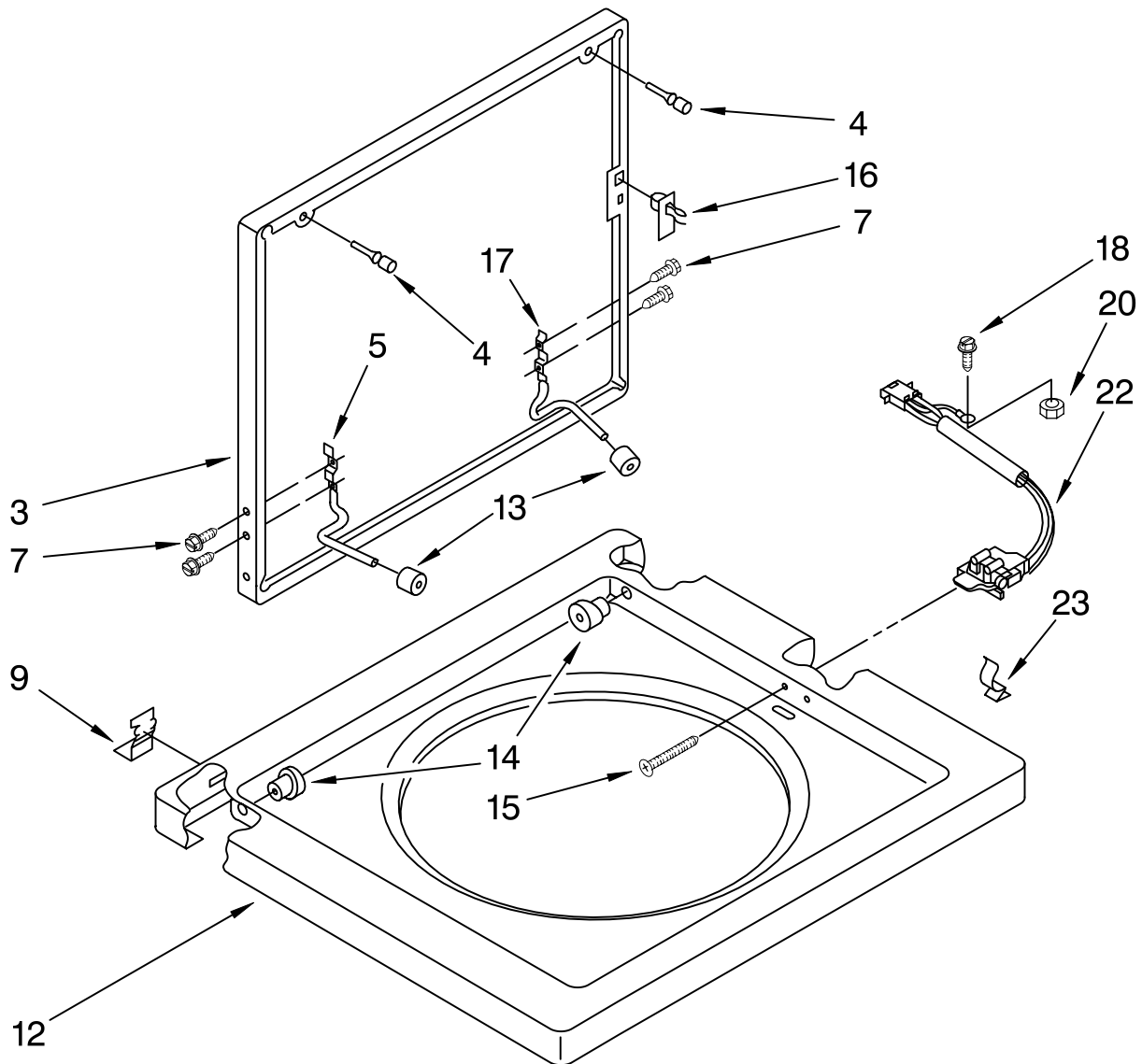

Illus. No.	Part No.	DESCRIPTION
3	3398843	Lid White
	3398844	Almond
4	384475	Bumper, Lid (2)
5	384458	Hinge, Lid (L.H.)
7	3351355	Screw, Lid Hinge Mounting (4)
9	692985	Clip, Spring (2) (Top To Cabinet)

Illus. No.	Part No.	DESCRIPTION
12	384693	Top White
	384694	Almond
13	19119	Bumper, Lid Hinge (2)
14	21258	Bearing, Lid Hinge (2)
15	3356311	Screw & Washer, Lid Switch Shield (2)

Illus. No.	Part No.	DESCRIPTION
16	358684	Strike, Lid Switch
17	384459	Hinge, Lid (R.H.)
18	274707	Screw, Ground (10-24 X 1/2)
20	271166	Nut, Ground Screw (10-24)
22	3355806	Switch, Lid
23	90016	Clip, Harness Routing

FOR ORDERING INFORMATION REFER TO PARTS PRICE LIST



# WASHER CABINET PARTS

For Models: LTG5243DQ0, LTG5243DZ0

(Designer White) (Designer Almond)

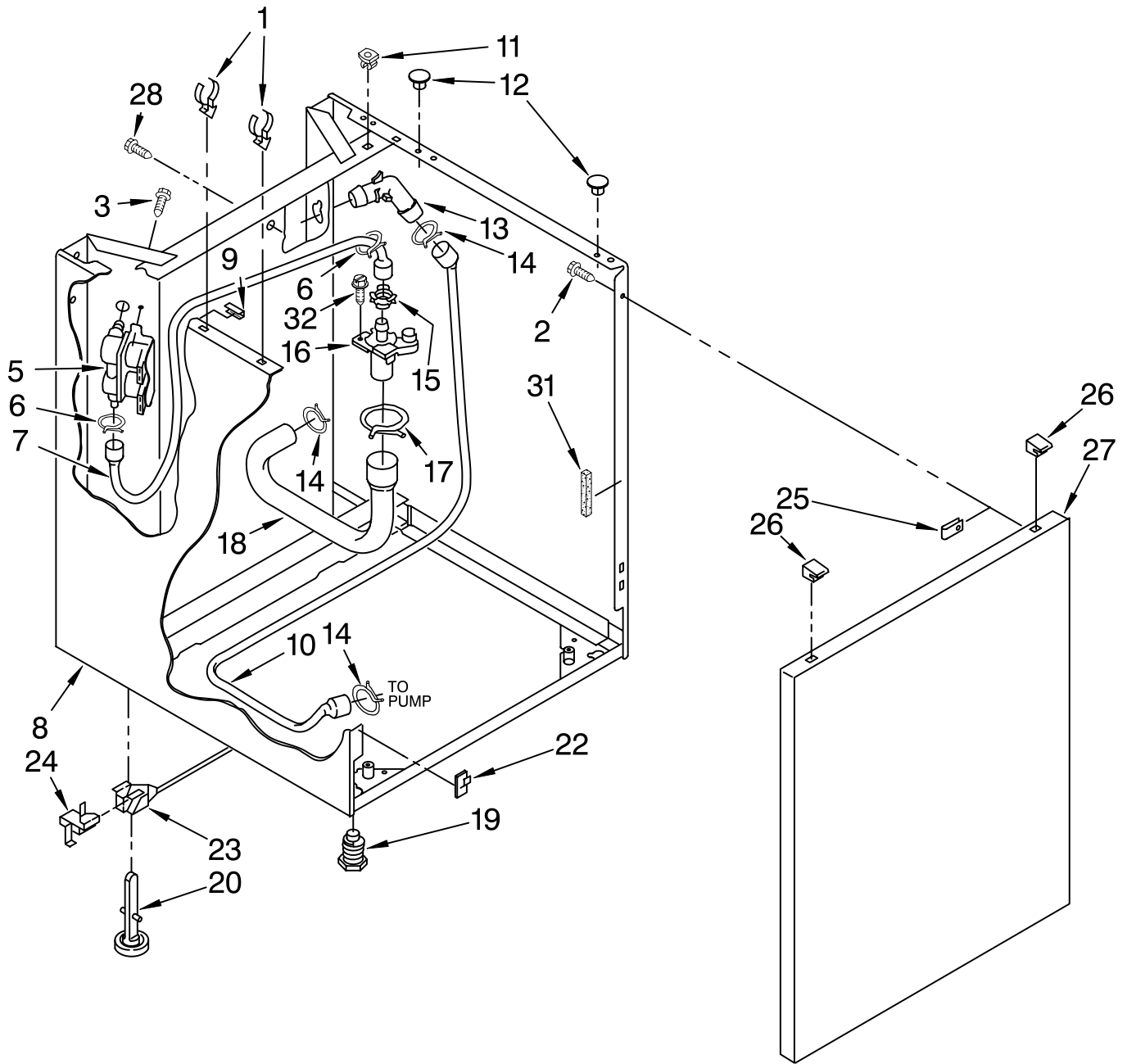

FOR ORDERING INFORMATION REFER TO PARTS PRICE LIST

# WASHER CABINET PARTS

For Models: LTG5243DQ0, LTG5243DZ0  
(Designer White) (Designer Almond)

Illus. No.	Part No.	DESCRIPTION
1	356746	Clip, Condenser (2)
2	343641	Screw, 10-16 X 1/2
3	62863	Screw, Mixing Valve Mounting (2) (10-16 X 3/8)
5	3360389	Valve, Water Mixing
6	370451	Clamp, Hose
7	692699	Hose, Water Inlet (Siphon Break To Mixing Valve)
8		Cabinet
	696013	White
	696014	Almond
9	3390046	Protector, Edge
10	696710	Hose, Drain
11	692400	Nut, Push-In (2)
12	660975	Plug, Top To Cabinet
	689587	(Alt.)
	694010	(Alt.)
13	356739	Connector, Hose
14	660626	Clamp, Hose
15	356471	Cap, Siphon Break
16	356363	Siphon Break
17	272861	Clamp, Hose
18	696394	Hose, Water Inlet (Siphon Break To Tub Ring)
19	367594	Foot, Front (2)
20	358594	Foot, Rear (2)
22	3394083	Clip, Front Panel
23	358652	Link, Leveling
24	359364	Clip, Leveling Mechanism (2)
25	98234	Clip, Ground
26	345670	Lock, Top (2)
27		Panel, Front
	692628	White
	692629	Almond
28	690989	Screw, Ground
31	3350013	Foam (2)
32	64247	Screw

# BRAKE, CLUTCH, GEARCASE, MOTOR AND PUMP PARTS

For Models: LTG5243DQ0, LTG5243DZ0  
(Designer White) (Designer Almond)

Illus. No.	Part No.	DESCRIPTION
1	387948	Brake And Drive Tube (Complete) (Refer To Page 16 For Further Breakdown)
2	63292	Washer, Spin Tube Thrust
3	62697	Ring, Spin Tube Support
4	63283	Ring, Retainer
5	3351342	Clutch (Complete)
6	3946793	Band and Lining (Includes Illus. 7 & 8)
7	3364271	Spring, Clutch
8	62646	Cap, Clutch Spring (2)
9	3360630	Gearcase (Complete)(Refer To Page 15 For Further Breakdown)

Illus. No.	Part No.	DESCRIPTION
10	3357334	Screw, (3) (Gearcase To Tub Support)
11	62611	Plate, Motor Mount To Gearcase
13	3364003	Coupling, Motor & Isolating
14	661600	Motor, Main Drive
15	3355454	Clip (Anti-Rattle)
16	3946532	Plate, Motor
18	3363394	Pump, Complete
19	62700	Retainer, Pump
20	62850	Switch, Main Drive Motor
21	62691	Grommet, Motor (4)
22	3349637	Retainer, Motor (2)
24	3387485	Screw, 10-16 x 5/8 (2)

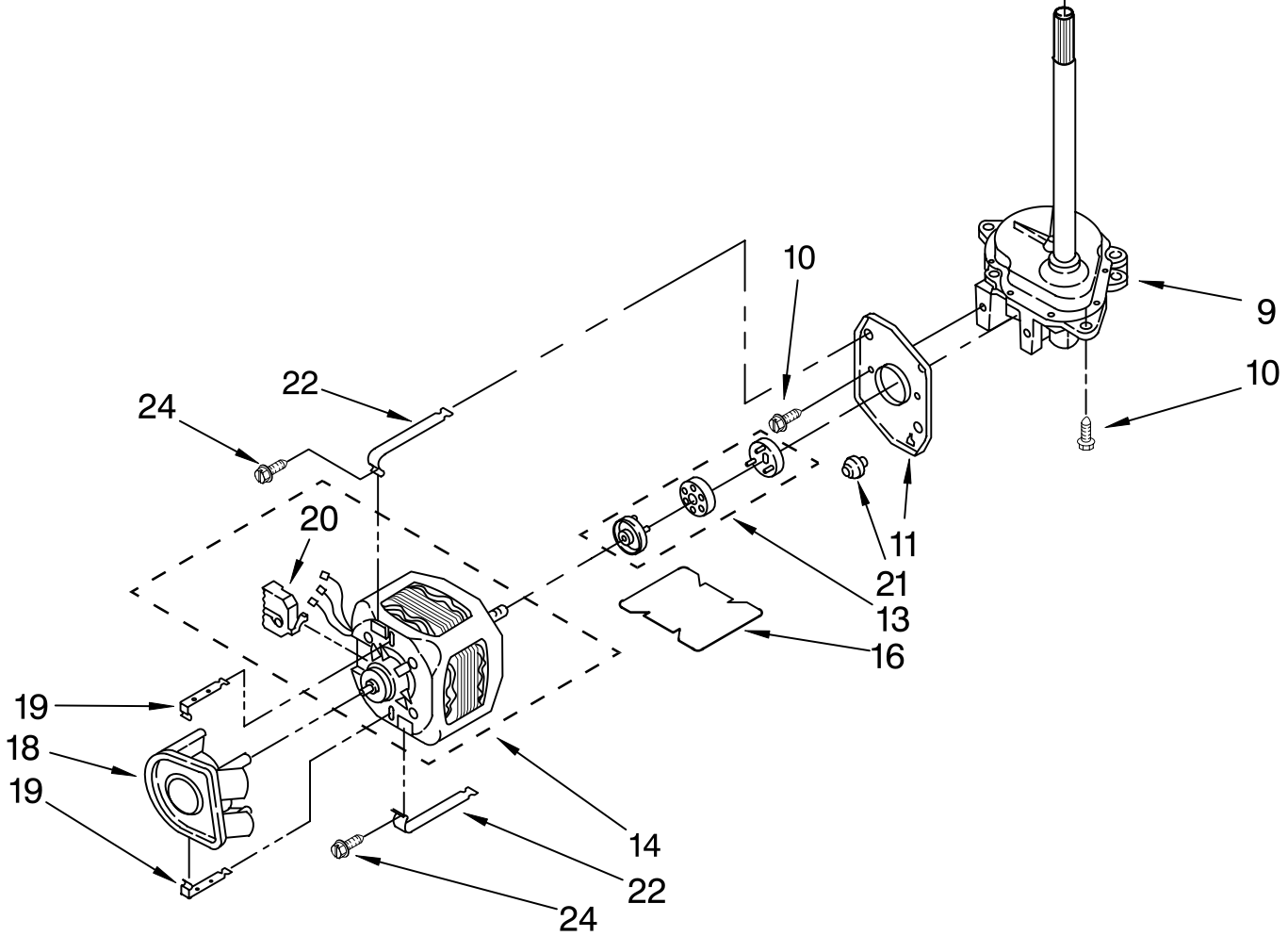
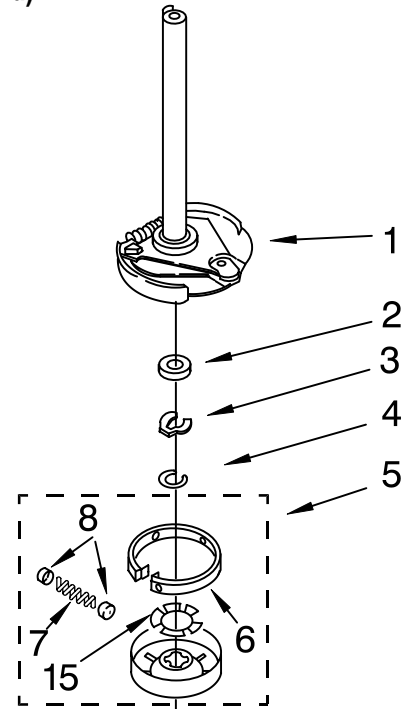

FOR ORDERING INFORMATION REFER TO PARTS PRICE LIST

# MACHINE BASE PARTS

For Models: LTG5243DQ0, LTG5243DZ0  
(Designer White) (Designer Almond)

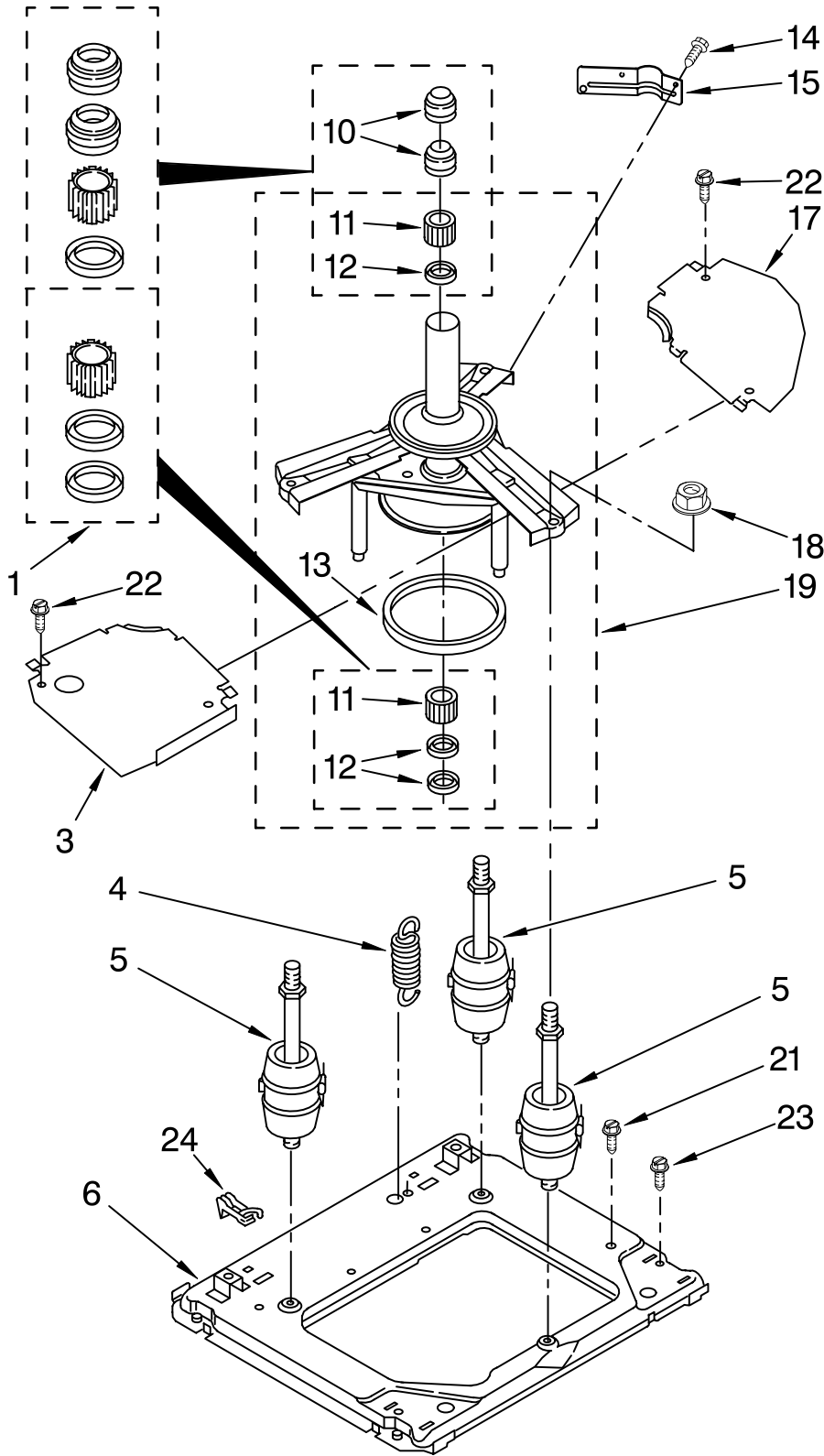

Illus. No.	Part No.	DESCRIPTION
1	285203	Centerpost Bearing Kit (Incls. Illus. 10, 11, & 12)
3	64137	Shield, Tub
4	388492	Spring, Counterweight
5	3350397	Suspension Assembly (3)
6	63755	Base
10	356934	Seal, Centerpost (2)
11	3347047	Bearing, Centerpost (2)
12	357409	Seal, Centerpost (3)
13	63134	Ring, Sound Deadening
14	343641	Screw, 10-16 x 1/2 10-16 X 1/2 (2)
15	63636	Bracket, Counterweight Spring
17	63637	Shield, Tub
18	3351021	Nut, 1/2 - 13 (1)
19	63740	Tub Support and Drum
21	690989	Screw, 10-32 X 1/2 (Grounding)
22	90767	Screw, 8A x 3/8 (4)
23	386011	Screw & Washer (Base To Cabinet)
24	696044	Block, Restraint (2)

FOR ORDERING INFORMATION REFER TO PARTS PRICE LIST

# TUB AND BASKET PARTS

For Models: LTG5243DQ0, LTG5243DZ0  
(Designer White) (Designer Almond)

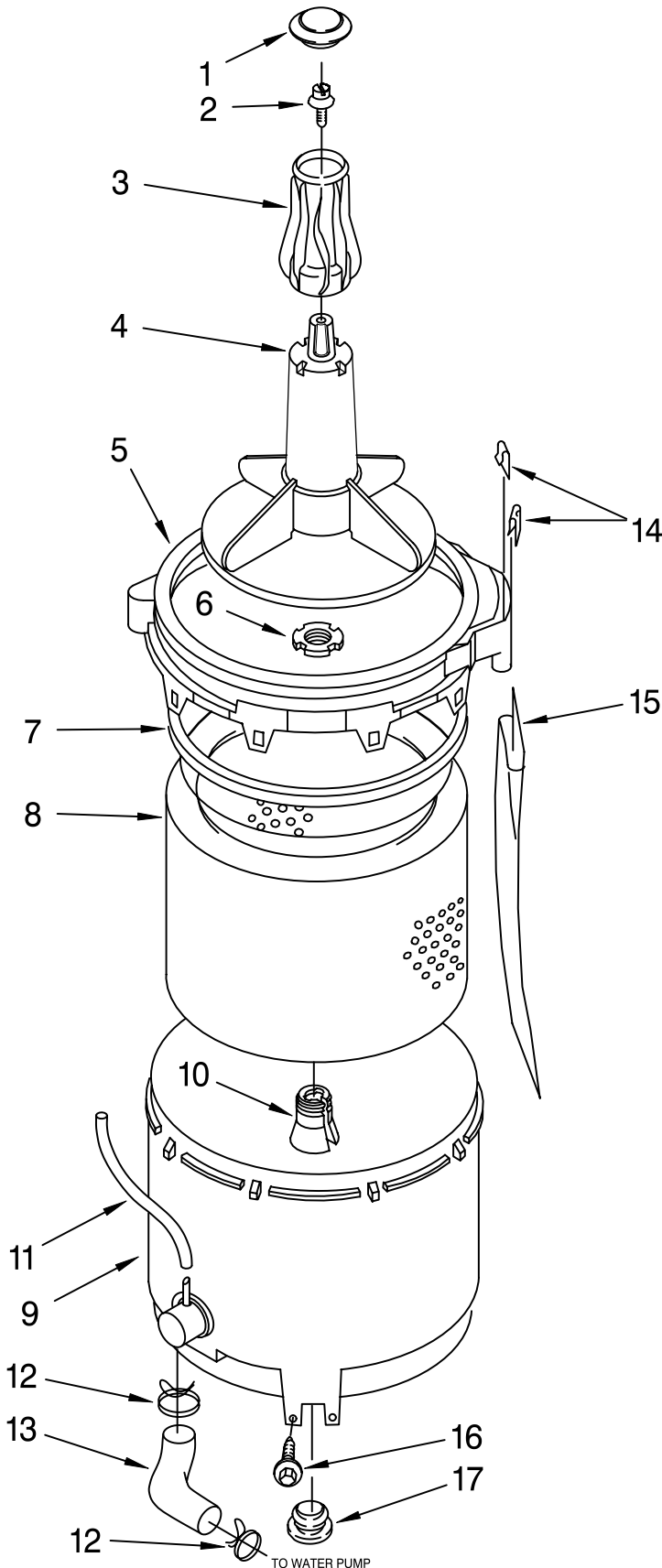

Illus. No.	Part No.	DESCRIPTION
1	3355758	Cap, Agitator
2	358237	Screw & Washer (5/16-24 x 1)
3	63840	Filter, Agitator
4	3349098	Agitator
5	64175	Tub Ring & Gasket (Includes Illus. 7, 14 & 15)
6	21366	Nut, Spanner
7	3359587	Gasket, Tub Ring
8	3351985	Basket
9	63782	Tub
10	389140	Block, Basket Drive
11	696238	Hose, Pressure Switch
12	371502	Clamp, Hose
13	386929	Hose, Tub To Pump
14	352155	Clip, Retaining (2)
15	356398	Tube, Drain Off
16	357640	Screw & Washer (Tub Mounting) (4)
17	383727	Gasket, Centerpost

FOR ORDERING INFORMATION REFER TO PARTS PRICE LIST

# WASHER WATER SYSTEM PARTS

For Models: LTG5243DQ0, LTG5243DZ0  
(Designer White) (Designer Almond)

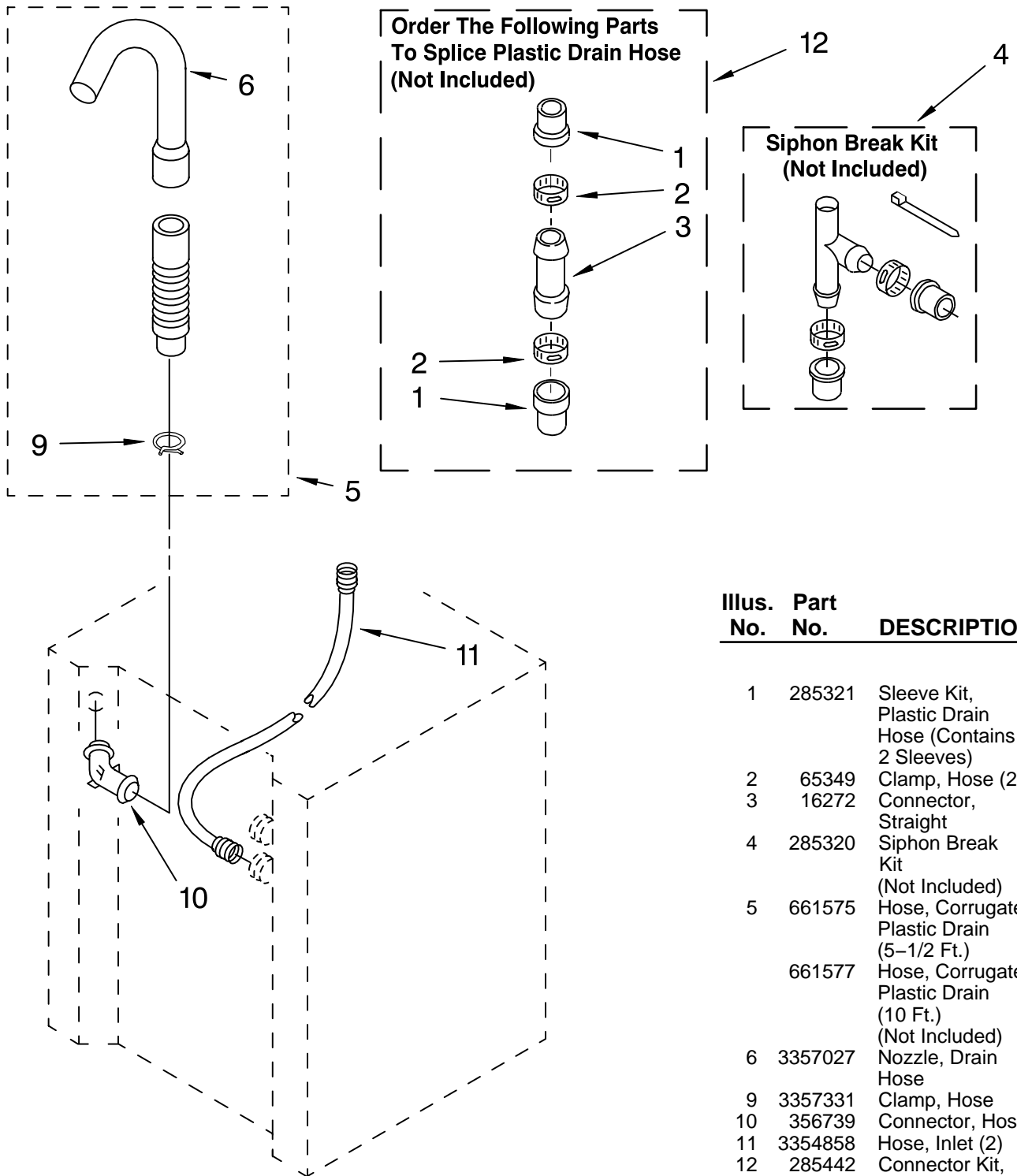

Illus. No.	Part No.	DESCRIPTION
1	285321	Sleeve Kit, Plastic Drain Hose (Contains 2 Sleeves)
2	65349	Clamp, Hose (2)
3	16272	Connector, Straight
4	285320	Siphon Break Kit (Not Included)
5	661575	Hose, Corrugated Plastic Drain (5-1/2 Ft.)
	661577	Hose, Corrugated Plastic Drain (10 Ft.) (Not Included)
6	3357027	Nozzle, Drain Hose
9	3357331	Clamp, Hose
10	356739	Connector, Hose
11	3354858	Hose, Inlet (2)
12	285442	Connector Kit, Plastic Drain Hose

WS900A

FOR ORDERING INFORMATION REFER TO PARTS PRICE LIST

# GEARCASE PARTS

For Models: LTG5243DQ0, LTG5243DZ0  
(Designer White) (Designer Almond)

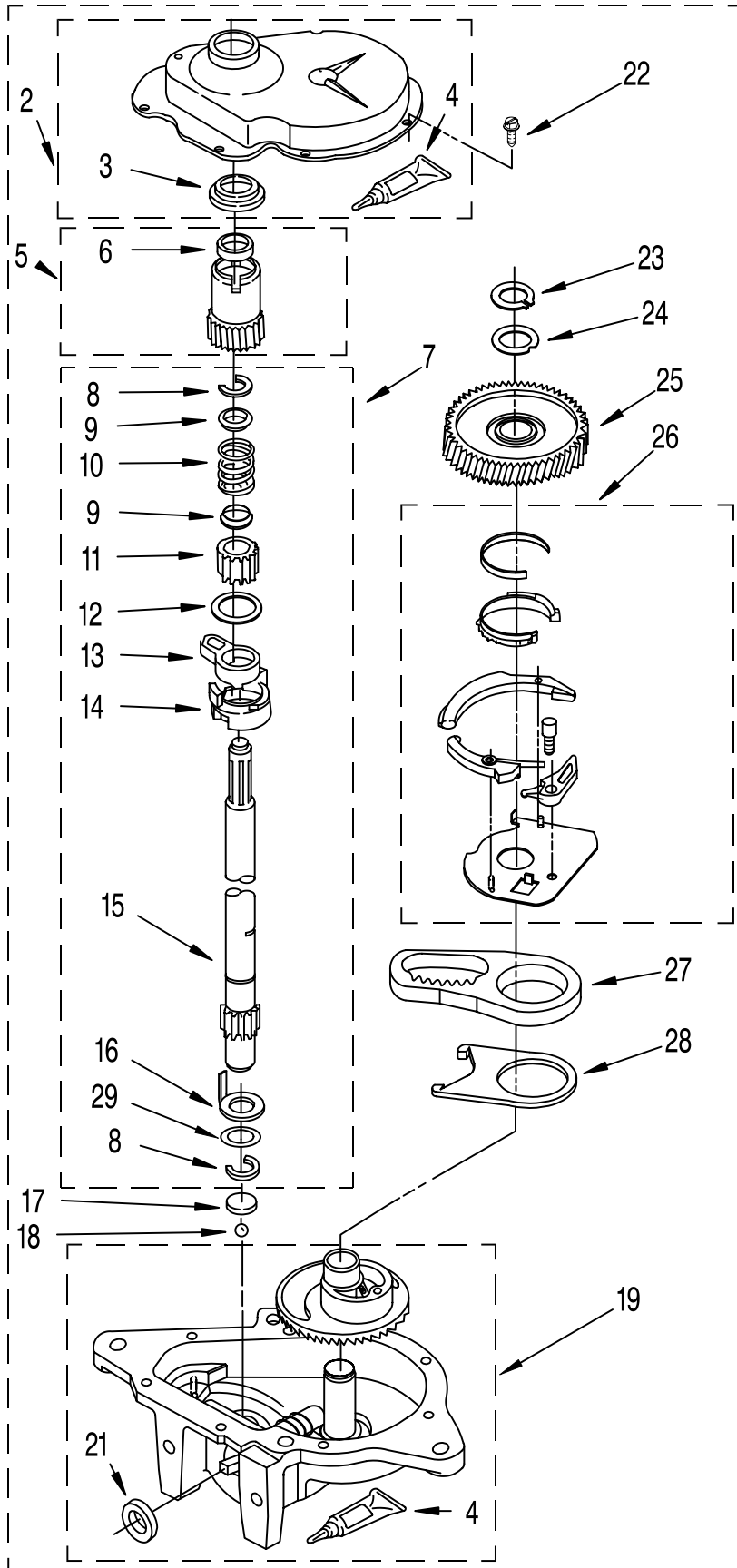

Illus. No.	Part No.	DESCRIPTION
1	3360630	Gearcase (Complete)
2	285202	Cover, Gearcase
3	3349985	Seal, Gearcase Cover
4	285195	Sealer, Gasket (.20 Fl. Oz.) (6 ml)
5	63320	Pinion, Spin (Includes Illus. 25)
6	356427	Seal, Spin Pinion
7	389387	Shaft, Agitator (Complete)
8	90369	Ring, Retaining (2)
9	62677	Retainer, Spring
10	62676	Spring, Agitate
11	63273	Gear, Agitate (Includes 15 and 29)
12	62619	Washer, Agitate Gear
13	62580	Cam Follower (Includes 14)
14	62581	Cam, Agitate (Includes 13)
15	285509	Shaft, Agitator (Includes 11 and 29)
16	62618	Washer, Cam Thrust
17	16018	Bearing, Thrust
18	85529	Ball, Bearing
19	389230	Bottom and Pinion, Gearcase
21	285352	Seal, Thrust Plug
22	3351614	Screw, Gearcase Cover, Mounting (8) (10-24 x 3/8)
23	3362552	Ring, Retaining
24	285735	Washer Kit, Thrust
25	62570	Gear, Spin
26	388253	Neutral Assembly
27	3349296	Rack, Connecting
28	62621	Actuator, Shift
29	388815	Washer, Intermediate

GC-215C

FOR ORDERING INFORMATION REFER TO PARTS PRICE LIST

# BRAKE AND DRIVE TUBE PARTS

For Models: LTG5243DQ0, LTG5243DZ0  
(Designer White) (Designer Almond)

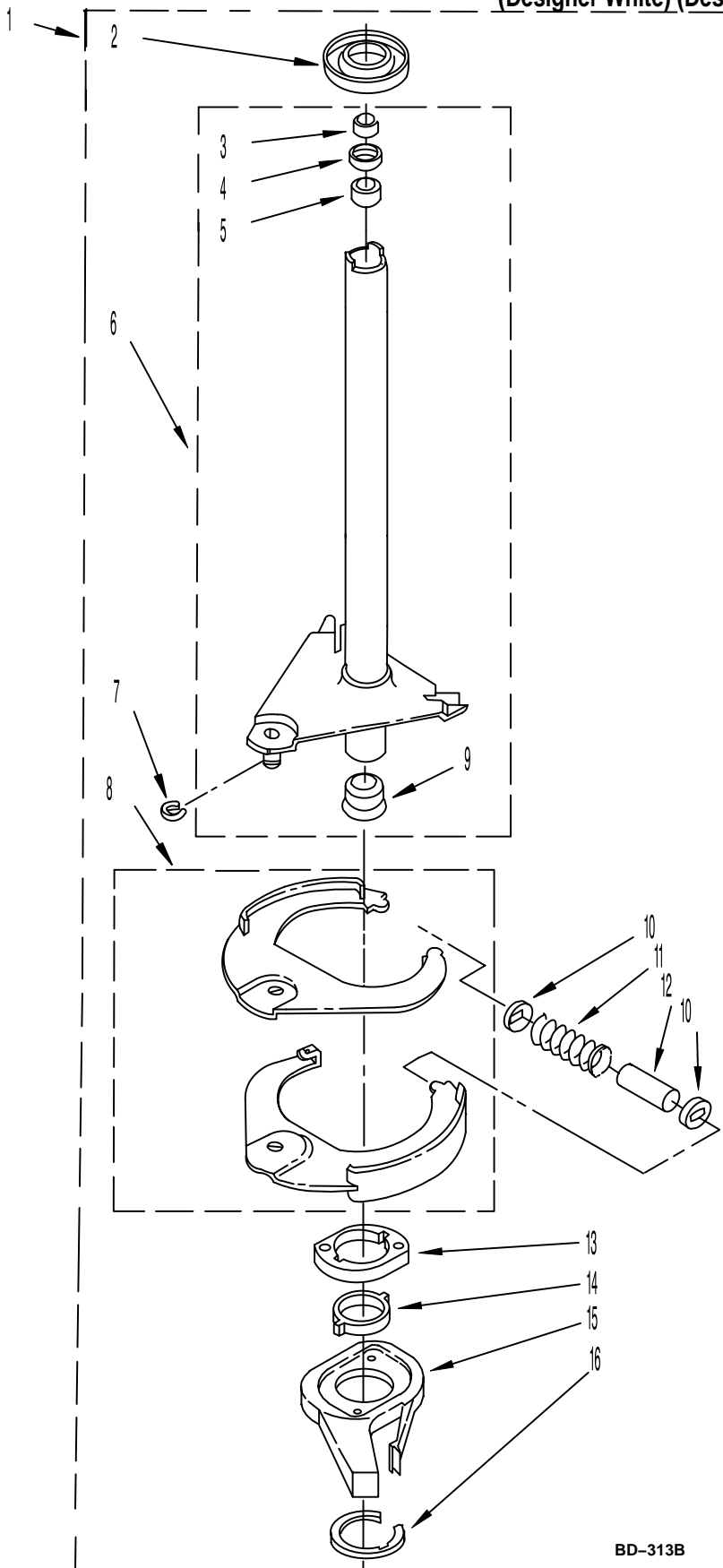

Illus. No.	Part No.	DESCRIPTION
1	387948	Brake And Drive Tube (Complete)
2	62658	Ring, Thrust
3	91939	Seal, Oil
4	356427	Seal, Drive Tube
5	356937	Spacer, Drive Tube
6	64027	Tube, Basket Drive (Includes Illus. 3, 4, 5 & 9)
7	64035	Ring, Retaining
8	64232	Brake Shoe
9	62703	"T" Bearing, Spin Tube
10	62648	Cap, Brake Spring (2)
11	63748	Spring, Brake
12	62909	Sleeve, Brake Spring
13	661516	Cam, Brake Release 63023 (Alt.) 3348288 (Alt.)
14	63022	Sleeve, Cam
15	64194	Driver, Brake Cam
16	90368	Ring, Retaining

BD-313B

BD-313B

FOR ORDERING INFORMATION REFER TO PARTS PRICE LIST



# SALES ACCESSORY PARTS

For Models: LTG5243DQ0, LTG5243DZ0  
(Designer White) (Designer Almond)

## LCK 4500

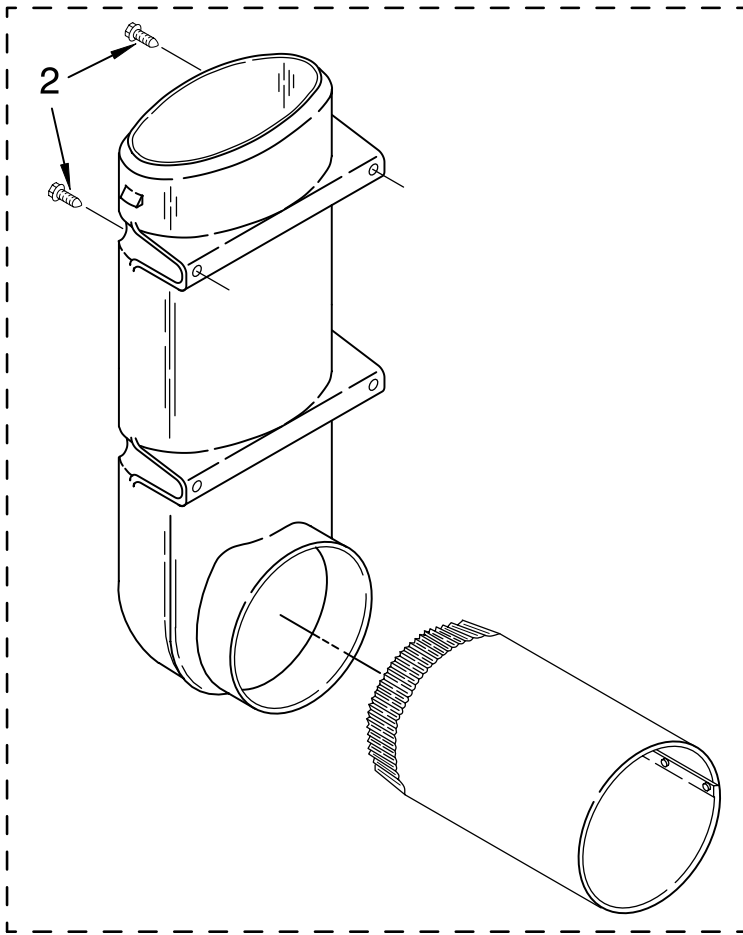

Illus. No.	Part No.	DESCRIPTION
1	694609	Exhaust Deflector Kit (Complete)
2	687128	Screw, Mounting (2) (10-16 X 1/2) (Hex Washer Head)
3	279823	Side Exhaust Extension Kit (Complete)
4	488729	Screw
5	3395536	Clip

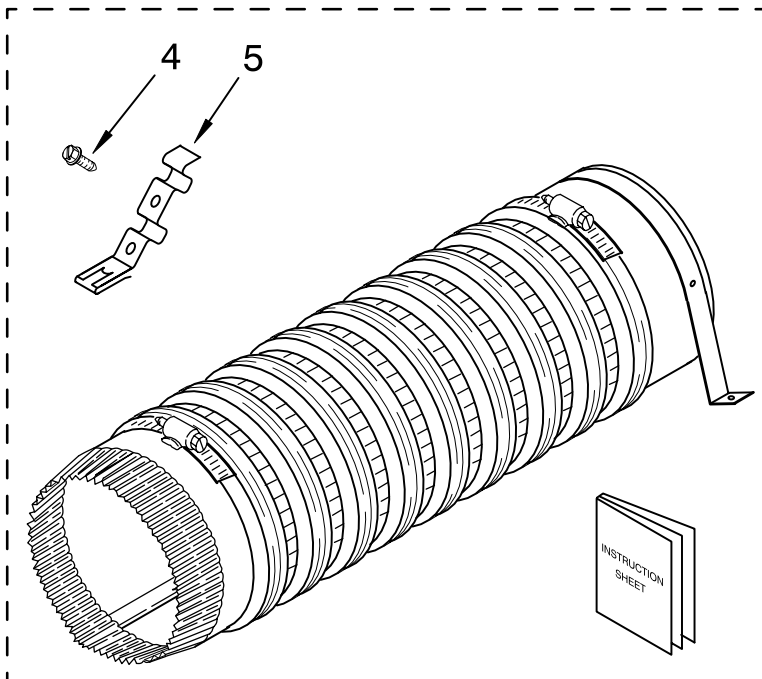

FOR ORDERING INFORMATION REFER TO PARTS PRICE LIST

# MISCELLANEOUS PARTS

For Models: LTG5243DQ0, LTG5243DZ0  
(Designer White) (Designer Almond)

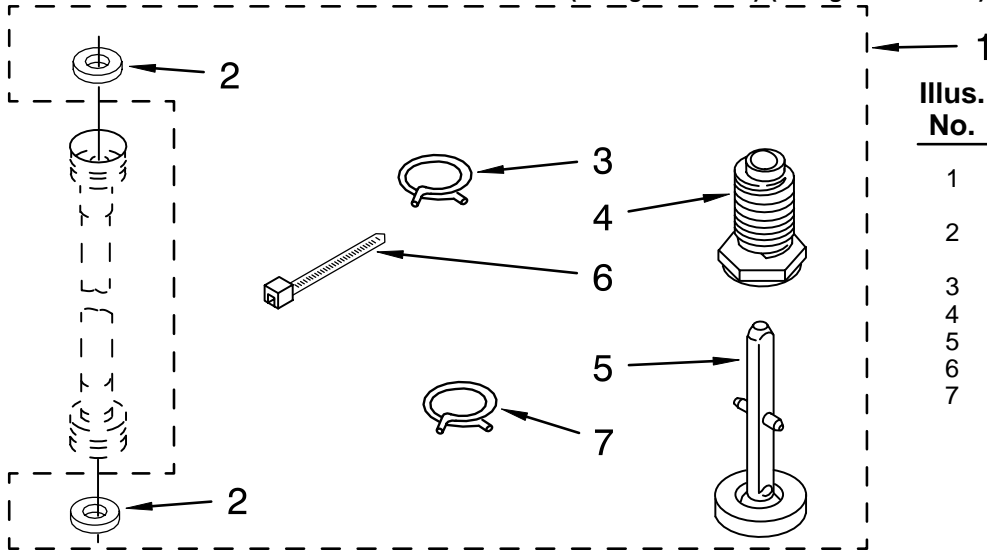

Illus. No.	Part No.	DESCRIPTION
1	3359934	Miscellaneous Parts Bag
2	16123	Washer, Inlet Hose (4)
3	370445	Clamp, Hose
4	367594	Foot, Front (2)
5	358594	Foot, Rear (2)
6	3347868	Tie, Cable
7	3357331	Clamp, Hose (Upper Drain)

# LITERATURE AND OPTIONAL PARTS

Illus. No.	Part No.	DESCRIPTION	Illus. No.	Part No.	DESCRIPTION	Illus. No.	Part No.	DESCRIPTION
<b><u>LITERATURE PARTS</u></b>			<b><u>OPTIONAL PARTS NOT INCLUDED</u></b>					
LIT3395327		Instructions, Installation	<b><u>PAINT, TOUCH-UP (1/2oz.)</u></b>			<b><u>OIL</u></b>		
LIT3401098		Guide, Use & Care	72017		White		350572	Oil, Gearcase (16 Oz.)
LIT3404405		Label, Wiring Diagram		72107	Almond	<b><u>LUBRICANT</u></b>		
LIT3397739		Tag, Energy Guide	<b><u>PAINT, PRESSURIZED SPRAY (13 oz.)</u></b>				285208	Lubricant (Use Only in Brake Shoe Assembly On Roller and Pin)
				350938	Primer, Gray	<b><u>SEALER</u></b>		
				350930	White		285195	Sealer, Gasket (.20 Fl. Oz.) (6 ml)
				350956	Almond			
			<b><u>PAINT, BULK (1 qt.)</u></b>					
				799344	White (Uncut)			
				978883	Almond (Uncut)			
			<b><u>ACCESSORY PARTS</u></b>					
					Plug, Dryer Side Panel			
				692790	White			
				692791	Almond			

FOR ORDERING INFORMATION REFER TO PARTS PRICE LIST

# 3401796 BURNER ASSEMBLY

For Models: LTG5243DQ0, LTG5243DZ0  
(Designer White) (Designer Almond)

**USE WITH TYPE 1 – NATURAL, TYPE 2 – MIXED, TYPE 3 – MANUFACTURED  
AND TYPE 4 – LIQUEFIED PROPANE AND BUTANE GASES**

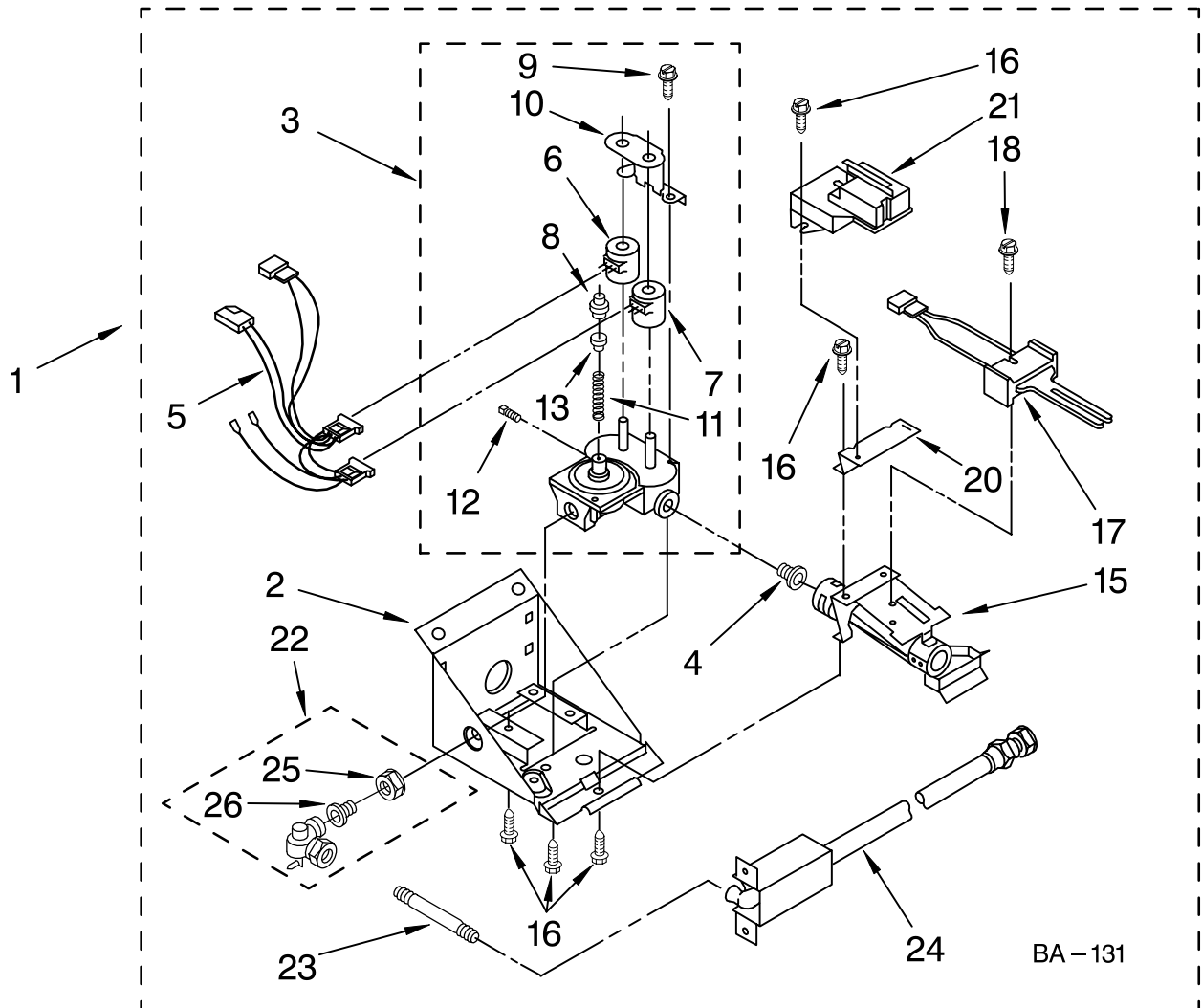

Illus. No.	Part No.	DESCRIPTION	Illus. No.	Part No.	DESCRIPTION	Illus. No.	Part No.	DESCRIPTION
1	3401796	Burner Assembly 60 Hz.	9	694421	Screw, 8-32	22	697441	Valve, Shutoff
2	697408	Base, Burner	10	694538	Bracket, Shunt	23	3388638	Nipple, Short
3	3401777	Valve, 60 Hz.	11	694422	Spring, Regulator	24	3391118	Supply Line (Gas)
4		Orifice	12	239822	Pipe, Plug	25	233076	Nut
	234822	Natural Gas	13	694423	Screw	26	3393767	Pipe
	347743	L.P. Gas	15	3392268	Burner			
5	3401849	Harness	16	3387057	Screw, 8-18 X 3/8	Following Parts Not Illustrated		
6	694539	Coil, 60 Hz. (Split)	17	686590	Ignitor			
7	694540	Coil, 60 Hz.	18	3393909	Screw and Washer 8-32 x 1	694580		Conversion Kit (Type 1, 2 & 3) to Type (4) L.P.G.
8	694424	Leak Limiter	20	697409	Bracket, Sensor			
			21	338906	Sensor, Radiant			

FOR ORDERING INFORMATION REFER TO PARTS PRICE LIST