



# Spacemaker Washers

*Safety Instructions* ..... 3, 4

*Operating Instructions*

Control Panels ..... 5

Control Settings ..... 5

Fabric Care Labels ..... 10

Features ..... 6, 7

Loading and Using the Washer ... 8, 9

*Installation Instructions* ..... 11-16

Drain Requirements ..... 14

Electrical Requirements ..... 14

Installing the Washer ..... 16

Location of Your Washer ..... 12

Preparing to Install Your Washer ... 11

Replacement Parts ..... 16

Rough-In Dimensions ..... 15

Unpacking Your Washer ..... 13

Water Supply Requirements ..... 14

*Troubleshooting Tips* ..... 17-19

*Customer Service*

Service Telephone Numbers ..... 22

Warranty for U.S. Customers ..... 20

Warranty for Canadian Customers . . . 21

**Owner's Manual & Installation Instructions**

U.S. Models:  
WSXH208  
WPXH214

Canada Models:  
WCXH208  
WCXH214



# GE & You, A Service Partnership.



## IMPORTANT!

**Staple sales slip or canceled check here.**

Proof of the original purchase date is needed to obtain service under the warranty.

Fill out the Consumer Product Registration Card.

**Two easy ways to register your appliance!**

- Through the Internet at [GEAppliances.com](http://GEAppliances.com)
- Complete and mail the enclosed Product Registration Card

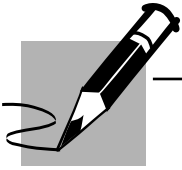

## FOR YOUR RECORDS

**Write the model and serial numbers here:**

# \_\_\_\_\_

# \_\_\_\_\_

You can find them at the top inside of the door opening.



## READ THIS MANUAL

Inside you will find many helpful hints on how to use and maintain your washer properly. Just a little preventive care on your part can save you a great deal of time and money over the life of your washer.



## IF YOU NEED SERVICE

You'll find many answers to common problems in the *Before You Call For Service* section. If you review our chart of *Troubleshooting Tips* first, you may not need to call for service at all.

If you do need service, you can relax knowing help is only a phone call away. A list of toll-free customer service numbers is included in the back section.

**OR**

Visit our Website at: [GEAppliances.com](http://GEAppliances.com)

# IMPORTANT SAFETY INFORMATION. READ ALL INSTRUCTIONS BEFORE USING.

**⚠ WARNING!** For your safety, the information in this manual must be followed to minimize the risk of fire or explosion, electric shock, or to prevent property damage, personal injury, or loss of life.

The instructions in this manual and all other literature included with this washer are not meant to cover every possible condition and situation that may occur. Good, safe practices and caution **MUST** be applied when installing, operating, and maintaining any appliance.



## WATER HEATER SAFETY

Under certain conditions hydrogen gas may be produced in a water heater that has not been used for two weeks or more. Hydrogen gas can be explosive under these circumstances.

If the hot water has not been used for two weeks or more, prevent the possibility of damage or injury by turning on all hot water faucets and allowing them to run for several minutes. Do this before using any electrical appliance which is connected to the hot water system. This simple procedure will allow any built-up hydrogen gas to escape. Since the gas is flammable, do not smoke or use an open flame or appliance during this process.



## PROPER INSTALLATION

This washer must be properly installed and located in accordance with the Installation Instructions before it is used.

- Install or store where it will not be exposed to temperatures below freezing or exposed to the weather.
- Properly ground washer to conform with all governing codes and ordinances. Follow details in Installation Instructions.



## YOUR LAUNDRY AREA

- Keep the area underneath and around your appliances free of combustible materials such as lint, paper, rags and chemicals.
- Do not leave the washer door open. An open door could entice children to hang on the door or crawl inside the washer.
- Close supervision is necessary if this appliance is used by or near children. Do not allow children to play on, with, or inside this or any other appliance.

# IMPORTANT SAFETY INFORMATION. READ ALL INSTRUCTIONS BEFORE USING.

Safety Instructions

Operating Instructions

Installation Instructions

Troubleshooting Tips

Customer Service



## WHEN USING THE WASHER

Use this appliance only for its intended purpose as described in this Owner's Manual.

- Never reach into washer while it is moving. Wait until the machine has completely stopped before opening the door.
- Do not mix chlorine bleach with ammonia or acids such as vinegar and/or rust remover. Mixing different chemicals can produce a toxic gas which may cause death.
- Do not wash or dry articles that have been cleaned in, washed in, soaked in, or spotted with combustible or explosive substances (such as wax, oil, paint, gasoline, degreasers, dry-cleaning solvents, kerosene, etc.) which may ignite or explode. Do not add these substances to the wash water. Do not use or place these substances around your washer or dryer during operation.
- The laundry process can reduce the flame retardancy of fabrics. To avoid such a result, carefully follow the garment manufacturer's wash and care instructions.
- To minimize the possibility of electric shock, unplug this appliance from the power supply or disconnect the washer at the household distribution panel by removing the fuse or switching off the circuit breaker before attempting any maintenance or cleaning.  
**NOTE:** Turning the Cycle Selector knob to an off position does **NOT** disconnect the appliance from the power supply.
- Never attempt to operate this appliance if it is damaged, malfunctioning, partially disassembled, or has missing or broken parts, including a damaged cord or plug.
- Do not slam the washer door closed or try to force the door open when locked (Door Lock light ON). This could result in damage to the washer.
- The washer is equipped with an electrical overload protector. The motor will stop if it becomes overheated. The washer will automatically restart after a cool-down period of up to 30 minutes, if the washer has not been manually turned off during this time.



## WHEN NOT IN USE

- Turn off water faucets to relieve pressure on hoses and valves and to minimize leakage if a break or rupture should occur. Check the condition of the fill hoses; they should be replaced every 5 years.
- Before discarding a washer, or removing it from service, remove the washer door to prevent children from hiding inside.
- Do not attempt to repair or replace any part of this appliance unless specifically recommended in this Owner's Manual, or in published user-repair instructions that you understand and have the skills to carry out.
- Do not tamper with controls.



**READ AND FOLLOW THIS SAFETY INFORMATION CAREFULLY.  
SAVE THESE INSTRUCTIONS**

# About the washer control panel.

You can locate your model number at the top inside of the door opening.

## Models WPXH214 and WCXH214

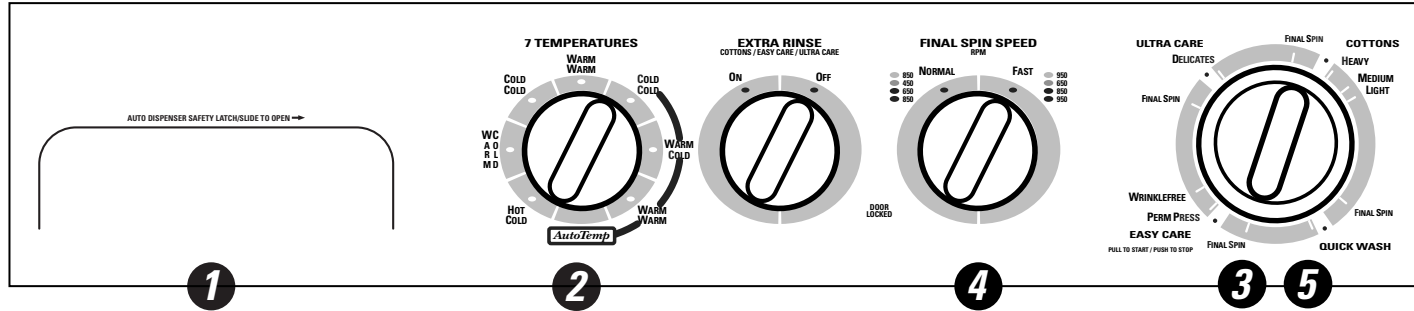

## Models WCXH208 and WSXH208

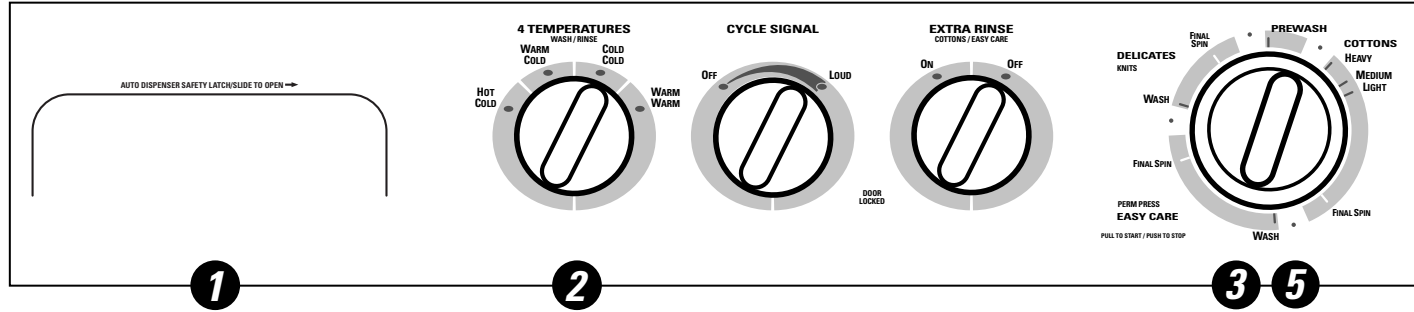

Features and appearance may vary.



## Control Settings

- 1 Automatic Dispenser and Safety Latch**  
 Safety latch slides to the right to open drawer. (Latch locks to the left on its own.) Add detergent, liquid bleach and fabric softener to this drawer.
- 2 Temperature**  
 Select the water temperature for the wash and rinse cycles. Always follow garment manufacturer's care label or instructions when laundering.
- 3 Wash Cycle**  
 The wash cycle controls the length of the washing process. The chart below will help you match the wash cycle setting with your loads.
 

<b>PREWASH</b>	For heavily soiled and protein-stained items. Follow PreWash with a complete wash cycle.
<b>COTTONS</b>	For heavy to lightly soiled cottons, household linens, work and play clothes.
<b>EASY CARE</b>	For wrinkle-free and permanent press items, and knits.
<b>DELICATES/ ULTRACARE</b>	For lightly soiled lingerie and special-care fabrics.
<b>QUICK WASH</b>	For lightly soiled items you need in a hurry.
- 4 Final Spin Speed (on some models)**  
 The Fast spin speed is for durable items.  
  
 The Normal spin speed is for delicate items like sweaters and lingerie. When using Normal spin speed, clothes will be less dry than when using Fast spin speed.
- 5** Set the desired wash cycle by pushing in cycle knob and turning clockwise.  
 Start the washer by closing the door and pulling out the cycle knob.  
 To stop the washer, push in the cycle knob and pull out to restart.
  - The washer will not operate with the door open.
  - The door will automatically lock during the entire wash cycle.

## About the washer features. *NOTE: Not all features are available on all washer models.*

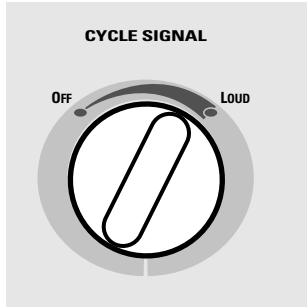

### **Cycle Signal (on some models)**

When the Cycle Signal is ON it will sound at the end of the cycle. The signal can be set at **OFF** (no sound), **LOUD** or anywhere in between.

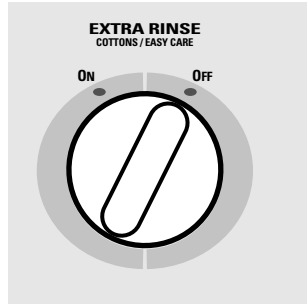

### **Extra Rinse (available on some cycles)**

Use an extra rinse when additional rinsing is desired to remove excess dirt and detergent from soiled loads.

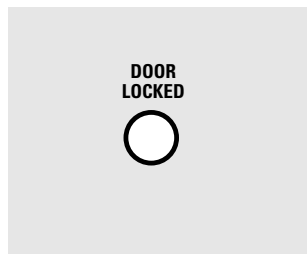

### **Door Locked Indicator Light**

The indicator light is ON and the door is locked when the cycle knob is pulled out. The light turns OFF at the end of the cycle.

### **AutoTemp (on some models)**

AUTO TEMP senses the incoming water temperature and adjusts the fill water to obtain the correct wash temperature. This feature is activated only when selecting a **COLD** or **WARM** wash temperature.

For example, if a **COLD** wash is selected, some warm water may be added to reach a temperature needed to better dissolve detergents. Often, detergents are not completely dissolved in very cold water, especially in cooler climates.

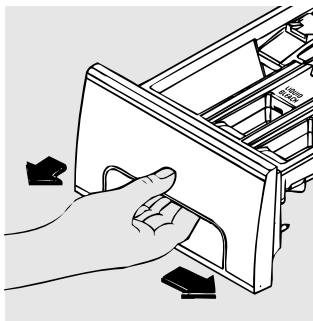

### The Dispenser Drawer

Slowly open the dispenser drawer by first sliding the safety latch to the right, then pulling the drawer out until it stops.

After adding laundry products, slowly close the dispenser drawer. Closing the drawer too quickly could result in early dispensing of the bleach and fabric softener.

You may see water in the bleach and fabric softener compartments. This is a result of the siphoning action and is part of the normal operation of the washer.



If the dispenser drawer is pulled out more than 1 1/2" when the washer is in operation, the washer will shut off. The DOOR LOCK indicator light will turn off and the door will be unlocked. Slowly close the drawer, and the washer will automatically resume operation.

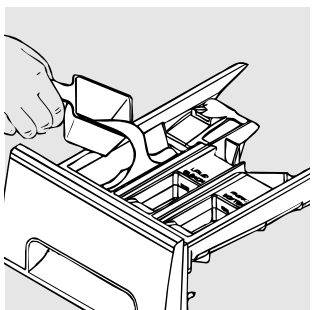

### The Detergent Compartment

- Add measured detergent to the detergent compartment of the dispenser drawer.
- Detergent is flushed from the dispenser at the beginning of the cycle. Either powdered or liquid detergent can be used.

**NOTE:** Liquid detergent will drain into the washer drum as it is added.

- Low sudsing detergent is recommended for this washer. Use the manufacturer's recommended amount.
- Detergent usage may need to be adjusted for water temperature, water hardness, size and soil level of the load. Avoid using too much detergent in your washer as it can lead to oversudsing and detergent residue being left on the clothes.

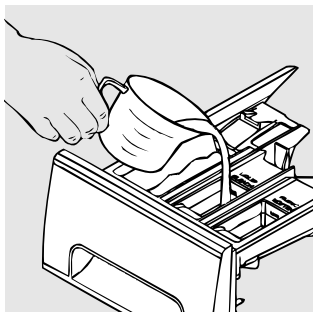

### The Liquid Bleach Compartment

If desired, measure out the recommended amount of liquid chlorine bleach, not to exceed 1/3 cup (80 ml) and pour into the center compartment labeled "LIQUID BLEACH" marked with this symbol .

Do not exceed the maximum fill line. Overfilling can cause early dispensing of the bleach which could result in damaged clothes.

**NOTE:** Do not use powdered bleach in the dispenser.

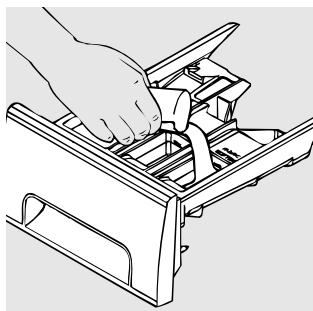

### The Fabric Softener Compartment

If desired, pour the recommended amount of liquid fabric softener into the compartment labeled "FABRIC SOFTENER" and marked with this symbol .

Dilute with water to the maximum fill line.

Do not exceed the maximum fill line. Overfilling can cause early dispensing of the fabric softener which could stain clothes.

**NOTE:** Do not pour fabric softener directly on the wash load.



## Loading and using the washer. *Always follow fabric manufacturer's care label when laundering.*



### Sorting Wash Loads

Sort laundry into loads that can be washed together.

<b>Colors</b>	<b>Soil</b>	<b>Fabric</b>	<b>Lint</b>
Whites	Heavy	Delicates	Lint Producers
Lights	Normal	Easy Care	Lint Collectors
Darks	Light	Sturdy Cottons	

- *Combine large and small items in a load. Load large items first. Large items should not be more than half the total wash load.*
- *Do not wash single items. This may cause an out-of-balance load. Add one or two similar items.*



### Loading the Washer

Wash drum may be fully loaded with loosely added items. **Do not wash fabrics containing flammable materials (waxes, cleaning fluids, etc.).**

To add items after washer has started, push in cycle knob and wait until there is no longer any water on the door window. Do not force open the locked door; open gently. Add items, close the door and pull cycle knob out to restart.



### Care and Cleaning

**Exterior:** Immediately wipe off any spills. Wipe with damp cloth. Try not to hit surface with sharp objects.

**Interior:** Dry around the washer door opening, flexible gasket and door glass. These areas should always be clean to ensure a water tight seal.

**Moving and Storage:** Ask the service technician to remove water from drain pump and hoses. Do not store the washer where it will be exposed to the weather. When moving the washer, the tub should be kept stationary by using the brackets and bolts removed during installation. See Installation Instructions in this book. If these parts are not available, they can be ordered in the United States by visiting our Website at [GEAppliances.com](http://GEAppliances.com) or by calling 800.GE.CARES. In Canada, write to Manager, Consumer Relations, Camco Inc., 1 Factory Lane, Suite 310, Moncton, N.B. E1C 9M3.

**Long Vacations:** Be sure water supply is shut off at faucets. Drain all water from hoses if weather will be below freezing.



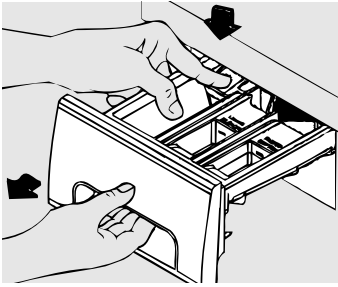

Lock tab is visible only after drawer has been pulled out

**Dispenser Drawer Area:** Detergent and fabric softener may build up in the dispenser drawer. Residue should be removed once or twice a month.

- Remove the drawer by first sliding the safety latch to the right, then pulling the drawer out until it stops. Reach back into the left rear corner of the drawer cavity and press down firmly on the lock tab, pulling out the drawer.

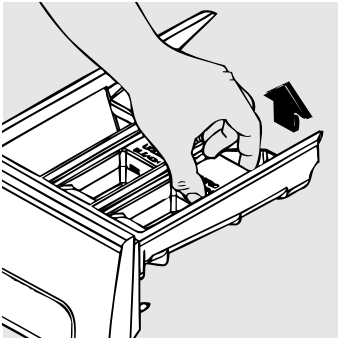

- Remove the inserts from the bleach and fabric softener compartments. Rinse the inserts and the drawer with hot water to remove traces of accumulated laundry products.

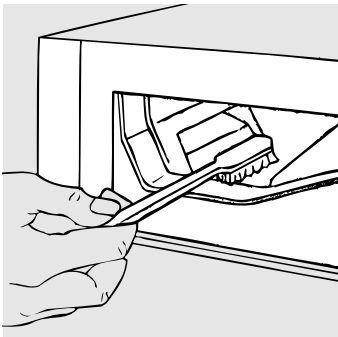

- To clean the drawer opening, use a small brush to clean the recess. Remove all residue from the upper and lower parts of the recess.
- Return the bleach and fabric softener inserts to the proper compartments. Replace the dispenser drawer and run the PREWASH or QUICK WASH cycle without any wash load in the drum.

# About the washer features.



## Fabric Care Labels

Below are fabric care label “symbols” that affect the clothing you will be laundering.

### WASH LABELS

**Machine wash cycle**

Normal	Permanent Press/ wrinkle resistant	Gentle/ delicate	Hand wash	Do not wash	Do not wring

**Water temperature**

Hot (50°C/120°F)	Warm (40°C/105°F)	Cold/cool (30°C/85°F)

### DRY LABELS

**Tumble dry**

Dry	Normal	Permanent Press/ wrinkle resistant	Gentle/ delicate	Do not tumble dry	Do not dry (used with do not wash)

**Heat setting**

High	Medium	Low	No heat/air

**Special instructions**

Line dry/ hang to dry	Drip dry	Dry flat	In the shade

### BLEACH LABELS

**Bleach symbols**

Any bleach (when needed)	Only non-chlorine bleach (when needed)	Do not bleach

# Installation Instructions

# Spacemaker Washer

Models **WCXH208**  
**WCXH214**  
**WSXH208**  
**WPXH214**

*If you have any questions, call 800.GE.CARES (800.432.2737) or visit our Website at: **GEAppliances.com***  
*In Canada, call 1.800.361.3400 or visit our Website at: **geappliances.ca***

## BEFORE YOU BEGIN

Read these instructions completely and carefully.

- **IMPORTANT** – Save these instructions for local inspector's use.
- **IMPORTANT** – Observe all governing codes and ordinances.
- **Note to Installer** – Be sure to leave these instructions with the Consumer.
- **Note to Consumer** – Keep these instructions for future reference.
- **Skill level** – Installation of this appliance requires basic mechanical and electrical skills.
- **Completion time** – 1-3 hours
- Proper installation is the responsibility of the installer.
- Product failure due to improper installation is not covered under the Warranty.

## FOR YOUR SAFETY:

### **⚠ WARNING**

- This appliance must be properly grounded and installed as described in these *Installation Instructions*.
- Do not install or store appliance in an area where it will be exposed to water/weather. See *Location of Your Washer* section.
- **NOTE: This appliance must be properly grounded, and electrical service to the washer must conform with local codes and ordinances and the latest edition of the National Electrical Code, ANSI/NFPA 70 or in Canada, CSA C22.1 Canadian Electrical Code Part 1.**

# Installation Instructions

## LOCATION OF YOUR WASHER

### Do Not Install the Washer:

1. In an area exposed to dripping water or outside weather conditions. The ambient temperature should never be below 60°F (15.6°C) for proper washer operation.
2. In an area where it will come in contact with curtains or drapes.
3. On carpet. The floor **MUST** be a hard surface with a maximum slope of 1/2" per foot (1.27 cm per 30 cm). To make sure the washer does not vibrate or move, you may have to reinforce the floor.

### IMPORTANT:

#### Minimum Installation Clearances

- When installed in alcove: Sides, Rear,  
Top = 0" (0 cm)
- When installed in closet: Sides, Rear,  
Top = 0" (0 cm), Front = 1" (2.54 cm)
- Closet door ventilation openings required:  
2 louvers each 60 square in. (387 cm<sup>2</sup>), located 3"  
(7.6 cm) from top and bottom of door

#### Undercounter Installation

If an undercounter\* installation is desired, you **MUST** install a top sheet kit, 14-A037. This kit is available through your GE retailer.

\*Custom-sized countertop is required.

#### Mobile Home Installation

Installation must conform to Standard for Mobile Homes, ANSI A119.1 and National Mobile Home Construction and Safety Standards Act of 1974 (PL93-383).

## TOOLS REQUIRED FOR WASHER INSTALLATION

- 1/4" nut driver
- 3/8" socket with ratchet
- 3/8" open-end wrench
- 7/16" socket with ratchet
- 9/16" open-end wrench
- Channel-Lock adjustable pliers
- Carpenter's level

# Installation Instructions

## UNPACKING THE WASHER

**▲ WARNING:** Destroy the carton and plastic bags after the washer is unpacked. Children might use them for play. Cartons covered with rugs, bedspreads, or plastic sheets can become airtight chambers causing suffocation. Place all materials in a garbage container or make materials inaccessible to children.

1. Cut the shipping carton along the dotted line at the base of the unit.
2. While it is in the carton, carefully lay the washer on its back side.
3. Remove the styrofoam base.
4. Carefully return the washer to an upright position and remove the carton.
5. Carefully move the washer to within 4 feet (122 cm) of the final location.
6. Remove the following from the back side of the washer:
  - 4 bolts
  - 4 yellow plastic spacers
  - 3 metal "P" clamps

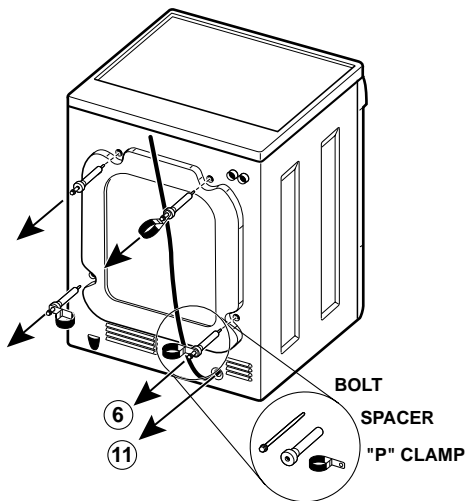

7. Remove the service panel from the front of the washer.
8. Remove the 4 nuts and 6 large washers that attach the 2 yellow shipping braces to the drum and the base. Lift up on the drum and remove the braces (a yellow ribbon surrounds the items to be removed). These braces must be removed to allow the power supply cord to be released from the shipping ring.

**NOTE:** Failure to remove the shipping braces can cause the washer to become severely unbalanced.

9. Remove the large Styrofoam block located under the drum. Lift up on the drum, tilt the base of the foam block inwards toward the rear of the washer until free, and then pull the block out.
10. Remove and discard the yellow ribbon and label from the front of the washer.

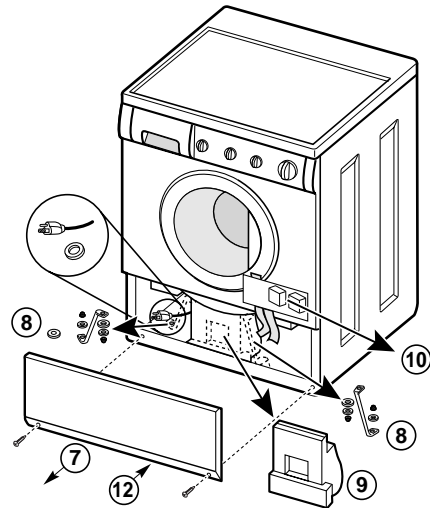

11. From the rear of the washer, carefully pull out the power supply cord through the hole in the backsheet.
12. Replace the service panel and screws.

**Save all bolts, washers, spacers, brackets, clamps, and blocks for future use.**

**NOTE:** If you must transport the washer at a later date, you must reinstall the shipping support hardware to prevent shipping damage. Keep the hardware in the plastic bag provided.

# Installation Instructions

## ELECTRICAL REQUIREMENTS

Read these instructions completely and carefully.

**CIRCUIT** – Individual, properly polarized and grounded 15-amp branch circuit fused with 15-amp time-delay fuse or circuit breaker.

**POWER SUPPLY** – 2-wire, with ground, 120-volt, single-phase, 60-Hz, Alternating Current.

**OUTLET RECEPTACLE** – Properly grounded 3-prong receptacle to be located so the power supply cord is accessible when the washer is in an installed position.

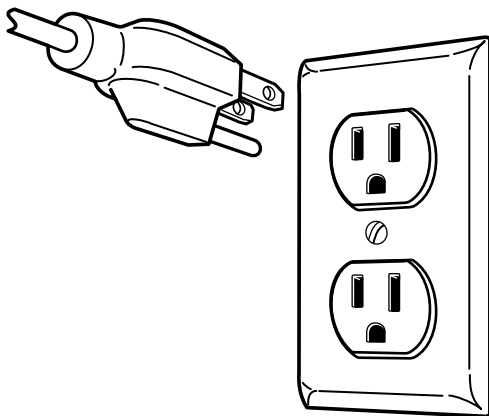

## GROUNDING REQUIREMENTS

**⚠ WARNING:** Improper connection of the equipment grounding conductor can result in a risk of electrical shock. Check with a licensed electrician if you are in doubt as to whether the appliance is properly grounded.

1. The washer **MUST** be grounded. In the event of malfunction or breakdown, grounding will reduce the risk of electrical shock by providing a path of least resistance for electrical current.
2. Since your washer is equipped with a power supply cord having an equipment-grounding conductor and a grounding plug, the plug **MUST** be plugged into an appropriate, copper-wired receptacle that is properly installed and grounded in accordance with all local codes and ordinances or in the absence of local codes, with the National Electrical Codes, ANSI/NFPA 70 (latest edition). If in doubt, call a licensed electrician. **DO NOT** cut off or alter the grounding prong on the power supply cord. In situations where a two-slot receptacle is present, it is the owner's responsibility to have a licensed electrician replace it with a **properly grounded** three-prong grounding-type receptacle.

## WATER SUPPLY REQUIREMENTS

Hot and cold water faucets **MUST** be installed within 42 inches (107 cm) of your washer's water inlet. The faucets **MUST** be 3/4" (1.9 cm) garden hose-type so inlet hoses can be connected. Water pressure **MUST** be between 10 and 120 pounds per square inch (maximum unbalanced pressure, hot vs. cold, 10 psi.) Your water department can advise you of your water pressure. The hot water temperature should be set to deliver water at 120° to 140°F (48°–60°C).

## DRAIN REQUIREMENTS

1. Drain capable of eliminating 17 gals (64.3 L) per minute.
2. A standpipe diameter of 1 1/4" (3.18 cm) minimum.
3. The standpipe height above the floor should be:  
Minimum height: 24" (61 cm)  
Maximum height: 96" (244 cm)

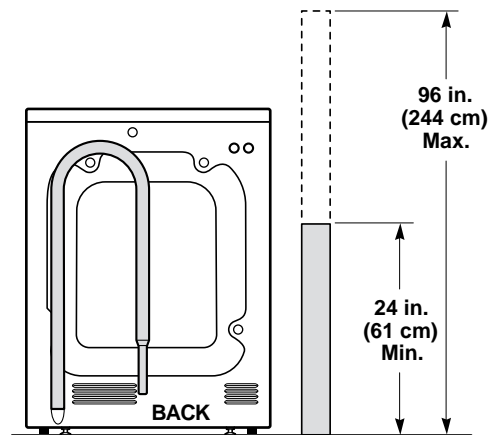

**NOTE:** The drain hose attached to the washer can reach a 58" (147 cm) high standpipe. For a higher standpipe, contact an authorized parts distributor. If the drain is less than 24" (61 cm), install a siphon break kit, available at your local hardware store.

# Installation Instructions

## ROUGH-IN DIMENSIONS

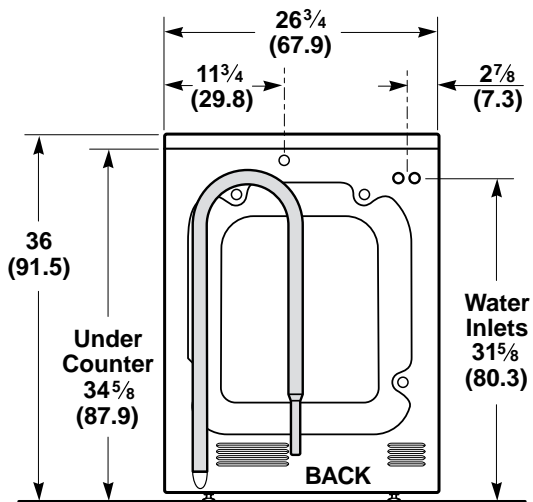
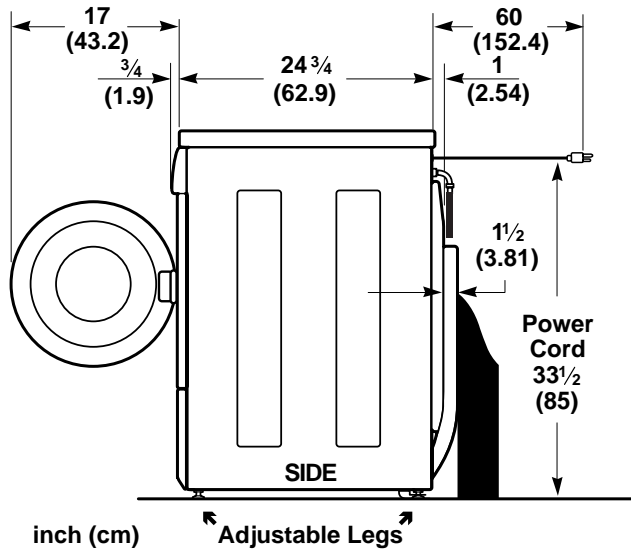



# Installation Instructions

## INSTALLING THE WASHER

1. Run some water from the hot and cold faucets to flush the water lines and remove particles that might clog up the water valve screens.



2. Remove the inlet hoses and rubber washers from the plastic bag and install the rubber washers in each end of the inlet hoses.

3. (90° elbow end)  
Carefully connect the inlet hose marked **HOT** to the outside “H” outlet of the water valve. Tighten by hand, then tighten another 2/3 turn with pliers. Carefully connect the other inlet hose to the inside “C” outlet of the water valve. Tighten by hand; then tighten another 2/3 turn with pliers. **Do not crossthread or over-tighten these connections.**

4. Connect the inlet hose ends to the **HOT** and **COLD** water faucets tightly by hand, then tighten another 2/3 turn with pliers. Turn the water on and check for leaks.

5. Carefully move the washer to its final location. Gently lift up on the front of the washer and slide back.

**NOTE:** Do not use the dispenser drawer or door to lift the washer.

6. With the washer in its final position, place a level on top of the washer (if the washer is installed under a counter, the washer should not be able to rock). Adjust the front leveling legs up or down to ensure the washer is resting solid. Turn the lock nuts on each leg up towards the base of the washer and snug with a wrench.

**NOTE:** Keep the leg extension at a minimum to prevent excessive vibration. The farther out the legs are extended, the more the washer will vibrate.

If the floor is not level or is damaged, you may have to extend the rear leveling legs. For undercounter installations, you can adjust the rear legs by removing the front service panel.

7. Form a U shape on the end of the drain hose with the hose pointed toward the drain. Place the hose in a laundry tub or standpipe and secure it with the cable tie provided in the enclosure package.

**NOTE:** If the drain hose is placed in a standpipe without forming a U shape, a siphoning action could occur. There must be an air gap around the drain hose. A snug hose fit can also cause a siphoning action.

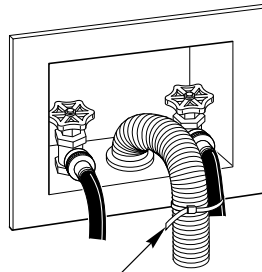

Cable Tie

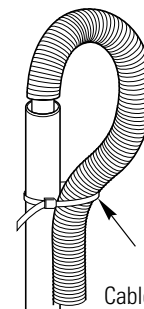

Cable Tie

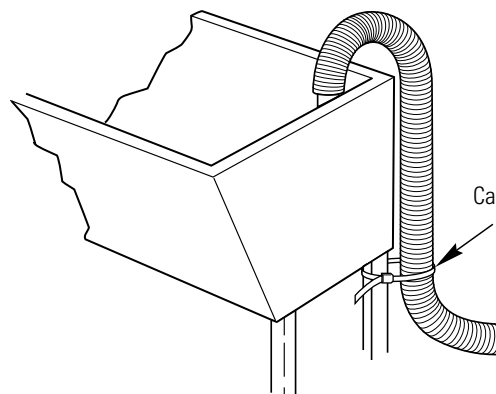

Cable Tie

8. Plug the power cord into a grounded outlet.

**NOTE:** Check to be sure the power is off at a circuit breaker/fuse box before plugging the power cord into an outlet.

9. Turn on the power at a circuit breaker/fuse box.
10. Read the rest of this Owner's Manual. It contains valuable and helpful information that will save you time and money.
11. Run the washer through a complete cycle. Check for water leaks and proper operation.
12. If your washer does not operate, please review the *Before You Call For Service* section before calling for service.
13. Place these instructions in a location near the washer for future reference.

## REPLACEMENT PARTS

If replacement parts are needed for your washer, they can be ordered in the United States by visiting our Website at [GEAppliances.com](http://GEAppliances.com) or by calling 800.GE.CARES. In Canada, write to Manager, Consumer Relations, Camco Inc., 1 Factory Lane, Suite 310, Moncton, N.B. E1C 9M3.

## Before you call for service...



### Troubleshooting Tips

Save time and money! Review the charts on the following pages first and you may not need to call for service.

<b>WATER</b>	<b>Possible Causes</b>	<b>What To Do</b>
<b>Water leaks</b>	<b>Fill hoses or drain hose is improperly connected</b>	<ul style="list-style-type: none"> <li>• Make sure hose connections are tight at washer and faucets and make sure end of drain hose is correctly inserted in and secured to drain facility.</li> </ul>
	<b>Household drain may be clogged</b>	<ul style="list-style-type: none"> <li>• Check household plumbing. You may need to call a plumber.</li> </ul>
	<b>Constant water pressure to the fill hoses at the water source</b>	<ul style="list-style-type: none"> <li>• Tighten hoses at the faucets and turn the water off after each use.</li> <li>• Check condition of the fill hoses; they should be replaced every 5 years.</li> </ul>
	<b>Oversudsing</b>	<ul style="list-style-type: none"> <li>• Use less detergent or low sudsing detergent.</li> </ul>
<b>Too many suds</b>	<b>Type of detergent</b>	<ul style="list-style-type: none"> <li>• Switch to a low-sudsing detergent and follow instructions on package.</li> </ul>
	<b>Very soft water</b>	<ul style="list-style-type: none"> <li>• Try less detergent.</li> </ul>
<b>Water won't drain</b>	<b>Drain hose is kinked or improperly connected</b>	<ul style="list-style-type: none"> <li>• Straighten drain hose and make sure washer is not sitting on it.</li> <li>• Top of drain outlet should be less than 8 ft. (2.5 m) above floor.</li> </ul>
	<b>Household drain may be clogged</b>	<ul style="list-style-type: none"> <li>• Check household plumbing. You may need to call a plumber.</li> </ul>
<b>Water temperature is incorrect</b>	<b>Control is not set properly</b>	<ul style="list-style-type: none"> <li>• Check water temperature control and adjust.</li> </ul>
	<b>Water supply is improperly connected</b>	<ul style="list-style-type: none"> <li>• Make sure hoses are connected to correct faucets.</li> </ul>
	<b>Water valve screens are stopped up</b>	<ul style="list-style-type: none"> <li>• Turn off the water source and remove the water connection hoses from the upper back of the washer. Use a brush or toothpick to clean the screens in the machine. Reconnect the hoses and turn the water back on.</li> </ul>
	<b>House water heater is not set properly</b>	<ul style="list-style-type: none"> <li>• Make sure house water heater is delivering water at 120°–140°F (48°–60°C).</li> </ul>
<b>Water does not enter washer or enters slowly</b>	<b>Water supply is turned off</b>	<ul style="list-style-type: none"> <li>• Turn on both hot and cold faucets fully.</li> </ul>

## Before you call for service...

<b>OPERATION</b>	<b>Possible Causes</b>	<b>What To Do</b>
<b>Washer pauses in cycle</b>	The washer normally pauses between washing steps	
<b>Washer won't operate</b>	<b>Washer is unplugged</b>	• Make sure cord is plugged securely into a working outlet.
	<b>Water supply is turned off</b>	• Turn both hot and cold faucets fully on.
	<b>Circuit breaker/fuse is tripped/blown</b>	• Check house circuit breakers/fuses. Replace fuses or reset breaker. Washer should have separate outlet.
	<b>Controls are not set properly</b>	• Check controls and make sure Cycle knob is pulled out.
	<b>Door is open</b>	• Close door and pull Cycle knob out.
	<b>Dispenser drawer is open</b>	• Close drawer.
	<b>Motor is overheated</b>	• Washer motor will stop if it becomes overheated. It will automatically restart after a cool down period of up to 30 minutes (if washer has not been manually turned off).
<b>Washer won't spin</b>	<b>Washer door open</b>	• Make sure door is closed.
	<b>Dispenser drawer open</b>	• Close drawer.
	<b>Load is too small</b>	• Add one or two similar items to help balance the load.

<b>NOISE</b>	<b>Possible Causes</b>	<b>What To Do</b>
<b>Washer is noisy</b>	<b>Washer is uneven</b>	• Make sure washer is level and rests firmly on the floor.
	<b>Washer load is unbalanced</b>	• Push the Cycle knob in to stop the washer, open the door and redistribute the load evenly. Close the door and restart.
	<b>High pitch jet engine sound</b>	• This is normal during the spin cycle.
	<b>Squealing sound or hot rubber odor</b>	• Washer is overloaded. Stop washer and reduce load.
	<b>Shipping bolts and foam block have not been removed</b>	• See Installation Instructions for directions to remove shipping bolts and foam block.
	<b>Rattling and clanking caused by foreign objects in tub or pump or metal fasteners hitting tub</b>	• Check drum for foreign objects. Turn items with metal fasteners inside out. Call authorized servicer to inspect pump.

<b>PERFORMANCE</b>	<b>Possible Causes</b>	<b>What To Do</b>
<b>Lint or residue on clothes</b>	<b>Incorrect sorting</b>	• Separate lint producers from lint collectors.
	<b>Washing too long</b>	• Excess wash time may create lint.
	<b>Detergent not dissolving</b>	• Try a liquid detergent.
		• Use warmer water temperature.
	<b>Overloading</b>	• Wash drum may be fully loaded with loosely added items.
<b>Incorrect use of fabric softener</b>	• Check fabric softener package for instructions and follow directions for using dispenser.	

<b>PERFORMANCE (cont.)</b>	<b>Possible Causes</b>	<b>What To Do</b>
<b>Clothes too wet</b>	<b>Load is too small</b>	<ul style="list-style-type: none"> <li>• Add one to two similar items.</li> </ul>
	<b>Load is out of balance</b>	<ul style="list-style-type: none"> <li>• Redistribute load.</li> </ul>
<b>Pilling</b>	<b>Result of normal wear on poly-cotton blends and fuzzy fabrics</b>	<ul style="list-style-type: none"> <li>• While this is not caused by the washer, you can slow the pilling process by washing garments inside out.</li> </ul>
<b>Grayed or yellowed clothes</b>	<b>Not enough detergent</b>	<ul style="list-style-type: none"> <li>• Use correct amount of detergent.</li> </ul>
	<b>Hard water</b>	<ul style="list-style-type: none"> <li>• Use hottest water safe for fabric.</li> <li>• Use a water conditioner like Calgon brand or install a water softener.</li> </ul>
	<b>Water is not hot enough</b>	<ul style="list-style-type: none"> <li>• Make sure water heater is delivering water at 120°–140°F (48°–60°C).</li> </ul>
	<b>Detergent is not dissolving</b>	<ul style="list-style-type: none"> <li>• Try a liquid detergent.</li> </ul>
	<b>Dye transfer</b>	<ul style="list-style-type: none"> <li>• Sort clothes by color. If fabric label states <i>wash separately</i>, unstable dyes may be indicated.</li> </ul>
<b>Colored spots</b>	<b>Incorrect use of fabric softener</b>	<ul style="list-style-type: none"> <li>• Check fabric softener package for instructions and follow directions for using dispenser.</li> </ul>
	<b>Dye transfer</b>	<ul style="list-style-type: none"> <li>• Sort whites or lightly colored items from dark colors.</li> <li>• Promptly remove wash load from washer.</li> </ul>
<b>Wrinkling</b>	<b>Improper sorting</b>	<ul style="list-style-type: none"> <li>• Avoid mixing heavy items (like work clothes) with light items (like blouses).</li> </ul>
	<b>Overloading</b>	<ul style="list-style-type: none"> <li>• Load your washer so clothes have enough room to move freely.</li> </ul>
	<b>Incorrect wash cycle</b>	<ul style="list-style-type: none"> <li>• Match Cycle selection to the type of fabric you are washing (especially for easy care loads).</li> </ul>
	<b>Repeated washing in water that is too hot</b>	<ul style="list-style-type: none"> <li>• Wash in warm or cold water.</li> </ul>
<b>Snags, holes, tears, rips or excessive wear</b>	<b>Pins, snaps, hooks, sharp buttons, belt buckles, zippers, and sharp objects left in pockets</b>	<ul style="list-style-type: none"> <li>• Fasten snaps, hooks, buttons, and zippers.</li> <li>• Remove loose items like pins, objects in pockets and sharp buttons.</li> <li>• Turn knits (which snag easily) inside out.</li> </ul>
	<b>Undiluted chlorine bleach</b>	<ul style="list-style-type: none"> <li>• Never add undiluted bleach to wash or allow clothes to come in contact with undiluted bleach. Follow directions for use of bleach dispenser.</li> </ul>
	<b>Chemicals like hair bleach or dye, permanent wave solution</b>	<ul style="list-style-type: none"> <li>• Rinse items that may have chemicals on them before washing.</li> </ul>

## GE Washer Warranty. (For customers in the United States)



All warranty service provided by our Factory Service Centers, or an authorized Customer Care® technician. To schedule service, on-line, 24 hours a day, visit us at [GEAppliances.com](http://GEAppliances.com), or call 800.GE.CARES (800.432.2737).

Staple your receipt here.  
Proof of the original purchase date is needed to obtain service under the warranty.

### Model WPXH214

For The Period Of:	We Will Replace:
<b>One Year</b> From the date of the original purchase	<b>Any part</b> of the washer which fails due to a defect in materials or workmanship. During this <b>full one-year warranty</b> , GE will also provide, <b>free of charge</b> , all labor and related service costs to replace the defective part.
<b>Second Year</b> From the date of the original purchase	<b>Any part</b> of the washer which fails due to a defect in materials or workmanship. During this <b>additional one-year limited warranty</b> , you will be responsible for any labor and related service costs.
<b>Third through Fifth Year</b> From the date of the original purchase	<b>The suspension strut assembly, motor or motor controller</b> , if any of these parts should fail due to a defect in materials or workmanship. GE will also replace the <b>washer door or door panel</b> , if they should rust under normal operating conditions. During this <b>additional three-year limited warranty</b> , you will be responsible for any labor and related service costs.
<b>Third through Tenth Year</b> From the date of the original purchase	<b>The outer tub or driven pulley</b> , if any of these parts should fail due to a defect in materials or workmanship. During this <b>additional eight-year limited warranty</b> , you will be responsible for any labor and related service costs.
<b>Lifetime of Product</b> From the date of the original purchase	<b>The inner wash basket</b> , if it should fail due to a defect in materials or workmanship. During this <b>product lifetime limited warranty</b> , you will be responsible for any labor and related service costs.

### Model WSXH208

For The Period Of:	We Will Replace:
<b>One Year</b> From the date of the original purchase	<b>Any part</b> of the washer which fails due to a defect in materials or workmanship. During this <b>full one-year warranty</b> , GE will also provide, <b>free of charge</b> , all labor and related service costs to replace the defective part.
<b>Second through Fifth Year</b> From the date of the original purchase	<b>The suspension strut assembly or motor</b> , if any of these parts should fail due to a defect in materials or workmanship. GE will also replace the <b>washer door or door panel</b> , if they should rust under normal operating conditions. During this <b>additional four-year limited warranty</b> , you will be responsible for any labor and related service costs.
<b>Second through Tenth Year</b> From the date of the original purchase	<b>The outer tub</b> , if it should fail due to a defect in materials or workmanship. During this <b>additional nine-year limited warranty</b> , you will be responsible for any labor and related service costs.
<b>Second through Twentieth Year</b> From the date of the original purchase	<b>The inner wash basket</b> , if it should fail due to a defect in materials or workmanship. During this <b>additional nineteen-year limited warranty</b> , you will be responsible for any labor and related service costs.

### What Is Not Covered (in the United States):

- Service trips to your home to teach you how to use the product.
- Improper installation.
- Failure of the product if it is abused, misused, or used for other than the intended purpose or used commercially.
- Replacement of house fuses or resetting of circuit breakers.
- Damage to the product caused by accident, fire, floods or acts of God.
- Incidental or consequential damage caused by possible defects with this appliance.

This warranty is extended to the original purchaser and any succeeding owner for products purchased for home use within the USA. In Alaska, the warranty excludes the cost of shipping or service calls to your home.

Some states do not allow the exclusion or limitation of incidental or consequential damages. This warranty gives you specific legal rights, and you may also have other rights which vary from state to state. To know what your legal rights are, consult your local or state consumer affairs office or your state's Attorney General.

**Warrantor: General Electric Company, Louisville, KY 40225**

# GE Washer Warranty. (For customers in Canada)



All warranty service provided by our Factory Service Centers or an authorized technician.  
For service, call 1.800.361.3400.

## Model WCXH214

For The Period Of:	We Will Replace:
<b>One Year</b> From the date of the original purchase	<b>Any part</b> of the washer which fails due to a defect in materials or workmanship. During this <b>full one-year warranty</b> , GE will also provide, <b>free of charge</b> , all labor and related service costs to replace the defective part.
<b>Second Year</b> From the date of the original purchase	<b>Any part</b> of the washer which fails due to a defect in materials or workmanship. During this <b>additional one-year limited warranty</b> , you will be responsible for any labor and related service costs.
<b>Third through Fifth Year</b> From the date of the original purchase	<b>The suspension strut assembly, motor or motor controller</b> , if any of these parts should fail due to a defect in materials or workmanship. GE will also replace the <b>washer door or door panel</b> , if they should rust under operating conditions. During this <b>additional three-year limited warranty</b> , you will be responsible for any labor and related service costs.
<b>Third through Tenth Year</b> From the date of the original purchase	<b>The outer tub or driven pulley</b> , if any of these parts should fail due to a defect in materials or workmanship. During this <b>additional eight-year limited warranty</b> , you will be responsible for any labor and related service costs.
<b>Lifetime of Product</b> From the date of the original purchase	<b>The inner wash basket</b> , if it should fail due to a defect in materials or workmanship. During this <b>product lifetime limited warranty</b> , you will be responsible for any labor and related service costs.

## Model WCXH208

For The Period Of:	We Will Replace:
<b>One Year</b> From the date of the original purchase	<b>Any part</b> of the washer which fails due to a defect in materials or workmanship. During this <b>full one-year warranty</b> , GE will also provide, <b>free of charge</b> , all labor and related service costs to replace the defective part.
<b>Second through Fifth Year</b> From the date of the original purchase	<b>The motor or motor controller</b> , if any of these parts should fail due to a defect in materials or workmanship. During this <b>additional four-year limited warranty</b> , you will be responsible for any labor and related service costs.
<b>Second through Tenth Year</b> From the date of the original purchase	<b>The driven pulley</b> , if it should fail due to a defect in materials or workmanship. During this <b>additional nine-year limited warranty</b> , you will be responsible for any labor and related service costs.
<b>Second through Twenty-fifth Year</b> From the date of the original purchase	<b>The inner wash basket</b> , if it should fail due to a defect in materials or workmanship. During this <b>additional twenty-four-year limited warranty</b> , you will be responsible for any labor and related service costs.

### What Is Not Covered (in Canada):

- Service trips to your home to teach you how to use the product.
- Improper installation.
- Failure of the product if it is abused, misused, or used for other than the intended purpose or used commercially.
- Replacement of house fuses or resetting of circuit breakers.
- Damage to the product caused by accident, fire, floods or acts of God.
- Incidental or consequential damage caused by possible defects with this appliance.

WARRANTOR IS NOT RESPONSIBLE FOR CONSEQUENTIAL DAMAGES.

Warrantor: CAMCO INC.



## Consumer Support.

---



### GE Appliances Website

In the U.S.: **GEAppliances.com**

Have a question or need assistance with your appliance? Try the GE Appliances Website 24 hours a day, any day of the year! For greater convenience and faster service, you can now download Owner's Manuals, order parts, catalogs, or even schedule service on-line. You can also "Ask Our Team of Experts™" your questions, and so much more... **In Canada: geappliances.ca**



### Schedule Service

In the U.S.: **GEAppliances.com**

Expert GE repair service is only one step away from your door. Get on-line and schedule your service at your convenience 24 hours any day of the year! Or call 800.GE.CARES (800.432.2737) during normal business hours. **In Canada, call 1.800.361.3400.**

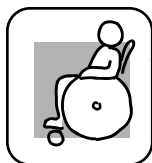

### Real Life Design Studio

In the U.S.: **GEAppliances.com**

GE supports the Universal Design concept—products, services and environments that can be used by people of all ages, sizes and capabilities. We recognize the need to design for a wide range of physical and mental abilities and impairments. For details of GE's Universal Design applications, including kitchen design ideas for people with disabilities, check out our Website today. For the hearing impaired, please call 800.TDD.GEAC (800.833.4322).

**In Canada, contact:** Manager, Consumer Relations, Camco, Inc.  
Suite 310, 1 Factory Lane  
Moncton, N.B. E1C 9M3



### Extended Warranties

In the U.S.: **GEAppliances.com**

Purchase a GE extended warranty and learn about special discounts that are available while your warranty is still in effect. You can purchase it on-line anytime, or call 800.626.2224 during normal business hours. GE Consumer Home Services will still be there after your warranty expires. **In Canada, call 1.888.261.2133.**

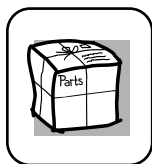

### Parts and Accessories

In the U.S.: **GEAppliances.com**

Individuals qualified to service their own appliances can have parts or accessories sent directly to their homes (VISA, MasterCard and Discover cards are accepted). Order on-line today, 24 hours every day or by phone at 800.626.2002 during normal business hours.

**Instructions contained in this manual cover procedures to be performed by any user. Other servicing generally should be referred to qualified service personnel. Caution must be exercised since improper servicing may cause unsafe operation.**

Customers **in Canada** should consult the yellow pages for the nearest Camco service center, or call 1.888.261.3055.

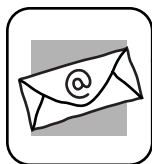

### Contact Us

In the U.S.: **GEAppliances.com**

If you are not satisfied with the service you receive from GE, contact us on our Website with all the details including your phone number, or write to:

General Manager, Customer Relations  
GE Appliances, Appliance Park  
Louisville, KY 40225

**In Canada: geappliances.ca**, or write to: Director, Consumer Relations, Camco, Inc.  
Suite 310, 1 Factory Lane  
Moncton, N.B. E1C 9M3



### Register Your Appliance

In the U.S.: **GEAppliances.com**

**Register your new appliance on-line—at your convenience!** Timely product registration will allow for enhanced communication and prompt service under the terms of your warranty, should the need arise. You may also mail in the pre-printed registration card included in the packing material. **In Canada: geappliances.ca**