

OPERATION AND PARTS MANUAL



WHITEMAN **BA-SERIES** **WALK-BEHIND TROWEL**

Revision #6 (07/06/10)

To find the latest revision of this
publication, visit our website at:
www.multiquip.com



THIS MANUAL MUST ACCOMPANY THE EQUIPMENT AT ALL TIMES.

P/N 20905



WARNING



CALIFORNIA — Proposition 65 Warning

Engine exhaust and some of its constituents, and some dust created by power sanding, sawing, grinding, drilling and other construction activities contains chemicals known to the State of California to cause cancer, birth defects and other reproductive harm.

Some examples of these chemicals are:

- Lead from lead-based paints.
- Crystalline silica from bricks.
- Cement and other masonry products.
- Arsenic and chromium from chemically treated lumber.

Your risk from these exposures varies, depending on how often you do this type of work. To reduce your exposure to these chemicals: **ALWAYS** work in a well ventilated area, and work with approved safety equipment, such as dust masks that are specially designed to filter out microscopic particles.

BA-SERIES TROWEL— TABLE OF CONTENTS

Here's How To Get Help	3
Table Of Contents	4
Parts Ordering Procedures	5
Training Checklist	6
Daily Pre-Operation Checklist	7
Safety Message Alert Symbols	8-9
Rules For Safe Operation	10-11
Operation And Safety Decals	12
Specifications (Trowel)	13
Specifications (Engines)	14
Specifications (Trowel Weights)	14
General Information	15

MQ WHITEMAN — BA-SERIES TROWEL

Controls and Components	16-17
Basic Engine	18
Assembly and Installation	19-21
Pre-Inspection	22-23
Initial Start-Up (Gasoline Engine)	24-25
Operation	26-27
Options	28-29
Maintenance	30-34
Troubleshooting (Trowel)	35-36
Troubleshooting (Engine)	37
Explanation of Codes in Remarks Column	38
Suggested Spare Parts	39
Nameplate and Decals	40-41
Standard Handle Assy.	42-43
Quick Pitch™ Handle Assy.	44-46
Thrust Bearing Kit Assy.	48-49
4 Blade Spider Assy.	50-51
Gearbox and Engine Mounts Assy.	52-54
Engines, Honda, Robin, & Briggs & Stratton	56-57
Hand Clutch Assy.	58-59
Guard Ring Assy.	60-61
Stabilizer Ring Assy.	62-63
Blades and Adjustment Fixture Assy.	64-65
Lifting Bale Assy. (Option)	66-67

HONDA GX240K1QA2 ENGINE

Air Cleaner Assy.	68-69
Camshaft Assy.	70-71
Carburetor Assy.	72-73
Control Assy.	74-75
Crankcase Cover Assy.	76-77
Crankshaft Assy.	78-79
Cylinder Barrel Assy.	80-81
Cylinder Head Assy.	82-83
Fan Cover Assy.	84-85
Flywheel Assy.	86-87
Fuel Tank Assy.	88-89
Ignition Coil Assy.	90-91
Muffler Assy.	92-93
Piston Assy.	94-95
Recoil Starter Assy.	96-97
Labels	98-99

ROBIN EH25-2 ENGINE

Crankcase Assy.	100-101
Crankshaft Assy.	102-103
Intake and Exhaust Assy.	104-105
Governor Assy.	106-107
Cooling and Starting Assy.	108-109
Fuel Tank Assy.	110-111
Carburetor Assy.	112-113
Recoil Start Assy.	114-115
Oil Sensor Assy.	116-117

Terms and Conditions of Sale — Parts	118
--	-----

NOTE

Specification and part number are subject to change without notice.

BA-SERIES TROWEL— PARTS ORDERING PROCEDURES

Ordering parts has never been easier! Choose from three easy options:

Effective:
January 1st, 2006

www.multiquip.com



Order via Internet (Dealers Only):

Order parts on-line using Multiquip's SmartEquip website!

- View Parts Diagrams
- Order Parts
- Print Specification Information



If you have an MQ Account, to obtain a Username and Password, E-mail us at: parts@multiquip.com.

To obtain an MQ Account, contact your District Sales Manager for more information.

Goto www.multiquip.com and click on

Order Parts to log in and save!

Use the **internet** and qualify for a **5% Discount** on **Standard orders** for all orders which include complete part numbers.*

Note: Discounts Are Subject To Change



Order via Fax (Dealers Only):

All customers are welcome to order parts via Fax.

Domestic (US) Customers dial:

1-800-6-PARTS-7 (800-672-7877)

Fax your order in and qualify for a **2% Discount** on **Standard orders** for all orders which include complete part numbers.*

Note: Discounts Are Subject To Change



Order via Phone: Domestic (US) Dealers Call:
1-800-427-1244

Non-Dealer Customers:

Contact your local Multiquip Dealer for parts or call 800-427-1244 for help in locating a dealer near you.



International Customers should contact their local Multiquip Representatives for Parts Ordering information.

When ordering parts, please supply:

- | | |
|---|--|
| <input type="checkbox"/> Dealer Account Number | <input type="checkbox"/> Specify Preferred Method of Shipment: |
| <input type="checkbox"/> Dealer Name and Address | <input checked="" type="checkbox"/> UPS/Fed Ex <input checked="" type="checkbox"/> DHL |
| <input type="checkbox"/> Shipping Address (if different than billing address) | <input type="checkbox"/> Priority One <input checked="" type="checkbox"/> Truck |
| <input type="checkbox"/> Return Fax Number | <input type="checkbox"/> Ground |
| <input type="checkbox"/> Applicable Model Number | <input type="checkbox"/> Next Day |
| <input type="checkbox"/> Quantity, Part Number and Description of Each Part | <input type="checkbox"/> Second/Third Day |

NOTICE

All orders are treated as *Standard Orders* and will ship the same day if received prior to 3PM PST.

WE ACCEPT ALL MAJOR CREDIT CARDS!



BA-SERIES TROWEL— TRAINING CHECKLIST

TRAINING CHECKLIST

This checklist will lists some of the minimum requirements for machine maintenance and operation. Please feel free to detach it and make copies. Use this checklist whenever a new operator is to be trained or it can be used as a review for more experienced operator's.

TRAINING CHECKLIST			
NO.	DESCRIPTION	OK?	DATE
1	Read Operator's Manual completely.		
2	Machine layout, location of components, checking of engine and gearbox fluid level.		
3	Fuel system, refueling procedure		
4	Operation of controls (machine not running).		
5	Safety controls, kill switch operation.		
6	Emergency stop procedures.		
7	Startup of machine.		
8	Maneuvering		
9	Pitching		
10	Concrete finishing techniques.		
11	Shutdown of machine.		
12	Lifting of machine (optional equipment).		
13	Machine transport and storage.		

Operator _____ Trainee _____

COMMENTS:

BA-SERIES TROWEL— DAILY PRE-OPERATION CHECKLIST

DAILY PRE-OPERATION CHECKLIST

DAILY PRE-OPERATION CHECKLIST	
1	Engine Oil Level.
2	Gearbox Fluid Level.
3	Condition of Blades.
4	Blade Pitch Operation.
5	Safety Kill Switch Operation.
6	Clutch Operation

COMMENTS:

BA-SERIES TROWEL— SAFETY MESSAGE ALERT SYMBOLS

FOR YOUR SAFETY AND THE SAFETY OF OTHERS!

Safety precautions should be followed at all times when operating this equipment. Failure to read and understand the Safety Messages and Operating Instructions could result in injury to yourself and others.

NOTE

This Owner's Manual has been developed to provide complete instructions for the safe and efficient operation of the MultiQuip BA-SERIES WALK-BEHIND TROWEL. For engine maintenance information, please refer to the engine manufacturers instructions for data relative to its safe operation.

Before using this WALK-BEHIND TROWEL, ensure that the operating individual has read and understands all instructions in this manual.

SAFETY MESSAGE ALERT SYMBOLS

The three (3) Safety Messages shown below will inform you about potential hazards that could injure you or others. The Safety Messages specifically address the level of exposure to the operator, and are preceded by one of three words: **DANGER**, **WARNING**, or **CAUTION**.



DANGER: You **WILL** be **KILLED** or **SERIOUSLY** injured if you **DO NOT** follow directions.



WARNING: You **CAN** be **KILLED** or **SERIOUSLY** injured if you **DO NOT** follow directions.



CAUTION: You **CAN** be injured if you **DO NOT** follow directions.

Potential hazards associated with B-Series trowel operation will be referenced with "**Hazard Symbols**" which appear throughout this manual, and will be referenced in conjunction with Safety "**Message Alert Symbols**".

HAZARD SYMBOLS



Lethal Exhaust Gases



Engine exhaust gases contain poisonous carbon monoxide. This gas is colorless and odorless, and can cause death if inhaled. **NEVER** operate this equipment in a confined area or enclosed structure that does not provide ample free flow air.



Explosive Fuel



Gasoline is extremely flammable, and its vapors can cause an explosion if ignited. **DO NOT** start the engine near spilled fuel or combustible fluids. **DO NOT** fill the fuel tank while the engine is running or hot. **DO NOT** overfill tank, since spilled fuel could ignite if it comes into contact with hot engine parts or sparks from the ignition system. Store fuel in approved containers, in well-ventilated areas and away from sparks and flames. **NEVER** use fuel as a cleaning agent.



Burn Hazards



Engine components can generate extreme heat. To prevent burns, **DO NOT** touch these areas while the engine is running or immediately after operations. **NEVER** operate the engine with heat shields or heat guards removed.



Rotating Parts



NEVER operate equipment with covers, or guards removed. Keep fingers, **hands**, **hair** and **clothing** away from all moving parts to prevent injury.

BA-SERIES TROWEL— SAFETY MESSAGE ALERT SYMBOLS



Accidental Starting



OFF **ALWAYS** place the engine ON/OFF switch in the **OFF** position, when the trowel is not in use.



Respiratory Hazard



ALWAYS wear approved respiratory protection.



Over Speed Conditions



NEVER tamper with the factory settings of the engine governor or settings. Personal injury and damage to the engine or equipment can result if operating in speed ranges above maximum allowable.



Sight and Hearing hazard

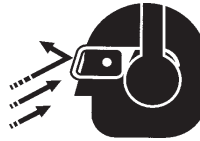

ALWAYS wear approved eye and hearing protection.

NOTE

This *walk-behind trowel*, other property, or the surrounding environment could be damaged if you do not follow instructions.



Equipment Damage Messages

Other important messages are provided throughout this manual to help prevent damage to your trowel, other property, or the surrounding environment.

BA-SERIES TROWEL— RULES FOR SAFE OPERATION

CAUTION:



Failure to follow instructions in this manual may lead to serious injury or even death! This equipment is to be operated by trained and qualified personnel only! This equipment is for industrial use only.

The following safety guidelines should always be used when operating the BA-Series walk-behind trowel.

SAFETY

- **DO NOT** operate or service this equipment before reading this entire manual.



- This equipment should not be operated by persons under 18 years of age.
- **NEVER** operate the trowel without proper protective clothing, shatterproof glasses, steel-toed boots and other protective devices required by the job.



- **NEVER** operate this equipment when not feeling well due to fatigue, illness or taking medicine.



- **NEVER** operate the trowel under the influence of drugs or alcohol.



- **NEVER** use accessories or attachments, which are not recommended by Multiquip for this equipment. Damage to the equipment and/or injury to user may result.
- Manufacture does not assume responsibility for any accident due to equipment modifications.
- Whenever necessary, replace nameplate, operation and safety decals when they become difficult read.
- **ALWAYS** check the trowel for loosened threads or bolts before starting.

- **NEVER** touch the hot exhaust manifold, muffler or cylinder. Allow these parts to cool before servicing the trowel.

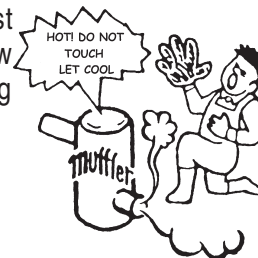

- **High Temperatures** – Allow the engine to cool before adding fuel or performing service and maintenance functions. Contact with **hot!** components can cause serious burns.

- The engine of this trowel requires an adequate free flow of cooling air. **NEVER** operate the trowel (except electric models)

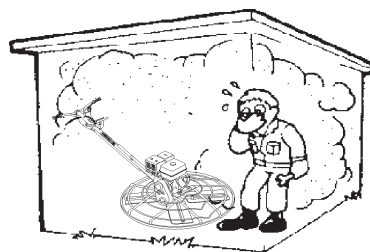

in any enclosed or narrow area where free flow of the air is restricted. If the air flow is restricted it will cause serious damage to the trowel's engine and may cause injury to people. Remember the trowel's engine gives off **DEADLY** carbon monoxide gas.

- **ALWAYS** refuel in a well-ventilated area, away from sparks and open flames.

- **ALWAYS** use extreme caution when working with **flammable** liquids. When refueling, **stop the engine** and allow it to cool.

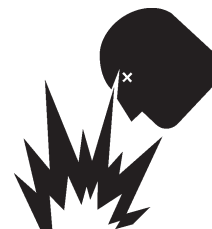

- **NEVER** smoke around or near the machine. Fire or explosion could result from **fuel vapors**, or if fuel is spilled on a **hot!** engine.



- **NEVER** operate the trowel in an explosive atmosphere or near combustible materials. An explosion or fire could result causing severe **bodily harm or even death**.

- Topping-off to filler port is dangerous, as it tends to spill fuel.

BA-SERIES TROWEL— RULES FOR SAFE OPERATION

- **DO NOT** operate this trowel unless all guards and safety devices are attached and in place. See Pages 16 and 17.
- **ALWAYS** use proper lifting techniques when moving the trowel.
- **ALWAYS** check to make sure that the operating area is clear before starting the engine.
- **ALWAYS** test the safety *kill switch* devices before operating the trowel.
- **NEVER** place your *feet* or *hands* inside the guard rings while starting or operating this equipment.
- **AVOID** wearing jewelry or loose fitting clothing that may snag on the controls or moving parts, this can cause a serious injury.
- **ALWAYS** keep clear of *rotating* or *moving parts* while operating the trowel.
- **NEVER** leave the machine *unattended* while running.
- **Moving Parts** – Shut down the engine before performing service or maintenance functions. Contact with moving parts can cause serious injury.
- Keep the trowel in proper running condition.
- Make sure that there is no buildup of concrete, grease, oil or debris on the trowel.
- Fix damage to the trowel immediately and always replace broken parts.
- Dispose of hazardous waste properly. Examples of potentially hazardous waste are used *motor oil*, *fuel* and *fuel filters*.
- **High Temperatures** – Allow the machine and engine to *cool* before adding fuel or performing service and maintenance functions. Contact with *hot!* components can cause serious burns.

CAUTION

Emergencies



- **ALWAYS** know the location of the nearest *fire extinguisher* and *first aid kit*. Know the location of the nearest telephone. Also know the phone numbers of the nearest *ambulance*, *doctor* and *fire department*. This information will be invaluable in the case of an *emergency*.

Maintenance Safety

- Disconnect the spark plug wires before attempting any type of service.
- Securely support any machine components that must be raised.
- **NEVER** lubricate components or attempt service on a running machine.
- **DO NOT** use food or plastic containers to dispose of hazardous waste.
- **DO NOT** pour *waste*, *oil* or *fuel* directly onto the ground, down a drain or into any water source.

BA-SERIES TROWEL— OPERATION AND SAFETY DECALS

Machine Safety Decals

The BA-Series walk-behind trowel is equipped with a number of safety decals. These decals are provided for operator safety and maintenance information. Figure 1 below illustrates these decals as they appear on the machine. Should any of these decals become unreadable, replacements can be obtained from your dealer.

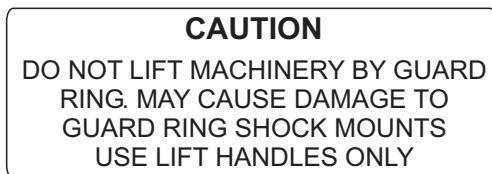

P/N 1261



P/N 20526



P/N 1940



P/N 20527



P/N 1736

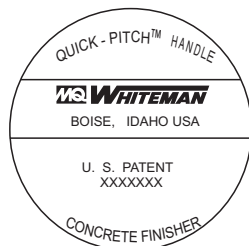

P/N 1758



P/N 12405



P/N 1492



P/N 1848



P/N 1735



P/N 2938



P/N1499

	Symbol indicates that it is mandatory to wear safety glasses, safety helmet and ear protection. P/N 11247 (Part of decal kit 12620)		CONTACT MULTIQUIP SERVICE DEPT.
	Symbol indicates that it is mandatory to wear gloves. P/N 11247 (Part of decal kit 12620)		Symbol indicates that it is mandatory to wear safety shoes, with extra protection (steel toed). P/N 11247 (Part of decal kit 12620)
	Radiating heat symbol. Symbol indicates equipment is hot. P/N 11246 (Part of decal kit 12620)		This is the symbol for belt drive. P/N 11246 (Part of decal kit 12620)
	Symbol for examining or checking of the machine. Mostly used for maintenance. Check lubrication oil in gearbox. P/N 11246 (Part of decal kit 12620)		This is the symbol for gear drive. P/N 11246 (Part of decal kit 12620)

Figure 1. BA-Series Trowel Decals

BA-SERIES TROWEL— SPECIFICATIONS (TROWEL)

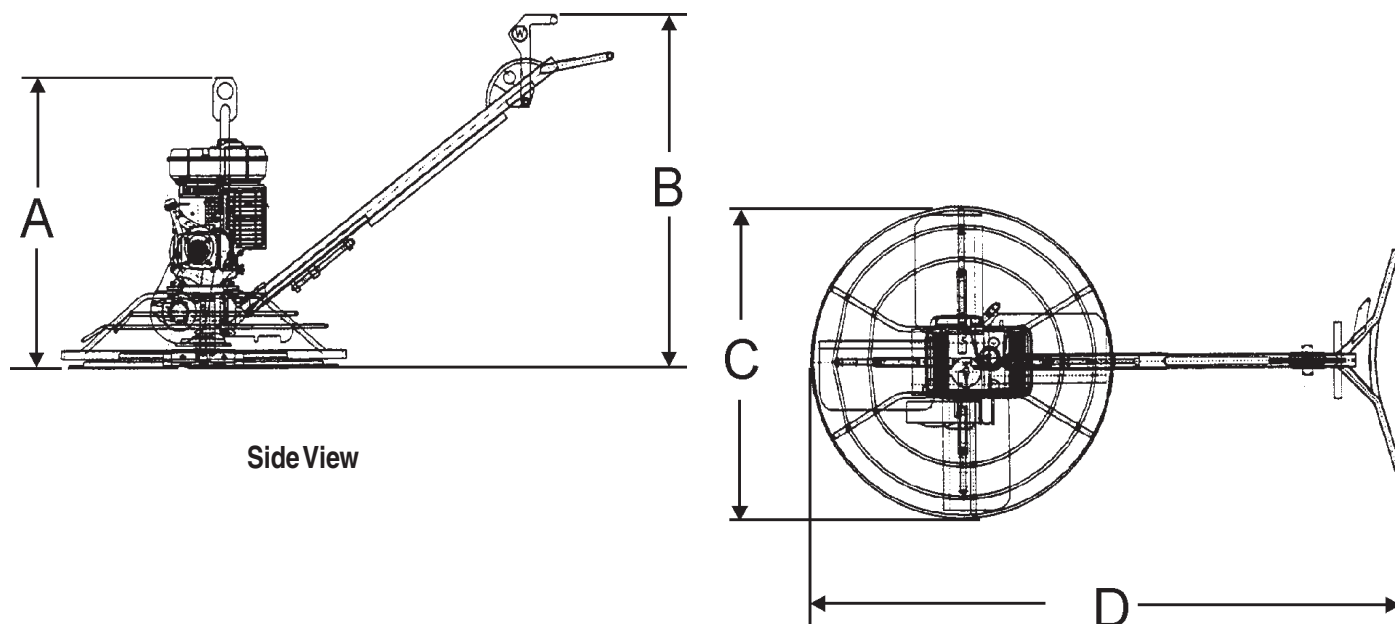

Figure 2. BA-Series Trowel Dimensions

Table 1. BA-Series Trowel Specifications	
A- Height (Lifting Hook)	34.5 in (876.2 mm)
B- Height Engagement Lever)	41.1 in (1,044.2 mm)
C-Width	46.0 (1,168.4 mm)
D-Length	75.2 (1,910.1 mm)
Weight – Operating	See Table 3
Sound Pressure	97 db
Vibration	2.5g (24.5 m/s ²)
Ring Diameter	46 in (117 cm)
Number of Blades	3 or 4
Blade Tip Speed – FPM (m/s)	1,478 fpm (7.5 m/s)
Rotor – RPM (Gasoline)	60 to 125
Path Width – in. (cm)	48 (233)

NOTE:

1. Sound pressure is a weighted measure. Measured at the operators ear position while the walk-behind trowel is operating at full throttle on concrete in a manner most often experienced in “*normal*” circumstances. Sound pressure may vary depending upon the condition of the concrete. Hearing protection is always recommended.
2. The vibration level indicated is the maximum RMS (Root Mean Square) value obtained at the handle grip while operating the walk-behind trowel on curing concrete in a manner most often experienced in “*normal*” circumstances. Values were obtained from all three axes of motion. The values shown represent the maximum RMS value from these measurements.

BA-SERIES TROWEL— SPECIFICATIONS (ENGINES)

Table 2. Specifications (Engines & Electric Motor)

	Model	HONDA GX240K1QA2	ROBIN EH-25-2	Electric Motor
Engine/Electric Motor	Type	Air-cooled 4 stroke, Single Cylinder, OHV, Horizontal Shaft Gasoline Engine	Air-cooled 4 stroke, Single Cylinder, OHV, Horizontal Shaft Gasoline Engine	N/A
	Bore X Stroke	2.90 in. X 2.30 in. (73 mm x 58 mm)	2.95 in. X 2.24 in. (75 mm x 57 mm)	N/A
	Displacement	14.81 cc	15.31 cc	N/A
	Max Output	8.0 H.P./3600 R.P.M.	8.5 H.P./4000 R.P.M.	2.0 HP
	Fuel Tank Capacity	Approx. 1.59 U.S. Gallons (6 Liters)	Approx. 1.59 U.S. Gallons (6 Liters)	N/A
	Fuel	Unleaded Gasoline	Unleaded Gasoline	N/A
	Lube Oil Capacity	2-1/3 pints	2 pints	N/A
	Speed Control Method	Centrifugal Fly-weight Type	Centrifugal Fly-weight Type	N/A
	Starting Method	Recoil Start	Recoil Start	N/A
	Input Voltage	N/A	N/A	115/230 VAC Single Phase
	Dimension (L x W x H)	14.0 x 16.9 X 16.1 in. (355 X 430 X 410 mm)	14.40 x 16.20 X 17.32 in. (366 X 412 X 440 mm)	TBD
Dry Net Weight	55.1 lbs (25 Kg.)	50.7 lbs (23 Kg.)	TBD	

Table 3. Specifications (Trowel Weights)

MODEL	POWER SOURCE	OPERATING WEIGHT	SHIPPING WEIGHT
B-3-8H	8 HP Honda	237 lbs. (107 kg.)	286 lbs. (130 kg.)
B-4-8BS	8 HP Briggs and Stratton	228 lbs. (103 kg.)	278 lbs. (126 kg.)
B-4-7R	7.5 HP Robin	237 lbs. (107 kg.)	287 lbs. (130 kg.)
B-4-7RM	7.5 HP Robin, Manual Clutch	237 lbs. (107 kg.)	287 lbs. (130 kg.)
B-4-8H	8.0 HP Honda	242 lbs. (110 kg.)	292 lbs. (132 kg.)
B-4-8HM	8.0 HP Honda, Manual Clutch	242 lbs. (110 kg.)	292 lbs. (132 kg.)

BA-SERIES TROWEL—GENERAL INFORMATION

BA-Series Walk-Behind Trowel Familiarization

This walk-behind trowel is designed for the **floating** and **finishing** of concrete slabs.

Take a walk around the trowel. Take notice of all the major components (see Figure 3, pages 16 and 17) like the engine, blades, quick pitch control, air cleaner, centrifugal stop switch etc. Check that there is always oil in the engine.

Read all the safety instructions carefully. Safety instructions will be found throughout this manual and on the trowel. Keep all safety information in good, readable condition. Operators should be well trained on the operation and maintenance of the trowel.

Before using your trowel, test it on a flat watered down section of finished concrete that is free of any debris and other objects.

This trial test run will increase your confidence in using the trowel and at the same time it will familiarize you with the trowel's controls. In addition you will understand how the trowel handles under actual conditions.

Engines

This trowel is available with either an 8.0 HP **HONDA**, 8.5 HP **ROBIN**, or a 8.0 HP **Briggs and Stratton** gasoline engine. Refer to the engine owner's manual for instructions regarding the operation and maintenance of your engine. The engine manual is included with your trowel at the time of shipment from Whiteman. Please contact your nearest Multiquip Dealer for a replacement should the original manual disappear.

Drive System

Power is transferred from the engine to the gearbox input shaft via a V-belt or pulley drive system. The pulley engages using either a centrifugal or manual clutch. See page 23.

Gearbox

The **gearbox** is located beneath the engine and transfers power to the **rotor** or **spider** assembly. The gearbox controls the rotational speed of the trowel and is equipped with two shafts (input and output).

Spider

The vertical output shaft of the gearbox connects to a cast hub called the **spider**. The spider has either 3 or 4 arms that extend outward that are used for attachment of blades or other accessories. Remember as the gearbox output shaft rotates so does the spider assembly.

Blades

The blades of the trowel finish the concrete as they are rotated around the surface. Blades are classified as **combination** (8 inches wide), **float** (10 or 8 inches wide), and **finish** (6 inches wide). This trowel comes equipped with either **three** or four **blades** per rotor equally spaced in a radial pattern and attached to vertical rotating shaft by means of a **spider assembly**.

Centrifugal Stop Switch

In the event of a trowel runaway condition (operator releases the handle), a **centrifugal stop switch** or **manual clutch** depending on which trowel you have, will stop the engine and bring the trowel to a halt.

CAUTION



NEVER attempt to **lift** the trowel by yourself. **ALWAYS** get the assistance of another person to help lift the trowel or use a crane or lifting device to move the trowel.

Moving the BA-Series Walk-Behind Trowel

This walk-behind trowel is designed to be moved and handled in several ways. The easiest way to lift the trowel is to use the **auxiliary lifting tube** that is attached to the main handle. See page 24, Figure 21. When using the auxiliary tube, always use **two persons** to lift the trowel.

Some models have a **lifting bale** (option) installed. A strap or chain can be attached to the lifting bale, allowing a forklift or crane to lift the trowel up onto a slab of concrete. Use a lifting device of adequate lifting capacity to lift the trowel.

Training

For proper training, please use the "**TRAINING CHECKLIST**" located in the front of this manual (Page 6). This checklist will provide an outline for an experienced operator to provide training to a new operator.

BA-SERIES TROWEL— CONTROLS AND COMPONENTS

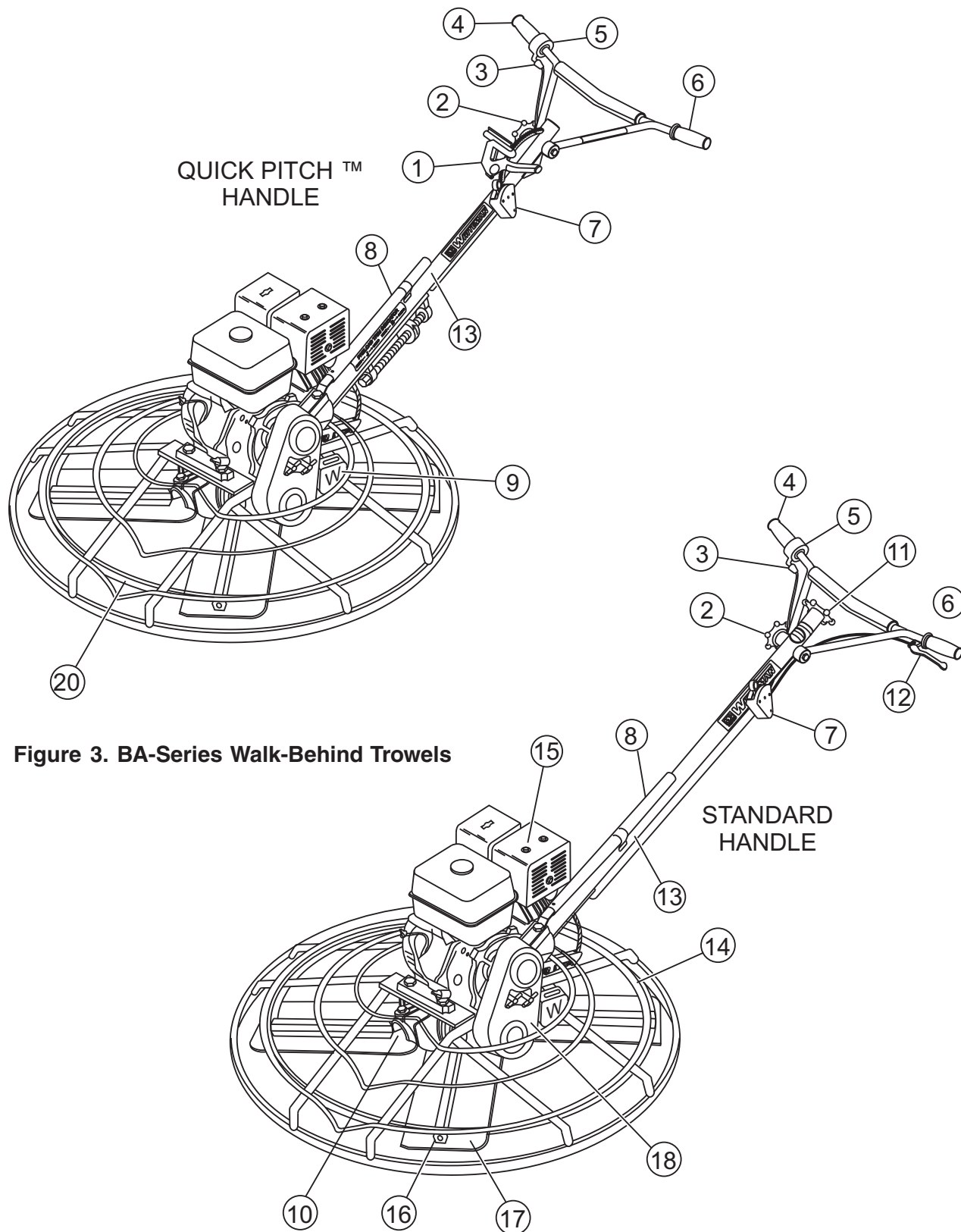

Figure 3. BA-Series Walk-Behind Trowels

BA-SERIES TROWEL— CONTROLS AND COMPONENTS

Figure 3 shows the location of the basic controls or components, for the BA-Series trowel. Listed below is a brief explanation of each control or component

1. **Quick Pitch™ Control Handle** – To adjust the pitch of the blades, grasp the handle then squeeze and either move the handle forward or backward to achieve the desired blade pitch.
2. **Handlebar Adjuster** – Change the angle/height of the handle bars by loosening star wheel, adjust handlebars to desired location, tighten starwheel firmly to hold handlebars in that position.
3. **Hand Grip/Handle Bar** – When operating the trowel, place both hands on each grip to maneuver the trowel. Replace hand grips when they become worn or damaged.
4. **Throttle Control Grip** – Controls the speed of the engine. Rotate the hand grip away from the operator to increase engine speed (high), toward the operator to decrease engine speed (low).
5. **Throttle** – Controls engine speed when throttle control grip is rotated.
6. **Hand Grip/Handle Bar** – When operating the trowel, place both hands on each grip to maneuver the trowel. Replace hand grips when they become worn or damaged.
7. **Centrifugal Kill Switch** – In the event the operator loses control of the trowel, this switch will shut-down the engine.
8. **Auxiliary Lifting Tube** - Use this tube to lift the trowel onto a slab. Tube is to be inserted into socket located in front of the gearbox.
9. **Weights** – The trowel may be equipped with two 10 lbs. weights. The weights may be removed to reduce the operating weight of the trowel.
10. **Trowel Lifting Point** – Insert the auxiliary lifting tube here. See Figure 21.
11. **Pitch Control (standard models)** - Turn this "Star Wheel" clockwise for increase blade pitch, and counter-clockwise for decrease blade pitch.
12. **Clutch Lever** - Clutch engagement lever. When this lever is engaged, the blades will begin to rotate. May be used with either Quick Pitch™ or Standard handle.
13. **Main Tube** - When disassembling components inside the tube exercise extreme **CAUTION!** Tube is spring-loaded, severe injury could result if not disassembled correctly.
14. **Guard Ring- NEVER!** put hands or feet inside guard ring.
15. **Engine** – This trowel uses Honda, Robin and Briggs and Stratton type gasoline engines.
16. **Trowel Arm** – **NEVER** operate the trowel with a bent, broken or out of adjustment trowel arm. If the blades show uneven wear patterns or some blades wear out faster than others, the trowel arm may need to be adjusted. Use the trowel arm adjustment tool P/N 1817 to adjust the trowel arms.
17. **Blades** – This trowel is equipped with combination blades. These blades are versatile and should take care of most troweling needs. In addition float discs can be attached to the trowel arms that will allow the trowel to float on "wet" concrete.
18. **V-Belt Cover** – Remove this cover to gain access to the V-belt. **NEVER** operate the trowel with this cover removed.
20. **Stabilizer Ring** – Reduces trowel arm vibration. Helps stabilize trowel arm.

BA-SERIES TROWEL— BASIC ENGINE

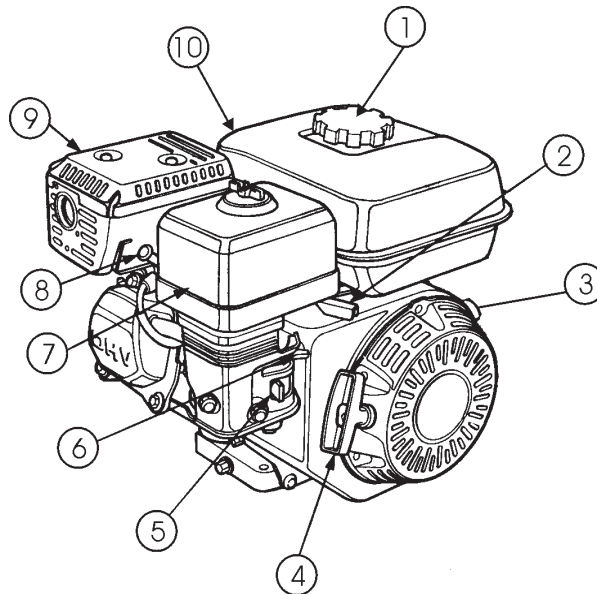

HONDA engine shown.

Figure 4. Engine Controls and Components

INITIAL SERVICING

The engine (Figure 4) must be checked for proper lubrication and filled with fuel prior to operation. Refer to the manufacturer's engine manual for instructions & details of operation and servicing. The engine shown above is a **HONDA** engine, operation for other types of engines may vary somewhat.

1. **Fuel Filler Cap** – Remove this cap to add unleaded gasoline to the fuel tank. Make sure cap is tightened securely. **DO NOT** over fill.



DANGER

Adding fuel to the tank should be done only when the engine is stopped and has had an opportunity to cool down. In the event of a fuel spill, **DO NOT** attempt to start the engine until the fuel residue has been completely wiped up, and the area surrounding the engine is dry.

2. **Throttle Lever** – Used to adjust engine RPM speed (lever advanced forward **SLOW**, lever back toward operator **FAST**).
3. **Engine ON/OFF Switch** – ON position permits engine starting, OFF position stops engine operations.
4. **Recoil Starter (pull rope)** – Manual-starting method. Pull the starter grip until resistance is felt, then pull briskly and smoothly.

5. **Fuel Valve Lever** – **OPEN** to let fuel flow, **CLOSE** to stop the flow of fuel.
6. **Choke Lever** – Used in the starting of a cold engine, or in cold weather conditions. The choke enriches the fuel mixture.
7. **Air Cleaner** – Prevents dirt and other debris from entering the fuel system. Remove wing-nut on top of air filter canister to gain access to filter element.

NOTE

Operating the engine without an air filter, with a damaged air filter, or a filter in need of replacement will allow dirt to enter the engine, causing rapid engine wear.

8. **Spark Plug** – Provides spark to the ignition system. Set spark plug gap to 0.6 - 0.7 mm (0.028 - 0.031 inch) Clean spark plug once a week.
9. **Muffler** – Used to reduce noise and emissions.



WARNING

Engine components can generate extreme heat. To prevent burns, **DO NOT** touch these areas while the engine is running or immediately after operating. **NEVER** operate the engine with the muffler removed.

10. **Fuel Tank** – Holds unleaded gasoline. For additional information refer to engine owner's manual.

BA-SERIES TROWEL — ASSEMBLY AND INSTALLATION

Assembly and Installation

Before the trowel can be put into operation there are some components that must be installed before the trowel can be used. This section provided general instructions on how to install those components. Instruction sheet P/N 20485 provides further details for the handle assembly.

Handle Tube Installation (All Models)

1. Install the **handle tube** to the gearbox as shown in (Figure 5). The mounting hardware should be contained in the shipping container.

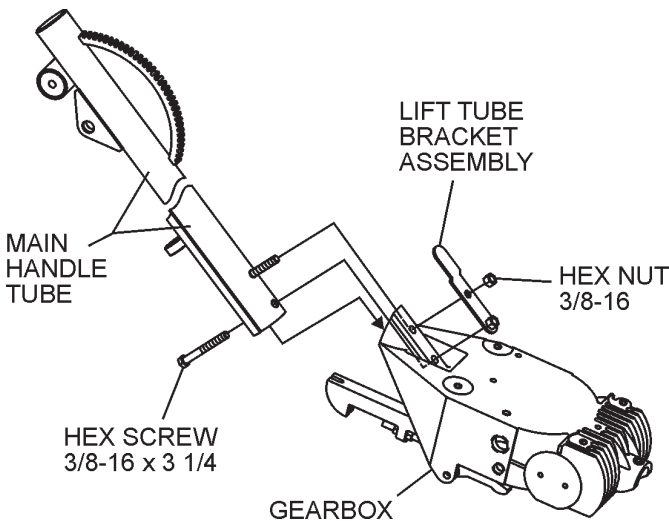

Figure 5. Handle Tube Installation

2. On Quick-Pitch™ models, pivot the **T-handle** back (full pitch) (Figure 6). This will relax the spring inside the handle tube. On either model, spread the handle bar ends just enough to engage the teeth on the handle tube. Attach the hand wheel assembly, position handlebar to desired location, and tighten hand wheel firmly.

CAUTION



The Quick-Pitch™ handle is spring loaded, personal injury or damage could result from improper handling or installation. Be careful when installing this component.

NOTE

Considerable force may be required when moving the Quick-Pitch™ **T-handle** forward or backward.

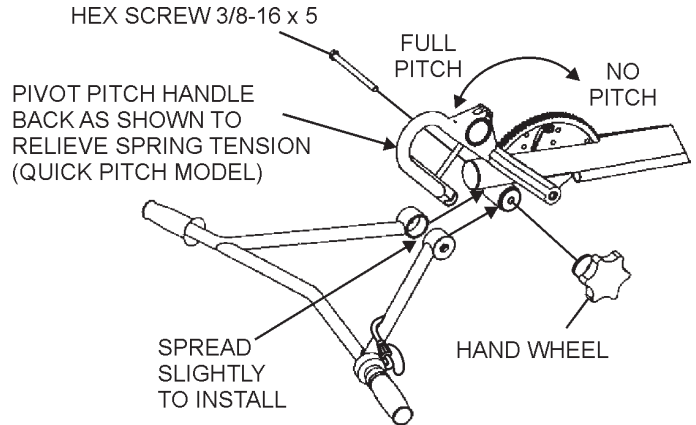
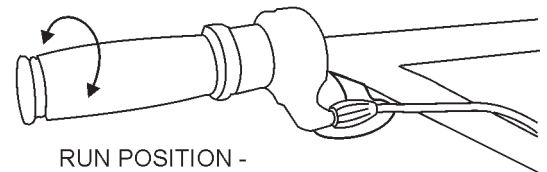

Figure 6. Handlebar Installation

Throttle Cable Installation (Honda and Robin Engines)

1. Set the **throttle** (Figure 7) to the idle position by rotating the grip toward the operator and away from the engine.

IDLE POSITION - DECREASE THROTTLE



RUN POSITION - INCREASE THROTTLE

Figure 7. Throttle

2. Feed the throttle cable through the cable housing. Make sure the throttle indicator is on 1".
3. Connect the throttle cable to the engine. (Figure 8), **Honda** and (Figure 9), **Robin**. There should be a piece of wire installed on the trowel to show where to route the throttle cable. When connecting the cable housing, make sure that no more than **1/4" (6.4mm)** of the cable housing protrudes past the housing clamp on the engine.

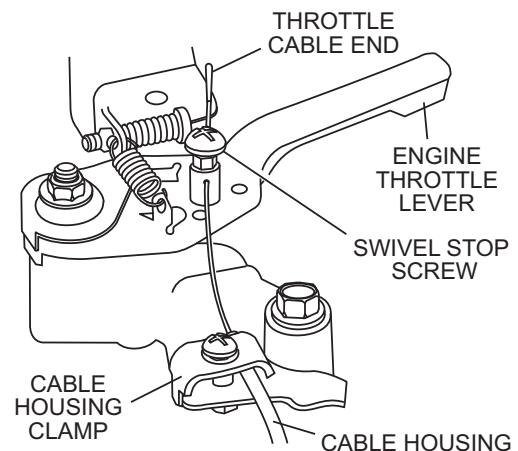

Figure 8. Throttle Cable Connection (HONDA)

BA-SERIES TROWEL — ASSEMBLY AND INSTALLATION

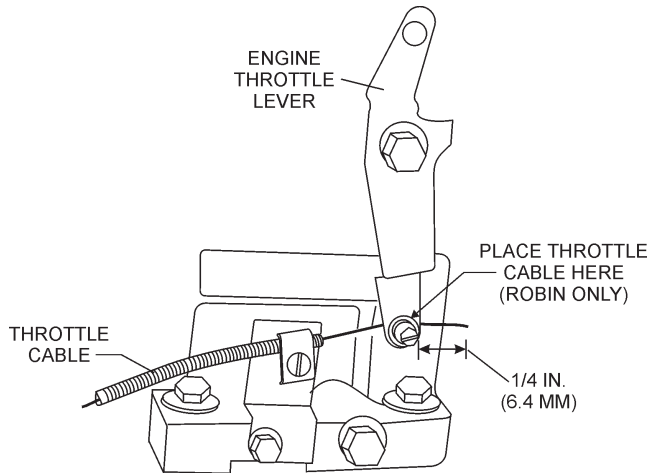

Figure 9. Throttle Cable Connection (ROBIN)

4. Tighten cable clamp screw and swivel stop screw.
5. After the cable has been installed on the engine, adjust and tighten operator position of the handle to lock the throttle cable at the proper length.
6. Adjust cable tension by rotating the barrel adjuster. (Figure 10)

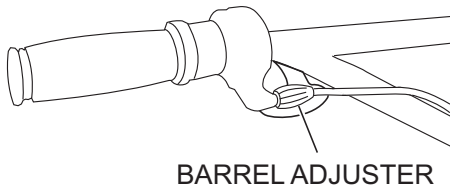

Figure 10. Barrel Adjuster

7. These are general instructions. Installation of the throttle cable may vary for different engine configurations. Please look for more detailed instructions inside the box containing the handle. These more detailed instructions should provide adequate guidance for installing.

Handle Height Adjustment

If handle height adjustment is desired, a handle wedge kit can be purchased for your trowel by ordering P/N 2576 from your Multiquip dealer. These wedges are placed between the handle and the gearbox to adjust the operating height of the handle. This kit comes complete with wedges, new bolts and installation instructions. This will move your operating handle position up or down approximately 3" (76mm).

Safety Kill Wire

Locate the **RED** wire protruding from the handle tube (Figure 11) and connect it to the **RED** tail wire on the engine. Test the kill switch to insure proper operation.

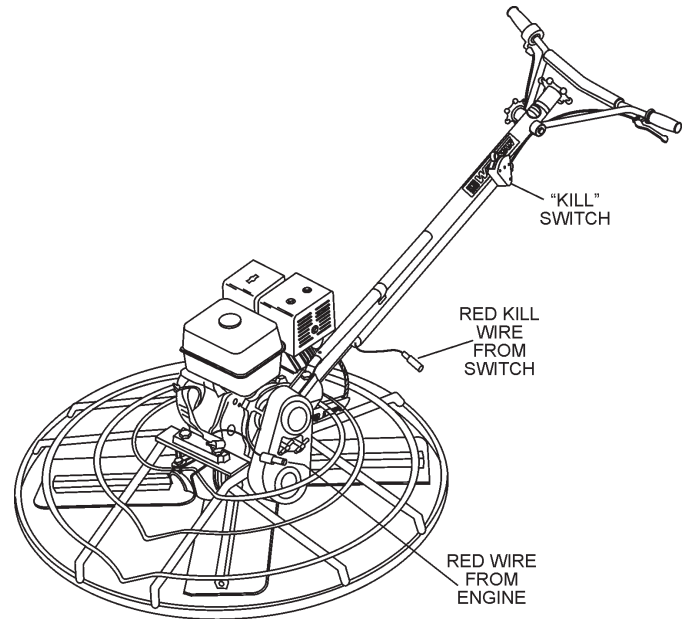

Figure 11. Engine Kill Wire Connection

Pitch Cable Installation

1. Expose the pitch cable to maximum by adjusting the handle pitch to the "no pitch" position. On the standard model turn the pitch control counter-clockwise, (Figure 12). On the Quick-Pitch™ model, pivot the pitch handle forward or no pitch, (Figure 13).

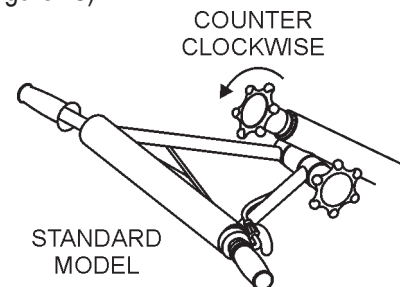

Figure 12. "No Pitch" Position (Standard)

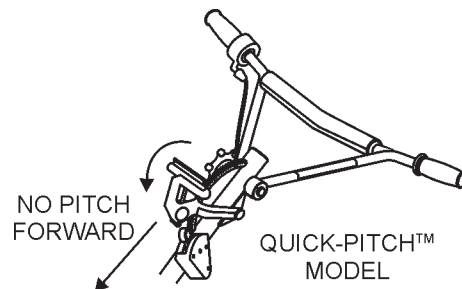

Figure 13. "No Pitch" Position (Quick-Pitch™)

BA-SERIES TROWEL — ASSEMBLY AND INSTALLATION

2. Lock the spring in the compressed position, by releasing the blade pitch adjustment trigger, (Quick-Pitch™ model).
3. Remove one brass set nut from the blade pitch cable end as shown in (Figure 14).
4. Thread the second brass set nut towards the cable as far as possible.

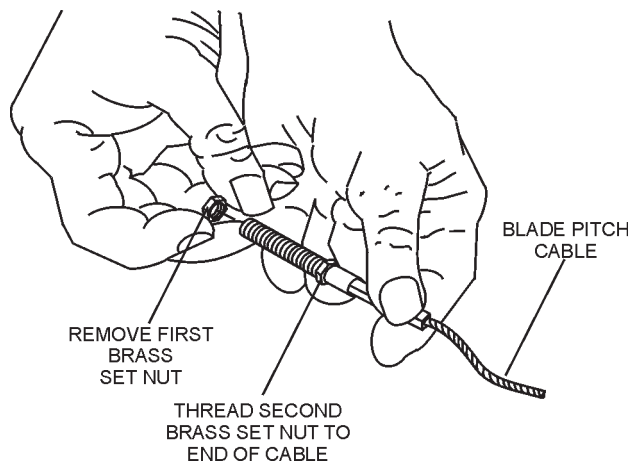

Figure 14. Blade Pitch Cable

5. Insert the cable end through the yoke eyelet (Figure 15) Tighten the first brass set nut by hand to remove all the slack from the cable.
6. Using a wrench, tighten the second brass set nut up against the yoke boss. This will lock the cable in place.
7. Use a wrench and finish tightening the first brass set nut up against the yoke boss.

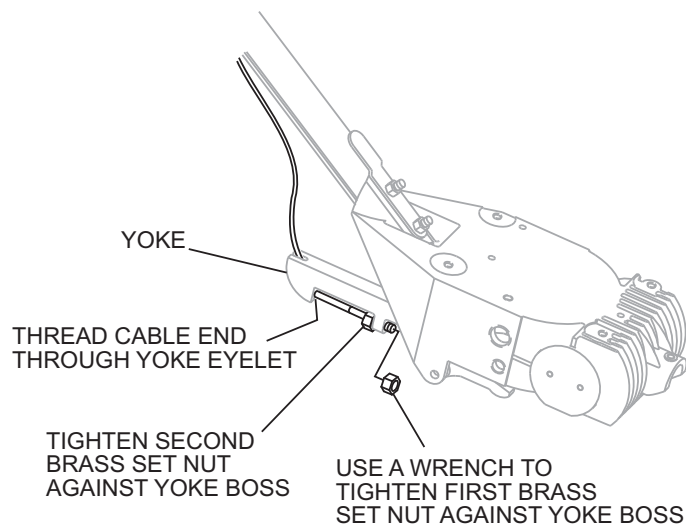

Figure 15. Cable Yoke Attachment

Pre-load Adjustment (Quick-Pitch™ Models Only)

1. After the Quick-Pitch™ handle has been installed on the trowel, spring pre-load adjustment will be required.
2. Locate the adjustment screw on the underside of the handle tube (Figure 16).

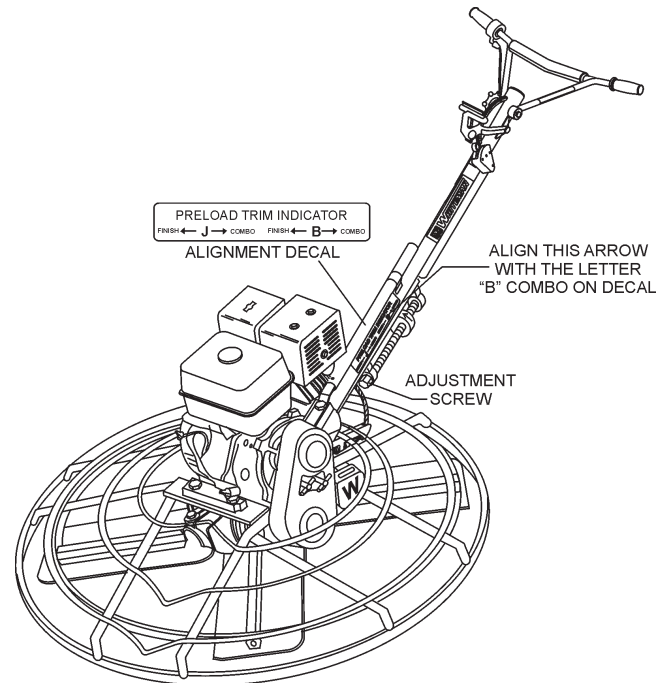

Figure 16. Pre-load Adjustment

3. A **decal** has been placed on the side of the handle tube to assist the user in the adjustment of the spring.
4. Align the **arrow** on the adjustment screw with the letter "**B**" **COMBO** on the **decal**. The letter "**B**" stands for BA-Series Walk-Behind trowel.
5. Test the pitch control operation and adjust if necessary.

BA-SERIES TROWEL— PRE-INSPECTION

CAUTION



NEVER operate the trowel in a confined area or enclosed area structure that does not provide ample *free flow of air*.



ALWAYS wear approved eye and hearing protection before operating the trowel.

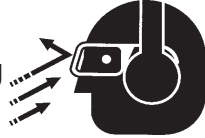

NEVER place hands or feet inside the guard rings while the engine is running. **ALWAYS** shut the engine down before performing any kind of maintenance service on the trowel.



It is recommended that the trowel's **kill switch** be used to stop the engine after every use. Doing this will verify that the switch is working properly and presents no danger to the operator.

Before Starting

1. Read safety instructions at the beginning of manual.
2. Clean the **trowel**, removing dirt and dust, particularly the engine cooling air inlet, carburetor and air cleaner.
3. Check the air filter for dirt and dust. If air filter is dirty, replace air filter with a new one as required.
4. Check carburetor for external dirt and dust. Clean with dry compressed air.
5. Check fastening nuts and bolts for tightness.

Engine Oil Check

1. To check the engine oil level, place the trowel on secure level ground with the engine stopped.
2. Remove the filler dipstick from the engine oil filler hole (Figure 17) and wipe it clean.

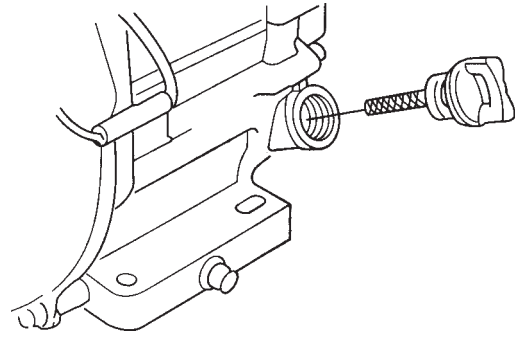

Figure 17. Engine Oil Dipstick (Removal)

3. Insert and remove the dipstick without screwing it into the filler neck. Check the oil level shown on the dipstick.
4. If the oil level is low (Figure 18), fill to the edge of the oil filler hole with the recommended oil type (Table 4). Maximum oil capacity is 400 cc.

NOTE

Reference manufacturer engine manual for specific servicing instructions.

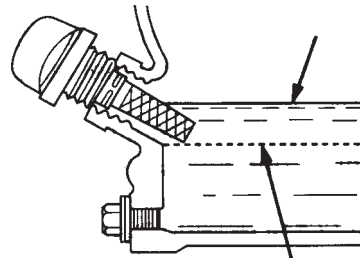

Figure 18. Engine Oil Dipstick (Oil Level)

Table 4. Oil Type

Season	Temperature	Oil Type
Summer	25°C or Higher	SAE 10W-30
Spring/Fall	25°C~10°C	SAE 10W-30/20
Winter	0°C or Lower	SAE 10W-10

BA-SERIES TROWEL— PRE-INSPECTION



Fuel Check

Motor fuels are highly flammable and can be dangerous if mishandled. **DO NOT** smoke while refueling. **DO NOT** attempt to refuel the trowel if the engine is **hot!** or **running**.

1. Remove the gasoline cap located on top of fuel tank.
2. Visually inspect to see if fuel level is low. If fuel is low, replenish with unleaded fuel.
3. When refueling, be sure to use a strainer for filtration. **DO NOT** top-off fuel. Wipe up any spilled fuel.

Gearbox Oil

1. Determine if the **gearbox** oil is low by removing the oil plug located on the side of the gearbox. This plug will be marked by the "**check**" decal. See Figure 19. The correct level of the lubrication oil should be to the bottom of the fill plug.

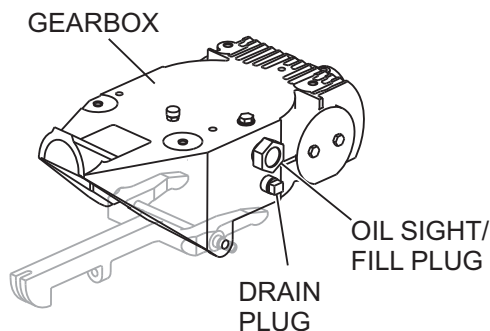

Figure 19. Gearbox

2. If oil does not reach the middle of the **sight glass** fill with type ISO 680 (Whiteman P/N 10139) gearbox lubricant oil until the oil level reaches the middle of the sight glass.

V-belt Check

A worn or damaged V-belt can adversely affect the performance of the trowel. If a V-belt is defective or worn simply replace the V-belt as outlined in the maintenance section of this manual.

Blade Check

Check for worn or damaged blades. Check to see if one blade is worn out while the others look new. If this is the case there could be a blade pitch problem. Refer to the maintenance section of this manual for blade pitch adjustment procedure. Replace any worn blades.

CONTROLS

Safety Kill Switches

This trowel has been equipped with a safety kill switch or a hand operated clutch. Safety kill switches or hand clutches should be tested every time the engine is started.

NOTE

NEVER! *disable or disconnect the kill switch. It is provided for operator safety. Injury may result if it is disable, disconnected or improperly maintained.*

Centrifugal Type Kill Switch

The switching mechanism of this switch (Figure 20) should operate freely and should **always** be kept in this condition. With the switch in the **OFF** position, the engine should not start or run. The purpose of this switch is to stop the engine in a runaway situation, (i.e. -the operator releasing the handle during operation).

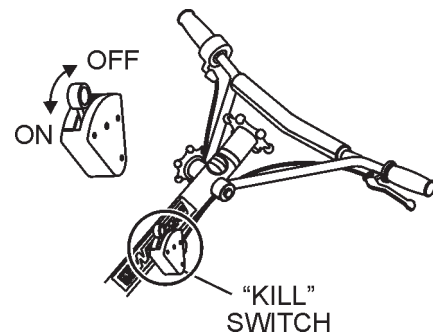

Figure 20. Centrifugal Kill Switch

Hand Clutch

Some finisher models are equipped with a **hand operated clutch**. These units are not equipped with a safety kill switch. The unit automatically stops rotating when the clutch lever is released.

DO NOT let the machine sit unused with the engine at high speed for an extended period of time. It will cause premature belt wear or may destroy the belt. Always set the engine speed to idle when the hand clutch is disengaged.

BA-SERIES TROWEL — INITIAL START-UP

CAUTION

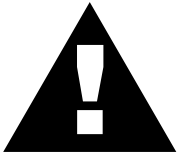

The trowel is **heavy** and **awkward** to move around. Use proper heavy lifting procedures and **DO NOT lift the trowel by the guard rings**.

Lifting the Trowel Onto a Slab.

Auxiliary Lifting Tube

Remove the auxiliary lifting tube located on top of the main handle. Insert the tube into the socket located on the opposite side of the gearbox (Figure 21) from the handle.

Make sure that the hole in the tube engages with the pin in the socket. With one person lifting from the main handle, and another lifting from the auxiliary lifting tube pick up the machine to move onto a slab.

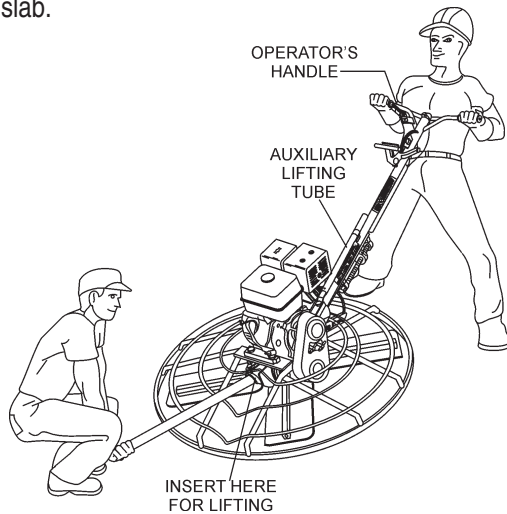

Figure 21. Lifting the Trowel

CAUTION



The trowel must be stabilized by the person carrying the **operator's handle** (Figure 21). If it is not stabilized properly the handle may swing around and **flip** the trowel, thus causing damage to the trowel and bodily injury.

Lifting Bale (Option)

The lift bale is optional on new trowels. It provides an optimal lift point for moving the trowel. **Lift bales** or **forklift** can be used to lift a trowel up onto a building with a crane. See "**Optional Equipment**" section in this manual for ordering information.

Using a **crane** to move a machine with a lift bale is highly recommended, and is perfectly safe for the machine. Extra care should be taken when lifting the machine off the ground, though. Serious damage to the machine or personal injury could be caused by dropping a trowel.

This section is intended to assist the operator with the initial start-up of the walk-behind trowel. It is extremely important that this section be read carefully before attempting to use the trowel in the field.

DO NOT use your trowel until this section is thoroughly understood.

CAUTION



DO NOT attempt to operate the trowel until the Safety, General Information and Inspection sections of this manual have been read and thoroughly understood. Depending on engine manufacturer, operating steps may vary. See engine manufacturer's operating manual. The following start-up procedure makes reference to a **HONDA 13 HP Engine (Manual Start)**.

Starting the Engine (HONDA engine)

1. Place the engine **fuel valve lever** (Figure 22) to the "ON" position.

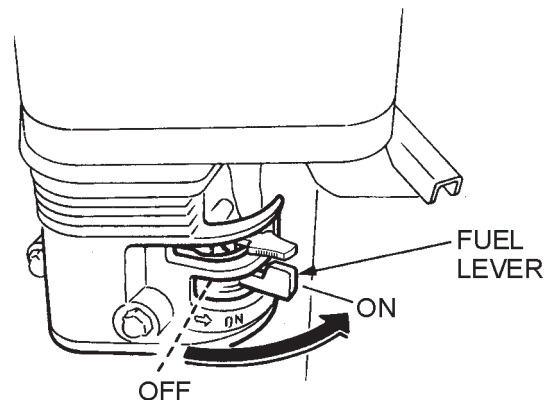

Figure 22. Engine Fuel Valve Lever

2. Rotate the **throttle** (Figure 23) to the "idle" position.

IDLE POSITION

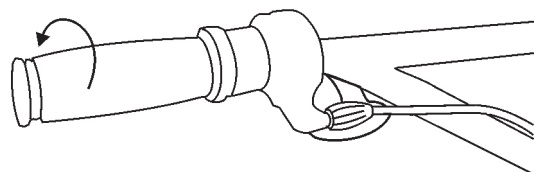

Figure 23. Throttle (Idle Position)

- Place the **centrifugal kill switch** (Figure 24) in the "ON" position. For models that use this feature.

CAUTION



NEVER disable or disconnect the centrifugal kill switch. It is provided for the operators' safety and injury may result if it is disabled, disconnected or improperly maintained.

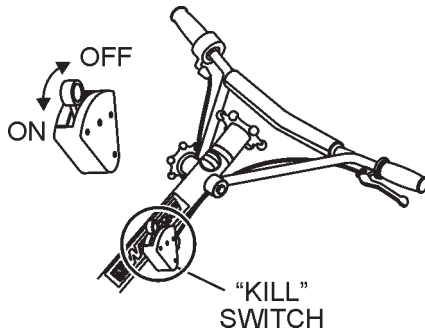

Figure 24. Centrifugal Kill Switch

- Place the **Choke Lever** (Figure 25) in the "OPEN" position

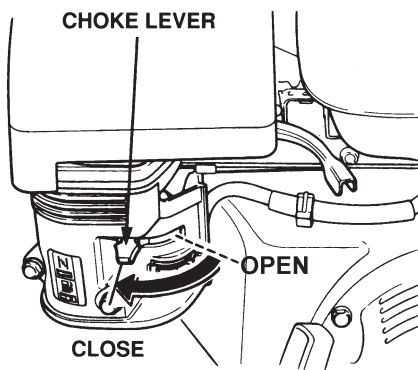

Figure 25. Engine Choke Lever

- Grasp the starter grip (Figure 26) and slowly pull it out. The resistance becomes the hardest at a certain position, corresponding to the compression point. Pull the starter grip briskly and smoothly for starting.

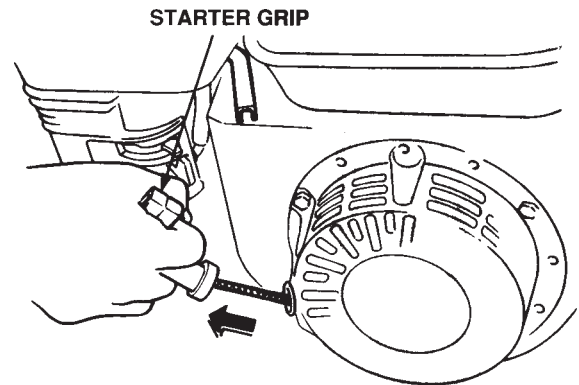

Figure 26. Starter Grip

- If the engine has started, slowly return the choke lever (Figure 25) to the **CLOSED** position. If the engine has not started repeat steps 1 through 5.
- Before the trowel is placed into operation, run the engine for several minutes. Check for fuel leaks, and noises that would associate with a loose guard ring and/or covers.
- To begin troweling, rotate the throttle (Figure 27) toward the "RUN" position.

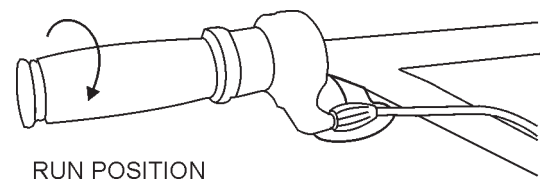

Figure 27. Throttle (Run Position)

BA-SERIES TROWEL — OPERATION

The following steps are intended as a basic guide to machine operation, and are not to be considered a complete guide to concrete finishing. We suggest that all operators (experienced and novice) read "*Slabs on Grade*" published by the **American Concrete Institute, Detroit, Michigan**. Read the "Training" section of this manual for more information.

Pitching The Blades

Quick Pitch Handle

1. To pitch the blades upwards using the "**Quick-Pitch™**" **T-handle**, (Figure 28) simply squeeze the trigger lock and pull the **T-handle** towards the operator. Pushing the **T-handle** towards the engine will cause the blades to lay flat.

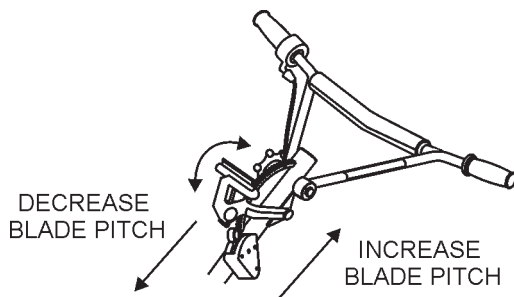

Figure 28. Quick-Pitch™ T-Handle

Standard Handle

1. To pitch the blades upwards using the "**Standard**" handle, (Figure 29) simply turn the **star-wheel** clockwise. Turning the star wheel counter clockwise will cause the blades to lay flat.

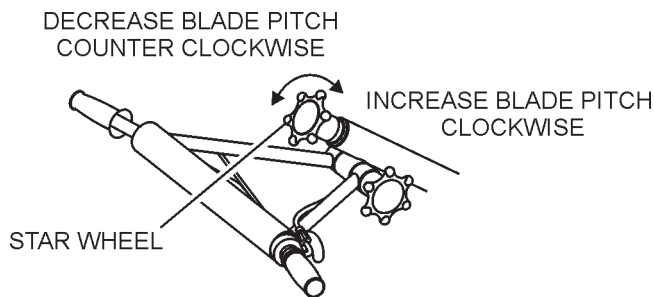

Figure 29. Standard Handle

Maneuvering the Trowel

1. Get into the operator's position behind the handle. With a secure foothold and a firm grasp on the handles slowly increase the engine speed until the desired blade speed is obtained.

If your trowel has a **hand clutch** (Figure 30), set your engine speed with the throttle, then pull on the hand clutch lever to start the blades turning. Adjust the blade speed after the hand clutch is fully engaged.

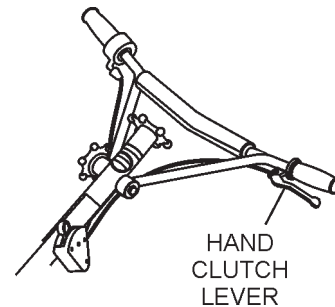

Figure 30. Hand Clutch Lever

2. To maneuver the trowel, gently lift up on or press down on the main trowel handle. To move the machine to the operator's left, **lift up** on the handle, to move machine to the right, **push down** on the handle.
3. The best method for finishing concrete is to slowly walk backwards (Figure 31) with the trowel, guiding the trowel from side to side. This will cover all footprints on wet concrete.
4. Remember that if you let go of the trowel, just step away and let the trowel come to a complete stop before trying to recover the trowel.

BA-SERIES TROWEL — OPERATION

Figure 32 below illustrates a typical walk-behind trowel application. Practice maneuvering the trowel. The trick is to let the trowel do the work.

Continue to practice maneuvering the trowel. Try to practice as if you were finishing a slab of concrete. Practice edging and covering a large area. Remember a good finishing technique is to work backwards. Be careful when moving backwards so that hazards can be avoided. The best way to get accustomed to the trowel is repeated use.

To move the trowel to the operator's left, **lift up** on the handle, to move the trowel to the right **push down** on the handle.

Remember! that if you let go of the trowel, just **step away** and let the trowel come to a complete **STOP** before trying to recover the trowel.

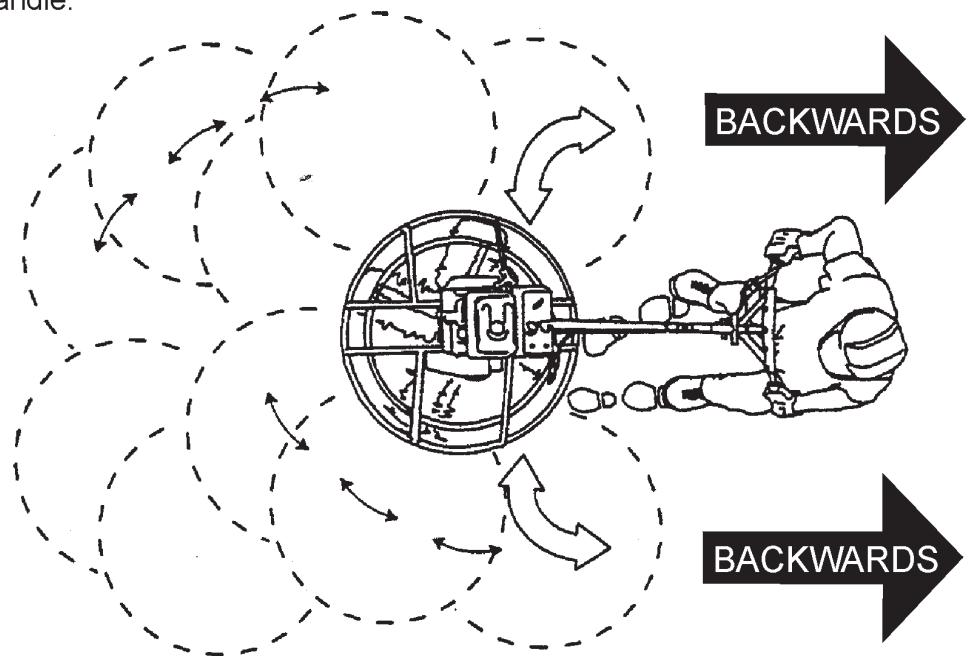

The best method for finishing concrete is to slowly walk **backwards** with the trowel, guiding the trowel from side to side. This will cover all footprints on wet concrete.

Figure 31. Maneuvering The Trowel

CAUTION



NEVER place your **feet** or **hands** inside the guard rings while starting or operating this equipment.

CAUTION



ALWAYS keep clear of **rotating** or **moving** parts while operating this equipment.

BA-SERIES TROWEL — OPTIONS

Blades

NOTE

Blades should be changed when they fail to finish concrete in a satisfactory manner.

Blades are a vital part of finishing concrete. This trowel, or **finisher**, has been designed to finish concrete and the blades are built to stringent quality standards out of the finest trowel steel. If you need replacement blades, consult your parts list in this manual for part numbers and order them from your Multiquip parts dealer or importer.

Combo Blades

This trowel was equipped with combination **float/finish** (Figure 32) blades as original equipment. These blades have been designed for optimum performance in both the floating and finishing operations. These blades are versatile and should take care of most troweling needs.

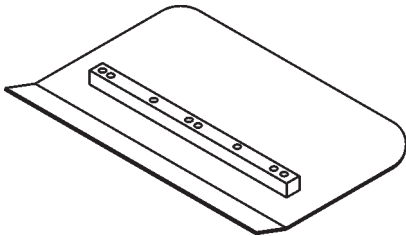

Figure 32. Combination Blade

Finish Blades (Optional)

These blades (Figure 33) have been specifically designed for finish operations with this trowel. They will provide a premium surface finishing capability from your trowel. They should only be used after the concrete has set to the point where the trowel does not sink into the concrete when placed on it.

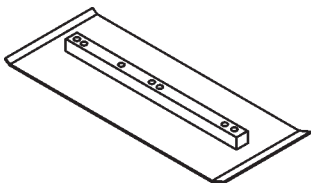

Figure 33. Finish Blade

Clip-On Float Blades (Optional)

These blades will clip (Figure 34) on to an existing installed blade, allowing your finisher to float on “wet” concrete so that the troweling operation can begin as early as possible. They are easily removable, so that after the floating operation, when the concrete is sufficiently cured, they can be removed to expose the finish blades for continued troweling.

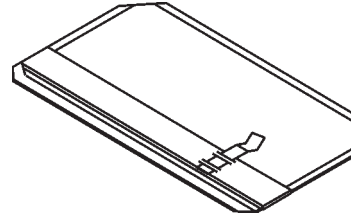

Figure 34. Clip-On Float Blade

Float Discs (Optional)

These round discs (Figure 35) attach to the spiders and allow the machine to “float” on “wet” concrete. The disc design allows early floating and easy movement from wet to dry areas. They are also very effective in embedding large aggregates and surface hardeners.

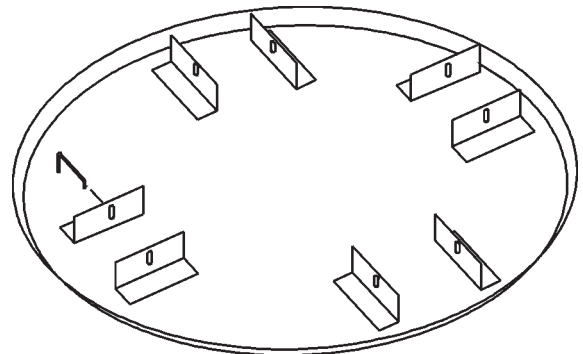

Figure 35. Float Disk

Grinding Attachments

Available grinding attachments are used for grinding surface imperfections or joints. These attachments allow greater utilization of your trowel. Figure 36 illustrates a typical grinding disk assembly, complete with hub and stone mounting plate.

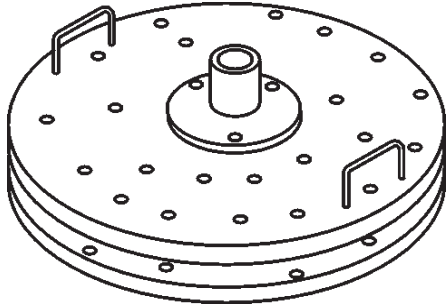

Figure 36. Grinding Disk

Trowel Arm Adjustment Tool

If blades show uneven wear patterns or some tend to wear out faster than others, the trowel arms may need to be adjusted. Whiteman makes a special tool (Figure 38) that will adjust all of the trowel arms consistently. The Trowel Arm Fixture P/N is 1817.

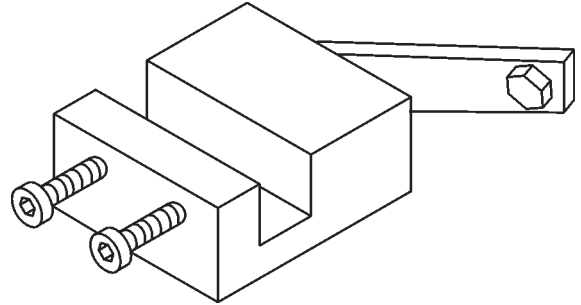

Figure 38. Trowel Arm Adjustment Fixture

Lifting Bale

There is a heavy duty, center balance type lifting bale (Figure 37) made specifically for your trowel. These bales are ideal for lifting and transporting your trowel. They are designed to lift the finisher and balance it on its center of gravity, providing great stability while lifting. This option is not available on electric trowel models.

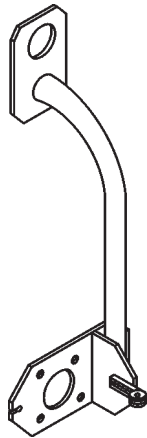

Figure 37. Lifting Bale

BA-SERIES TROWEL — MAINTENANCE

NOTE

See the engine manual supplied with your machine for appropriate engine maintenance schedule and troubleshooting guide for problems.

At the front of the book (Page 7) there is a "**Daily Pre-Operation Checklist**". Make copies of this checklist and use it on a daily basis.

CAUTION!



ALWAYS allow the engine to cool before servicing. **NEVER** attempt any maintenance work on a **hot!** engine.



MAINTENANCE SCHEDULE

Daily (8-10 Hours)

1. Check the oil level in the engine crankcase and gear box, fill as necessary.

2. Check V-belt.

Weekly (50-60 Hours)

1. Relube arms, thrust collar and clutch.

2. Replace blades if necessary.

3. Check and clean or replace the engine air filter as necessary.

4. Replace engine oil and filter as necessary, see engine manual.

Monthly (200-300 Hours)

1. Remove, clean, reinstall and relube the arms and thrust collar. Adjust the blade arms.

2. Remove, clean, reinstall clutch.

Yearly (2000-2500 Hours)

1. Check and replace if necessary the arm bushings, thrust collar bushings and shaft seals.

2. Check pitch control cables for wear.

3. Adjust blade speed.

Trowel Arm Adjustment Procedure

NOTE

The following procedure should be followed to adjust trowel arms when it becomes apparent that the trowel is finishing poorly or in need of routine maintenance.

A **level**, clean area to test the trowel prior to and after is essential. Any unlevel **spots** in the floor or debris under the trowel blades will give an incorrect perception of adjustment. Ideally, a 5 x 5" three-quarter inch thick **flat** steel plate should be used for testing.

1. To determine which blades need adjustment, place the trowel in the test area (three-quarter inch thick plate) and look for the following conditions:

■ Pitch the blades as flat as possible and look at the **adjustment bolts**. They should all barely make contact with the **lower wear plate** on the spider. If you can see that one of them is not making contact, some adjustment will be necessary.

■ Is the machine wearing out blades unevenly (i.e. one blade is completely worn out while the others look new)?

Figure 39 below illustrates a "**worn spider bushings or bent trowel arms**". Check to see that adjustment bolt is barely touching (0.10" max. clearance) lower wear plate. All alignment bolts should be spaced the same distance from the lower wear plate.

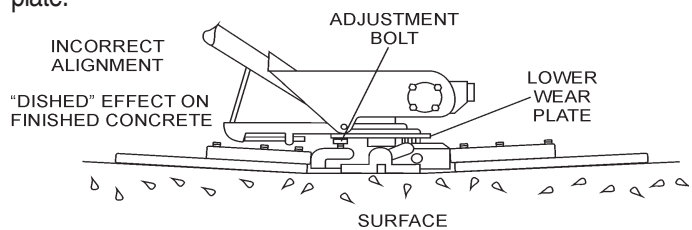

Figure 39. Worn Spider Plate

Figure 40 below illustrates the "**correct alignment**" for a spider plate (as shipped from the factory).

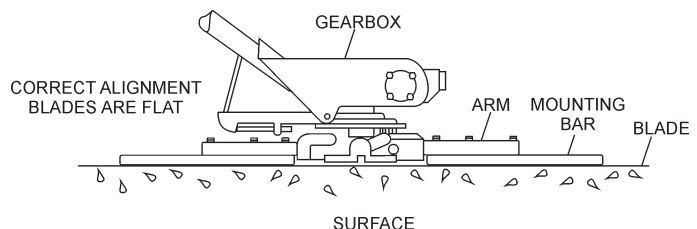

Figure 40. Correct Spider Plate Alignment

BA-SERIES TROWEL — MAINTENANCE

2. Start engine, and bring trowel blades up to full speed and look for the following conditions:
 - Does the trowel have a perceived rolling or bouncing motion when in use?
 - Look at the trowel while it is running, does the guard ring “rock up and down” relative to the ground?

Spider Removal

1. Once it is determined that an adjustment is required, remove the spider assembly from the gearbox shaft as follows:
 - a. Locate the cone point square head set screw (Figure 41) and attached jam nut found on the side of the spider assembly.

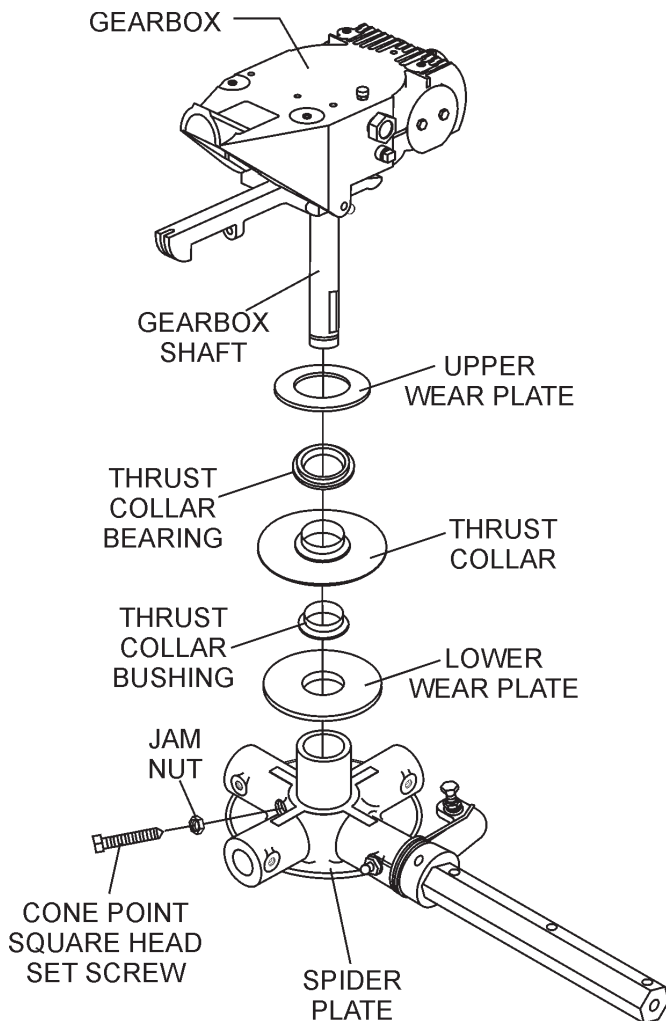

Figure 41. Spider/Gearbox Removal

- b. Loosen the jam nut and cone point square head set screw, and carefully lift the **upper trowel assembly** off of the spider assembly. A slight tap with a rubber mallet may be necessary to dislodge the spider from the main shaft of the gearbox.
 - c. If the trowel is equipped with an outer stabilizer ring (Figure 42), remove the four bolts at the end of each spider arm.

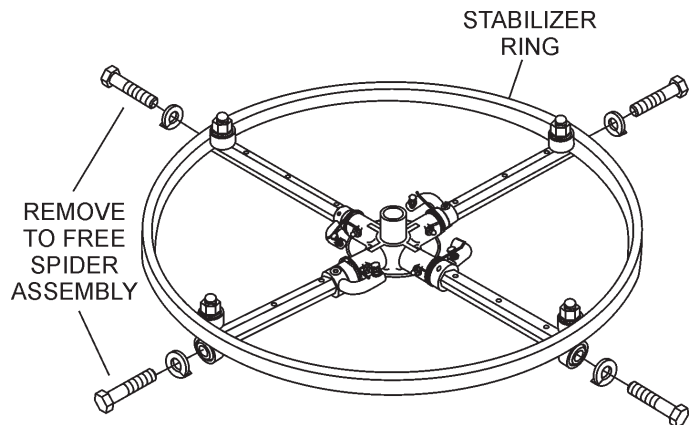

Figure 42. Stabilizer Ring

- d. Examine stabilizer ring for out of round or bends. If ring is damaged, replace ring. If ring is found to be correct with no damage, set aside.

Trowel Arm Removal

1. Each trowel arm is held in place at the spider plate by a hex head bolt (zerk grease fitting) and a roll pin. Remove both the hex head bolt and the roll pin (Figure 43) from the spider plate.
2. Remove the trowel arm from the spider plate.

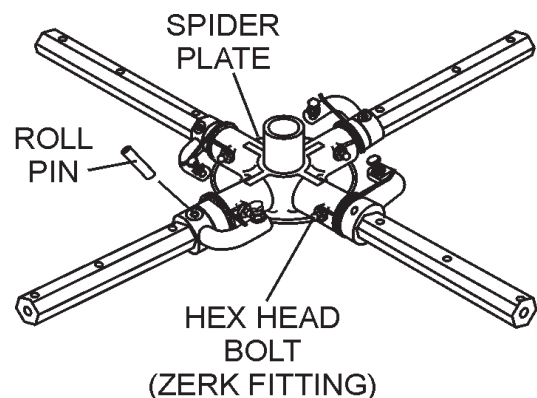

Figure 43. Removing Roll Pin and Zerk Grease Fitting

BA-SERIES TROWEL — MAINTENANCE

3. Should the trowel arm inserts (bronze bushing) come out with the trowel arm, remove the bushing from the trowel arm and set aside in a safe place. If the bushing is retained inside the spider plate, carefully remove the bushing.
4. Examine the bronze trowel arm bushing insert (Figure 44), clean if necessary. Replace bushing if out of round or worn.

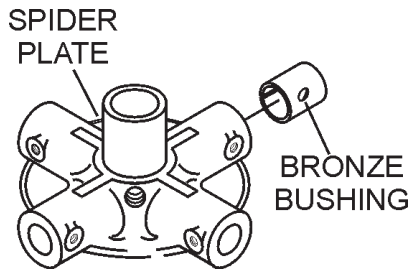

Figure 44. Bronze Bushings

Trowel Blade Removal

1. Remove the trowel blades from the trowel arm by removing the three hex head bolts (Figure 45) from the trowel arm. Set blades aside.

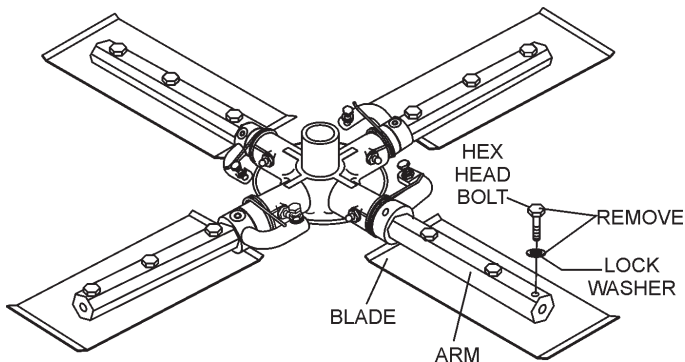

Figure 45. Trowel Blades

2. **Wire brush** any build-up of concrete from all six sides of the trowel arm. Repeat this for the remaining three arms.

Trowel Arm Flatness Test

1. Using a piece of 3/4 inch thick steel plate or any surface which is **true** and **flat**, check all **six sides** of each trowel arm for flatness.
2. Check each of the six sides of the trowel arm (hex section only) using a ten thousandths of an inch (max.) feeler gauge (Figure 46) between the flat of the trowel arm and an **extremely flat** test surface.

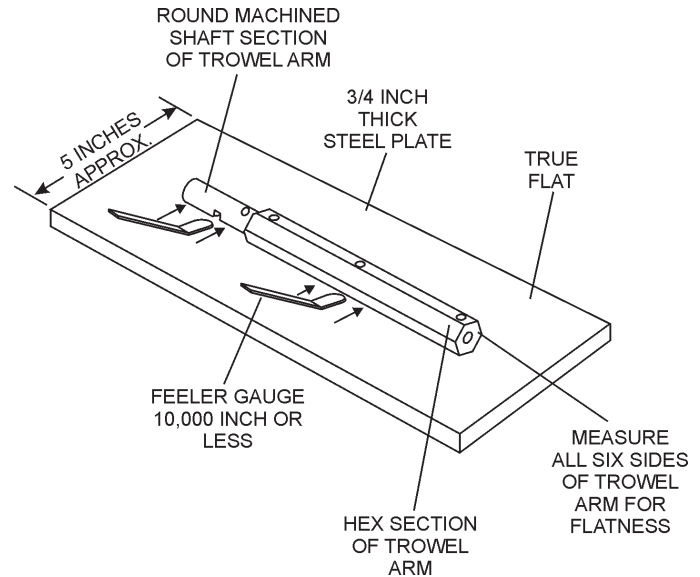

Figure 46. Trowel Arm Flatness Test

3. If the trowel arm is found to be **uneven** or **bent**, replace the trowel arm. A bent trowel will not allow the trowel to operate in a smooth fluid rotation.
4. Next, check each of the six sides of the round machined shaft section of the trowel arm. Each section should have the **same clearance** between the round of the trowel arm shaft and the test surface.

NOTE

Trowel arms can be damaged by rough handling or by striking exposed plumbing or forms while in operation. **ALWAYS** look-out for objects which might cause damage to the trowel arms.

Trowel Arm Adjustment

Shown in Figure 47 is the adjustment fixture with a trowel arm inserted. As each trowel arm is locked into the fixture, the arm bolt is adjusted to where it contacts a stop on the fixture. This will consistently adjust all of the trowel arms, keeping the finisher as flat and evenly pitched as possible.

1. Locate the trowel arm adjustment tool P/N 1817. Set the adjustment tool for a clock-wise blade rotation, meaning the fixture arm is in the "UP" position.

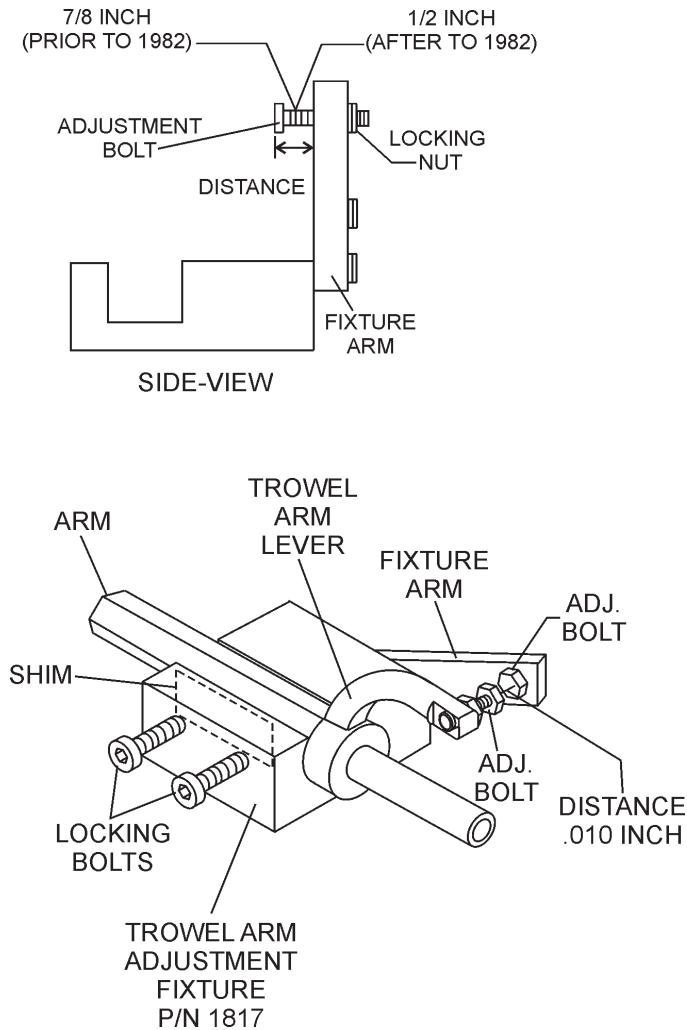

Figure 47. Trowel Arm Adjustment Tool

2. Trowels manufactured prior to June of 1982 require that the distance from the end of the adjusting bolt and the fixture arm must be 7/8" (Figure 48). Conversely, trowels manufactured after June of 1982 require that the distance from the end of the adjusting bolt and the fixture arm must be 1/2".

3. Un-screw the locking bolts on the adjustment tool, and place the trowel arm into the adjustment fixture channel as shown in Figure 48. A *thin shim* may be required to cover the blade holes on the trowel arm. Make sure to align the trowel adjustment bolt with the fixture adjustment bolt.
4. Using an allen wrench, tighten the locking bolts on the adjustment tool and securely lock the trowel arm in place.
5. Loosen the locking nut on the trowel arm lever, then turn the trowel arm adjusting bolt until it barely touches (.010") the adjusting bolt on the fixture.
6. After the correct adjustment has been made, tighten lock nut on trowel arm lever to lock in place.
7. Loosen locking bolts on adjustment fixture, and remove trowel arm from fixture.
8. Repeat steps 2-7 for the remaining trowel arms.

Re-Assembly

1. Clean and examine the upper/lower wear plates and thrust collar. Examine the entire spider assembly. Wire brush any concrete or rust build-up. If any of the spider components are found to be damaged or out of round, replace them.
2. Make sure that the bronze trowel arm bushing is not damage or out of round. Clean the bushing if necessary. If the bronze bushing is damage or worn, replace it.
3. Reinstall bronze bushing onto trowel arm.
4. Repeat steps 2-3 for each trowel arm.
5. Make sure that the spring tensioner is in the correct position to exert tension on the trowel arm.
6. Insert all trowel arms with levers into spider plate (with bronze bushing already installed) using care to align grease hole on bronze bushing with grease hole fitting on spider plate.
7. Lock trowel arms in place by tightening the hex head zerk grease fitting and jam nut.
8. Re-install the blades back onto the trowel arms.
9. Install stabilizer ring onto spider assembly.
10. Reinstall **lower wear plate**, **thrust collar** and **upper wear ring** in the **reverse order** that they were dis-assembled onto the spider shaft. Make sure that there is little or no lateral movement between the thrust collar and the spider shaft.

BA-SERIES TROWEL — MAINTENANCE

11. Carefully lift the **upper trowel assembly**, line up the key-way on gear box main shaft and insert into spider assembly.
12. Reinstall square head cone point into spider plate and tighten in place. Tighten jam nut. Use care in making sure point of set screw engages groove in gear box main shaft.
13. Lubricate all grease points (zerk fittings) with premium "**Lithum 12**" based grease, conforming to NLG1 Grade #2 consistency.

Testing

1. Place trowel in test area, start engine and test trowel for smoothness.
2. If trowel bounces has excessive vibration or does not run smoothly repeat alignment procedure.

Changing a Blade

Whiteman recommends that **all the blades be changed at the same time**. The machine may wobble or bounce if only some of the blades are changed at one time.

1. Place the machine on a flat, level surface. Adjust the blade pitch control to make the blades as flat as possible. Note the blade orientation on the trowel arm.

NOTE

Before removing the blades, please note the orientation of the blade on the trowel arm.

1. Remove the three bolts and lock washers that secure the blade to the trowel arm. Remove the blade.
2. Using a wire brush, scrape all concrete particles and foreign debris from the trowel arm.
3. Install the new trowel blade onto the trowel arm. Make sure blade is installed correctly, maintaining the proper orientation for direction of rotation.
4. Reinstall the three bolts and lock washers that secure the blade to the trowel arm. Tighten all three bolts securely.
5. Repeat steps 1-4 for all remaining blades.

Hand Clutch Adjustment

Some trowels are equipped with a hand-operated clutch instead of an automatic centrifugal clutch. Two types of hand clutches have been installed. Both are belt-tightener type clutches. They operate by removing **slack** in the V-belt which then transmits power from the engine to the gearbox.

There are two reasons to adjust the hand clutch: 1) operator comfort; 2) initial belt stretch and break-in.

The easiest and most simple adjustment is to adjust the clutch cable housing using the adjustment nut (Figure 48) located on the clutch lever. Rotating the nut provides either more or less (depending upon the direction of rotation) clutch engagement.

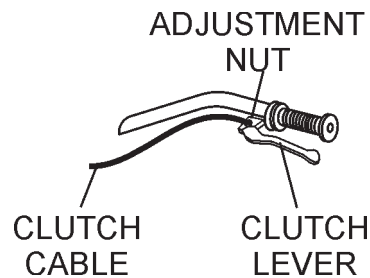

Figure 48. Hand Clutch Adjustment

Hand Clutch Disengagement

1. Start the trowel as outlined in the "**Initial Start-up**" section in this manual. Move the throttle lever so that the engine is running about 1/4 to 1/3 of full speed.
2. Grip the trowel handle firmly and carefully engage the clutch by squeezing the clutch lever toward the handle with your left hand. After the trowel is stabilized and you feel comfortable with its operation, use your right hand to adjust the housing adjustment nut.
3. Rotating the nut so that it backs out of the lever housing increases the engagement and also the squeezing force required to keep it engaged.

Too much squeezing force may cause premature hand fatigue. Too little squeezing force may cause belt slippage and premature belt wear. Each operator should experiment with the adjustment to get the optimum combination of squeeze force and belt grip.

4. After initial break-in (approximately 8 hours) the above procedure should be repeated to attain optimum operator comfort and belt wear.
5. After considerable belt wear, the adjustments mentioned above may have a little or no effect on clutch engagement. If this is the case, the belt should be replaced.

BA-SERIES TROWEL — TROUBLESHOOTING (TROWEL)

TABLE 6. TROUBLESHOOTING

SYMPTOM	POSSIBLE PROBLEM	SOLUTION
Engine running rough or not at all.	Kill switch malfunction?	Make sure that the kill switch is ON or replace switch if necessary.
	Fuel?	Look at the fuel system. Make sure there is fuel being supplied to the engine. Check to ensure that the fuel filter is not clogged.
	Ignition?	Check to ensure that the ignition switch has power and is functioning correctly.
Safety kill switch not functioning.	Other problems?	Consult engine manufacturer's manual.
	Loose wire connections?	Check wiring. Replace as necessary.
	Bad contacts?	Replace switch.
If trowel "bounces, rolls concrete, or makes uneven swirls in concrete".	Blades?	Make certain blades are in good condition, not excessively worn. Finish blades should measure no less than 2" (50mm) from the blade bar to the trailing edge, combo blades should measure no less than 3.5" (89mm). Trailing edge of blade should be straight and parallel to the blade bar.
	Spider?	Check that all blades are set at the same pitch angle as measured at the spider. A field adjustment tool is available for height adjustment of the trowel arms (see Optional Equipment).
	Bent trowel arms?	Check the spider assembly for bent trowel arms. If one of the arms is even slightly bent, replace it immediately.
	Trowel arm bushings?	Check the trowel arm bushings for tightness. This can be done by moving the trowel arms up and down. If there is more than 1/8" (3.2 mm) of travel at the tip of the arm, the bushings should be replaced. All bushings should be replaced at the same time.
	Thrust collar?	Check the flatness of the thrust collar by rotating it on the spider. If it varies by more than 0.02" (0.5 mm) replace the thrust collar.
	Thrust collar bushing?	Check the thrust collar by rocking it on the spider. If it can tilt more than 3/32" (2.4 mm) [as measured at the thrust collar O.D.], replace the bushing in the thrust collar.
	Thrust bearing worn?	Check the thrust bearing to see that it is spinning free. Note: Thrust cap, replace if necessary.
Machine has a perceptible rolling motion while running.	Main shaft?	The main output shaft of the gearbox assembly should be checked for straightness. The main shaft must run straight and cannot be more than 0.003" (0.08 mm) out of round at the spider attachment point.
	Yoke?	Check to make sure that both fingers of the yoke press evenly on the wear cap. Replace yoke as necessary.
	Blade Pitch?	Check to ensure that each blade is adjusted to have the same pitch as all other blades. Adjust per maintenance section in manual.

BA-SERIES TROWEL — TROUBLESHOOTING (TROWEL)

TABLE 6. TROUBLESHOOTING (CONTINUED)

SYMPTOM	POSSIBLE PROBLEM	SOLUTION
Clutch slipping or sluggish response to engine speed change.	Worn V-belts?	Replace V-belt.
	Dirty centrifugal clutch?	Disassemble and clean clutch.
	Defective or worn out centrifugal clutch?	Replace entire clutch.
	Hand clutch out of adjustment?	Adjust per instructions in maintenance section of this manual.
	Worn or defective hand clutch parts?	Replace parts as necessary.
	Worn bearings in gearbox?	Rotate input shaft by hand. If shaft rotates with difficulty, check the input and output shaft bearings. Replace as necessary.
	Worn or broken gears in gearbox?	Verify that the gearbox shaft rotates when the input shaft is rotated. Replace both the worm and worm gear as a set.

BA-SERIES TROWEL — TROUBLESHOOTING (ENGINE)

TABLE 7. TROUBLESHOOTING (ENGINE)

SYMPTOM	POSSIBLE CAUSE	SOLUTION
Difficult to start, "fuel is available, but no SPARK at spark plug".	Spark plug bridging?	Check gap, insulation or replace spark plug.
	Carbon deposit on spark plug?	Clean or replace spark plug.
	Short circuit due to deficient spark plug insulation?	Check spark plug insulation, replace if worn.
	Improper spark plug gap?	Set to proper gap.
Difficult to start, "fuel is available, and SPARK is present at the spark plug".	ON/OFF switch is shorted?	Check switch wiring, replace switch.
	Ignition coil defective?	Replace ignition coil.
	Improper spark gap, points dirty?	Set correct spark gap and clean points.
	Condenser insulation worn or short circuiting?	Replace condenser.
	Spark plug wire broken or short circuiting?	Replace defective spark plug wiring.
Difficult to start, "fuel is available, spark is present and compression is normal"	Wrong fuel type?	Flush fuel system, and replace with correct type of fuel.
	Water or dust in fuel system?	Flush fuel system.
	Air cleaner dirty?	Clean or replace air cleaner.
	Choke Open?	Close Choke.
Difficult to start, "fuel is available, spark is present and compression is low"	Suction/exhaust valve stuck or protruded?	Re-seat valves.
	Piston ring and/or cylinder worn?	Replace piston rings and or piston.
	Cylinder head and/or spark plug not tightened properly?	Torque cylinder head bolts and spark plug.
	Head gasket and/or spark plug gasket damaged?	Replace head and spark plug gaskets.
No fuel present inside priming bulb.	Fuel not available in fuel tank?	Fill with correct type of fuel.
	Fuel filter clogged?	Replace fuel filter.
	Fuel tank cap breather hole clogged?	Clean or replace fuel tank cap.
	Air in fuel line?	Bleed fuel line.

BA-SERIES TROWEL — EXPLANATION OF CODES IN REMARKS COLUMN

The following section explains the different symbols and remarks used in the Parts section of this manual. Use the help numbers found on the back page of the manual if there are any questions.

NOTICE

The contents and part numbers listed in the parts section are subject to change **without notice**. Multiquip does not guarantee the availability of the parts listed.

SAMPLE PARTS LIST

NO.	PART NO.	PART NAME	QTY.	REMARKS
1	12345	BOLT.....	1	INCLUDES ITEMS W/%
2%		WASHER, 1/4 IN.....		NOT SOLD SEPARATELY
2%	12347	WASHER, 3/8 IN....	1	MQ-45T ONLY
3	12348	HOSE		A/R ...MAKE LOCALLY
4	12349	BEARING	1	S/N 2345B AND ABOVE

NO. Column

Unique Symbols — All items with same unique symbol

(@, #, +, %, or >) in the number column belong to the same assembly or kit, which is indicated by a note in the “Remarks” column.

Duplicate Item Numbers — Duplicate numbers indicate multiple part numbers, which are in effect for the same general item, such as different size saw blade guards in use or a part that has been updated on newer versions of the same machine.

NOTICE

When ordering a part that has more than one item number listed, check the remarks column for help in determining the proper part to order.

PART NO. Column

Numbers Used — Part numbers can be indicated by a number, a blank entry, or TBD.

TBD (To Be Determined) is generally used to show a part that has not been assigned a formal part number at the time of publication.

A blank entry generally indicates that the item is not sold separately or is not sold by Multiquip. Other entries will be clarified in the “Remarks” Column.

QTY. Column

Numbers Used — Item quantity can be indicated by a number, a blank entry, or A/R.

A/R (As Required) is generally used for hoses or other parts that are sold in bulk and cut to length.

A blank entry generally indicates that the item is not sold separately. Other entries will be clarified in the “Remarks” Column.

REMARKS Column

Some of the most common notes found in the “Remarks” Column are listed below. Other additional notes needed to describe the item can also be shown.

Assembly/Kit — All items on the parts list with the same unique symbol will be included when this item is purchased.

Indicated by:
 “INCLUDES ITEMS W/(unique symbol)”

Serial Number Break — Used to list an effective serial number range where a particular part is used.

Indicated by:
 “S/N XXXXX AND BELOW”
 “S/N XXXX AND ABOVE”
 “S/N XXXX TO S/N XXX”

Specific Model Number Use — Indicates that the part is used only with the specific model number or model number variant listed. It can also be used to show a part is NOT used on a specific model or model number variant.

Indicated by:
 “XXXXX ONLY”
 “NOT USED ON XXXX”

“Make/Obtain Locally” — Indicates that the part can be purchased at any hardware shop or made out of available items. Examples include battery cables, shims, and certain washers and nuts.

“Not Sold Separately” — Indicates that an item cannot be purchased as a separate item and is either part of an assembly/kit that can be purchased, or is not available for sale through Multiquip.

BA-SERIES TROWEL — SUGGESTED SPARE PARTS

BA-SERIES TROWEL 1 TO 3 UNITS WITH HONDA GX240K1QA2ENGINE.

1 to 3 Units

Qty	P/N	Description
2	20856	SAFETY SWITCH
1	20285	CABLE STANDARD HANDLE
1	20297	CABLE QUICK-PITCH™
1	20435	THROTTLE LEVER W/CABLE
4	1157 A	BUSHING
4	1162 A	LUBE CAP
4	1167 A	SCREW
4	1456	NUT
4	1875	WASHER
4	1322	SCREW
1	21046	GASKET KIT
1	21047	BEARING KIT
4	1247	RUBBER GROMMET
4	1245	SPACER
1	2827	ARM (16-1/2")
2	0261	BELT (A-31) HONDA
2	0262	BELT (A-33) HONDA W/HANDCLUTCH
1	10968	THRUST COLLAR KIT
2	9807955846	SPARK PLUG HONDA
2	17620ZH7023	TANK CAP (HONDA)
2	17210ZE2505	AIR CLEANER ELEMENT (HONDA)
2	17218ZE2505	FILTER OUTER (HONDA)

BA-SERIES TROWEL 1 TO 3 UNITS WITH ROBIN EH25-2 ENGINE.

1 to 3 Units

Qty	P/N	Description
2	20856	SAFETY SWITCH
1	20285	CABLE STANDARD HANDLE
1	20297	CABLE QUICK-PITCH™
1	20435	THROTTLE LEVER W/CABLE
4	1157 A	BUSHING
4	1162 A	LUBE CAP
4	1167 A	SCREW
4	1456	NUT
4	1875	WASHER
4	1322	SCREW
1	21046	GASKET KIT
1	21047	BEARING KIT
4	1247	RUBBER GROMMET
4	1245	SPACER
1	2827	ARM (16-1/2")
2	0152 1	BELT (A-30) (ROBIN)
1	10968	THRUST COLLAR KIT
2	0650140031	SPARK PLUG (ROBIN)
2	0430430015	TANK CAP (ROBIN)
2	2703261008	AIR CLEANER ELEMENT (ROBIN)

BA-SERIES TROWEL — NAMEPLATE AND DECALS

NAMEPLATES AND DECALS

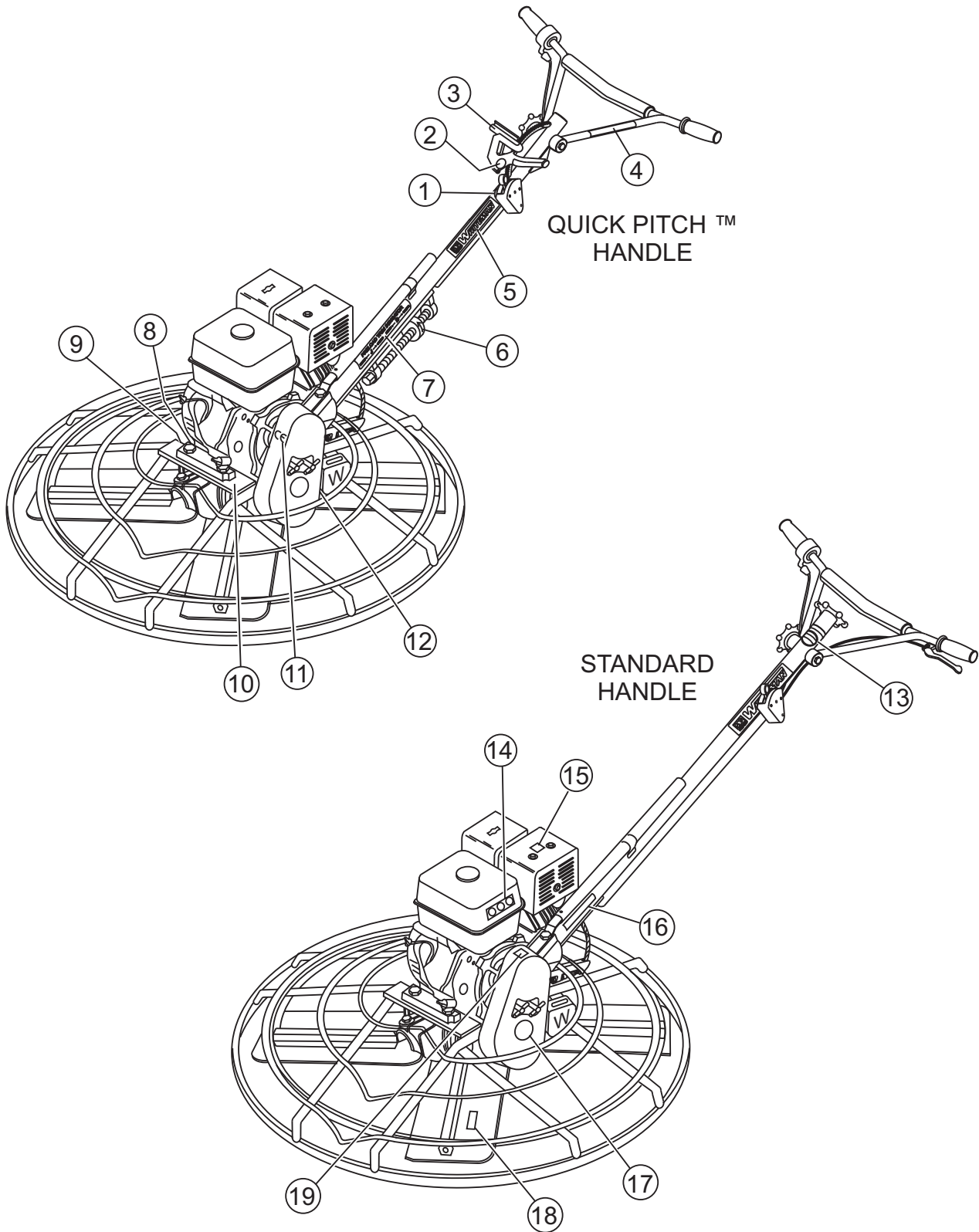

BA-SERIES TROWEL — NAMEPLATE AND DECALS

NAMEPLATE AND DECALS

<u>NO.</u>	<u>PART NO.</u>	<u>PART NAME</u>	<u>QTY.</u>	<u>REMARKS</u>
1	1758	DECAL: QUICK-PITCH™ HANDLE	1	
2	12405	DECAL: QUICK-PITCH™ HANDLE INSERT	2	
3	20527	DECAL: QUICK-PITCH™ WARNING	1	
4	20526	DECAL: QUICK-PITCH™ LATCH WARNING	1	
5	2942	DECAL: MQ WHITEMAN 13"	1	
6	1736	DECAL: ARROWS	1	
7	1735	DECAL: PRE-LOAD INDICATOR	1	
8*	11246	DECAL: OIL CHECK	1	
9		NAMEPLATE	1 CONTACT MULTIQUIP PARTS DEPT.
10	1940	DECAL: MQ WHITEMAN (SMALL)	1	
11	11092	DECAL: CE	1	
12*	11246	DECAL: GEAR DRIVE	1	
13	1492	DECAL: STANDARD HANDLE (FINISHER)	1	
14*	11247	DECAL: HELMET, FOOT AND GLOVE	1	
15*	11246	DECAL: HOT	1	
16	1261	DECAL: DO NOT LIFT	1	
17	1848	DECAL: POWER TROWEL	1	
18	2938	DECAL: METRIC	1	
19*	11246	DECAL: BELT DRIVE	1	
	12620	DECAL, KIT	1 INCLUDES ITEMS W/*

SEE DECAL ILLUSTRATIONS ON PAGE 12

BA-SERIE TROWEL — STANDARD HANDLE ASSY.

STANDARD HANDLE ASSY.

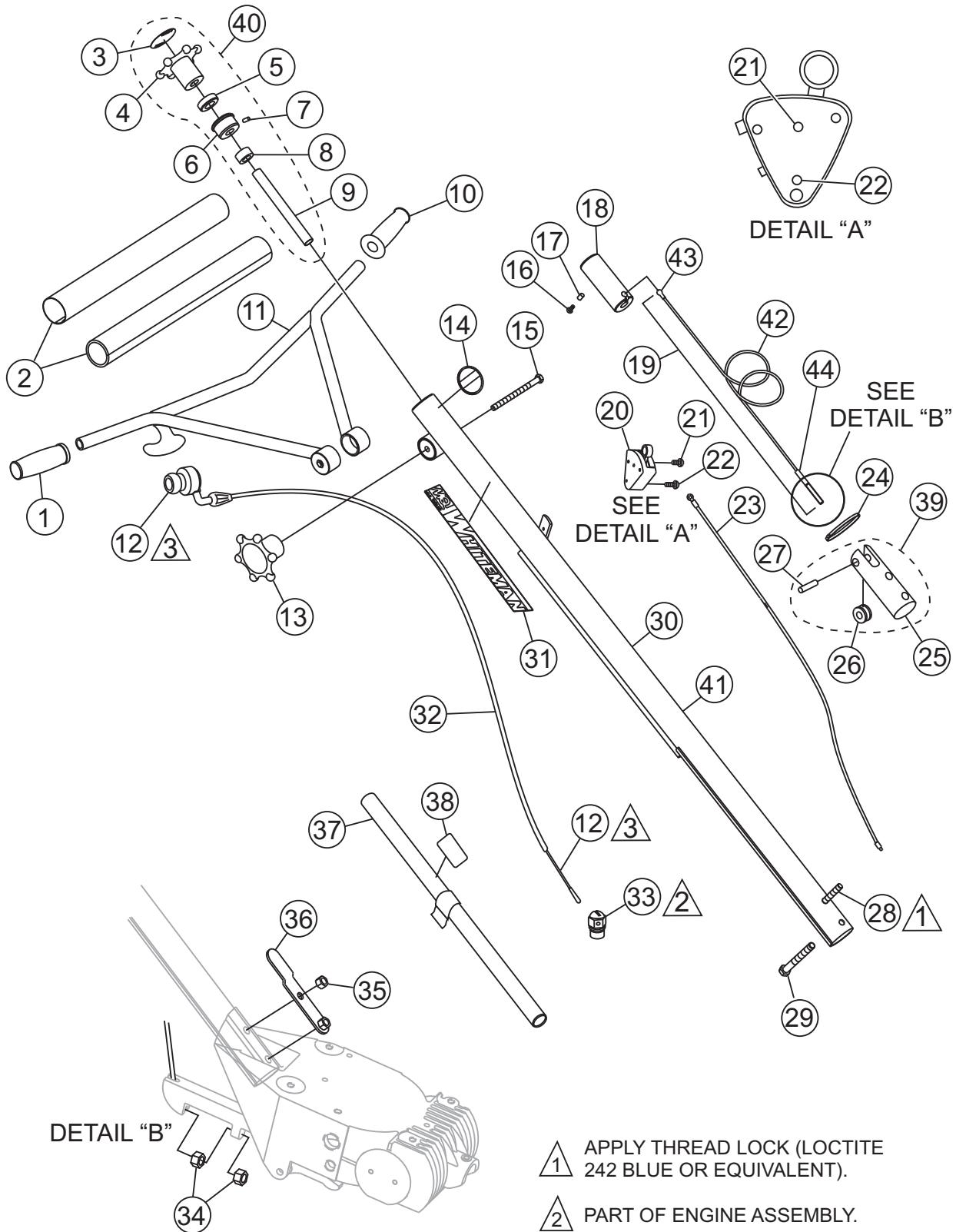

- ▲ 1 APPLY THREAD LOCK (LOCTITE 242 BLUE OR EQUIVALENT).
- ▲ 2 PART OF ENGINE ASSEMBLY.
- ▲ 3 CABLE IS ATTACHED TO THROTTLE AND SEALED AT THE FACTORY. ORDERABLE AS A UNIT ONLY.

BA-SERIES TROWEL — STANDARD HANDLE ASSY.

STANDARD HANDLE ASSY.

<u>NO.</u>	<u>PART NO.</u>	<u>PART NAME</u>	<u>QTY.</u>	<u>REMARKS</u>
1	20463	GRIP, HANDLE RIGHT	1	
2	20774	COVER, PAD HANDLE	1	
3*	20818	DECAL, STD PITCH	1	
4*	20817	WHEEL, HAND J-B HANDLE	1	
5*	0281	BEARING, THRUST, NICE 607	1	
6*	20282	BEARING, TROWEL CONTROL	1	
7*	0122C	SCREW, SHS 3/8-16 X 1/2	1	
8*	3615	COLLAR, SET 3/4 ID	1	
9*	1478	SHAFT, TROWEL CONTROL	1	
10	20478	GRIP, HANDLE LEFT	1	
11	12556	HANDLE, ADJUSTABLE	1	
12	20435	THROTTLE LEVER W/CABLE	1	
13	20439	WHEEL ASSY., HAND	1	
14	1492	DECAL, CUSTOM 2 1/2 CHROME	1	
15	20438	SCREW, HHC 3/8-16 X 5.00	1	
16	0786	SCREW, BHC 1/4- 20 X 3/8 NYL PATCH, NP	1	
17	0786A	SPACER, .360 X 17/64 X 1/8L	1	
18	20287	SLIDE BLOCK TROWEL CONTROL	1	
19	20285	CABLE ASSY., LENGTH 48.29" STD FINISHER	1	
20	20856	SWITCH ASSY., KILL	1	INCLUDES ITEMS W/\$
21\$	1602	SCREW, RHM 10-24 X 3/8	1	
22\$	20988	SCREW, FHSC PHILLIPS 8-32 X 1 1/4	1	
23	20514	WIRE ASSY., KILL SWITCH	1	
24	1662	TIE, CABLE TY-RAP, BLACK	1	
25#	20275	BLOCK, SUPPORT	1	
26#	1118	PULLEY, SUPPORT BLOCK	1	
27#	20279	PIN, SUPPORT BLOCK 3/8 X 1.59	1	
28	21017	SCREW, HHC 3/8-16 X 3 1/2 FULL THREAD	1	
29	1493	SCREW, HHC 3/8-16 X 3 1/4	1	
30	12567	HANDLE, STD	1	
31	2942	DECAL, MQ WHITEMAN, 13"	1	
32	20434	HOUSING, CABLE 74"	1	
33	20845	SWIVEL, THROTTLE CABLE	1	
34	1116	NUT, BRASS JAM 5/16-18	2	
35	10133	NUT, NYLOC 3/8-16	1	
36	20392	BRACKET, LIFT TUBE	1	
37		HANDLE, LIFT ASSY.	1	NO LONGER AVAILABLE
38		DECAL, CAUTION, LIFT HANDLE	1	NO LONGER AVAILABLE
39	20280	BLOCK, CABLE ASSY.	1	NCLUDES ITEMS W/#
40	20819	HAND WHEEL ASSY., PITCH CONTROL.	1	INCLUDES ITEMS W/*
41		HANDLE ASSY., STD FINISHERS	1	CONTACT SALES DEPT.
42■	20301	CABLE, CNTL 5/32 GALV AIRCRAFT 46.03"	1	
43■	20421	CLEVIS, BALL END CONTROL CABLE	1	
44■	A8638	END-BOLT, CNTL CABLE	1	

BA-SERIES TROWEL — QUICK-PITCH™ HANDLE ASSY.

QUICK-PITCH™ T-HANDLE

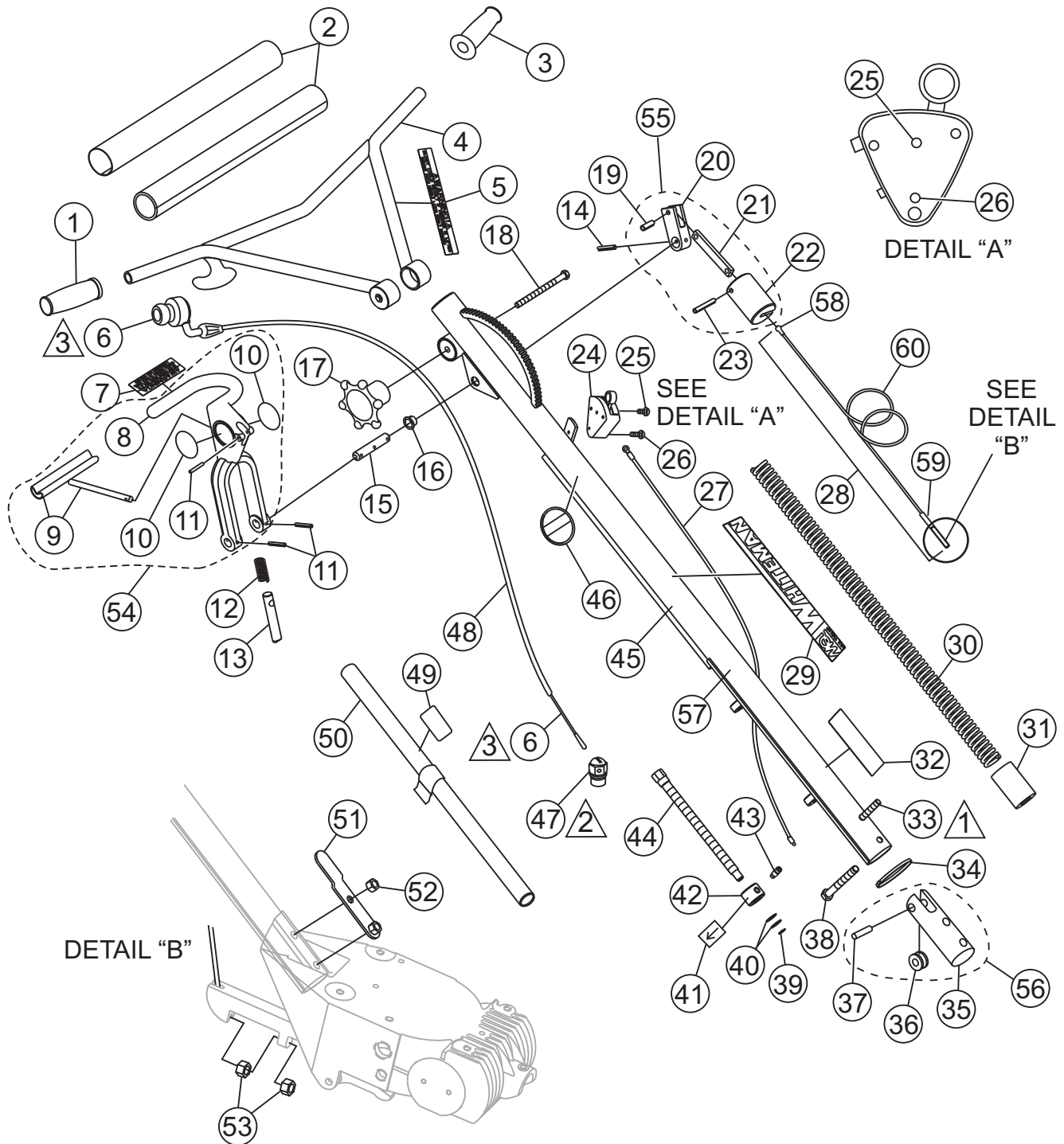

1 APPLY THREAD LOCK (LOCTITE 242 BLUE OR EQUIVALENT).

2 PART OF ENGINE ASSEMBLY.

3 CABLE IS ATTACHED TO THROTTLE AND SEALED AT THE FACTORY. ORDERABLE AS A UNIT ONLY.

BA-SERIES TROWEL — QUICK-PITCH™ HANDLE ASSY.

QUICK-PITCH HANDLE

<u>NO.</u>	<u>PART NO.</u>	<u>PART NAME</u>	<u>QTY.</u>	<u>REMARKS</u>
1	20463	GRIP, HANDLE RIGHT	1	
2	20774	COVER, PAD HANDLE	1	
3	20478	GRIP, HANDLE LEFT	1	
4	12556	HANDLE, ADJUSTABLE	1	
5	20526	DECAL, LATCH WARNING	1	
6	20435	THROTTLE, J-B	1	
7	20527	DECAL, Q.P. WARNING	1	
8*	20389	HANDLE, QUICK-PITCH™	1	
9*	1746	TRIGGER, QP CHROMED	1	
10*	12405	DECAL, WHITEMAN QUICK-PITCH™	2	
11*	1729	PIN, ROLL 3/16 X 1 1/4	3	
12*	1706	SPRING, ENCLOSED QP CLAMP	1	
13*	20437	PIN, QP LATCH	1	
14	4568	PIN, ROLL 3/16 X 1	1	
15	1711	SHAFT, CONTROL QP	1	
16	1719	BUSHING, PIVOT PLATE	1	
17	20439	WHEEL ASSY., HAND	1	
18	20438	SCREW, HHC 3/8-16 X 5.00	1	
19+	1731	PIN, ROLL 1/4 X 3/4	1	
20+	20443	ARM, SLIDE CONTROL	1	
21+	1709	CONNECTOR, QP CONTROL ARM	1	
22+	20269	LINKAGE, QP CONTROL	1	
23+	20276	PIN, ROLL 1/4 X 1 3/4	1	
24	20856	SWITCH ASSY., KILL	1	INCLUDES ITEMS W/\$
25\$	1602	SCREW, RHM 10-24 X 3/8	1	
26\$	20988	SCREW, FHSC PHILLIPS 8-32 X 1 1/4	1	
27	20514	WIRE ASSY., KILL SWITCH	1	
28	20297	CABLE ASSY., QP CONTROL, 45"	1	INCLUDES ITEMS W/■
29	2942	DECAL, MQ WHITEMAN, 13"	1	
30	1715	SPRING, COUNTER BALANCE	1	
31	20270	BLOCK, QP ADJUSTMENT	1	
32	1735	DECAL, PRELOAD TRIM INDICATOR	1	
33	21017	SCREW, HHC 3/8-16 X 3 1/2 FULL THREAD	1	
34	1662	TIE, CABLE, TY-RAP BLACK	1	
35#	20275	BLOCK, SUPPORT	1	
36#	1118	PULLEY, SUPPORT BLOCK	1	
37#	20279	PIN, SUPPORT BLOCK 3/8 X 1.59	1	
38	1493	SCREW, HHC 3/8-16 X 3 1/4	1	
39	1737	SNAP RING, TRUARC #5100-50	1	
40	1733	WASHER, 1/2 X 1/32, HARDENED	2	

BA-SERIE TROWEL — QUICK PITCH™ HANDLE ASSY.

QUICK PITCH HANDLE

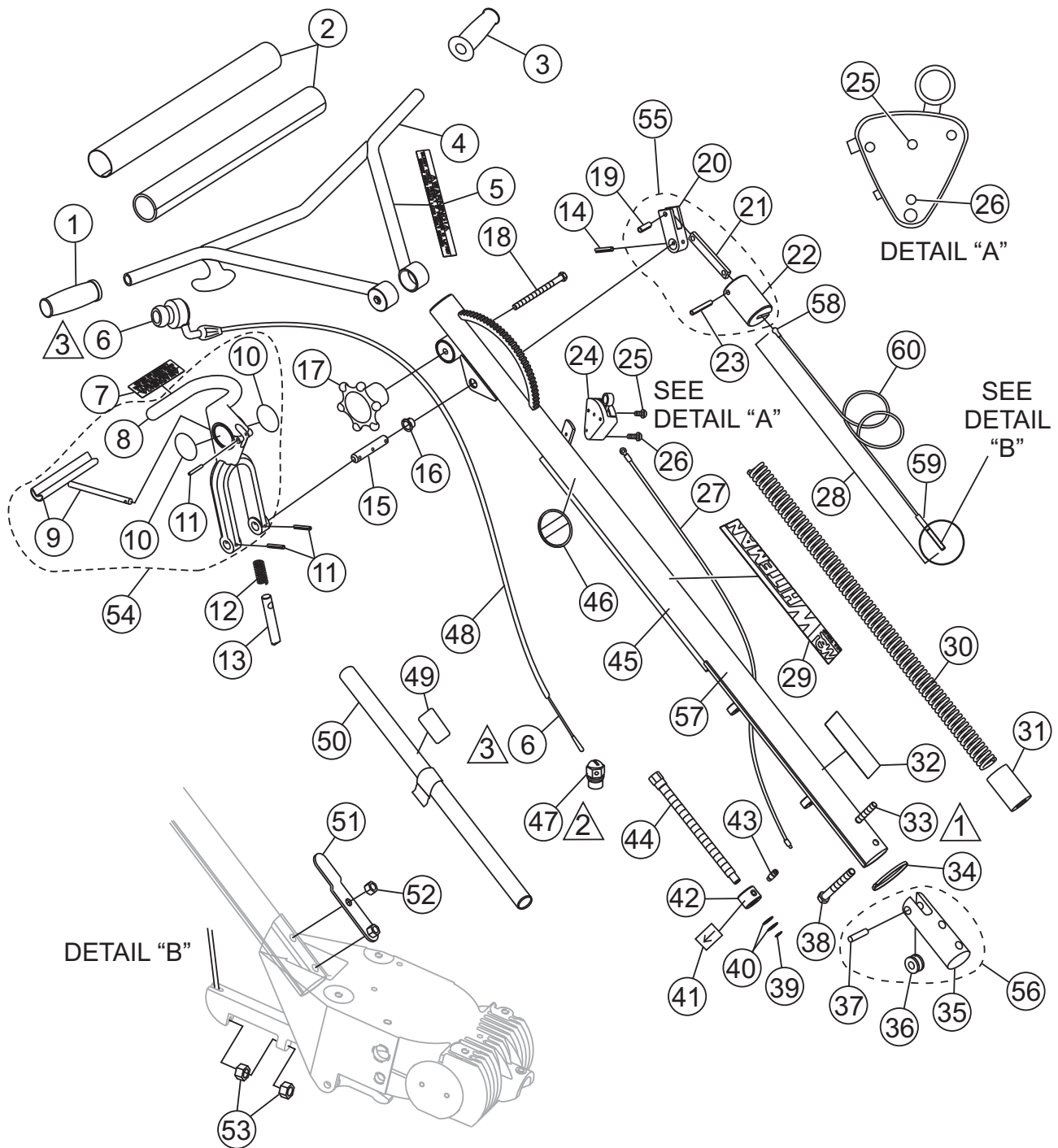

▲ 1 APPLY THREAD LOCK (LOCTITE 242 BLUE OR EQUIVALENT).

▲ 2 PART OF ENGINE ASSEMBLY.

▲ 3 CABLE IS ATTACHED TO THROTTLE AND SEALED AT THE FACTORY. ORDERABLE AS A UNIT ONLY.

BA-SERIES TROWEL — QUICK PITCH™ HANDLE ASSY.

QUICK PITCH HANDLE

<u>NO.</u>	<u>PART NO.</u>	<u>PART NAME</u>	<u>QTY.</u>	<u>REMARKS</u>
41	1736	DECAL, ARROW	1	
42	1718	NUT, QP TRIM CTRL ADJ	1	
43	1732	BOLT, STRIPPER 3/8 X 1/2	1	
44	1717	SCREW, QP TRIM ADJUSTMENT	1	
45	12642	TUBE, MAIN HANDLE	1	
46	1758	DECAL, PATENT QP	1	
47	20845	SWIVEL, ENGINE THROTTLE CABLE	1	
48	20434	HOUSING, THROTTLE CABLE 74"	1	
49		DECAL, CAUTION, LIFT HANDLE	1	NO LONGER AVAILABLE
50		HANDLE, LIFT ASSY.	1	NO LONGER AVAILABLE
51	20392	BRACKET, LIFT TUBE	1	
52	10133	NUT, NYLOC 3/8-16	1	
53	1116	NUT, BRASS JAM 5/16-18	2	
54	20390	TRIGGER, QP ASSY.	1	INCLUDES ITEMS W/*
55	20293	LINKAGE, QP CONTROL ASSY.	1	INCLUDES ITEMS W/+
56	20280	BLOCK, CABLE ASSY.	1	INCLUDES ITEMS W/#
57		HANDLE ASSY., MAIN	1	CONTACT SALES DEPT.
58■	20421	CLEVIS, BALL END CONTROL CABLE	1	
59■	A8638	END-BOLT, CNTRL CABLE	1	
60■	20271	CABLE, CNTL 5/32 GALV AIRCRAFT 43.19"	1	

BA-SERIE TROWEL — THRUST BEARING KIT ASSY.

THRUST BEARING KIT ASSEMBLY.

THRUST BEARING KIT No. 10968

OLD STYLE THRUST BEARING NO LONGER USED

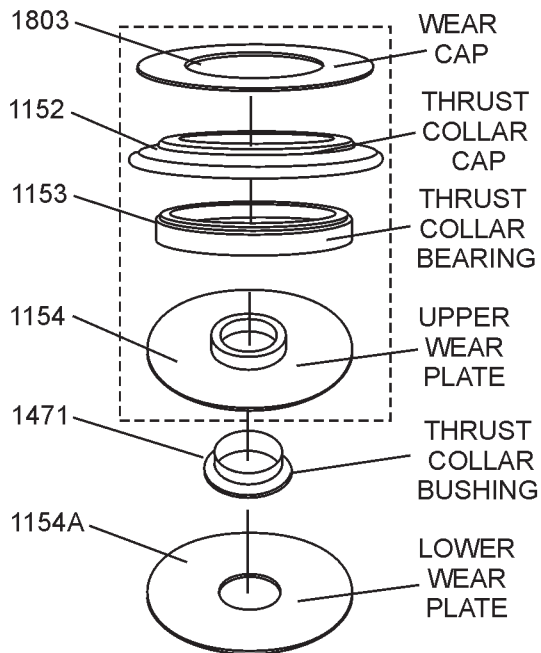

NEW STYLE THRUST BEARING

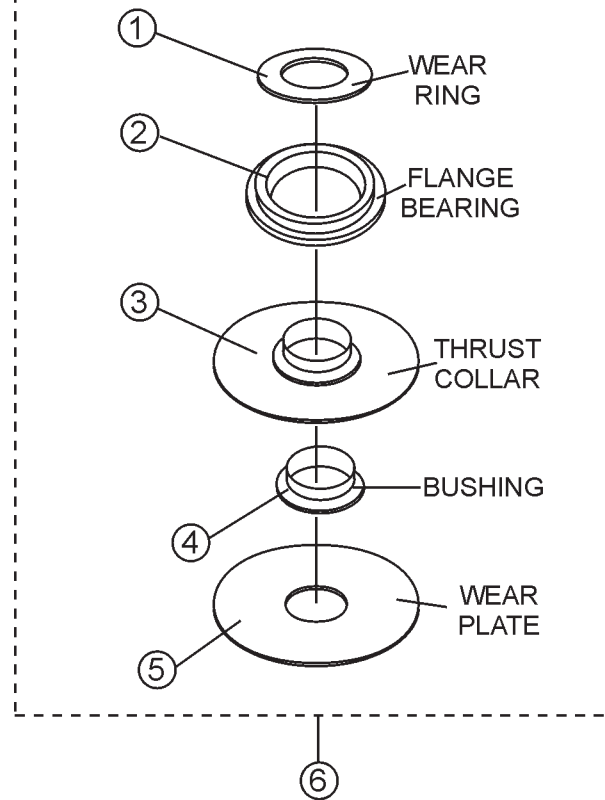

WHEN RE-ORDERING ***MUST*** USE
THRUST BEARING KIT P/N 10968.
OLD STYLE IS NOT AVAILABLE.

BA-SERIES TROWEL — THRUST BEARING KIT ASSY.

THRUST BEARING KIT ASSEMBLY.

<u>NO.</u>	<u>PART NO.</u>	<u>PART NAME</u>	<u>QTY.</u>	<u>REMARKS</u>
1*	12208	WEAR RING	1	
2*	12778	FLANGE BEARING	1	
3*	10793	THRUST COLLAR W/BUSHING	1	
4*	1471	BUSHING	1	
5*	1154A	LOWER WEAR PLATE	1	
6	10968	THRUST BEARING KIT	1	INCLUDES ITEM W/*

BA-SERIES TROWEL — 4-BLADE SPIDER ASSY.

4 BLADE SPIDER ASSY.

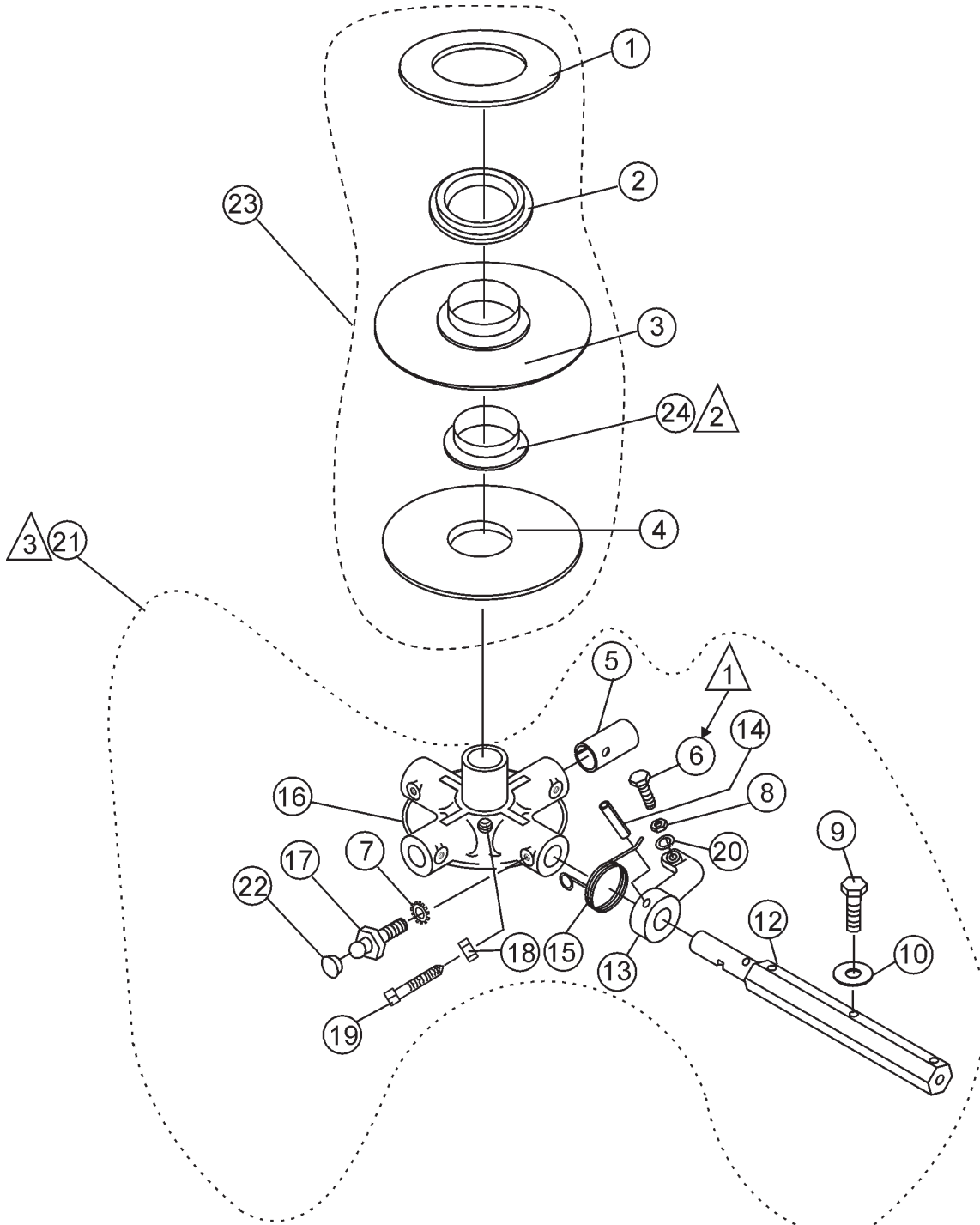

NOTES:

- ① APPLY LOCTITE P/N 1477
- ② INCLUDED WITH ITEM 3 OR CAN BE ORDERED SEPARATELY(P/N 1471).
- ③ SPIDER ASSEMBLIES P/N 1489 AND 1490 INCLUDES ALL ITEMS WITHIN OUTLINE.

BA-SERIES TROWEL — 4-BLADE SPIDER ASSY.

4 BLADE SPIDER ASSY.

<u>NO.</u>	<u>PART NO.</u>	<u>PART NAME</u>	<u>QTY.</u>	<u>REMARKS</u>
1*	12208	WEAR RING	1	
2*	12778	FLANGE BEARING	1	
3*	10793	THRUST COLLAR	1	INCLUDES ITEMS W/#
4*	1154A	WEAR PLATE	1	
5\$	1157A	BEARING INSERT	4	
6\$	0164B	RADIUS HEAD 3/8- 16 x 1-1/4"	4	
7\$	1875	INT. SHKP. WASHER 3/8"	4	
8\$	1876	JAM NUT 3/8- 16	4	
9\$	0105	HHCS 5/16- 18 x 1-1/2"	8	
10\$	0161C	LOCK WASHER 5/16"	8	
12\$	2827	TROWEL ARM EXTENDED, 16-1/2"	4	
13\$	1163	TROWEL ARM LEVER	4	
14\$	4164	ROLL PIN 5/16 x 1-3/4"	4	
15\$	1316	SPRING (RIGHT HAND)	4	
16\$	1161	SPIDER PLATE ONLY	1	
17\$	1322	RETAINING SCREW ASSY.	4	
18\$	1456	HEX NUT 3/8-16	1	
19\$	1167A	SHSS 3/8-16 x 1-1/2" CONE POINT	1	
20\$	0166A	LOCK WASHER 3/8"	4	
21	1490	SPIDER PLATE ASSY. (4 BLADE)	1	INCLUDES ITEMS W/\$
22	1162A	LUBRA- CAP	4	
23	10968	THRUST BEARING KIT	1	INCLUDES ITEMS W/*
24*#	1471	THRUST COLLAR BUSHING	1	

BA-SERIES TROWEL — GEARBOX AND ENGINE MOUNTS ASSY.

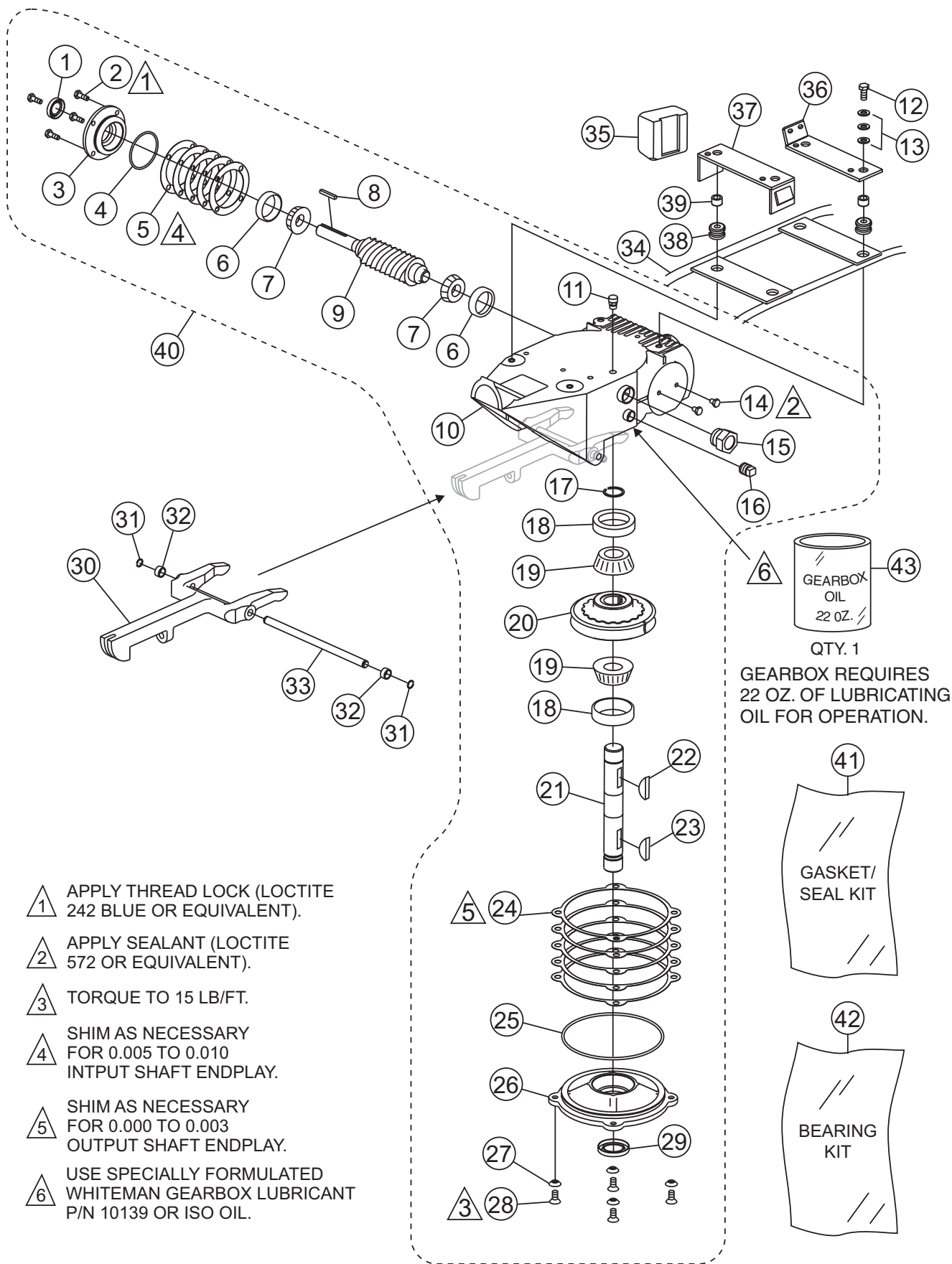

- ▲ 1 APPLY THREAD LOCK (LOCTITE 242 BLUE OR EQUIVALENT).
- ▲ 2 APPLY SEALANT (LOCTITE 572 OR EQUIVALENT).
- ▲ 3 TORQUE TO 15 LB/FT.
- ▲ 4 SHIM AS NECESSARY FOR 0.005 TO 0.010 INPUT SHAFT ENDPLAY.
- ▲ 5 SHIM AS NECESSARY FOR 0.000 TO 0.003 OUTPUT SHAFT ENDPLAY.
- ▲ 6 USE SPECIALLY FORMULATED WHITEMAN GEARBOX LUBRICANT P/N 10139 OR ISO OIL.

QTY. 1
 GEARBOX REQUIRES
 22 OZ. OF LUBRICATING
 OIL FOR OPERATION.

GASKET/
 SEAL KIT

BEARING
 KIT

BA-SERIE TROWEL — GEARBOX AND ENGINE MOUNTS ASSY.

GEARBOX AND ENGINE MOUNTS ASSY.

<u>NO.</u>	<u>PART NO.</u>	<u>PART NAME</u>	<u>QTY.</u>	<u>REMARKS</u>
1%*	0753	SEAL, OIL NATIONAL #470954	1	
2%	0131A	SCREW, HHC 1/4-20 X 3/4	4	
3%	12876	FLANGE, INPUT SHAFT	1	
4%*	20395	RING, O -139 BUNA N	1	
5%*	20397	SHIM, INPUT 0.002 THICK	1	
	20398	SHIM, INPUT 0.003 THICK	1	
	20399	SHIM, INPUT 0.005 THICK	1	
	20400	SHIM, INPUT 0.010 THICK	1	
	20401	SHIM, INPUT 0.020 THICK	1	
6%#	20466	BEARING, CUP, TIMKEN #LM11910	2	
7%#	20465	BEARING, CONE, TIMKEN #LM11949	2	
8%	0627	KEY, SQUARE 3/16 X 1 1/4	1	
9%	1851	GEAR, WORM & SHAFT ASSY.	1	
10%	12874	CASE, GEAR, J, B FINISHER	1	
11%	1132	VENT, AIR	1	
12	0655	SCREW, HHC 5/16-18 X 3/4	1	
13	0300B	WASHER, FLAT 5/16 SAE	3	
14%	20476	SCREW, HHC 1/4-28 X 3/8	2	
15%	21033	SIGHT GLASS, 3/4 M PIPE STEEL	1	
16%	0121A	FITTING, PLUG 3/8 MP SQ HEAD	1	
17%	1138	RING, SNAP, TRUARC 5100-112	1	
18%#	20475	BEARING, CUP TIMKEN #M86610	2	
19%#	20474	BEARING, CONE TIMKEN #M86647	2	
20%	1140	GEAR, WORM, BRONZE	1	
21%	20470	SHAFT, OUTPUT J/B FIN	1	
22%	1139	KEY, WOODRUFF #21 HARDENED	1	
23	1238	KEY, WOODRUFF #25	1	
24%*	20402	SHIM, OUTPUT 0.002 THICK	1	
	20403	SHIM, OUTPUT 0.003 THICK	1	
	20404	SHIM, OUTPUT 0.005 THICK	1	
	20405	SHIM, OUTPUT 0.010 THICK	1	
	20406	SHIM, OUTPUT 0.020 THICK	1	
25%*	20396	RING, O -257 BUNA N	1	
26%	12875	COVER, GEARBOX	1	
27%	10235	WASHER, C/S EXT. SHKP	4	
28%	1146	SCREW, FHSC 5/16-18 X 1, NYLOC NP	4	
29%*	0254	SEAL, OIL, NATIONAL #470712	1	
30	1150	ARM, YOKE	1	
31	20802	RING, SNAP, TRUARC 5100-37 OR EQUIV.	2	
32	20803	SPACER, .50 OD X .40 ID X 0.25L	2	
33	20801	PIN, YOKE	1	
34	20811	STATIONARY GUARD RING	1	
35	1810	WEIGHT	2	

BA-SERIES TROWEL — GEARBOX AND ENGINE MOUNTS ASSY.

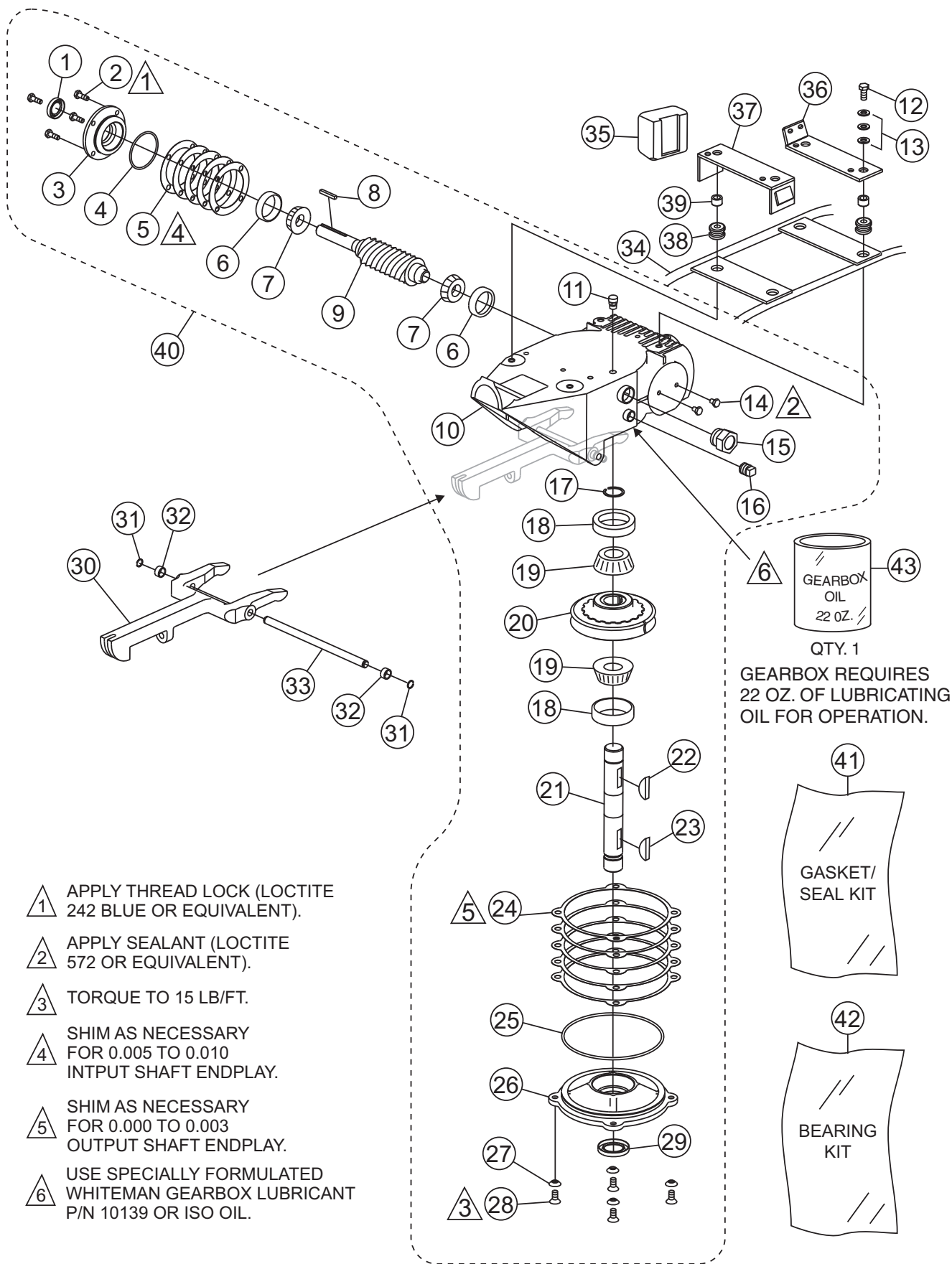

- ▲ 1 APPLY THREAD LOCK (LOCTITE 242 BLUE OR EQUIVALENT).
- ▲ 2 APPLY SEALANT (LOCTITE 572 OR EQUIVALENT).
- ▲ 3 TORQUE TO 15 LB/FT.
- ▲ 4 SHIM AS NECESSARY FOR 0.005 TO 0.010 INPUT SHAFT ENDPLAY.
- ▲ 5 SHIM AS NECESSARY FOR 0.000 TO 0.003 OUTPUT SHAFT ENDPLAY.
- ▲ 6 USE SPECIALLY FORMULATED WHITEMAN GEARBOX LUBRICANT P/N 10139 OR ISO OIL.

QTY. 1
 GEARBOX REQUIRES
 22 OZ. OF LUBRICATING
 OIL FOR OPERATION.

GASKET/
 SEAL KIT

BEARING
 KIT

BA-SERIE TROWEL — GEARBOX AND ENGINE MOUNTS ASSY.

GEARBOX AND ENGINE MOUNTS ASSY.

<u>NO.</u>	<u>PART NO.</u>	<u>PART NAME</u>	<u>QTY.</u>	<u>REMARKS</u>
36	1958	FRONT ENGINE MOUNT (HONDA)	1	
36	1965	FRONT ENGINE MOUNT (ROBIN)	1	
36	20536	FRONT ENGINE MOUNT (BRIGGS)	1	
37	1964	REAR ENGINE MOUNT (HONDA 8HP)	1	
37	20954	REAR ENGINE MNT. (HONDA W/HAND CLUTCH)	1	
37	20545	REAR ENGINE MOUNT (ROBIN)	1	
37	20558	REAR ENGINE MOUNT (BRIGGS)	1	
38	1247	GROMMET 1/4 X .875 ID X 1-5/8 OD	4	
39	1245	BUSHING, GUARD RING	4	
40	20407	GEARBOX ASSY.	1	INCLUDES ITEMS W/%
41	21046	GASKET/SEAL KIT	1	INCLUDES ITEMS W/★
42	21047	BEARING KIT	1	INCLUDES ITEMS W/#
43	10139	GEARBOX OIL, 22 OZ.	1	

BA-SERIES TROWEL — ENGINES, HONDA, ROBIN, BRIGGS & STRATTON

ENGINES, 8 HP HONDA, 8 HP ROBIN, & 8 HP BRIGGS AND STRATTON ASSY.

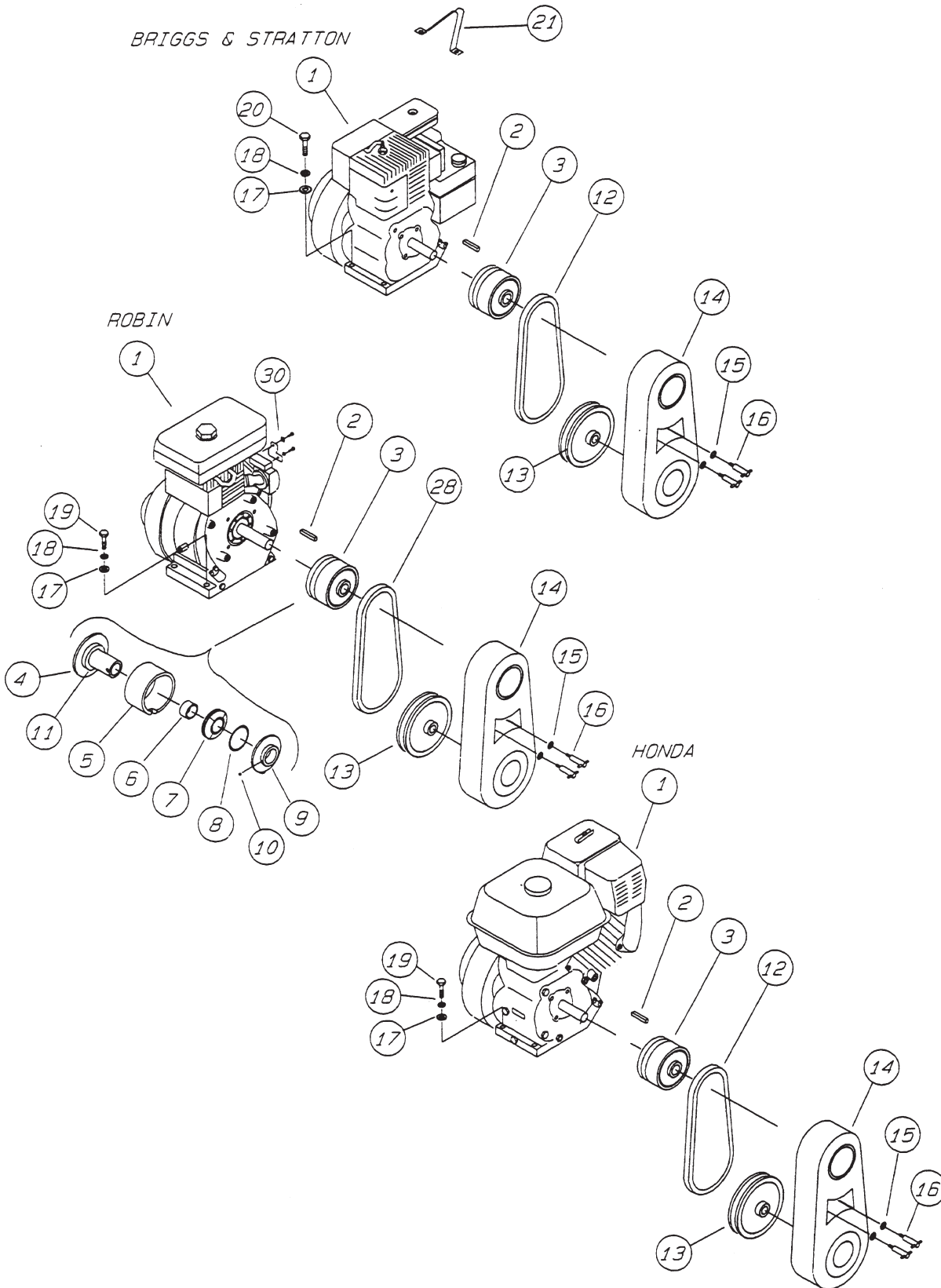

BA-SERIES TROWEL — ENGINES, HONDA, ROBIN, BRIGGS & STRATTON

ENGINES, 8 HP HONDA, 8 HP ROBIN, & 8 HP BRIGGS AND STRATTON ASSY.

<u>NO.</u>	<u>PART NO.</u>	<u>PART NAME</u>	<u>QTY.</u>	<u>REMARKS</u>
1	1387	ENGINE 8HP HONDA	1	
1	20469	ENGINE 8HP BRIGGS & STRATTON	1	
1	1256	ENGINE 8HP ROBIN	1	
2	0310	SQUARE KEY 1/4X1/4X1.1/2"	1	
3	0250	AUTOMATIC CLUTCH ASSY. 1" BORE	1 INCLS. ALL ITEMS W/*
4*	0252	SPINDLE 1" BORE	1	
5*	0251	CLUTCH HOUSING DRUM	1	
6*	0458	CLUTCH HOUSING DRUM BUSHING	1	
7*	B1766	WEIGHT, CLUTCH	1 REPLACES P/N 0454
8*	0855	SPRING	1	
9*	0253	CLUTCH EXPANSION PLATE	1	
10*	1868	SCREW, SHS 3/8-24 X 3/4, NOPLT	1 REPLACES P/N 0457
11*	0456	BELT RUNNER (BEARING)	1	
12	0261	BELT (A31)(HONDA,B&S)	1	
13	1127	PULLEY	1	
14	1335	BELT GUARD	1	
15	0181B	LOCKWASHER 1/4"	2	
16	2577	T-BOLT 1/4-20	2	
17	0300B	FLAT WASHER 5/16"	4	
18	0161C	LOCKWASHER 5/16"	4	
19	10181	HHCS 5/16-24 x 1-1/4"	4	
20	1391	HHCS 5/16-24 x 1-1/2"	4	
21		LIFT STRAP	1 CONTACT UNIT SALES DEPT./ACCESSORY ITEM
28	0152 1	BELT (A30) GATES (ROBIN)	1	

BA-SERIES TROWEL — HAND CLUTCH ASSY.

HAND CLUTCH ASSY.

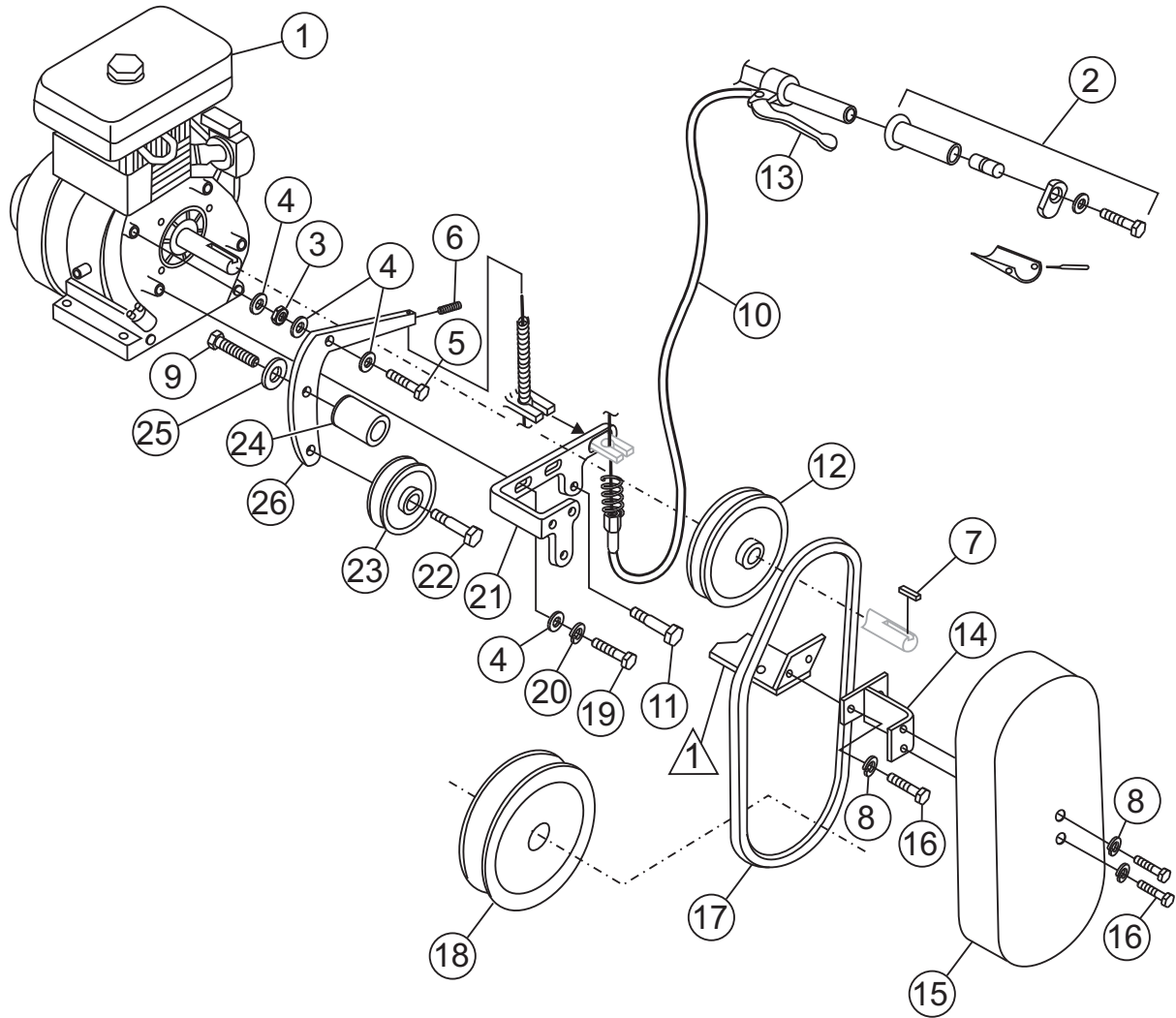

⚠ SEE GEARBOX AND ENGINE MOUNTS ITEM 36 PAGE 52.

BA-SERIES TROWEL — HAND CLUTCH ASSY.

HAND CLUTCH ASSY.

<u>NO.</u>	<u>PART NO.</u>	<u>PART NAME</u>	<u>QTY.</u>	<u>REMARKS</u>
1	1387	ENGINE DRIVE ASSY. 8 HP HONDA	1	
2	10036	CLUTCH ASSIST HANDLE ASSY.	1	
3	6014C	HEX FINISH NUT 5/16-24	1	
4	0300B	FLAT WASHER 5/16"	5	
5	10181	SCREW, HHC 5/16-24X1.1/4"	1	
6	10450	SHSS 10-32X1/4"	1	
7	0310	KEY, CLUTCH 1/4 x 1/4 x 1.1/2"	1	
8	0181B	LOCK WASHER 1/4"	4	
9	1672	SCREW, HHC 3/8-24 x 1"	1	
10	10936	HAND CLUTCH CABLE ASSY.	1	
11	10971	SHOULDER BOLT 5/16X1.1/2"	1	
12	2469	PULLEY,ENGINE	1	
13	1512	HAND CLUTCH CONTROL LEVER	1	
14	10831	BELT GUARD MOUNT	1	
15	10833	BELT GUARD	1	
16	0730	HHCS 1/4-20X1"	4	
17	0262	BELT,(A33)(HONDA)	1	
18	1127	PULLEY,DRIVEN(HONDA)	1	
19	10229	HHCS 5/16-24X1"	2	
20	0161C	LOCK WASHER 5/16"	2	
21	10898	CLUTCH BRKT.	1	
22	10281	BOLT, SHOULDER 3/8-x 1.1/2"	1	
23	10935	PULLEY,IDLER	1	
24	20981	SHOE, BELT HAND CLUTCH	1	
25	13351	WASHER, FLAT 3/8 USS EXT THK HI STR	1	
26	10822	CLUTCH IDLER LEVER	1	

BA-SERIE TROWEL — GUARD RING ASSY.

GUARD RING ASSY.

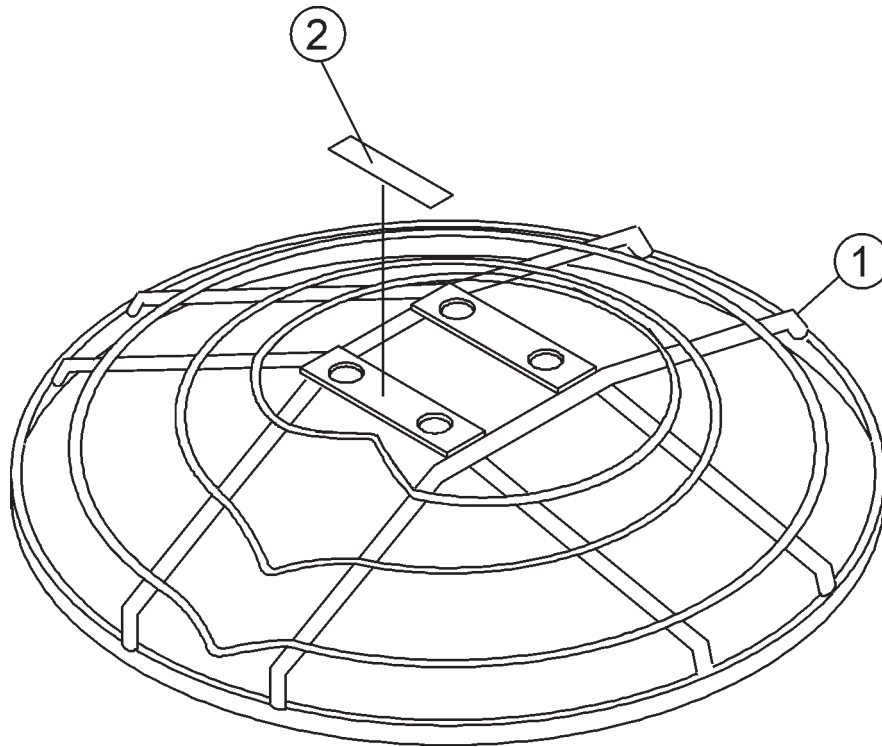

BA-SERIES TROWEL — GUARD RING ASSY.

GUARD RING ASSY.

<u>NO.</u>	<u>PART NO.</u>	<u>PART NAME</u>	<u>QTY.</u>	<u>REMARKS</u>
1	20797	STATIONARY GUARD RING	1	
2	1489	SPIDER PLATE ASSY 16-1/2" ARM (EXT)	1	3-BLADE MODEL
2	1490	SPIDER PLATE ASSY 16-1/2" ARM (EXT)	1	4-BLADE MODEL

BA-SERIES TROWEL — STABILIZER RING ASSY.

STABILIZER RING ASSY.

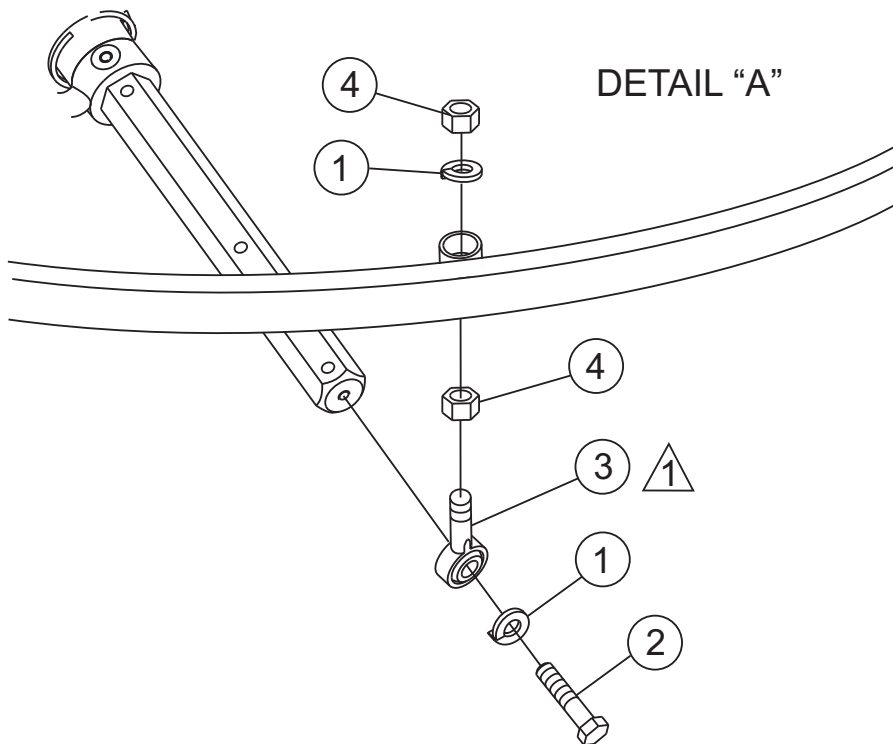
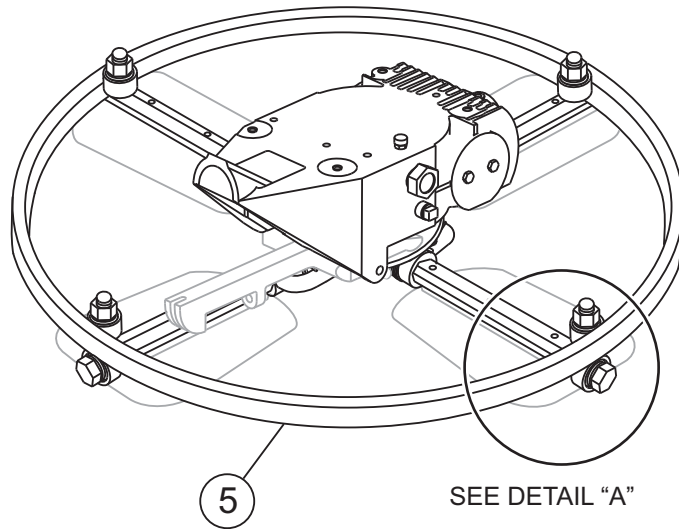

△ 1 APPLY LOCTITE 242 BLUE OR EQUIVALENT.

BA-SERIES TROWEL — STABILIZER RING ASSY.

STABILIZER RING ASSY.

<u>NO</u>	<u>PART NO</u>	<u>PART NAME</u>	<u>QTY.</u>	<u>REMARKS</u>
1	0161C	WASHER, LOCK, 5/16 MED	4	
2	1237	SCREW, SCH 5/16-18 X 7/8, NYL, NP	4	
3	1723	ROD END, 5/16-24 MALE	4	
4	6014C	NUT, HEX FINISH 5/16-24	8	
5	1482	RING, STABILIZER, 14-1/2" ARM	1	3-BLADE MODEL, REPLACES P/N 1234
5	1483	RING, STABILIZER, 14-1/2" ARM	1	4-BLADE MODEL, REPLACES P/N 1235

BA-SERIES TROWEL — BLADES & ADJUSTMENT FIXTURE ASSY.

BLADES & ADJUSTMENT FIXTURE ASSY.

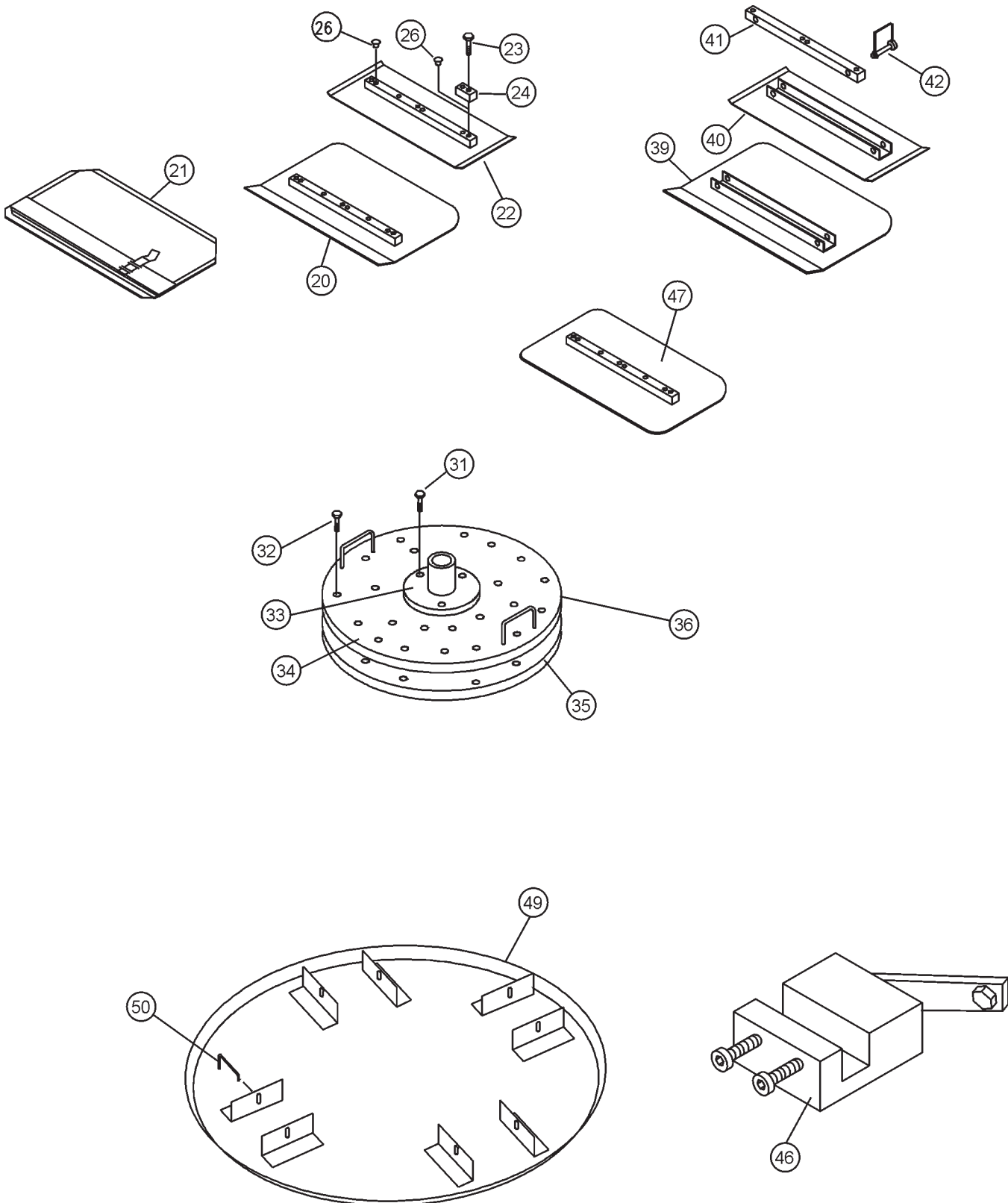

BA-SERIES TROWEL — BLADES & ADJUSTMENT FIXTURE ASSY.

BLADES & ADJUSTMENT FIXTURE ASSY.

<u>NO.</u>	<u>PART NO.</u>	<u>PART NAME</u>	<u>QTY.</u>	<u>REMARKS</u>
20		COMBO FLOAT & FINISH BLADE	3,4	CONTACT UNIT SALES DEPT./ACCESSORY ITEM
20		ENDURO COMBO FLOAT & FINISH BLADE	3,4	CONTACT UNIT SALES DEPT./ACCESSORY ITEM
21		FLOAT BLADE	3,4	CONTACT UNIT SALES DEPT./ACCESSORY ITEM
22		FINISH BLADE	3,4	CONTACT UNIT SALES DEPT./ACCESSORY ITEM
22		ENDURO FINISH BLADE W/ROTATING	3,4	CONTACT UNIT SALES DEPT./ACCESSORY ITEM
23	0202	HHCS 5/16-18X1" RING	3,4	
24	0201	GUARD RING LUG RING	3,4	
26	1434	TROWEL LUG (FINISH BLADE ONLY)	3,4	
27	1162A	LUBRA-CAP	3,4	
28	1482	STABILIZER RING 14 1/2" ARM (B-3 MODEL)	1	
28	1483	STABILIZER RING 14 1/2" ARM (B-4 MODEL)	1	
29	6014C	HEX NUT 5/16-24	6,8	
30	1237	HHCS 5/16-18X7/8" NY-LOC	3,4	
31	0490	SHCS 7/16-14X1"	3	
32	0487	SHCS 3/8-16X1/2"	20	
33	0489	GRINDING DISC HUB	1	
34	0488	STONE MOUNT PLATE	1	
35		GRINDING DISC STONE ONLY	1	CONTACT UNIT SALES DEPT./ACCESSORY ITEM
36		GRINDING DISC ASSY.	1	CONTACT UNIT SALES DEPT./ACCESSORY ITEM
39		UNIVERSAL COMBO BLADE	3,4	CONTACT UNIT SALES DEPT./ACCESSORY ITEM
39		ENDURO UNIVERSAL COMBO BLADE	3,4	CONTACT UNIT SALES DEPT./ACCESSORY ITEM
40		UNIVERSAL FINISH BLADE	3,4	CONTACT UNIT SALES DEPT./ACCESSORY ITEM
40		ENDURO UNIVERSAL FINISH BLADE	3,4	CONTACT UNIT SALES DEPT./ACCESSORY ITEM
41		UNIVERSAL MOUNTING BAR	3,4	CONTACT UNIT SALES DEPT./ACCESSORY ITEM
42		SNAP PIN 1/4"X1.3/4"	6,8	CONTACT UNIT SALES DEPT./ACCESSORY ITEM
44	0166A	LOCK WASHER 3/8"	3,4	
46		TROWEL ARM ADJ. FIXTURE ASSY.	1	CONTACT UNIT SALES DEPT./ACCESSORY ITEM
47		REVERSIBLE COMBO BLADE	3,4	CONTACT UNIT SALES DEPT./ACCESSORY ITEM
48	1723	MALE R.H. ROD END 5/16"	1	
49		FLOAT DISC	1	CONTACT UNIT SALES DEPT./ACCESSORY ITEM
50		FLOAT DISC LATCH PIN	4	CONTACT UNIT SALES DEPT./ACCESSORY ITEM

BA-SERIES TROWEL — LIFTING BALE ASSY. (OPTION)

LIFTING BALE ASSY. (OPTION)

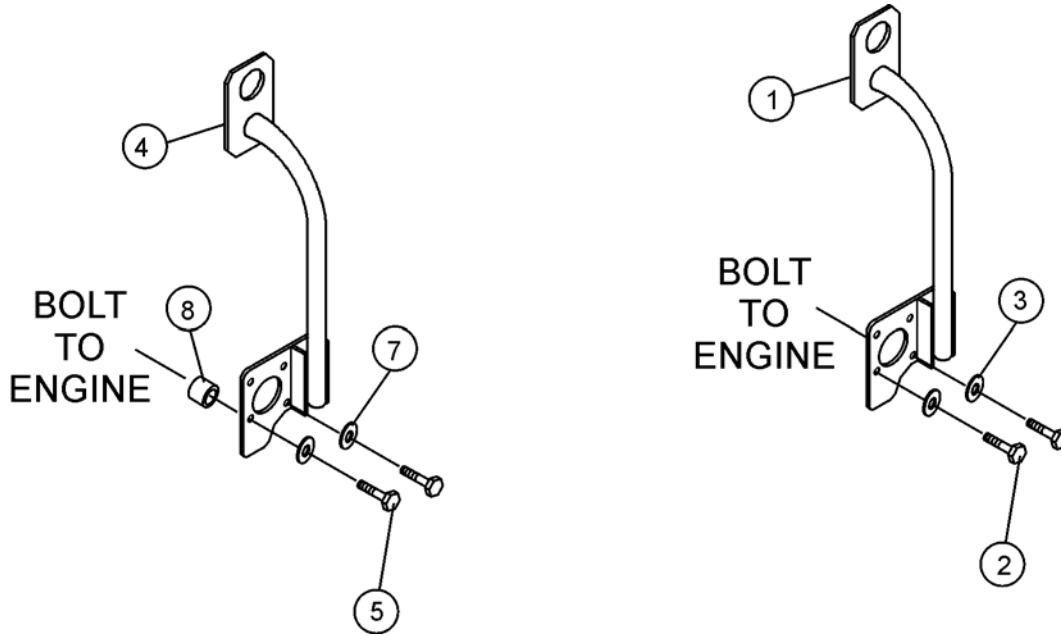

BA-SERIES TROWEL — LIFTING BALE ASSY. (OPTION)

LIFTING BALE ASSY. (OPTION)

<u>NO.</u>	<u>PART NO.</u>	<u>PART NAME</u>	<u>QTY.</u>	<u>REMARKS</u>
1		LIFTING BALE ASSY.	1	CONTACT UNIT SALES DEPT./ACCESSORY ITEM
2	10229	HHCS 5/16-24X1"	4	
3	0161C	LOCK WASHER 5/16"	4	
4		LIFTING BALE ASSY.	1	CONTACT UNIT SALES DEPT./ACCESSORY ITEM
5	0205	HHCS 3/8-16X1"	3	
6	1394	FHSCS 3/8-16X1"	1	
7	0166A	LOCK WASHER 3/8"	3	
8	1897	SPACER (ROBIN ENGINE)	4	

HONDA GX240K1QA2 ENGINE — AIR CLEANER ASSY.

AIR CLEANER ASSY.

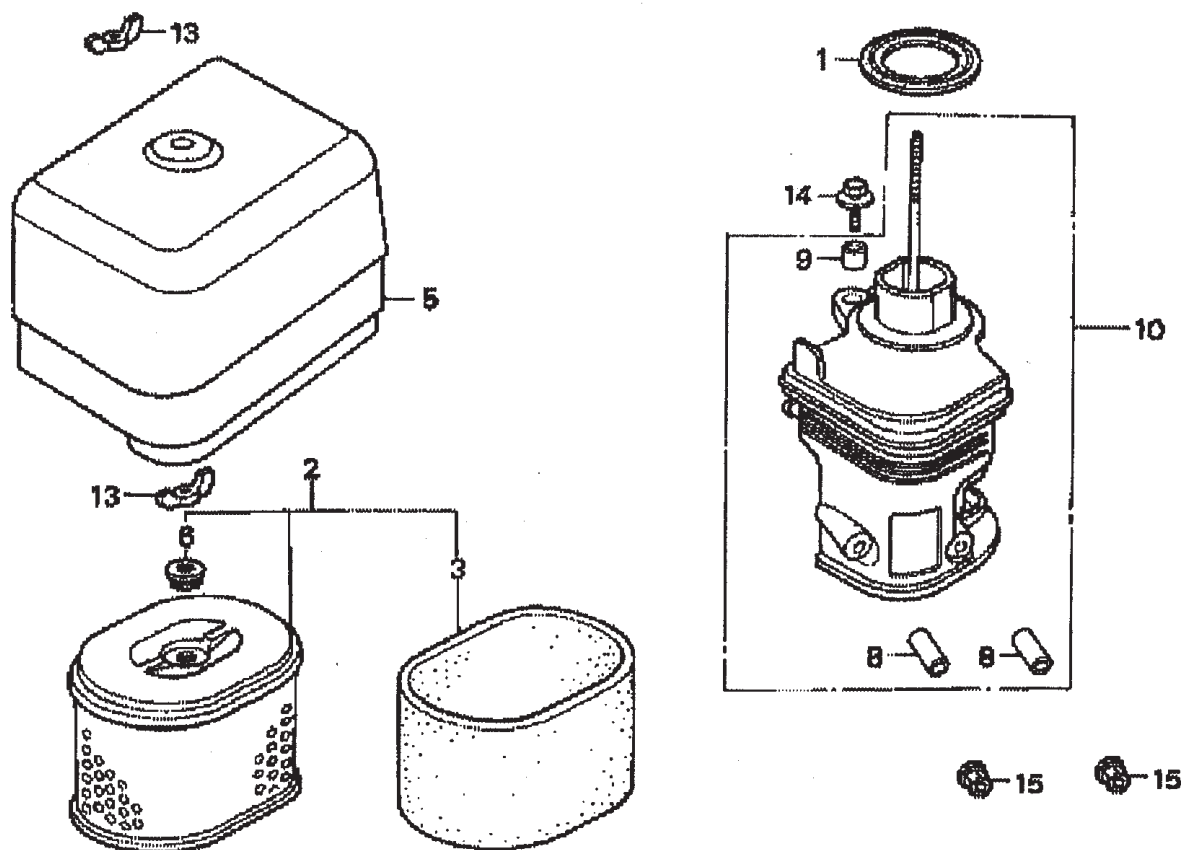

HONDA GX240K1QA2 ENGINE — AIR CLEANER ASSY.

AIR CLEANER ASSY.

<u>NO.</u>	<u>PART NO.</u>	<u>PART NAME</u>	<u>QTY.</u>	<u>REMARKS</u>
1	16271ZE2000	GASKET, ELBOW	1	
2	17210ZE2822	ELEMENT, AIR CLEANER, DUAL	1	INCLUDES ITEMS W/*
3*	17218ZE2505	FILTER, OUTER	1	
5	17231ZH9820	COVER, AIR CLEANER	1	
6	17232891000	GROMMET, AIR CLEANER	1	
8%	17238ZE2310	COLLAR, AIR CLEANER	2	
9%	17239ZE1000	COLLAR B, AIR CLEANER	1	
10	17410ZE2020	ELBOW COMP., AIR CLEANER	1	INCLUDES ITEMS W/%
13	90325044000	WINGNUT, TOOL BOX SETTING	2	
14	90009ZE2003	BOLT- WASHER 6 X 22	1	
15	9405006000	NUT, FLANGE 6MM	2	

HONDA GX240K1QA2 ENGINE — CAMSHAFT ASSY.

CAMSHAFT ASSY.

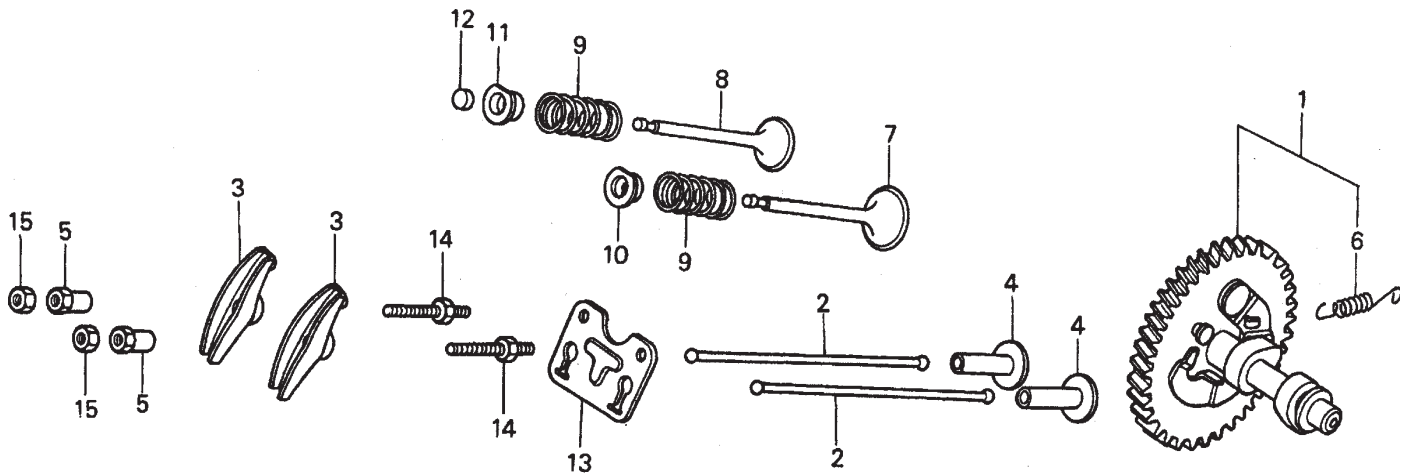

HONDA GX240K1QA2 ENGINE — CAMSHAFT ASSY.

CAMSHAFT ASSY.

<u>NO.</u>	<u>PART NO.</u>	<u>PART NAME</u>	<u>QTY.</u>	<u>REMARKS</u>
1	14100ZE2W01	CAMSHAFT ASSY.	1	INCLUDES ITEMS W/*
2	14410ZE2013	ROD PUSH	2	
3	14431ZE2010	ARM VALVE ROCKER	2	
4	14441ZE2000	LIFTER VALVE	2	
5	14451ZE1013	PIVOT ROCKER ARM	2	
6*	14568ZE1000	SPRING, WEIGHT RETURN	1	
7	14711ZE2000	VALVE, IN.	1	
8	14721ZE2000	VALVE, EX.	1	
9	14751ZE2003	SPRING, VALVE	2	
10	14771ZE2000	RETAINER, IN. VALVE SPRING	1	
11	14773ZE2000	RETAINER, EX. VALVE SPRING	1	
12	14781ZE2000	ROTATOR, VALVE	1	
13	14791ZE2010	PLATE, PUSH ROD GUIDE	1	
14	90012ZE0010	BOLT, PIVOT 8MM	2	
15	90206ZE1000	NUT, PIVOT ADJ.	2	

HONDA GX240K1QA2 ENGINE — CARBURETOR ASSY.

CARBURETOR ASSY.

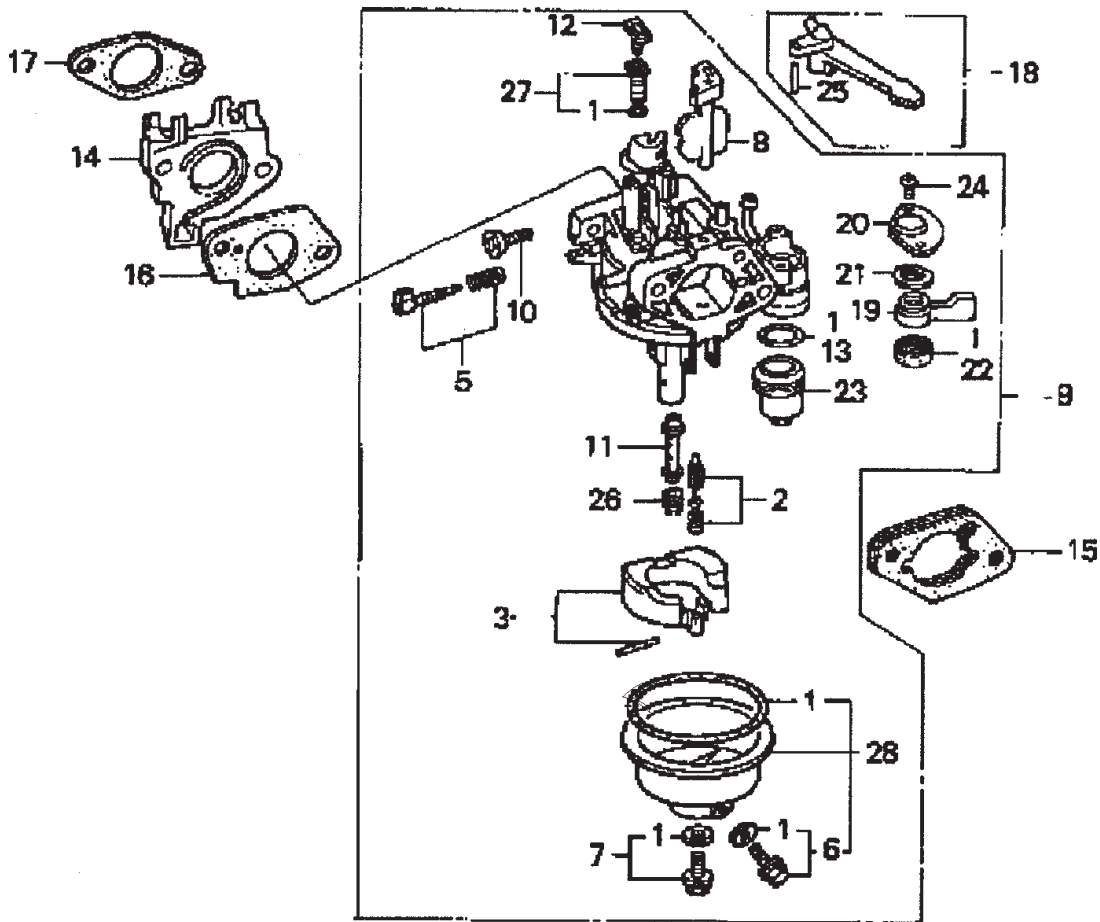

HONDA GX240K1QA2 ENGINE — CARBURETOR ASSY.

CARBURETOR ASSY.

<u>NO.</u>	<u>PART NO.</u>	<u>PART NAME</u>	<u>QTY.</u>	<u>REMARKS</u>
1*%+	16010ZE2812	GASKET SET	1	
2*	16011ZA0931	VALVE SET, FLOAT	1	
3*	16013ZA0931	FLOAT SET	1	
5*	16016ZHW01	SCREW SET	1	
6*+	16024ZE1811	SCREW SET, DRAIN	1	
7*	16028ZE0005	SCREW SET B	1	
8*	16028ZE2005	CHOKE SET	1	
9	16100ZE2W71	CARBURETOR ASSY.....	1	INCLUDES ITEMS W/*
10*	16124ZE0005	SCREW, THROTTLE STOP	1	
11*	16166ZE2W70	NOZZLE, MAIN	1	
12*	16172ZE3W10	COLLAR, SET	1	
13*	16173001004	O-RING	1	
14	16211ZE2000	INSULATOR, CARBURETOR	1	
15	16220ZA0702	SPACER COMP., CARBURETOR	1	
16	16221ZA0800	GASKET, CARBURETOR	1	
17	16223ZA0800	GASKET, INSULATOR	1	
18	16610ZE1000	LEVER COMP., CHOKE, STD.	1	INCLUDES ITEMS W/■
19*	16953ZE1812	LEVER, VALVE	1	
20*	16954ZE1811	PLATE, LEVER SETTING	1	
21*	16956ZE1811	SPRING, VALVE LEVER	1	
22*	16957ZE1812	GASKET, VALVE	1	
23*	16967ZE0811	CUP, FUEL STRAINER	1	
24	93500030060H	SCREW, PAN 3 X 6	2	
25■	9430520122	PIN, SPRING 2 X 12	1	
26	99101ZH80820	JET, MAIN #82, OPTIONAL	1	
26	99101ZH80850	JET, MAIN #85, OPTIONAL	1	
26*	99101ZH80880	JET, MAIN #88	1	
27*	99204ZE20400	JET SET, PILOT #40	1	INCLUDES ITEMS W/ %
28*	16015ZE8005	CHAMBER SET, FLOAT	1	INCLUDES ITEMS W/+

HONDA GX240K1QA2 ENGINE — CONTROL ASSY.

CONTROL ASSY.

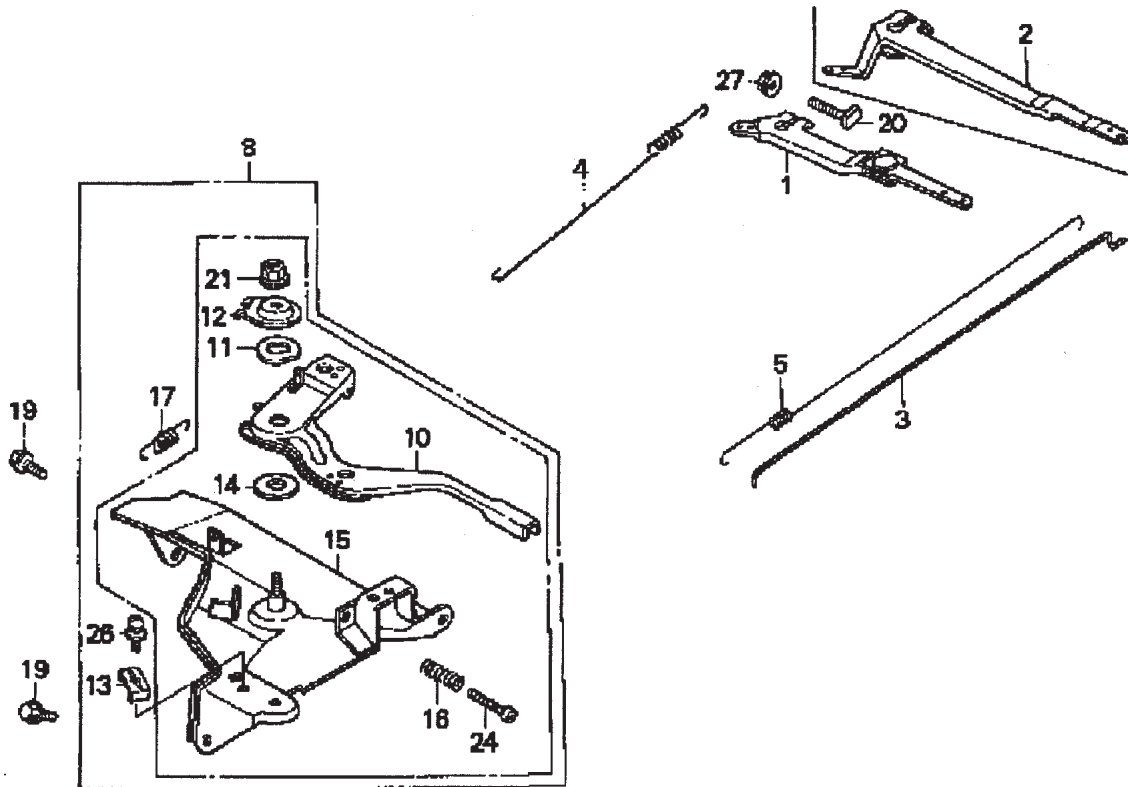

HONDA GX240K1QA2 ENGINE — CONTROL ASSY.

CONTROL ASSY.

<u>NO.</u>	<u>PART NO.</u>	<u>PART NAME</u>	<u>QTY.</u>	<u>REMARKS</u>
1	16550ZE2700	ARM, GOVERNOR	1	
2	16551ZE2000	ARM, GOVERNOR	1	
3	16555ZE2000	ROD, GOVERNOR	1	
4	16561ZE2000	SPRING, GOVERNOR	1	
5	16562ZE2000	SPRING, THROTTLE RETURN	1	
8	16570ZE2W20	CONTROL ASSY., REMOTE	1	INCLUDES ITEMS W/*
10*	16571ZE2W00	LEVER, CONTROL	1	
11*	16574ZE1000	SPRING, LEVER	1	
12*	16575ZE2W00	WASHER, CONTROL LEVER	1	
13*	16576891000	HOLDER, CABLE	1	
14*	16578ZE1000	SPACER, CONTROL LEVER	1	
15*	16581ZE2W00	BASE COMP., CONTROL	1	
16*	16584883300	SPRING, CONTROL ADJUSTING	1	
17*	16592883310	SPRING, CABLE RETURN	1	
19	90013883000	BOLT, FLANGE 6 X 12 CT200	2	
20	90015ZE5010	BOLT, GOVERNOR ARM	1	
21	90114SA0000	NUT, SELF-LOCK 6MM	1	
24*	93500050280A	SCREW, PAN 5 X 28	1	
26*	93500050160A	SCREW, PAN 5 X 16	1	
27	9405006000	NUT, FLANGE 6MM	1	

HONDA GX240K1QA2 ENGINE — CRANKCASE COVER ASSY.

CRANKCASE COVER ASSY.

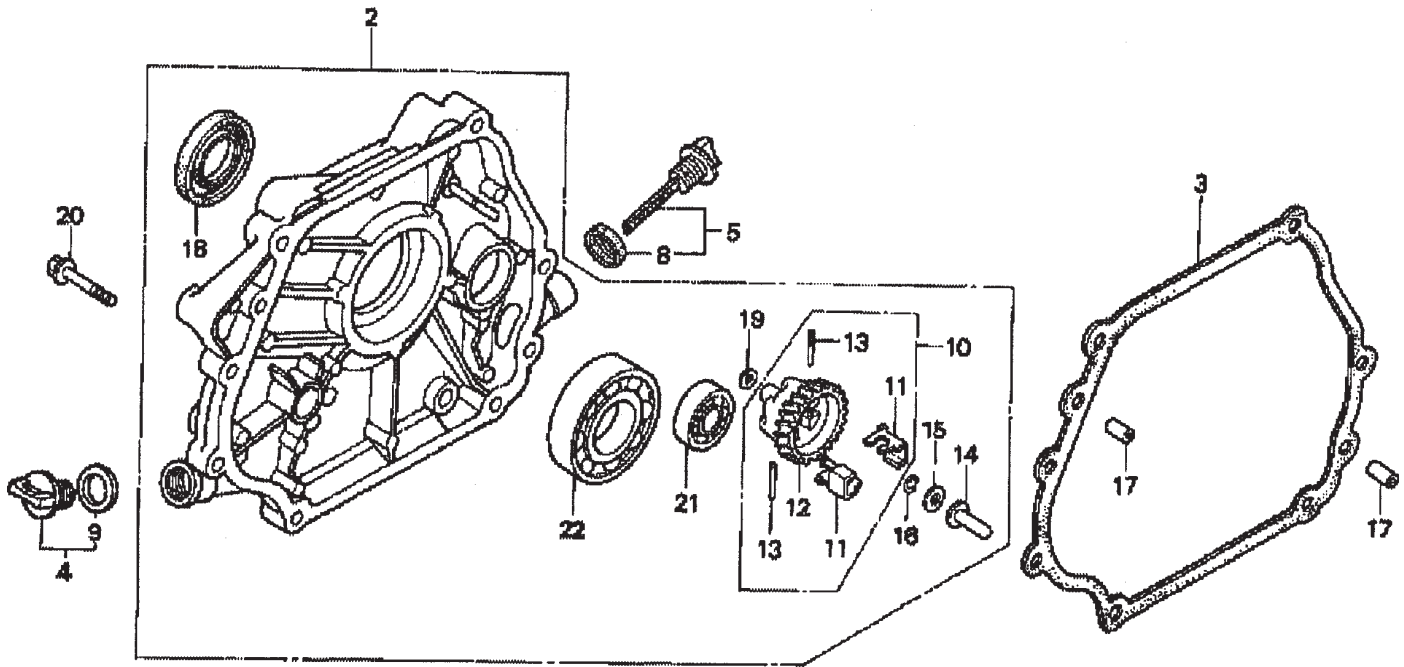

HONDA GX240K1QA2 ENGINE — CRANKCASE COVER ASSY.

CRANKCASE COVER ASSY.

<u>NO.</u>	<u>PART NO.</u>	<u>PART NAME</u>	<u>QTY.</u>	<u>REMARKS</u>
2	11400ZE2601	COVER ASSY., CRANKCASE	1	INCLUDES ITEMS W/*
3	11381ZE2801	GASKET, CASE COVER	1	
4	15600ZG4003	CAP ASSY., OIL FILLER	1	INCLUDES ITEMS W/%
5	15600735003	CAP ASSY., OIL FILLER	1	INCLUDES ITEMS W/+
8+	15625ZE1000	GASKET, OIL FILLER CAP	1	
9%	15625ZE1003	GASKET, OIL FILLER CAP	1	
10*	16510ZE2811	GOVERNOR ASSY., BALANCER	1	INCLUDES ITEMS W/\$
11*\$	16511ZE2000	WEIGHT, GOVERNOR	2	
12*\$	16512ZE2811	HOLDER, GOVERNOR WEIGHT	1	
13*\$	16513ZE2000	PIN, GOVERNOR WEIGHT	2	
14*	16531ZE2000	SLIDER, GOVERNOR	1	
15*	90473147000	WASHER 6 X 16	1	
16*	90602ZE1000	CLIP, GOVERNOR HOLDER	1	
17	90701HC4000	PIN, DOWEL 8 X 12	2	
18*	91201890003	OIL SEAL 30 X 46 X 8	1	
19*	9410106800	WASHER, PLAIN 6MM	1	
20	957010803500	BOLT, FLANGE 8 X 35	7	
21*	961006202000	BEARING, RADIAL BALL 6202	1	
22*	961006206000	BEARING, RADIAL BALL 6206		

HONDA GX240K1QA2 ENGINE — CRANKSHAFT ASSY.

CRANKSHAFT ASSY.

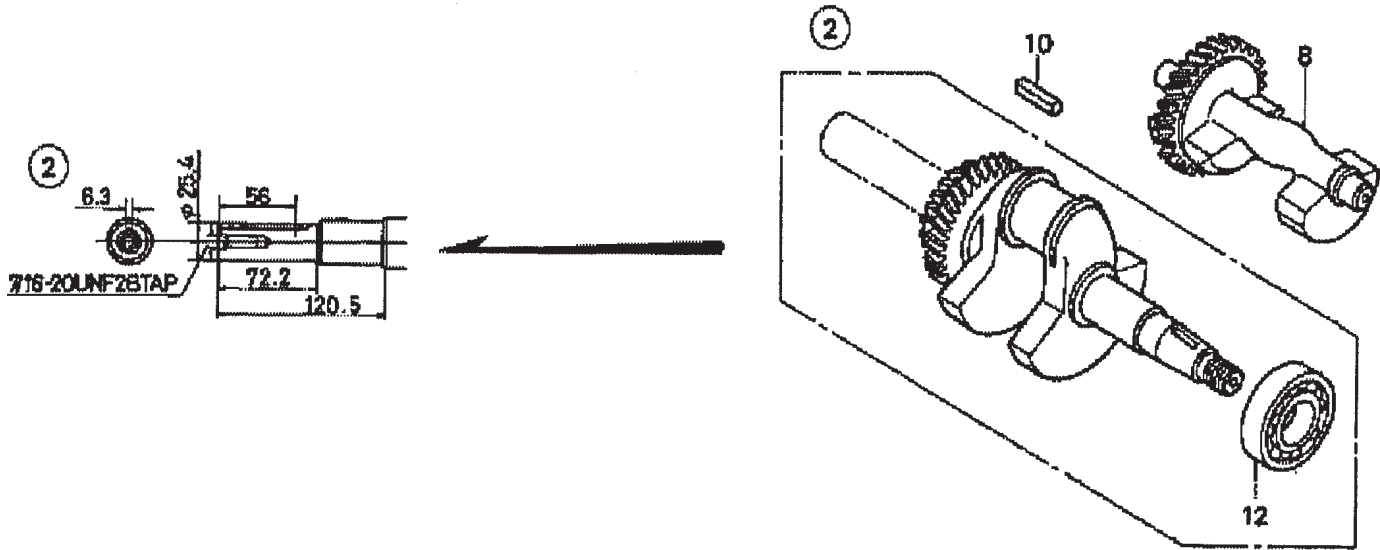

HONDA GX240K1QA2 ENGINE — CRANKSHAFT ASSY.

CRANKSHAFT ASSY.

<u>NO.</u>	<u>PART NO.</u>	<u>PART NAME</u>	<u>QTY.</u>	<u>REMARKS</u>
2	13320ZE2601	CRANKSHAFT COMP., Q- TYPE	1	INCLUDES ITEMS W/*
8	13351ZE2010	WEIGHT, BALANCER	1	
10	90745ZE2600	KEY 6.3 X 6.3 X 43	1	
12*	961006206000	BEARING, RADIAL BALL 6206	1	

HONDA GX240K1QA2 ENGINE — CYLINDER BARREL ASSY.

CYLINDER BARREL ASSY.

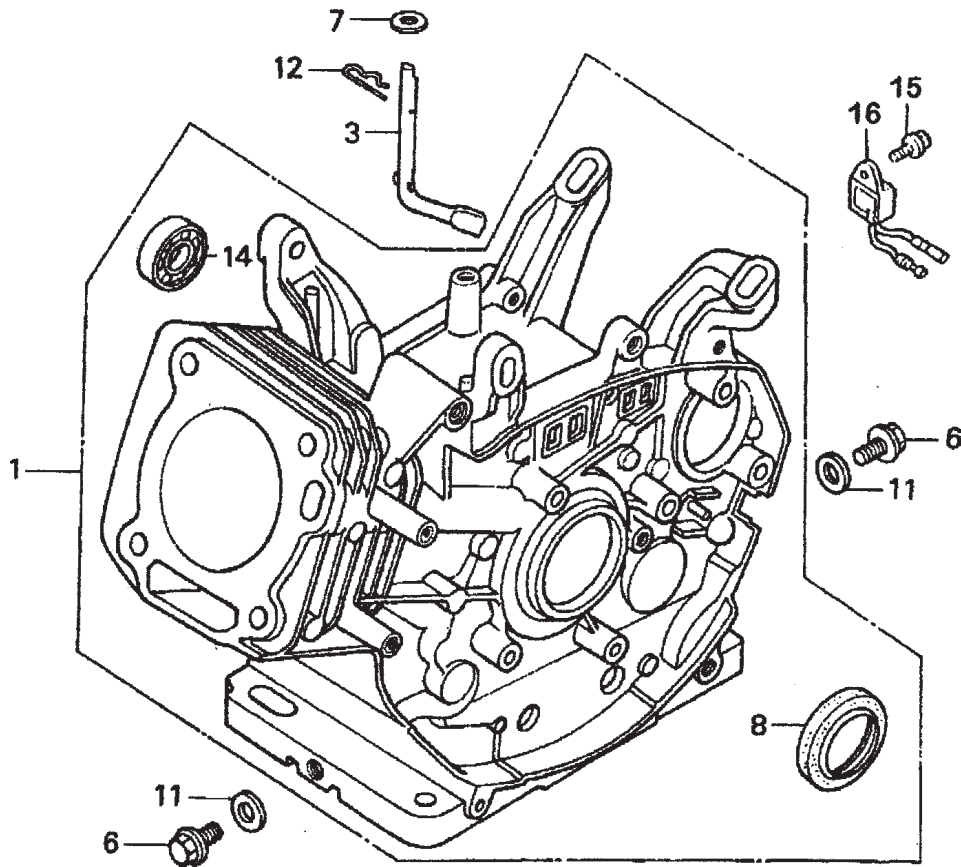

HONDA GX240K1QA2 ENGINE — CYLINDER BARREL ASSY.

CYLINDER BARREL ASSY.

<u>NO.</u>	<u>PART NO.</u>	<u>PART NAME</u>	<u>QTY.</u>	<u>REMARKS</u>
1	12000ZE2834	CYLINDER ASSY., BALANCER + OIL ALERT	1	INCLUDES ITEMS W/*
3	16541ZE2010	SHAFT, GOVERNOR ARM	1	
6	90131896650	BOLT, DRAIN PLUG	2	
7	90446KE1000	WASHER 8.2 X17X0.8	1	
8*	91201890003	OIL SEAL 30X46X8	1	
11	9410912000	WASHER, DRAIN PLUG 12MM	2	
12	9425110000	PIN, LOCK 10MM	1	
14*	961006202000	BEARING, RADIAL BALL 6202	1	
15	90013883000	BOLT, FLANGE 6X12 CT200	1	
16	34150ZH7003	ALERT UNIT, OIL	1	

HONDA GX240K1QA2 ENGINE — CYLINDER HEAD ASSY.

CYLINDER HEAD ASSY.

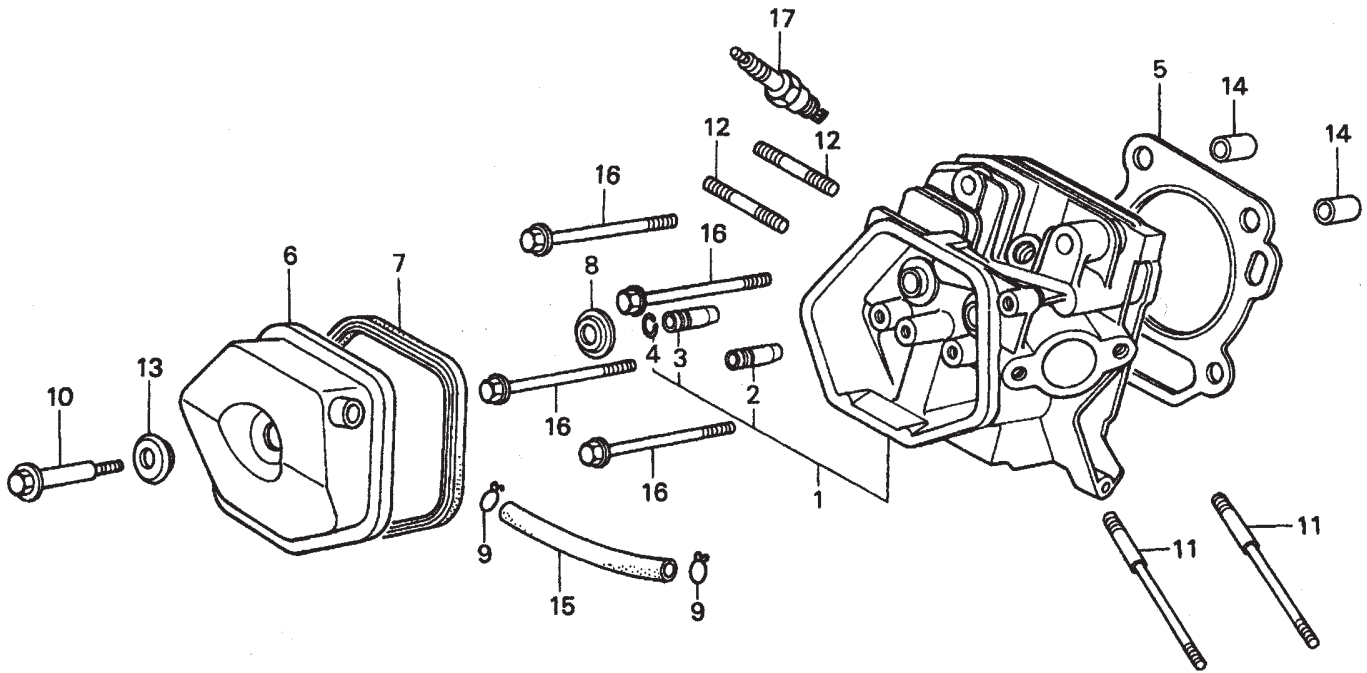

HONDA GX240K1QA2 ENGINE — CYLINDER HEAD ASSY.

CYLINDER HEAD ASSY.

<u>NO.</u>	<u>PART NO.</u>	<u>PART NAME</u>	<u>QTY.</u>	<u>REMARKS</u>
1	12200ZH9000	CYLINDER HEAD COMP.	1	INCLUDES ITEMS W/*
2*	12204ZE2306	GUIDE, VALVE, OS, OPTIONAL	1	
3*	12205ZE2305	GUIDE, EX. VALVE, OS, OPTIONAL	1	
4*	12216ZE2300	CLIP, VALVE GUIDE	1	
5	12251ZE2800	GASKET, CYLINDER HEAD	1	
6	12310ZE2020	COVER COMP., HEAD	1	
7	12391ZE2020	GASKET, CYLINDER HEAD COVER	1	
8	14775ZE2010	SEAT, VALVE SPRING	1	
10	90014ZE2000	BOLT, HEAD COVER	1	
11	90042ZE2000	BOLT, STUD 8X123	2	
12	92900080320E	BOLT 2, STUD 8X32	2	
13	90441ZE2010	WASHER COMP., HEAD COVER	1	
14	9430112200	PIN A, DOWEL 12X20	2	
15	950051100130M	BULK HOSE, VACUUM 11X1000, 11X100	1	
16	957011008000	BOLT, FLANGE 10X80	4	
17	9807955846	SPARK PLUG, BPR5ES, NGK	1	
17	9807955855	SPARK PLUG, W16EPR-U, DENSO, OPTIONAL	1	
17	9807956846	SPARK PLUG, BPR6ES, NGK	1	
17	9807956855	SPARK PLUG, W20EPR-U, DENSO	1	

HONDA GX240K1QA2ENGINE — FAN COVER ASSY.

FAN COVER ASSY.

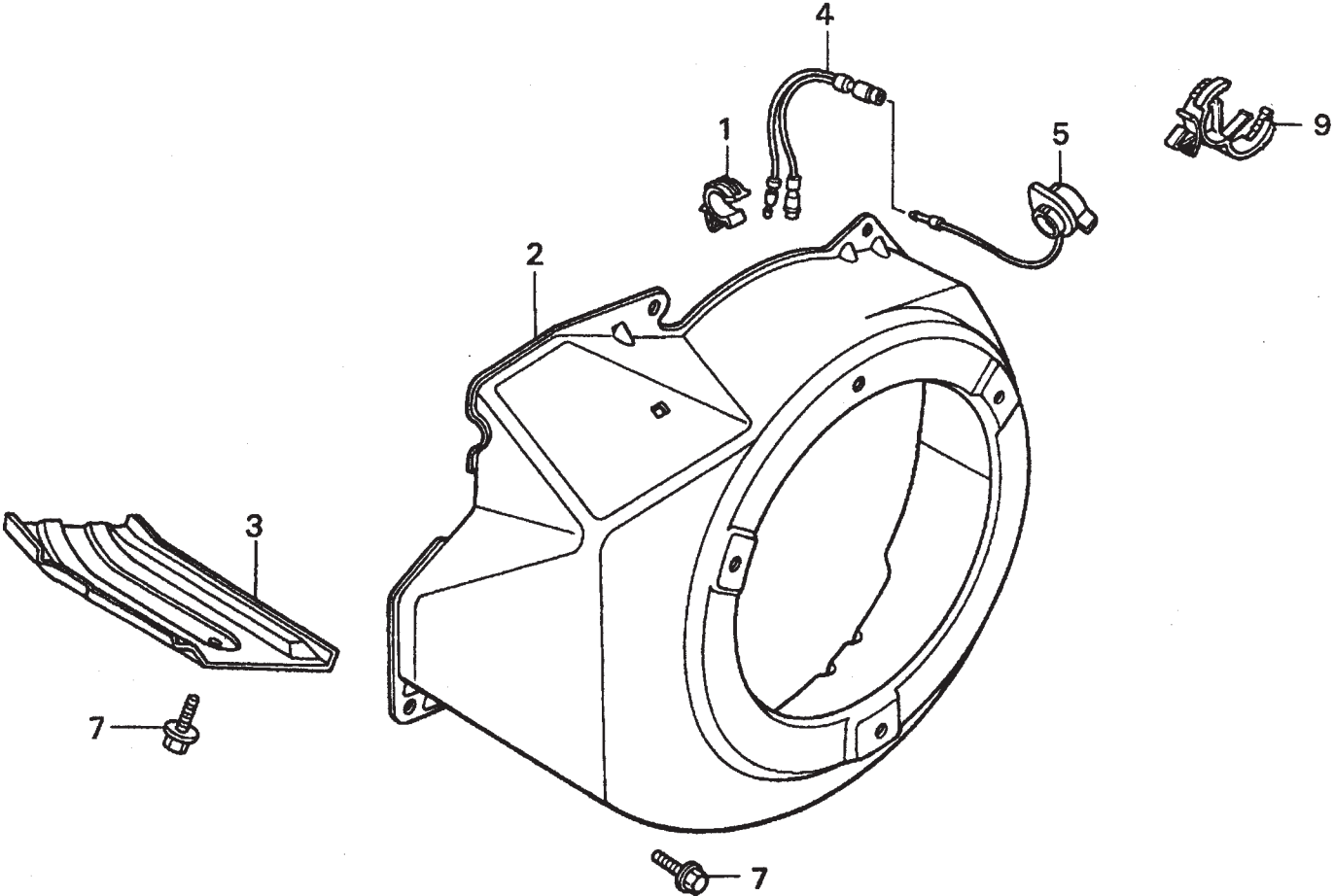

HONDA GX240K1QA2ENGINE — FAN COVER ASSY.

FAN COVER ASSY.

<u>NO.</u>	<u>PART NO.</u>	<u>PART NAME</u>	<u>QTY.</u>	<u>REMARKS</u>
1	16731ZE2003	CLIP, TUBE	1	
2	19610ZE2010ZC	COVER COMP., FAN *NH1* BLACK	1	
3	19631ZE2D00	SHROUD	1	
4	32197ZH8003	SUB-HARNESS	1	
5	36100ZH7003	SWITCH ASSY., ENGINE STOP	1	
7	90013883000	BOLT, FLANGE 6X12, CT200	6	
9	90684ZA0601	CLIP, WIRE HARNESS	1	

HONDA GX240K1QA2 ENGINE — FLYWHEEL ASSY.

FLYWHEEL ASSY.

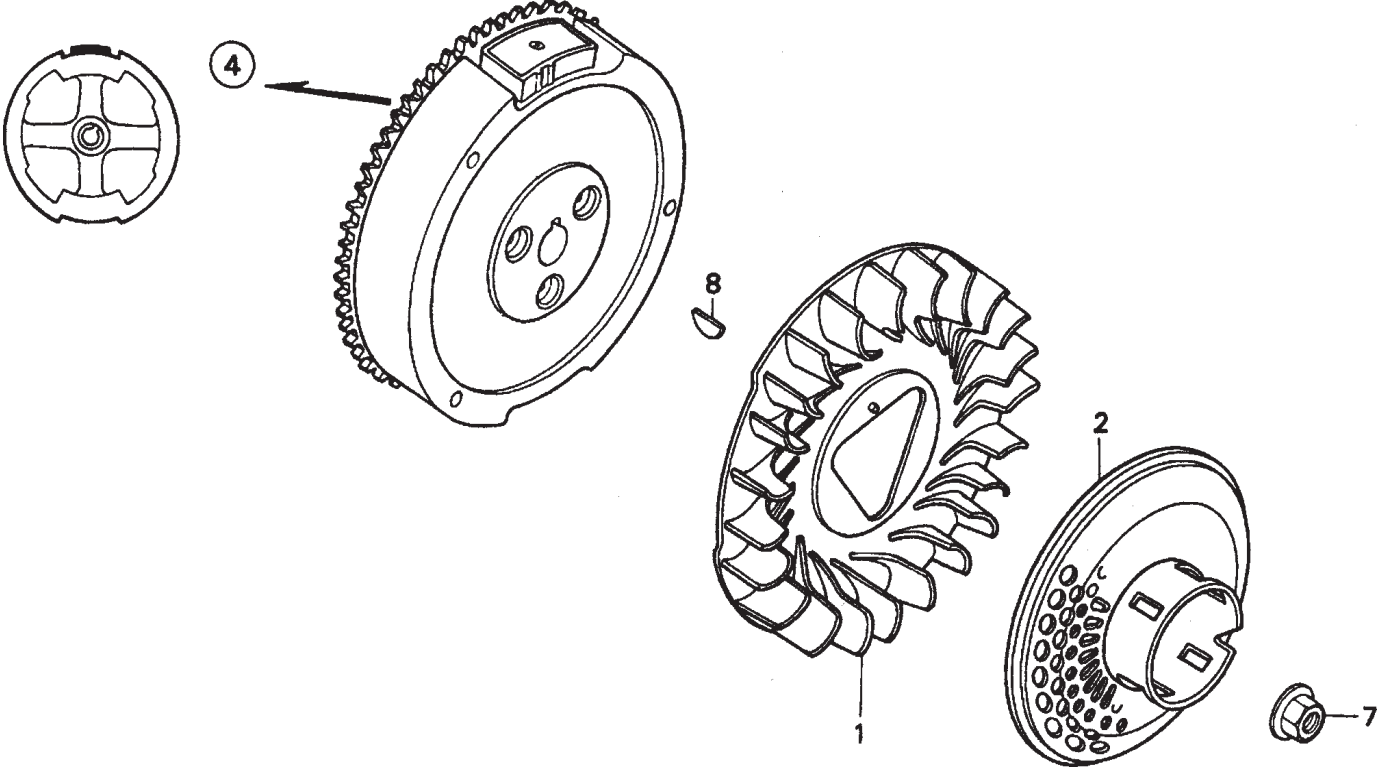

HONDA GX240K1QA2 ENGINE — FLYWHEEL ASSY.

FLYWHEEL ASSY.

<u>NO.</u>	<u>PART NO.</u>	<u>PART NAME</u>	<u>QTY.</u>	<u>REMARKS</u>
1	19511ZE2000	FAN, COOLING	1	
2	28450ZE2W11	PULLEY COMP., STARTER, SCREEN GRID	1	
4	31100ZE2010	FLYWHEEL COMP.	1	
7	90201ZE3V00	NUT, SPECIAL 16MM	1	
8	90741ZE2000	KEY, SPECIAL WOODRUFF 25X18	1	

HONDA GX240K1QA2ENGINE — FUEL TANK ASSY.

FUEL TANK ASSY.

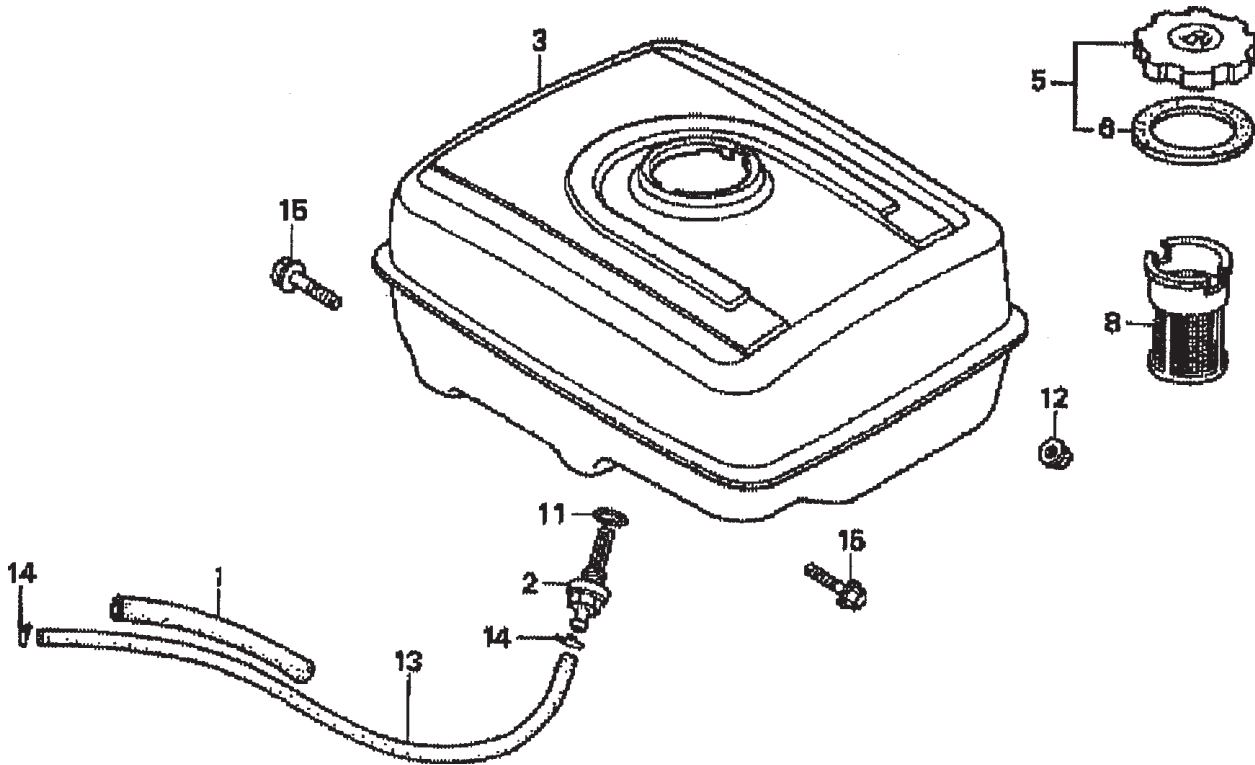

HONDA GX240K1QA2ENGINE — FUEL TANK ASSY.

FUEL TANK ASSY.

<u>NO.</u>	<u>PART NO.</u>	<u>PART NAME</u>	<u>QTY.</u>	<u>REMARKS</u>
1	16854ZH8000	RUBBER SUPPORTER 107MM	1	
2	16955ZE1000	JOINT, FUEL TANK	1	
3	17510ZE2020ZD	TANK COMP., FUEL *NH1*, BLACK	1	
5	17620ZH7023	CAP COMP., FUEL FILLER	1	INCLUDES ITEMS W/*
6*	17631ZH7003	GASKET, FUEL FILLER CAP	1	
8	17672ZE2W01	FILTER, FUEL	1	
11	91353671003	O-RING 14MM, ARAI	1	
12	9405008000	NUT, FLANGE 8MM	2	
13	950014500360M	BULK HOSE, FUEL 4.5X3000, 4.5X222	1	
14	9500202080	CLIP, TUBE, B8	2	
15	957010802500	BOLT, FLANGE 8X25	2	

HONDA GX240K1QA2 ENGINE — IGNITION COIL ASSY.

IGNITION COIL ASSY.

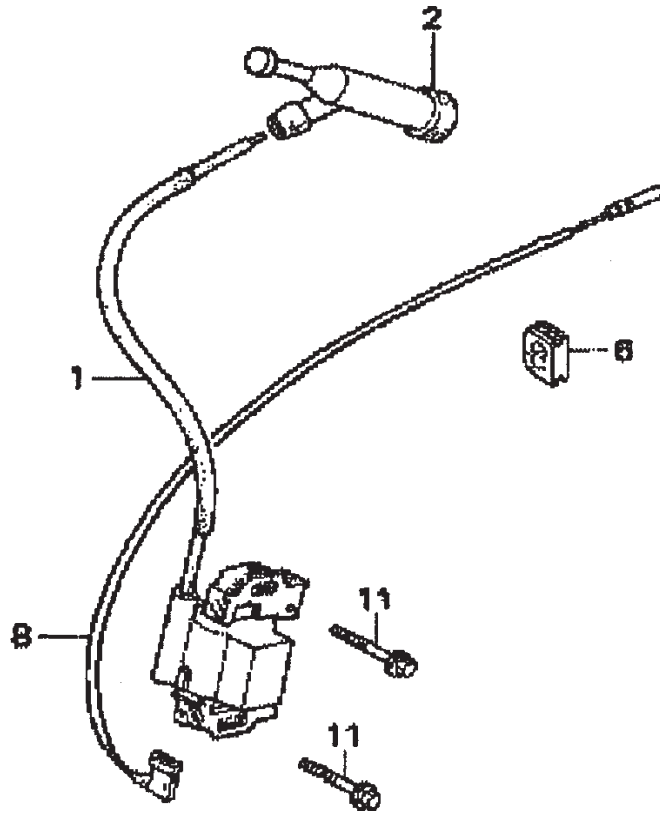

HONDA GX240K1QA2 ENGINE — IGNITION COIL ASSY.

IGNITION COIL ASSY.

<u>NO.</u>	<u>PART NO.</u>	<u>PART NAME</u>	<u>QTY.</u>	<u>REMARKS</u>
1	30500ZE2023	COIL ASSY., IGNITION	1	
2	30700ZE1013	CAP ASSY., NOISE SUPPRESSOR	1	
6	31512ZE2000	GROMMET, WIRE	1	
8	36101ZE1010	WIRE, STOP SWITCH 370MM	1	
11	90015883000	BOLT, FLANGE 6X28	2	

HONDA GX240K1QA2 ENGINE — MUFFLER ASSY.

MUFFLER ASSY.

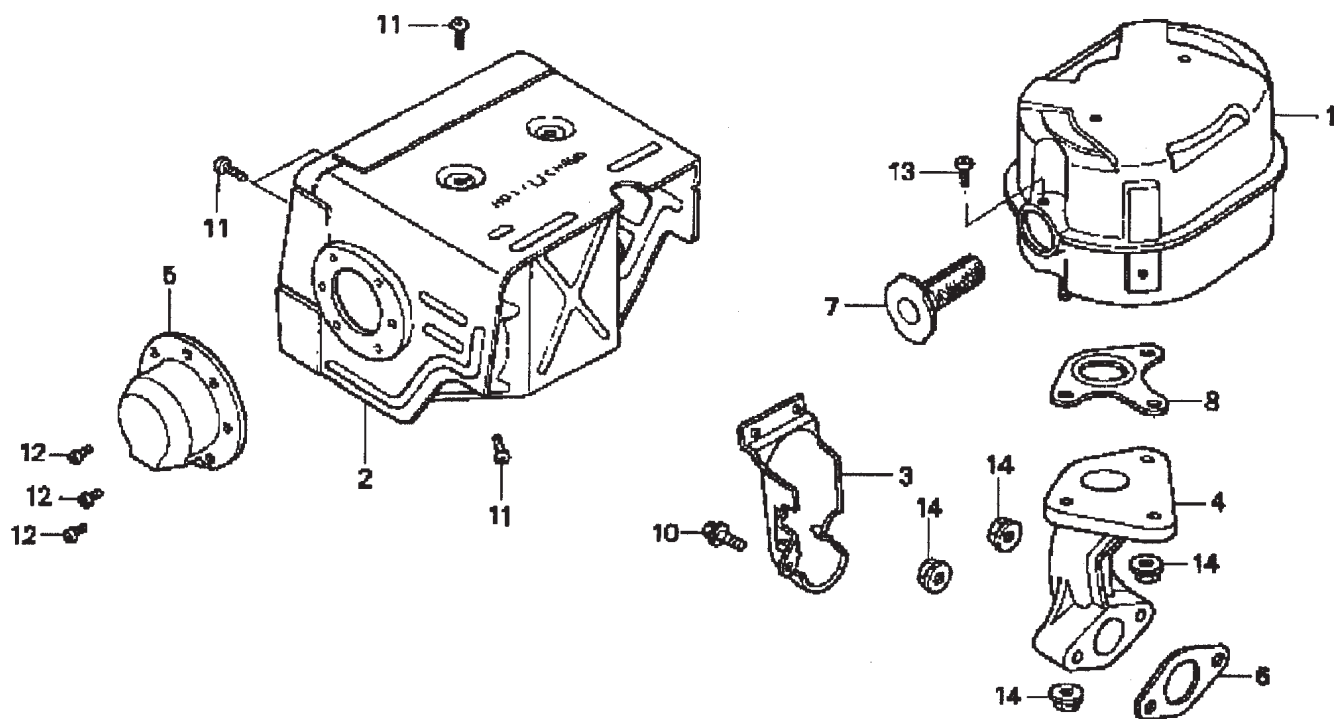

HONDA GX240K1QA2 ENGINE — MUFFLER ASSY.

MUFFLER ASSY.

<u>NO.</u>	<u>PART NO.</u>	<u>PART NAME</u>	<u>QTY.</u>	<u>REMARKS</u>
1	18310ZE2W00	MUFFLER COMP.	1	
2	18320ZE2W01	PROTECTOR COMP., MUFFLER	1	
3	18323ZE2W00	PROTECTOR, EX. PIPE	1	
4	18330ZE2W00	PIPE, EX.	1	
5	18331ZE2810	CAP, MUFFLER	1	
6	18333ZE3800	GASKET, EX. PIPE	1	
7	18355ZE2010	ARRESTER, SPARK	1	
8	18381ZE2W10	GASKET, MUFFLER, ARRESTER	1	
10	90013883000	BOLT, FLANGE 6X12 CT200	1	
11	90050ZE1000	SCREW, TAPPING 5X8	6	
12	90055ZE1000	SCREW, TAPPING 4X6	3	
13	90050ZE1000	SCREW, TAPPING 5X8	1	
14	9405008000	NUT, FLANGE 8MM	5	

HONDA GX240K1QA2 ENGINE — PISTON ASSY.

PISTON ASSY.

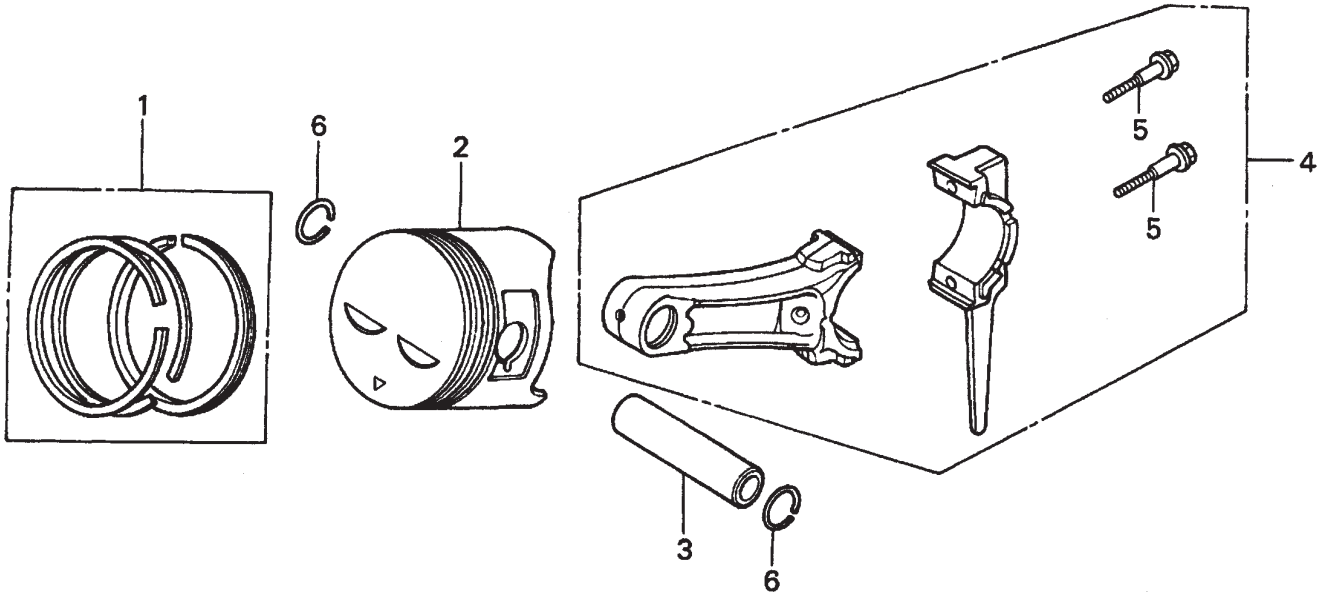

HONDA GX240K1QA2 ENGINE — PISTON ASSY.

PISTON ASSY.

<u>NO.</u>	<u>PART NO.</u>	<u>PART NAME</u>	<u>QTY.</u>	<u>REMARKS</u>
1	13010ZE2013	RING SET, PISTON, STD.	1	
1	13011ZE2013	RING SET, PISTON, OS 0.25, OPTIONAL	1	
1	13012ZE2013	RING SET, PISTON, OS 0.50, OPTIONAL	1	
1	13013ZE2013	RING SET, PISTON, 0.75, OPTIONAL	1	
2	13101ZE2W00	PISTON, STANDARD	1	
2	13102ZE2W00	PISTON, OS 0.25, OPTIONAL	1	
2	13103ZE2W00	PISTON, OS 0.50, OPTIONAL	1	
2	13104ZE2W00	PISTON, 0.75, OPTIONAL	1	
3	13111ZE2000	PIN, PISTON	1	
4	13200ZE2000	ROD ASSY., CONNECTING STANDARD	1	INCLUDES ITEMS W/*
4	13200ZE2305	ROD ASSY., CONNECTING, US 0.25, OPT.	1	INCLUDES ITEMS W/*
5*	90001ZE8000	BOLT, CONNECTING ROD	2	
6	90551ZE1000	CLIP, PISTON PIN 18MM	2	

HONDA GX240K1QA2 ENGINE — RECOIL STARTER ASSY.

RECOIL STARTER ASSY.

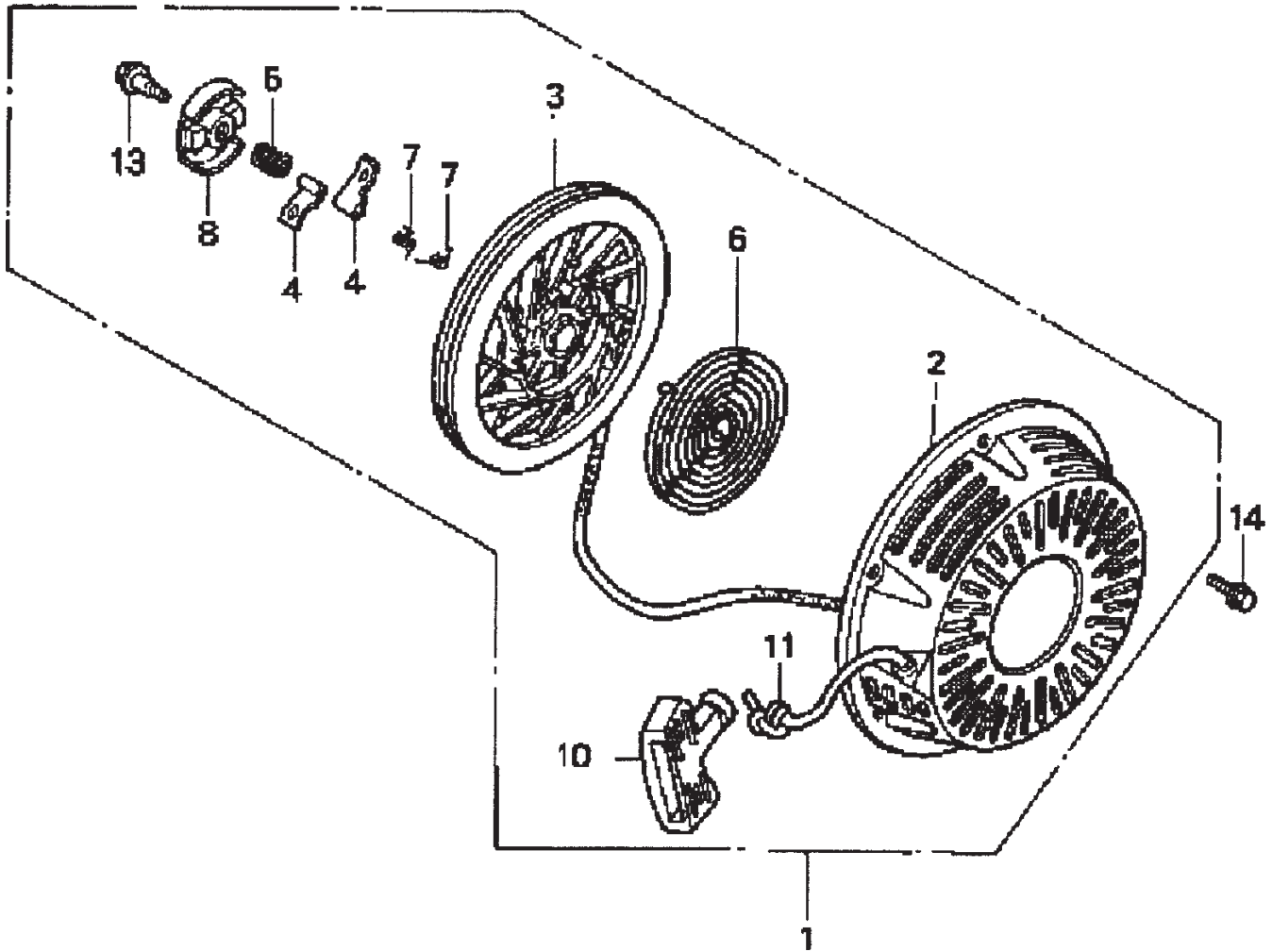

HONDA GX240K1QA2 ENGINE — RECOIL STARTER ASSY.

RECOIL STARTER ASSY.

<u>NO.</u>	<u>PART NO.</u>	<u>PART NAME</u>	<u>QTY.</u>	<u>REMARKS</u>
1	28400ZE2W01ZB	STARTER ASSY., RECOIL *NH1*, BLACK	1	INCLUDES ITEMS W/*
2*	28410ZE2W01ZB	CASE COMP., RECOIL STARTER *NH1*, BLACK	1	
3*	28421ZE2W01	PULLEY, RECOIL STARTER	1	
4*	28422ZE2W01	RATCHET, STARTER	2	
5*	28441ZE2W01	SPRING, FRICTION	1	
6*	28442ZE2W01	SPRING, STARTER RETURN	1	
7*	28443ZE2W01	SPRING RATCHET	2	
8*	28444ZE2W01	RETAINER, SPRING	1	
10*	28461ZE2W02	GRIP, STARTER	1	
11*	28462ZE2W11	ROPE, RECOIL STARTER	1	
13*	90004ZE2W01	SCREW, CENTER	1	
14	90008ZE2003	BOLT, FLANGE 6X10	3	

HONDA GX240K1QA2 ENGINE — LABELS

LABELS

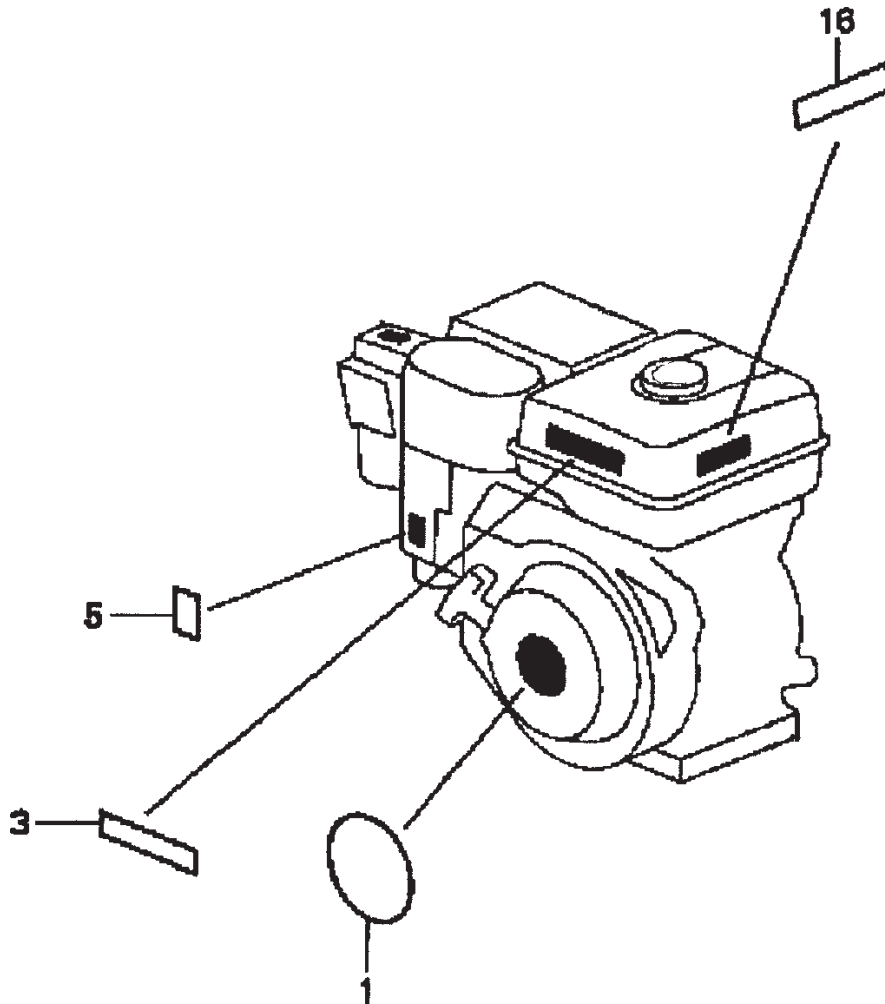

HONDA GX240K1QA2 ENGINE — LABELS

LABELS

<u>NO.</u>	<u>PART NO.</u>	<u>PART NAME</u>	<u>QTY.</u>	<u>REMARKS</u>
1	87521ZE2W01	EMBLEM, INTERNAL	1	
3	87522ZH9000	LABEL, CAUTION	1	
5	87528ZE2810	MARK, CHOKE, EXTERNAL	1	
16	87532ZH8810	MARK, OIL ALERT, E	1	

ROBIN EH25-2 ENGINE — CRANKCASE ASSY.

CRANKCASE ASSY.

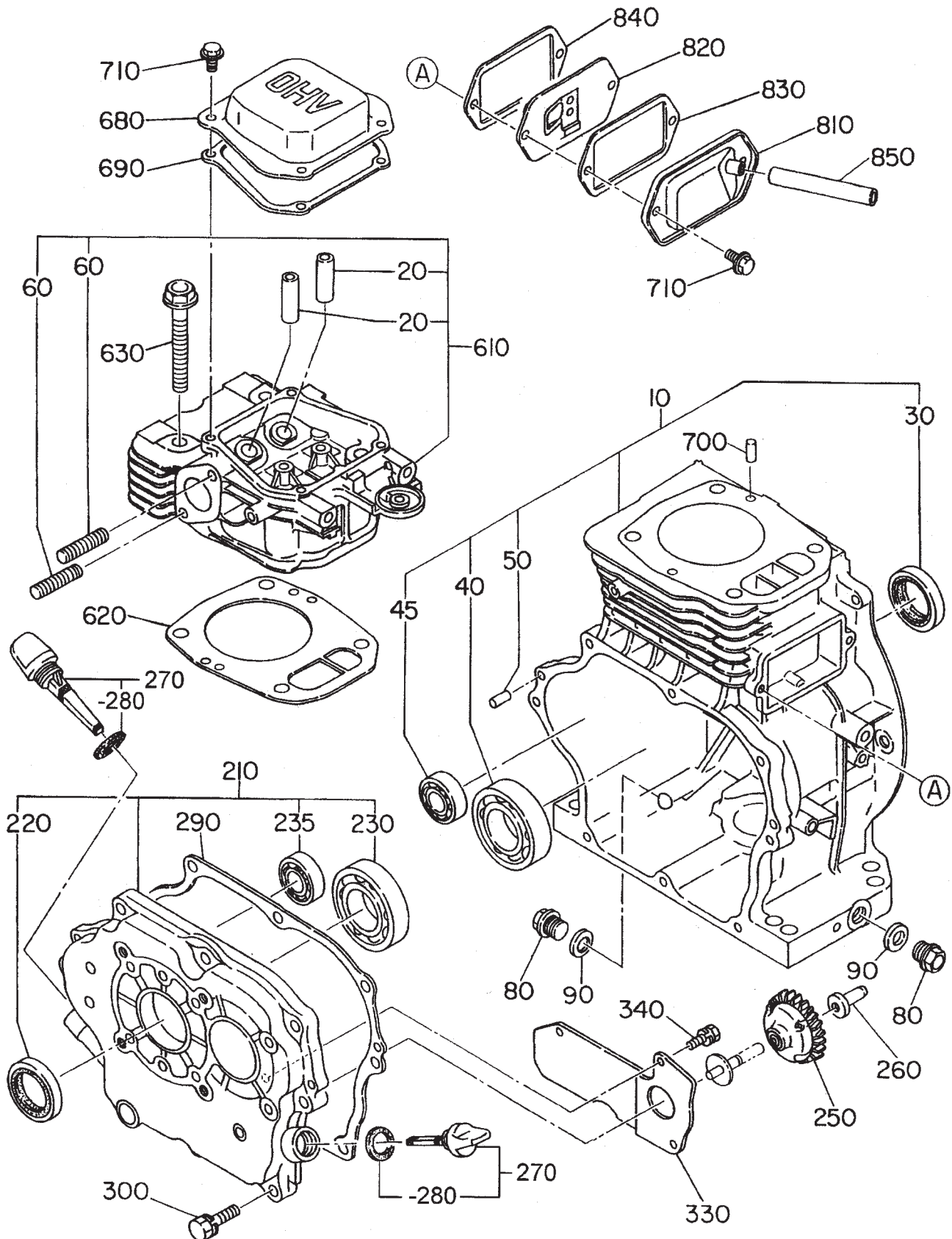

ROBIN EH25-2 ENGINE — CRANKCASE ASSY.

CRANKCASE ASSY.

<u>NO.</u>	<u>PART NO.</u>	<u>PART NAME</u>	<u>QTY.</u>	<u>REMARKS</u>
10	2541010131	CRANKCASE CP	1	INCLUDES ITEMS W/*
20#	13212AA080	VALVE GUIDE	2	
30*	0440300030	OIL SEAL	1	
40*	0600300020	BALL BEARING (6206C3)	1	
45*	0600150010	BALL BEARING (6202C3)	1	
50*	0310060020	DOWEL PIN	2	
60#	0105080290	STUD	2	
80	0401140030	PLUG	2	
90	0211140020	GASKET	2	
210	2541100301	MAIN BEARING COVER CP	1	INCLUDES ITEMS W/+
220+	0440300030	OIL SEAL	1	
230+	0600300020	BALL BEARING (6206C3)	1	
235+	0600150010	BALL BEARING (6202C3)	1	
250	2344500101	GOVERNOR GEAR CP	1	
260	2054190103	GOVERNOR SLEEVE	1	
270	2276360107	OIL GAUGE ASSY.	1	INCLUDES ITEMS W/%
	2276360107	OIL GAUGE ASSY. (W/OIL SENSOR)	1	INCLUDES ITEMS W/%
280%	0213160020	GASKET	2	
290	2541600103	GASKET, BEARING COVER	1	
300	0011308300	BOLT AND WASHER ASSY.	8	
330	2541750213	OIL SHELTER (SENSOR)	1	W/OIL SENSOR
340	0043505100	SCREW AND WASHER ASSY.	3	W/OIL SENSOR
610	2701300101	CYLINDER HEAD CP	1	INCLUDES ITEMS W/#
620	2541500113	GASKET, HEAD	1	
630	0110100040	FLANGE BOLT	4	
680	2701550303	ROCKER COVER	1	
690	2701600403	GASKET, ROCKER COVER	1	
700	0310060020	DOWEL PIN	2	
710	0110060020	FLANGE BOLT	6	
810	2541430101	BREATHER COVER CP	1	
820	2541440111	BREATHER PLATE CP	1	
830	2461600603	GASKET, BREATHER COVER	1	
840	2461600713	GASKET, BREATHER PLATE	1	
850	0851080000	RUBBER PIPE	1	8 X11 X 60
	0851080000	RUBBER PIPE	1	CYCLONE TYPE 8 X 11 X 75
960	2549900107	GASKET SET	1	

ROBIN EH25-2 ENGINE — CRANKSHAFT ASSY.

CRANKSHAFT ASSY.

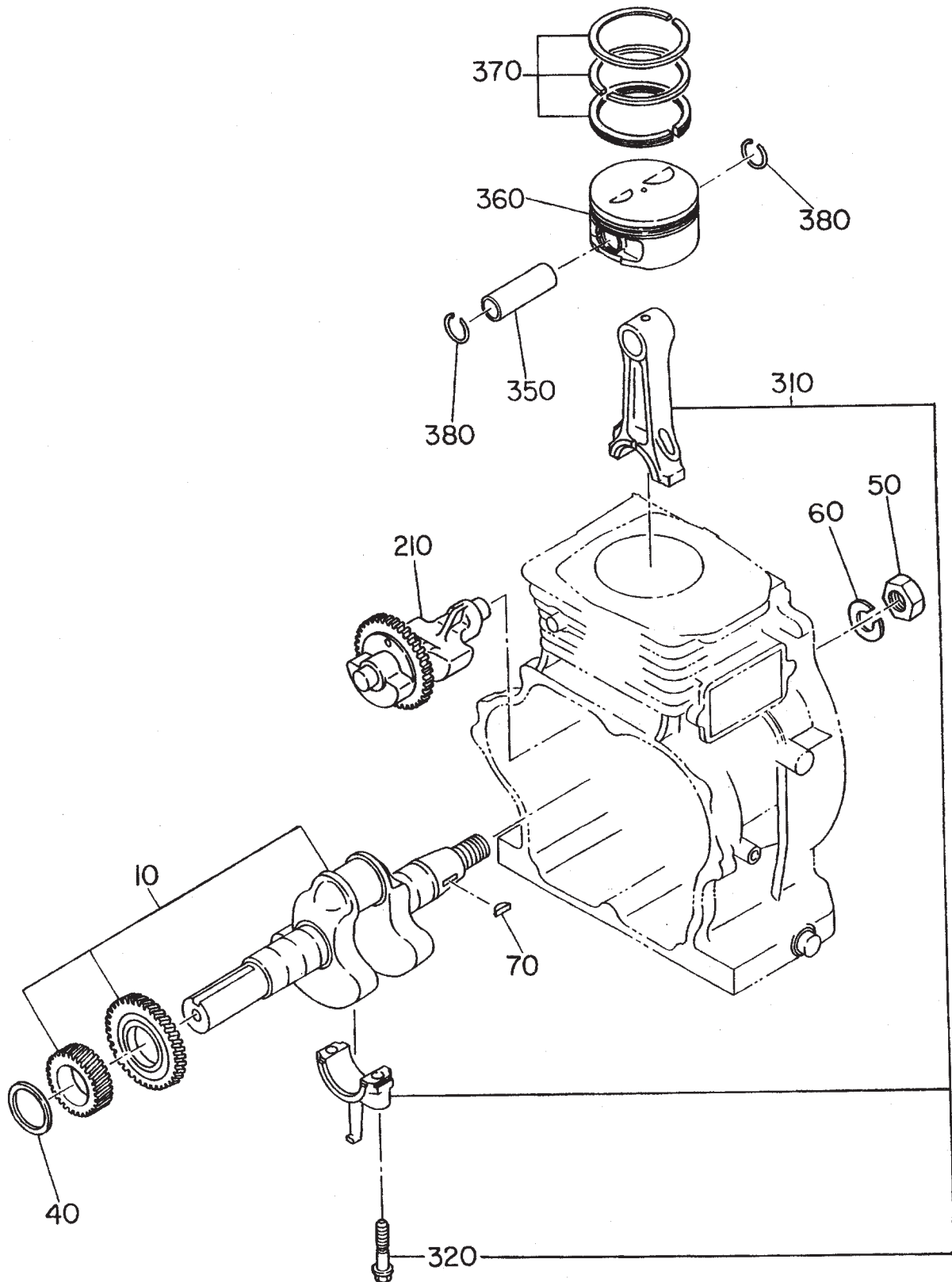

ROBIN EH25-2 ENGINE — CRANKSHAFT ASSY.

CRANKSHAFT ASSY.

<u>NO.</u>	<u>PART NO.</u>	<u>PART NAME</u>	<u>QTY.</u>	<u>REMARKS</u>
10	2542090101	CRANKSHAFT CP	1	SAE 1" KEYED SHAFT
40	0230300170	SPACER T=0.6	1	SELECT 1 SPACER ONLY
	0230300180	SPACER T=0.8	1	SELECT 1 SPACER ONLY
	0230300190	SPACER T=1.0	1	SELECT 1 SPACER ONLY
50	0021808000	NUT	1	
60	0032018000	SPRING WASHER	1	
70	0323030010	WOODRUFF KEY	1	
210	2542410103	BALANCER SHAFT	1	
310	2542250100	CONNECTING ROD ASSY.	1	INCLUDES ITEMS W/*
320*	2462300103	CONNECTING ROD BOLT	2	
350	2702330103	PISTON PIN	1	
360	2702340103	PISTON	1	STANDARD
	2702340203	PISTON	1	OVERSIZE 0.25 MM
	2702340303	PISTON	1	OVERSIZE 0.50 MM
370	2542350107	PISTON RING SET	1	STANDARD
	2542350207	PISTON RING SET	1	OVERSIZE 0.25 MM
	2542350307	PISTON RING SET	1	OVERSIZE 0.50 MM
380	0565180010	CLIP	2	

ROBIN EH25-2 ENGINE — INTAKE AND EXHAUST ASSY.

INTAKE AND EXHAUST ASSY.

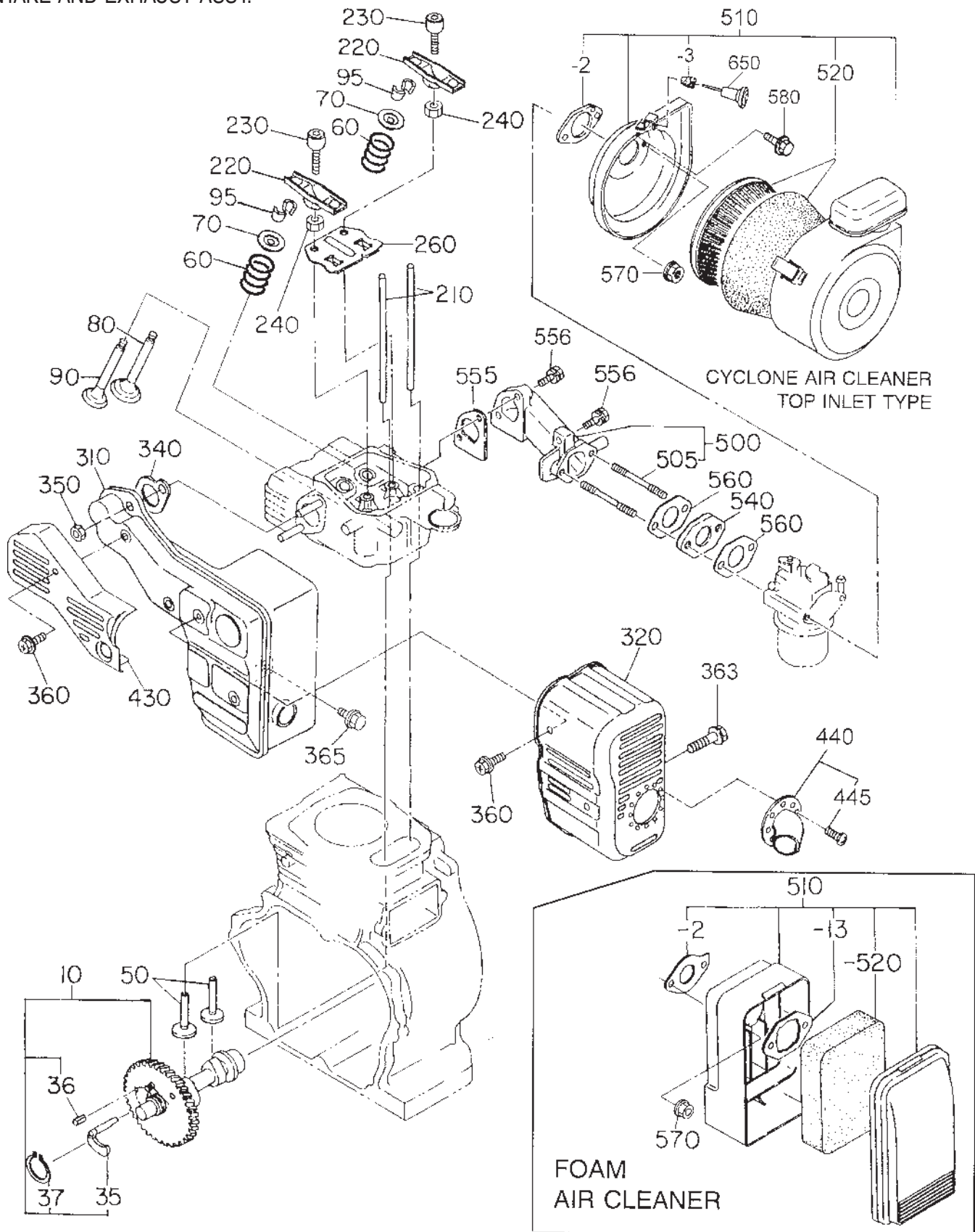

ROBIN EH25-2 ENGINE — INTAKE AND EXHAUST ASSY.

INTAKE AND EXHAUST ASSY.

<u>NO.</u>	<u>PART NO.</u>	<u>PART NAME</u>	<u>QTY.</u>	<u>REMARKS</u>
10	2543170141	CAMSHAFT CP	1	INCLUDES ITEMS W/*
35*	2543640113	RELEASE LEVER	1	
36*	0051904100	SPRING PIN	1	
37*	0031522000	SNAP RING	1	
50	2393330113	TAPPET	2	
60	2463361103	VALVE SPRING	2	
70	2463371103	SPRING RETAINER	2	
80	2703340103	INTAKE VALVE	1	
90	2703350103	EXHAUST VALVE	1	
95	2463550103	COLLET VALVE	4	
210	2703530103	PUSH ROD	2	
220	26136001A3	ROCKER ARM	2	
230	2693580103	BOLT, PIVOT	2	
240	0170060090	NUT	2	
260	2703650103	GUIDE PLATE	1	
310	2703010101	MUFFLER CP	1	
320	2543420111	MUFFLER COVER	1	
340	2463520103	GASKET, MUFFLER	1	
350	0170080030	NUT	2	
360	0152006090	TAPPING BOLT	4	
363	0152060100	TAPPING BOLT	1	
365	0011008160	BOLT AND WASHER ASSY.	1	
430	2703480103	EXHAUST PIPE COVER	1	
440	2463700107	DEFLECTOR ASSY.	1	INCLUDES ITEMS W/+
445+	0150040060	TAPPING SCREW	3	
500	2543300101	INTAKE PIPE CP	1	INCLUDES ITEMS W/%
505%	0105060191	STUD	2	
510	2543261310	AIR CLEANER ASSY.	1	CYCLONE, TOP INLET TYPE
-2	2343600308	PACKING	1	CYCLONE, TOP INLET TYPE
-3	2073269008	GROMMET	1	CYCLONE, TOP INLET TYPE
510	2703260100	AIR CLEANER ASSY.	1	FOAM AIR CLEANER TYPE
-2	2343600308	PACKING	1	FOAM AIR CLEANER TYPE
-13	2703265008	PLATE	1	FOAM AIR CLEANER TYPE
-520	2703261008	CLEANER ELEMENT	1	FOAM AIR CLEANER TYPE
520	2343260407	ELEMENT SET	1	CYCLONE TYPE
540	2343290103	INSULATOR	1	
555	2463600113	GASKET, INTAKE PIPE	1	
556	0011308280	BOLT AND WASHER ASSY.	3	
560	2343590203	GASKET 2, INSULATOR	2	
570	2263921200	NUT AND WASHER ASSY.	2	CYCLONE, TOP INLET TYPE
	0023806000	FLANGE NUT	2	FOAM AIR CLEANER TYPE
580	0011006120	BOLT AND WASHER ASSY.	2	CYCLONE, TOP INLET TYPE
650	2304390101	CHOKE KNOB	1	CYCLONE, TOP INLET TYPE

ROBIN EH25-2 ENGINE — GOVERNOR ASSY.

GOVERNOR ASSY.

<u>NO.</u>	<u>PART NO.</u>	<u>PART NAME</u>	<u>QTY.</u>	<u>REMARKS</u>
10	2544230123	GOVERNOR LEVER	1	
20	2464220123	GOVERNOR SHAFT	1	
30	2544270101	GOVERNOR ROD CP	1	
40	2544280103	ROD SPRING	1	
50	0031306000	CLIP	2	
60	0011406300	BOLT AND WASHER ASSY.	1	
70	0186060020	NUT	1	
80	2544250113	GOVERNOR SPRING	1	
310	2704330200	SPEED CONTROL ASSY.	1	INCLUDES ITEMS W/*
320*	2704330201	SPEED CONTROL CP	1	
330*	2274360103	KNOB	1	
340	2704350103	STOP PLATE	1	
345	0043104250	SCREW	1	
346	2694550303	IDLE SET SPRING	1	
350	2274500203	SPRING WASHER	1	
360	0043106300	SCREW	1	
370	0022706000	NUT	1	
380	0110060050	FLANGE-BOLT	1	
410	2544420123	WIRE BRACKET	1	
440	0043104080	SCREW	1	
450	0022706000	NUT	1	

ROBIN EH25-2 ENGINE — COOLING AND STARTING ASSY.

COOLING AND STARTING ASSY.

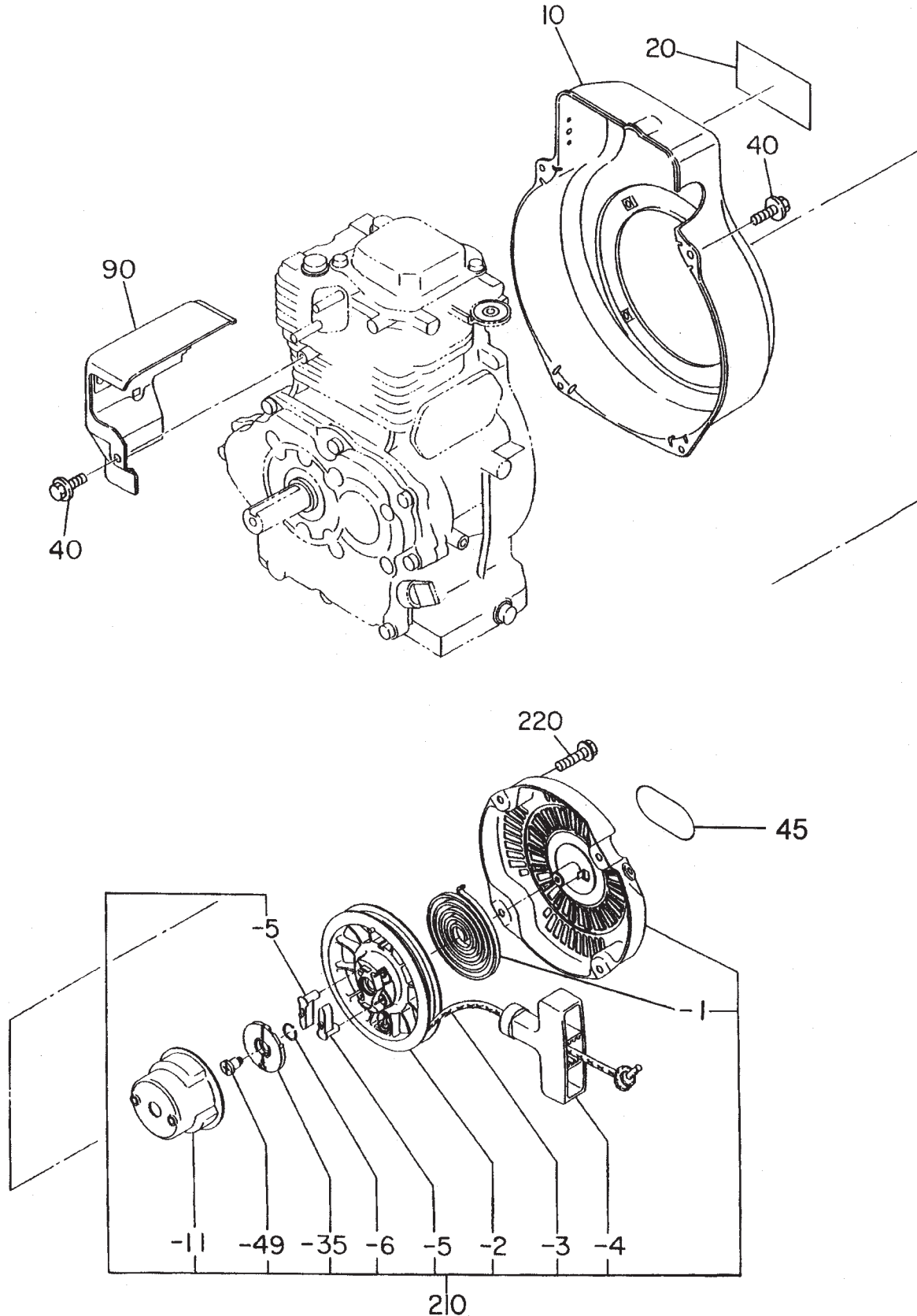

ROBIN EH25-2 ENGINE — COOLING AND STARTING ASSY.

COOLING AND STARTING ASSY.

<u>NO.</u>	<u>PART NO.</u>	<u>PART NAME</u>	<u>QTY.</u>	<u>REMARKS</u>
10	2545345001	BLOWER HOUSING CP	1	
20	2709170303	LABEL, TRADE MARK	1	
40	0110060020	FLANGE BOLT	5	
45	0732004950	LABEL, RECOIL OHV	1	
90	2545270103	HEAD COVER	1	
210	2705020100	RECOIL STARTER ASSY.	1 INCLUDES ITEMS W/*
-1*	2705011508	SPIRAL SPRING	1	
-2*	2705012008	REEL	1	
-3*	2705011008	STARTER ROPE	1	
-4*	2615010008	STARTER KNOB	1	
-5*	2705012508	RATCHET	2	
-6*	2275013108	FRICTION SPRING	1	
-11*	2705014508	STARTER PULLEY	1	
-35*	2705026108	RATCHET GUIDE	1	
-49*	2275015208	SET SCREW	1	
220	0110060010	FLANGE BOLT	4	

ROBIN EH25-2 ENGINE — FUEL TANK ASSY.

FUEL TANK ASSY.

<u>NO.</u>	<u>PART NO.</u>	<u>PART NAME</u>	<u>QTY.</u>	<u>REMARKS</u>
10	2546105011	FUEL TANK CP	1	
20	0732003900	LABEL, CAUTION	1	
30	0430430015	FUEL TANK CAP CP	1	
40	0641360010	FUEL FILTER CP	1	
50	0642008600	FUEL STRAINER ASSY.	1	INCLUDES ITEMS W/*
-1*	0642004110	FILTER	1	
-2*	0642001430	RUBBER PACKING	1	
-3*	0642001410	CLIP	1	
-4*	0642002360	LOCK NUT	1	
-8*	0642002790	LOCK BOLT	1	
-15*	0642003230	SPRING	1	
70	2346260101	FUEL PIPE CP	1	INCLUDES ITEMS W/%
80%	0851060000	RUBBER PIPE	1	
90%	0561110020	HOSE CLAMP	2	
105	0011308200	BOLT AND WASHER ASSY.	4	

ROBIN EH25-2 ENGINE — CARBURETOR ASSY.

CARBURETOR ASSY.

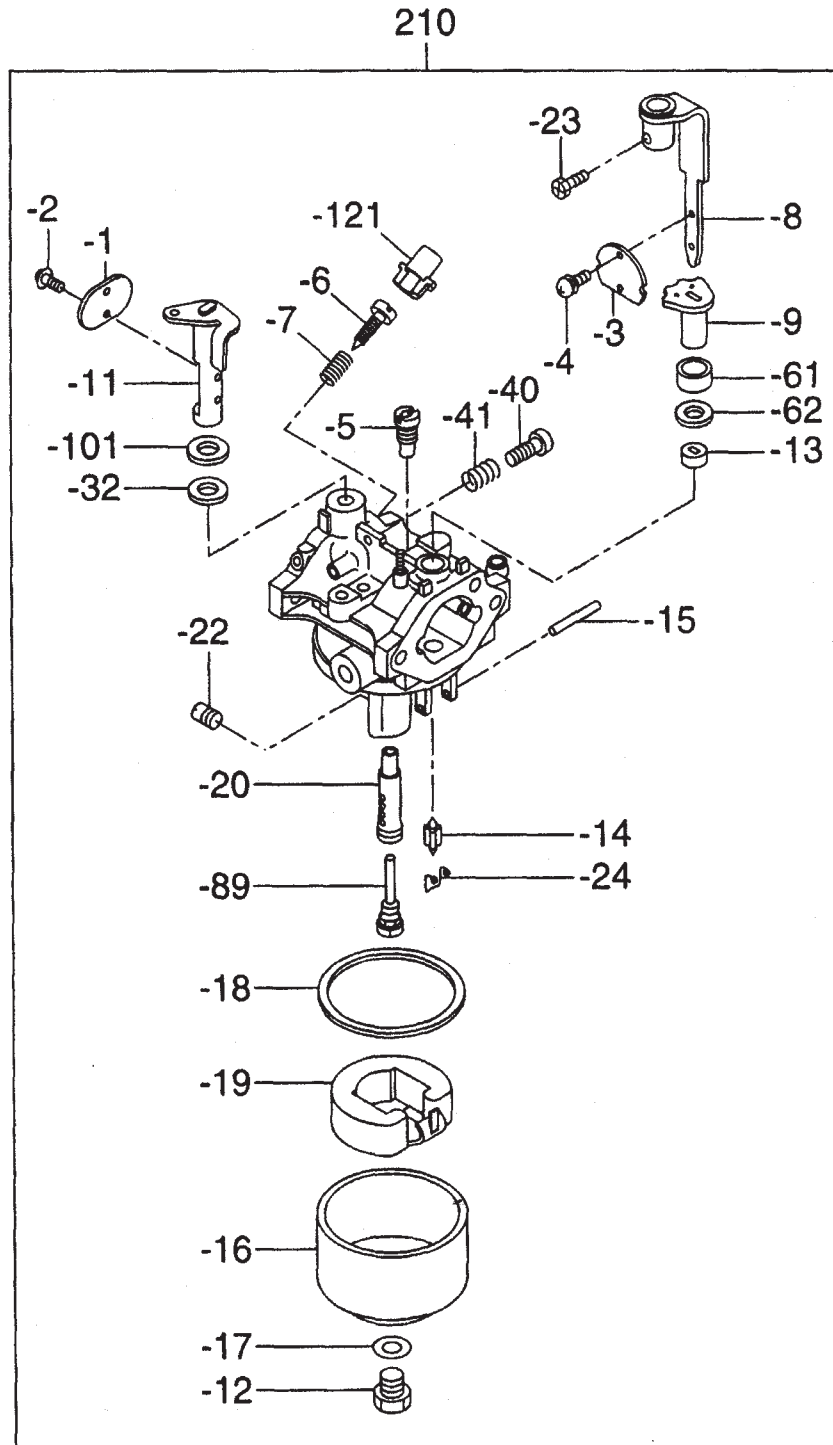

ROBIN EH25-2 ENGINE — CARBURETOR ASSY.

CARBURETOR ASSY.

<u>NO.</u>	<u>PART NO.</u>	<u>PART NAME</u>	<u>QTY.</u>	<u>REMARKS</u>
210	2546252300	CARBURETOR ASSY. CYCLONE, A/C	1	INCLUDES ITEMS W/*
	2546256010	CARBURETOR ASSY. FOAM, A/C	1	INCLUDES ITEMS W/%
-1*%	2396253508	THROTTLE VALVE	1	
-2*%	2096235108	SCREW	2	
-3*%	2546252508	VALVE, CHOKE	1	
-4*%	2376245108	SCREW, PANHEAD	2	
-5*%	2546242008	PILOT JET	1	
-6*%	2466243608	ADJUSTER	1	
-7*%	2306244808	SPRING	1	
-8*	2346252108	CHOKE LEVER ASSY.	1	CYCLONE, TOP INLET TYPE
%	2346252008	CHOKE LEVER ASSY.	1	FOAM AIR CLEANER TYPE
-9*	2396256008	RING	1	CYCLONE, TOP INLET TYPE
%	2346255008	RING	1	FOAM AIR CLEANER TYPE
-11*	2546253108	SHAFT ASSY., THROTTLE	1	CYCLONE, TOP INLET TYPE
%	2546253008	SHAFT ASSY., THROTTLE	1	FOAM AIR CLENAER TYPE
-12*%	2246254408	BOLT	1	
-13*%	2266255008	RING	1	
-14*%	2246231208	NEEDLE VALVE ASSY.	1	
-15*%	2146251508	FLOAT PIN	1	
-16*%	2246255208	FLOAT CHAMBER BODY	1	
-17*%	2076234508	INSERT WASHER	1	
-18*%	2066254008	PACKING, CHAMBER	1	
-19*%	2346250608	FLOAT ASSY.	1	
-20*%	2546244008	MAIN NOZZLE	1	
-22*	2546240308	MAIN JET	1	CYCLONE, TOP INLET TYPE
%	2546240208	MAIN JET	1	FOAM AIR CLEANER TYPE
-23*	2466245508	BOLT	1	CYCLONE, TOP INLET TYPE
-24*	2246256918	CLIP	1	CYCLONE, TOP INLET TYPE
%	2266270118	CLIP	1	FOAM AIR CLEANER TYPE
-32*	1066239208	SEAL	1	CYCLONE, TOP INLET TYPE
-40*%	2466243508	ADJUST SCREW	1	
-41*%	2306244608	SPRING	1	
-61*	2476255008	CAP	1	CYCLONE, TOP INLET TYPE
-62*	2366268008	SEAL	1	CYCLONE, TOP INLET TYPE
-89*%	2466242508	GUIDE HOLDER	1	
-101*	1566235108	PACKING	1	CYCLONE, TOP INLET TYPE
-121*	2466255108	CAP	1	

ROBIN EH25-2 ENGINE — FLYWHEEL AND IGNITION ASSY.

FLYWHEEL AND IGNITION ASSY.

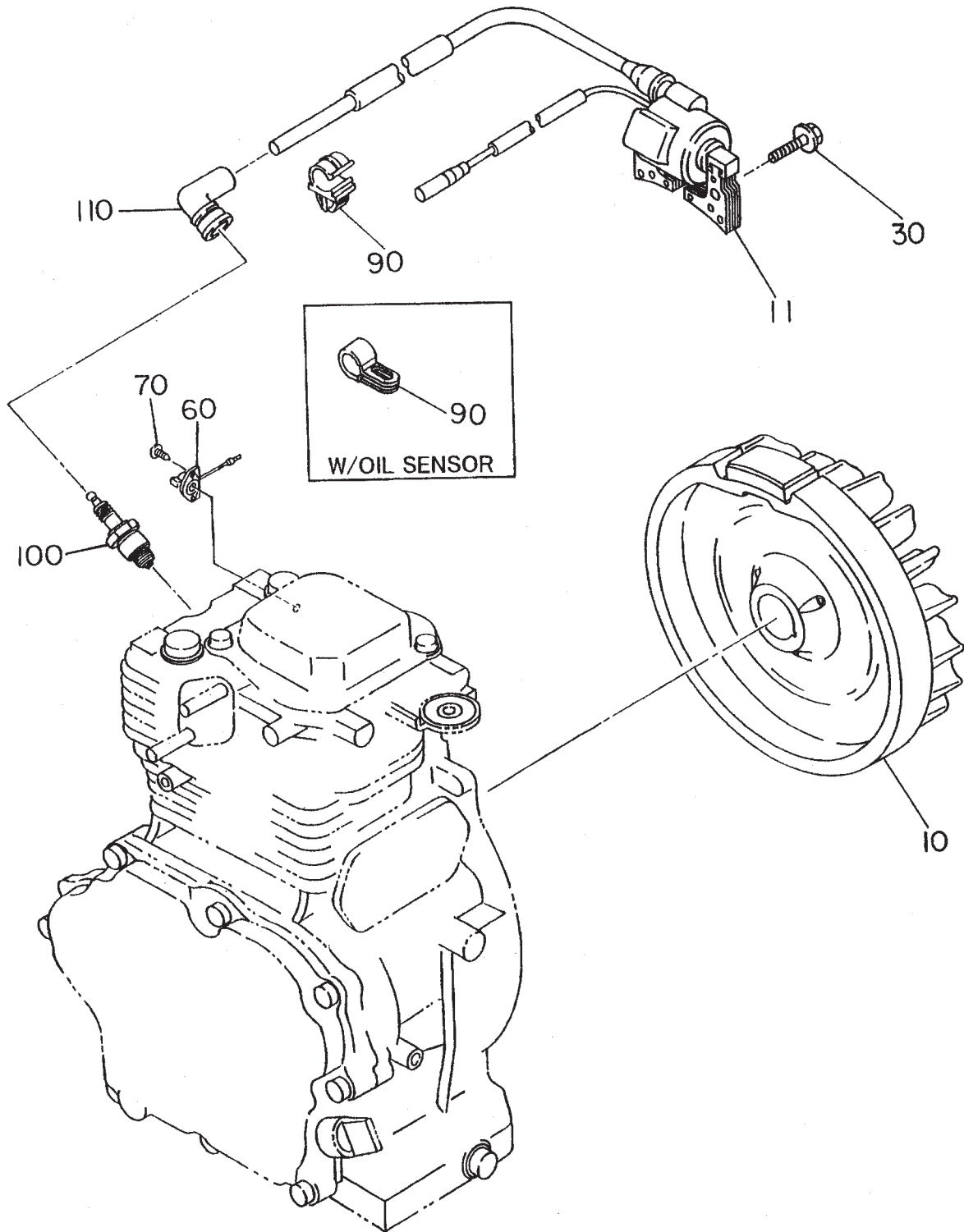

ROBIN EH25-2 ENGINE — FLYWHEEL AND IGNITION ASSY.

FLYWHEEL AND IGNITION ASSY.

<u>NO.</u>	<u>PART NO.</u>	<u>PART NAME</u>	<u>QTY.</u>	<u>REMARKS</u>
10	2347020111	FLYWHEEL CP	1	
11	2547943021	IGNITION COIL CP	1	
30	0011406250	BOLT AND WASHER ASSY.	2	
60	0660000361	SWITCH ASSY.	1	
70	0150040090	TAPPING SCREW	2	
90	0566000190	CLAMP	1	
	0566120050	CLAMP	1 W/OIL SENSOR
100	0650140031	SPARK PLUG	1 NGK B-6HS
	0650141030	SPARK PLUG	1 CHAMPION (L86C)
110	0655000051	SPARK PLUG CAP	1	

ROBIN EH25-2 ENGINE — OIL SENSOR ASSY.

OIL SENSOR ASSY.

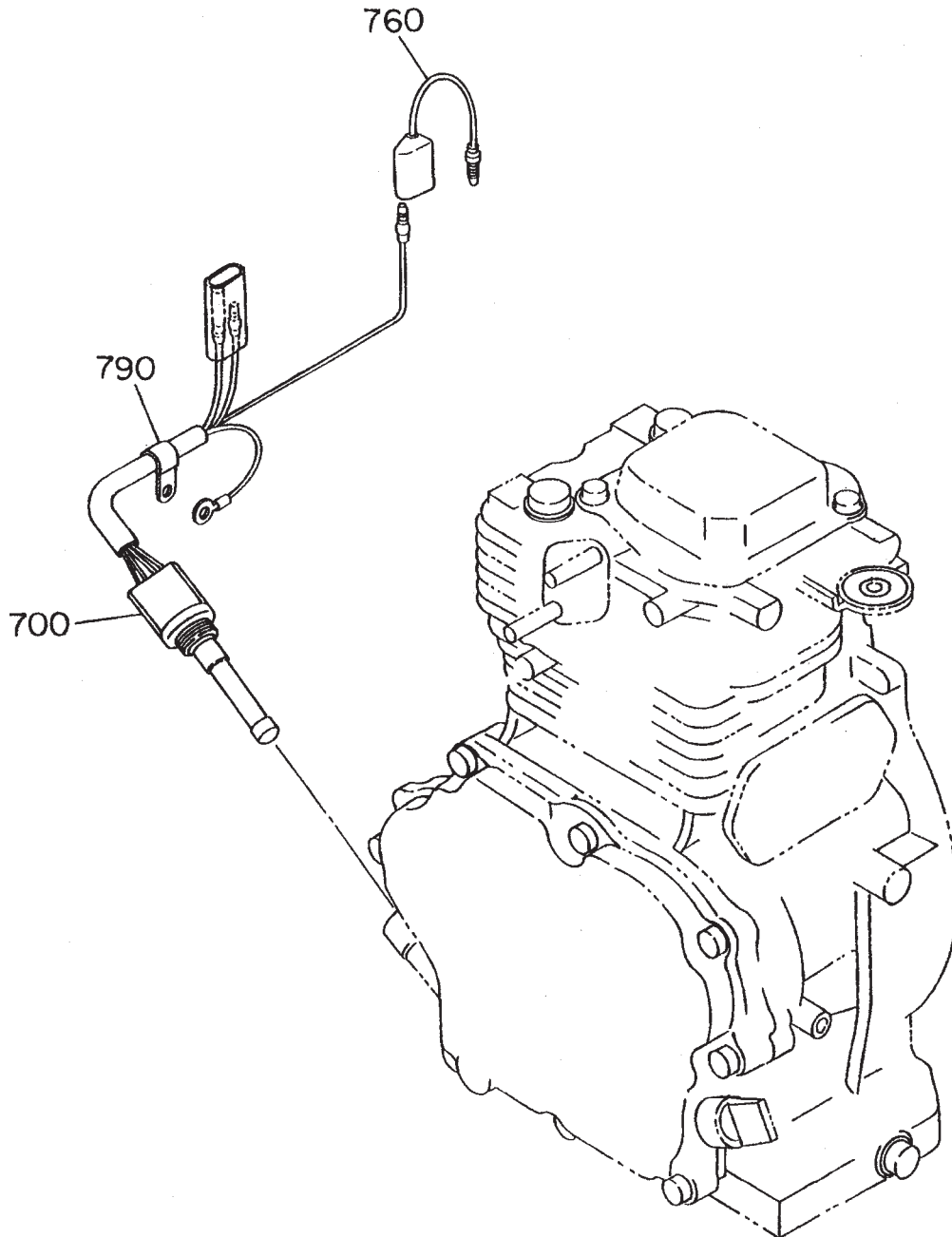

ROBIN EH25-2 ENGINE — OIL SENSOR ASSY.

OIL SENSOR ASSY.

<u>NO.</u>	<u>PART NO.</u>	<u>PART NAME</u>	<u>QTY.</u>	<u>REMARKS</u>
700	KS31102801	OIL SENSOR CP 19	1	W/OIL SENSOR
760	2147312201	WIRE 22 CP	1	W/OIL SENSOR
790	2147900301	CLAMP CP	1	W/OIL SENSOR

TERMS AND CONDITIONS OF SALE — PARTS

PAYMENT TERMS

Terms of payment for parts are net 30 days.

FREIGHT POLICY

All parts orders will be shipped collect or prepaid with the charges added to the invoice. All shipments are F.O.B. point of origin. Multiquip's responsibility ceases when a signed manifest has been obtained from the carrier, and any claim for shortage or damage must be settled between the consignee and the carrier.

MINIMUM ORDER

The minimum charge for orders from Multiquip is \$15.00 net. Customers will be asked for instructions regarding handling of orders not meeting this requirement.

RETURNED GOODS POLICY

Return shipments will be accepted and credit will be allowed, subject to the following provisions:

1. A Returned Material Authorization must be approved by Multiquip prior to shipment.
2. To obtain a Return Material Authorization, a list must be provided to Multiquip Parts Sales that defines item numbers, quantities, and descriptions of the items to be returned.
 - a. The parts numbers and descriptions must match the current parts price list.
 - b. The list must be typed or computer generated.
 - c. The list must state the reason(s) for the return.
 - d. The list must reference the sales order(s) or invoice(s) under which the items were originally purchased.
 - e. The list must include the name and phone number of the person requesting the RMA.
3. A copy of the Return Material Authorization must accompany the return shipment.
4. Freight is at the sender's expense. All parts must be returned freight prepaid to Multiquip's designated receiving point.

5. Parts must be in new and resalable condition, in the original Multiquip package (if any), and with Multiquip part numbers clearly marked.
6. The following items are not returnable:
 - a. Obsolete parts. (If an item is in the price book and shows as being replaced by another item, it is obsolete.)
 - b. Any parts with a limited shelf life (such as gaskets, seals, "O" rings, and other rubber parts) that were purchased more than six months prior to the return date.
 - c. Any line item with an extended dealer net price of less than \$5.00.
 - d. Special order items.
 - e. Electrical components.
 - f. Paint, chemicals, and lubricants.
 - g. Decals and paper products.
 - h. Items purchased in kits.
7. The sender will be notified of any material received that is not acceptable.
8. Such material will be held for five working days from notification, pending instructions. If a reply is not received within five days, the material will be returned to the sender at his expense.
9. Credit on returned parts will be issued at dealer net price at time of the original purchase, less a 15% restocking charge.
10. In cases where an item is accepted, for which the original purchase document can not be determined, the price will be based on the list price that was effective twelve months prior to the RMA date.
11. Credit issued will be applied to future purchases only.

PRICING AND REBATES

Prices are subject to change without prior notice. Price changes are effective on a specific date and all orders received on or after that date will be billed at the revised price. Rebates for price declines and added charges for price increases will not be made for stock on hand at the time of any price change.

Multiquip reserves the right to quote and sell direct to Government agencies, and to Original Equipment Manufacturer accounts who use our products as integral parts of their own products.

SPECIAL EXPEDITING SERVICE

A \$35.00 surcharge will be added to the invoice for special handling including bus shipments, insured parcel post or in cases where Multiquip must personally deliver the parts to the carrier.

LIMITATIONS OF SELLER'S LIABILITY

Multiquip shall not be liable hereunder for damages in excess of the purchase price of the item with respect to which damages are claimed, and in no event shall Multiquip be liable for loss of profit or good will or for any other special, consequential or incidental damages.

LIMITATION OF WARRANTIES

No warranties, express or implied, are made in connection with the sale of parts or trade accessories nor as to any engine not manufactured by Multiquip. Such warranties made in connection with the sale of new, complete units are made exclusively by a statement of warranty packaged with such units, and Multiquip neither assumes nor authorizes any person to assume for it any other obligation or liability whatever in connection with the sale of its products. Apart from such written statement of warranty, there are no warranties, express, implied or statutory, which extend beyond the description of the products on the face hereof.

Effective: February 22, 2006

OPERATION AND PARTS MANUAL

HERE'S HOW TO GET HELP

PLEASE HAVE THE MODEL AND SERIAL
NUMBER ON-HAND WHEN CALLING

UNITED STATES

Multiquip Corporate Office

18910 Wilmington Ave. Tel. (800) 421-1244
Carson, CA 90746 Fax (800) 537-3927
Contact: mq@multiquip.com

Mayco Parts

800-306-2926 Fax: 800-672-7877
310-537-3700 Fax: 310-637-3284

Service Department

800-421-1244 Fax: 310-537-4259
310-537-3700

MQ Parts Department

800-427-1244 Fax: 800-672-7877
310-537-3700 Fax: 310-637-3284

Warranty Department

800-421-1244, Ext. 279 Fax: 310-537-1173
310-537-3700, Ext. 279

Technical Assistance

800-478-1244 Fax: 310-631-5032

MEXICO

MQ Cipsa

Carr. Fed. Mexico-Puebla KM 126.5 Tel: (52) 222-225-9900
Momoxpan, Cholula, Puebla 72760 Mexico Fax: (52) 222-285-0420
Contact: pmastretta@cipsa.com.mx

UNITED KINGDOM

Multiquip (UK) Limited Head Office

Unit 2, Northpoint Industrial Estate, Tel: 0161 339 2223
Global Lane, Fax: 0161 339 3226
Dukinfield, Cheshire SK16 4UJ
Contact: sales@multiquip.co.uk

CANADA

Multiquip

4110 Industriel Boul. Tel: (450) 625-2244
Laval, Quebec, Canada H7L 6V3 Tel: (877) 963-4411
Contact: jmartin@multiquip.com Fax: (450) 625-8664

© COPYRIGHT 2010, MULTIQUIP INC.

Multiquip Inc, the MQ logo and the Whiteman logo are registered trademarks of Multiquip Inc. and may not be used, reproduced, or altered without written permission. All other trademarks are the property of their respective owners and used with permission.

This manual **MUST** accompany the equipment at all times. This manual is considered a permanent part of the equipment and should remain with the unit if resold.

The information and specifications included in this publication were in effect at the time of approval for printing. Illustrations, descriptions, references and technical data contained in this manual are for guidance only and may not be considered as binding. Multiquip Inc. reserves the right to discontinue or change specifications, design or the information published in this publication at any time without notice and without incurring any obligations.

Your Local Dealer is:

