

DDC
Digital Document Copier
Network **52/62n**

User's Guide

©1999 Hitachi Koki Imaging Solutions, Inc.
1757 Tapo Canyon Road
Simi Valley, CA 93063
336686-001, Rev. A
August, 1999

© 1999 Hitachi Koki Imaging Solutions, Inc. All rights reserved.

No part of this document may be reproduced without the expressed permission of Hitachi Koki Imaging Solutions, Inc.

The material in this document is for informational purposes and is subject to change without notice. Hitachi Koki Imaging Solutions, Inc., assumes no responsibility for errors or omissions in this document. No liability is assumed for any damages resulting from the use of the information it contains.

TRADEMARK

Digital Document Copier, DDC, DDC 52n, DDC 62n, and their associated logo marks, are trademarks of Hitachi Koki Imaging Solutions, Inc.

Hitachi and the Hitachi logo are trademarks of Hitachi, Ltd. All rights reserved.

All other trademarks are the property of their owners.

NOTICE TO USER

In an effort to meet the demands of a rapidly changing technology, the manufacturer is continually developing new features and functions to meet your changing printing or printer needs. As a result, this manual may not exactly reflect future changes made to the product. Please be sure to consult all manual updates or addenda when using this product's documentation.



EPA POLLUTION PREVENTER

As an ENERGY STAR® Partner, Hitachi Koki Imaging Solutions, Inc. has determined that this copier meets the ENERGY STAR® Guidelines for energy efficiency.

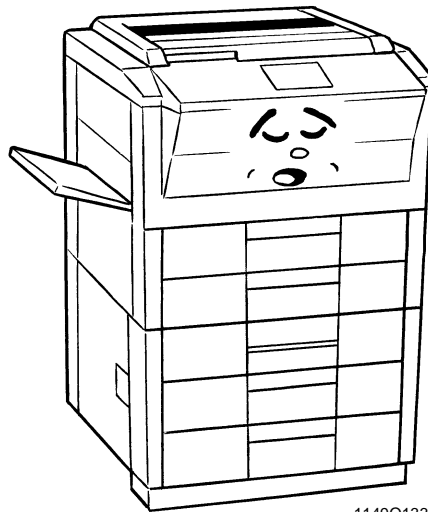

1149O133AA

What is an Energy Star Copier?

Energy Star Copiers have a feature that allows them to automatically turn off or “go to sleep” after a period of inactivity, ensuring night and weekend shut off. This auto-feature can reduce a copier’s annual electricity costs by over 60 percent. In addition, high speed copiers will be set to automatically make double-sided copies. An organization’s paper costs can be reduced by \$60 a month and the volume of paper sent into the waste stream will decline. It takes 10 times more energy to produce a piece of paper than it does to make a single copy on a copier. Therefore, using less paper also means decreased national energy consumption.

Using the Copier Properly

To ensure the optimum performance of the copier, follow the precautions listed below.

- Never place a heavy object on the copier.
- Never subject the copier to shocks.
- Never open any doors or turn the copier off while the copier is making copies.
- Never bring any magnetized object near the copier.
- Never use flammable sprays, liquids or gases near the copier.
- Never modify the copier, as a fire or electrical shock could result.
- Never remove any panel or cover which is secured. The copier contains high voltage components which can cause electrical shock.
- Never tamper with the laser mechanism in laser-equipped models, as blindness or other injury may result.
- Never drop paper clips, staples or other small pieces of metal through the vents or other openings in the copier, as a fire or electrical shock can result.
- Never place containers of liquid on the copier. If liquids get inside the copier, they can cause fire or electrical shock. If a piece of metal or any liquid gets inside the copier, immediately turn the copier off, unplug the power cord and call your technical representative. A fire or electrical shock can result if the copier remains plugged in or is operated after metal or liquid gets inside.
- Never leave the copier running if it becomes unusually hot, or if smoke or an unusual odor or noise is detected. Should any of these conditions occur, immediately turn the copier off, unplug the power cord and call your technical representative. A fire or electrical shock can result if the copier remains plugged in under any of these conditions.
- Always insert the power plug all the way into the outlet.
- Always make sure that the outlet is visible, clear of the copier or copier cabinet.
- Always provide good ventilation when making a large number of continuous copies.
- Never pull on the power cord, and always hold the plug when unplugging the power cord. A damaged cord could result in a fire or cause an electrical shock.
- Never unplug the power cord with a wet hand, as it could cause an electrical shock.
- Always unplug the power cord before moving the copier. Moving the copier with the power cord plugged in can damage the cord resulting in a fire or causing an electrical shock.
- Always unplug the power cord when the copier is not going to be used for a long time.
- Never place a heavy object on the power cord, or pull or bend it, as a fire or electrical shock can result.
- Always ensure that the copier does not sit on or roll onto the power cord or communications cable of other electrical equipment, as malfunctioning equipment or a fire could result.
- Always ensure that the power cord or communications cable of other electrical equipment does not become wedged into the copier mechanism, as malfunctioning equipment or a fire could result.
- Always use the correct power voltage, as improper voltage can cause a fire or electrical shock.

Using the Copier Properly

- Never use a multiple outlet adapter, as a fire or electrical shock can result.
- Should the power cord become damaged, immediately turn the copier off, unplug the power cord and call your technical representative. A damaged cord can result in a fire or cause an electric shock.
- If an extension cord is needed, use one with a greater rated capacity than the maximum power requirements of the copier. The use of an extension cord that falls short of supporting the maximum power requirements can result in overheating or a fire.
- Always unplug the copier whenever anything unusual is observed during operation. Make sure that the outlet is nearby and clear of the copier and furniture.

=Locate the Copier in a Well Ventilated Room=

A negligible amount of ozone is generated during normal operation of this copier. An unpleasant odor may, however, be created in poorly ventilated rooms during extensive copier operations. For a comfortable, healthy and safe operating environment, it is recommended that the room be well ventilated.

=Placer le copieur dans une pièce largement ventilée=

Une quantité d'ozone négligeable est dégagée pendant le fonctionnement du copieur quand celui-ci est utilisé normalement. Cependant, une odeur désagréable peut être ressentie dans les pièces dont l'aération est insuffisante et lorsqu'une utilisation prolongée du copieur est effectuée. Pour avoir la certitude de travailler dans un environnement réunissant des conditions de confort, santé et de sécurité, il est préférable de bien aérer la pièce où se trouve le copieur.

Thank you for choosing Hitachi Koki Imaging Solutions, Inc. quality. For over 30 years Hitachi Koki Imaging Solutions, Inc. has been a leader on the forefront of office equipment technology and service. Our desire has always been to bring you highly reliable products. We pledge to continue to provide you, our customer, with our state of the art equipment, as well as full customer service for all our products. We look forward to a long healthy relationship with you and our company. If you have any questions or comments about Hitachi Koki Imaging Solutions, Inc., our product or service, please let us know. Thank you again.

This operator's manual explains how to operate the copier and replenish its supplies. It also gives some troubleshooting tips as well as general precautions to be observed when operating the copier.

To ensure the best performance and effective use of your copier, read this manual carefully until you familiarize yourself thoroughly with the copier's operation and features. After you have read through the manual, keep it ready for reference.

Please use this manual as a quick and handy reference tool for immediately clarifying any questions which may arise.

MC-F01

WARNING

This equipment has been tested and found to comply with the limits for a Class A digital device, pursuant to Part 15 of the FCC Rules. These limits are designed to provide reasonable protection against harmful interference when the equipment is operated in a commercial environment. This equipment generates, uses, and can radiate radio frequency energy and if not installed and used in accordance with the instruction manual, may cause harmful interference to radio communications. Operation of this equipment in a residential area is likely to cause harmful interference in which case the user will be required to correct the interference at his own expense.

The design and production of this unit conforms to FCC Regulations, and any changes or modifications must be registered with the FCC and are subject to FCC control. Any changes made by the purchaser or user without first contacting the manufacturer will be subject to penalty under FCC regulations.

FCC-F01

This Class A digital apparatus complies with Canadian ICES-003.

Cet appareil numérique de la classe A est conforme à la norme NMB-003 du Canada.

IC-F03

Contents

Terms and Symbols for the Type of Originals and Copy Paper	v
Feeding Direction (copy paper path)	v
Safety Precautions	vi
Laser Safety Label	vi
Safety Information	vii

Chapter 1

Safety Notes

1. Installing the Copier	
Installation Site	1-2
Power Source	1-2
Space Requirements	1-2
2. Precautions for Use	
Operating Environment	1-3
Using the Copier Properly	1-3
Moving the Copier	1-3
Care of Copier Supplies	1-3
Note on making multiple copies	1-4
Legal Restrictions on Copying	1-4

Chapter 2

Getting to Know Your Copier

1. Typical Copies You Can Make with Your Copier	
Typical copies you can make with your copier	2-2
2. System Overview	
System Overview	2-6
3. Copier Parts and Accessories	
Outside the copier	2-8
Copier Accessories	2-10
Precautions When Using a Finisher	2-11
Inside the Copier	2-13
4. Control Panel Keys and Indicators	
Control panel keys and indicators	2-14
5. Using the Touch Panel	
What is the Touch Panel?	2-16
How the Screen is Organized	2-16
Operating the Touch Panel	2-17
6. Turning ON and OFF and Initial Mode	
Turning ON and OFF	2-18
When the Copier is Turned ON	2-18
Initial Mode	2-18
7. Auxiliary Functions	
Auxiliary functions	2-19
Entering the Access Number	2-20

Chapter 3

Making Copies

1. Basic Copying Overview	
Basic Copying Overview	3-2
2. Placing the Original	
Using the Electronic Document Handler	3-4
Not Using the Document Handler	3-6
3. Selecting the Paper	

Copy Paper Size	3-9
Manual Bypass Copying	3-11
4. Selecting the Zoom	
Zoom Ratio	3-14
5. Selecting the Finishing	
Finishing Functions	3-20
Selecting the Finishing Function	3-22
Loading the Originals	3-32
Auto Dual Function	3-34
6. Selecting the Original ► Copy Type	
Original ► Copy Types	3-35
Selecting the Original ► Copy Type	3-37
Some Precautions for Making Copies	3-42
7. Selecting the Density	
Image Density	3-43
8. Auxiliary Functions	
Cover	3-45
Page Insertion	3-47
OHP Interleaving	3-51
File Margin	3-55
Edge/Frame Erase	3-57
Image Repeat	3-59
Number Stamping	3-61
Image Stamping	3-65
9. Selecting Mixed Orig. Detection and Other Functions	
Mixed Orig. Detection and Other Functions	3-67
10. Selecting the Job Functions	
Memory Recall	3-70
Reserve	3-71
Job List	3-72
11. Typical Function Combinations	
Making Different Types of Copy	3-75

Chapter 4

Using the Utility Mode

1. Job Memory Input and Job Recall	
Job Memory Input	4-2
Recalling a Job from Memory	4-5
2. Zoom Memory Input	
Storing a Zoom Ratio	4-6
3. Image Memory Input	
Image Memory Input	4-8
4. Meter Count and Toner Replenisher	
Meter Count	4-13
Toner Replenisher	4-13
5. User's Choice	
User's Choice Functions	4-14
Making the User's Choice Settings	4-21
Copy Track Function	4-22

Chapter 5	When a Message Appears	
	1. When the Message “The current Paper Drawer is empty.” Appears	
	Adding paper	5-2
	2. When the Message “Replenish Toner.” Appears	
	Replacing the Toner Bottle	5-6
	3. When the Message “The Staple Cartridge is empty.” Appears	
	Replacing the Staple Cartridge	5-8
	4. When the Message “A paper misfeed has been detected.” Appears	
	Misfeed Location Displays	5-10
	Misfeed Clearing Procedures	5-12
	6. What Does Each Message Mean?	
	What does each message mean?	5-28
Chapter 6	Troubleshooting	
	1. When This Type of Copy is Produced	
	When this type of copy is produced	6-2
	2. The Copier is not Functioning as Designed	
	The copier is not functioning as designed	6-4
Chapter 7	Miscellaneous	
	1. Specifications	
	Specifications	7-2
	2. Care of the Copier	
	Cleaning	7-5
	3. Function Combination Matrix	
	Function combination matrix	7-7
	Conditions for Combined Functions	7-9
	4. Description of Paper Size and Zoom Ratio Table	
	Description of paper size and zoom ratio table	7-10
Index		

Terms and Symbols for the Type of Originals and Copy Paper

A few special terms and symbols are used in this manual to designate types of originals and copy paper. This page explains about these terms and symbols.

Feeding Direction (copy paper path)

In this copier system, copy paper is taken up from the right-hand side of the copier and fed through the copier toward the left-hand side, face up onto the Copy Tray. In the figure below, the direction in which the copy paper is fed, as indicated by the arrow, is called the “feeding direction.”

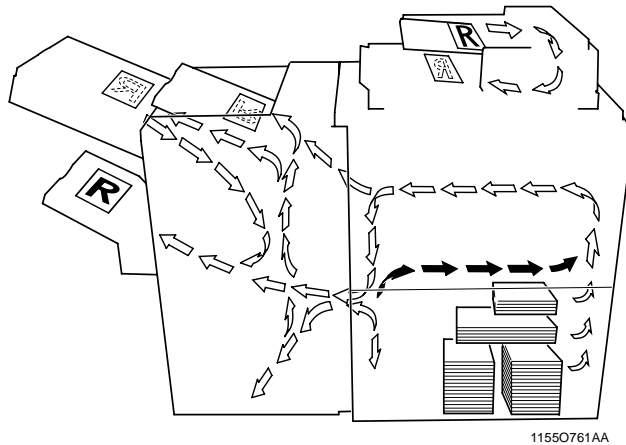

“Width” and “Length”

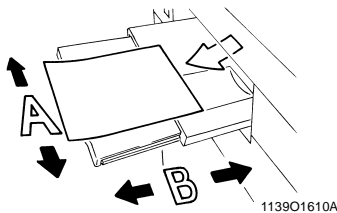



When we talk about the size of the original or copy, we call side A “width” and side B “length.”

A: Width
B: Length

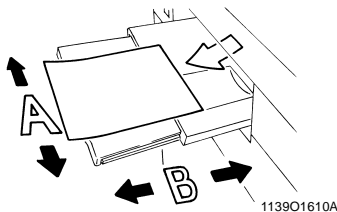
Terms and Symbols Used



<Lengthwise  >

When the original or copy has a “length” longer than its “width,” we call it “lengthwise” and use symbol “L” or “.

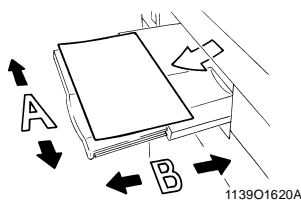

<Crosswise  >

When the original or copy has a “length” shorter than its “width,” we call it “crosswise” and use symbol “C” or “.

Safety Precautions

Laser Safety Label

A laser safety label is attached to the outside of the copy machine as shown below.

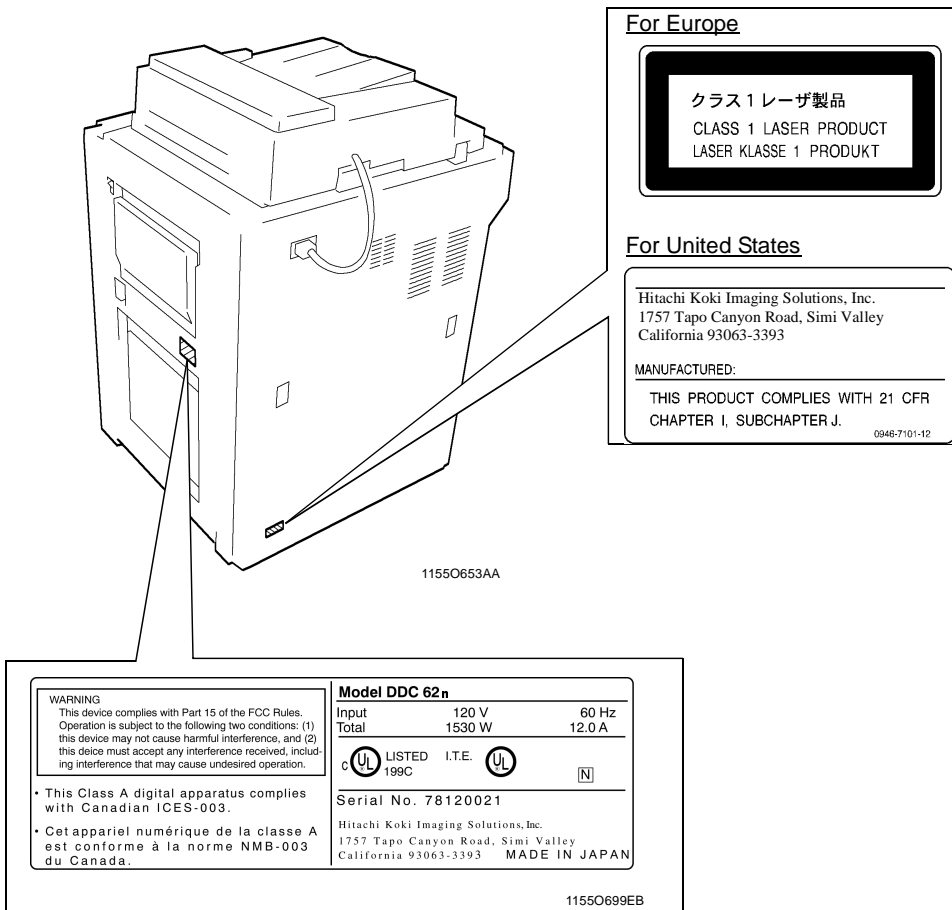

Sample Only

The Manufacturer's Name Plate is affixed at the position illustrated above.
Please write down the Model Name and Serial No. of your copier here.

Model:
Serial No.

Safety Information

This copy machine is a digital copy machine which operates by means of a laser. There is no possibility of danger from the laser, provided the copy machine is operated according to the instructions in this manual.

Since radiation emitted by the laser is completely confined within protective housing, the laser beam cannot escape from the machine during any phase of user operation.

This copy machine is certified as a Class 1 laser product. This means the copy machine does not produce hazardous laser radiation.

**LUOKAN 1 LASERLAITE
KLASS 1 LASER APPARAT**

CAUTION: The use of controls, adjustments or performance of procedures other than those specified in this manual may result in hazardous radiation exposure. Because of this, we strongly recommend that you operate your copy machine only as described in this documentation.

For United States Users

Laser Safety

This copy machine is certified as a Class 1 Laser product under the U.S. Department of Health and Human Services (DHHS) Radiation Performance Standard according to the Radiation Control for Health and Safety Act of 1968. This means that the copy machine does not produce hazardous laser radiation.

CDRH Regulations

The Center for Devices and Radiological Health (CDRH) of the U.S. Food and Drug Administration implemented regulations for laser products on August 2, 1976. Compliance is mandatory for products marketed in the United States. The label shown below indicates compliance with the CDRH regulations and must be attached to laser products marketed in the United States.

WARNING: Use of controls, adjustments or performance of procedures other than those specified in this manual may result in hazardous radiation exposure.

Internal Laser Radiation

Maximum Radiation Power: 15mW × 2 diodes

Wave Length: 780nm

Safety Precautions

For European Users

WARNING: Use of controls, adjustments or performance of procedures other than those specified in this manual may result in hazardous radiation exposure.

This is a semiconductor laser. The maximum power of the laser diode is 15mW and the wavelength is 780nm. (Two provided.)

For Denmark Users

ADVARSEL

Usynlig laserstråling ved åbning, når sikkerhedsafbrydere er ude af funktion.
Undgå udsættelse for stråling.

Klasse 1 laser produkt der opfylder IEC825 sikkerheds kravene.

For Finland, Sweden Users

VAROITUS

Laitteen käyttäminen muulla kuin tässä käyttöohjeessa mainitulla tavalla saattaa altistaa käyttäjän turvallisuusluokan 1 ylittävälle näkymättömälle lasersäteilylle.

VARNING

Om apparaten används på annat sätt än i denna bruksanvisning specificerats, kan användaren utsättas för osynlig laserstrålning, som överskrider gränsen för laserklass 1.

For Norway Users

ADVERSEL

Dersom apparatet brukes på annen måte enn spesifisert i denne bruksanvisning, kan brukeren utsettes for usynlig laserstråling som overskrider grensen for laser klasse 1.

Dette en halvleder laser. Maksimal effekt till laserdiode er 15mW og bølgelengde er 780nm.

Chapter 1

Safety Notes

1. Installing the Copier

Installation Site

To ensure utmost safety and prevent possible malfunctions of the copier, install it in a location which meets the following requirements.

- ◆ A place away from a curtain or the like that may catch fire and burn easily.
- ◆ An area where there is no possibility of being splashed with water or other types of liquid.
- ◆ An area free from direct sunlight.
- ◆ A place out of the direct air stream of an air conditioner, heater, or ventilator.
- ◆ A well-ventilated place.
- ◆ A dry place.
- ◆ A dust-free location.
- ◆ An area not subject to undue vibration.
- ◆ A stable and level location.
- ◆ A place where ammonia or other organic gas is not generated.
- ◆ A place which does not put the operator in the direct stream of exhaust from the copier.
- ◆ A place which is not near any kind of heating device.

Power Source

The power source voltage requirements are as follows:

- ◆ Use a power source with little voltage fluctuation.
 - Voltage Fluctuation : Within $\pm 10\%$
 - Frequency Fluctuation : Within $\pm 0.3\%$

Space Requirements

To ensure easy copier operation, supply replacements, and service maintenance, adhere to the recommended space requirements detailed below. Allow a clearance of 6" or more at the back of the copier as there is a ventilation duct.

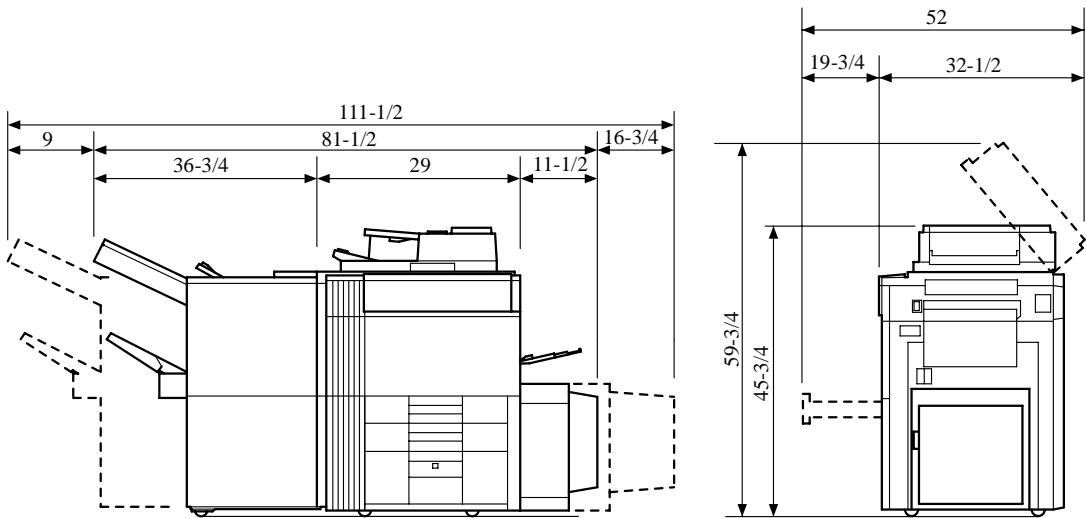

<With EDH-1, FN-3 and C-304L mounted>

Unit: Inch

11550724AB

2. Precautions for Use

Operating Environment

The operating environmental requirements of the copier are as follows:

Temperature : 10°C to 32°C (50°F to 90°F) with a fluctuation of 10°C (18°F) per hour.

Humidity : 15% to 85% with a fluctuation of 10% per hour.

Using the Copier Properly

To ensure optimum performance of the copier, follow the precautions listed below.

- ◆ NEVER place a heavy object on the copier or subject the copier to shocks.
- ◆ NEVER open any doors, or turn OFF the copier while the copier is making copies.
- ◆ NEVER bring any magnetized object or use flammable sprays near the copier.
- ◆ NEVER remodel the copier, as a fire or electrical shock could result.
- ◆ ALWAYS insert the power plug all the way into the outlet.
- ◆ ALWAYS make sure that the outlet is visible, clear of the copier or copier cabinet.
- ◆ ALWAYS provide good ventilation when making a large number of continuous copies.

NOTE

= *Locate the Copier in a Well Ventilated Room* =

A negligible amount of ozone is generated during normal operation of this copier. An unpleasant odor may, however, be created in poorly ventilated rooms during extensive copier operations. For a comfortable, healthy, and safe operating environment, it is recommended that the room be well ventilated.

REMARQUE

= *Placer le copieur dans une pièce largement ventilée* =

Une quantité d'ozone négligable est dégagée pendant le fonctionnement du copieur quand celui-ci est utilisé normalement. Cependant, une odeur désagréable peut être ressentie dans les pièces dont l'aération est insuffisante et lorsque une utilisation prolongée du copieur est effectuée. Pour avoir la certitude de travailler dans un environnement réunissant des conditions de confort, santé et de sécurité, il est préférable de bien aérer la pièce où se trouve le copieur.

Moving the Copier

If you need to transport the copier over a long distance, consult your Technical Representative.

Care of Copier Supplies

Use the following precautions when handling the copier supplies (toner, paper, etc.).

- ◆ Store the paper, toner, and other supplies in a place free from direct sunlight and away from any heating apparatus. Keep them in a dry, cool, clean environment.
- ◆ Store paper, which has been removed from its wrapper but not loaded into the drawer, in a sealed plastic bag in a cool, dark place.
- ◆ Keep supplies out of the reach of children.
- ◆ If your hands become soiled with toner, wash them with soap and water immediately.

Note on making multiple copies

If the fusing temperature drops excessively during a multi-copy cycle, there is a possibility that the copying speed will be reduced. The copying speed will automatically return to normal when the fusing temperature rises enough to ensure good fusing performance.

Legal Restrictions on Copying

Certain types of documents must never be copied by the copier for the purpose or with the intent to pass copies of such documents off as the original. The following is not a complete list but is meant to be used as a guide to responsible copying.

Financial Instruments

- Personal Checks
- Travelers Checks
- Money Orders
- Certificates of Deposit
- Bonds or other Certificates of Indebtedness
- Stock Certificates

Legal Documents

- Food Stamps
- Postage Stamps (canceled or uncanceled)
- Checks or Drafts drawn by Government Agencies
- Internal Revenue Stamps (canceled or uncanceled)
- Passports
- Immigration Papers
- Motor Vehicle Licenses and Titles
- House and Property Titles and Deeds

General

- Identification Cards, Badges, or Insignias
- Copyrighted Works without permission of the copyright owner

In addition, it is prohibited under any circumstances to copy domestic or foreign currencies or Works of Art without permission of the copyright owner.

When in doubt about the nature of a document, consult with legal counsel.

Chapter 2

Getting to Know Your Copier

1. Typical Copies You Can Make with Your Copier

Typical copies you can make with your copier

Here's a sample of the features the copier is equipped with to turn out different types of copies. For the specific operations, see the relevant pages indicated by p.

Original Copy p. 3-35

1-sided 1-sided



1155O004AA

1-sided 2-sided

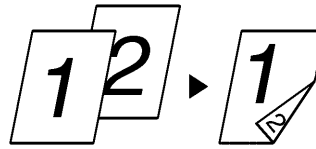

1155O006AA

2-sided 1-sided

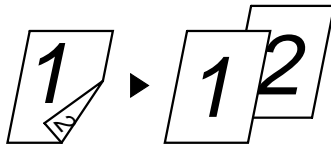

1155O726AA

Book 1-sided

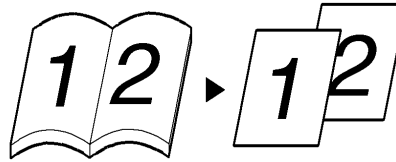

1155O005AA

2-in-1

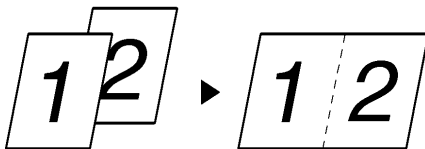

1155O007AA

4-in-1

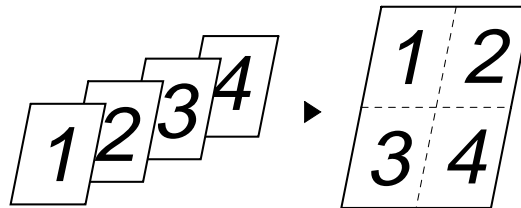

1155O725AB

Booklet

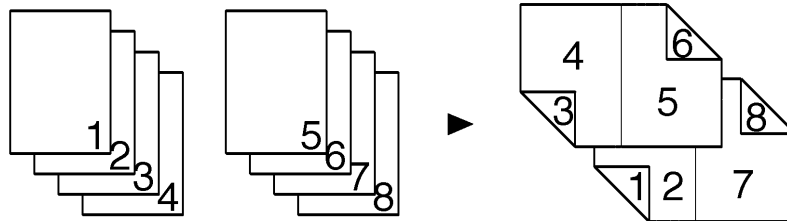

1155O008AA

Finishing ↗ p. 3-20

Sort

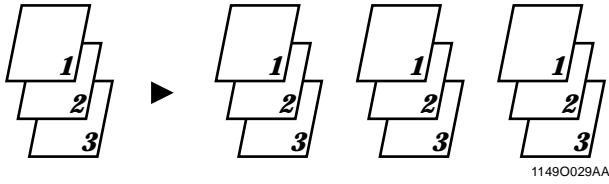

Staple

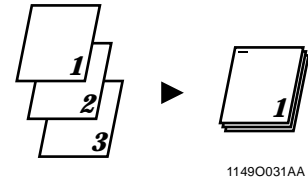

Group

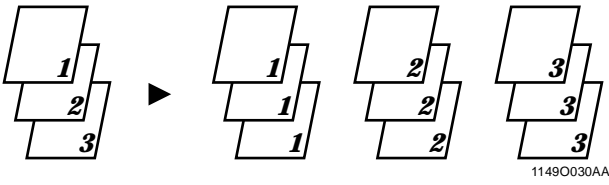

Hole Punch

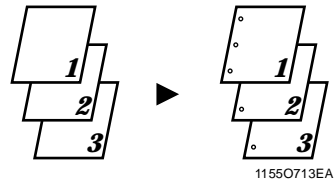

Folding Options

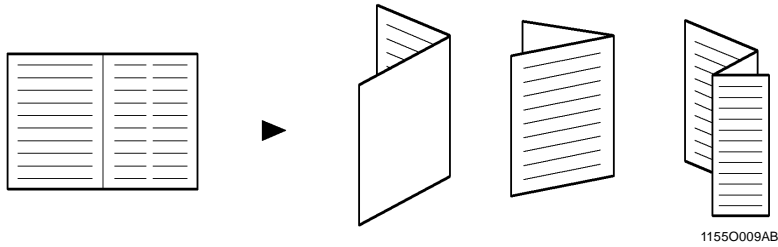

Zoom Ratio ↗ p. 3-14

Reduce, Full size, Enlarge, X/Y Zoom

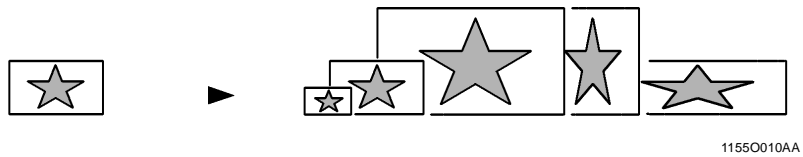

1. Typical Copies You Can Make with Your Copier

Auxiliary Functions

Cover ☞ p. 3-45

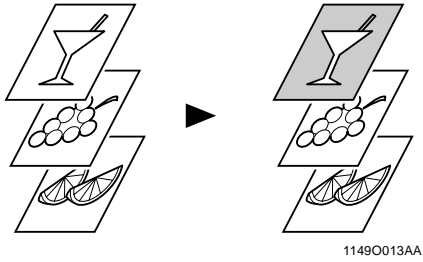

Page Insertion ☞ p. 3-47

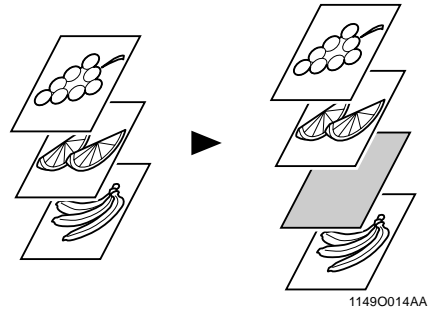

OHP Interleaving ☞ p. 3-51

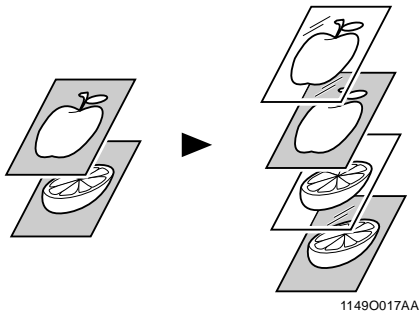

File Margin ☞ p. 3-55

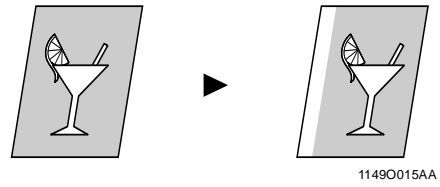

Erase ☞ p. 3-57

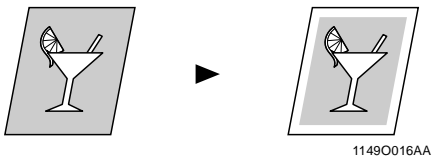

Number Stamping (Date) ☞ p. 3-61

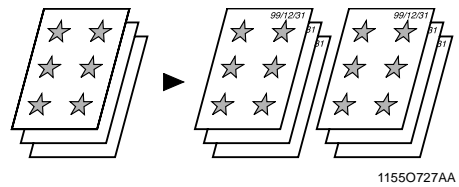

Number Stamping (Page) ☞ p. 3-61

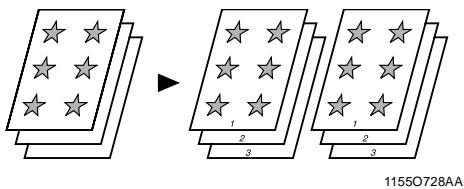

Number Stamping (Distribution) ☞ p. 3-61

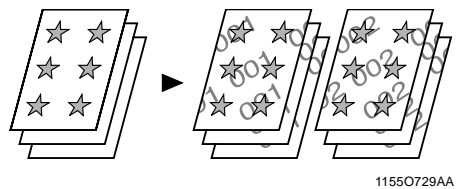

Auxiliary Functions

Image Repeat ↗ p. 3-59

Image Stamping ↗ p. 3-65



1155O051AA

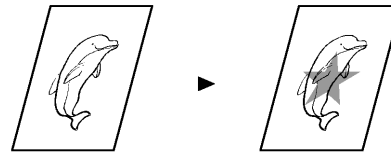

1155O011AA

Mixed Original Detection ↗ p. 3-67

Mixed Orig. Detection

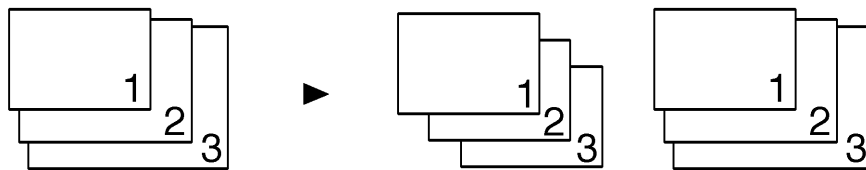

1155O003AA

2. System Overview

System Overview

The following overview presents the copier and the available options with a brief explanation of the function of each. Refer to “Control Panel Keys and Indicators” (p. 2-14) for using the Touch Panel and Control Panel.

Chapter 2

Getting to Know Your Copier

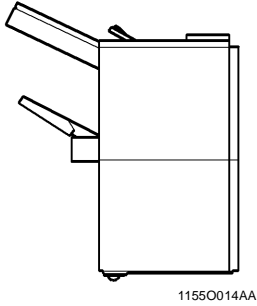

Finisher FN-3 <Option>
Permits sorting, grouping, sort-stapling, punching or folding copies.

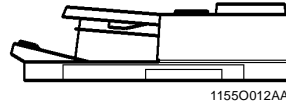

Electronic Document Handler EDH-1
In addition to being capable of feeding in sheet originals one at a time, it can automatically turn over the original for making copies from 2-sided originals.

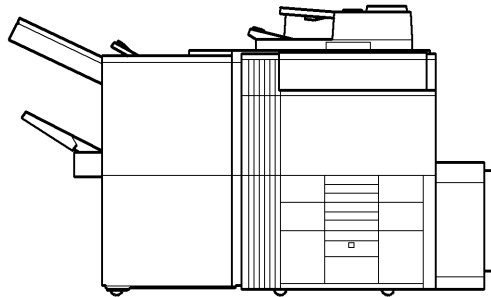

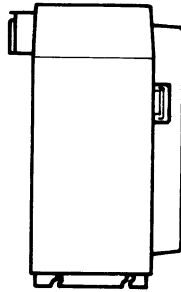

11340005AA

Large Capacity Cassette C-304 <Option>
Holds up to 3,400 sheets of LetterC copy paper (20 lbs.).

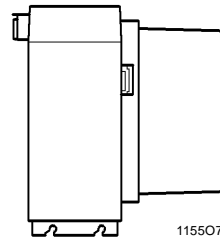

11550721AA

Large Capacity Cassette C-304L <Option>
Holds up to 3,400 sheets of LegalL, LetterL or LetterC copy paper (20 lbs.).

**16MB Memory
Hard Disk Drive Kit
<Option>**

Expands the memory capacity.

**Printer Controller <Option>
Interface Kit**

When the copier is fitted with this unit, it can function also as a printer.

* An Interface Kit is required for this connection.

* For more details, see the Printer Operator's Manual.

3. Copier Parts and Accessories

Outside the copier

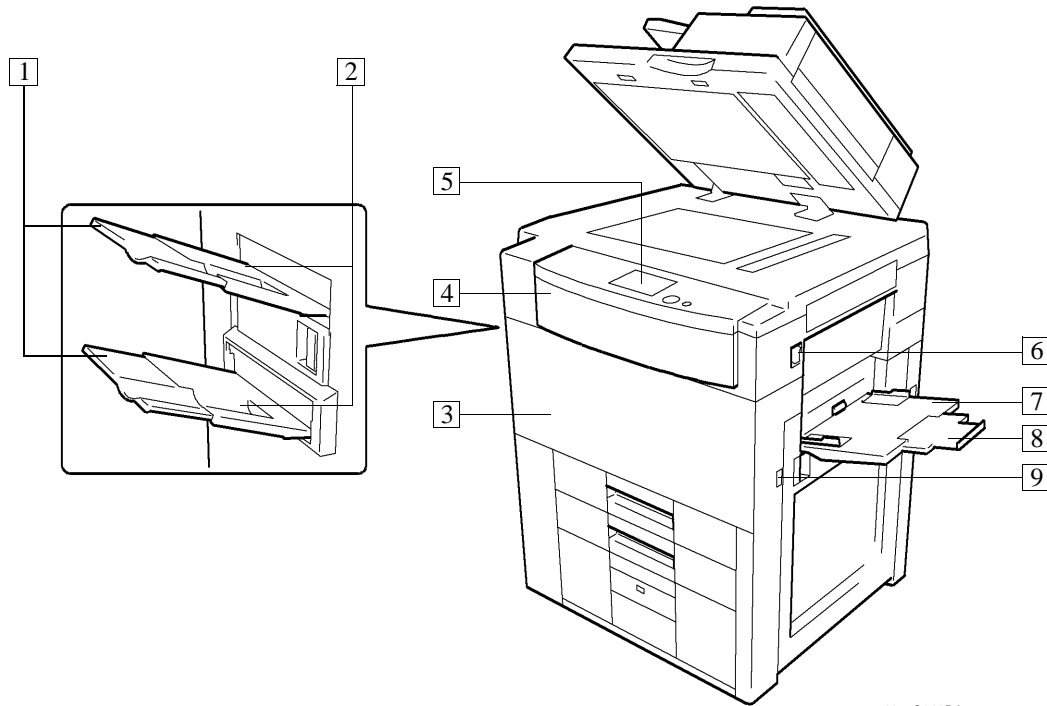

11550016DA

Copier

- | | | |
|---|-------------------------------|--|
| 1 | Exit Tray Extender | : Slide this extender out when making copies on large-size paper. |
| 2 | Exit Tray | : Holds copies fed out of the copier. (Option) |
| 3 | Front Door | : Open to clear a paper misfeed. ☞p. 5-12
Closing the Front Door after a misfeed has been cleared will turn the misfeed warning message on the control panel OFF. |
| 4 | Upper Front Door | : Open to replace the Toner Bottle. ☞p. 5-6 |
| 5 | Control Panel | : Use to start a copy cycle or to make copy job settings.
(See) Control Panel Keys and Touch Panel. ☞p. 2-14 |
| 6 | Power Switch | : Use to turn the copier ON and OFF. ☞p. 2-18 |
| 7 | Intelligent Multi Bypass Tray | : Use for manual feeding of copy paper into the copier. ☞p. 3-11 |
| 8 | Extender | : Slide this extender out to make copies on large-size copy paper. |
| 9 | Total Counter | : Shows the total number of copies made so far. |

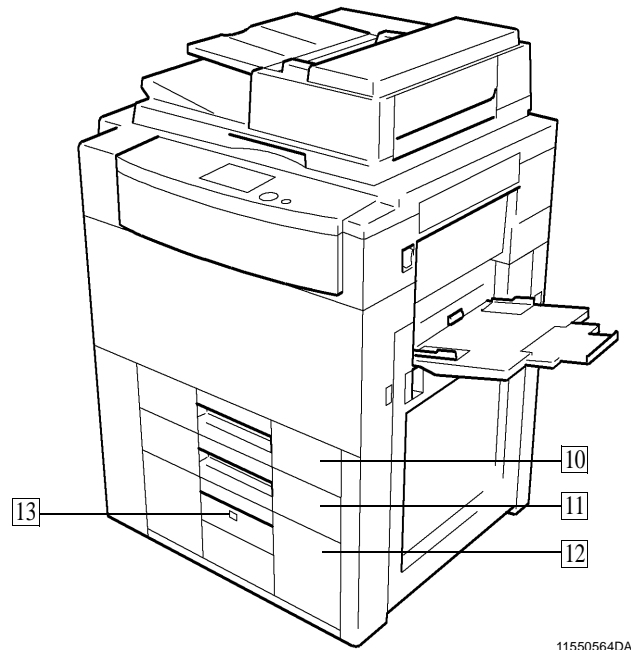

Drawers of the Copier

- | | | |
|-----------|-------------------|---|
| 10 | 1st Drawer | : Holds up to 550 sheets of copy paper. ↗p. 5-2 |
| 11 | 2nd Drawer | : Holds up to 550 sheets of copy paper. ↗p. 5-3
It can accommodate paper of different sizes. |
| 12 | 3rd Drawer | : Holds up to 2,700 sheets of copy paper. ↗p. 5-4 |
| 13 | Paper Descent Key | : Press before sliding the drawer out of the copier. |

Copier Accessories

Chapter 2

Getting to Know Your Copier

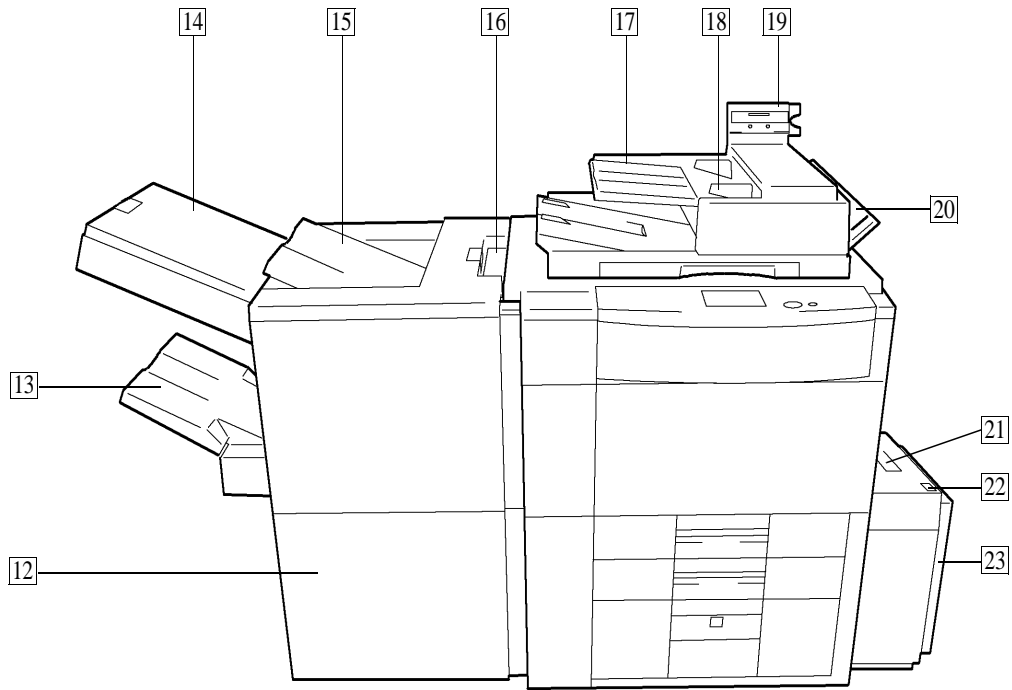

1155O019DA

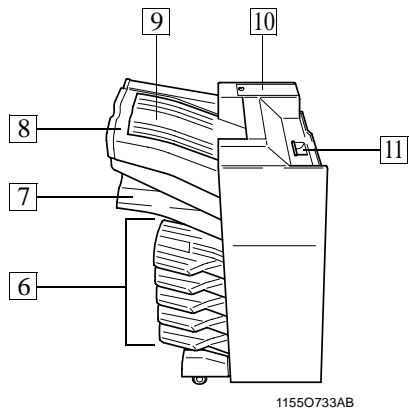

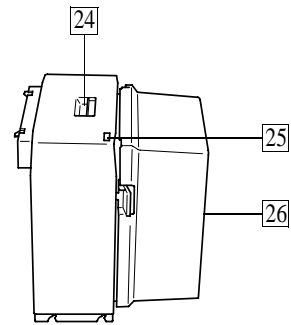

1155O733AB

For 62ppm only



1155O734AB

Finisher FN-3

- 12 Finisher Door : Open to replace the Staple Cartridge.  p. 5-8
Open to clear a paper misfeed.  p. 5-12
- 13 Bottom Offset Tray : Receives sorted/stapled copy sets or grouped copy stacks.
- 14 Manual Staple Tray Cover : Open to load documents for manual stapling or to clear a paper misfeed.
- 15 Top Offset Tray : Receives sorted copy sets or grouped copy stacks.
- 16 Grip : Grasp and press here to slide the Finisher away from the copier to clear a misfeed or other service job.

Precautions When Using a Finisher

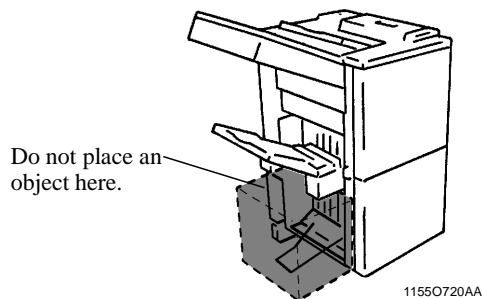

NEVER place an object under the Bottom Offset Tray or Elevator Tray. Anything that is placed under the Bottom Offset Tray or Elevator Tray can interfere with the tray when it lowers after a copy set has been fed onto it, which results in a malfunction.

3. Copier Parts and Accessories

Electronic Document Handler

- 17 Document Handling Tray : Load the originals face up on this tray. ☞p. 3-5
- 18 Document Guide Plate : Slide the plate as necessary to the size of the originals. ☞p. 3-5
- 20 Single Feed Tray : Insert a single sheet of original into the tray to make a copy or copies of it. ☞p. 3-8

Large Capacity Cassette C-304

- 21 Lock Release Lever : Use to unlock the Cassette from the copier for clearing a misfed sheet of paper or other service job.
- 22 Paper Plate Descent Key : Press to lower the paper plate.
- 23 Cassette Door : Open to add paper or clear a misfed sheet of paper.

Large Capacity Cassette C-304L

- 24 Lock Release Lever : Use to unlock the Cassette from the copier for clearing a misfed sheet of paper or other service job.
- 25 Paper Plate Descent Key : Press to lower the paper plate.
- 26 Cassette Door : Open to add paper or clear a misfed sheet of paper.

Inside the Copier

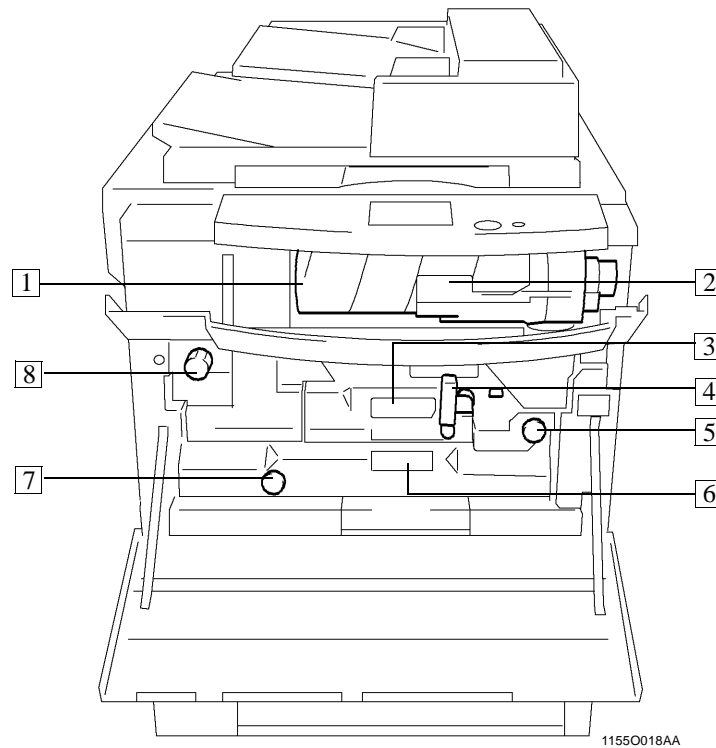

- | | | |
|---|--------------------------------------|---|
| 1 | Toner Bottle | : Contains Toner. Replace it with a new one when the warning message tells you to. ☞ p. 5-6 |
| 2 | Toner Bottle Holder | : Swing open to replace the Toner Bottle. ☞ p. 5-6 |
| 3 | Misfeed Removal Guide Unit M5 | : Use to clear a misfed sheet of paper. ☞ p. 5-14 |
| 4 | Misfeed Removal Lever M4 | : Press down to pull out the M5 Unit. ☞ p. 5-14 |
| 5 | Misfeed Removal Knob M3 | : Use to clear a misfed sheet of paper. ☞ p. 5-14 |
| 6 | Duplex Unit D2 | : Slide out to clear a sheet of paper misfed in the Duplex Unit. ☞ p. 5-16 |
| 7 | Misfeed Removal Knob D1 | : Use to clear a misfed sheet of paper. ☞ p. 5-14 |
| 8 | Misfeed Removal Knob M1 | : Turn to clear a misfed sheet of paper. ☞ p. 5-14 |

4. Control Panel Keys and Indicators

Control panel keys and indicators

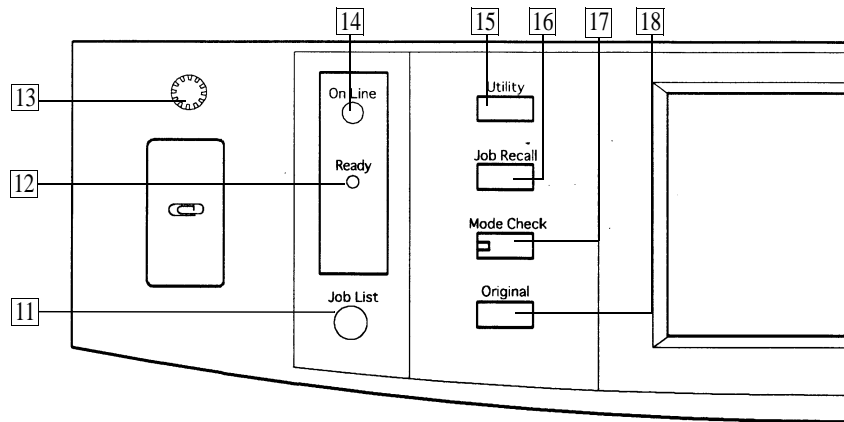

1 Touch Panel

- Shows various screens and messages.
☞ p. 2-16

2 Start Key

- Press to start the document scanning sequence.
- Press to start a print cycle.
- Lights up green to accept a print command; lights up orange to reject one.
- Print lamp :
Lights up to indicate that a print cycle can be run.
- Scanlamp:
Lights up to indicate that a document scanning cycle can be run.

3 10-Key Pad

Use to enter :

- The number of copies to be made.
- The various numeric values.

4 Clear Key

Press to:

- Reset the multi-copy entry to 1.
- Clear a zoom ratio entered when setting one from the 10-Key Pad.
- Clear the original count, image data scanned, and Access code.

5 Stop Key

Press to :

- Stop a print cycle.
- Stop a scanning cycle.

6 Access Mode Key

- Press to enter the access number. ☞ p. 2-20
* This key becomes valid only when Copy Track of the Administrator mode available from User's Choice is set.

7 Energy Saver Key

- Press to set the copier into the Energy Saver mode. ☞ p. 2-19

8 HDD Lamp

- Lights up to indicate that the Hard Disk Drive Kit (option) is being accessed.

9 Interrupt Key

- Press to interrupt a current job with a different one.
- Press it again to return to the previous job.
☞ p. 2-20
- Press to stop a multi copy cycle (except when the copier is in an interrupt mode).
- Lights up to indicate that the copier is in the Interrupt mode.

10 Panel Reset Key

- Press to set the copier into the initial mode, clearing all settings made on the control panel.
☞ p. 2-19
* It does not, however, clear the contents of the zoom and job program memory, Interrupt mode, and the job held in reserve.

4. Control Panel Keys and Indicators

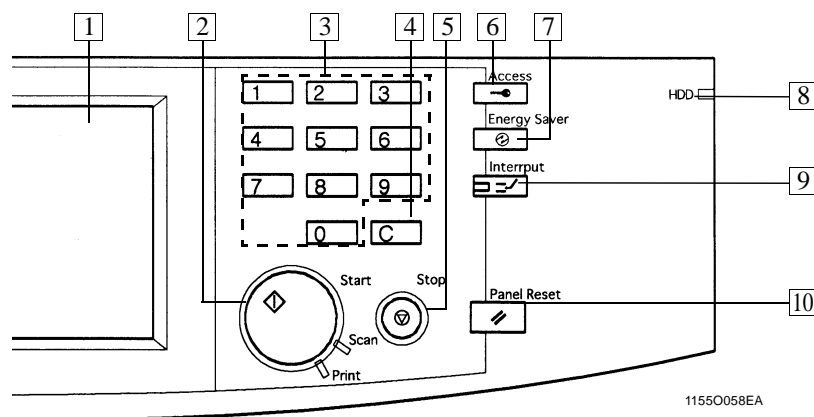
**11 Job List Key**

- Press to check for the settings made for a job (Mode Check), modify the settings of a job (Change), delete a job (Delete), and unlock a job (Unlock). *☞* p. 3-73
- Press to check for the memory space still available for use.
- When the lamp is lit up, it indicates that a job has been reserved.

12 Ready Lamp

- When the lamp is lit up, it indicates that data can be transferred.
- The lamp also indicates whether the copier is hooked up to the Printer Controller.
Blinking: Data is being transferred.
* For more details, see the Printer Operator's Manual.

13 Display Contrast Knob

- Turn to vary the brightness of the Touch Panel.

14 On Line Key

- Used when the copier is hooked up to the Printer Controller.

15 Utility Key

- Press to show the Utility Mode menu.

Utility Mode

- Job/Zoom Mem. Input •Meter Count
- User's Choice •Toner Replenisher

* For details, see Using the Utility Mode

☞ p. 4-1

16 Job Recall Key

- Press to show the Job Recall screen on which you can recall or check a copy-job program previously stored in memory.
- This key is not valid while the copier is in the Interrupt mode.
* For details, see Recalling a Job from Memory *☞* p. 4-5

17 Mode Check Key

- Press to show the Mode Check screen. From this screen you can access the setting screen of a particular function and change or cancel the setting as necessary.
- When the lamp is lit up, it indicates that the copying function currently valid is not the default setting.
* For details, see Mode Check *☞* p. 2-20

18 Original Key

- Press to select the Mixed Orig. Detection and other document-related functions setting screen.
 - Mixed Orig. Detection •Free Orig. Placement
 - Small Orig. Adjustment •Separate Scan

5. Using the Touch Panel

What is the Touch Panel?

When you turn ON the Power Switch, the Basics screen as shown below appears on the Touch Panel. It shows in messages and graphics the currently set functions, available functions to choose from, and the copier status.

* Some of the Touch Panel screens used in the Operator's Manual may be different from what you actually will see on your copier.

How the Screen is Organized

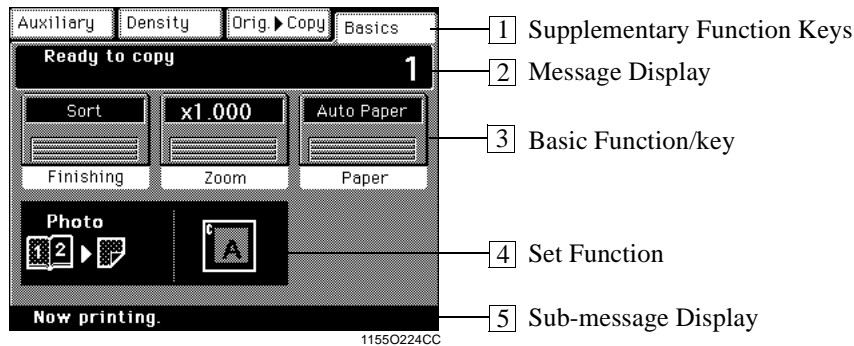

1 Supplementary Function Keys

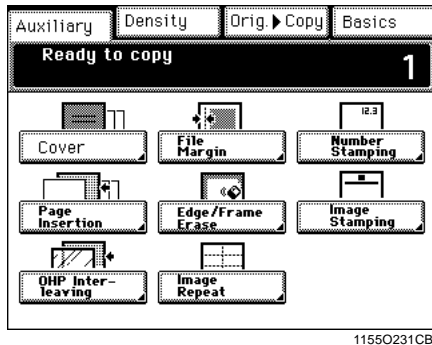

ex.) Auxiliary Function

The Auxiliary, Density, Orig, Copy, and Basics keys are displayed. When any of these keys is touched, the corresponding supplementary function screen appears.

*Touching Basic returns you to the Basics screen.

2 Supplementary Function Keys

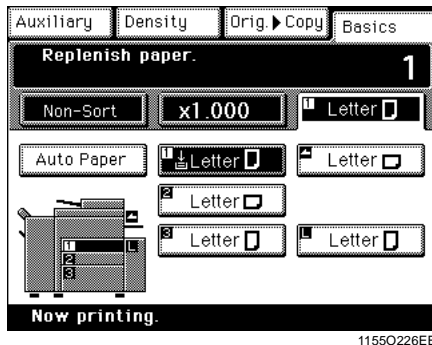

ex.) Add paper

Shows the current copier status, operating instructions and precautions, and other data including the number of copies selected.

3 Basic Function/Key Display

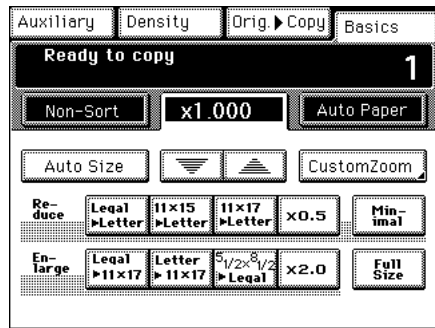

ex.) Zoom

1155O248EB

Shows the basic function keys and the corresponding functions currently selected for use. Touching a basic function key shows the corresponding basic function screen.

* What is shown inside the key is the current setting.

4 Set Function Display

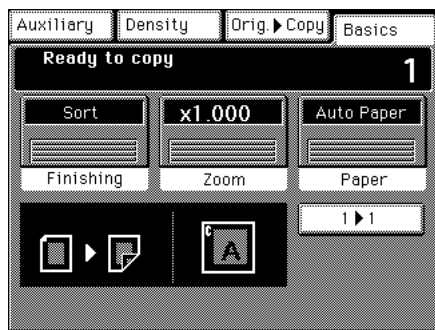

ex.) Orig. ► Copy : 1 ► 2
Finishing : Sort-and-Staple

1155O668CC

Shows graphic representations of the settings currently made for Orig. ► Copy and Finishing.

* When you want to check for more details of the set functions, press the Mode Check key.
☞ p. 2-20

5 Sub-message Display



ex.) Being printed

1155O224CC

Shows what is being done with the currently reserved job.

* To check for the settings made for the currently reserved job, press the Job List key. ☞ p. 3-73

Operating the Touch Panel

You need only to lightly touch the key shown on the Touch Panel to select or activate the function represented by the key.

NOTE

NEVER press the Touch Panel hard or use a hard or pointed object to press it, as a damaged panel could result.

6. Turning ON and OFF and Initial Mode

Turning ON and OFF

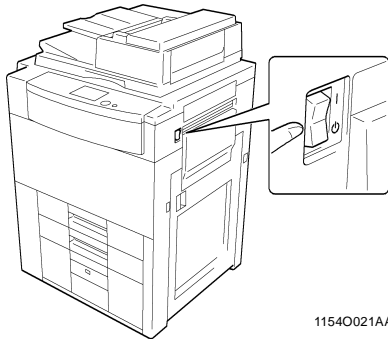

1154O021AA

- Turning the Copier ON:
Press the Power Switch to the **I** (ON) position.
- Turning the Copier OFF:
Press the Power Switch to the **⏻** (OFF) position.

NOTE

The Auto Power OFF function will automatically shut down the copier a given period of time after the last activity. ☞ p. 2-19

When the Copier is Turned ON

When the Power Switch is turned ON, the Start Key lights up orange.

In about a few seconds, the message “Now warming-up. Ready to scan.” appears and the Start key lights up green. The copier thereafter enables its auto copy start function. ☞ p. 2-19

At this time, however, pressing of the Start key does not start a copy cycle. The copier needs a warm-up period of about 7 minutes (at a room temperature of 23°C).

Initial Mode

When the Power Switch is turned ON, the Basic screen appears on the Touch Panel. The settings on this screen are called the initial mode, serving as the reference for all panel settings to be later made.



1155O228CB

No. of copies selected : 1
 Finishing : Non-Sort
 Zoom : ×1.000
 Paper : Auto Paper
 Density : Auto
 Orig. ▶ Copy : 1 ▶ 2

Touch this key if you want to make
 1 ▶ 1 copies.

Useful Tip

User's Choice can be used to change the settings of initial mode. ☞ p. 4-14

7. Auxiliary Functions

Auxiliary functions

Panel Resetting

The Panel Reset key resets all control panel settings to default settings including the number of copies and zoom ratio. The settings just made would also be cleared.

Useful Tips

- The Panel Reset key enables you to cancel all previous settings at the touch of the key.
- To avoid miscopy, try to press this key before making any setting for your own copy job.

Auto Panel Reset

If no key on the control panel is pressed within 1 min. after a copy cycle has been completed or copying settings made, the Auto Panel Reset function is activated to return the copier to the default settings.

Useful Tip

The time for the copier to enter the Auto Panel Reset Function can be selected from among “30 sec.,” “1 min.,” “2 min.,” “3 min.,” or “5 min.” For details, see *User's Choice*. ☞p. 4-18

Auto Copy Start

If you load originals into the document handler or place an original on the Glass and press the Start key while the copier is warming up after it has been turned ON, the Auto Copy Start function allows that copy process to be started as soon as the copier completes warming up.

Auto Shut OFF

The Auto Shut OFF function shuts down the copier a given period of time after the copier has been used last. The initial setting is 90 min.

Useful Tip

The time for the copier to enter the Auto Shut OFF mode can be selected from 15 to 240 min. The Auto Shut OFF function can even be disabled.

For details, see *User's Choice*. ☞p. 4-18

Energy Saver

If the copier is shut down when it is not in use, it takes the copier some time to complete the warm-up cycle. Instead of turning the copier OFF, it's a good idea to use the Energy Saver mode which will minimize the time for the copier to complete the warm-up cycle to about 20 sec.

To set the copier into the Energy Saver mode, you need only to press the Energy Saver key. Or, a given period of time after the copier has been touched last, it automatically enters the Energy Saver mode. The initial setting is 15 min.

To cancel the Energy Saver mode, press any key on the control panel.

NOTE

The copier is automatically shut down if the Auto Shut OFF function is activated while it is in the Energy Saver mode.

Useful Tip

The time for the copier to enter the Energy Saver mode can be selected from 1 to 240 min. For details, see *User's Choice*. ☞p. 4-18

7. Auxiliary Functions

Interrupt

The Interrupt function allows you to interrupt a current job and run a different one. Pressing the Interrupt key once sets the copier into the Interrupt mode. Pressing the key again lets the copier leave the Interrupt mode, returning to the previous settings.

NOTE

To cancel an Interrupt cycle, you need to press the Interrupt key. The Panel Reset key or Auto Panel Reset function does not serve this purpose.

Useful Tips

- Pressing the Interrupt key sets the copier into the initial mode, except for the finishing function which is Non-Sort.
- Custom Zoom and X/Y Zoom cannot be set in the Interrupt mode. Cover, Page Insertion, OHP Interleaving and Job Recall cannot be set in the Interrupt mode, either.

Mode Check

By pressing the Mode Check key on the control panel, you can either check for or change the current settings.

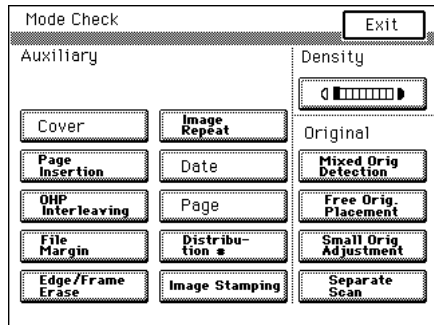

- When you touch **Exit** after having checked the currently set functions, the Basic screen reappears.
- To change a certain function, touch the corresponding key and then make the necessary change.

Access Number

If an access number has been programmed, it allows only particular persons to use the copier or a supervisor to keep track of the number of copies made by a particular department.

NOTES

- If an access number has been programmed, a copy cycle can be initiated only after the access number has been input to the copier. <“Access #” Prompt Screen>

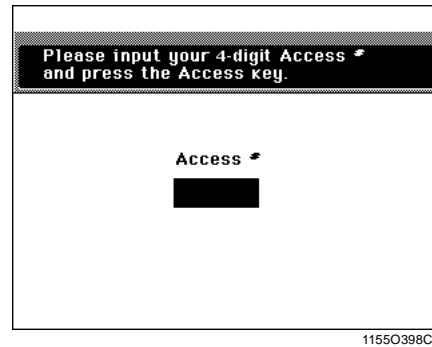

- Before you can use this function, you must first turn “ON” the “Copy Track” function of the Administrator Mode available from User’s Choice. *p. 4-19*

Entering the Access Number

- 1 From the 10-Key Pad, enter the 4-digit access number and press the Access Mode key.

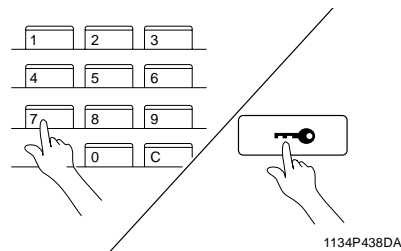

NOTE

To correct the 4-digit access number entered, first press the **C** key, then enter the new number.

- 2 When the initial screen reappears, you can now start the copy cycle.
- 3 When the copy cycle is completed, press the Access Mode key again.

Chapter 3

Making Copies

1. Basic Copying Overview

Basic Copying Overview

One of the most basic copying jobs is to make full-size (×1.000) copies of the original.

- Place the original in position (step 1), set the number of copies to be made (step 8), and press the Start key (step 9). This will allow you to make full-size copies on paper of the same size as the original. (*Automatically selected in the initial mode are Auto Paper, Full Size, and Auto Exposure.)

The selections → you make on the Touch Panel will change the exposure level, zoom ratio, the type of copy and so on.

1. Placing the Original

- Load the originals face up on the document handler. ☞ p. 3-4

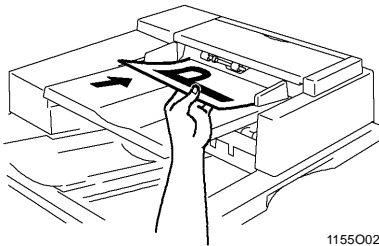

1155O023AA

- Raise the document handler and place the original face down on the Original Glass.

☞ p. 3-6

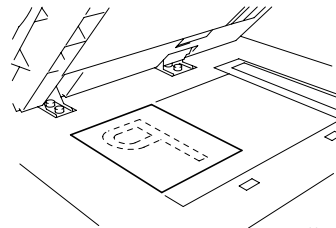

1155O773AA

To change the copy paper size

Selecting the basic functions

2. Touch **Paper** .
☞ p. 3-9

To change the zoom ratio

3. Touch **Zoom** .
☞ p. 3-14

- To sort copies
- To staple copies
- To punch holes in copies

4. Touch **Finishing** .
☞ p. 3-20

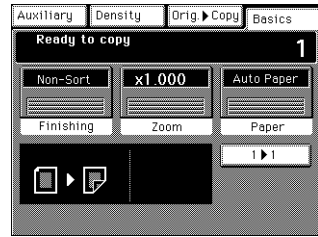

1155O228CB

- To make copies from a book
- To save copy paper

Selecting the original ► copy type

5. Touch **Orig. ► Copy** .
☞ p. 3-35

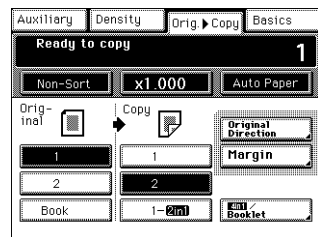

1155O229CB

- To change the exposure level

Selecting the exposure level

6. Touch **Density** .
☞ p. 3-43

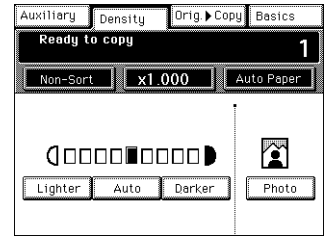

1155O230CB

- To make a file margin on the copy
- To use OHP Interleaving

Selecting the auxiliary functions

7. Touch **Auxiliary** .
☞ p. 3-45

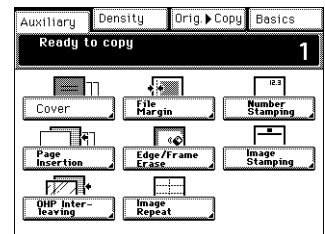

1155O231CB

8. Setting the number of copies.

- From the 10-Key Pad, set the desired number of copies to be made.

The maximum number that can be set is 999.

Useful Tip

The User's Choice can be used to limit the maximum number of copies to be set in the range from 1 to 99. ☞ p. 4-19

- * If you have entered an incorrect number, press the **C** key, then enter the correct number.

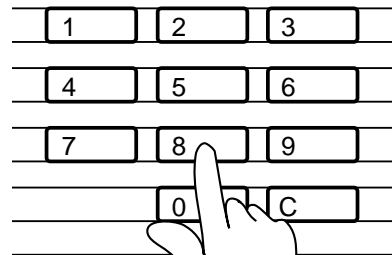

1139O2640A

9. Pressing the Start key

When you press the Start key, the copier starts the copy cycle.

- * To stop the copy cycle, press the Stop key.

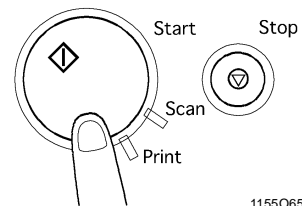

1155O651EA

Useful Tip

Different functions can be combined in various ways to create different types of copy. See "Typical Function Combinations" for how to combine the various functions offered by the copier. ☞ p. 3-75

2. Placing the Original

Using the Electronic Document Handler

The Document Handler automatically feeds in sheet originals placed on the Document Handling Tray one by one. After the copy cycle has been completed, it automatically ejects the original onto the Document Exit Tray.

Some originals may not be suitable for reliable operation in the Document Handler. Here is a guide.

Originals Suitable for the Document Handler

Types of Originals: Sheets (Plain paper)

Normal mode

- 1-sided Original (weighing 13-1/4 to 29-1/4 lbs.)
- 2-sided Original (weighing 16 to 24 lbs.)
- Mixed Original Detection mode (weighing 16 to 24 lbs.)

Original size: 1-Sided Original, 2-Sided Original Mode : 11"×17"L to 5-1/2"×8-1/2"L

Mixed Original Detection mode : 11"×17"L to Letter

Originals Not Suitable

- Typing paper, paraffin paper, and other thin paper
- Thick paper
- Originals greater than 11"×17"L or smaller than 5-1/2"×8-1/2"L
- Transparencies, translucent paper
- Wrinkled, dog-eared, curled, or torn originals
- Clipped or stapled originals
- Carbon-backed originals

* For any of these types of originals, place the original manually on the Original Glass to make a copy.

☞ p. 3-6

Loading the Originals

- 1 Slide the Document Guide Plate to the size of the originals.

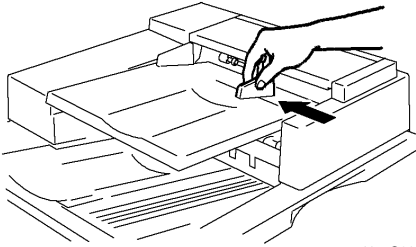

1155O022AA

- 2 Load a neat stack of originals face up on the Document Handling Tray.

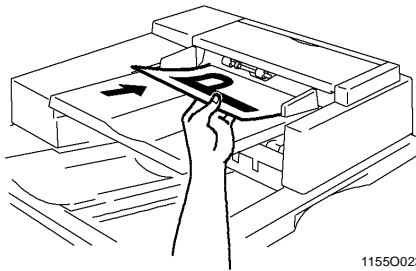

1155O023AA

NOTES

- The maximum number of originals that can be loaded: Up to 100.
- The copier is capable of scanning a document consisting of 100 or more pages at one time. ☞ p. 3-69
- Make sure that the top level of the original stack does not exceed the ▼ marking.
- Make sure that the Document Guide Plate is in touch with the edges of the original stack. If it's not pressed snugly against the original stack, skewed feeding could result.
- You can make copies automatically from originals of assorted sizes loaded in the Document Handler. You can also make copies of the same size from originals of different sizes. ☞ p. 3-67
- Load the original in the direction shown below when loading it in the Document Handler.

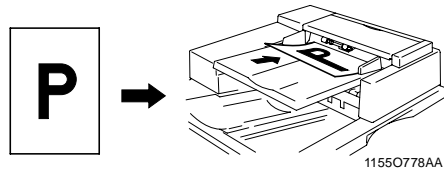

1155O778AA

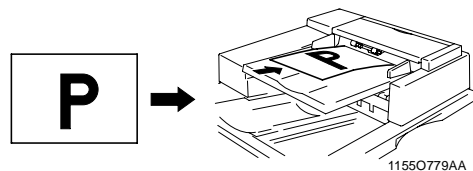

1155O779AA

- If you need to load your original in a direction different from these examples, set the direction of the original on the Touch Panel. ☞ p. 3-37

2. Placing the Original

Not Using the Document Handler

Different methods are used to place the original depending on its type. Use the procedure appropriate for your original. If you are using a Document Handler, see p. 3-4

- If you place your original directly on the Original Glass, make sure that it is placed in the direction illustrated below.

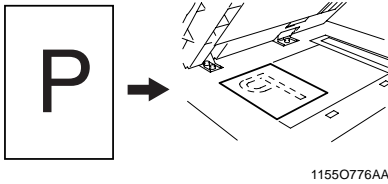

1155O776AA

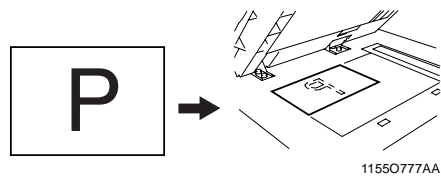

1155O777AA

- If you need to place your original in a direction different from these examples, set the direction of the original on the Touch Panel. see p. 3-37.

Sheet Originals

<Using plain paper or originals not suitable for the Document Handler>

- 1 Raise the Document Handler.
- 2 Place the original face down on the Original Glass.

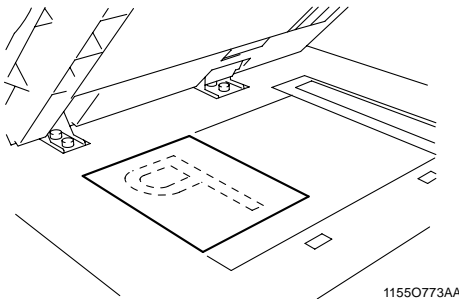

1155O773AA

- 3 Position the original in the left rear corner with the ↑ marker on the scale.

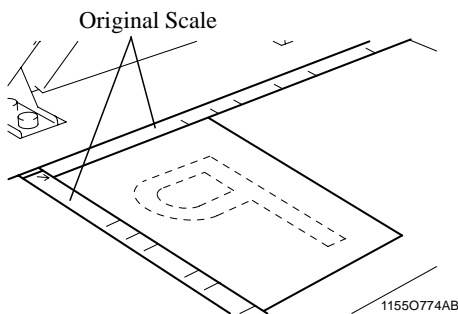

1155O774AB

- 4 Gently lower the Document Handler.

Highly Transparent Originals

<Using transparencies and translucent paper for the original>

- 1 Place the original in the same way as the sheet originals.
- 2 Place a blank sheet of paper of the same size over the original.

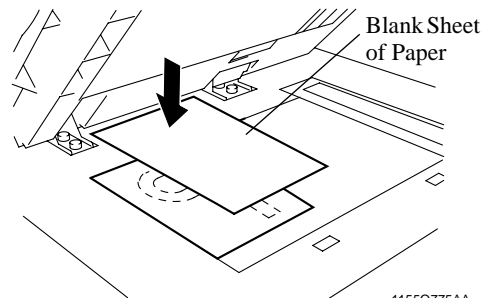

1155O775AA

- 3 Gently lower the Document Handler.

Making Copies from a Book Using Book Copy Mode

<“Book” refers to an open bound original>

- 1 Place the open book so that its top edge is at the rear of the copier and the center of the book is aligned with the Book Marker indicated on the Original Length Scale.

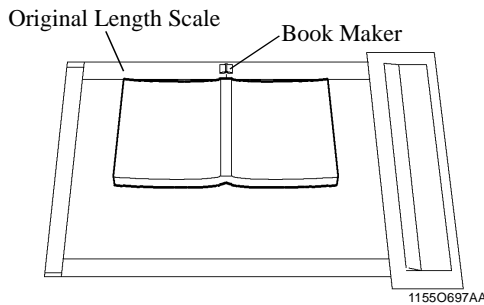
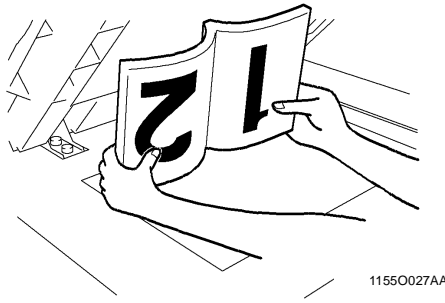

- 2 Gently lower the Document Handler.

NOTES

- If the book is thick, make a copy with the document handler raised.
- Not positioning the open book properly will result in copies with pages in incorrect order.
- Do not look directly at the Original Glass surface as a strong beam of light is emitted.

NOTES

- Be sure to raise the document handler 15° or more before placing the original. If the document handler is raised to an angle less than 15°, the copier may fail to select the correct copy paper size or zoom ratio.

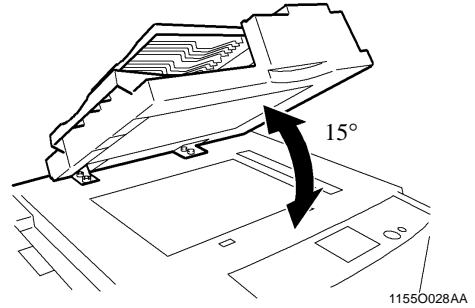

- Do not place an original weighing more than 6-1/2 lbs. on the Original Glass.
- When placing an open book, do not press the book hard on the Original Glass, as trouble could result.

2. Placing the Original

Using the SADF Mode

This is the mode in which you insert your originals one by one into the Document Handler to make a copy or copies from it. When you insert the original, the copier automatically starts the copy cycle.

NOTES

- *Originals appropriate for the SADF Mode.*

Type : Plain paper

Thickness : 9-1/4 to 41-3/4 lbs.

Size : 11"×17"L to 5-1/2"×8-1/2"L

- *The following features will be cancelled when using the SADF Mode.*

Auto Paper, Auto Zoom, Staple Mode, Punch Mode, Folding Options Mode, 2-sided Original Mode, Book, Dual Original Scanning Mode, 4-in-1 Mode, Booklet Creation, Cover Mode, Page Insertion Mode, OHP Interleaving Mode, File Margin Mode, Image Repeats, Mixed Orig. Detection and Free Orig. Placement.

- 1 Open the Single Feed Tray and slide the Guide Plate to the size of the original.

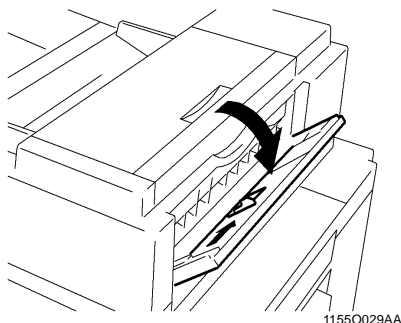

- 3 The original is automatically taken up and the copy cycle is started.

- 4 Making sure that the Scan Lamp and Print Lamp of the Start Key lights up green again, insert the next original.

- 2 Make sure that the Scan Lamp and Print Lamp of the Start Key are lit green and insert the original face down into the Tray.

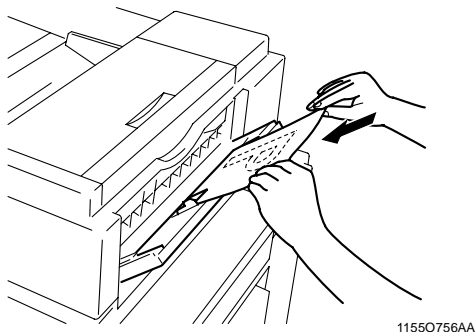

NOTES

- *Be sure to place one original at a time.*
- *Be sure to correct any fold or curl in the original beforehand.*

3. Selecting the Paper

In the following pages, we explain how to select the copy paper.

Touch **Basics** and **Paper** to show a screen which allows you to select the copy paper.

Copy Paper Size

Auto Paper

In the Auto Paper mode, the copier automatically selects the paper of the optimum size according to the size of the original being used and zoom ratio selected for use.

- 1 Touch **Paper** on the Basics screen and then touch **Auto Paper**.

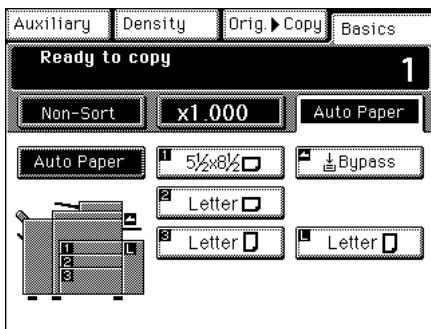

1155O232EB

NOTES

- The original sizes that can be detected in the Auto Paper Select Mode are 11"×17"L, LegalL, LetterL, LetterC, 5-1/2"×8-1/2"L, A4L, A4C. When making copies from originals other than the above, select the copy paper size.
- When using wrinkled or curled originals, the original size might not be detected correctly. So, select the copy paper size and do not use the Auto Paper Select Mode.
- When the document handler is used, the copier determines the copy paper size when the first original is taken up and fed in and uses that paper size for the subsequent originals (except in the Mixed Original Detection mode).

Useful Tips

- This mode is efficient when you want to make copies on paper of the same size as your originals automatically.
- Priority settings for the initial mode can be made using User's Choice.

Manual Selection

The copy paper size can be set manually according to your need.

- 1 Touch **Paper** on the Basics screen and the Touch Panel shows which drawer holds which copy paper size.

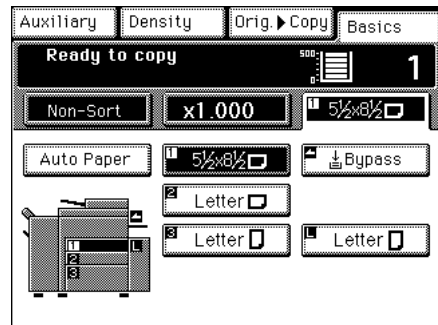

1155O234EC

- 2 Touch the desired paper size key.

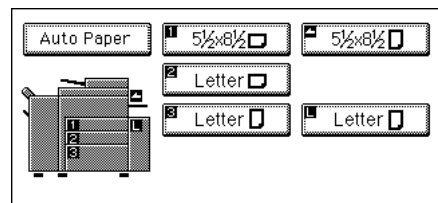





1155O236EA

- | | |
|---------------------|----------------------------------|
| 1 1st Drawer | ▲ Manual Bypass |
| 2 2nd Drawer | L Large Capacity Cassette |
| 3 3rd Drawer | |

3. Selecting the Paper

Special Paper Setting

If the symbol , , , , or  appears on the paper select key on the Touch Panel, it means that particular drawer has been designated for special paper.

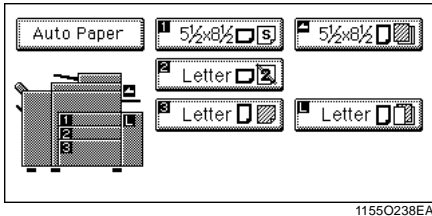

The copier provides five different types of special paper setting, each having a specific purpose as detailed below. The setting can be made by using User's Choice. [p. 4-18](#)

 : Recycled paper

This setting precludes the Auto Paper mode. You may be using both recycled as well as plain paper loaded in your copier. If, for example, you make this setting for the drawer loaded with recycled paper, the copier does not select that particular drawer in the Auto Paper mode. This allows you to make copies on plain paper first.

 : Disabling 2-sided copying

This setting precludes 2-sided copying.

 :Cover/Inserts

This setting precludes both Auto Paper mode and Automatic Drawer Switching. Make this setting for the paper for cover/inserts (e.g., colored paper), preventing that paper from being used for other purposes.

 :Cover

This setting precludes both Auto Paper mode and Automatic Drawer Switching. Make this setting for the paper for covers (e.g., colored paper), preventing that paper from being used for other purposes.

 :Inserts

This setting precludes both Auto Paper mode and Automatic Drawer Switching. Make this setting for the paper for inserts (e.g., colored paper), preventing that paper from being used for other purposes.

Auto Drawer Switching

If the drawer currently selected for use runs out of paper and there is another drawer loaded with paper of the same size and in the same direction, the copier automatically selects that second drawer to continue copying.

Useful Tip

This feature is a great advantage when you need to make a large number of copies on the same size paper. For example, you can make up to 3,850 copies without interruption if all three drawers and Multi Bypass Tray are loaded with paper of the same size and in the same direction. You can even make up to 7,250 copies if an optional Large Capacity Cassette is additionally fitted to the copier.

Manual Bypass Copying

- Use the Manual Bypass to make copies on paper not loaded in any drawer, or to copy onto OHP transparencies, thick paper, or any other special paper.
- When using the Multi Bypass Tray, you can load multiple sheets of copy paper.
- The setting of copy paper size is needed for manual bypass copying.
- Manual Bypass cannot be used for a reserved job.

Copy Paper that Can be Used for Manual Bypass

- ◆ Types of Paper
 - Plain paper (weighing 16 to 24 lbs.)
 - Thick paper (weighing 24-1/4 to 41-3/4 lbs.)
 - Recycled paper, OHP transparencies
- ◆ Paper Size
 - Max. Size : 11-3/4"×17"
 - Minimum Size: 4"× 5-3/4"
- ◆ Capacity of the Multi Bypass Tray
 - Plain paper, Recycled paper...Up to 50 sheets
 - Plain paper (once-copied paper)...Up to 20 sheets
 - Thick paper, OHP transparencies...Up to 20 sheets

Using the Intelligent Multi Bypass Tray

- 1 Place the original on the Original Glass and make the control panel settings.
- 2 Swing down the Bypass Tray and insert a neat stack of copy paper into the tray until it stops.
*Slide the Tray Extender out when using large-size copy paper.
- 3 Slide the Paper Guide Plate to the size of the copy paper.

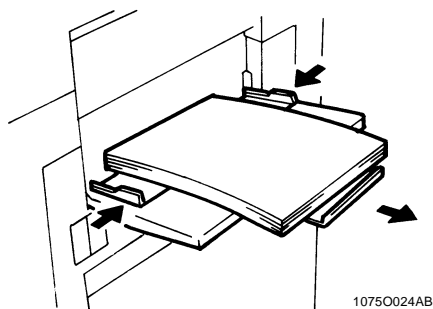
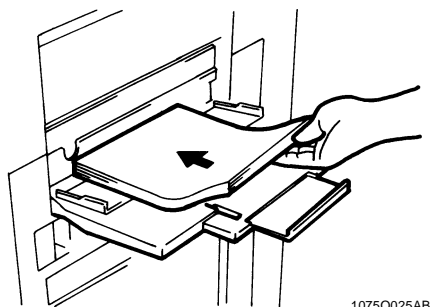

NOTES

- The paper should be loaded no higher than the ▼ (Max. Level Indicator).
- Before inserting, fan the paper stack well if you are using OHP transparencies.
- Correct any curl if you are using thick paper.
- For making copies on thick paper or OHP transparencies, the following functions cannot be used: 1 ► 2, Booklet Creation, Staple, Hole Punch, Folding Options.
- The paper will be copied on the side facing up.

3. Selecting the Paper

- 4 Select the desired copy paper size.

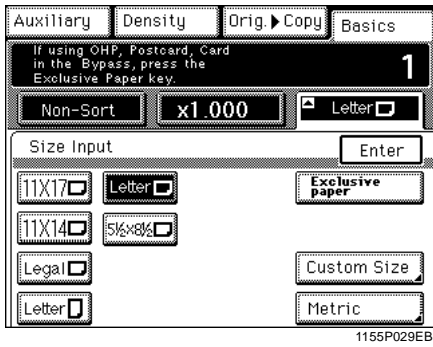

- 5 Touch **Enter**.

<Changing the Paper Size>

- Touch **Paper** and **Size Input** on the Touch Panel.

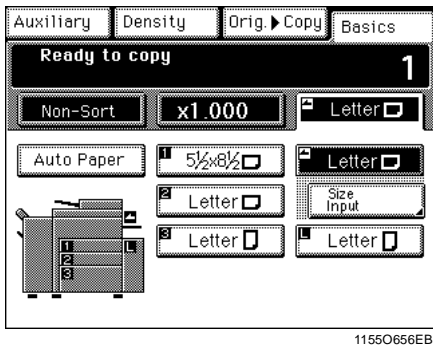

- Select the desired copy paper size.

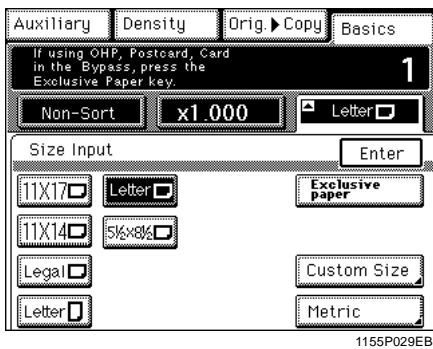

- Touch **Enter**.

<Using Metric Size Paper>

When you want to use metric size paper, touch **Metric** on the screen given in step 4 and you have a screen that allows you to select a metric paper size.

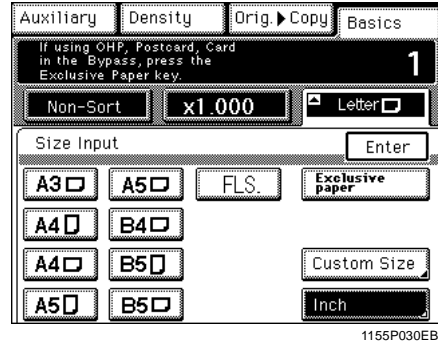

<Using Nonstandard Size Paper>

- When you use a nonstandard size paper, touch **Custom Size** on the screen given in step 4 and you have the following screen.

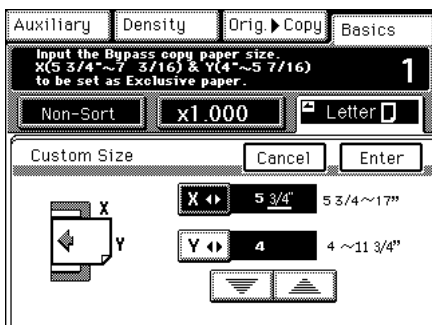

11550243EB

- Touch ∇ or \blacktriangle to set the whole number for X and touch the **X** key. The underline moves to the number and the **X** key. Now the value for X has been fixed.

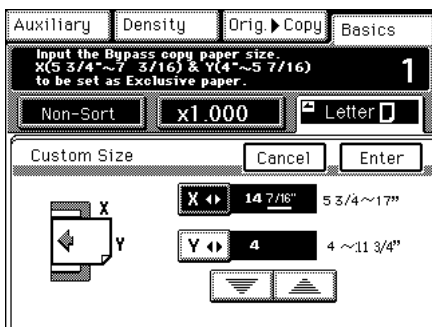

11550245EB

- Do the same for Y, then touch **Enter**.

<Using Exclusive Paper>

Exclusive Paper: Thick paper and OHP transparencies.

After a paper size has been selected in step 4, touch **Exclusive paper**.

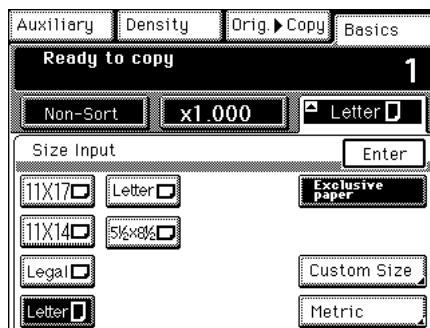

11550292EB

NOTES

- The Exclusive Paper mode is automatically selected when a length in the range of 5-3/4" ~7-3/16" is entered for X and a width in the range of 4" ~5-7/16" is entered for Y using Custom Size.
- When a multi-page document is copied using the Electronic Document Handler, the page order of the originals is reversed in the copy set.
- When making copies of a multi-page document through the Glass, start with the last page and go in descending order.

Useful Tips

- Exclusive Paper setting precludes 1 ► 2, Booklet Creation, Staple Mode, Punch Mode and Folding Options.
- This setting prevents that paper from being used for other purposes.
- This setting ensures that the copier uses the paper path for exclusive paper.

4. Selecting the Zoom

Zoom Ratio

In the following pages, we explain how to select the zoom ratio. When you touch **Zoom** after touching **Basics** on the Touch Panel, a screen appears that allows you to set the zoom ratio. You have six different ways to choose from to set the zoom ratio. Select one according to your need.

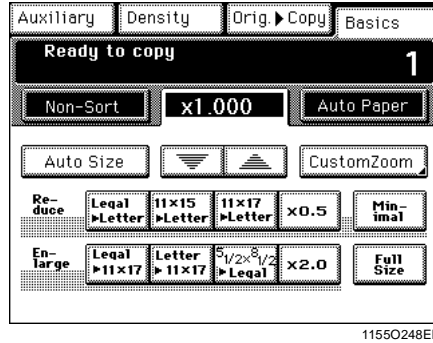

1155O248EB

Auto Size

In the Auto Size mode, the copier automatically selects the zoom ratio according to the size of the original being used and the copy paper size selected for use.

- 1 Touch **Auto Size** to set the copier into the Auto Size mode.

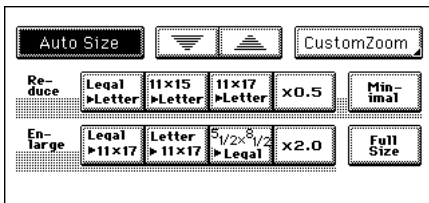

1155O250EA

- 2 Select the paper size.
(Copy Paper Size p. 3-9)

Useful Tips

- This mode is very helpful for neat filing when you need to make copies from originals of assorted sizes.
- Priority settings for the initial mode can be made using User's Choice.

Selecting the Fixed Zoom

The copier provides most frequently used zoom ratios ready for immediate use.

- 1 Touch the appropriate original-to-copy-size representation key. You have four reduction and four enlargement ratios.

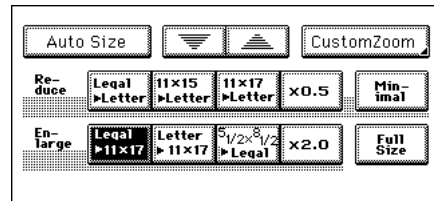

1155O252EA

When you touch **Full Size**, full size (×1.000) is selected.

NOTE

When the document handler is used, the copier determines the zoom ratio when the first original is taken up and fed in and uses that zoom ratio for the subsequent originals (except in the Mixed Original Detection mode.)

For a Slightly Smaller Image

This function lets you make a copy slightly reduced in image size from that of the original.

1 Touch **Minimal**.

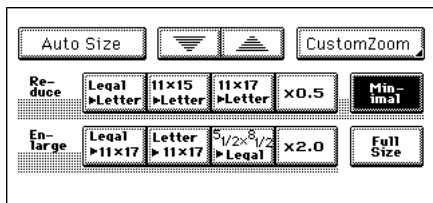



1155O254EA

Useful Tips

- A ratio of $\times 0.930$ has been factory-programmed in Minimal, but that ratio can be changed as necessary. *☞* p. 4-6
- It comes in handy for making a copy, without losing any portion of the original image, from an original which has an image area covering its entire surface.

Using Zoom Up/Down Keys

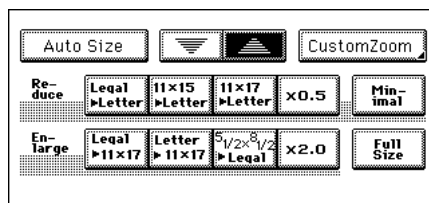

Pressing the  or  key changes the zoom ratio in 0.001 increments. You can hold down the key to change the ratio quickly.

1 Hold down the  or  key until the desired zoom ratio is reached.



1155O256EA

Useful Tips

- To save time, first select the fixed zoom ratio nearest to the target ratio before using the  or  key.
- The zoom ratio can be set within the range $\times 0.250$ to $\times 4.000$ when placing the original face down on the Original Glass. When using the Document Handler, the ratio can be set within $\times 0.250$ to $\times 2.000$.

4. Selecting the Zoom

Using the 10-Key Pad

You may use the 10-Key Pad to directly enter the zoom ratio.

<Same ratio for X and Y>

1 Touch **Custom Zoom**.

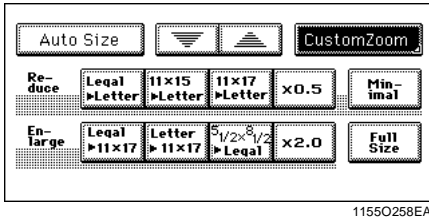

2 Enter the desired zoom ratio from the 10-Key Pad.

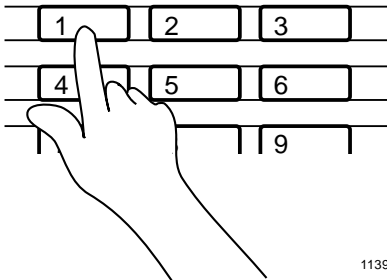

Useful Tips

Example: $\times 1.300$

Press 1, 3, 0, and 0, in that order.

$\times 1.300$

1149O160BA

- To correct a ratio, press the **C** key and then enter the correct one again.
- The zoom ratio can be set within the range $\times 0.250$ to $\times 4.000$ when placing the original face down on the Original Glass. When using the Document Handler, the ratio can be set within $\times 0.250$ to $\times 2.000$.

3 Touch **Enter**.

<Using the X / Y Zoom>

1 Touch **Custom Zoom**.

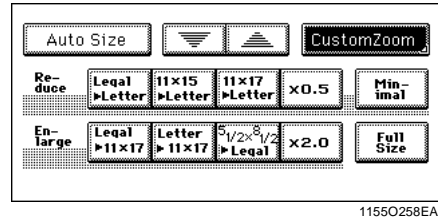

2 Touch **X / Y Zoom**.

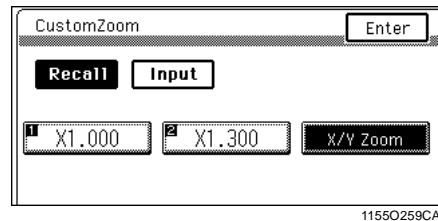

3 Touch **X** and enter the zoom ratio from the 10-Key Pad. Then do **Y**.

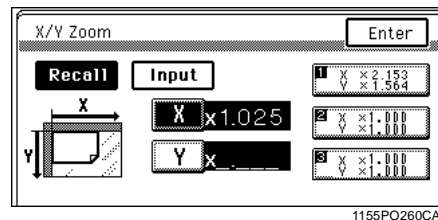

Useful Tips

- To correct a ratio, press the **C** key and then enter the correct one again.
- The zoom ratio can be set within the range $\times 0.250$ to $\times 4.000$ when placing the original face down on the Original Glass. When using the Document Handler, the ratio can be set within $\times 0.250$ to $\times 2.000$.

4 Touch **Enter**.

Calling up a Ratio from Memory

You can store some of the most frequently used zoom ratios in memory and recall them later as necessary.

<Same ratio for X and Y>

1 Touch **Custom Zoom**.

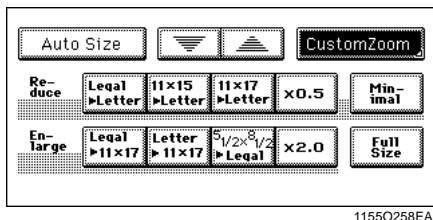

2 From among the two ratios previously stored in memory, select the desired one.

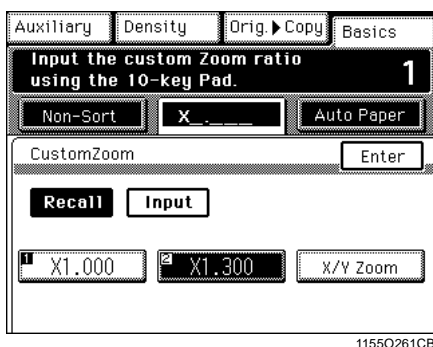

Useful Tip

It's a good idea for you to store frequently used zoom ratios in memory. ☞ p. 3-18

3 Touch **Enter**.

<Using the X/Y Zoom>

1 Touch **Custom Zoom**.

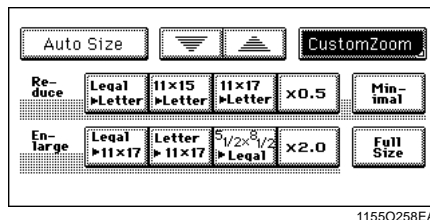

2 Touch **X / Y Zoom**.

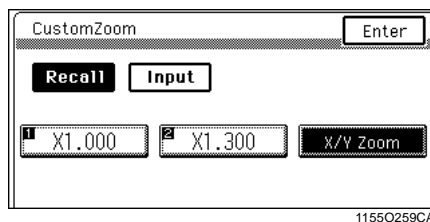

3 From among the three ratios previously stored in memory, select the desired one.

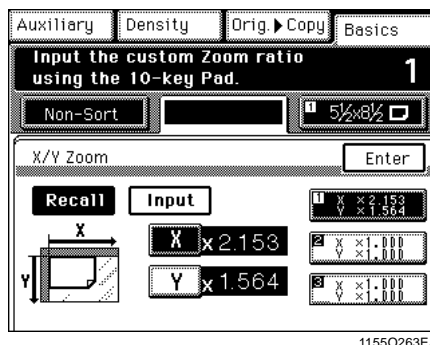

Useful Tip

It's a good idea for you to store frequently used zoom ratios in memory. ☞ p. 3-18

4 Touch **Enter**.

4. Selecting the Zoom

Storing a Ratio in Memory

<Same ratio for X and Y>

1 Touch **Custom Zoom**.

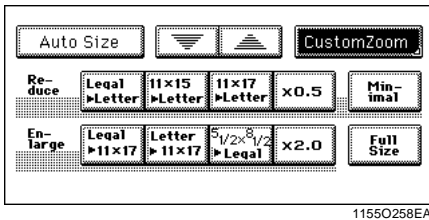

2 Touch **Input**.

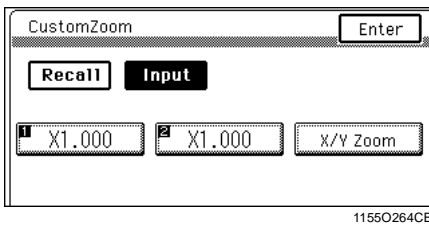

3 Enter the desired zoom ratio from the 10-Key Pad.

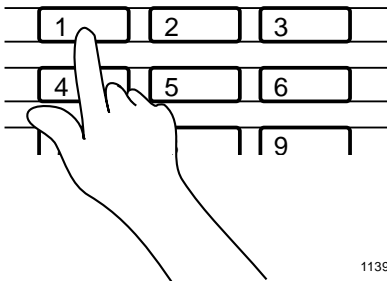

4 Touch memory location key **1** or **2** in which to store the set zoom ratio.

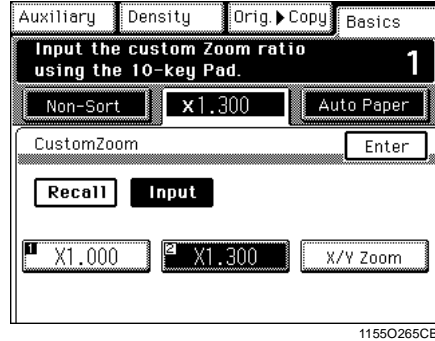

* When the key is touched, the ratio is shown on the key, indicating that it has been stored in memory.

NOTES

- When a new ratio is stored, the old one is erased.
- The ratios may also be stored in memory by using the Utility Mode. ☞ p. 4-6

5 Touch **Enter**.

Useful Tips

Example: $\times 1.300$

Press 1, 3, 0, and 0, in that order.



- To correct a ratio, press the **C** key and then enter the correct one again.
- The zoom ratio can be set within the range $\times 0.250$ to $\times 4.000$ when placing the original face down on the Original Glass. When using the Document Handler, the ratio can be set within $\times 0.250$ to $\times 2.000$.

<Using the X/Y Zoom>

- 1 Touch **Custom Zoom**.

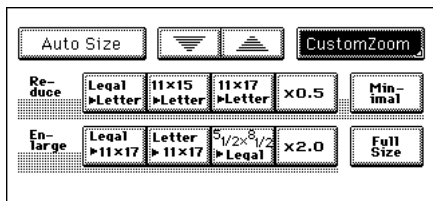

1155O258EA

- 2 Touch **X/Y Zoom**.

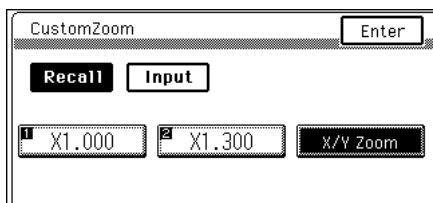

1155O259CA

- 3 Touch **Input**.

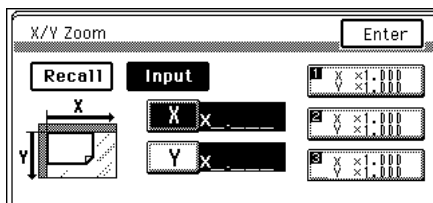

1155O266CA

- 4 Touch the **X** or **Y** key to enter the desired zoom ratio from the 10-key Pad.

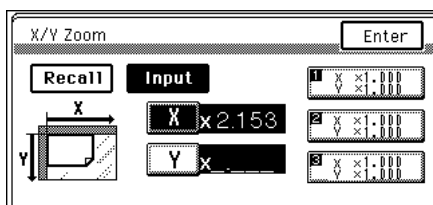

1155O269CA

- 5 Touch memory location key **1**, **2** or **3** in which to store the set zoom ratio.

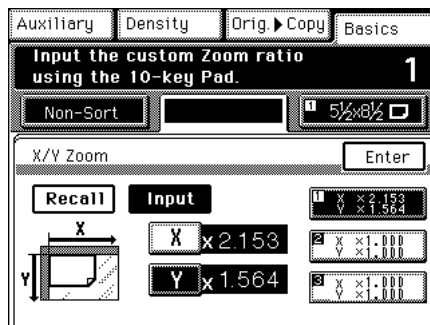

1155O268EB

* When the key is touched, the ratio is shown on the key, indicating that it has been stored in memory.

NOTE

When a new ratio is stored, the old one is erased.

- 6 Touch **Enter**.

5. Selecting the Finishing

In the following, we explain about different finishing functions and setting procedures.

When **Finishing** is touched on the Touch Panel, a screen appears that allows you to set a particular finishing function.

Finishing Functions

Non-Sort

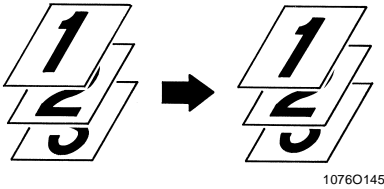

- All copies are fed out without being sorted, grouped, stapled or punched.
Touch **Non-Sort**.

NOTE

Thick paper and OHP transparencies cannot be used for making copies in Staple, Punch and Folding.

Sort

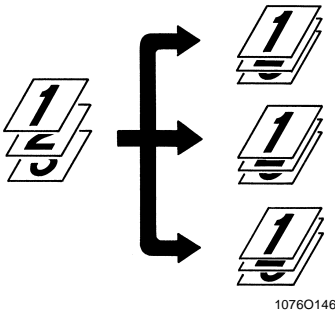

- This function is effective when making multiple copies from multiple originals. Copies are sorted into complete sets of the originals.
Touch **Sort**.

Group

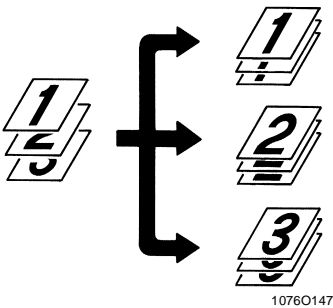

- The copies made from each original are separated into groups. Each group contains the same number of copies.
Touch **Group**.

Staple

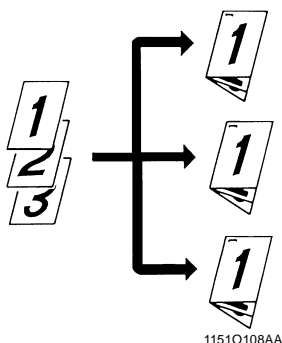

<Only when the Finisher or Mailbin Finisher is mounted>

- This function is effective when making multiple copies from multiple originals. Copies are sorted or grouped into complete sets of the originals and then stapled.
- Only when the Finisher FN-3 is mounted, this feature is efficient for stapling originals after making copies. ☞ p. 3-26
Touch **Staple**.

Folding



<Only when the Finisher FN-3 is mounted>

- This function allows you to fold copies.
Touch **Fold**.

* You have a choice of folding options, either Crease, Half-Fold or Z-fold. ☞ p. 3-28

Useful Tip

The copier has been factory-set to automatically select Non-Sort in the initial mode. Also, the copier automatically switches between Sort and Non-Sort depending on the number of originals loaded in the Document Handler and the number of copies to be made. User's Choice can, however, be used to change these default settings. ☞ p. 4-16

Selecting the Finishing Function

Sort/Group

1 Touch the desired finishing function key.

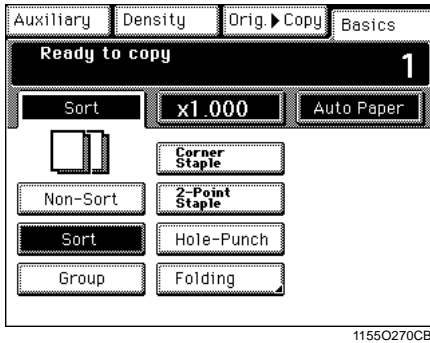

1155O270CB

NOTES

- Only when the Finisher FN-3 is mounted, copies are fed out in a crisscross manner.
- Crisscross sorting is possible only when all of the following conditions are met:
 - Crisscross Mode of User's Choice is turned ON.
 - The copier is loaded with paper of the same size, but in two different directions.
 - Mixed Original Detection is turned OFF.
 - None of the Staple, Hole Punch, Folding, Page Insertion, and Cover functions are set.

Useful Tips

- If Crisscross is set to ON in User's Choice, sorted copy sets will be stacked in a crisscross manner, one set stacked lengthwise on top of another set stacked crosswise. Otherwise, if Crisscross is set to OFF, the sorted copy sets will be stacked together in the same direction.
- The default setting for Crisscross is ON. This can be changed to OFF in User's Choice.
 - ☞ p.4-16

Useful Tips

- **Shift Sorting**
The sorted copy sets are stacked in the same direction, but in a sawtooth manner by shifting the tray to the front or rear for each set.



1166O033AB

- **Crisscross Sorting**
The sorted copy sets are stacked in a crisscross manner, one set stacked lengthwise on top of another set stacked crosswise.



1166O034AB

- **Shift Grouping**
The sorted copy stacks are stacked in the same direction, but in a sawtooth manner by shifting the tray to the front or rear for each stack.



1166O035AB

- **Crisscross Grouping**
The sorted copy stacks are stacked in a crisscross manner, one stack stacked lengthwise on top of another stack stacked crosswise.



1166O036AB

Hole Punch

- 1** Touch the desired finishing function key.
Touch **Hole Punch**.

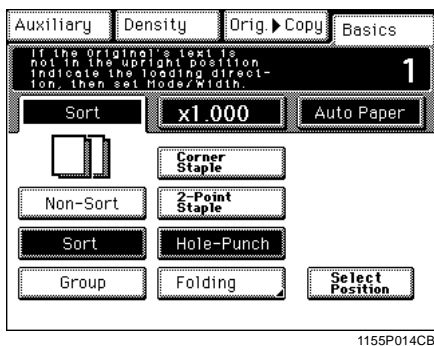

NOTES

- The size of the copy paper for Hole Punch is 11"×17"L, LegalL, LetterL and LetterC only.
- Hole Punch is not possible in the Interrupt mode.
- When making copies in the Hole Punch Mode, make sure to load the originals into the Document Handler in the correct direction.
p. 3-31

<Only when the Finisher FN-3 is mounted>

- The number of punch holes can be changed between "2-Hole" and "3-Hole" by using the Knob located inside the Finisher.
- *When changing the setting for the number of holes to be made, be sure the  marks are aligned.

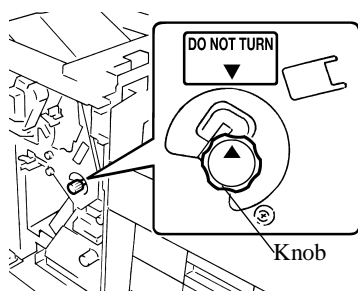

Pull out Knob: 2-Hole



Push in Knob: 3-Hole



*The number of punch holes can be graphically identified on the Display.

Useful Tips

- If you do not select a hole-punching position, the copier automatically sets the Hole Punch position according to the original feeding direction illustrated below.

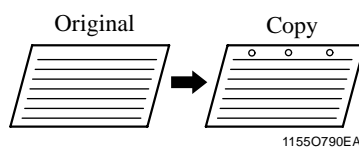
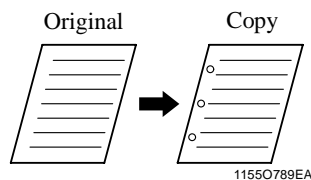

- When making copies from either the 11"×17" or LegalL size, the copier automatically specifies the hole punching position as shown below.

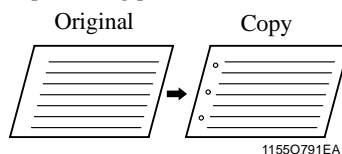

5. Selecting the Finishing

Select Position Key:

Use this key when you want to place your original in a direction other than the standard or make punch holes in positions other than those made automatically.

1 Touch **Select Position**.

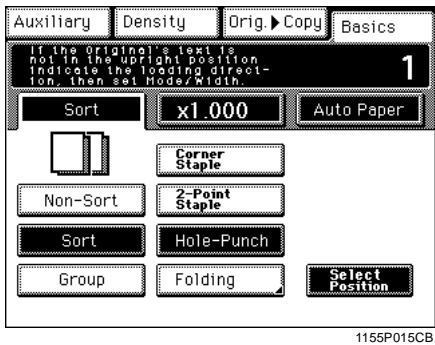

1155P015CB

2 Touch the desired hole-punching position.

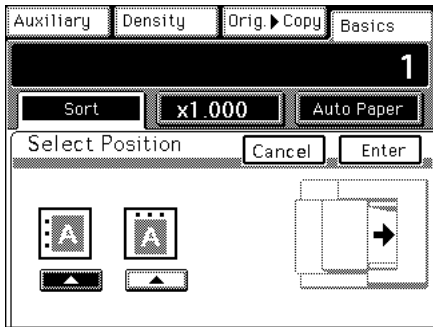

1155P026EB

3 Touch **Enter**.

Staple

<Only when the Finisher FN-3 is mounted>

1 Touch the desired finishing function key.

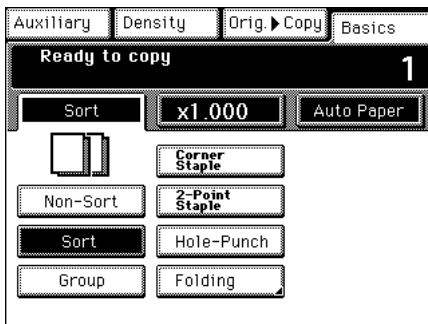

1155O270CB

2 Touch the stapling key of your choice.

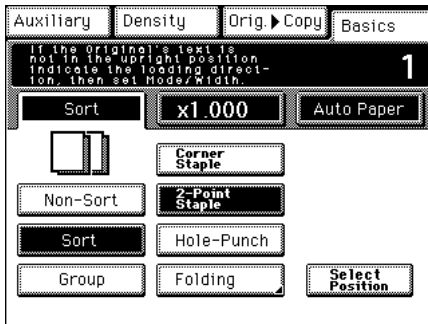

1155P016CB

You have a choice of the following two stapling types.

• Corner Staple

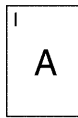

Paper size :
11"×17"L, LegalL,
LetterL, LetterC
Number of sheets :
2 ~ 50

• 2-Point Staple
<Side Staple>

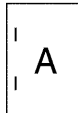

Paper size :
11"×17"L, LegalL,
LetterL, LetterC
Number of sheets :
2 ~ 50

<Center Staple>



Paper size :
11"×17"L, LetterL
Number of sheets :
2 ~ 15

1155O768EA

*When you touch a stapling key, the sorter is automatically set into the Sort mode.

3 Touch **Select Position**.

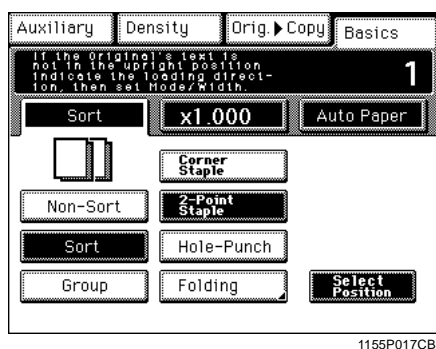

<Useful Tip

Paper size : 11"×17L" to Letter

Number of sheets : 2 to 50

Kinds of Paper: Plain paper, Recycled paper

NOTES

- The stapling position cannot be specified if Corner Staple is selected.
- Although Hole Punch is combined with Corner Staple, you can specify the stapling position.

4 Touch the desired stapling position on the Touch Panel.

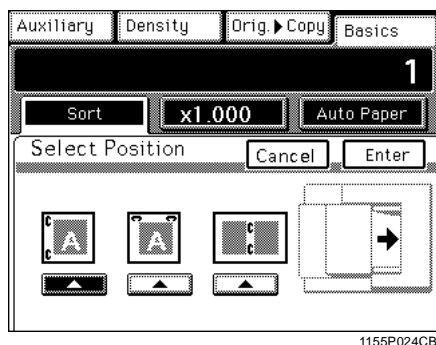

5 Touch **Enter**.

NOTES

- Stapling is not possible in the Interrupt mode.
- Note the correct direction of the originals when making copies in the Sort Staple Mode.

☞ p. 3-32

5. Selecting the Finishing

Manual Staple

- 1** Open the Manual Staple Tray Cover.

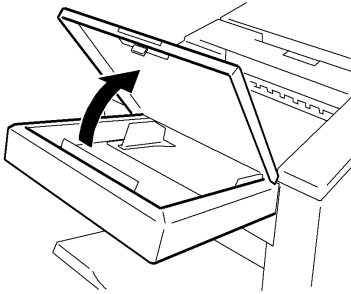

1155O033AA

- 2** Align the sheets of paper neatly.

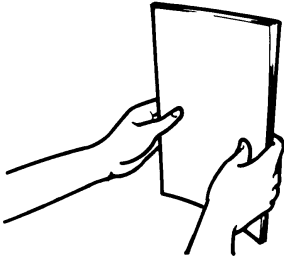

1134O039AA

- 3** Insert a neat stack of papers face down into the Staple Tray.

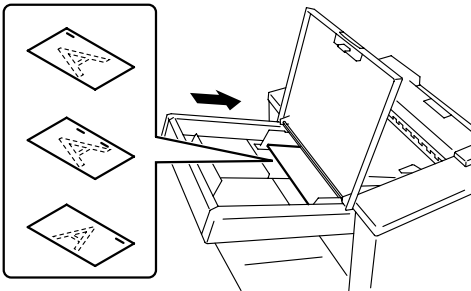

1155O036AB

NOTES

- Make sure of the stapling position and press the paper stack against the end bracket.
- Up to 50 sheets of plain paper can be stapled.

- 4** Slide the Paper Guide Plate to the size of the copy paper.

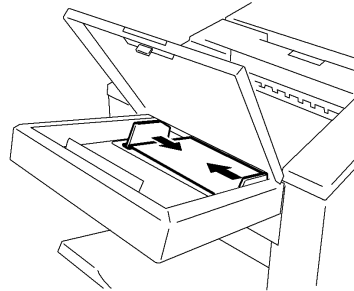

1155O034AA

NOTE

Make sure that the Paper Guide Plates are in touch with the edge of the paper stack.

- 5** Close the Manual Staple Tray Cover.

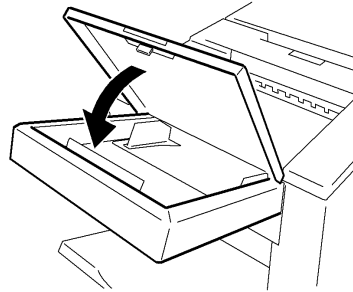

1155O035AA

- 6** After you hear the mechanism stop, select the desired stapling type on the Finisher Panel.

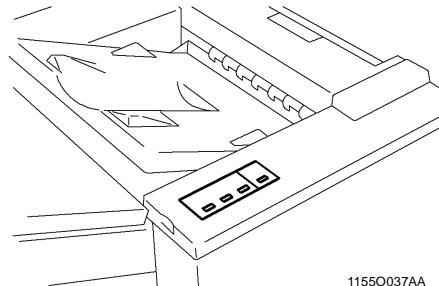

1155O037AA

You have a choice of the following three stapling positions.

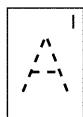

Paper size :
11"×17"L, LegalL,
LetterL, LetterC
Number of sheets :
2 ~ 50

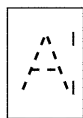

Paper size :
11"×17"L, LegalL,
LetterL, LetterC
Number of sheets :
2 ~ 50



Paper size :
11"×17"L, LegalL,
LetterL, LetterC
Number of sheets :
2 ~ 50

1155O769EA

- 7** Press . This staples the copy stack or set.

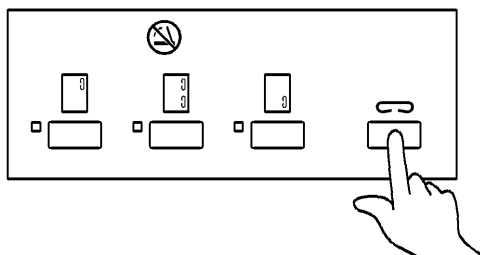

1155O038AA

Useful Tip

This feature is useful for stapling originals after making copies.

- 8** Open the Manual Staple Tray Cover and remove the stapled paper stack.

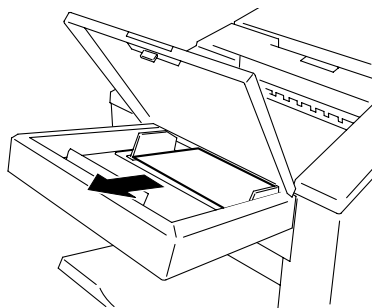

1155O760AA

- 9** Close the Manual Staple Tray Cover.

5. Selecting the Finishing

Folding

<Crease>

Crease makes a crease in the copy at its center before it is fed out.

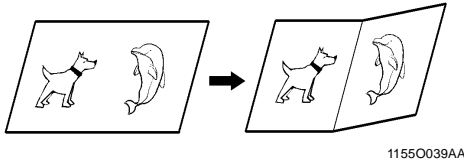

1155O039AA

Sizes of paper that can be loaded:
11"×17"L, LetterL

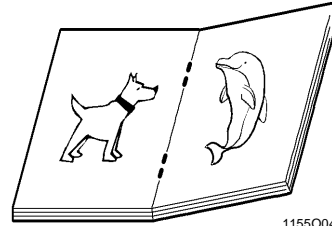

1155O040AA

Number of sheets: 2~15

NOTE

Even if Staple is previously set to a corner or side position, the setting of Crease automatically cancels this setting and reselects a center stapling position.

- 1 Touch the desired finishing function key.
Touch **Folding**.

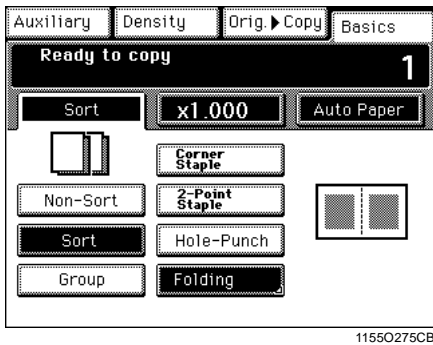

1155O275CB

- 2 Touch **Crease**.

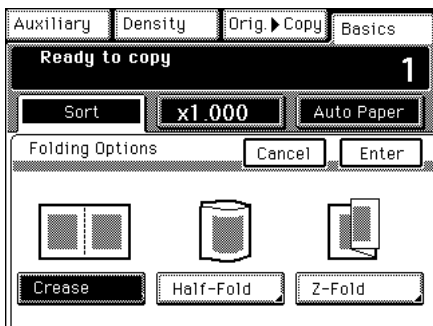

1155O276CB

- 3 Touch **2-Point Staple**.

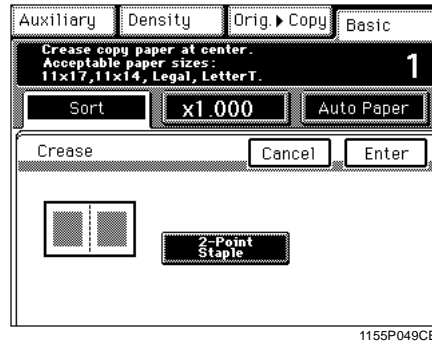

1155P049CB

- 4 Touch **Enter**.

5. Selecting the Finishing

<Half-Fold>

Half-Fold folds the copy in two at its center with the copy surface on the outside.

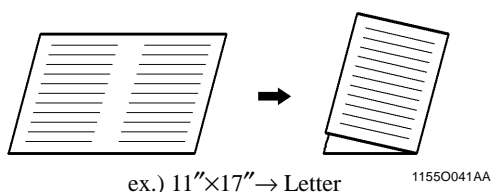

Sizes of paper that can be loaded: 11"×17"L

*The finished copy size has a length half that of the paper loaded in the copier.

You can produce a document that looks like below by combining this function with Staple and Hole Punch.

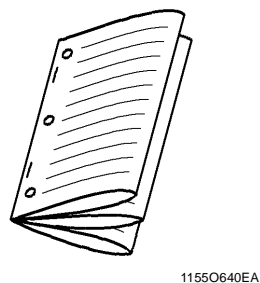

Number of sheets: 2~10

NOTE

- Half-Fold cannot be used if you make a copy from an original placed directly on the Original Glass.
- Even if Staple is previously set to a corner or center position, the setting of Half-Fold automatically cancels this setting and reselects a side stapling position.

- 1** Touch the desired finishing function key.
Touch **Folding**.

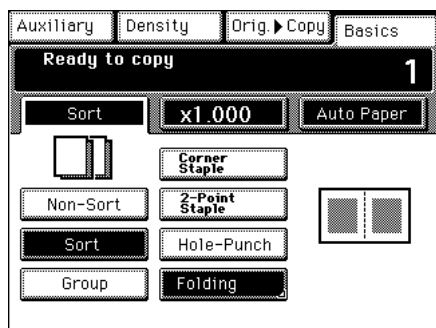

- 2** Touch **Half-Fold**.

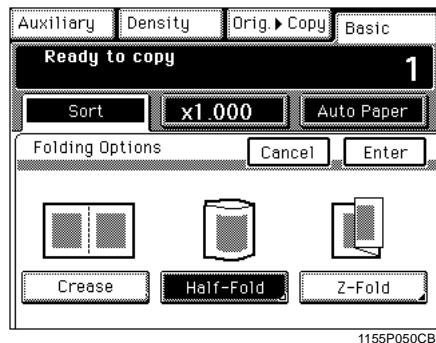

- 3** To set Staple, touch **2-Point Staple**.

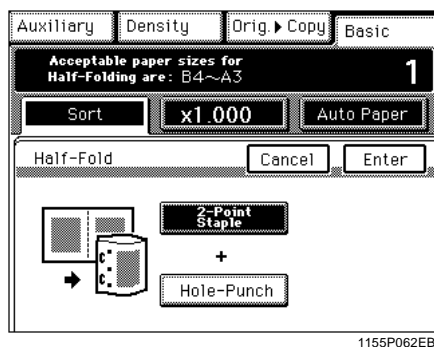

- 4** To set Hole Punch, touch **Hole-Punch**.

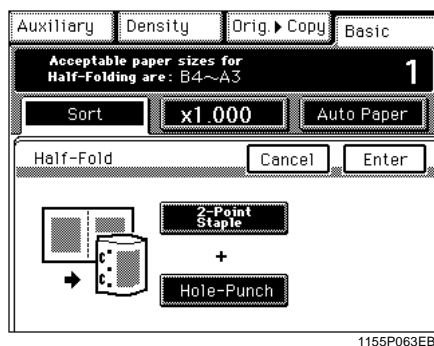

- 5** Touch **Enter**.

5. Selecting the Finishing

<Z-Fold>

Z-Fold folds the copy into three parts with the copy surface inside as shown below.

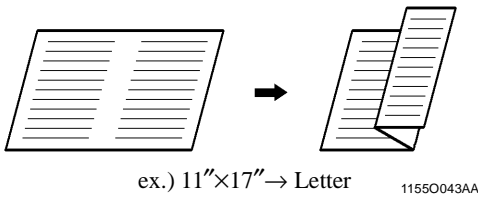

Sizes of paper that can be loaded: 11"×17"L

*The finished copy size has a length half that of the paper loaded in the copier.

This feature comes in handy when you combine it with Mixed Original Detection to make a document of the same size or when you make copies for filing.

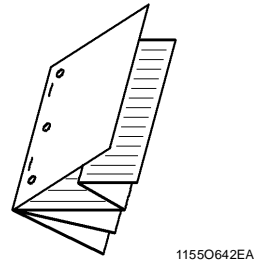

Number of sheets: Only for Z-Folded 2~10
Z-Folded 5 sheets Unfolded 25 sheets.

NOTES

- Z-Fold cannot be used if you make a copy from an original placed directly on the Original Glass.
- Even if control panel settings are made to make 2-sided copies from 1-sided originals, the copies to be Z-Folded will be 1-sided.
- If control panel settings are made to make 2-sided copies from 2-sided originals, the copies to be Z-Folded will be 2-sided.
- Even if Staple is previously set to center position, the setting of Z-Fold automatically cancels this setting and reselects a side stapling position.

1 Touch the desired finishing function key.
Touch **Folding**.

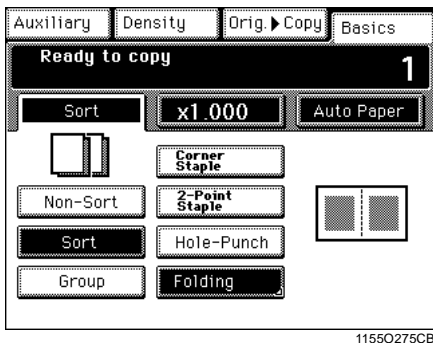

2 Touch **Z-Fold**.

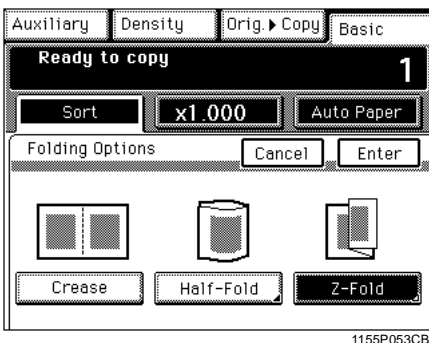

3 Touch **LTR** of Output Size.

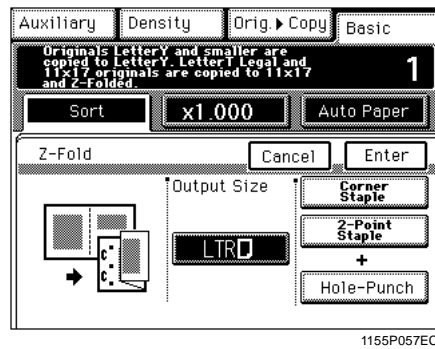

4 To set Staple, touch **Corner Staple** or **2-Point Staple**.

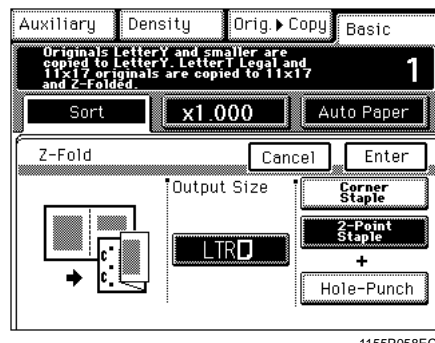

- 5 To set Hole Punch, touch **Hole-Punch**.

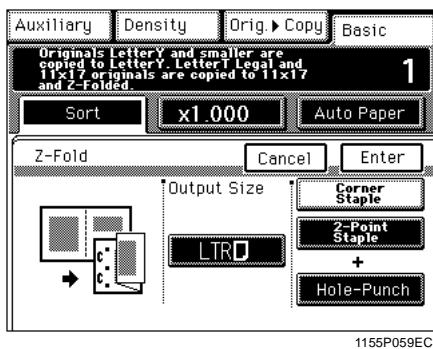

- 6 Touch **Enter**.

Loading the Originals

Staple

Note the correct direction of the originals if the copies are to be stapled in Staple Mode.

<Using the Document Handler>

	Panel	Original Placement
Corner Staple		<p>Stapling Position</p> <p>1155O532AA</p>
2-Point Staple	<p>1155O430AA</p>	<p>Stapling Position</p> <p>1155O534AA</p>
	<p>1155O431AA</p>	<p>Stapling Position</p> <p>1155O535AA</p>
	<p>1155O432AA</p>	<p>Stapling Position</p> <p>1155O536AA</p>

<Placing the Original on the Glass>

	Panel	Original Placement
Corner Staple		<p>Stapling Position</p> <p>1155O538AA</p>
2-Point Staple	<p>1155O430AA</p>	<p>Stapling Position</p> <p>1155O539AA</p>
	<p>1155O431AA</p>	<p>Stapling Position</p> <p>1155O540AA</p>
	<p>1155O432AA</p>	<p>Stapling Position</p> <p>1155O541AA</p>



Useful Tip

Refer to the instruction labels on the machine or the Document Handler.

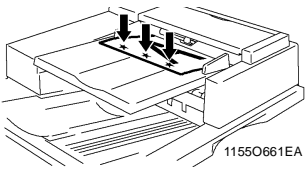

Hole Punch

Note the correct direction of the originals if the copies are to be punched using Hole Punch.

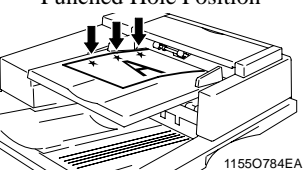
<Using the Document Handler>

Panel	Original Placement
 <p>1155O568EA</p>	<p>Punched Hole Position</p>  <p>1155O661EA</p>
 <p>1155O570EA</p>	<p>Punched Hole Position</p>  <p>1155O784EA</p>

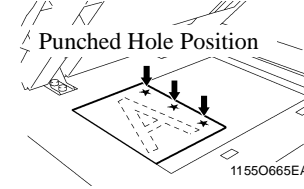
<Placing the Original on the Glass>

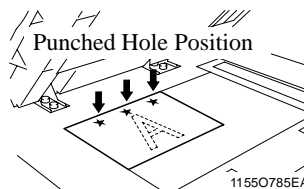
Panel	Original Placement
 <p>1155O568EA</p>	<p>Punched Hole Position</p>  <p>1155O665EA</p>
 <p>1155O570EA</p>	<p>Punched Hole Position</p>  <p>1155O785EA</p>

Auto Dual Function

Auto Dual Function in Finishing Mode

Though the Top Offset Tray can hold only up to 100 sheets, the Auto Dual function permits making copies of up to 2,100 sheets.

<Only when the Finisher FN-3 is mounted>

		Paper Size	Top Offset Tray	Bottom Offset Tray		
				Corner Staple	2-Point Staple	
Non-Sort Sort Group		LetterC	100 sheets	2000 sheets (no staple)		
		11"×17"L, LegalL, LetterL	100 sheets	1000 sheets (no staple)		
		5-1/2"×8-1/2L, 5-1/2"×8-1/2"C	100 sheets	-		
Crisscross Sort		LetterL, LetterC	100 sheets	1000 sheets (no staple)		
Staple	Sort Group	Corner	11"×17"L to Letter	-	100 sets or 1000 sheets	-
		Side	LetterC	-	-	200 sets or 2000 Sheets
			11"×17"L, LegalL, LetterL	-	-	200 sets or 1000 Sheets
	Center	11"×17"L, LetterL	-	-	100 sets or 1000 sheets	
Folding	Crease	Staple	11"×17"L, LetterL	-	-	100 sets or 1000 sheets
	Half-Fold	Non-Sort, Sort, Group	11"×17"L	10 sheets	50 sheets (no staple)	
		Staple	11"×17"L	-	-	100 sheets
	Z-Fold	Non-Sort, Sort, Group	11"×17"L	10 sheets	50 sheets (no staple)	
Staple		11"×17"L	-	100 sheets	100 sheets	
Mixed Orig. Detection	Z-Folded + Unfolded*		11"×17" (Z-Folded) + LetterC	30 sheets	Z-Folded: 100 sheets Z-Folded + Unfolded*: 1000 sheets (no staple)	
			Z-Folded: 5 sheets/set Unfolded: 2 sheets/set	-	Z-Folded: 100 sheets Z-Folded + Unfolded*: 1000 sheets	Z-Folded 100 sheets Z-Folded +Unfolded*: 2000 sheets

* Only 11"×17" size paper can be Z-folded. Therefore, if a stack of mixed-size originals (11"×17" and other sizes) is copied in Mixed Original Detection mode, the copy set will contain a mix of Z-folded and unfolded copies.

Auto Dual Function in Stapling

If a stapling sequence is attempted and the number of sheets is greater than the stapling capacity, Stapling is automatically canceled and the Finisher is set into the Sort or Group mode, sorting or grouping copies using the Auto Dual function (but no stapling action takes place).

6. Selecting the Original ▶ Copy Type

In the following pages, we shall look at how to make the settings for the type of copy you want to make from the type of original you have. When you touch **Orig. ▶ Copy** on the Touch Panel, a screen appears that allows you to set the orig. ▶ copy type.

Original ▶ Copy Types

Select 1 ▶ 1 to make 1-sided copies from 1-sided originals.

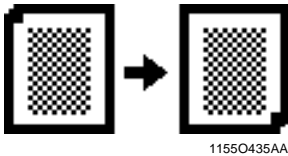

Select 2 ▶ 1 to make 1-sided copies from 2-sided originals.

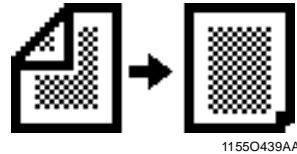

Select 1 ▶ 2 to make 2-sided copies from 1-sided originals.

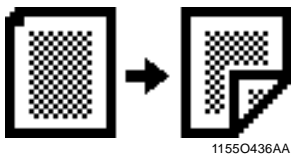

Select 2 ▶ 2 to make 2-sided copies from 2-sided originals.

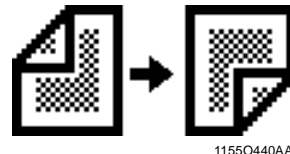

Select 1 ▶ 1 [2in1] to make a 1-sided copy, through reduction, from two 1-sided originals side-by-side.

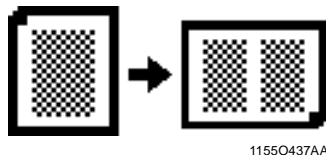

Select 2 ▶ 1 [2in1] <accessed via 2in1> to make a 1-sided side-by-side copy, by reduction, from a 2-sided original.

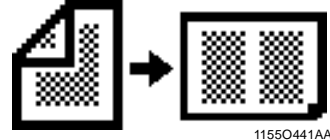

Select 1 ▶ 2 [2in1] to make a 2-sided copy, through reduction, from four 1-sided originals. Each pair of originals will be placed side-by-side on either side of the copy.

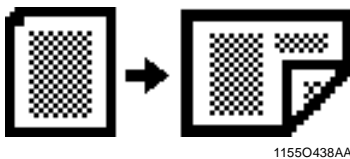

Select 2 ▶ 2 [2in1] <accessed via 2in1> to make a 2-sided side-by-side copy, by reduction, from two-sided originals.

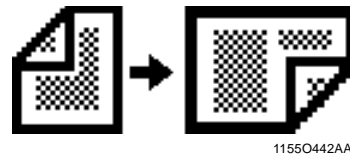

6. Selecting the Original ▶ Copy Type

Select 1 ▶ 1 [4in1] to copy 4 different 1-sided originals onto one side of a single sheet of paper.

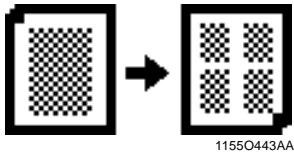

Select 2 ▶ 1 [4in1] to copy 2 different 2-sided originals (4 pages) onto one side of a single sheet of paper.

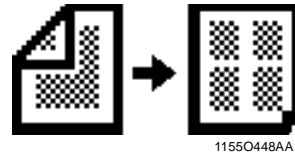

Select 1 ▶ 2 [4in1] to copy 8 different 1-sided originals onto both sides of a single sheet of paper, each side containing 4 pages of the originals.

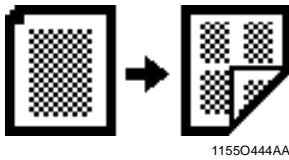

Select 2 ▶ 2 [4in1] to copy 4 different 2-sided originals (8 pages) onto both sides of a single sheet of paper, each side containing 4 pages of the originals.

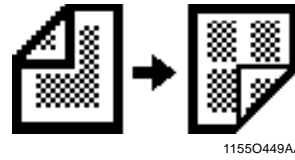

Select 1 ▶ Booklet Creation to copy 4 different 1-sided originals onto both sides of a single sheet of paper.

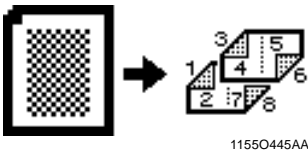

Select 2 ▶ Booklet Creation to copy 2 different 2-sided originals onto both sides of a single sheet of paper.

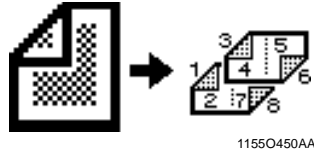

Select Book ▶ 1 to make 1-sided page-by-page copies of an open book.

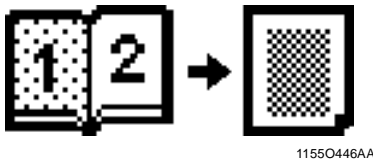

Select Book ▶ 2 to make a 2-sided copy of an open book. Each page of the open book will be copied onto one side of the copy.

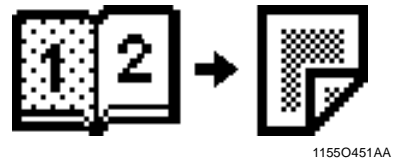

Select Book ▶ Booklet Creation to copy 4 pages of a book onto both sides of a single sheet of paper.

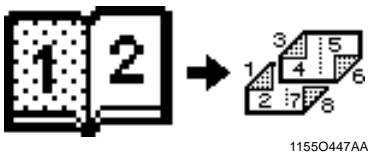

Selecting the Original ▶ Copy Type

Using 1 or 2 Originals

1 Load the Originals.

2 Select the Original Type.

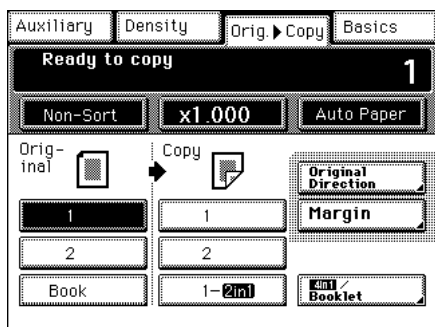

3 Select the desired copy type.

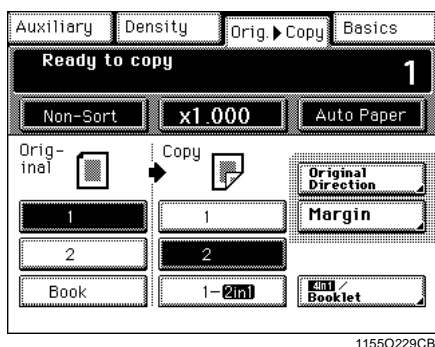

<To copy using 2 ▶ 2[2in1], Booklet,
1 ▶ 1[4in1], 2 ▶ 2[4in1]>

• Touch **4in1 / Booklet** in step 3.

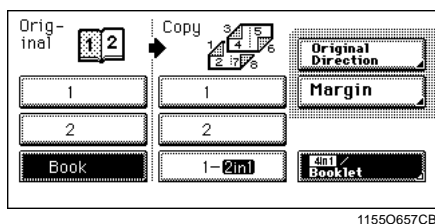

• Select the desired copy type and touch **Enter**.

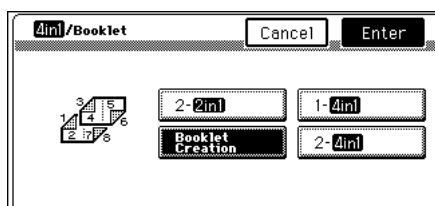

Original Direction Key:

Use this key when you want to place your original in a direction other than the standard.

1 Touch **Original Direction**.

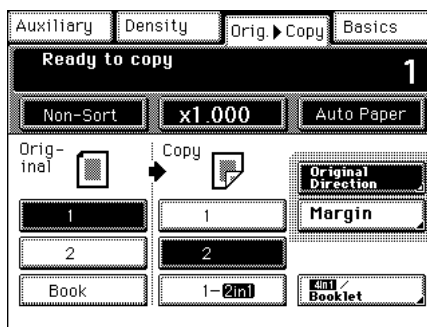

2 Select the position of the original.

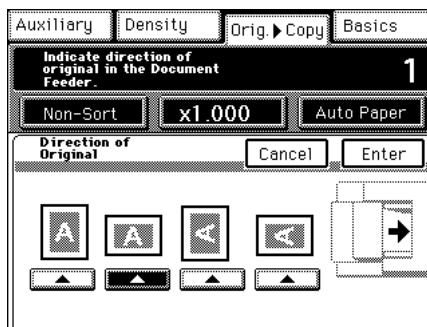

3 Touch **Enter**.

6. Selecting the Original ▶ Copy Type

Margin key for the original:

When you're going to make copies using 1 ▶ 2 or 2 ▶ 1, first check to see if your original has a file margin in it. The copier can correct the margin position to make good copies as long as you instruct it properly.

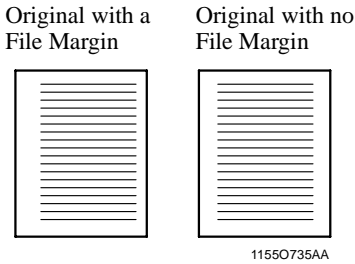

3 Hold down the  or  key until the desired margin width is reached.

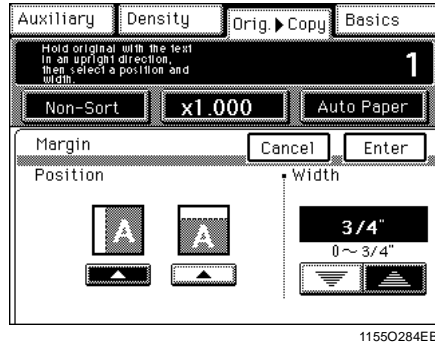

Useful Tip

You can change the margin width in 1/16" increments within the range 0" ~ 3/4".

If your original has a file margin

1 Touch **Margin**.

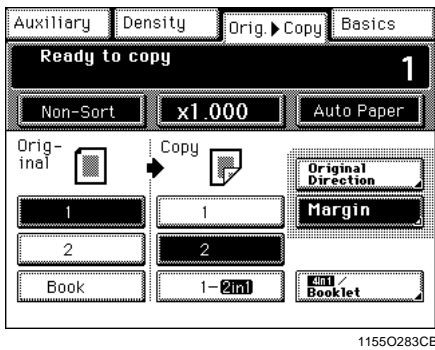

2 Select the desired margin position. You have a choice of the following two Margin Positions.

• Margin Position (Left)

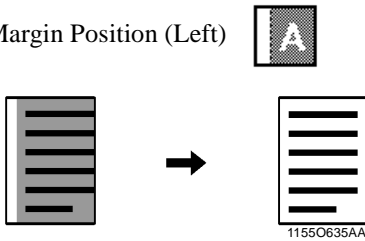

• Margin Position (Top)

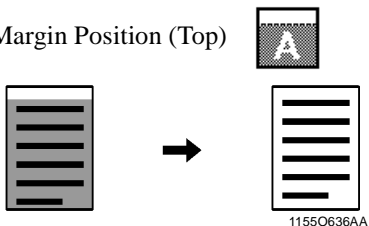

4 Touch **Enter**.

Useful Tips

• If the margin position is set to Left and width to 0", the image on both the front and back sides of the copy has the same orientation as that on the original.

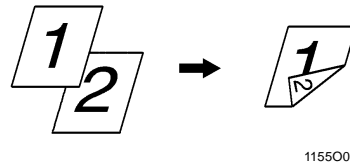

• If the margin position is set to Top and width to 0", the image on the 2nd side of the copy is inverted to that on the 1st side.

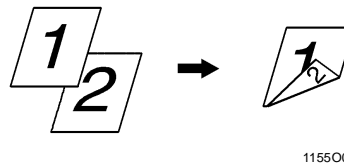

If your original has no file margin

It's not necessary to correct the margin position and width if your original has no file margin.

Book

1 Position the book on the glass.

2 Touch **Book**.

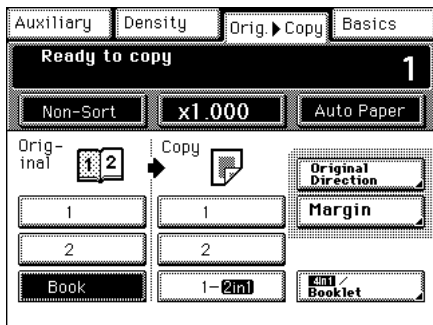

11550288CB

3 Touch **Standard Book** or **Right Bound**.

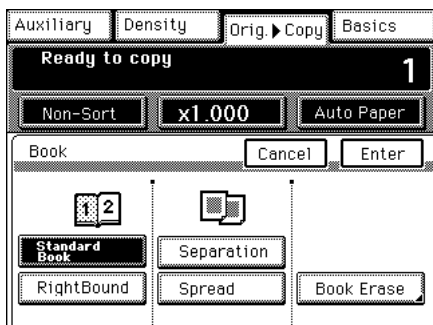

11550289CB

4 Touch **Separation** or **Spread**.

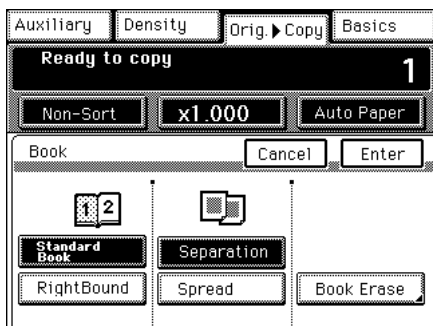

11550290CB

5 If you want to erase the four edges or center, touch **Book Erase**.

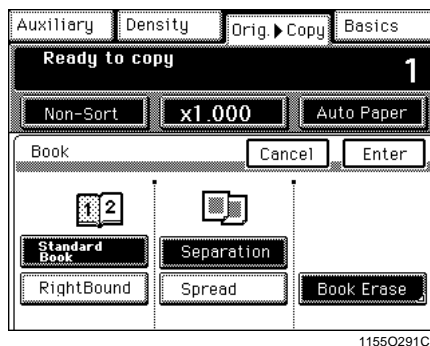

11550291CB

Useful Tip

You have a choice of the following three erase functions.

- Frame Erase 
Erase a given width along the four edges.

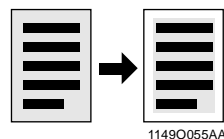

11490055AA

- Center Erase 
Erase a given width down the center.

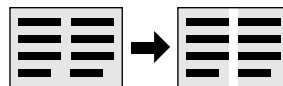

11490057AA

- Frame + Center Erase 
Erase a given width along the four edges and down the center.



11490058AA

6. Selecting the Original ▶ Copy Type

- 6 Select the particular erase function (“Book Erase”).

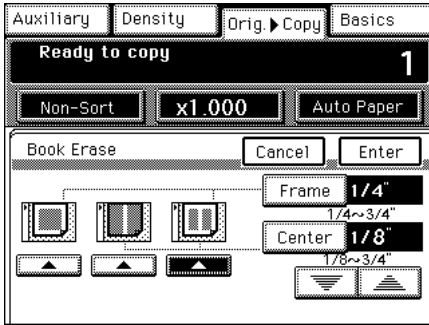

1155O296EC

- 7 Touch **Frame** or **Center**, then hold down the or key until the desired erase width is reached. Then, touch **Enter**.

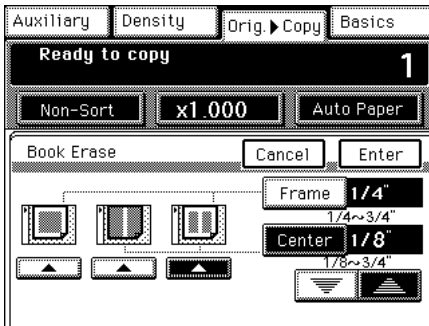

1155O298EB

<To copy Using Booklet>

- Touch **4in1 / Booklet** in step 9.

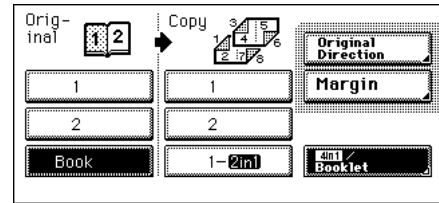

1155O657CB

- Touch **Booklet Creation**.

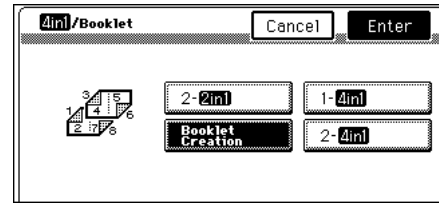

1155O658CA

- Input the copy starting page position and last page position. Then touch **Enter**.

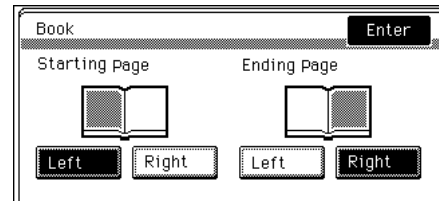

1155O659CA

Useful Tip

You can change the erase width in 1/6" increments within the following range:

- Frame: 1/4"~3/4"
- Center: 1/8"~3/4"

- 8 Touch **Enter**.

- 9 Touch the **1**, **2** or **Booklet** keys in the Orig. ▶ Copy Mode.

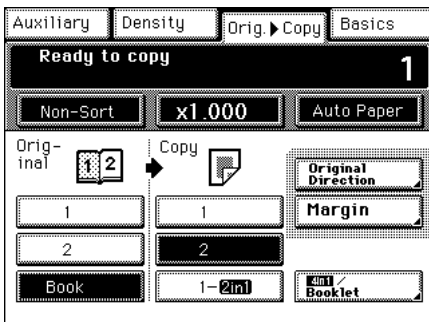

1155O303CB

<To copy using Separation and 2-sided>

- Touch **Page arrange**.

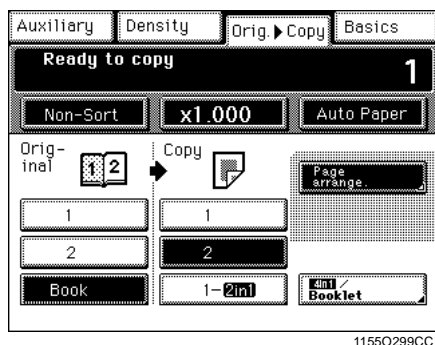

You have a choice of the following two arrangement types.

- Book Order 

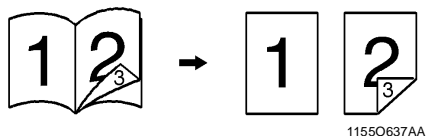

- Standard 

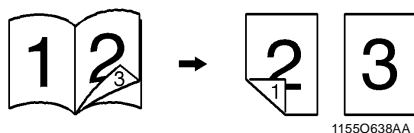

- Select the desired page arrangement.

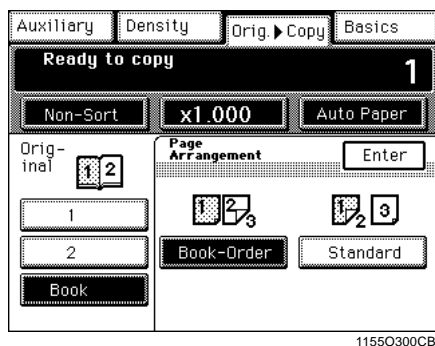

- Touch **Enter**.

Some Precautions for Making Copies

Precautions for Book Copying

- Place the open book so that its top edge is at the rear of the copier and the center of the book is aligned with the Book Marker indicated on the Original Length Scale.
- Make copies in descending order of page.
- Select the desired zoom ratio and copy paper size.

Placing the Book on the Glass Correctly

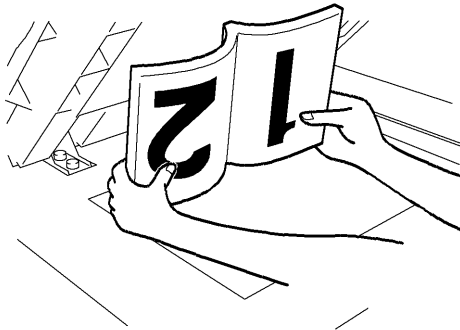

11550027AA

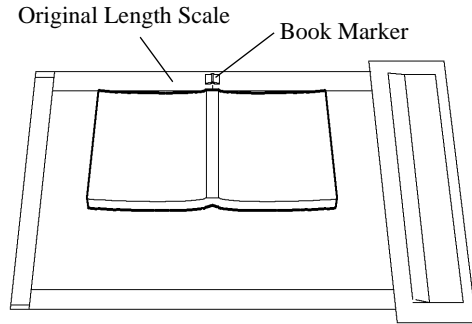

11550697AA

Precautions for 2-in-1, 4-in-1 and Booklet Copying

- When the 2-in-1, 4-in-1 or Booklet function is selected, the copier automatically selects a default zoom ratio. However, you can choose another zoom ratio by changing the User's Choice setting. ☞p. 4-16
- User's Choice also allows you to program a specific page order for 4-in-1. ☞p. 4-17

7. Selecting the Density

Image Density

In the following pages, we explain how to set the exposure level for the image density.

When you touch **Density** on the Touch Panel, a screen appears that allows you to set the exposure level for the image density. You have a choice of three different ways to adjust the exposure level: Auto Exposure, Manual Exposure, or Photo mode. Select the appropriate mode according to your particular needs.

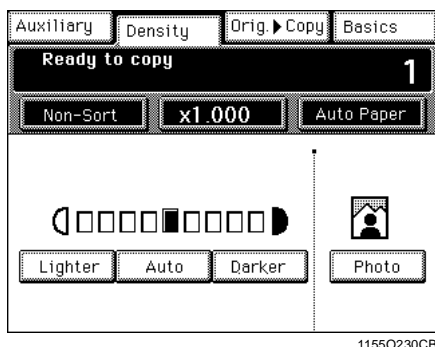

Auto Exposure

When in the Auto Exposure mode, the copier automatically adjusts the exposure level for the optimum copy image density.

- 1 Touch **Auto**.
The **Auto** key is highlighted, indicating that the copier is set into the Auto Exposure mode.

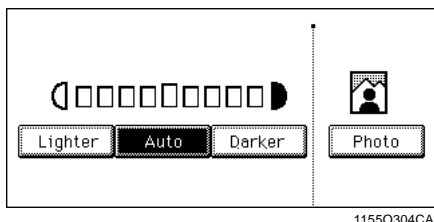

Useful Tips

- The exposure level in the Auto Exposure mode can be made either “Darker” or “Lighter” by using User's Choice. ☞ p. 4-16
- The copier has been factory-set to automatically select the Auto Exposure mode. User's Choice can be used to change this default setting to the Manual Exposure mode. ☞ p. 4-16

Manual Exposure

In the Manual Exposure mode, you can vary the exposure level in nine steps.

- 1 Touch **Lighter** or **Darker** as necessary.

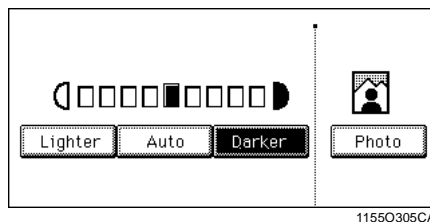

Useful Tips

- To make the image darker, touch **Darker**.
- To make the image lighter, touch **Lighter**.

7. Selecting the Density

Photo

The copier can make a faithful reproduction of an original having a halftone image such as photos. The exposure level of the photo may be varied in nine steps.

- 1 Touch **Photo**.
The **Photo** key is highlighted, indicating that the copier is set into the Photo mode.

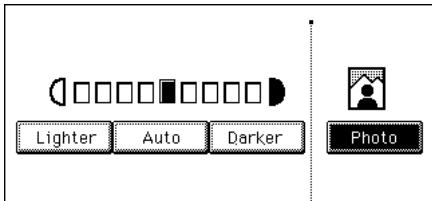

1155O306CA

- 2 Touch **Lighter** or **Darker** as necessary.

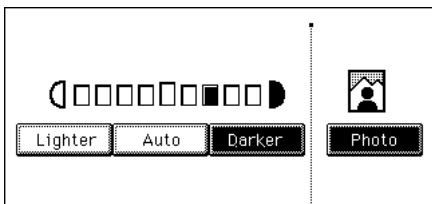

1155O307CA

NOTE

When making copies in the Photo Mode, Auto Exposure does not operate. Select the desired exposure level in the Manual Exposure Mode.

Useful Tips

- To make the image darker, touch **Darker**.
- To make the image lighter, touch **Lighter**.

8. Auxiliary Functions

These pages explain about convenient functions offered as the Auxiliary functions and how to set these features. When the **Auxiliary** key on the Touch Panel is touched, the Auxiliary function menu screen appears.

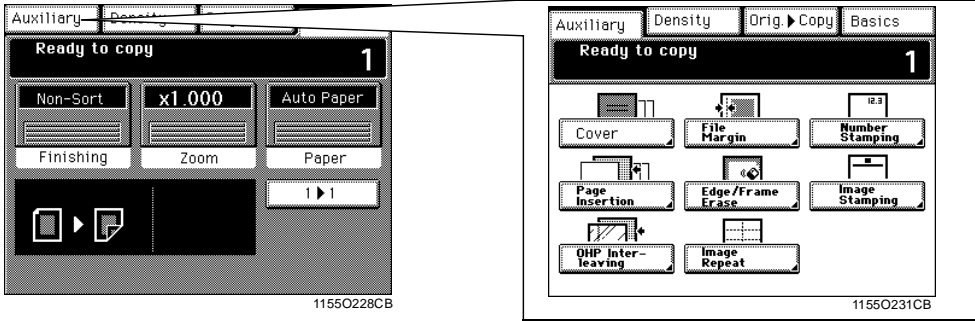

Cover

The Cover mode lets you make a front cover or a front and back cover for a copy set by copying the first page or the first and last page of an original set on different paper from the normal copy paper, such as color paper. There are six different Cover functions available. Select the appropriate one according to your need.

Functions

Front Cover: Copied
Back Cover: None

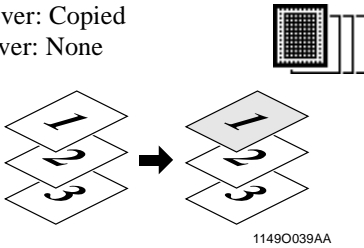

Front Cover: Blank
Back Cover: None

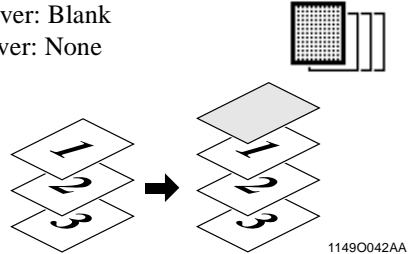

Front Cover: Copied
Back Cover: Blank

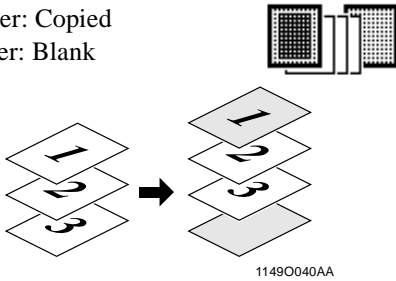

Front Cover: Blank
Back Cover: Blank

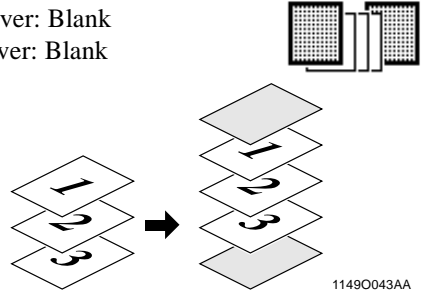

Front Cover: Copied
Back Cover: Copied

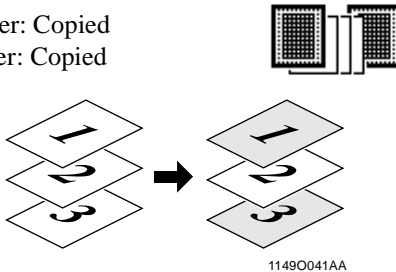

Front Cover: Blank
Back Cover: Copied

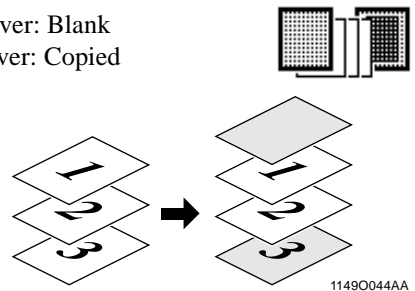

Using the Cover Mode

- 1 Load your originals into the document handler.

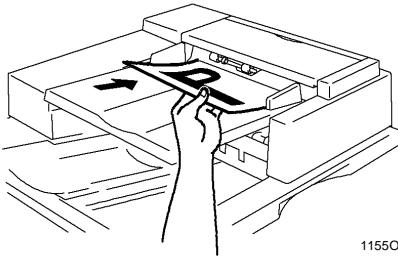

1155O023AA

- 2 Touch **Cover**.

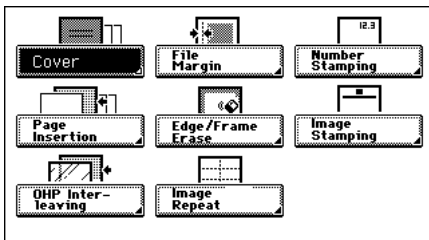

1155O309CA

- 3 Select the key for the front cover.

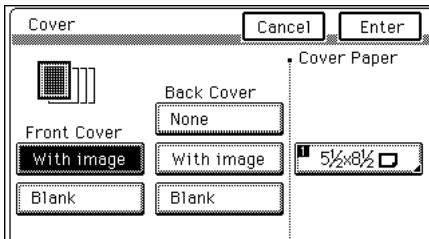

1155O311EA

- 4 Select the key for the back cover.

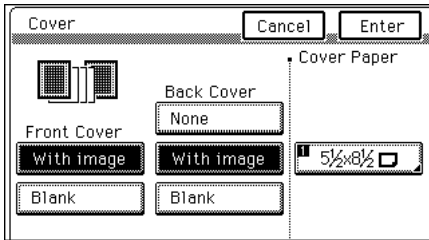

1155O313EA

- 5 Load the paper for the cover (e.g., color paper) into the drawer.

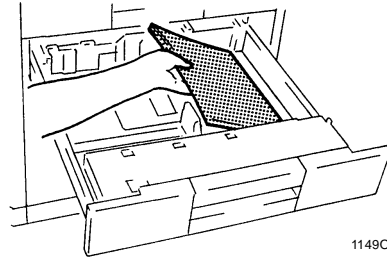

1149O093AA

Useful Tip

You can use the Multi Bypass Tray as the source of the cover paper.

- 6 Touch the key for Cover Paper.

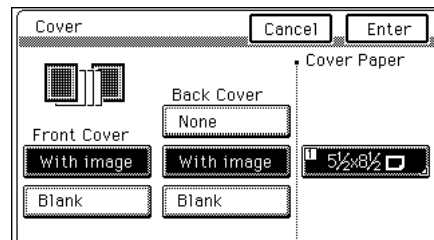

1155O315EA

- 7 Select the drawer in which paper for the cover has been loaded in step 5.

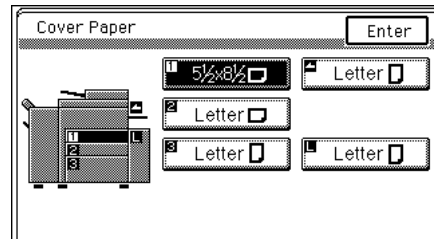

1155O317EA

- 8 Touch **Enter**.

- 9 Touch **Enter**.

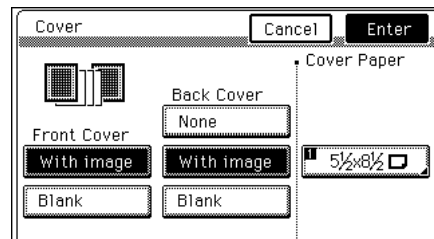

1155O319EA

Page Insertion

Page Insertion allows you to insert a special sheet of paper (e.g., color paper) into the copy set. Two different functions are available. Select the appropriate one according to your need.

Functions

Page Insertion <Copied Inserts>

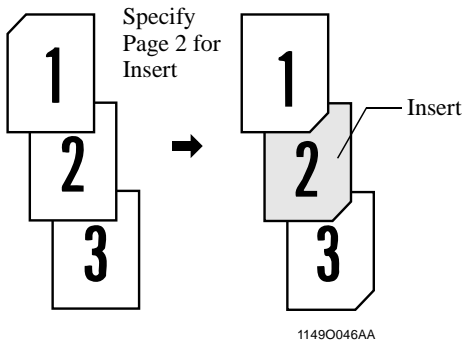

The copier copies the page, which is specified for an insert, on paper for inserts (e.g., color paper).

Page Insertion <Non-Copied Inserts>

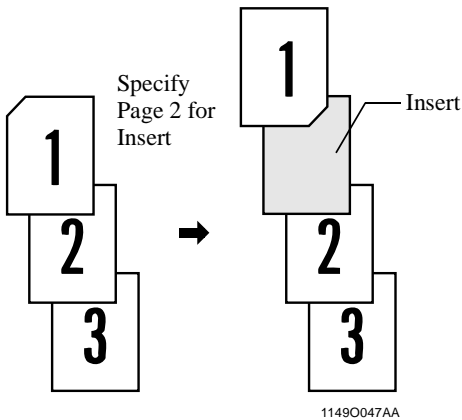

The copier inserts a blank sheet of paper for inserts (e.g., color paper) at any specified place between pages.

8. Auxiliary Functions

Specifying the Place for an Insert

In the Page Insertion mode, you must specify where to place an insert by using Automatic Detection.

Automatic Detection

Put a sheet of paper of a different size from the originals at your desired places in the original set (for convenience, let us call this paper the insert marker), load the original set onto the document handler and let the copier start the original count sequence.  p. 3-49

<The copier automatically detects and sets the places for inserts.>

NOTE

Automatic Detection cannot be performed when the Mixed Original Detection mode is set.

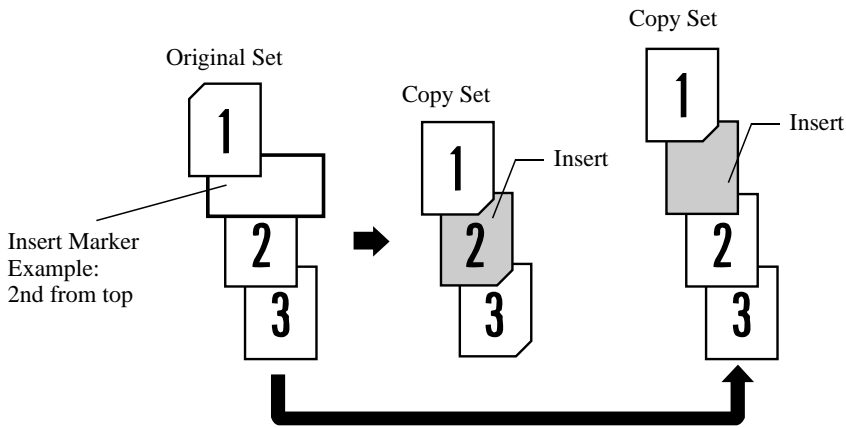

Using Page Insertion

- 1 Put an insert marker into the desired place in the original set.

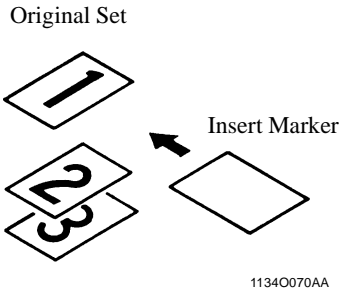

Example 1: To place a copied insert at the 2nd position from top.

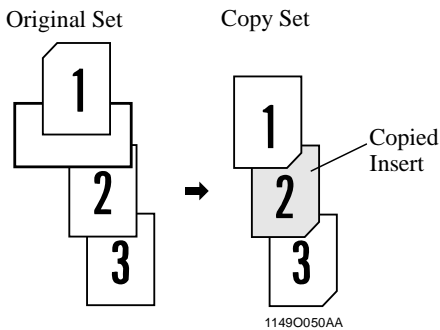

Example 2: To place a non-copied insert between pages 1 and 2.

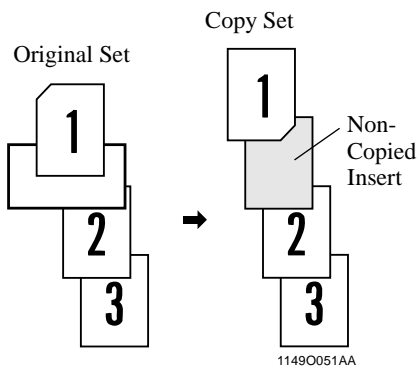

NOTE

For the insert marker, use paper that is a size, or loaded in a direction, different from the originals.

- 2 Load the original set containing insert markers into the document feeder.

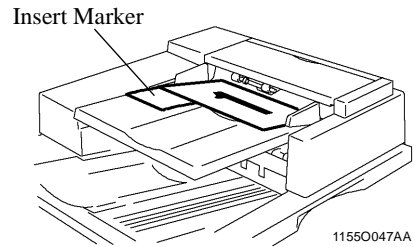

- 3 Touch **Page Insertion**.

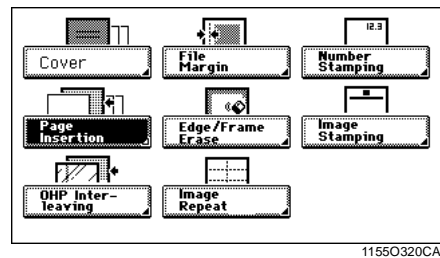

- 4 Touch the appropriate key for Paper to select whether to copy onto inserts (With Image) or not (Blank).

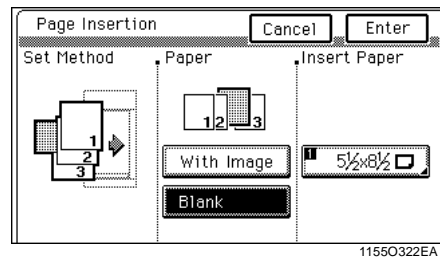

- 5 Load the paper for inserts into the drawer.

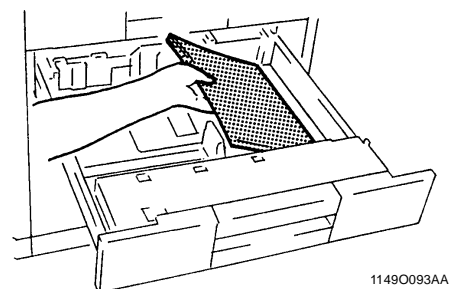

Useful Tip

You can use the Multi Bypass Tray as the source of the paper for the inserts.

8. Auxiliary Functions

- 6 Touch the paper size key for Insert Paper.

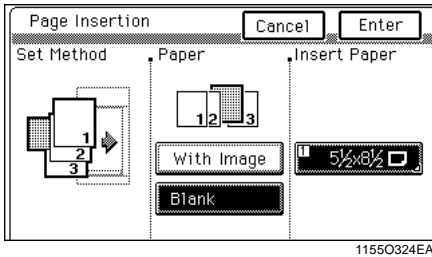

- 7 Select the paper source in which paper for inserts has been loaded in step 5.

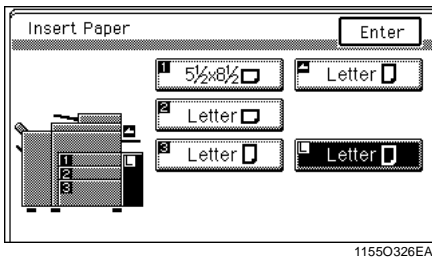

- 8 Touch **Enter**.

- 9 Touch **Enter**.

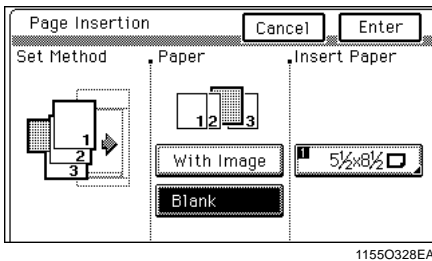

- 10 Press the Start Key to let the copier start the Auto Detection sequence.

*The document handler starts feeding the originals loaded in it to detect the insert markers and scan the originals.

OHP Interleaving

When you make copies on transparencies, the OHP Interleaving function inserts copied or non-copied interleaves after each transparency. Four different functions are available. Select the appropriate one according to your need.

Functions

Single Copy

<Copied Interleaves>

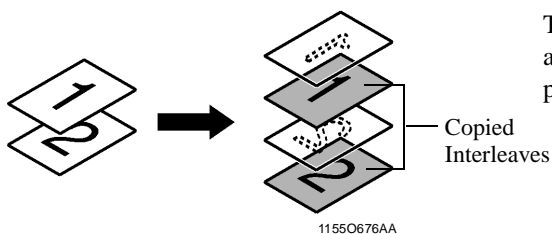

The copier copies onto OHP transparencies and, after each transparency, inserts a copied sheet of paper.

<Non-Copied Interleaves>

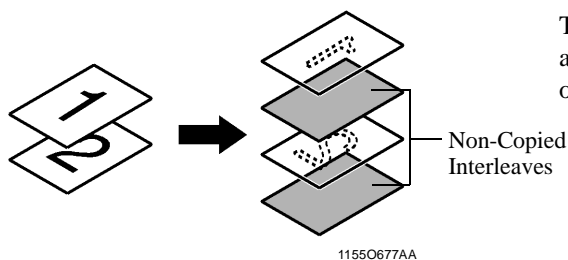

The copier copies onto OHP transparencies and, after each transparency, inserts a non-copied sheet of paper.

8. Auxiliary Functions

Multiple Copy

<Copied Interleaves>

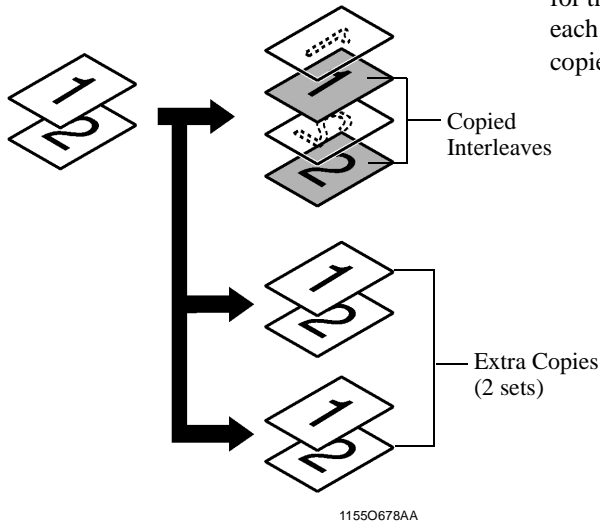

The copier copies onto OHP transparencies and, for the 1st set, inserts a copied sheet of paper after each transparency. Also, the copier sorts extra copies into a specified number of sets.

<Non-Copied Interleaves>

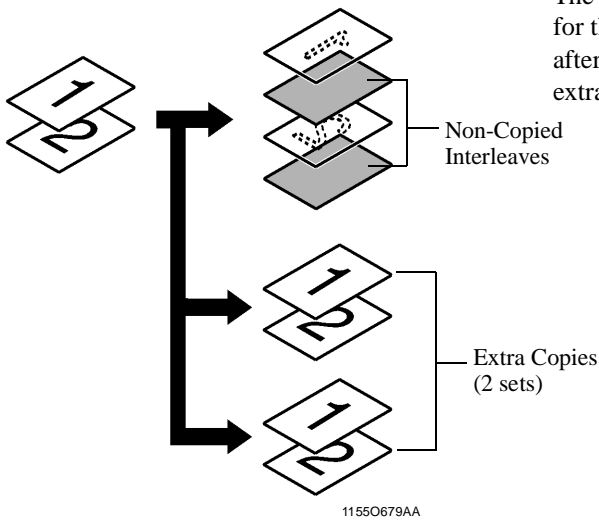

The copier copies onto OHP transparencies and, for the 1st set, inserts a non-copied sheet of paper after each transparency. Also, the copier sorts extra copies into a specified number of sets.

Useful Tip

Auto Paper, Auto Zoom, Sort, Staple, Punch, 2-sided, 2-in-1, 4-in-1, Booklet, Cover and Insertion are all available for the extra copies.

Using OHP Interleaving

1 Load the originals.

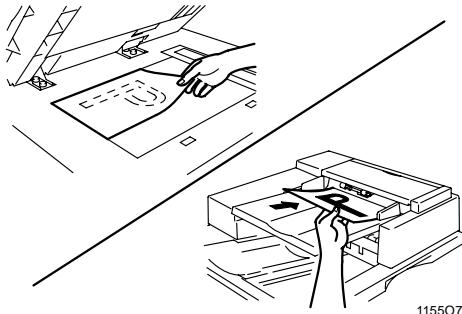

1155O757AA

NOTES

- If you make each copy through the Original Glass, start with the first page of the set. “Not Using the Document Handler” *see* p. 3-6
- When a multi-page document is copied using the Electronic Document Handler, the page order of the originals is reversed in the copy set.

2 Touch **OHP Interleaving**.

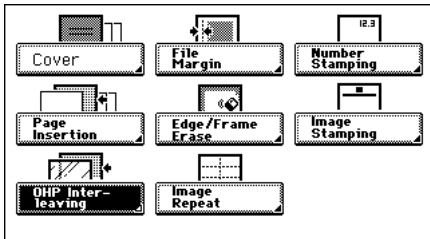

1155O329CA

3 Load OHP transparencies onto the Multi Bypass Tray. (Up to 20 sheets of OHP transparencies can be placed on the tray.)

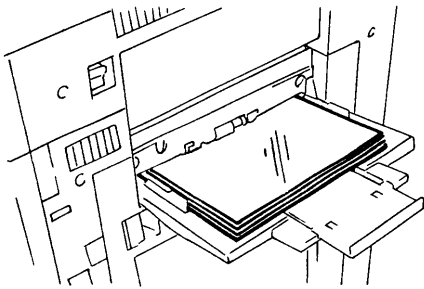

1161O086AA

4 Select a transparency size.

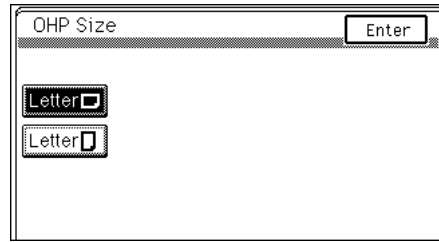

1155O337EA

5 Touch **Enter**.

6 Select whether to copy onto the interleaves (With Image) or not (Blank).

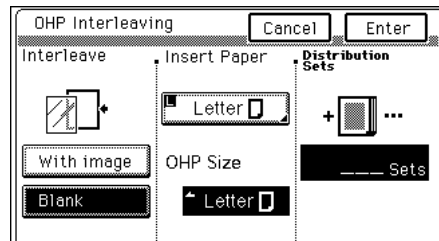

1155O331EA

7 Touch the key for Insert Paper.

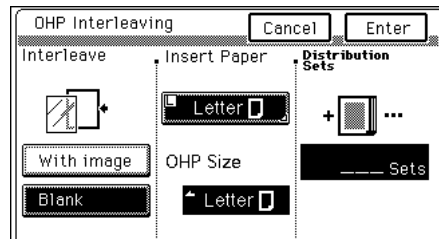

1155O333EA

8 Select the Insert Paper.

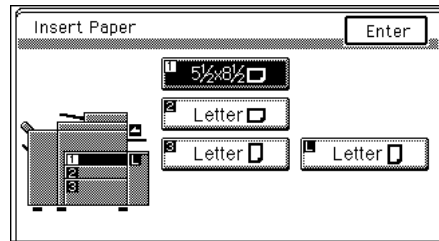

1155O335EA

9 Touch **Enter**.

8. Auxiliary Functions

- 10** Enter the number of extra copy sets to make from the 10-Key Pad.

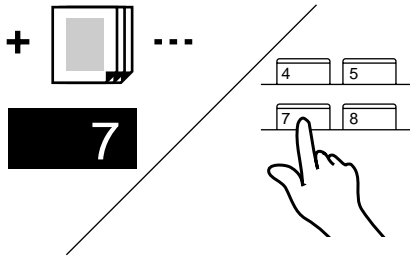

1149O052AA

NOTE

For the paper for extra copy sets, touch **Paper** on the Basics screen and select the desired copy paper.

*Auto Paper may also be used for the copies.

- 11** Touch **Enter**.

File Margin

The copier provides a file margin along the leading edge for your ease in filing. There are four different ways available for making a file margin. Use the one that is most suited to your need.

Functions

Shift-for-Margin

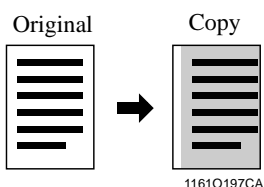

The image of the original is shifted to the right to make a margin along the left edge of the copy.

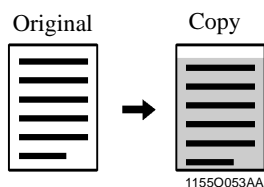

The image of the original is shifted to the bottom to make a margin along the top edge of the copy.

Margin-by-Reduction

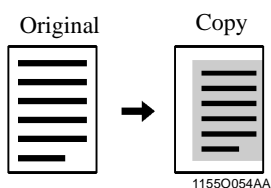

The image of the original which has almost no file margins along the sides is reduced to make a wider margin along the left edge of the copy.

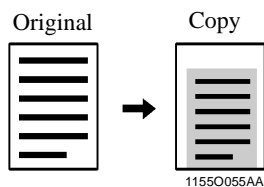

The image of the original which has almost no file margins along the sides is reduced to make a wider margin along the top edge of the copy.

Useful Tip

If the image of the original covers the entire surface of the original, Margin-by-Reduction will ensure a copy with no lost image along the edges.

Using File Margin

1 Touch **File Margin** .

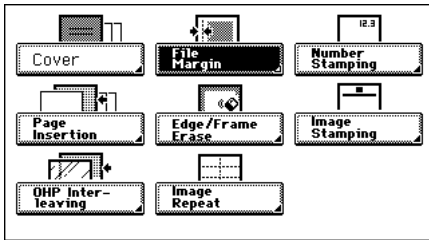

1155O338CA

2 Place the original.

3 Select the desired “Position” of the margin.

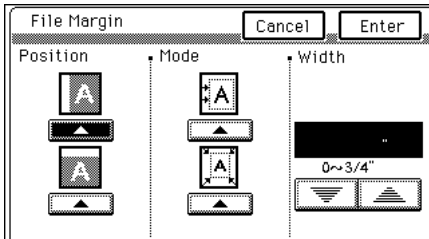

1155O340EA

4 Select the “Mode” of margin making.

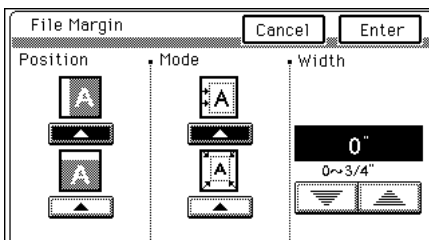

1155O342EB

5 Hold down the or key until the desired margin width is reached.

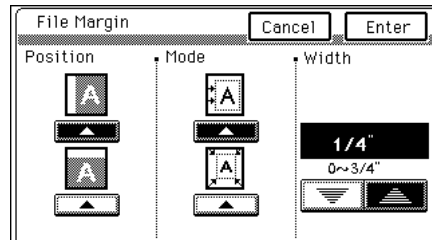

1155O344EA

NOTE

Having a margin width larger than necessary could result in part of the image missing on the copy. Try to keep a logical margin width.

Useful Tip

You can change the margin width in 1/16" increments within the range 0"~ 3/4".

6 Touch **Enter** .

Useful Tips

- If the margin position is set to Left and width to 0", the image on both the front and back sides of the copy has the same orientation as that on the original.

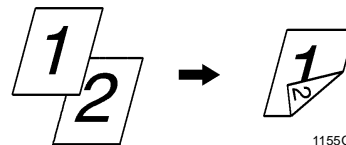

1155O045AA

- If the margin position is set to Top and width to 0", the image on the 2nd side of the copy is inverted to that on the 1st side.

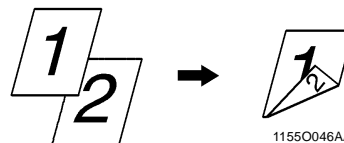

1155O046AA

Edge/Frame Erase

The copier erases a margin of a set width along the four edges, one edge, or at the center to erase shadows or other unwanted images. This feature is effective in erasing the communications record on a document received by fax. One of three different functions can be selected. Use the one that is most suited to your need.

Functions

Left Edge Erase

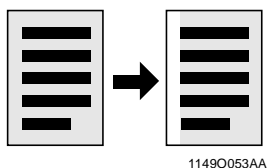

Erases a given width from the left edge of the copy.

Top Edge Erase

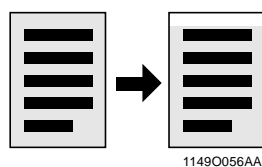

Erases a given width from the top edge of the copy.

Frame Erase

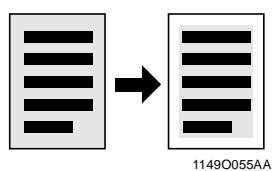

Erases a given width along the four edges.

Using a Particular Edge/Frame Erase Function

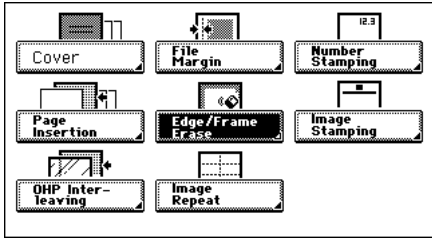

- 1 Touch **Edge/Frame Erase**.

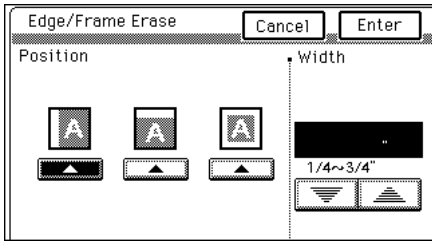

- 2 Place the original.

- 3 Select the desired erase function ("Position").



- 4 Hold down the  or  key until the desired erase width is reached.

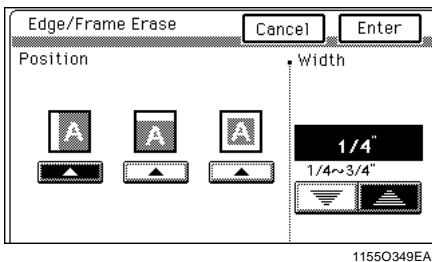

NOTE

The erase width represents that on the original, not on the copy. So, use care when making a reduction or enlargement copy.

Example: Erasing the margin of an 11"×17" size original on a copy reduced by ×0.5:

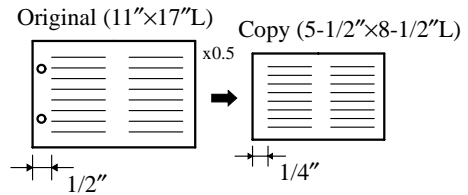

If you want to erase the 1/2"-wide margin on the original, select 1/2" for the erase width.

Useful Tip

You can change the erase width in 1/16" increments within the range 1/4" ~ 3/4".

- 5 Touch **Enter**.

Image Repeat

The image of the original is repeatedly produced on the copy paper. The copier automatically calculates the number of images that can be printed based on the copy paper size and zoom ratio.

Functions

With Dotted Line

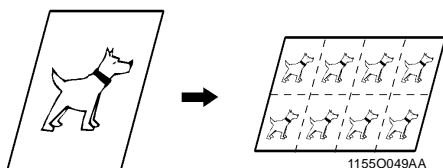

Provides dotted lines between the adjacent images on the copy.

Without Dotted Line

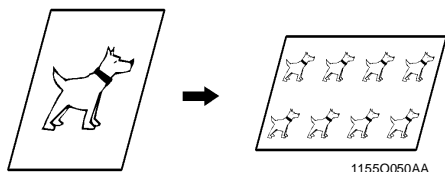

Provides no dotted lines between images on the copy.

Selecting Image Repeat

- 1 Load the originals.
- 2 Select the desired copy paper and zoom ratio.
(Selecting the Paper ↗ p. 3-9
Selecting the Zoom ↗ p. 3-14)

- 3 Touch **Image Repeat**.

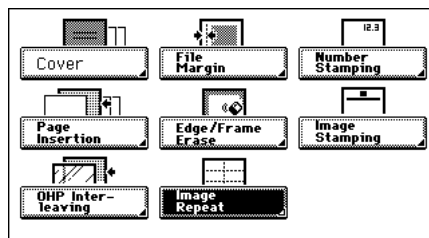

8. Auxiliary Functions

- 4 Select whether you want a dotted line or not by touching **Yes** or **No**.

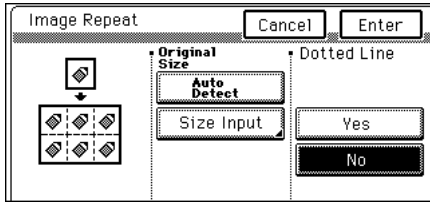

1155O752CA

- 5 Touch **Auto Detect** to detect the original size.

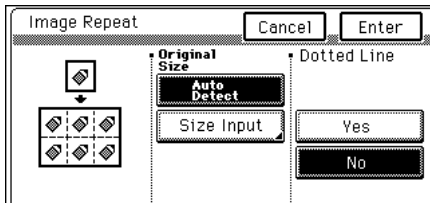

1155O351CA

NOTE

For an original placed directly on the Original Glass, enter its size using Size Input. For using Size Input, see the instructions on the right.

- 6 Touch **Enter**.

<Size Input>

- Original Size is standard

Touch **Size Input** in step 5. Select the size of the original and touch **Enter**.

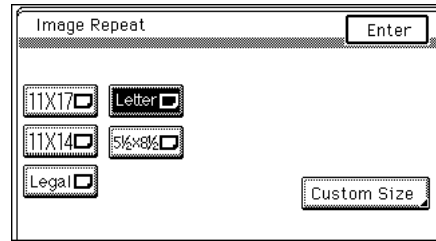



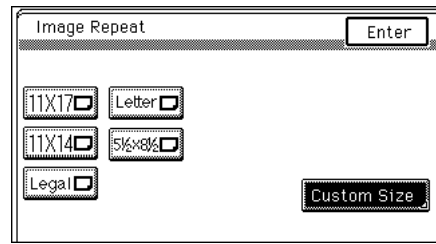

1155O353EA

- Original Size is nonstandard

Touch **Size Input**, then touch **Custom Size** in step 5.



1155O355EA

- Touch  or  to set the whole number for X and touch the **X** key. The underline moves to the right. Then touch  or  to set the fractional number and touch the **X** key. Now the value for X has been fixed.

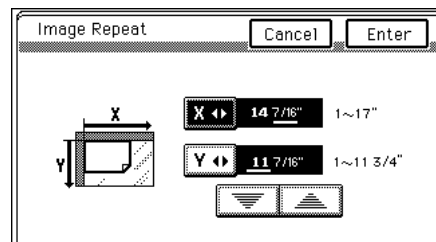

1155O357EA

- Do the same for Y, then touch **Enter**.

Number Stamping

The copier places on each copy the date of copying (Date), page number (Page) and a reference number for each copy set (Distribution).

Functions

Date

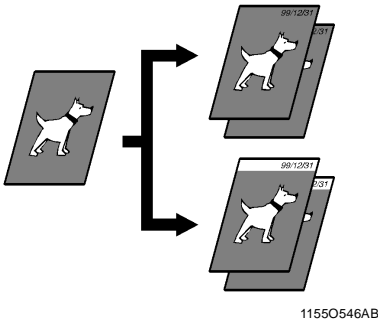

Places the date of copying on each copy.

*The image area on which the date is printed may be erased.

Page

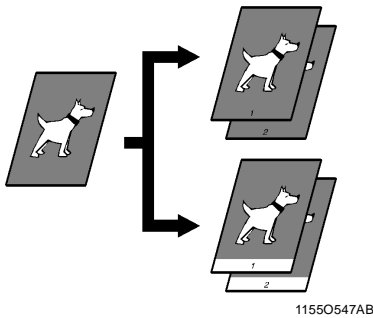

Places a page number on each copy.

*The image area on which the page number is printed may be erased.

Distribution

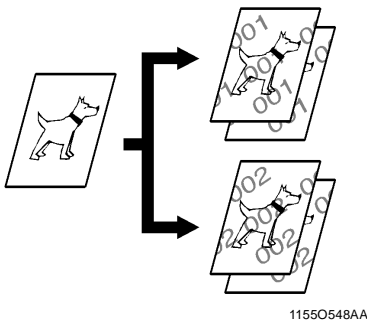

Places a reference (distribution) number on the background of the copy, as assigned to each copy set.

NOTE

Number Stamping is possible when the copier is equipped with an optional Hard Disk Drive Kit.

8. Auxiliary Functions

Using Date

1 Load your originals.

2 Touch **Number Stamping**.

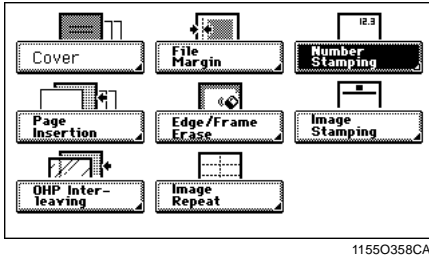

3 Touch **Date**.

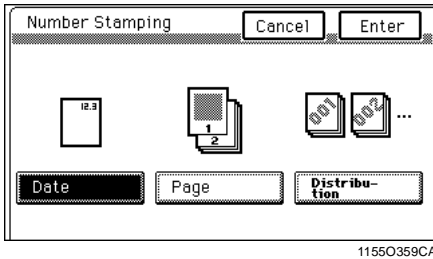

4 Select the desired date stamping position.

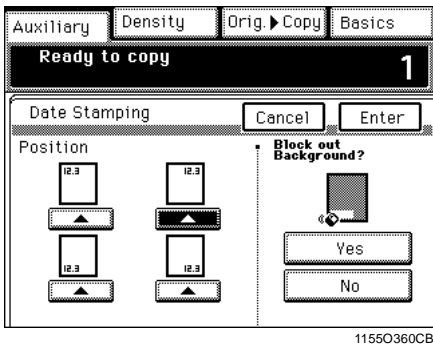

5 Select whether to block out the background **Yes** or not **No**.

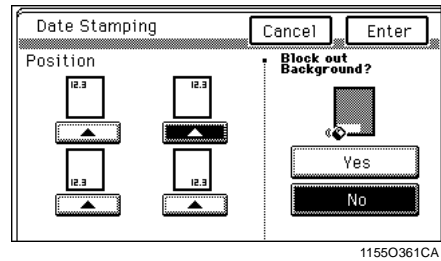

Useful Tips

- *Blocking out the background*

The background image is erased and the date is printed on the erased area.

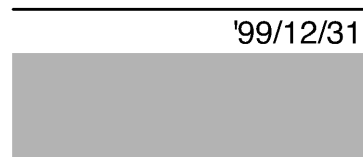

- *Not blocking out*

The date is printed over the image.

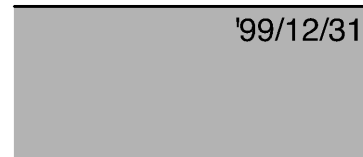

6 Touch **Enter**.

Useful Tip

User's Choice allows you to set the date and time, date printing format, and date printing position. ☞ p. 4-17, 4-19

Using Page

1 Load your originals.

2 Touch **Number Stamping**.

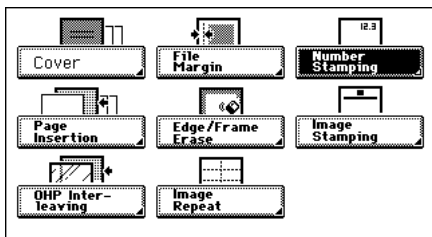

1155O358CA

3 Touch **Page**.

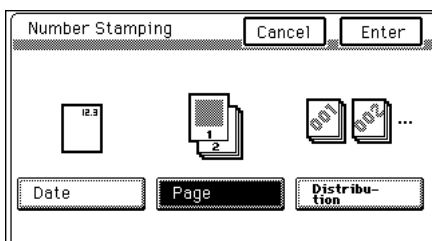

1155O362CA

4 Enter the starting number from the 10-Key Pad.

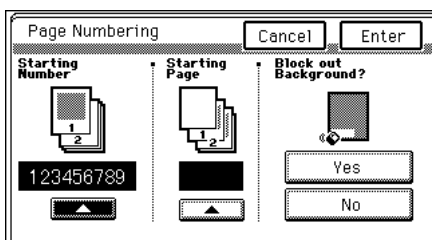

1155P037CA

5 Enter the starting page number from the 10-Key Pad.

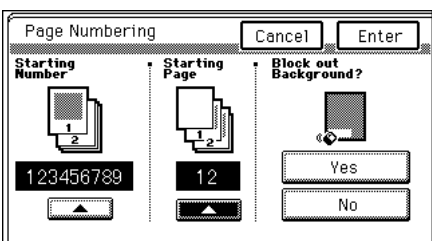

1155P038CA

6 Select whether to block out the background **Yes** or not **No**.

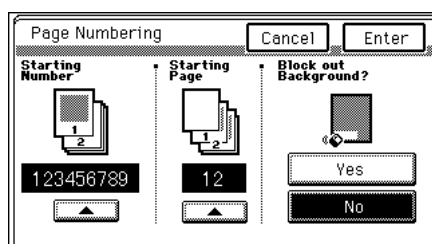

1155P039CA

Useful Tips

- *Blocking out the background*

The background image is erased and the page number is printed on the erased area.



1155O551AB

- *Not blocking out*

The page number is printed over the image.



1155O552AB

7 Touch **Enter**.

Useful Tips

- *User's Choice allows you to set the page number position.* p. 4-17
- *Page number is reset to 0 when reaching 99999999.*

Using Distribution

1 Load your originals.

2 Touch **Number Stamping**.

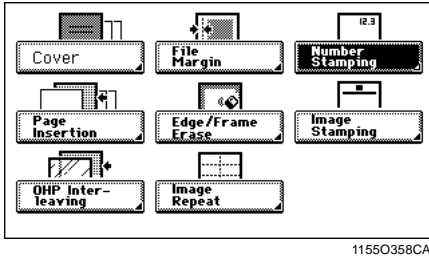

3 Touch **Distribution**.

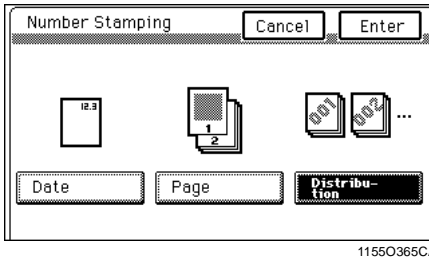

4 Enter the starting number from the 10-Key Pad.

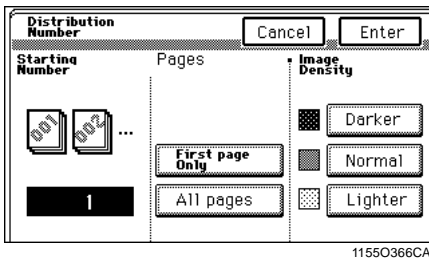

5 Select the page on which to print the distribution number, either **First page only** or **All pages**.

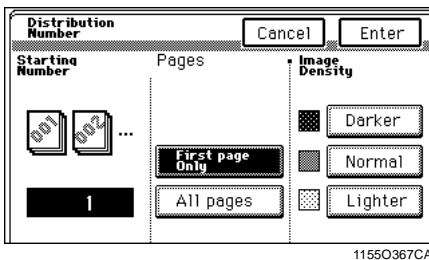

6 Select the image density, either Darker, Normal, or Lighter.

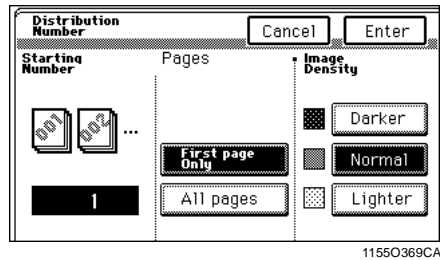

7 Touch **Enter**.

Useful Tip

The Distribution number is reset to 0 when reaching 999.

Image Stamping

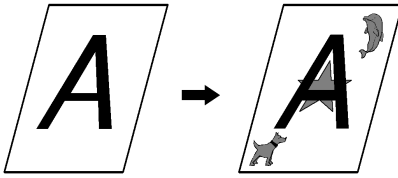

1155O553AA

Image Stamping lets you print a preprogrammed image at a specified location on the copy.

*The image can be printed at up to three places.

NOTE

Image Stamping is possible when the copier is equipped with an optional Hard Disk Drive Kit.

Checking the Preprogrammed Image

The preprogrammed image can be checked in advance.

1 Touch **Image Stamping**.

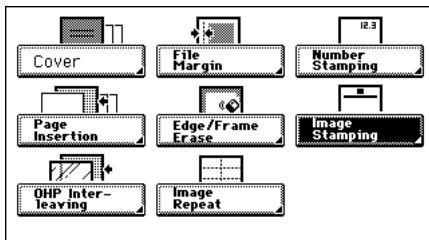

1155O368CA

2 Touch **Check** and select the image to be checked.

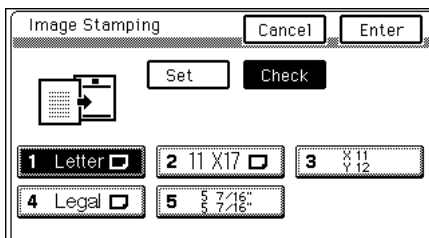

1155O371EA

3 Select the copy paper and press the Start key.

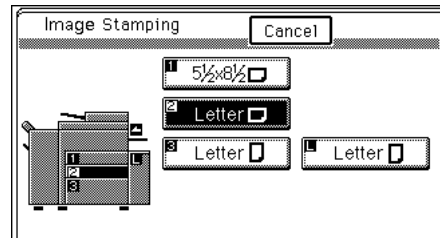

1155O373EB

NOTE

It is not possible to check the preprogrammed image if a job has been reserved.

Useful Tips

- A preprogrammed image can be stored in memory using Utility. *Image Memory Input.* (p. 4-8)
- A preprogrammed image can also be checked using Utility. *Checking Programmed Image.* (p. 4-11)

Calling Up a Preprogrammed Image

You may want to call up a preprogrammed image for use on the copy.

1 Load the originals.

2 Touch **Image Stamping**.

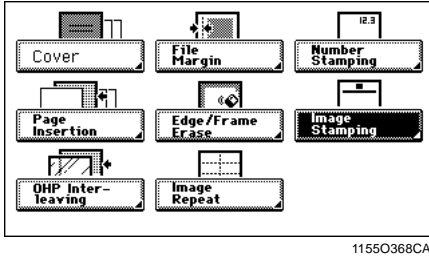

1155O368CA

3 Touch **Set** and select the desired image.

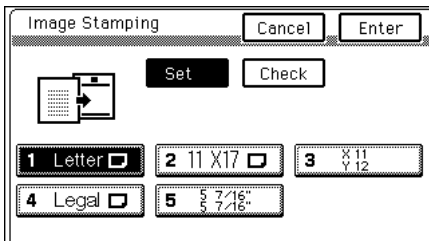

1155O375EA

4 Select the image stamping position.

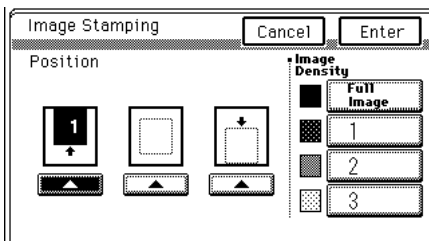

1155O376CA

5 Select the desired image density.

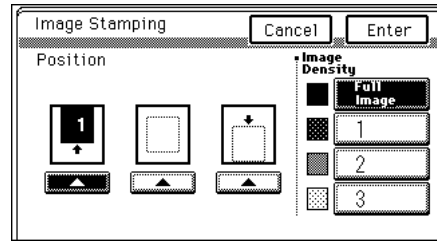

1155O377CA

6 Touch **Enter**.

7 Touch **Enter**.

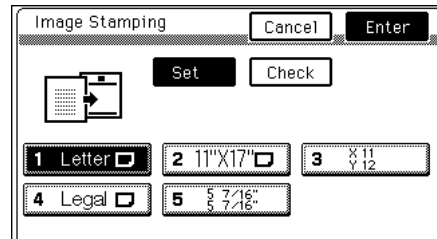

1155O379EA

NOTES

- If two or more images are used, each has to be different from the other and should be placed in a unique position. (No two images can be exactly the same.)
- When using Image Stamping, select the "Original Direction." [p. 3-37](#)

Useful Tip

Up to three preprogrammed images can be placed on the copy.

9. Selecting Mixed Orig. Detection and Other Functions

Mixed Orig. Detection and Other Functions

These pages explain about Mixed Original Detection and other document-related functions the copier offers. Pressing the Original key on the control panel shows a screen that allows you to set these functions.

- Touching either one of the four function keys highlights that particular key, which sets that function.
- Touching it a second time cancels the setting of that function.

Selecting Mixed Original Detection

Use the Mixed Original Detection function to make copies automatically from originals of assorted sizes loaded in the Electronic Document Handler.

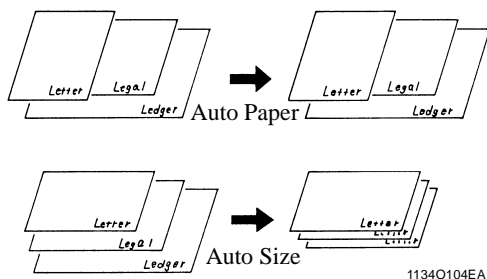

NOTE

<When FN-3 is mounted>

The copier cannot be used to make copies with Mixed Orig. Detection, Auto Paper, and Staple combined. It becomes, however, possible to make copies when Z-Fold is further combined with these three functions.

- 1 Load the stack of originals so that the rear edge of each original is pressed against the rear Document Guide Plate. Then, slide the front Document Guide Plate against the front edges of the originals with the greatest width.

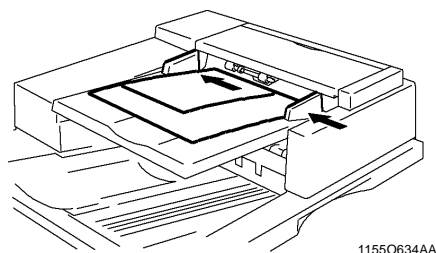

- 2 Touch the **Mixed Orig. Detection** key on the touch panel.

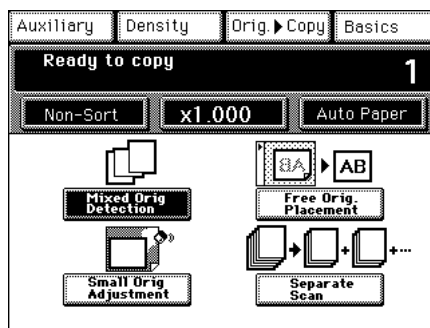

Useful Tip

User's Choice allows you to default to Mixed Original Detection. [p. 4-15](#)

Selecting Free Original Placement

Free Original Placement eliminates voids or image deviations on the copy even if the original is placed away from the Original Scales on the Original Glass.

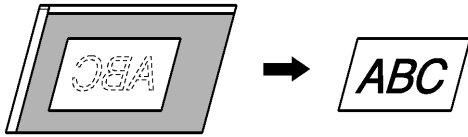

1155O554AA

1 Touch **Free Orig. Placement**.

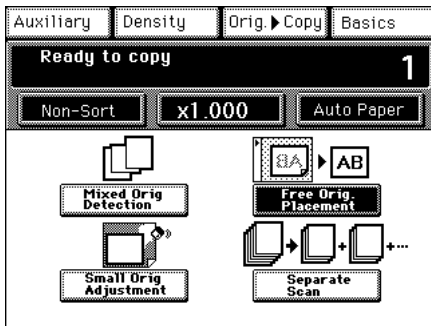

1155O381CB

NOTES

- Place the original in parallel with the Original Scales. The function does not work on an original placed askew.
- If the Realign Warning available from User's Choice is turned ON, the copier warns you of an original placed askew.
- The Realign Warning may fail to function properly to detect the correct original position for the following types of originals:
 - An original with a colored background
 - An original with images printed to the edges
 - An original that is not rectangular

Selecting Small Original Adjustment

When your original is smaller than the copy paper or when you are making a reduction copy, Small Original Adjustment prevents the areas outside the original from being dirtied on the copy.

You will not have a copy with black areas surrounding the image which is made with the Electronic Document Handler raised.

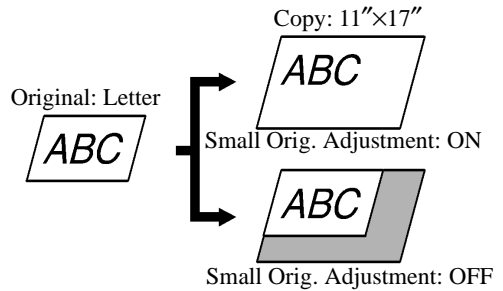

1155O555AA

1 Touch **Small Orig. Adjustment**.

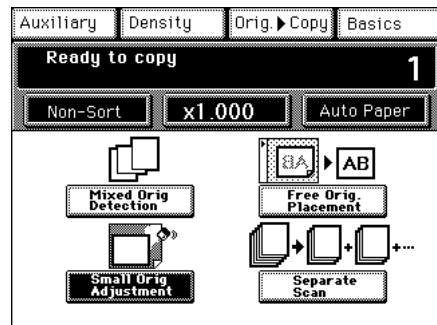

1155O382CB

NOTES

- Small Orig. Adjustment may fail to detect the correct position of the original, erasing part of the image, for the following types of originals:
 - An original with a colored background
 - An original with images printed to the edges
 - An original that is not rectangular
- The function can erase only a rectangular area even if the original is a complicated shape.



1155O646AA

Selecting Separate Scan

Separate Scan permits the copier to scan a large set of originals in several parts.

The Electronic Document Handler can be loaded with up to 100 pages of a document. If you, however, divide a document consisting of more than 100 pages so that each part contains less than 100 pages, it can still be scanned as one set by the copier.

Example: A 150-page document

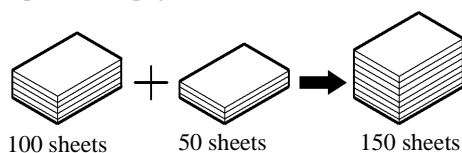

1155O556AA

1 Touch **Separate Scan**.

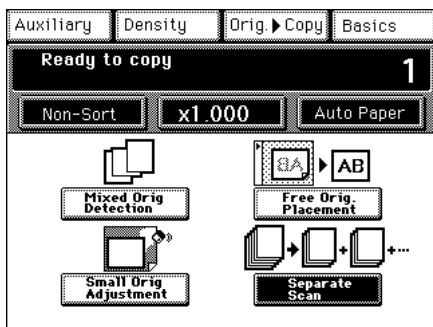

1155O383CB

2 Load the first set of original(s) and press the Start key.

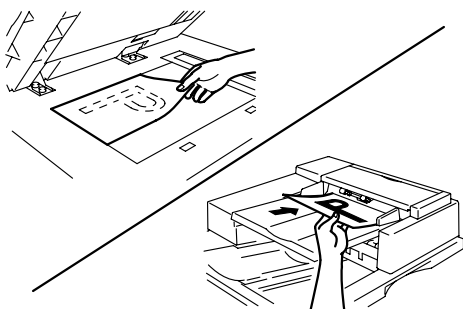

1155O757AA

NOTE

If the original is placed directly on the Original Glass to make a copy, do that in ascending order of page.

- 3 Load the next set of originals and press the Start key.
- 4 Repeat step 3 according to the number of pages of the document.

Useful Tip

The number of originals that can be scanned and stored in memory at one time is about 200 sheets of standard Letter paper. The addition of an optional 16MB Memory expands the maximum storage capacity to about 400 sheets and the addition of an optional Hard Disk Drive Kit expands it to about 500 sheets.

- 5 When all pages of the document have been scanned, touch **Finish** and press the Start key.

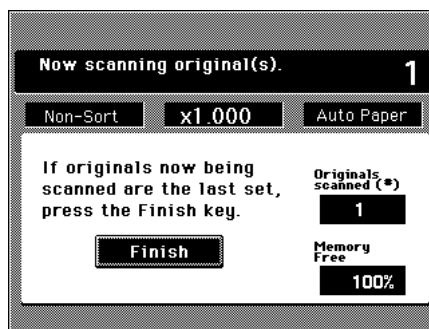

1155O384CA

- 6 The copier starts a print cycle.

10. Selecting the Job Functions

Memory Recall

After a print cycle has been completed, Memory Recall allows you to run another print cycle again using the same image data and copy settings as the previous one without having to reload the originals. After the first print cycle, touch **Memory Recall** on the Touch Panel to show a screen that allows you to make the necessary settings.

Setting Memory Recall

1 Touch **Memory Recall**.

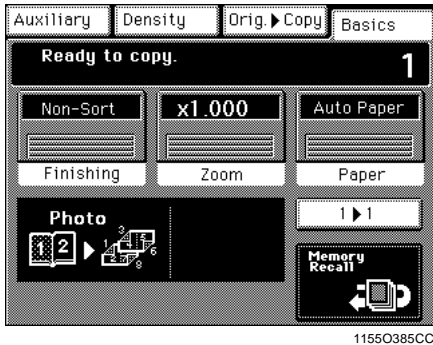

2 If you have any function to change, touch the corresponding mode key and make the necessary change.

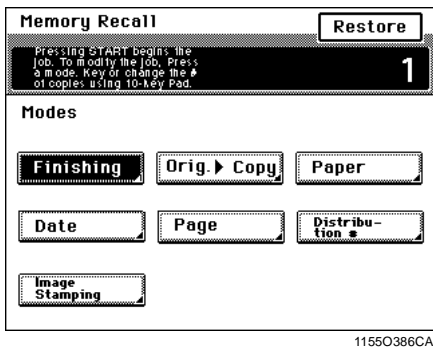

3 Press the Start key and the copier starts the print cycle.

NOTES

- Memory Recall available from User's Choice must be turned ON to use this function. *p. 4-15*
- This function cannot be used in the Interrupt mode.
- The preceding image data and copy settings are cleared to disable Memory Recall when any of the following operations are performed:
 - The copier is turned OFF.
 - The copier scans a new original or the Start key is pressed.
 - The Access key or Interrupt key is pressed, or Reserve is touched.
 - The **C** key or Panel Reset key is pressed while the copier remains idle.

Useful Tip

After you have made copies from a confidential document, it is recommended that you press the Panel Reset key to erase the data.

Useful Tips

- The following functions can be changed when running a print cycle again using Memory Recall:

• Finishing	• Orig. Copy
• Paper	• Date
• Page	• Distribution #
• Image Stamping	• No. of copies
- A pen mark  appears above the key of the function changed.
- To change the number of copies to be made, press the **C** key and set the new number.
- Paper size and direction cannot be changed.

Reserve

As the copier completes scanning for a regular copy job, it is capable of scanning for another job which is held in reserve. When the copier completes the print cycle for the first job, it automatically starts the print cycle for the reserved job.

*By job, we mean a sequence of operation from original loading to the end of the print cycle.

NOTE

“RESERVE” does not function when Date Controller/Key-Counter is installed to copier.

Reserving a Job

- 1 Touch **Reserve** on the Touch Panel.



NOTES

- Reserve is possible when the copier is equipped with an optional Hard Disk Drive Kit.
- The number of copier jobs that can be stored is a maximum of 5 or about 500 sheets of Letter standard original.
- Jobs are printed in order of reservation.
- For a job to be reserved, Manual Bypass cannot be selected.

- 2 Load the originals and make the necessary settings.

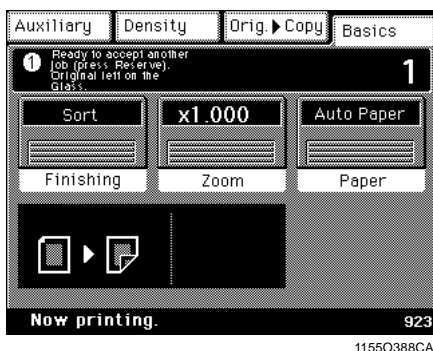

- 3 Press the Start key and the copier starts scanning the originals and the job is reserved.

10. Selecting the Job Functions

Job List

These pages explain about what convenient functions can be performed and settings made with the Job List key on the control panel. To use this function, press the Job List key.

Mode Check

Mode Check allows you to check what settings have been made for a job.

- 1 Touch **Mode Check** and then touch the job no. key whose settings are to be checked.

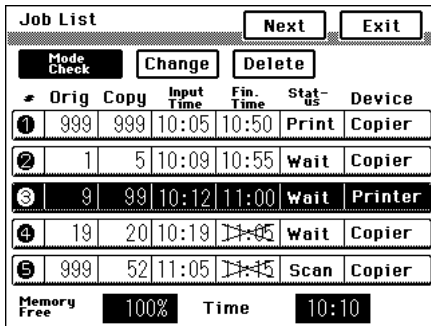

11550389CA

- 2 Touch **Next** or **Back Up** to check for the details of the settings.

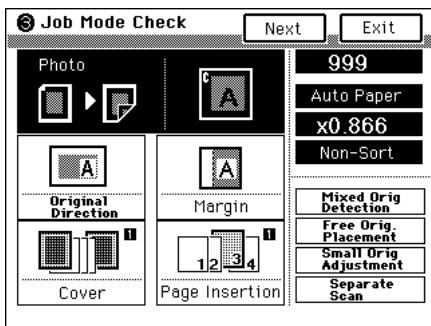

11550390CA

- 3 After the settings have been checked, touch **Exit**.

- 4 Touch **Exit** again.

Change

Change allows you to change the settings made for a job.

- 1 Touch **Change** and then touch the job no. key whose settings are to be changed.

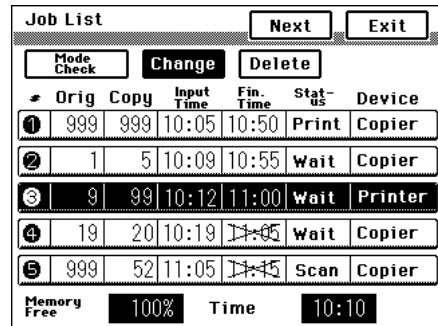

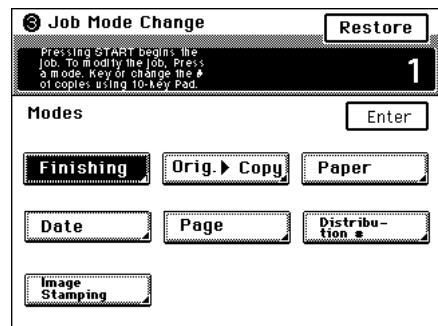

11550391CA

- 2 Select the desired function mode to be changed and touch **Enter**.



11550392CA

NOTES

- The following functions can be changed:
 - Finishing
 - Orig. Copy
 - Paper
 - Date
 - Page
 - Distribution #
 - No. of copies
 - Image Stamping
- A pen mark  appears above the key of the function changed.
- To change the number of copies to be made, press the  key and set the new number.

- 3 Touch **Enter**.

Delete

Delete allows you to delete a job previously set.

<To delete a job on the print queue>

- 1 Touch **Delete**.

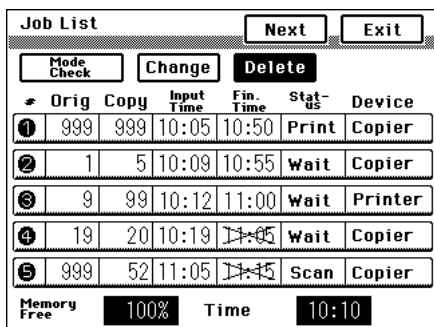

- 2 Touch the job no. key to be deleted.

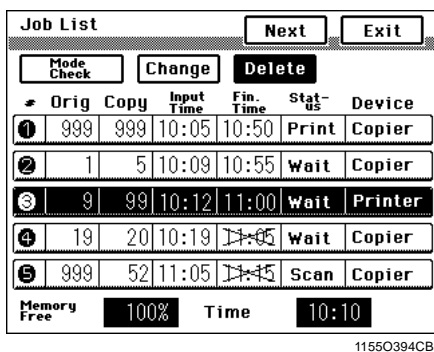

- 3 Touch **Yes**.

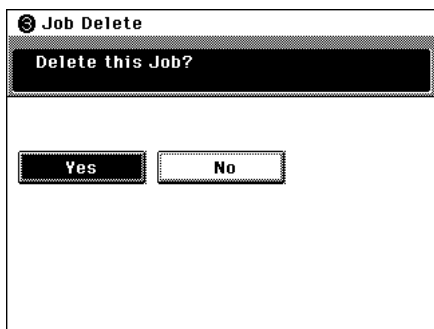

- 4 Touch **Exit**.

<To delete a job being scanned or printed>

- 1 Press the Stop key while the job in queue is being scanned or printed.

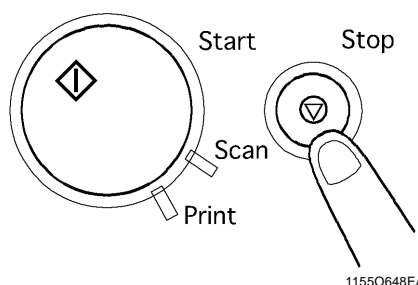

- 2 Touch **Delete Printing Job** or **Delete Scanning Job**.

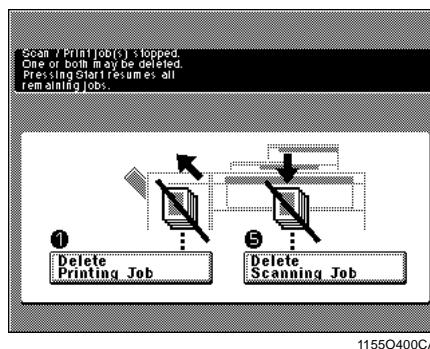

Useful Tip

Pressing the Stop key stops the scanning or printing action being performed.

- 3 Press the Start key.

10. Selecting the Job Functions

Unlock

A confidential document transmitted by a personal computer is unlocked when a password is entered, putting it in the print queue. A confidential document is identified with “Lock” in the status column.

- 1 Touch **Unlock**.

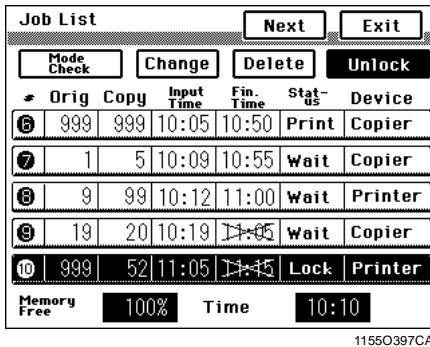

- 2 Enter a 4-digit password from the 10-Key Pad.

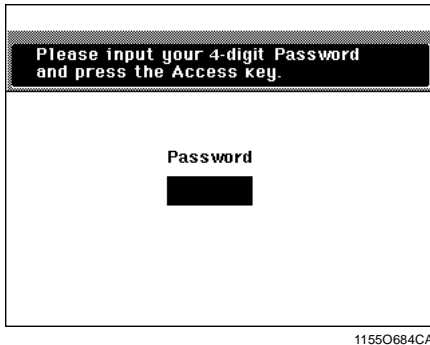

- 3 This unlocks the job, putting it in the print queue (status changes to “Wait”).

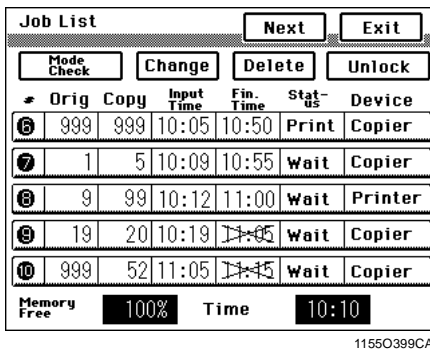

NOTES





- All jobs are unlocked if the password matches that entered.
- An unlocked job is placed at the end of the jobs on the print queue.

11. Typical Function Combinations

Making Different Types of Copy

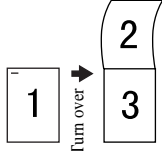
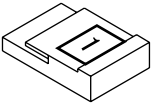
These pages explain about how to combine different functions to make various types of copy.

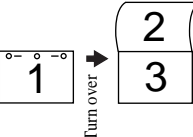
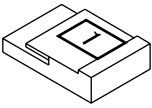
Reading the Table

	1	2	3	4	5	6	7	8
	Intended Type of Copy	Loading the Originals	Copy	Finishing Functions	Margin	File Margin	Select Position	
1 ▶ 2			2	— Corner Staple	—		—	
			2	Hole Punch 2-Point Staple	—	—		

- Shows whether the copy is 1-sided or 2-sided.
- Shows what type of copy you want to make.
- Shows how to load your original. ☞p. 3-4
- Shows which to set, either 1, 2, 2in1, or 4in1 for Original ▶ Copy. ☞p. 3-35
- Shows which to set, either Corner Staple, 2-Point Staple, or Hole-Punch for the finishing function. ☞p. 3-20
- Shows the margin position to be set for your original. ☞p. 3-38
- Shows the file margin function to be set as an auxiliary function. ☞p. 3-55
- Shows that the stapling position or hole punch positions must be set using the Select Position key. ☞p. 3-23, 3-24

*The marker “—” in the table indicates that no key setting is necessary.

11. Typical Function Combinations

Making Copies from 1-Sided Originals

	Intended Type of Copy	Loading the Originals	Copy	Finishing Functions	Margin	File Margin	Select Position
1			1	— Corner Staple	—	—	—
			1	— Corner Staple	—	—	—
			1	Hole Punch 2-Point Staple	—	—	—
			1	Hole Punch 2-Point Staple	—	—	
			1	— Corner Staple	—	—	—
			1	— Corner Staple	—	—	—
			1	Hole Punch 2-Point Staple	—	—	—
			1	Hole Punch 2-Point Staple	—	—	

11. Typical Function Combinations

	Intended Type of Copy	Loading the Originals	Copy	Finishing Functions	Margin	File Margin	Select Position
1 1			1[2in1]	— Corner Staple	—	—	—
			1[2in1]	— Corner Staple	—	—	—
			1[2in1]	Hole Punch 2-Point Staple	—	—	
			1[2in1]	Hole Punch 2-Point Staple	—	—	—
			1[2in1]	— Corner Staple	—	—	—
			1[2in1]	— Corner Staple	—	—	—
			1[2in1]	Hole Punch 2-Point Staple	—	—	—
			1[2in1]	Hole Punch 2-Point Staple	—	—	

11. Typical Function Combinations

Intended Type of Copy	Loading the Originals	Copy	Finishing Functions	Margin	File Margin	Select Position
		1[4in1]	—	—	—	—
			Corner Staple			
		1[4in1]	—	—	—	—
			Corner Staple			
		1[4in1]	Hole Punch	—	—	—
			2-Point Staple			
		1[4in1]	Hole Punch	—	—	
			2-Point Staple			
		1[4in1]	—	—	—	—
			Corner Staple			
		1[4in1]	—	—	—	—
			Corner Staple			
		1[4in1]	Hole Punch	—	—	—
			2-Point Staple			
		1[4in1]	Hole Punch	—	—	
			2-Point Staple			

11. Typical Function Combinations

	Intended Type of Copy	Loading the Originals	Copy	Finishing Functions	Margin	File Margin	Select Position
1 2			2	— Corner Staple	—	—	—
			2	— Corner Staple	—		—
			2	Hole Punch 2-Point Staple	—	—	—
			2	Hole Punch 2-Point Staple	—	—	
			2	— Corner Staple	—		—
			2	— Corner Staple	—	—	—
			2	Hole Punch 2-Point Staple	—		—
			2	Hole Punch 2-Point Staple	—	—	

11. Typical Function Combinations

	Intended Type of Copy	Loading the Originals	Copy	Finishing Functions	Margin	File Margin	Select Position
1 2			2[2in1]	— Corner Staple	—		—
			2[2in1]	— Corner Staple	—	—	—
			2[2in1]	Hole Punch 2-Point Staple	—	—	
			2[2in1]	Hole Punch 2-Point Staple	—	—	—
			2[2in1]	— Corner Staple	—	—	—
			2[2in1]	— Corner Staple	—		—
			2[2in1]	Hole Punch 2-Point Staple	—	—	—
			2[2in1]	Hole Punch 2-Point Staple	—	—	

11. Typical Function Combinations

	Intended Type of Copy	Loading the Originals	Copy	Finishing Functions	Margin	File Margin	Select Position
1 2			2[4in1]	— Corner Staple	—	—	—
			2[4in1]	— Corner Staple	—		—
			2[4in1]	Hole Punch 2-Point Staple	—	—	—
			2[4in1]	Hole Punch 2-Point Staple	—	—	
			2[4in1]	— Corner Staple	—		—
			2[4in1]	— Corner Staple	—	—	—
			2[4in1]	Hole Punch 2-Point Staple	—		—
			2[4in1]	Hole Punch 2-Point Staple	—	—	

11. Typical Function Combinations

Making Copies from 2-sided Originals to be Stapled on Left Edge

	Intended Type of Copy	Loading the Originals	Copy	Finishing Functions	Margin	File Margin	Select Position
2 ↑ 1			1	— Corner Staple	—	—	—
			1	— Corner Staple	—	—	—
			1	Hole Punch 2-Point Staple	—	—	—
			1	Hole Punch 2-Point Staple	—	—	
			1	— Corner Staple		—	—
			1	— Corner Staple		—	—
			1	Hole Punch 2-Point Staple		—	—
			1	Hole Punch 2-Point Staple		—	











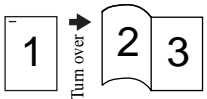
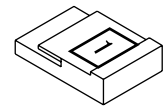
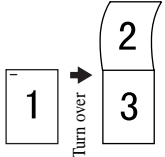
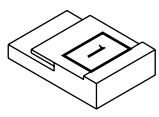

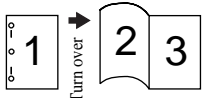
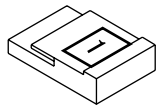
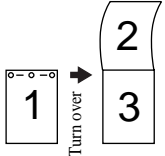
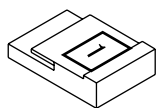
11. Typical Function Combinations

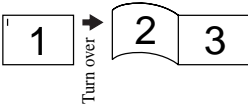
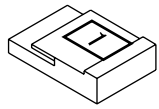
	Intended Type of Copy	Loading the Originals	Copy	Finishing Functions	Margin	File Margin	Select Position
2 1			1[2in1]	— Corner Staple	—	—	—
			1[2in1]	— Corner Staple	—	—	—
			1[2in1]	Hole Punch 2-Point Staple	—	—	
			1[2in1]	Hole Punch 2-Point Staple	—	—	—
			1[2in1]	— Corner Staple		—	—
			1[2in1]	— Corner Staple		—	—
			1[2in1]	Hole Punch 2-Point Staple		—	—
			1[2in1]	Hole Punch 2-Point Staple		—	

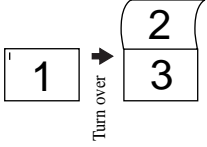
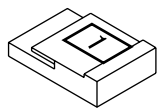
11. Typical Function Combinations

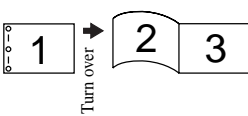
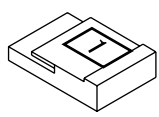
	Intended Type of Copy	Loading the Originals	Copy	Finishing Functions	Margin	File Margin	Select Position
2 ↑ 1			1[4in1]	— Corner Staple	—	—	—
			1[4in1]	— Corner Staple	—	—	—
			1[4in1]	Hole Punch 2-Point Staple	—	—	—
			1[4in1]	Hole Punch 2-Point Staple	—	—	
			1[4in1]	— Corner Staple		—	—
			1[4in1]	— Corner Staple		—	—
			1[4in1]	Hole Punch 2-Point Staple		—	—
			1[4in1]	Hole Punch 2-Point Staple		—	

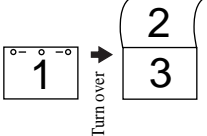
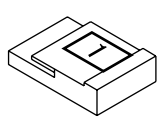
11. Typical Function Combinations

	Intended Type of Copy	Loading the Originals	Copy	Finishing Functions	Margin	File Margin	Select Position
2 2			2	— Corner Staple	—	—	—
			2	— Corner Staple	—		—
			2	Hole Punch 2-Point Staple	—	—	—
			2	Hole Punch 2-Point Staple	—	—	
			2	— Corner Staple			—
			2	— Corner Staple		—	—
			2	Hole Punch 2-Point Staple			—
			2	Hole Punch 2-Point Staple		—	

11. Typical Function Combinations









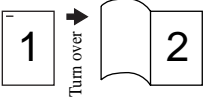
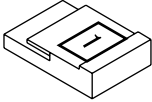

	Intended Type of Copy	Loading the Originals	Copy	Finishing Functions	Margin	File Margin	Select Position
2 2			2[2in1]	— Corner Staple	—		—
			2[2in1]	— Corner Staple	—	—	—
			2[2in1]	Hole Punch 2-Point Staple	—	—	
			2[2in1]	Hole Punch 2-Point Staple	—	—	—
			2[2in1]	— Corner Staple		—	—
			2[2in1]	— Corner Staple			—
			2[2in1]	Hole Punch 2-Point Staple		—	—
			2[2in1]	Hole Punch 2-Point Staple		—	

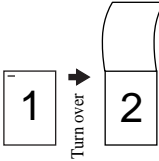
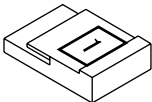
11. Typical Function Combinations

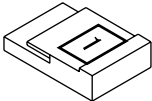
	Intended Type of Copy	Loading the Originals	Copy	Finishing Functions	Margin	File Margin	Select Position
2 2			2[4in1]	— Corner Staple	— —	—	—
			2[4in1]	— Corner Staple	—		—
			2[4in1]	Hole Punch 2-Point Staple	—	—	—
			2[4in1]	Hole Punch 2-Point Staple	—	—	
			2[4in1]	— Corner Staple			—
			2[4in1]	— Corner Staple		—	—
			2[4in1]	Hole Punch 2-Point Staple			—
			2[4in1]	Hole Punch 2-Point Staple		—	

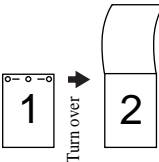
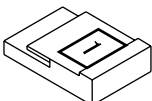
11. Typical Function Combinations

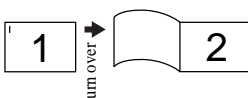
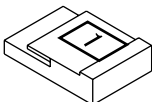
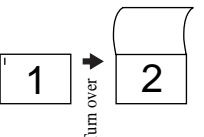
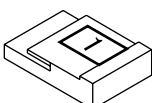
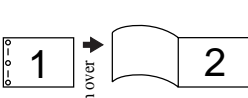
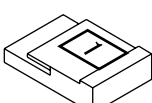
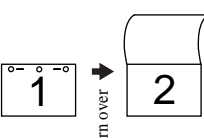
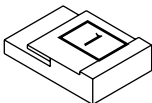
Making Copies from 2-sided Originals to be Stapled on Top Edge

	Intended Type of Copy	Loading the Originals	Copy	Finishing Functions	Margin	File Margin	Select Position
2 ↑ 1			1	— Corner Staple		—	—
			1	— Corner Staple		—	—
			1	Hole Punch 2-Point Staple		—	—
			1	Hole Punch 2-Point Staple		—	
			1	— Corner Staple	—	—	—
			1	— Corner Staple	—	—	—
			1	Hole Punch 2-Point Staple	—	—	—
			1	Hole Punch 2-Point Staple	—	—	

11. Typical Function Combinations

	Intended Type of Copy	Loading the Originals	Copy	Finishing Functions	Margin	File Margin	Select Position
2 1			1[2in1]	— Corner Staple			—
			1[2in1]	— Corner Staple		—	—
			1[2in1]	Hole Punch 2-Point Staple		—	
			1[2in1]	Hole Punch 2-Point Staple		—	—
			1[2in1]	— Corner Staple	—	—	—
			1[2in1]	— Corner Staple	—	—	—
			1[2in1]	Hole Punch 2-Point Staple	—		—
			1[2in1]	Hole Punch 2-Point Staple	—	—	

11. Typical Function Combinations

	Intended Type of Copy	Loading the Originals	Copy	Finishing Functions	Margin	File Margin	Select Position
2 1			1[4in1]	— Corner Staple		—	—
			1[4in1]	— Corner Staple		—	—
			1[4in1]	Hole Punch 2-Point Staple		—	—
			1[4in1]	Hole Punch 2-Point Staple		—	
			1[4in1]	— Corner Staple	—	—	—
			1[4in1]	— Corner Staple	—	—	—
			1[4in1]	Hole Punch 2-Point Staple	—	—	—
			1[4in1]	Hole Punch 2-Point Staple	—	—	

11. Typical Function Combinations

	Intended Type of Copy	Loading the Originals	Copy	Finishing Functions	Margin	File Margin	Select Position
2 2			2	— Corner Staple	— 	—	—
			2	— Corner Staple	 		—
			2	Hole Punch 2-Point Staple		—	—
			2	Hole Punch 2-Point Staple		—	
			2	— Corner Staple	—		—
			2	— Corner Staple	—	—	—
			2	Hole Punch 2-Point Staple	—		—
			2	Hole Punch 2-Point Staple	—	—	

11. Typical Function Combinations

	Intended Type of Copy	Loading the Originals	Copy	Finishing Functions	Margin	File Margin	Select Position
2 2			2[2in1]	— Corner Staple			—
			2[2in1]	— Corner Staple		—	—
			2[2in1]	Hole Punch 2-Point Staple		—	
			2[2in1]	Hole Punch 2-Point Staple		—	—
			2[2in1]	— Corner Staple	—	—	—
			2[2in1]	— Corner Staple	—		—
			2[2in1]	Hole Punch 2-Point Staple	—	—	—
			2[2in1]	Hole Punch 2-Point Staple	—	—	

11. Typical Function Combinations

	Intended Type of Copy	Loading the Originals	Copy	Finishing Functions	Margin	File Margin	Select Position
2 2			2[4in1]	— Corner Staple		—	—
			2[4in1]	— Corner Staple			—
			2[4in1]	Hole Punch 2-Point Staple		—	—
			2[4in1]	Hole Punch 2-Point Staple		—	
			2[4in1]	— Corner Staple	—		—
			2[4in1]	— Corner Staple	—	—	—
			2[4in1]	Hole Punch 2-Point Staple	—		—
			2[4in1]	Hole Punch 2-Point Staple	—	—	

11. Typical Function Combinations

Precautions When Making Copies on 11"×17"L or LegalL

When making copies on 11"×17"L or LegalL, make sure of the correct direction of the original, position of 2-point staple, and position of hole-punch.

If you load your original as shown below, select  as part of your steps to specify the Direction of Original.

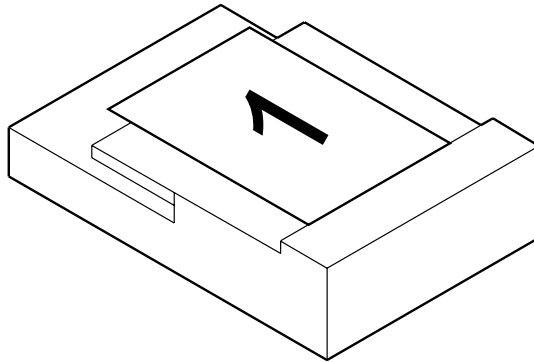

1155O843AA

When making copies on 11"×17"L or LegalL, 2-point staple or hole punch cannot be made in any of the following positions.

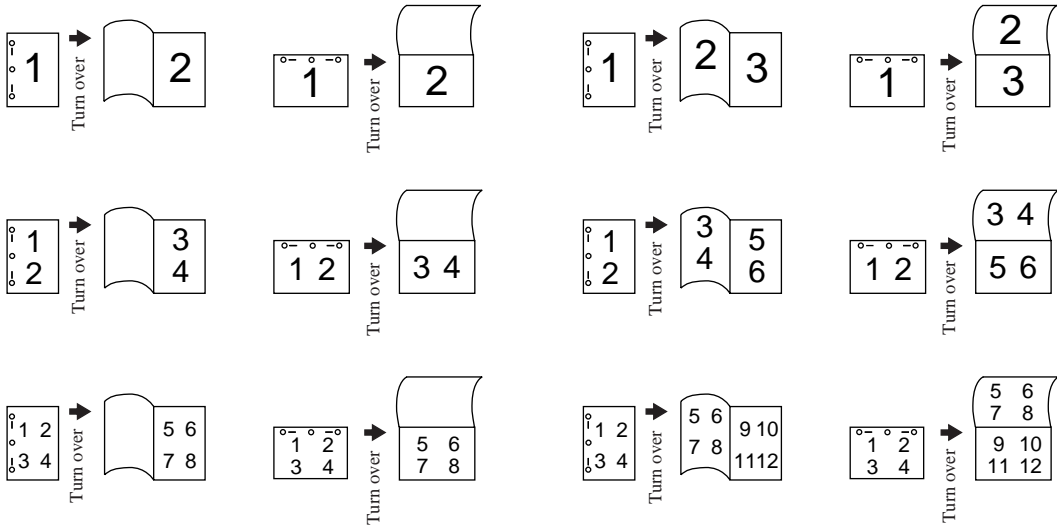

1155O882EA

Chapter 4

Using the Utility Mode

1. Job Memory Input and Job Recall

Job Memory Input

Up to 10 different, frequently used copy job programs can be stored in memory and recalled later as necessary. When the copier is equipped with an optional Hard Disk Drive Kit and if “100 Accounts” is selected for “Copy Track” of “Administrator Mode” available from User's Choice, up to 10 different jobs can be stored in memory for each account.

Storing a Job

- 1 Set up the job you want to store in memory.
- 2 Press the Utility key.
- 5 Select any one of the 10 job number keys from **1** to **10** marked with  .

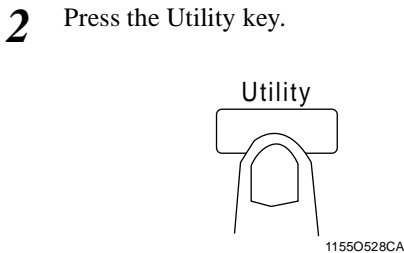

- 3 Touch **Job/Zoom mem. Input** .

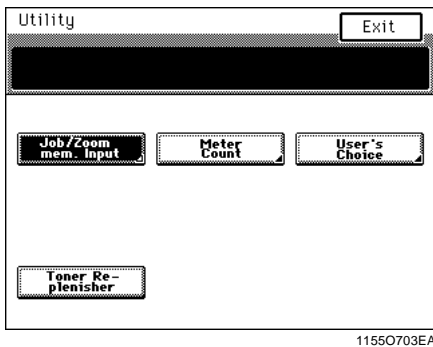

- 4 Touch **Job Memory Input** .

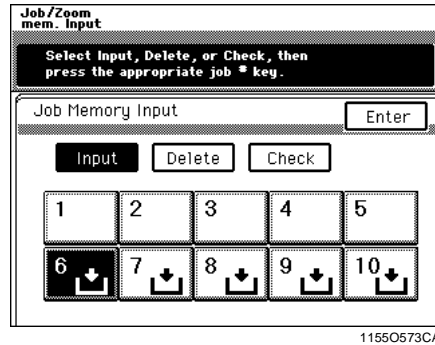
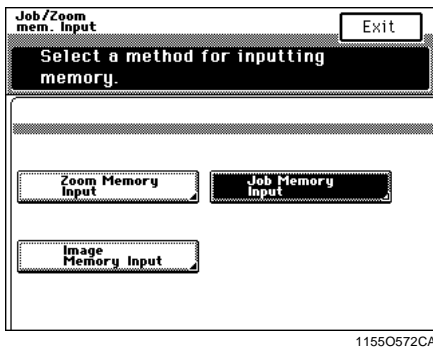

NOTE

A job number key not marked with  indicates that a job has already been stored under that number. If you store a new job in that number key, the old job is erased.

- 6 To check for the details of the job stored, touch **Check** and then touch the job number key.

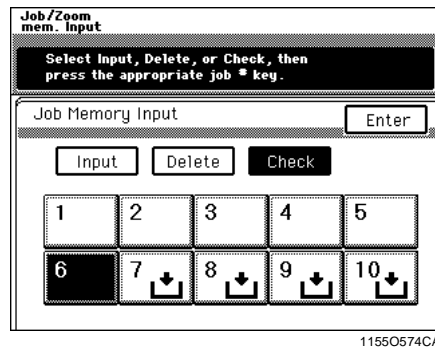

The job settings appear on the Touch Panel.

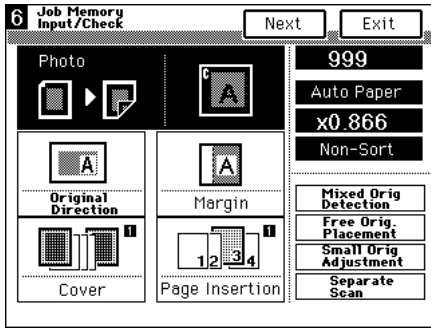

1155O575CA

7 After you have checked the settings, touch **Exit**.

8 Touch **Enter**.

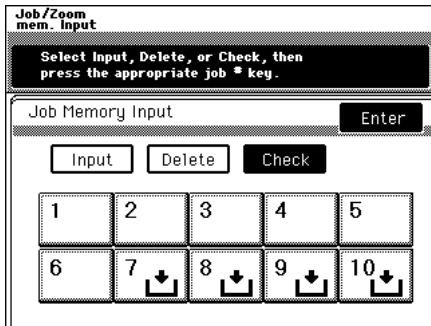

1155O576CA

1. Job Memory Input and Job Recall

Deleting a Job Program

1 Press the Utility key.

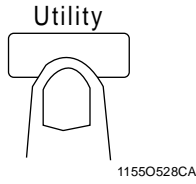

2 Touch **Job/Zoom mem. Input**.

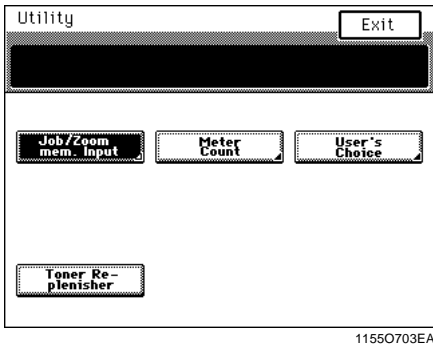

3 Touch **Job Memory Input**.

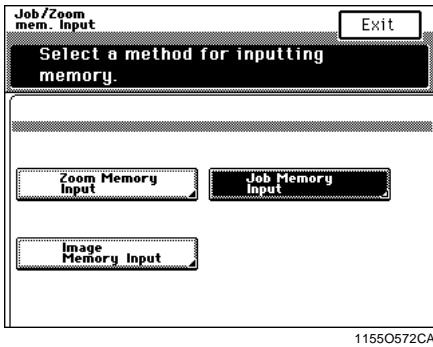

4 Touch **Delete**, then touch the job number key from which you want to delete a job program.

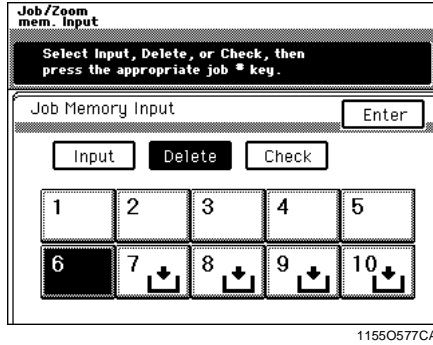

When  appears in that key, it indicates that the job program has been deleted.

5 Touch **Enter**.

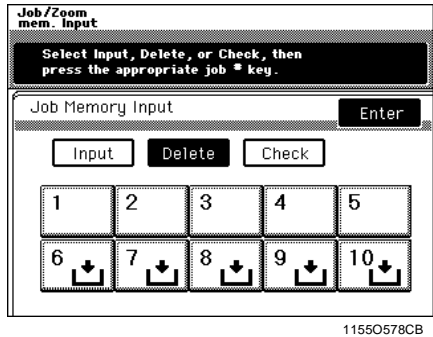

Recalling a Job from Memory

- 1 Press the Job Recall key.

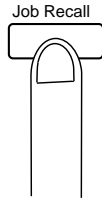

1134P365CA

- 2 Touch the job number key in which the desired job has been stored.

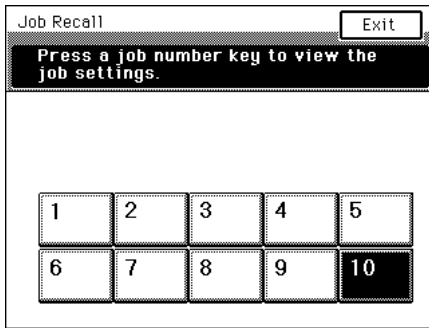

1155O579CB

- 3 Check the settings made and then touch **Exit**. The copier is set up for these settings and the Basics screen reappears.

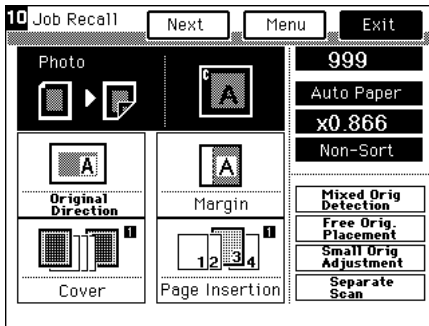

1155O580CA

If the job recalled is not what you want, touch **Menu**. Then, the Job Recall screen reappears.

2. Zoom Memory Input

Up to two different, frequently used zoom ratios can be stored in memory so you can use them later whenever necessary. For the **Mini Redu** ratio, $\times 0.930$ has been factory-set, but that can be changed as necessary. When the copier is equipped with an optional Hard Disk Drive Kit and if “100 Accounts” is selected for “Copy Track” of “Administrator Mode” available from User's Choice, zoom ratios can be stored in memory for each account.

Storing a Zoom Ratio

1 Press the Utility key.

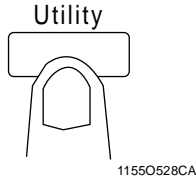

2 Touch **Job/Zoom mem. Input**.

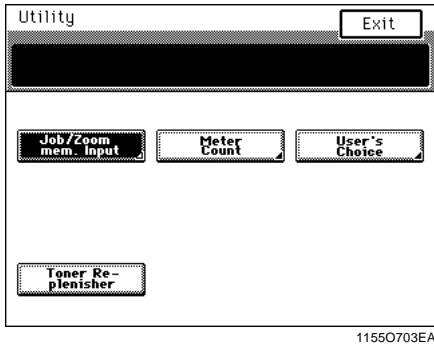

3 Touch **Zoom Memory Input**.

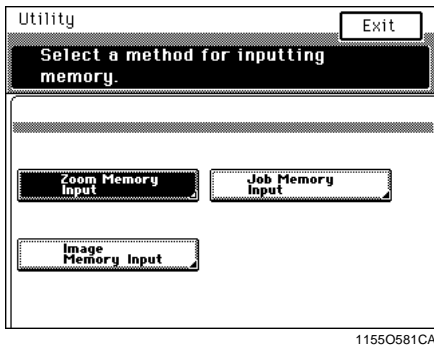

4 Using the 10-Key Pad, enter the desired zoom ratio.

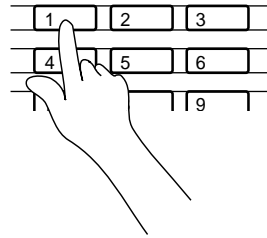

Useful Tips

- For example, enter $\times 1.234$ as **1**, **2**, **3**, and **4**, in that order.



- To correct an entry, press the **C** key, then enter the new ratio.
- The zoom ratio can range from $\times 0.250 \sim \times 4.000$.
- The **Mini Redu** ratio can range between $\times 0.900 \sim \times 0.999$.

5 Touch the desired number key in which you want to store the zoom ratio, either **1** or **2**. When the zoom ratio is properly stored in the number key, the ratio appears on the number key.

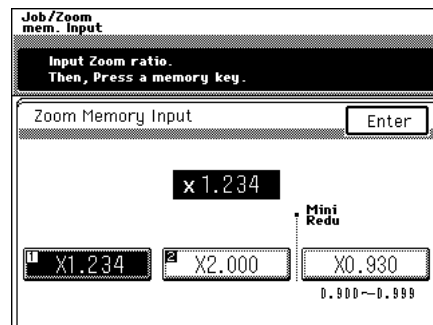

NOTE

When a new zoom ratio is stored in a key number, the old one stored in that key number is lost.

6 Touch **Enter** .

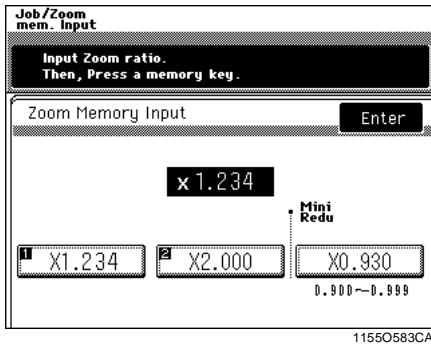
**Useful Tips**

- A zoom ratio using X/Y Zoom can be stored in memory on the screen with which to recall a X/Y Zoom ratio.
Storing a Ratio in Memory ↗ p. 3-19
- Custom Zoom may also be used to store a zoom ratio.
Storing a Ratio in Memory ↗ p. 3-18

3. Image Memory Input

Image Memory Input

Up to five different, frequently used characters and marks can be stored in memory so you can use them later whenever necessary. This function is possible when the copier is equipped with a Hard Disk Drive Kit.

Storing an Image

- 1 Press the Utility key.

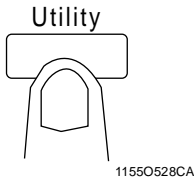

- 2 Touch **Job/Zoom mem. Input**.

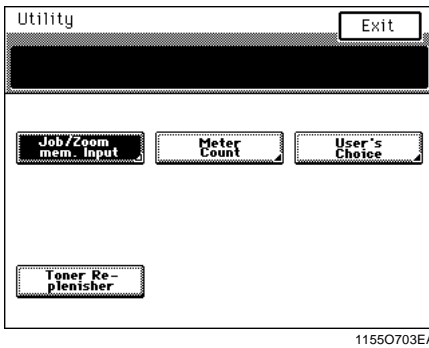

- 3 Touch **Image Memory Input**.

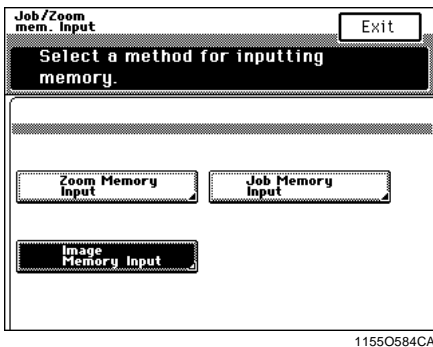

- 4 Touch **Input**, then touch the desired image number key, in which you want to store the image.

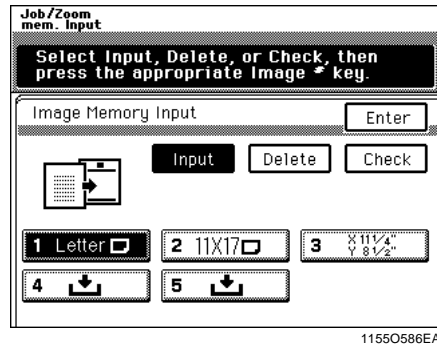

NOTE

An image number key not marked with  indicates that an image has already been stored under that number. If you store a new image in that number key, the old image is erased.

- 5 Select the size of the original, from which to store an image.

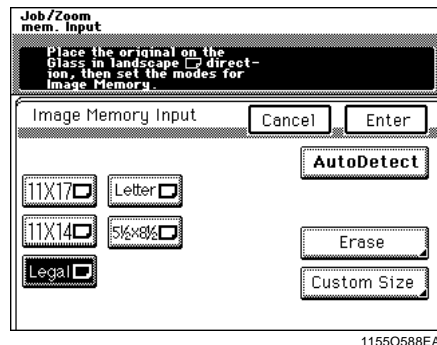

3. Image Memory Input

<Auto size detection>

- Touch **AutoDetect** on the screen given in step 5.

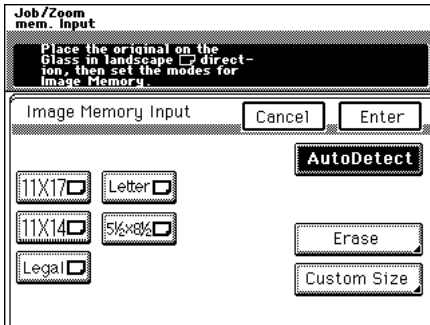



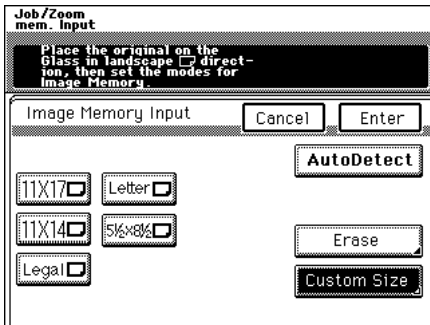

1155O590EA

<Size input>

- Touch **Custom Size** on the screen given in step 5.



1155O592EA

- Touch  or  to set the whole number for X and touch the **X** key. The underline moves to the right. Then touch  or  to set the fractional number and touch the **X** key. Now the value for X has been fixed.

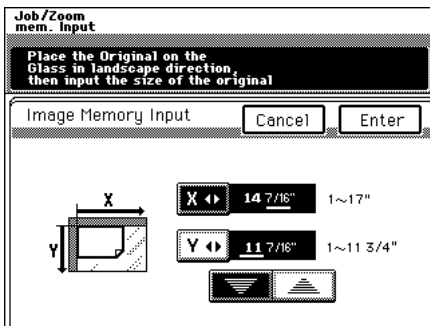

1155O594EA

- Do the same for Y, then touch **Enter**.

- 6 If you want to erase the image on the left, top, or along the frame of the original, touch **Erase**.

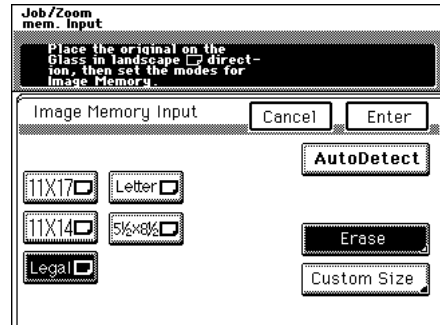

1155O596EA

You have a choice of the following three types of erase:

- Left edge erase 

Stores the image after erasing the left edge of the original.

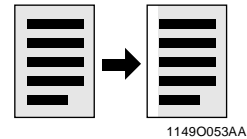

1149O053AA

- Top edge erase 

Stores the image after erasing the top edge of the original.

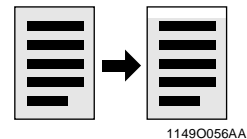

1149O056AA

- Frame erase 

Stores the image after erasing the four edges of the original.

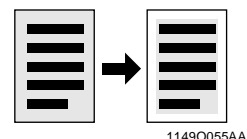

1149O055AA

3. Image Memory Input

7 Select the desired erase position.

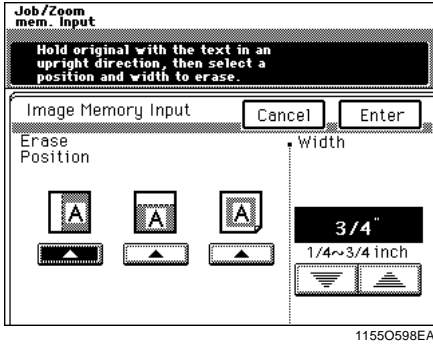

11550598EA

8 Using the or key, set the desired erase width.

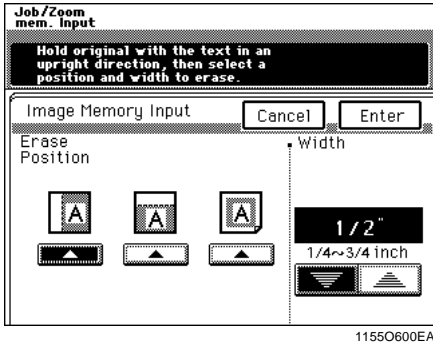

11550600EA

11 As illustrated on the Touch Panel, place the original directly on the Original Glass.

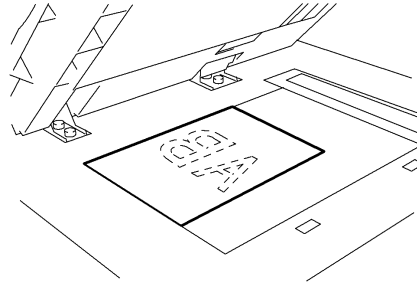

11550557AA

12 Select an image orientation the same as that of the original.

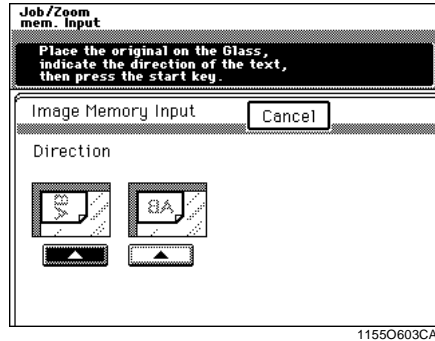

11550603CA

13 Press the Start key.

Useful Tip
The erase width can range between 1/4" ~ 3/4" variable in /16" increments.

9 Touch **Enter**.

10 Touch **Enter**.

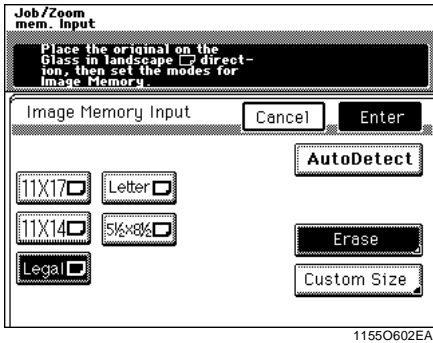

11550602EA

Checking the Programmed Image

- 1 Press the Utility key.

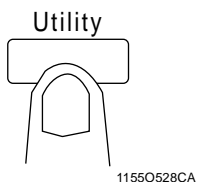

- 2 Touch **Job/Zoom mem. Input**.

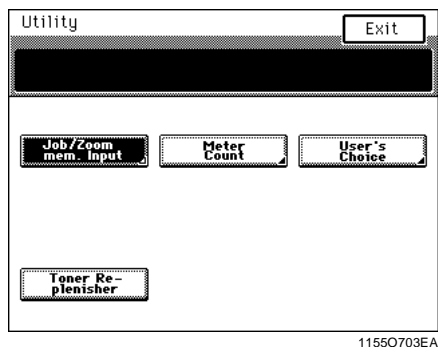

- 3 Touch **Image Memory Input**.

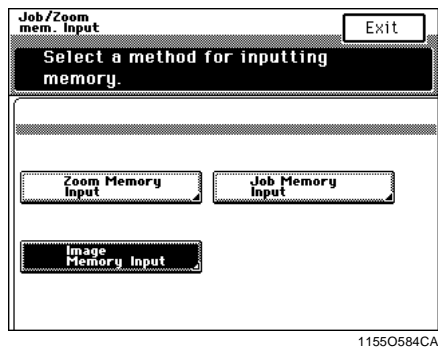

- 4 Touch **Check**, then touch the number key to be checked.

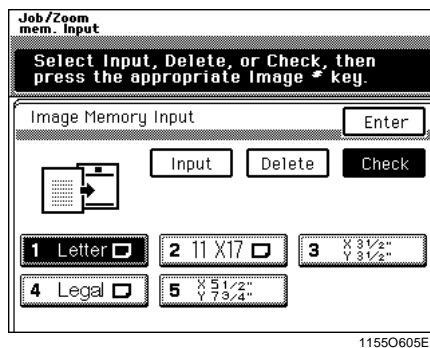

- 5 Select the copy paper.

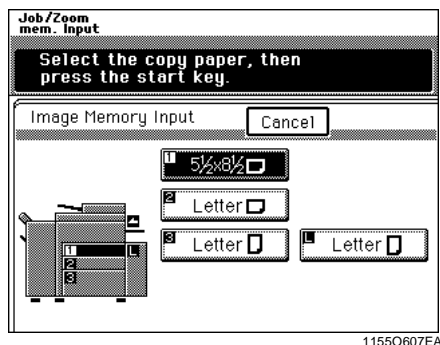

- 6 Press the Start key and the programmed image is printed on the copy.

Useful Tip

Programmed images may be checked by using the screen for calling up a preprogrammed image.

Checking the Preprogrammed Image p. 3-65

3. Image Memory Input

Deleting a Programmed Image

1 Press the Utility key.

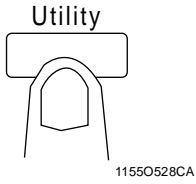

2 Touch **Job/Zoom mem. Input**.

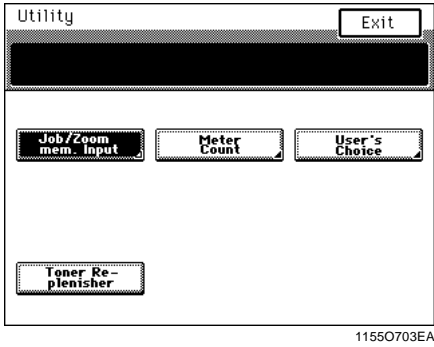

3 Touch **Image Memory Input**.

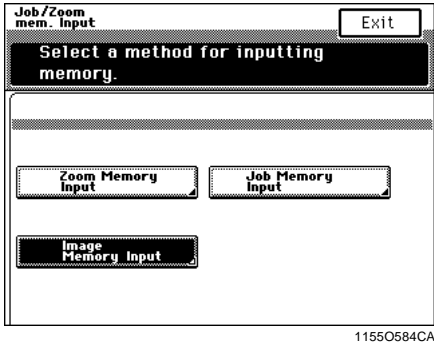

4 Touch **Delete**, then touch the number key to be deleted.

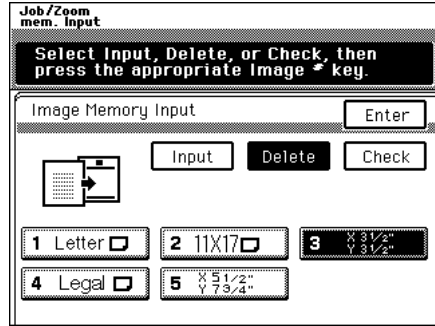

5 Touch **Enter**.

4. Meter Count and Toner Replenisher

Meter Count

Touching **Meter Count** allows you to check the total count of each of the following seven counters.

Total Counter

Shows the total number of copies made since the installation of the copier.

Size Counter

Shows the number of copies made on copy paper of a preset size. (The size will be set by your Tech. Rep.)

2-Sided Total

Shows the number of 2-sided copies made.

2-Sided Size

Shows the number of 2-sided copies made on copy paper of a preset size (the same size as set for Size Counter).

Account Total

Shows the total number of copies made by the active accounts.

Printer Total Counter

Shows the total number of prints produced by the copier configured as a printer.

Printer Size Counter

Shows the number of prints produced by the copier configured as a printer on paper of a size preset for Size Counter.

Toner Replenisher

Touching **Toner Replenisher** sets the copier into the auxiliary toner replenishing mode. The copier tends to exhaust the supply of toner rapidly when making a number of copies from an original with dark solid areas such as a photo. As a result, the image density of the copy will become lighter. In such a case, you can use Toner Replenisher to regain the normal image density quickly.

NOTES

- Do not turn OFF the Power Switch or open the Front Door while the copier is replenishing toner.
 - Toner is not replenished if the image density is sufficiently high.
 - The toner replenishing sequence ends automatically.
-

5. User's Choice

The copier has been set so that the most frequently used settings are automatically selected in the initial mode. User's Choice allows you to select the default settings which are automatically selected in the initial mode according to your own needs. By setting defaults that are most frequently used, time and effort to make extra settings will be eliminated when the copier is turned ON or when Auto Panel Reset is activated.

User's Choice Functions

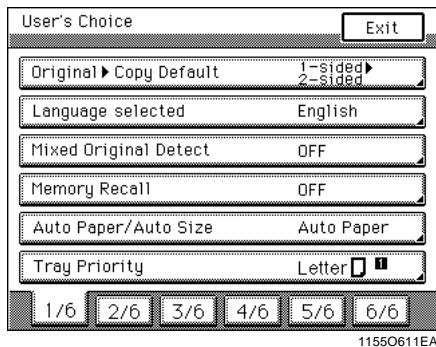

A listing of User's Choice functions is given in six pages of menu, from **1/6** to **6/6**. To show the listing of each page, touch the desired page number key at the bottom of the Touch Panel.

1/6 ⇨ p. 4-15

Original ▶ Copy Default

Language Selected

Mixed Original Detect

Memory Recall

Auto Paper/Auto Size

Tray Priority

2/6 ⇨ p. 4-16

2in1, 4in1, Booklet Copy Zoom

Exposure Priority

Default Level

Output Priority

Intelligent Sorting

Criss Cross Mode

3/6 ⇨ p. 4-17

Realign Warning

“Small” Originals

4in1 Copy Order

Date Printing Format

Date Printing Position

Page Number Position

4/6 ⇨ p. 4-18

Confirmation Beep

5/6 ⇨ p. 4-18

Universal Tray

Special Paper

Auto Panel Reset

Energy Save Mode

Plug-in Counter Reset

Auto Shut OFF

6/6 ⇨ p. 4-19

Date/Time Set

Print Exposure

Priority Device

Density (ADF)

Priority Offset Tray

Administrator Mode

Useful Tips

- When “100 Accounts” is selected, the User's Choice functions of **1/6** to **4/6** can be set for each account after the corresponding access code has been entered. Note, however, that when “100 Accounts” is selected, the listing of User's Choice displayed on the Touch Panel is from **1/4** to **4/4**.
- The administrator can make the User's Choice settings in common with all 100 accounts after “100 Accounts” has been selected.
 - ① With the Touch Panel prompting you to enter the access code, press the **Utility** key.
 - ② Touch **User's Choice**.
 - ③ Enter the administrator number from the 10-Key Pad.

*This allows the administrator to make the settings for **1/6** to **6/6**.

NOTE

The User's Choice settings in common with 100 accounts for **1/6** to **4/6** are not valid for the accounts for which the individual User's Choice settings have been made after “100 Accounts” was selected.

1/6

Original ► Copy Default

Specify the original ► copy type automatically selected when power is turned ON or panel reset.

The initial setting is 1-Sided ► 2-Sided.

Consult your Technical Representative if you want to change the setting to 1-Sided ► 1-Sided.

Language Selected

Select the language of the Touch Panel messages.

The initial setting is “English.”

Mixed Original Detect

Select whether to default to Mixed Original Detection (“ON”) or not (“OFF”) when power is turned ON or panel reset.

The initial setting is “OFF.”

* If the following combination is set at a time in User's Choice, the Mixed Orig. Detect will be automatically canceled and the copies are made in 1 ► 2 copy mode.

- Original ► Copy Default: 1-sided ► 2-sided
- Mixed Orig. Detect: ON

Memory Recall

Select whether to enable (“ON”) the function that allows you to use the same image data of the copy cycle that has just been completed or not (“OFF”).

The initial setting is “OFF.”

Auto Paper/Auto Size

Specify the default mode selected automatically when power is turned ON or panel reset, either “Auto Paper,” “Auto Size,” or “Manual.”

The initial setting is “Auto Paper.”

Tray Priority

Specify the default paper source that is automatically selected.

The initial setting is “1” (1st Drawer).

2in1, 4in1, Booklet Copy Zoom

Select whether to enable (“ON”) or disable (“OFF”) recalling a default zoom ratio for 2in1, 4in1, or Booklet Creation. Setting is possible for “2in1/4in1” and “Booklet Creation.”

- “2in1/4in1”

Default zoom ratios:

2in1: 0.647

4in1: 0.500

The initial setting is “ON.”

- “Booklet Creation”

Default zoom ratio:

Booklet Creation: 0.647

The initial setting is “ON.”

Exposure Priority

Select the default exposure mode selected automatically when power is turned ON or panel reset, either “Auto Exposure” or “Manual.”

The initial setting is “Auto Exposure.”

Default Level

Auto

Select the default exposure level in the Auto Exposure mode, either “Lighter,” “Normal,” or “Darker.”

The initial setting is “Normal.”

Manual

Set the default exposure level in the Manual Exposure mode.

The initial setting is “5.”

*With EXP5 at the central level, the exposure level will become lower as the number becomes smaller, and it will become higher as the number becomes greater.

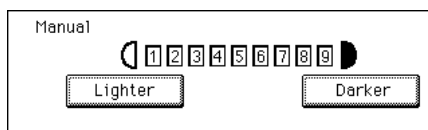

11550885CA

Output Priority

Select the default finishing type when the copier is equipped with a Finisher from among the following: Non-Sort, Sort, Group, Non-Sort + Hole Punch, Sort + Hole Punch, Sort + Corner Staple, Sort + Corner Staple + Hole Punch, *Sort + 2-Point Staple, *Sort + 2-Point Staple + Hole Punch, Group + Hole Punch, Group + Corner Staple, Group + Corner Staple + Hole Punch, *Group + 2-Point Staple, *Group + 2-Point Staple + Hole Punch.

The initial setting is “Non-Sort.”

*Only when the Finisher FN-3 is mounted.

Intelligent Sorting

Select whether to turn “ON” or “OFF” the function that automatically switches between Sort and Non-Sort, selecting Non-Sort if only a single original is loaded and Sort if two or more originals are loaded in the Electronic Document Handler.

The initial setting is “ON.”

Crisscross Mode

Select whether to enable (“ON”) or disable (“OFF”) crisscross sorting when the conditions for crisscross sorting are met and Sort or Group is selected.

The initial setting is “ON.”

3/6

Realign Warning

Select whether to give (“ON”) a warning message or not (“OFF”) when the original is placed out-of-alignment on the Glass.

The initial setting is “OFF.”

“Small” Originals

Select whether to enable (“ON”) a copy cycle or not (“OFF”) when it is initiated by pressing the Start key with no originals placed on the Original Glass or with an original smaller than the detectable size placed on the Glass in the Auto Paper mode.

If this function is turned “ON,” the copy cycle is run using the paper loaded in the default paper source. If turned “OFF,” a warning message appears to instruct the user to select the paper.

The initial setting is “ON.”

4in1 Copy Order

Select the default copying order in the 4-in-1 mode from among the following two:

1	2
3	4

1	3
2	4

The initial setting is

1	2
3	4

Date Printing Format

Select the format for date printing, i.e., “punctuation,” “date format,” and “year.”

- “Punctuation” can be either XX/XX/XX or XX.XX.XX.

The initial setting is XX/XX/XX.



- “Date Format” can be either '98/12/27, 12/27/'98, DEC/27/'98, 27/12/'98, or 27/DEC/'98.

The initial setting is '98/12/27.

- “Year” can be either 'yy or yyyy.



The initial setting is 'yy.

Date Printing Position

Enter the position at which to print the date by X and Y using the  or  keys. The dimension can range from 3/16” ~1-9/16”.

The initial setting is X: 1/4”, Y: 3/4”.

Page Number Position

Enter the position at which to print the page number using the  or  keys. It can range from 3/16” ~1-9/16” from the bottom of the page.

The initial setting is 1/4”.

4/6

Confirmation Beep

Select whether to turn “ON” or “OFF” the beep that sounds each time a key on the Touch Panel is touched.

The initial setting is “ON.”

5/6

Universal Tray

Select the default paper size detection for the Universal Tray, either Auto Detect or Custom Size.

The initial setting is “Auto Detect.”

Special Paper

Designate a drawer for special paper.

The initial setting is “Normal” for all drawers. See p. 3-10 for Special Paper Setting.

Auto Panel Reset

Select the time it takes the auto panel reset function to be activated from among “30 seconds,” “1 min.,” “2 min.,” “3 min.,” or “5 min.,” or not activate the function at all (“No Reset”).

The initial setting is “1 min.”

Energy Save Mode

Set the time it takes the copier to enter the Energy Saver mode, from 1 min. ~ 240 min. (in 1 min. increments).

The initial setting is “15 min.”

Plug-In Counter Reset

Select whether to reset the panel (“ON”) or not (“OFF”) when the Plug-In Counter is pulled out of the copier or a magnetic card is pulled out of the Data Controller.

The initial setting is “ON.”

Auto Shut Off

Select the time it takes the Auto Shut Off function to be activated, from 15 min. ~ 240 min. in 1 min. increments. Auto Shut Off shuts down the copier a given period of time after the last operation.

The initial setting is 90 min.

* A setting is also possible to disable Auto Shut Off.

Date/Time Set

Set the date and time-of-day.

The initial setting is "1997/04/01, 00:00:00."

Print Exposure

Select the print exposure level from among "Lighter," "Normal," or "Darker."

The initial setting is "Normal."

Priority Device

Select the configuration either as a "Copier" or "Printer."

The initial setting is "Copier."

Density (ADF)

Select the density level according to the original, either Mode 1 or Mode 2.

The initial setting is "Mode 1."

Mode 1: Used for the standard original, such as a word-processor made document.

Mode 2: Effective in reproducing a pale original, such as a faint pencil-written document.

Priority Offset Tray

<Only when the Finisher FN-3 is mounted>

Select the output tray into which copied paper is to be fed, either "Top Tray" or "Bottom Tray."

The initial setting is "Top Tray."

Administrator Mode

This mode is used only by the administrator of your copier. When Administrator Mode is selected, the copier prompts you to enter your "Administrator's #." The following functions can be set only when the correct administrator number is entered.

- Copy Track
- Max. Copy Sets
- Non-Auto Shut Off

The administrator number is set by the Technical Representative. For more details, consult your Technical Representative.

See p. 4-22 for setting the Copy Track function.

<Copy Track>

This function allows the administrator to keep track of the number of copies made in the Copier mode and the number of prints made in the Printer mode for each account.

Select whether to turn "ON" or "OFF" the Copy Track function for "Copier" or "Printer" and select the Copy Track Method, either "100 Accounts" or "1000 Accounts."

The initial setting is "OFF."

When "100 Accounts" is selected:

- ◆ Access Code:
You can program or change your access code (for a max. of 100 accounts).
- ◆ Copy Limit:
You can limit the maximum number of copies that can be made.
- ◆ Total Count:
Displays the count of the Total Counter. You can also clear the counter.
- ◆ Size Count:
Displays the count of the Size Counter. You can also clear the counter.
- ◆ Account No.:
Program or change the account number.

When "1000 Accounts" is selected:

- ◆ Total Count:
Displays the count of the Total Counter. You can also clear the counter.

5. User's Choice

6/6

<Max. Copy Sets>

Limit the number of copies or copy sets that can be made per job.

The initial setting is "OFF."

<Non-Auto Shut Off>

This function can disable the Auto Shut Off function.

Select whether to enable ("ON") or disable ("OFF") the Non-Auto Shut Off function.

The initial setting is "OFF" (disable).

Making the User's Choice Settings

- 1 Press the Utility key.

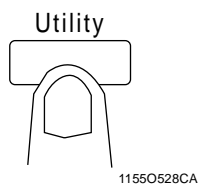

- 2 Touch **User's Choice**.

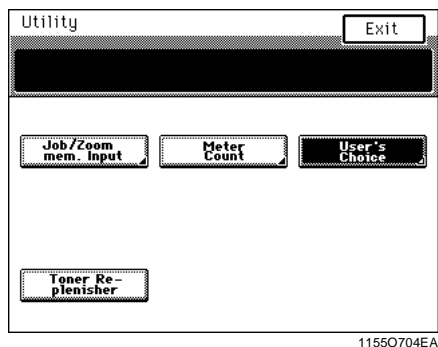

- 3 Select the key of the page number on which the desired User's Choice function is listed. For example, to change Output Priority from Non-Sort to Sort, touch **2/6**.

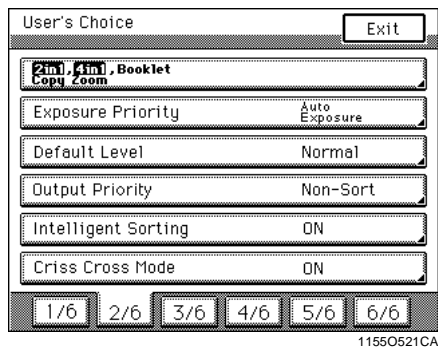

- 4 Touch the key of the desired User's Choice function. For example, touch **Output Priority**.

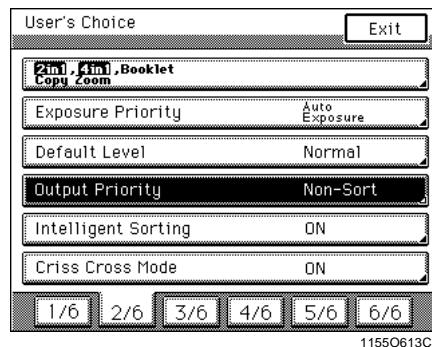

- 5 Touch **Sort**.

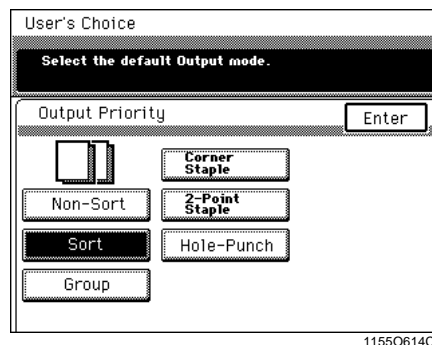

- 6 Touch **Enter**.
*Repeat steps 3 to 6 to make new settings for other User's Choice functions.
- 7 Touch **Exit**.

Copy Track Function

The administrator of the copier should make the setting, either "100 Accounts" or "1000 Accounts."

*If the copier is equipped with a Hard Disk Drive Kit and "100 Accounts" is selected, it is possible to make the User's Choice settings for each account.

Setting the Copy Track Function

1 Press the Utility key.

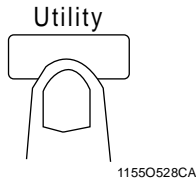

2 Touch **User's Choice**.

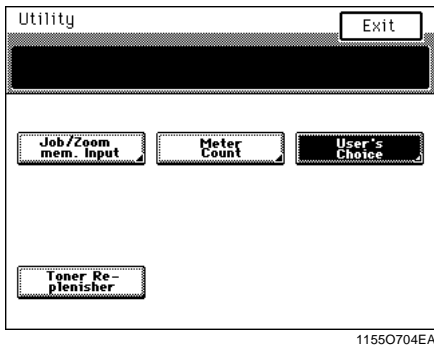

3 Touch **6/6**.

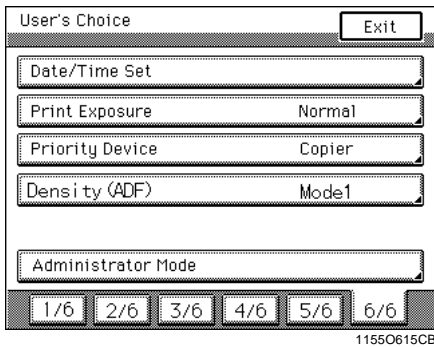

4 Touch **Administrator Mode**.

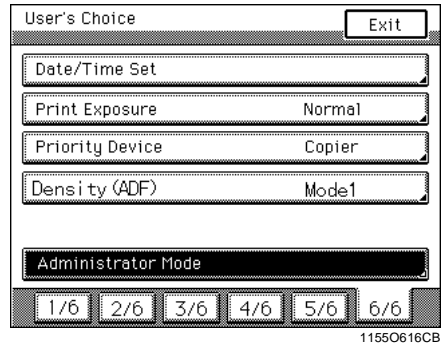

5 Enter the administrator number from the 10-Key Pad.

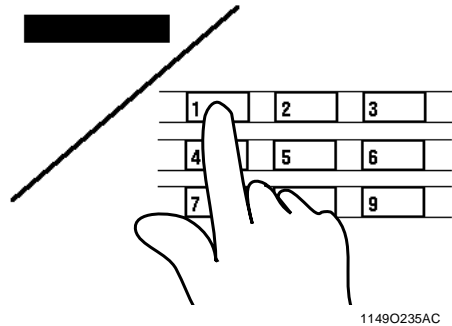

NOTES

- Your Technical Representative is to program and change the administrator number. For details, consult your Technical Representative.
- The administrator should remember the administrator number.

6 Touch **Copy Track** .

User's Choice Exit

Administrator Mode

Copy Track

Copy Track Data

Max. Copy Sets

Non-Auto Shut Off Disable

11550705EA

- 7 Touch **ON** or **OFF** of the desired configuration (Copier or Printer), then select the appropriate Copy Track Method. For example, to keep track of 100 accounts, touch **100 Accounts** , and then **Enter** .

User's Choice

Select the Copy Track mode : ON or OFF, and 100 accounts or 1,000 accounts.

Copy Track Enter

Copy Track

Copier Printer Copy Track method

ON **ON** 100 Accounts

OFF **OFF** 1000 Accounts

11550618CB

- 8 Initialize the Copy Track function data. Touch **Yes** and **Enter** .

User's Choice

Press YES to reset (delete) all the Copy Track data, then press ENTER.

Copy Track Enter

Yes **No**

11550619CA

NOTE

If you change the Copy Track Method, be sure to initialize the Copy Track data.

- 9 Touch **Enter** .

- 10 Touch **Exit** .

User's Choice Exit

Administrator Mode

Copy Track

Copy Track Data

Max. Copy Sets

Non-Auto Shut Off Disable

11550706EA

NOTE

When "100 Accounts" is set, program the access code for each account. Programming the Access Code [p. 4-24](#)

Useful Tip

You can have the copy track data printed on paper.

- Touch **Copy Track Data** .

User's Choice Exit

Administrator Mode

Copy Track

Copy Track Data

Max. Copy Sets

Non-Auto Shut Off Disable

11550707EA

- Place LetterL copy paper on the Intelligent Multi Bypass Tray lengthwise and press the Start key.

Programming the Access Code

An access code can be programmed when "100 Accounts" is selected. These procedures assume that the copier is equipped with a Hard Disk Drive Kit.

1 Press the Utility key.

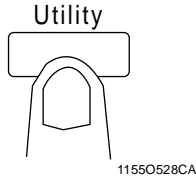

2 Touch **User's Choice**.

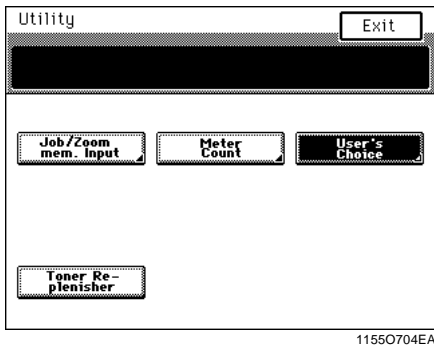

3 Enter the administrator number from the 10-Key Pad.

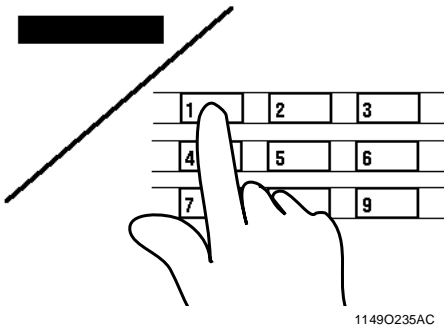

4 Touch **6/6**.

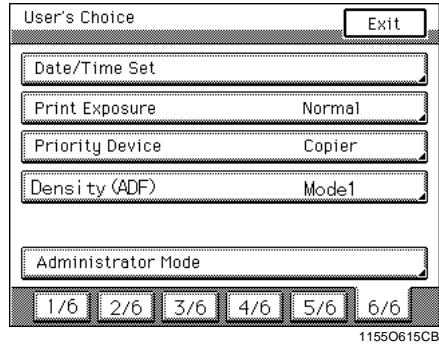

5 Touch **Administrator Mode**.

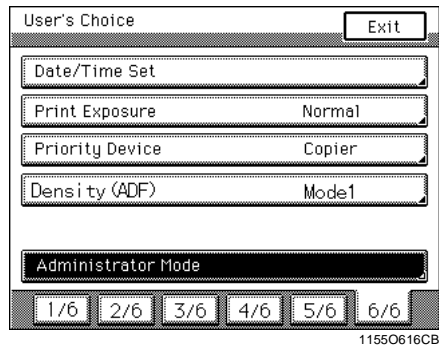

6 Touch **Copy Track Data**.

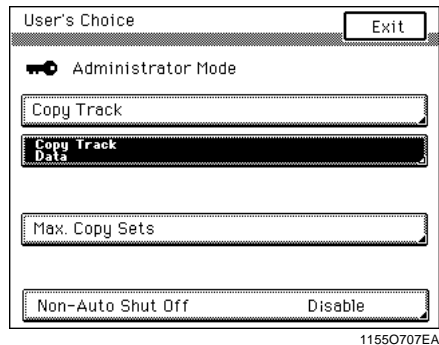

NOTES

- Your Technical Representative is to program and change the administrator number. For details, consult your Technical Representative.
- The administrator should remember the administrator number.

- 7 Select the page number on which the target account is shown.

User's Choice

Copy Track Data can be printed.
Place Letter paper in the Bypass Tray and press the start key.

Copy Track Data

1/20	3/20	5/20	7/20	9/20
11/20	13/20	15/20	17/20	19/20

11550623EA

- 8 Touch the Access Code key of the target account.

User's Choice

Select an account, then input/change the data using the 10-key Pad.

Copy Track Data 1/20

NO.	Total Count	Size Count	Copy Limit	Access Code
0001	0	0	-----	----
0002	0	0	-----	----
0003	0	0	-----	----
0004	0	0	-----	----
0005	0	0	-----	----

11550624CA

- 9 Enter the access code from the 10-Key Pad. Then, touch .

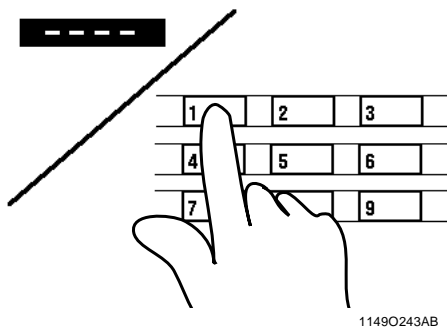

NOTES

- The access code should be a 4-digit number.
- To correct a number entry, press the key and then enter the new number.
- If you want to program an access code for another account, repeat steps 7 through 9.
- If a new access code is programmed, the old one is erased.
- If a new access code entered already exists for another account, the entry is rejected. Enter a different access code.

- 10 Touch .

- 11 Touch .

User's Choice

Administrator Mode

Copy Track

Copy Track Data

Max. Copy Sets

Non-Auto Shut Off

11550706EA

Useful Tip

The account number may be changed by touching the corresponding key and using the 10-Key Pad. If the account number newly entered already exists, that entry is canceled.

Setting a Copy Limit for Each Account

A limit for the number of copies made can be set for each account when "100 Accounts" is selected. These procedures assume that the copier is equipped with a Hard Disk Drive Kit.

1 Press the Utility key.

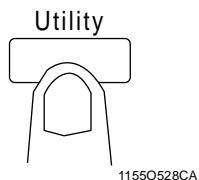

2 Touch **User's Choice**.

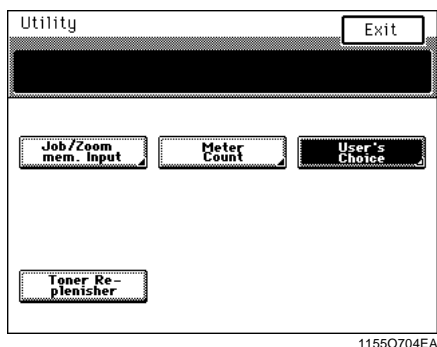

3 Enter the administrator number from the 10-Key Pad.

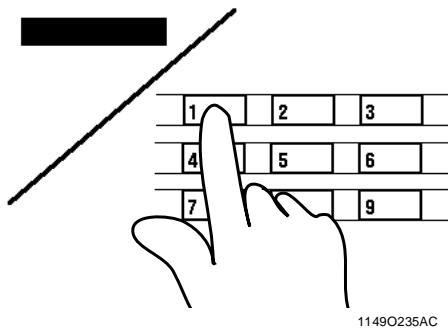

4 Touch **6/6**.

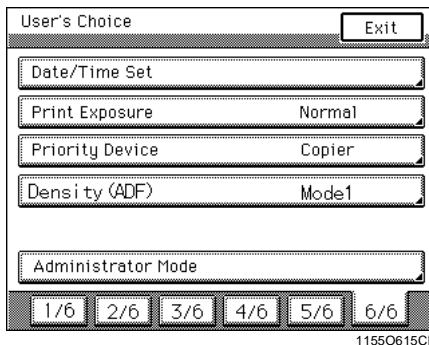

5 Touch **Administrator Mode**.

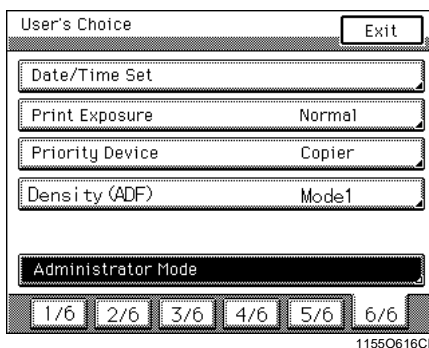

6 Touch **Copy Track Data**.

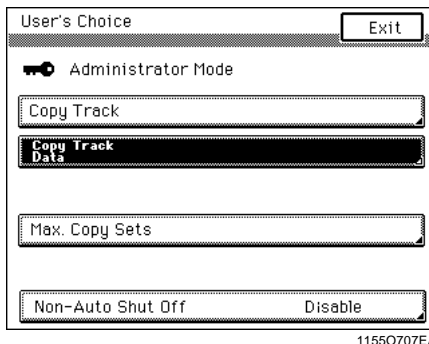

NOTES

- Your Technical Representative is to program and change the administrator number. For details, consult your Technical Representative.
- The administrator should remember the administrator number.

- 7 Select the page number on which the target account is shown.

User's Choice

Copy Track Data can be printed.
Place Letter paper in the Bypass Tray and press the start key.

Copy Track Data

1/20	3/20	5/20	7/20	9/20
11/20	13/20	15/20	17/20	19/20

11550623EA

- 8 Touch the Copy Limit key of the target account.

User's Choice

Select an account, then input/change the data using the 10-key Pad.

Copy Track Data 1/20

NO.	Total Count	Size Count	Copy Limit	Access Code
0001	0	0	-----	1111
0002	0	0	-----	----
0003	0	0	-----	----
0004	0	0	-----	----
0005	0	0	-----	----

11550625CA

- 9 Enter a number for the Copy Limit from the 10-Key Pad. Then, touch .

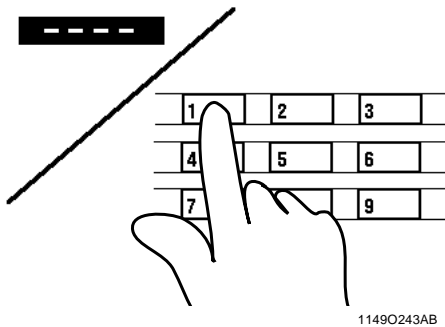

- 10 Touch .

- 11 Touch .

User's Choice

Administrator Mode

Copy Track

Copy Track Data

Max. Copy Sets

Non-Auto Shut Off

11550706EA

NOTES

- To correct a number entry, press the key and then enter the new number.
- If you want to set a Copy Limit for another account, repeat steps 7 through 9.

Clearing Counters for Each Account

A counter can be cleared for each account when "100 Accounts" or "1000 Accounts" is selected. It is also possible to clear all counters of all accounts at once.

1 Press the Utility key.

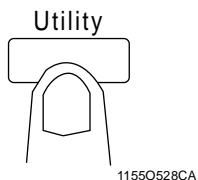

2 Touch **User's Choice**.

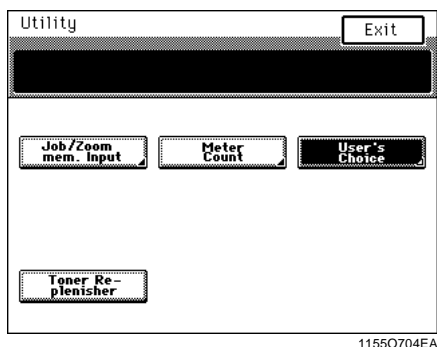

3 Enter the administrator number from the 10-Key Pad.

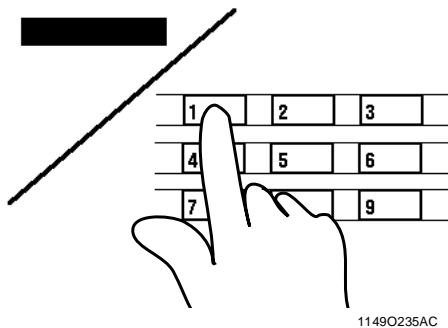

NOTES

- Your Technical Representative is to program and change the administrator number. For details, consult your Technical Representative.
- The administrator should remember the administrator number.
- If "1000 Accounts." is selected, enter the administrator number after step 5.

4 Touch **6/6**.

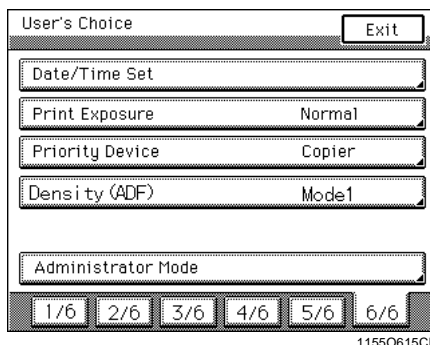

5 Touch **Administrator Mode**.

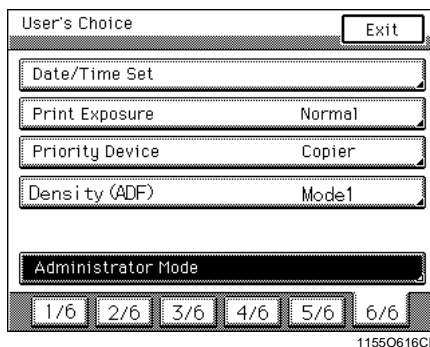

6 Touch **Copy Track Data**.

User's Choice Exit

Administrator Mode

Copy Track

Copy Track Data

Max. Copy Sets

Non-Auto Shut Off Disable

11550707EA

7 Select the page number on which the target account is shown.

User's Choice

Copy Track Data can be printed.
Place Letter paper in the Bypass Tray and press the start key.

Copy Track Data Enter

All Counter Reset

1/20	3/20	5/20	7/20	9/20
11/20	13/20	15/20	17/20	19/20

11550623EA

Useful Tip

To clear the counters of all accounts at once, touch **All Counter Reset**.

8 Touch the counter key of the target account.

User's Choice Enter

Select an account, then input/change the data using the 10-key Pad.

Copy Track Data 1/20 Next

NO.	Total Count	Size Count	Copy Limit	Access Code
0001	500	100	1000	1111
0002	300	50	1000	2222
0003	400	60	1000	3333
0004	500	70	1000	4444
0005	600	80	1000	5555

11550626CA

9 Press the **C** key and then touch **Enter**.

User's Choice Enter

Select an account, then input/change the data using the 10-key Pad.

Copy Track Data 1/20 Next

NO.	Total Count	Size Count	Copy Limit	Access Code
0001	0	100	1000	1111
0002	300	50	1000	2222
0003	400	60	1000	3333
0004	500	70	1000	4444
0005	600	80	1000	5555

11550627CB

NOTE

If you want to clear the counter of another account, repeat steps 7 through 9.

Useful Tip

To undo a clear operation, press the Interrupt key.

10 Touch **Enter**.11 Touch **Exit**.

User's Choice Exit

Administrator Mode

Copy Track

Copy Track Data

Max. Copy Sets

Non-Auto Shut Off Disable

11550706EA

Chapter 5

When a Message Appears

1. When the Message “The current Paper Drawer is empty.” Appears

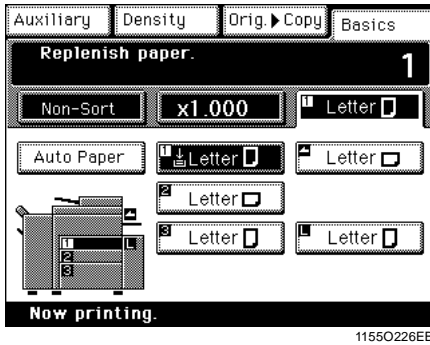

When the drawer currently selected for use runs out of paper, the message shown on the left appears. The current copy cycle is interrupted and you cannot start a new copy cycle. The blinking drawer has run out of paper.

Add paper by using the following procedure.

Adding paper

1st Drawer

1 Slide out the 1st Drawer.

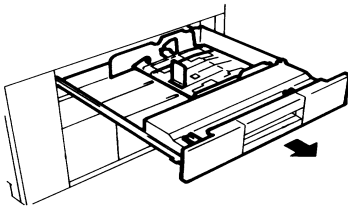

1075O101DA

3 Slide the Drawer back in.

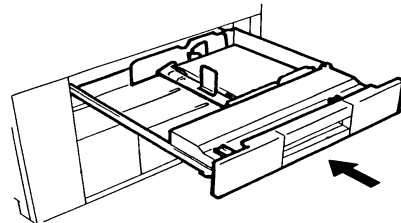

1161O095DA

2 Load the paper stack into the Drawer so that its front side faces down.

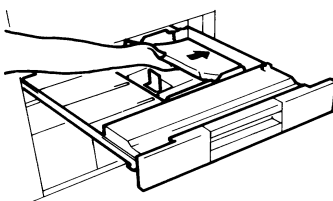

1161O009AA

NOTE

The paper should be loaded no higher than the ▼ (Max. Level Indicator).

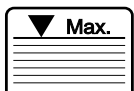

1145O555KA

1. When the Message “The current Paper Drawer is empty.” Appears

2nd Drawer

1 Slide out the 2nd Drawer.

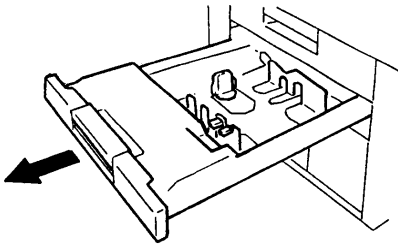

1161O096DA

4 Slide the Drawer back in.

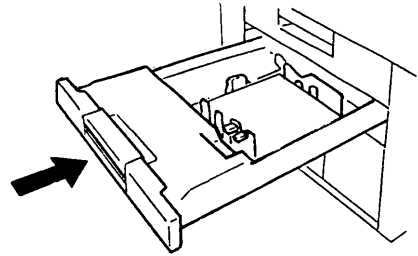

1161O104DA

2 Slide the Edge Guides in the direction of the arrow to suit the paper size.

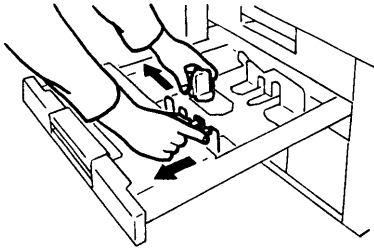

1161O097DA

3 Load the paper stack into the Drawer so that its front side faces down.

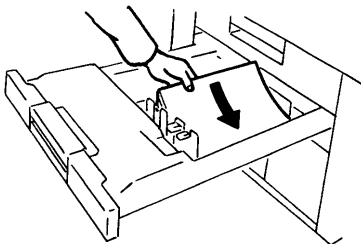

1161O099DA

NOTE

The paper should be loaded no higher than the ▼ (Max. Level Indicator).



1145O555KA

1. When the Message “The current Paper Drawer is empty.” Appears

3rd Drawer

- 1 Press the Paper Descent Key and then slide the Drawer out.

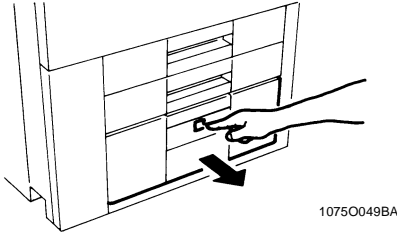

Indication of the Paper Descent Key



Steady Light:
The 3rd Drawer has run out of paper when a Drawer other than the 3rd is currently selected for use.



Blinking Light:
The 3rd Drawer has run out of paper when the 3rd Drawer is currently selected for use.

- 3 Load another paper stack into the left half of the Drawer, front side face down. Press the leading edge of the paper stack tightly up against the left side of the Drawer.

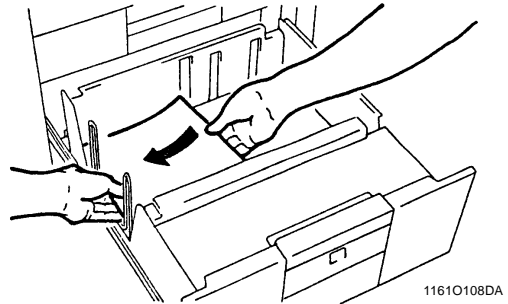

NOTE

The paper should be loaded no higher than the ▼ (Max. Level Indicator).

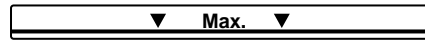

- 2 Load the paper stack into the right half of the Drawer, front side face down. Press the leading edge of the paper stack tightly up against the right side of the Drawer.

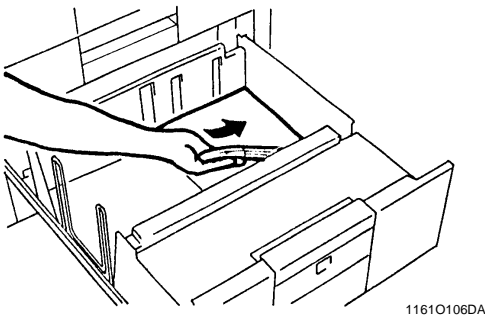

- 4 Slide the Drawer back in and press the Paper Descent Key.

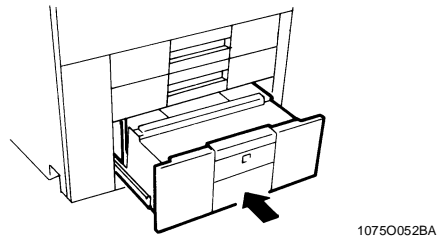

NOTE

The paper should be loaded no higher than the ▼ (Max. Level Indicator).



1. When the Message “The current Paper Drawer is empty.” Appears

Large Capacity Cassette

- 1** Holding the Door Lock Release Lever, open the Cassette Door.

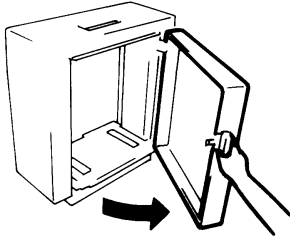

1134O055AA

When adding paper to a partially loaded Cassette, press the Paper Plate Descent Key to lower the Paper Plate before opening the Cassette Door.

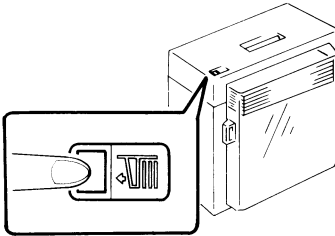

1134O031AA

- 2** Place the paper stack onto the Paper Plate so that its front side faces up.

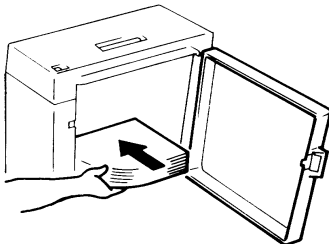

1134O054AA

NOTES

- Make sure that the leading edge of the paper stack is pressed tightly up against the Guide Plate on the take-up side of the Cassette.
- The paper should be loaded no higher than the ▼ (Max. Level Indicator).



1145O055KA

- 3** Close the Cassette Door.

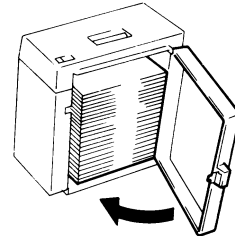

1134O033AA

- * This causes the Paper Plate to rise automatically.

NOTE

The Paper Plate may not ascend if the Cassette Door is not closed completely. Be sure to close the Door completely.

2. When the Message “Replenish Toner.” Appears

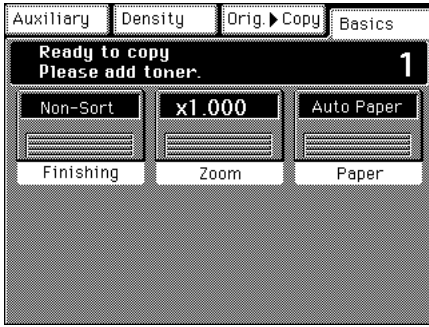

1155O629CB

The message shown on the left appears when toner is soon running out. You can still make copies, but the image density will become lighter and lighter. It is recommended therefore that you replace the Toner Bottle as soon as possible.

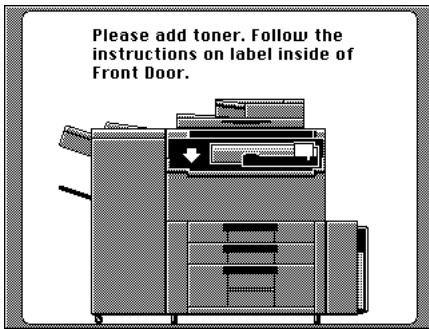

1155O630CA

When toner has run out, the message shown on the left appears and you can no longer start a new copy cycle. Replace the Toner Bottle with a new one by following the procedure given below.

Replacing the Toner Bottle

- 1 Swing down the Upper Front Door.

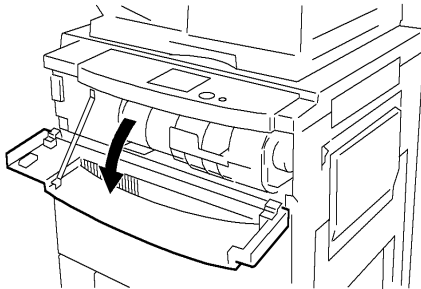

1155O064AA

- 2 Swing open the Toner Bottle Holder and pull out the used Toner Bottle.

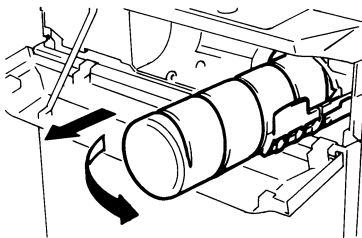

1075O054AA

- 3 Tap a new Toner Bottle against a desk or other hard surface four to five times. Then, turn the Toner Bottle upside down and tap it in the same way again.

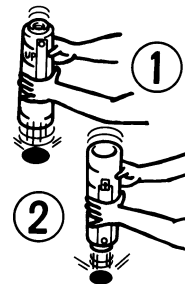

1075O229AA

2. When the Message “Replenish Toner.” Appears

- 4 Shake the new Toner Bottle well and turn it over lengthwise five times.

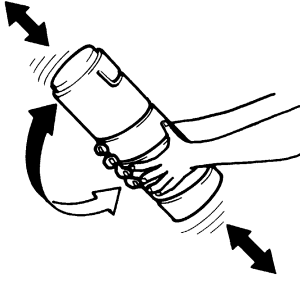

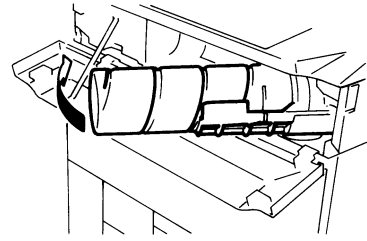

1075O266AA

- 7 Swing the Toner Bottle Holder closed and close the Front Door.



1075O059AA

- 5 With the “UP” marking on top, insert the Bottle into position. Check that the  marking on the Bottle is aligned with the  marking on the Toner Bottle Holder.

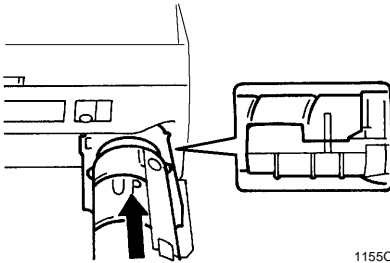

1155O065AA

- 6 Pull the seal off the Toner Bottle.

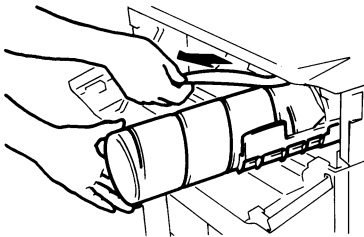

1075O058AA

NOTES

- Use *ONLY* the specified toner for this copier. Using any other toner could result in trouble.
- Do not throw away, but keep, the used Toner Bottle which will be collected by your Tech. Rep.
- Be careful not to drop the Toner Bottle from a 1 m or more height. It may cause damage to the Toner Bottle.
- When the Front Door is closed, the copier automatically starts replenishing the supply of toner. During this period, do not attempt to turn OFF the Power Switch or open the Front Door.

Toner Replenisher

Use the Toner Replenisher function available from the User Mode if the image is light immediately after the Toner Bottle has been replaced with a new one. ☞ p. 4-13

3. When the Message “The Staple Cartridge is empty.” Appears

<Only when the Finisher FN-3 is mounted>

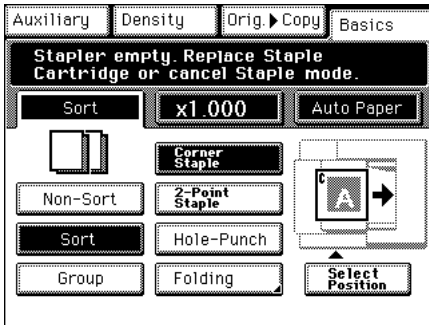

1155P021CA

The message shown on the left appears when the staples are running out.

Replace the Staple Cartridge with a new one by following the procedure given below.

Replacing the Staple Cartridge

<Only when the Finisher FN-3 is mounted>

- 1 Holding the Finisher Lock Release Lever, slide the Finisher away from the copier.

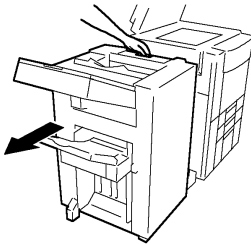

1155O066AA

- 2 Open the Finisher Front Door.

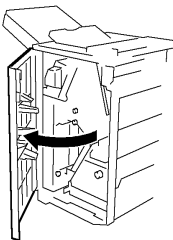

1155O067AA

- 3 Slide out the Staple Unit.

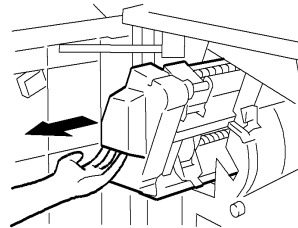

1155O067AA

- 4 While pressing down the Staple Cartridge Lever, pull the Staple Cartridge out its port.

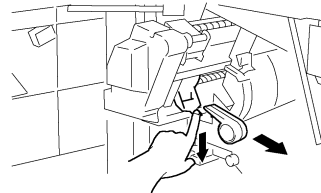

1155O069AA

3. When the Message “The Staple Cartridge is empty.” Appears

- 5** Pull the staple sheet about 3 cm out of the new Staple Cartridge and break off that portion.

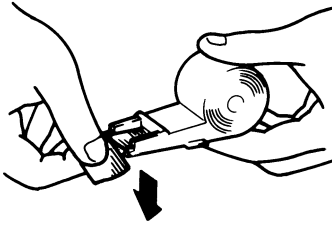

1136O012AA

- 8** Slide the Finisher back against the copier.

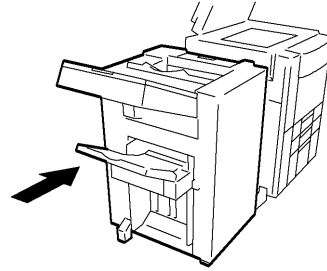

1155O072AA

NOTE

Check that no portion of the staple sheet hangs out of the cartridge. Break off any portion of the sheet that hangs out of the cartridge.

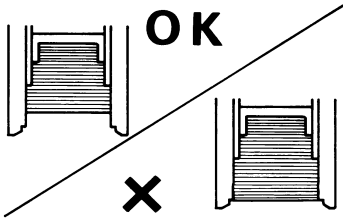

1134O076AA

- 9** Touch **Staple** and the copier automatically feeds a sheet of paper to test the stapling.



1155O633CA

- 6** Insert the new Staple Cartridge until it clicks into position.

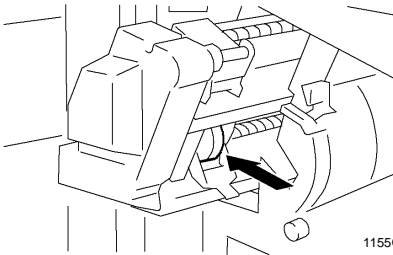

1155O070AA

- 7** Push the Staple Unit back in and close the Finisher Front Door.

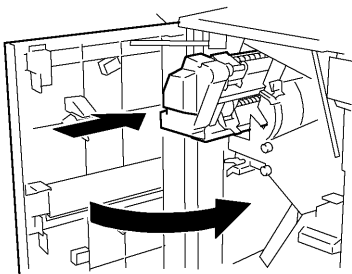

1155O071AA

- 10** Remove the sheet of paper to check that it has been properly stapled.

- * If no staples are evident, repeat the procedure from the beginning.

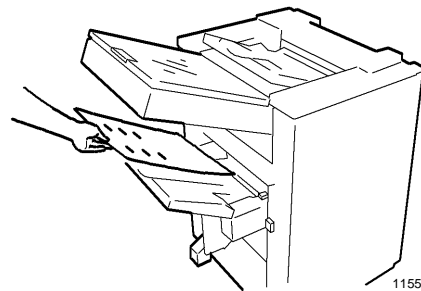

1155O644AC

NOTES

- Replace the Staple Cartridge only after you are prompted to do that by the message. Removing the Staple Cartridge before then will result in stapling trouble.
- After a new Staple Cartridge has been installed, be sure to run a test-stapling sequence to ensure that staples are properly driven into the paper.

4. When the Message “A paper misfeed has been detected.” Appears

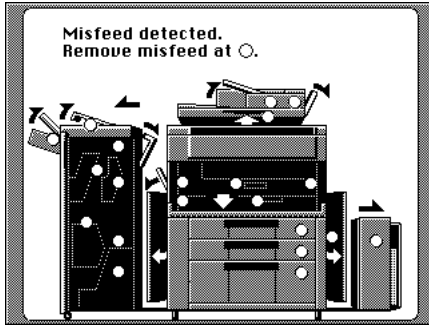

If a paper misfeed occurs during a copy cycle, the message shown on the left appears and that particular copy cycle is stopped in the middle of operation.

Clear the misfed sheet of paper according to the procedure given below.

Misfeed Location Displays

Different procedures are used to clear a misfed sheet of paper depending on the location. First, isolate the location, then clear the misfeed according to the procedure applicable to the misfeed occurring at that particular location. A blinking dot “○” indicates that there is a misfeed at that location. A lit dot “○” indicates that there might be a sheet of paper stopped at that location.

Copier p. 5-12

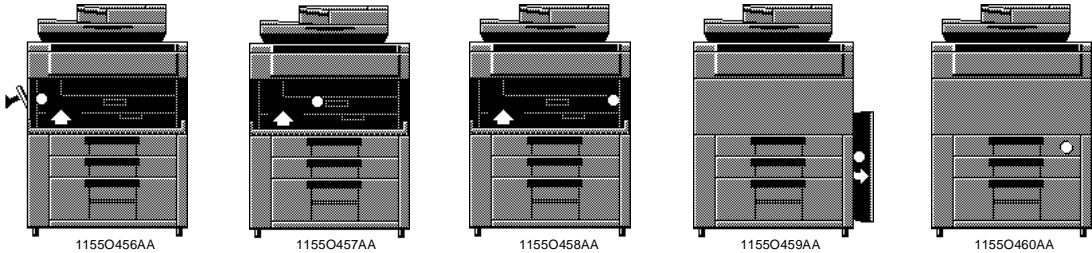

Duplex Unit p. 5-14

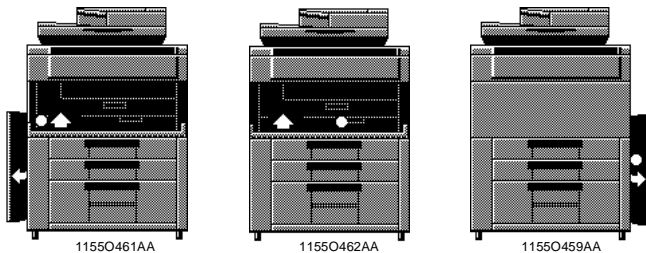

Electronic Document Handler p. 5-16

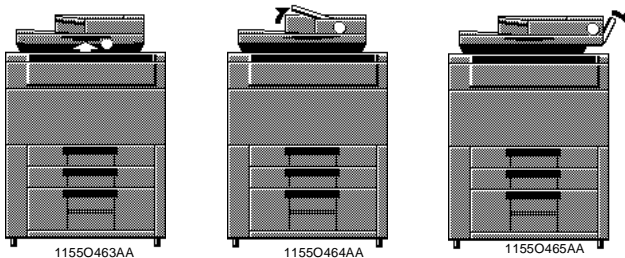

4. When the Message “A paper misfeed has been detected.” Appears

Large Capacity Cassette p. 5-18

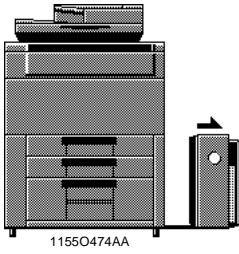

Intelligent Multi Bypass Tray p. 5-19

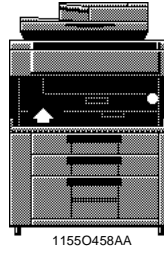

Finisher FN-3 p. 5-20

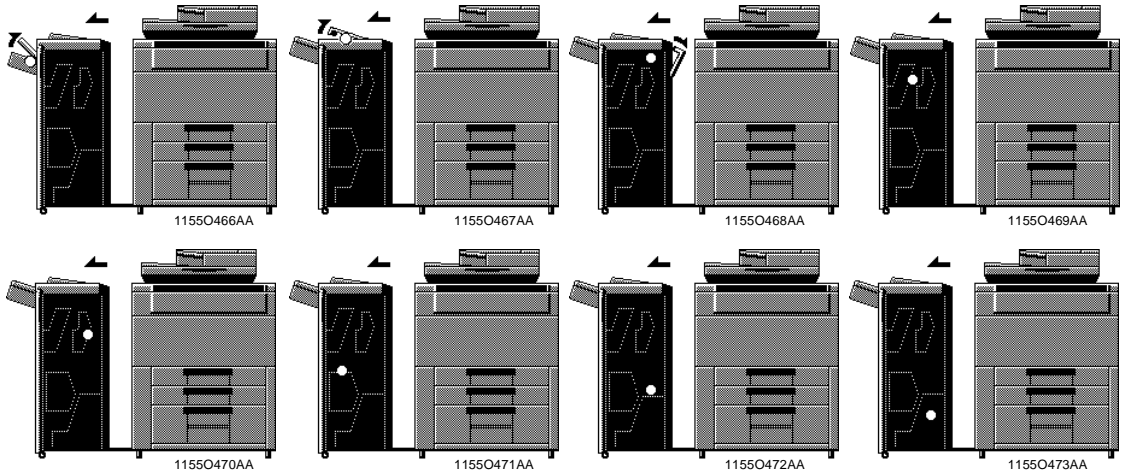

4. When the Message "A paper misfeed has been detected." Appears

Misfeed Clearing Procedures

Copier

- 1 Open the Misfeed Clearing Guide **L1**, pull out the sheet of paper.

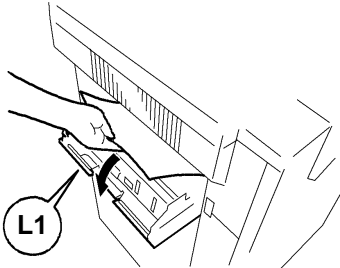

1155O558AB

- 2 Open the Left Door.

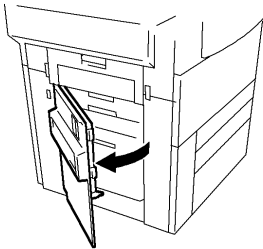

1155O076AA

- 3 Open the Front Door.

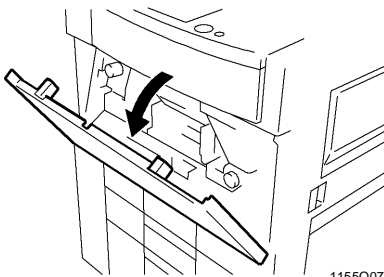

1155O077AA

- 4 Turning Knob **M1**, pull out the sheet of paper. Then turn Knob **D1** to return any paper to the Duplex Unit.

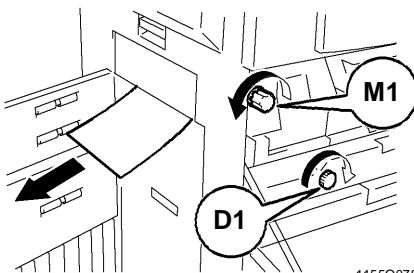

1155O078AA

- 5 Close the Left Door.

- 6 Open the Right Door.

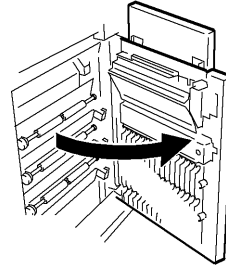

1155O079AA

- 7 Turning Knob **M2**, pull out the sheet of paper.

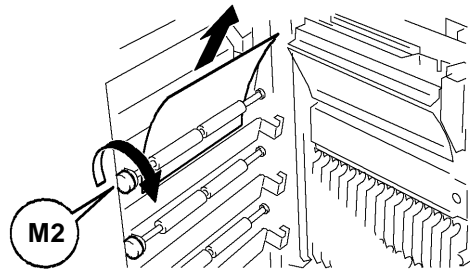

1155O080AA

- 8 Close the Right Door.

- 9 Turn Knob **M3** to feed the sheet of paper.

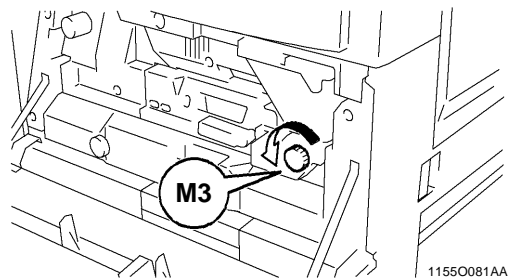

1155O081AA

- 10 Lower the **M4** Lever and slide out the **M5** Unit.

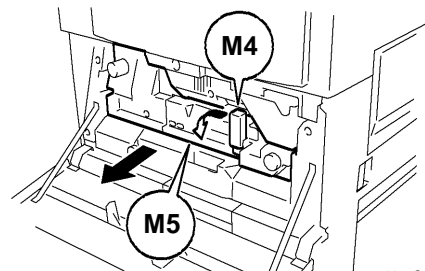

1155O082AA

4. When the Message “A paper misfeed has been detected.” Appears

- 11** Raising Misfeed Clearing Guide **M6** , remove the sheet of paper.

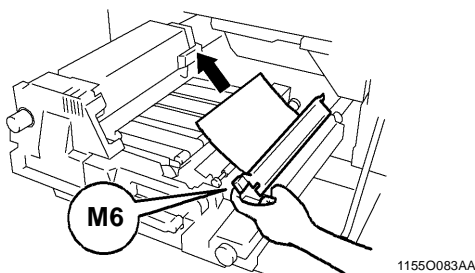

- 12** Turn Knob **M7** and remove the sheet of paper.

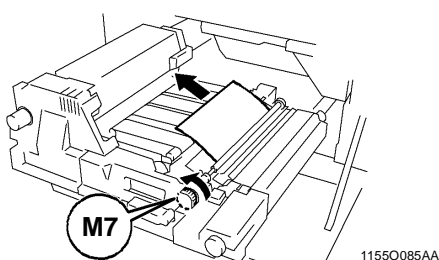

- 13** Opening Misfeed Clearing Guide **M8** , remove the sheet of paper.

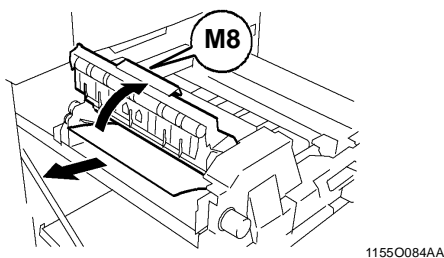

⚠ CAUTION

The area around the Fusing Unit is very hot. Do not touch anything but the paper to prevent you from getting burned.

- 14** Slide in the **M5** Unit and raise the **M4** Lever back up again.

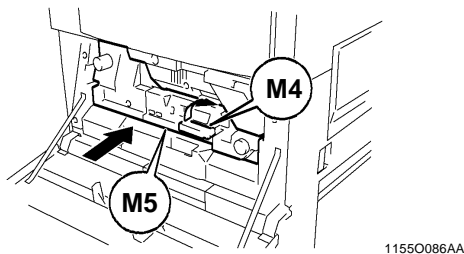

- 15** Close the Front Door.

- 16** Slide out the drawer being used and take out the paper stack left in it.

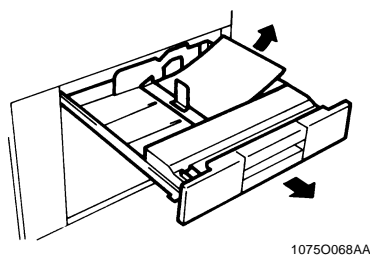

- 17** Reload the paper stack and slide the drawer into the copier.

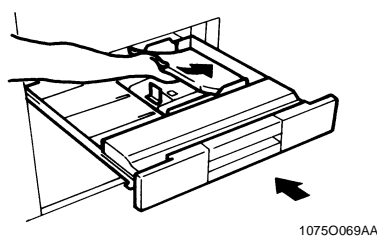

- 18** To reset the paper misfeed indication on the Touch Panel, open and close the Front Door.

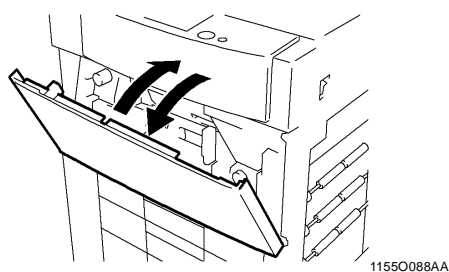

Useful Tip

After the paper misfeed has been cleared, the copier automatically resumes a print cycle without pressing the Start key.

4. When the Message “A paper misfeed has been detected.” Appears

Duplex Unit

1 Open the Left Door.

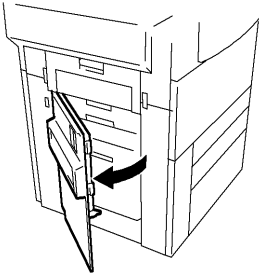

1155O076AA

2 Open the Front Door.

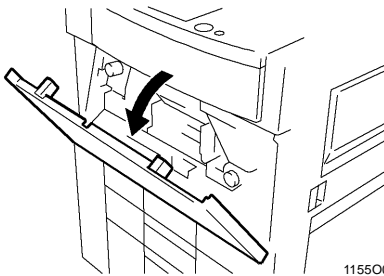

1155O077AA

3 Turning Knob **M1** , pull out the sheet of paper. Then turn Knob **D1** to return any paper to the Duplex Unit.

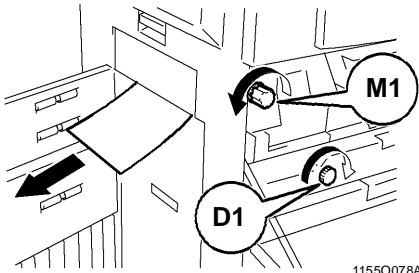

1155O078AA

4 Close the Left Door.

5 Open the Right Door.

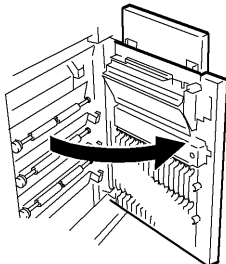

1155O079AA

6 Turning Knob **M2** , pull out the sheet of paper.

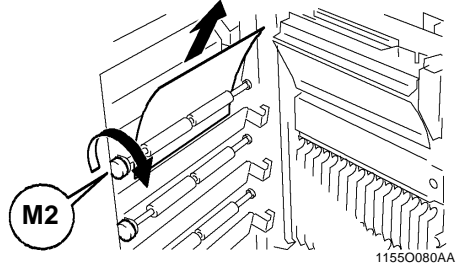

1155O080AA

7 Close the Right Door.

8 Slide out Duplex Unit **D2** .

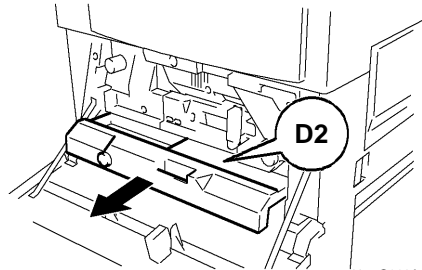

1155O089AA

9 Raising Misfeed Clearing Guide **D3** , remove the sheet of paper.

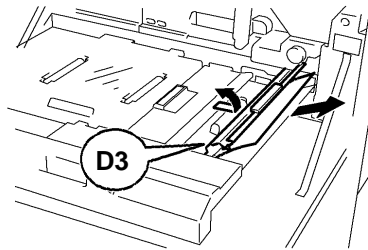

1155O090AA

10 Raising Misfeed Clearing Guide **D4** , remove the sheet of paper.

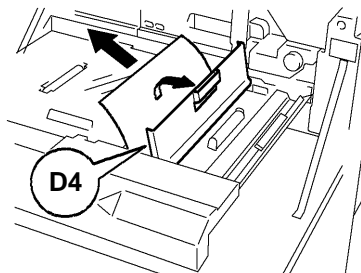

1155O091AA

4. When the Message “A paper misfeed has been detected.” Appears

- 11** Raising Misfeed Clearing Guide **D5** ,
remove the sheet of paper.

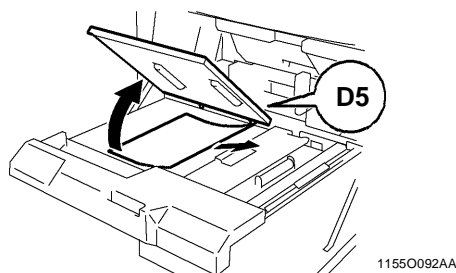

- 12** Slide Duplex Unit **D2** back into the
copier.

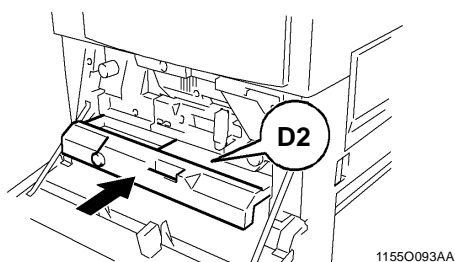

- 13** Close the Front Door.

Useful Tip

After the paper misfeed has been cleared, the copier automatically resumes a print cycle without pressing the Start key.

4. When the Message “A paper misfeed has been detected.” Appears

Electronic Document Handler

- 1** Unload the originals from the Document Handling Tray.

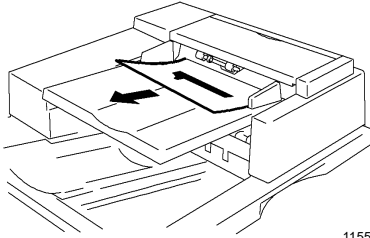

1155O094AA

- 2** Open Misfeed Clearing Guide **F1**.

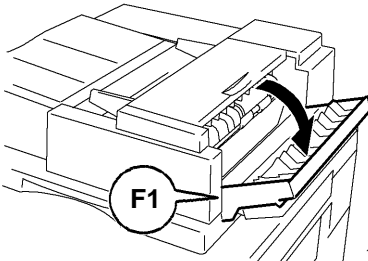

1155O095AA

- 3** Open Misfeed Clearing Guide **F2** and gently pull out the original.

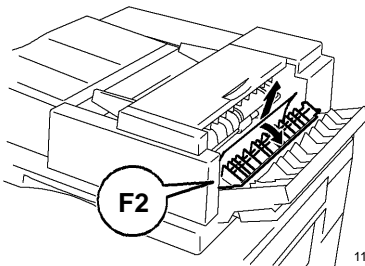

1155O096AA

- 4** Pull up the Document Handling Tray until a click is heard and then gently pull out the original.

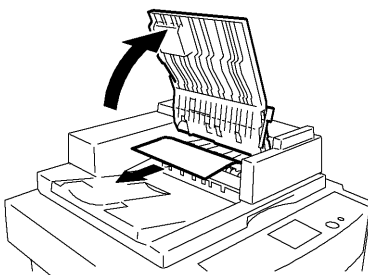

1155O097AA

- 5** Pulling up Misfeed Clearing Tray **F4**, gently pull out the original.

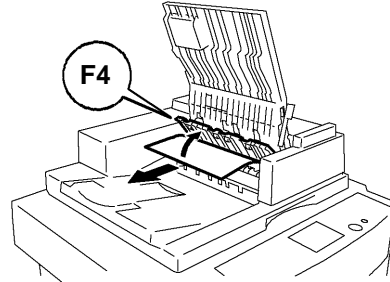

1155O098AA

- 6** Pinching the lever on the Document Tray, bring the tray back down.

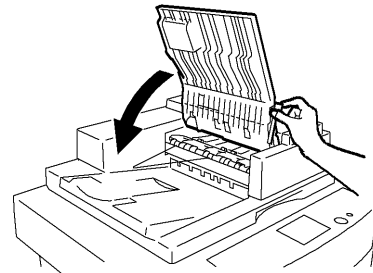

1155O404AA

- 7** Raise the Electronic Document Handler.

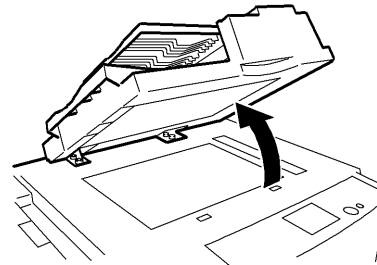

1155O099AA

- 8** Opening the **F5** Lever, gently pull out the original.

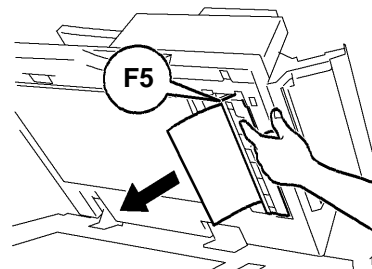

1155O527AA

4. When the Message “A paper misfeed has been detected.” Appears

- 9** Opening the **F6** Lever, gently pull out the original.

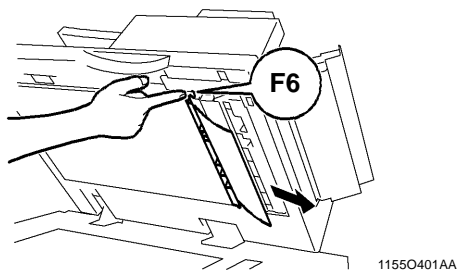

1155O401AA

- 10** Lower the Electronic Document Handler.

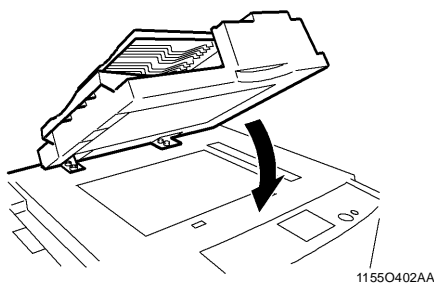

1155O402AA

- 11** Close Misfeed Clearing Guides **F1** and **F2**.

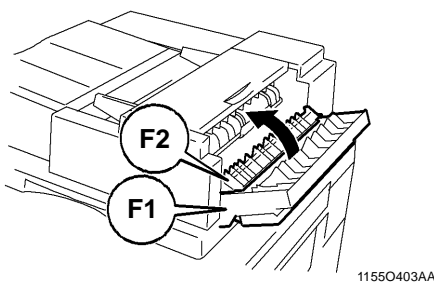

1155O403AA

- 12** Reload the originals as instructed on the Touch Panel.

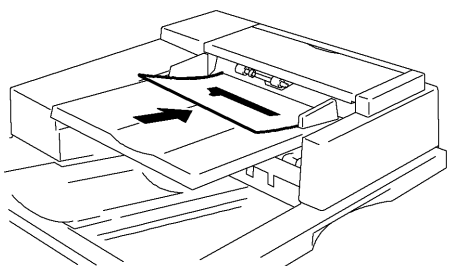

1155O405AA

4. When the Message “A paper misfeed has been detected.” Appears

Large Capacity Cassette

- 1** Press the Paper Descent Key.

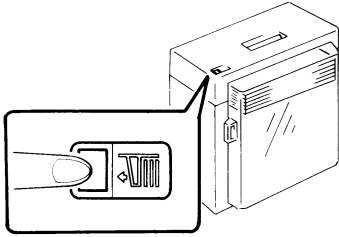

1134O031AA

- 5** Remove the sheet of paper.

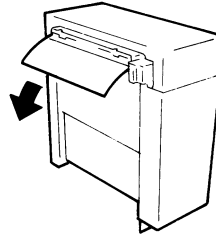

1134O029AA

- 2** Holding the Door Lock Release Lever, open the Cassette Door and remove the sheet of paper.

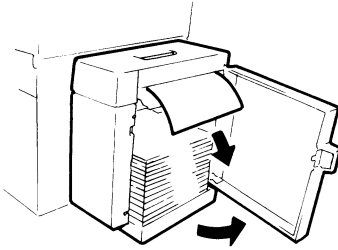

1134O027AA

- 6** Slide the Cassette back against the copier.

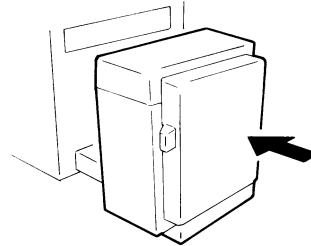

1134O030AA

- 3** Close the Cassette Door.

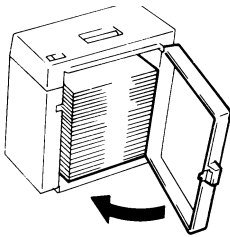

1134O033AA

- 4** Press the Lock Release Lever and slide the Cassette away from the copier.

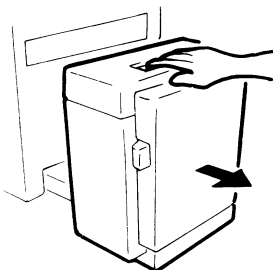

1134O028AA

4. When the Message “A paper misfeed has been detected.” Appears

Intelligent Multi Bypass Tray

- 1 Unload the paper stack from the Intelligent Multi Bypass Tray and open the Right Door.

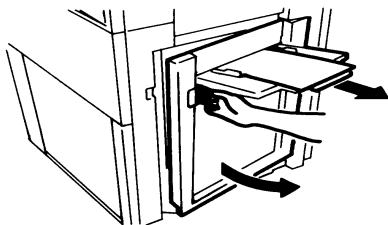

1075O071AB

- 2 Pull out the sheet of paper from the Paper Take-Up Section. Then, close the Right Door.

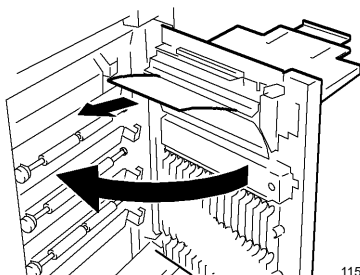

1155O087AA

- 3 Place the paper stack back on the tray.

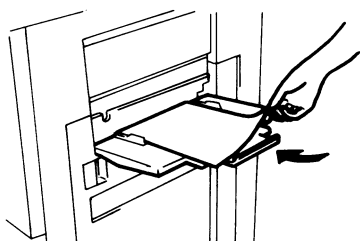

1075O073AA

- 4 To reset the paper misfeed indication on the Touch Panel, open and close the Front Door.

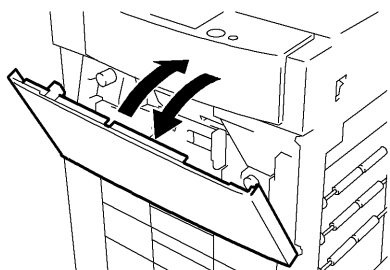

1155O088AA

4. When the Message “A paper misfeed has been detected.” Appears

Finisher FN-3

<When the following dots are lit:>

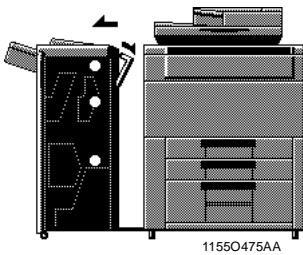

- 1** Holding the Finisher Lock Release Lever, slide the Finisher away from the copier.

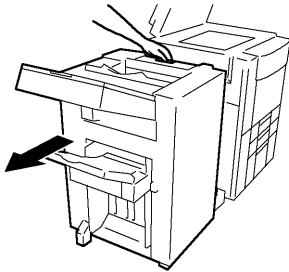

1155O066AA

- 2** Opening Misfeed Clearing Guide **FN1**, remove the sheet of paper.

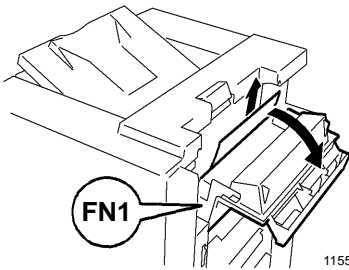

1155O406AA

- 3** Loosen two screws, open the Misfeed Clearing Guide and remove the sheet of paper.

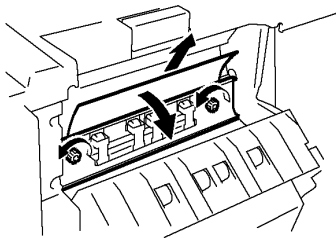

1155O700AA

- 4** Close the Misfeed Clearing Guide and tighten the screws.

- 5** Open the Finisher Front Door.

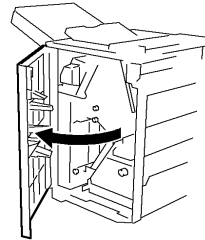

1155O067AA

- 6** Raising Misfeed Clearing Guide **FN3**, remove the sheet of paper.

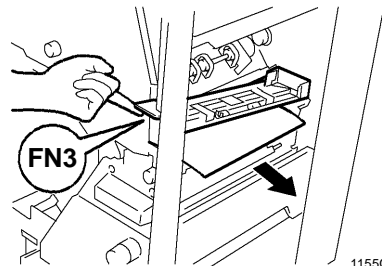

1155O407AA

- 7** Turn Knob **FN2** to feed the sheet of paper.

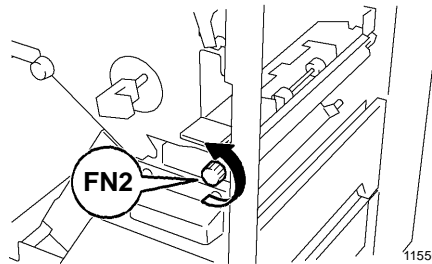

1155O408AA

- 8** Open Misfeed Clearing Guide **FN4**.

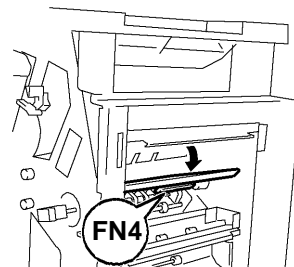

1155O409AA

4. When the Message “A paper misfeed has been detected.” Appears

- 9** Remove the sheet of paper and close Misfeed Clearing Guide **FN4**.

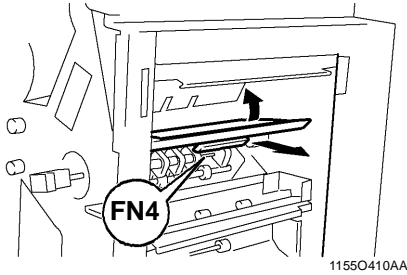

1155O410AA

- 10** Turn Knobs **FN7** and **FN6** to feed the sheet of paper.

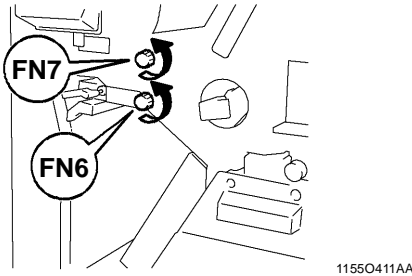

1155O411AA

- 11** Pinching the lever of Misfeed Clearing Guide **FN5**, open **FN5**.

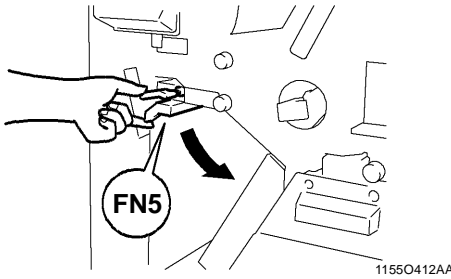

1155O412AA

- 12** Remove the sheet of paper and close **FN5**.

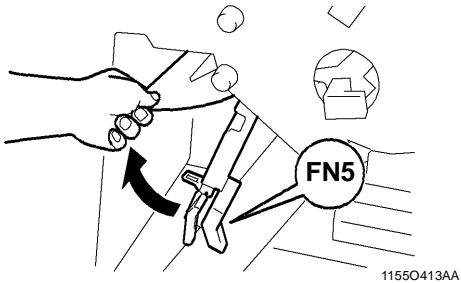

1155O413AA

- 13** Close the Finisher Front Door.

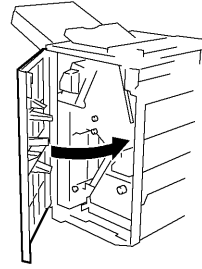

1155O645AA

- 14** Slide the Finisher back against the copier.

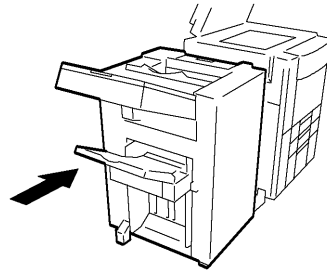

1155O072AA

4. When the Message “A paper misfeed has been detected.” Appears

<When the following dots are lit:>

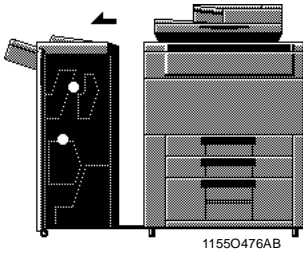

- 1** Holding the Finisher Lock Release Lever, slide the Finisher away from the copier.

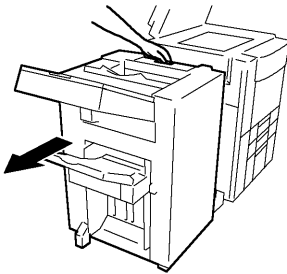

- 2** Open the Finisher Front Door.

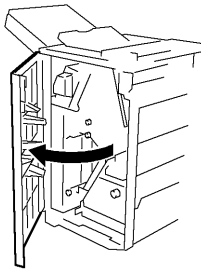

- 3** Pinching the lever of Misfeed Clearing Guide **FN8**, open **FN8**.

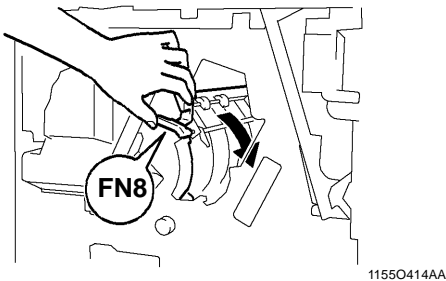

- 4** Remove the sheet of paper and close **FN8**.

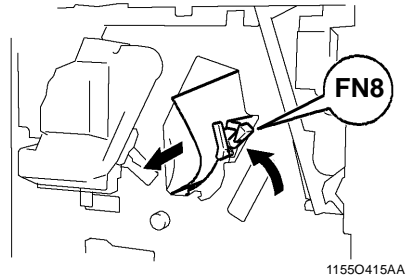

- 5** Turn Knobs **FN7** and **FN6** to feed the sheet of paper.

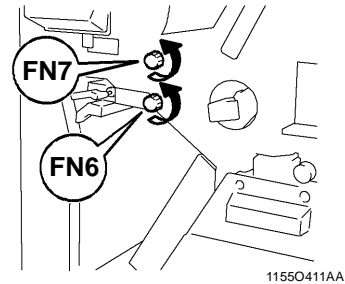

- 6** Pinching the lever of Misfeed Clearing Guide **FN5**, open **FN5**.

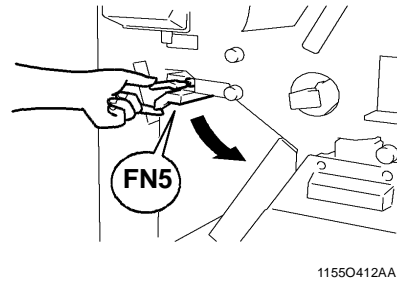

- 7** Remove the sheet of paper and close **FN5**.

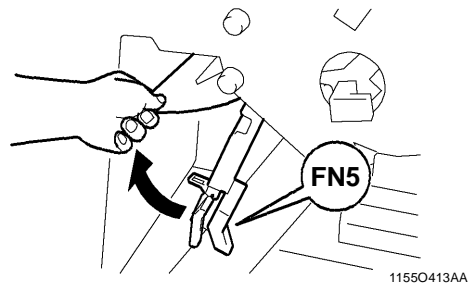

4. When the Message “A paper misfeed has been detected.” Appears

- 8** Close the Finisher Front Door.

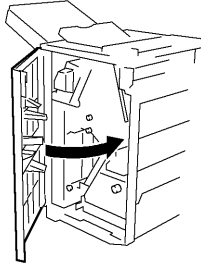

1155O645AA

- 9** Slide the Finisher back against the copier.

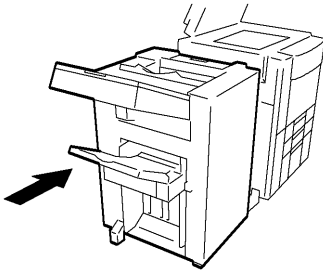

1155O072AA

<When the following dots are lit:>

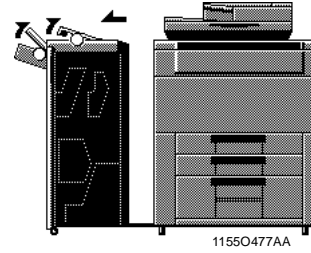

1155O477AA

- 1** Open Exit Tray **FN9** and remove the sheet of paper.

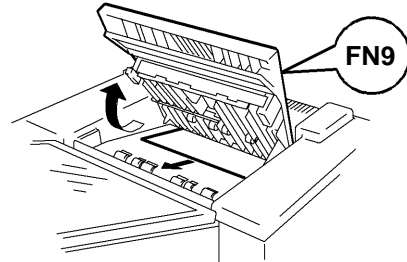

1155O424AA

- 2** Close **FN9**.

- 3** Open Manual Staple Tray Cover **FN10** and remove the sheet of paper.

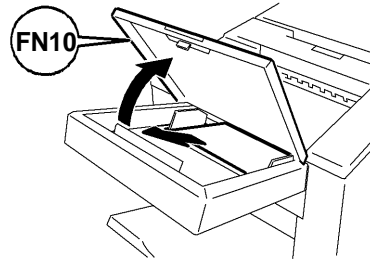

1155O425AA

- 4** Close **FN10**.

4. When the Message “A paper misfeed has been detected.” Appears

<When the following dots are lit:>

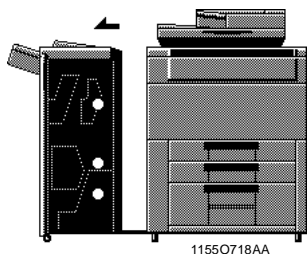

1155O718AA

- 1** Holding the Finisher Lock Release Lever, slide the Finisher away from the copier.

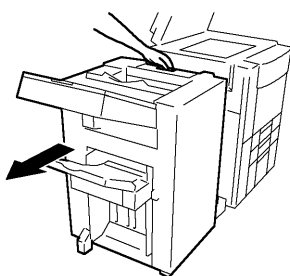

1155O066AA

- 2** Open the Finisher Front Door.

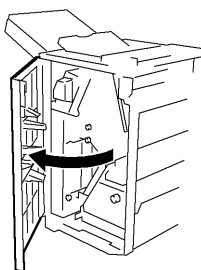

1155O067AA

- 3** Raising Misfeed Clearing Guide **FN3**, remove the sheet of paper.

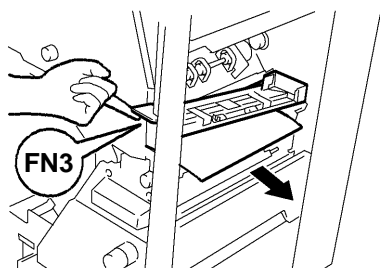

1155O407AA

- 4** Turn Knob **FN2** to feed the sheet of paper.

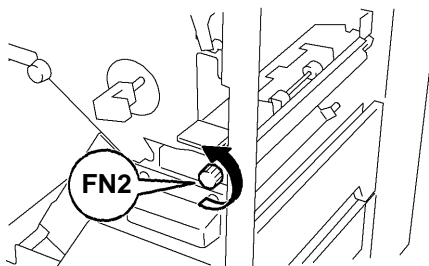

1155O408AA

- 5** Open Misfeed Clearing Guide **FN4**.

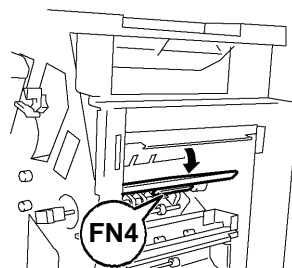

1155O409AA

- 6** Remove the sheet of paper and close Misfeed Clearing Guide **FN4**.

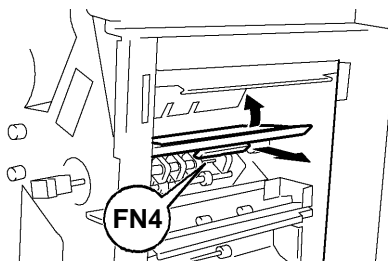

1155O410AA

- 7** Turn Knobs **FN7** and **FN6** to feed the sheet of paper.

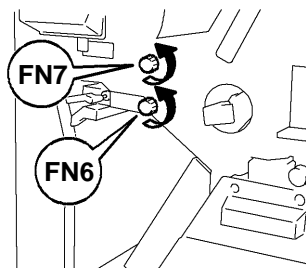

1155O411AA

4. When the Message “A paper misfeed has been detected.” Appears

- 8** Pinching the lever of Misfeed Clearing Guide **FN5**, open **FN5**.

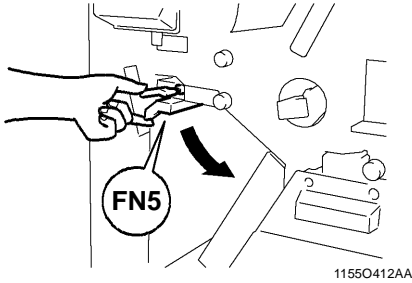

- 9** Remove the sheet of paper and close **FN5**.

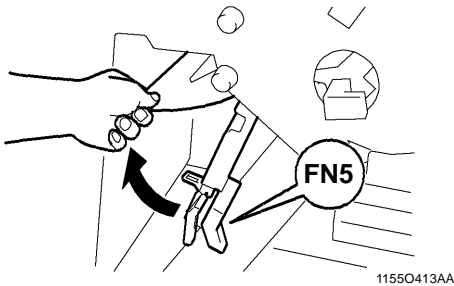

- 10** Turn Knobs **FN2** and **PF1** together five turns to feed the sheet of paper.

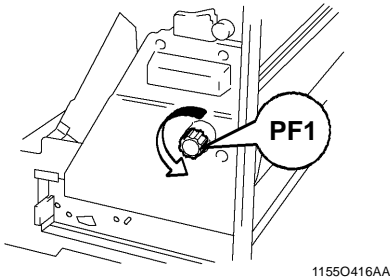
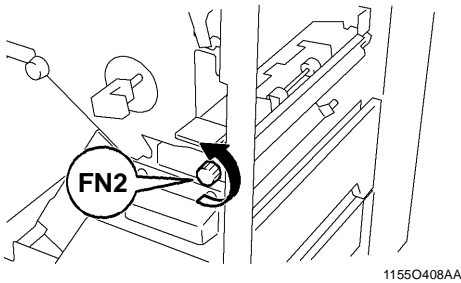

- 11** Check to see if a sheet of paper is left in the Finisher. If any is visible, perform step 10 once again.

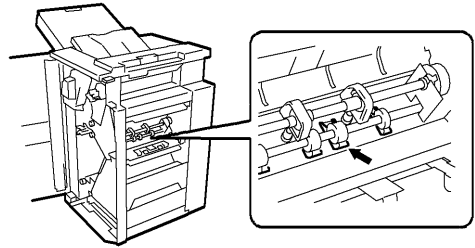

NOTE

Sliding out Paper Folding Unit **PF2** with a sheet of paper left inside could result in a malfunction.

- 12** Open Misfeed Clearing Guide **FN4**.

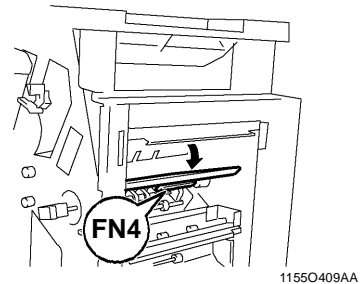

- 13** Remove the sheet of paper and close Misfeed Clearing Guide **FN4**.

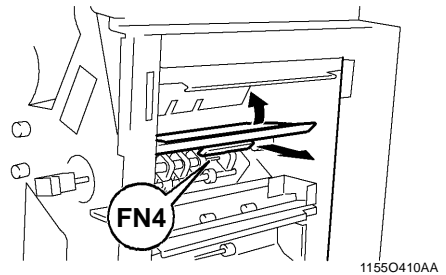

4. When the Message “A paper misfeed has been detected.” Appears

- 14** Turn Knobs **FN7** and **FN6** to feed the sheet of paper.

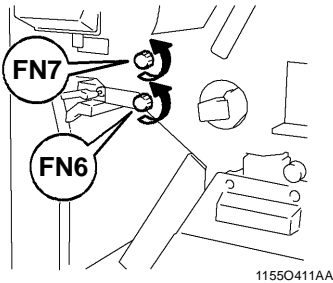

- 15** Pinching the lever of Misfeed Clearing Guide **FN5**, open **FN5**.

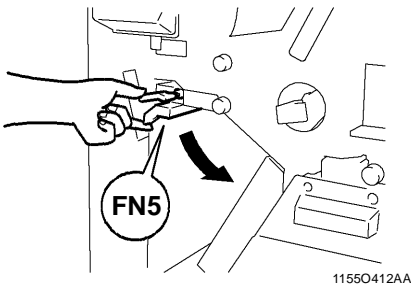

- 16** Remove the sheet of paper and close **FN5**.

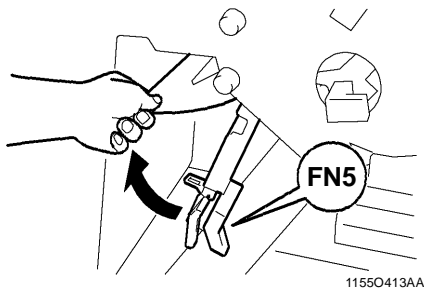

- 17** Slide out Paper Folding Unit **PF2**.

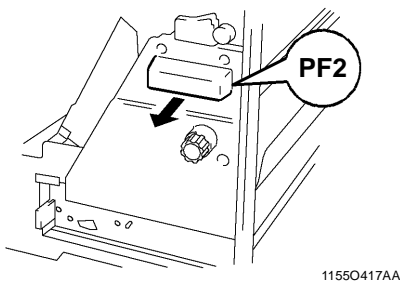

- 18** Opening Misfeed Clearing Guide **PF3**, remove the sheet of paper.

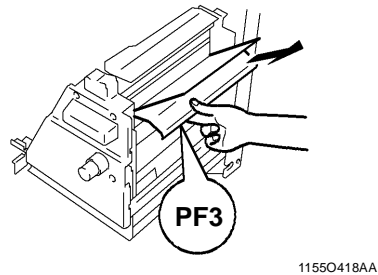

- 19** Raise Misfeed Clearing Guide **PF4**.

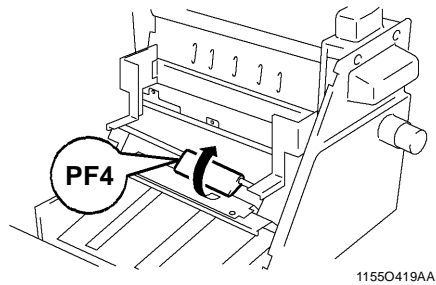

- 20** Turning Knob **PF1**, remove the sheet of paper and then lower Misfeed Clearing Guide **PF4**.

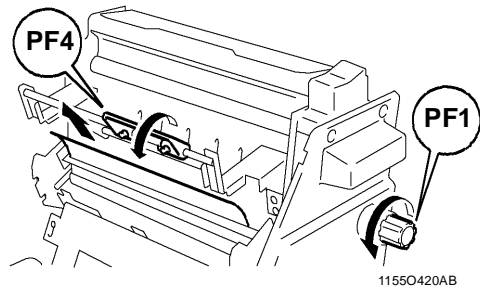

- 21** Opening Misfeed Clearing Guide **PF5**, remove the sheet of paper.

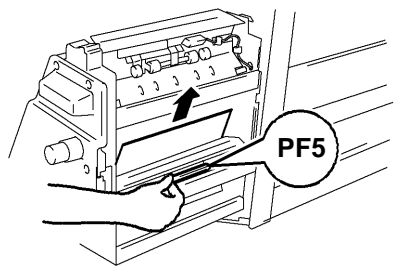

4. When the Message “A paper misfeed has been detected.” Appears

- 22** Opening Misfeed Clearing Guide **PF6**, remove the sheet of paper.

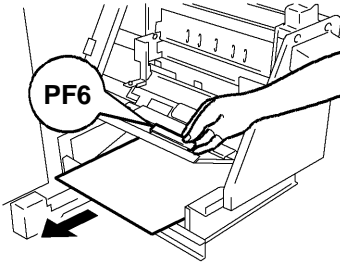

1155O423AA

- 23** Slide Paper Folding Unit **PF2** back into the copier.

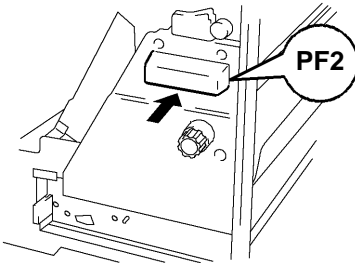

1155O422AA

- 24** Close the Finisher Front Door.

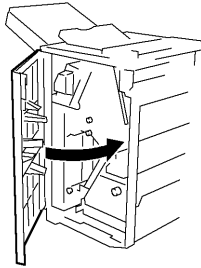

1155O645AA

- 25** Slide the Finisher back against the copier.

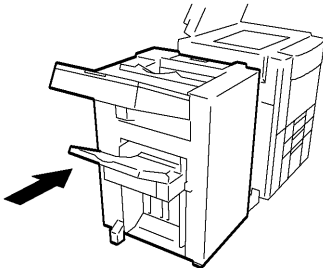

1155O072AA

6. What Does Each Message Mean?

What does each message mean?

Message	Cause	Action
A malfunction was detected. The SMART controller has called your Technical Representative.	The copier malfunctioned and is unable to make copies.	Call and inform your Technical Representative of the code being shown on the Touch Panel.
Please add toner. Follow the instructions on label inside of Front Door.	Toner has run out and the copier is unable to make copies.	Replace the Toner Bottle with a new one. ("When the Message 'Replenish Toner.' Appears" ☞ p. 5-6)
Please add toner.	Toner is soon running out.	Replace the Toner Bottle with a new one. ("When the Message 'Replenish Toner.' Appears" ☞ p. 5-6)
Stapler empty. Replace Staple Cartridge or cancel Staple mode.	The staples have run out.	Replace the Staple Cartridge with a new one. ("When the Message 'The Staple Cartridge is empty.' Appears" ☞ p. 5-8)
Preventative maintenance time.	The time has come when the copier needs service.	Call your Technical Representative.
Your account has reached its maximum copy allowance. Please call your administrator.	The max. number of copies that can be made for your account is determined in the Administrator Mode.	Consult the administrator of your copier. (Administrator Mode of User's Choice ☞ p. 4-19)
Return the following # of originals to Document Feeder: # Sheet(s)	After a misfed sheet of paper has been cleared, you need to reload the originals fed out onto the Document Exit Tray onto the Document Feed Tray.	Add the number of originals indicated to the bottom of the remaining stack and reload.
Image data has caused memory overflow. Your copy job has been canceled.	The copier is unable to scan the data for lack of memory.	Wait until a print cycle is run or erase a reserved job to make room for new data.
Original left on the Glass.	You have left an original on the Original Glass.	Remove the original from the Glass.
This mode cannot be selected with the ○○○.	You have set two functions that conflict with each other.	Cancel either one of the two functions.

Chapter 6

Troubleshooting

1. When This Type of Copy is Produced

When this type of copy is produced

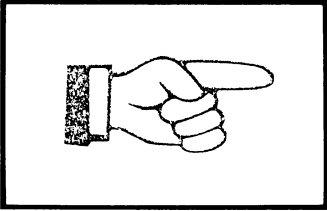
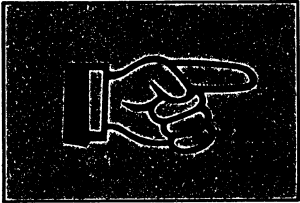
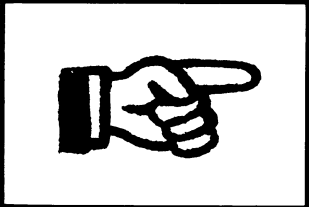
Symptom	Possible Cause	Action
The image is too light.  10740110	The exposure level for the Auto Exposure mode is set at "Lighter."	Change the setting of "Auto Exposure Level" of User's Choice. ☞p. 4-16 Or, cancel the Auto Exposure mode and select Manual Exposure to adjust the exposure level to obtain a darker image. ☞p. 3-43
	The exposure level for the Manual Exposure mode is set at "Lighter."	Touch Darker as necessary to obtain a darker image. ☞p. 3-43
	You have been making copies from a photo or an original with a large dark area.	The copier needs more toner. Replenish toner by using Toner Replenisher of Utility Mode. ☞p. 4-13
	The Toner Bottle has just been replaced.	The copier needs more toner. Replenish toner by using Toner Replenisher of Utility Mode. ☞p. 4-13
	The message "Replenish Toner." is shown on the Touch Panel.	Replace the Toner Bottle. ☞p. 5-6
	The paper is damp.	Change the paper. ☞p. 5-2
The image is too dark.  10740109	The exposure level for the Auto Exposure mode is set at "Darker."	Change the setting of "Auto Exposure Level" of User's Choice. ☞p. 4-16 Or, cancel the Auto Exposure mode and select Manual Exposure to adjust the exposure level to obtain a lighter image. ☞p. 3-43
	The exposure level for the Manual Exposure mode is set at "Darker."	Touch Lighter as necessary to obtain a lighter image. ☞p. 3-43
	The Original Glass surface is dirty.	Wipe the Original Glass clean with a soft dry cloth. ☞p. 7-5
	The original is not held tightly against the Original Glass.	Place the original in position so that it is held tightly against the Original Glass. ☞p. 3-6
The copy is blurry.  10740110	The paper is damp.	Change the paper. ☞p. 5-2

1. When This Type of Copy is Produced

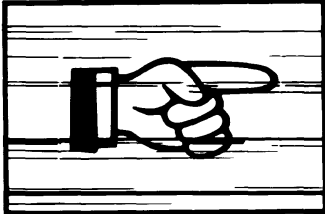
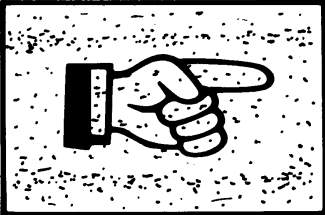
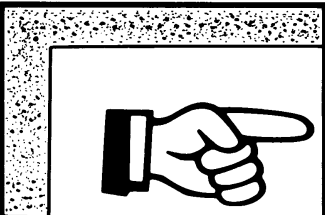
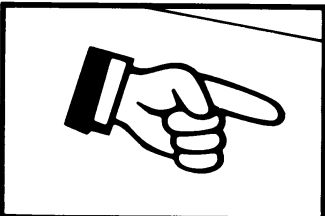
Symptom	Possible Cause	Action
<p>The copy has lines.</p>  <p>1139O1670A</p>	The Original Glass is dirty.	Wipe the Original Glass clean with a soft dry cloth. ☞p. 7-5
	The Original Pad is dirty.	Wipe the Original Pad clean with a soft cloth dampened with alcohol. ☞p. 7-6
	The original is very thin or highly transparent.	Place a blank sheet of paper over the original. ☞p. 3-6
	The original is 2-sided.	The information on the back side of a 2-sided, thin original may be slightly reproduced on the copy. Set the copier into the Manual Exposure mode and, using the Lighter key, make the exposure level lighter. ☞p. 3-43
<p>The copy has dark specks or spots.</p>  <p>1074O111</p>	The Original Pad is dirty.	Wipe the Original Pad clean with a soft cloth dampened with alcohol. ☞p. 7-6
	You have selected a paper size larger than the original. (When Zoom Ratio is set at full size $\times 1.000$)	Select the same copy paper size as the original. ☞p. 3-9 Or, use the Auto Size Mode to enlarge the copy to the appropriate size. ☞p. 3-14
	The original is not placed in the correct position (when the zoom ratio is set at full size $\times 1.000$).	Select the same copy paper size as the original. Or, reload the paper in the same direction as the original. ☞p. 3-9
	The reduction ratio selected is not in accord with the copy paper size. (When doing manual reduction copying.)	Select the zoom ratio according to the copy paper size. ☞p. 3-14 Or, use the Auto Size Mode to reduce the copy to the appropriate size. ☞p. 3-14
<p>The edge of the copy is dirty.</p>  <p>1074O112</p>	The original is not placed in the correct position.	Place the original correctly on the Original Glass against the Original Width Scale. ☞p. 3-6 Or, load it onto the document feeder correctly along the Document Guide Plates. ☞p. 3-5
	The originals may not be suitable for use in the document feeder.	Raise the document feeder and place the originals on the Original Glass one at a time, instead of using the document feeder. ☞p. 3-5
	Something is sticking to the Original Glass.	Wipe the Original Glass clean with a soft dry cloth. ☞p. 7-5
<p>The image on the copy is not aligned properly.</p>  <p>1074O113</p>		

* Call your Technical Representative if these procedures do not correct the problem.

2. The Copier is not Functioning as Designed

The copier is not functioning as designed

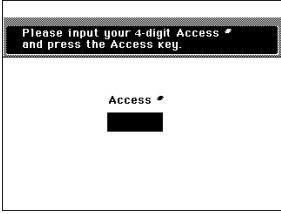
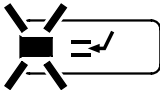
Symptom	Check for	Action
The Touch Panel shows nothing.	Is only the Start key lit up green?	The copier is in the Energy Saver mode. Press any key on the control panel to cancel Energy Saver mode.
	Auto Shut Off is activated.	Turn the Power Switch ON.
	The Display Contrast Knob is turned to the excessively light or dark position.	Viewing the Touch Panel, adjust the Display Contrast Knob as necessary.
The Start key does not light up green.	Is your Access Number or Account Number entered? 	Enter your Access Number or Account Number by following the procedure given in "Entering the Access Number." ☞ p. 2-20
No copies are fed out when the Start key is pressed.	The copier has developed a malfunction.	Check the Touch Panel and take action according to the message on the panel.
	The copier was just turned ON and is warming up.	It takes the copier about 7 min. to be ready for making copies after it has been turned ON. Please wait.
Control panel keys do not respond.	The Interrupt key LED is lit up. 	The copier is in the interrupt mode. Press the Interrupt key to cancel the interrupt mode.
The copier is not activated when the Power Switch is turned ON.	The power cord is left unplugged from the power outlet.	Plug the power cord into the power outlet.
	The room circuit breaker is open.	Close the room circuit breaker.

*If these procedures do not correct the problem, turn OFF the Power Switch, unplug the power cord from the power outlet, and contact your Technical Representative.

Chapter 7

Miscellaneous

1. Specifications

Specifications

Copier 52n/62n

Type	Console Copier
Platen Type	Stationary
Photoconductor	OPC
Copying System	Electrostatic Dry Powdered Image Transfer to Plain Paper
Developing System	Micro-Toning System
Fusing System	Lamp-Heated Roller
Resolution	400dpi
Types of Original	Sheets, Books and other three-dimensional objects Maximum Original Size : 11"×17" Lengthwise Maximum Original Weight : 6-1/2 lbs.
Kinds of Paper	Plain Paper (16 to 24 lbs.), Recycled Paper Exclusive Paper : Thick paper (24-1/4 to 41-3/4 lbs.), OHP transparencies *Exclusive Paper can only be used for the Multi Bypass Tray.
Copy Paper Size	1st Drawer : 11"×17"L to 5-1/2"×8-1/2"L 2nd Drawer : 11"×17"L to 5-1/2"×8-1/2"L 3rd Drawer : LetterC Intelligent Multi Bypass Tray : Crosswise : 4" to 11-3/4" Lengthwise : 5-3/4" to 17"
Paper Feeding System	1st Drawer : 550 sheets (20 lbs.) 2nd Drawer : 550 sheets (20 lbs.) 3rd Drawer : 2, 700 sheets (20 lbs.) Intelligent Multi Bypass Tray : 50 sheets (20 lbs.), 20 sheets (Recycled paper or Exclusive paper)
Warm-Up Time	450 sec. or less
First Copy	LetterC = 6 sec. or less (in full size mode using 1st copier drawer)
Copy Speed (Approx. copies/minute)	Full size (x1.000) 52 ppm: 11"×17"L: 31 LetterL: 48 LetterC: 52 62 ppm: 11"×17"L: 35 LetterL: 48 LetterC: 62
Magnification Ratios	Fixed ratios, Full size: 1:1±0.005 Reduction ratios : ×0.500, ×0.647, ×0.733, ×0.785 Enlargement ratios : ×1.214, ×1.294, ×1.545, ×2.000 Zoom ratios : From ×0.250 to ×4.000 in ×0.001 increments
Multiple Copies	Up to 999 copies (count-down system)
Exposure Control	Auto Exposure Mode, Manual Exposure Mode and Photo Mode
Lost Image	1-sided copy in the full size mode Leading Edge, 3mm Trailing Edge, 3mm Rear Edge, 3mm
Power Requirements	AC120V, 220V-240V; 50/60Hz
Power Consumption	1.5kW or less
Dimensions	Width : 30-1/2" Depth : 29" Height : 38-1/2"
Weight	441 lbs.

Electronic Document Handler EDH-1

Document Feeding System	Standard Mode : 1-sided original, 2-sided original Mixed Original Detection Mode : 1-sided Mixed Original Detection 2-sided Mixed Original Detection Single Feeding Mode : 1-sided original
Kinds of Original	Plain paper 1-sided original Mode : 13-1/4 to 29-1/4 lbs. 2-sided original Mode, Mixed Original Detection Mode: 16 to 24 lbs. Single Feeding Mode : 9-1/4 to 41-3/4 lbs.
Original Size	1-sided, 2-sided original, Single Feeding Mode: 11"×17"L to 5-1/2"×8-1/2"L Mixed original Detection Mode : 11"×17"L to Letter
Capacity of Document Feed Tray	Up to 100 sheets (20 lbs.)
Copy Productivity	100%
Power Source	Supplied from copier
Power Consumption	60W or less
Dimensions	Width : 26-1/4" Depth : 22" Height : 7-1/4"
Weight	37-1/2 lbs.

Large Capacity Cassette C-304

Kinds of Paper	Plain paper (16 to 24 lbs.), Recycled paper
Paper Size	Letter C
Capacity	3,400 sheets (20 lbs.)
Power Source	Supplied from copier
Power Consumption	30W or less
Dimensions	Width : 11-1/2" Depth : 17-1/2" Height : 19-3/4"
Weight	31-1/4 lbs.

Large Capacity Cassette C-304L

Kinds of Paper	Plain paper (16 to 24 lbs.), Recycled paper
Paper Size	LegalL, LetterL, Letter C
Capacity	3,400 sheets (20 lbs.)
Power Source	Supplied from copier
Power Consumption	40W or less
Dimensions	Width : 17-1/4" Depth : 17-1/2" Height : 19-3/4"
Weight	36-1/4 lbs.

1. Specifications

Finisher FN-3

Types of Trays	Top Offset Tray, Bottom Offset Tray
Modes	Non-Sort Mode, Sort Mode, Group Mode, Staple Mode, Hole Punch Mode and Folding Mode
Kinds of Paper	Non-Sort Mode, Sort Mode and Group Mode <ul style="list-style-type: none"> • Plain paper (16 to 24 lbs.), Recycled paper • Exclusive paper: Thick paper, OHP transparencies Staple Mode, Hole Punch Mode and Folding Mode <ul style="list-style-type: none"> • Plain paper (16 to 21-1/4 lbs.), Recycled paper
Capacity of Bins	<ul style="list-style-type: none"> • Plain paper, Recycled paper: Refer to the chart below • Exclusive paper: 10 OHP transparencies (Max. paper size Letter), 10 Thick papers
Punching	Acceptable paper size: 11"×17"L to letter Punch Hole : 2-Hole or 3-Hole
Power Source	Supplied from copier
Power Consumption	96W or less
Dimensions	Width: 36-3/4" Depth: 26-1/4" Height: 43-3/4"
Weight	198-1/2 lbs.
Accessories	Staple Cartridge, 5000 staples/ cartridge x1 piece

		Paper Size	Top Offset Tray	Bottom Offset Tray		#Sheets/ Copy Set	
				Corner Staple	2-Point Staple		
Non-Sort Sort Group		LetterC	100 sheets	2000 sheets (no staple)		-	
		11"×17"L, LegalL, LetterL	100 sheets	1000 sheets (no staple)		-	
		5-1/2"×8-1/2"L, 5-1/2"×8-1/2"C	100 sheets	-		-	
Crisscross Sort		LetterL, LetterC	100 sheets	1000 sheets (no staple)		-	
Staple	Sort Group	Corner	11"×17"L to Letter	-	100 sets or 1000 sheets	-	2 to 50 sheets
		Side	LetterC	-	-	200 sets or 2000 sheets	2 to 50 sheets
	11"×17"L, LegalL, LetterL		-	-	200 sets or 1000 sheets	2 to 50 sheets	
	Center	11"×17"L, LetterL	-	-	100 sets or 1000 sheets	2 to 50 sheets	
Folding	Crease	Staple	11"×17"L, LetterL	-	-	100 sets or 100 sheets	2 to 15 sheets
	Half-Fold	Non-Sort, Sort, Group	11"×17"L	10 sheets	50 sheets (no staple)		-
		Staple	11"×17"L	-	-	100 sheets	2 to 10 sheets
	Z-Fold	Non-Sort, Sort, Group	11"×17"L	10 sheets	50 sheets (no staple)		-
		Staple	11"×17"L	-	100 sheets	100 sheets	2 to 10 sheets
Mixed Orig. Detection	Z-Folded + Unfolded*		11"×17" (Z-Folded) + LetterC	30 sheets	Z-Folded: 100 sheets Z-Folded + Unfolded*: 1000 sheets (no staple)		-
			Z-Folded: 5 sheets/set Unfolded: 2 sheets/set	-	Z-Folded: 100 sheets Z-Folded + Unfolded*: 1000 sheets	Z-Folded: 100 sheets Z-Folded + Unfolded*: 2000 sheets	2 to 30 sheets

* Only 11"×17" size paper can be Z-folded. Therefore, if a stack of mixed-size originals (11"×17" and other sizes) is copied in Mixed Original Detection mode, the copy set will contain a mix of Z-folded and unfolded copies.

2. Care of the Copier

Cleaning

(Turn OFF the Power Switch of the copier when cleaning.)

Housing

- 1 Wipe the surface of the housing clean with a soft cloth dampened with alcohol.

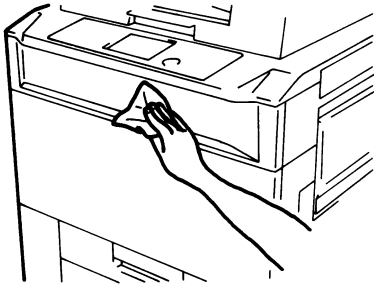

1075O087AA

Original Glass

- 1 Raise the Electronic Document Handler.
- 2 Wipe the surface of the Original Glass clean with a soft, dry cloth.

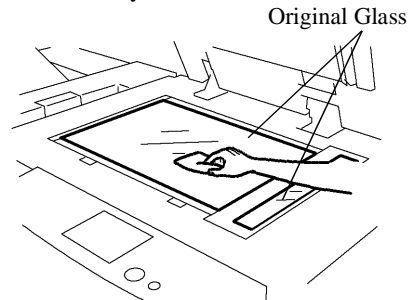

1155O701AA

Control Panel

- 1 Turn the Power Switch OFF.
- 2 Wipe the surface of the Control Panel clean with a soft, dry cloth.

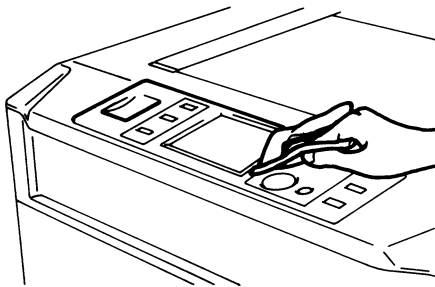

1075O088AA

- 3 Wipe the surface of the guide plate and polyester film (shown below) of the Document Handler clean with a soft, dry cloth.

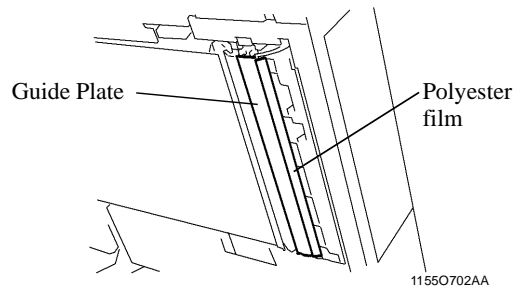

1155O702AA

NOTE

Wipe the film gently as it is fragile.

NOTE

NEVER use a glass cleaner or any detergent to avoid damage to the control panel keys and Touch Panel.

2. Care of the Copier

Original Pad

- 1** Raise the Document Handler.
- 2** Wipe the surface of the Original Pad clean with a soft cloth dampened with alcohol.

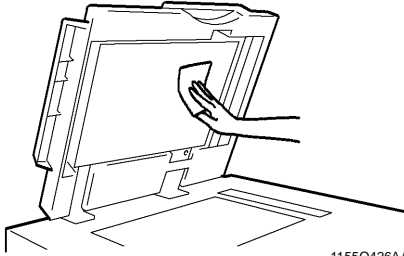

1155O426AA

Front Door

- 1** Swing down the Front Door.
- 2** Wipe the surface of the Front Door clean with a soft, dry cloth.

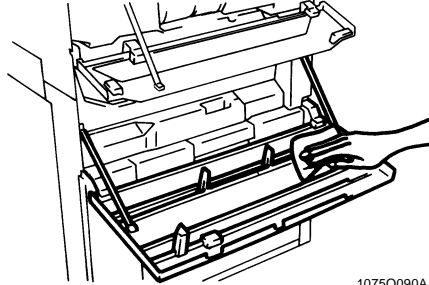

1075O090AA

3. Function Combination Matrix

Function combination matrix

Function Set Last		Basic																				Orig. ▶ Copy							
		Paper				Zoom						Finishing										Orig.	Copy						
		Auto Paper	Manual Paper	Bypass	Exclusive Paper	Auto Size	Full Size	Change Fixed Zoom	Zoom Ratio in Memory	10-Key Input	X/Y Zoom	Non-Sort	Sort	Group	Corner Staple	Side Staple	Center Staple	Hole Punch	Crease	Half-Fold	Z-Fold	1	2	Book	1	2	1 [2in1]		
Function Set First		Auto Paper	Manual Paper	Bypass	Exclusive Paper	Auto Size	Full Size	Change Fixed Zoom	Zoom Ratio in Memory	10-Key Input	X/Y Zoom	Non-Sort	Sort	Group	Corner Staple	Side Staple	Center Staple	Hole Punch	Crease	Half-Fold	Z-Fold	1	2	Book	1	2	1 [2in1]		
Basic	Paper	Auto Paper	×	×	×	×	○	○	○	○	×	○	○	○	○	○	○	○	○	○	○	○	○	○	○	○	○	○	
		Manual Paper	×	×	×	A	○	○	○	○	○	○	○	○	○	○	○	○	○	○	○	×	○	○	○	○	○	○	
		Bypass	×	×	×	A	○	○	○	○	○	○	○	○	○	○	○	○	○	○	○	×	○	○	○	○	○	○	
		Exclusive Paper	×	×	○	○	○	○	○	○	○	○	○	○	○	○	○	○	○	○	○	○	○	○	○	○	○	○	
	Zoom	Auto Size	×	A	A	○	×	×	×	×	×	○	○	○	○	○	○	○	○	○	×	○	○	○	○	○	○	○	
		Full Size	○	○	○	×	×	×	×	×	○	○	○	○	○	○	○	○	○	○	○	○	○	○	○	○	○	○	
		Change Fixed Zoom	○	○	○	×	×	×	×	×	○	○	○	○	○	○	○	○	○	○	○	○	○	○	○	○	○	○	
		Zoom Ratio in Memory	○	○	○	×	×	×	×	×	○	○	○	○	○	○	○	○	○	○	○	○	○	○	○	○	○	○	
		10-Key Input	○	○	○	×	×	×	×	×	○	○	○	○	○	○	○	○	○	○	○	○	○	○	○	○	○	○	
		X/Y Zoom	×	○	○	×	×	×	×	×	○	○	○	○	○	○	○	○	○	○	○	K	×	○	○	○	○	×	
	Finishing	Non-Sort	○	○	○	○	○	○	○	○	○	×	×	×	×	×	×	×	○	○	○	○	○	○	○	○	○	○	
		Sort	○	○	○	○	○	○	○	○	○	×	×	×	×	×	×	×	○	○	○	○	○	○	○	○	○	○	
		Group	○	○	○	○	○	○	○	○	○	×	×	×	×	×	×	×	○	○	○	○	○	○	○	○	○	○	
		Corner Staple	○	○	×	○	○	○	○	○	○	×	×	×	×	×	×	×	○	○	I	L	○	○	○	○	○	○	
		Side Staple	○	○	×	○	○	○	○	○	○	×	×	×	×	×	×	×	○	J	L	○	○	○	○	○	○	○	
		Center Staple	○	○	×	○	○	○	○	○	○	×	×	×	×	×	×	×	○	L	L	○	○	○	○	○	○	○	
		Hole Punch	○	○	×	○	○	○	○	○	○	○	○	○	○	○	○	○	○	○	○	○	○	○	○	○	○	○	
		Crease	○	○	×	○	○	○	○	○	○	○	○	○	○	○	○	○	○	○	○	○	○	○	○	○	○	○	
		Half-Fold	○	○	×	○	○	○	○	○	○	○	○	○	○	○	○	○	○	○	○	○	○	○	○	○	○	○	
	Z-Fold	○	●	●	-	●	○	○	○	○	○	○	○	○	○	○	○	○	○	○	○	○	○	○	M	○	○	○	
	Orig. Copy	Orig.	1	○	○	○	○	○	○	○	○	○	○	○	○	○	○	○	○	○	○	○	○	○	○	○	○	○	○
			2	○	○	○	○	○	○	○	○	○	○	○	○	○	○	○	○	○	○	○	○	○	○	○	○	○	○
			Book	○	○	○	○	○	○	○	○	○	○	○	○	○	○	○	○	○	○	M	○	○	○	○	○	○	○
		Copy	1	○	○	○	○	○	○	○	○	○	○	○	○	○	○	○	○	○	○	○	○	○	○	○	○	○	○
			2	○	○	×	○	○	○	○	○	○	○	○	○	○	○	○	○	○	○	○	○	○	○	○	○	○	○
			1 [2in1]	○	○	○	○	○	○	○	○	○	○	○	○	○	○	○	○	○	○	○	○	○	○	○	○	○	○
			2 [2in1]	○	○	×	○	○	○	○	○	○	○	○	○	○	○	○	○	○	○	○	○	○	○	○	○	○	○
			1 [4in1]	○	○	○	○	○	○	○	○	○	○	○	○	○	○	○	○	○	○	○	○	○	○	○	○	○	○
2 [4in1]			○	○	×	○	○	○	○	○	○	○	○	○	○	○	○	○	○	○	○	○	○	○	○	○	○	○	
Booklet Creation			○	○	×	○	○	○	○	○	○	○	○	○	○	○	○	○	○	○	○	○	○	○	○	○	○	○	
Original Direction			○	○	○	○	○	○	○	○	○	○	○	○	○	○	○	○	○	○	○	○	○	○	○	○	○	○	
Margin			○	○	○	○	○	○	○	○	○	○	○	○	○	○	○	○	○	○	○	○	○	○	○	○	○	○	
Page Arrange	○	○	×	○	○	○	○	○	○	○	○	○	○	○	○	○	○	○	○	○	○	○	○	○	○	○			
Auxiliary	Cover	○	○	○	○	○	○	○	○	○	○	○	○	○	○	○	○	○	○	○	○	○	○	○	○	○	○		
	Page Insertion	○	○	○	○	○	○	○	○	○	○	○	○	○	○	○	○	○	○	○	○	○	○	○	○	○	○		
	OHP Interleaving	B	○	○	○	○	○	○	○	○	○	○	○	○	○	○	○	○	○	○	○	○	○	○	○	○	○		
	File Margin	○	○	○	○	○	○	○	○	○	○	○	○	○	○	○	○	○	○	○	○	○	○	○	○	○	○		
	Edge/Frame Erase	○	○	○	○	○	○	○	○	○	○	○	○	○	○	○	○	○	○	○	○	○	○	○	○	○	○		
	Image Repeat	●	○	○	○	○	○	○	○	○	○	○	○	○	○	○	○	○	○	○	○	○	○	○	○	○	○		
	Date Stamping	○	○	○	○	○	○	○	○	○	○	○	○	○	○	○	○	○	○	○	○	○	○	○	○	○	○		
	Page Numbering	○	○	○	○	○	○	○	○	○	○	○	○	○	○	○	○	○	○	○	○	○	○	○	○	○	○		
	Distribution Numbering	○	○	○	○	○	○	○	○	○	○	○	○	○	○	○	○	○	○	○	○	○	○	○	○	○	○		
	Image Stamping	○	○	○	○	○	○	○	○	○	○	○	○	○	○	○	○	○	○	○	○	○	○	○	○	○	○		
Mixed Orig. Detection	Mixed Orig. Detection	○	○	○	○	○	○	○	○	○	○	○	○	○	○	○	○	○	○	○	○	○	○	○	○	○	○		
	Separate Scan	○	○	○	○	○	○	○	○	○	○	○	○	○	○	○	○	○	○	○	○	○	○	○	○	○	○		
	Small Orig. Adjustment	○	○	○	○	○	○	○	○	○	○	○	○	○	○	○	○	○	○	○	○	○	○	○	○	○	○		
	Free Orig. Placement	○	○	○	○	○	○	○	○	○	○	○	○	○	○	○	○	○	○	○	○	○	○	○	○	○	○		

4. Description of Paper Size and Zoom Ratio Table

Description of paper size and zoom ratio table

Paper Size

Name	Size (Metric)	Size (Inch)
A3	297mm×420mm	11-3/4" × 16-1/2"
B4	257mm×364mm	10" × 14-1/4"
A4	210mm×297mm	8-1/4" × 11-3/4"
B5	182mm×257mm	7-1/4" × 10"
A5	148mm×210mm	5-3/4" × 8-1/4"
B6	128mm×182mm	5" × 7-1/4"
A6	105mm×148mm	4-1/4" × 5-3/4"
POST CARD	100mm×148mm	4" × 5-3/4"

Name	Size (Inch)	Size (Metric)
LEDGER	11" × 17"	279mm×432mm
11"×14"	11" × 14"	279mm×356mm
COMPUTER	10-1/8" × 14"	257mm×356mm
10"×14"	10" × 14"	254mm×356mm
9-1/4"×14"	9-1/4" × 14"	236mm×356mm
LEGAL	8-1/2" × 14"	216mm×356mm
FOOLSCAP	GOVERNMENT LEGAL	8-1/2" × 13"
FOOLSCAP		8" × 13"
FOOLSCAP		8-2/3" × 13"
FOOLSCAP	FOLIO	8-1/4" × 13"
8-1/4"×11-3/4"	8-1/4" × 11-3/4"	210mm×301mm
LETTER	8-1/2" × 11"	210mm×279mm
GOVERNMENT LETTER	8" × 10-1/2"	203mm×267mm
QUARTO	8" × 10	203mm×254mm
STATEMENT	INVOICE	5-1/2" × 8-1/2"
		140mm×216mm

Zoom Ratio Table (Original Size to Copy Paper Size)

Original Size	Metric Areas	
	Copy Paper Size	Zoom Ratio
A3 297×420mm 11-3/4"×16-1/2"	A4	×0.707
	A5	×0.500
	B4	×0.866
	B5	×0.610
	A5	×0.707
A4 210×297mm 8-1/4"×11-3/4"	A6	×0.500
	B5	×0.866
	B6	×0.610
	A3	×1.414
	B4	×1.224
A5 148×210mm 5-3/4"×8-1/4"	A6	×0.707
	B6	×0.866
	A4	×0.414
	A3	×2.000
	B4	×1.733
A6 105×148mm 4-1/4"×5-3/4"	B5	×1.224
	A4	×2.000
	A5	×1.414
	B5	×1.733
B4 257×364mm 10"×14-1/4"	B6	×1.224
	A4	×0.816
	A5	×0.577
	B5	×0.707
B5 182×257mm 7-1/4"×10"	B6	×0.500
	A3	×1.154
	A5	×0.816
	A6	×0.577
B6 128×182mm 5"×7-1/4"	B6	×0.707
	A3	×1.640
	A4	×1.154
	B4	×2.000
	B5	×1.414

Original Size	Metric Areas	
	Copy Paper Size	Zoom Ratio
11"×17" 279.4×431.8mm	11"×14"	×0.823
	Legal	×0.772
	Foolscap	×0.764
	Letter	×0.647
	Invoice	×0.500
11"×15" 279.4×381mm	11"×14"	×0.933
	Legal	×0.772
	Foolscap	×0.772
	Letter	×0.733
	Invoice	×0.500
11"×14" 279.4×355.6mm	Legal	×0.772
	Foolscap	×0.772
	Letter	×0.772
	Invoice	×0.500
	Foolscap	×0.928
Legal 8-1/2"×14" 215.9×355.6mm	Letter	×0.785
	Invoice	×0.607
	11"×17"	×1.214
Foolscap 8-1/2"×13" 215.9×330.2mm	Letter	×0.846
	Invoice	×0.647
	11"×17"	×1.294
Letter 8-1/2"×11" 215.9×279.4mm	11"×14"	×1.076
	Invoice	×0.647
	11"×17"	×1.294
Invoice 5-1/2"×8-1/2" 139.7×215.9mm	11"×14"	×1.272
	11"×17"	×2.000
	11"×14"	×1.647
	Legal	×1.545
Foolscap	Letter	×1.529
	Letter	×1.294

Zoom Ratio = Copy Paper Size ÷ Original Size

1"(Inch) = 25.4mm
1mm = 0.0394"(Inch)

Index

Numeric

100 Accounts	4-19
1000 Accounts	4-19
10-Key Pad	2-14
▶1	3-35
▶1 (2in1)	3-35
▶1 (4in1)	3-36
▶12	3-35
▶12 (2in1)	3-35
▶12 (4in1)	3-36
▶1Booklet Creation	3-36
1st Drawer	5-2
▶21	3-35
▶21 (2in1)	3-35
▶21 (4in1)	3-36
▶22	3-35
▶22 (2in1)	3-35
▶22 (4in1)	3-36
▶2Booklet Creation	3-36
2in1, 4in1, Booklet Copy Zoom	4-16
2nd Drawer	5-3
3rd Drawer	5-4
4in1 Copy Order	4-17

A

Access Mode Key	2-14
Access Number	2-20
Adding paper	5-2
Administrator Mode	4-19
Auto Copy Start	2-19
Auto Drawer Switching	3-10
Auto Dual Function	3-34
Auto Exposure	3-43
Auto Panel Reset	2-19
Auto Paper/Auto Size	4-15
Auto Shut OFF	2-19
Auto Size	3-14

B

Book1	3-36
Book2	3-36
BookBooklet	3-36

C

Calling up a Ratio from Memory	3-17
Cleaning	7-5
Clear Key	2-14
Clearing Counters for Each Account	4-28
Confirmation Beep	4-18
Control Panel	2-8
Copy Paper Size	3-9
Copy Track	4-19

Copy Track Data	4-23
Cover	3-45
Crisscross Grouping	3-22
Crisscross Sorting	3-22

D

Date/Time Set	4-19
Default Level	4-16
Deleting a Job Program	4-4
Description of Paper Size and Zoom Ratio Table . 7-10	
Display Contrast Knob	2-15

E

Edge/Frame Erase	3-57
Energy Saver	2-19
Exposure Priority	4-16

F

File Margin	3-55
Folding	3-21
Function combination matrix	7-7

G

Group	3-20
-------------	------

H

Half-Fold	3-29
-----------------	------

I

Image Density	3-43
Image Memory Input	4-8
Image Repeat	3-59
Image Stamping	3-65
Initial Mode	2-18
Intelligent Sorting	4-16
Interrupt	2-20
Interrupt Key	2-14

J

Job List	3-72
Job Memory Input	4-2

L

Language Selected	4-15
Large Capacity Cassette	5-5
Loading the Originals	3-5

M

Making Different Types of Copy	3-75
Making the User's Choice Settings	4-21
Manual Bypass Copying	3-11
Manual Exposure	3-43
Manual Staple	3-26
Margin	3-38

Index

Max. Copy Set	4-20	Staple	3-21
Memory Recall	3-70	Start Key	2-14
Meter Count	4-13	Stop Key	2-14
Misfeed Clearing Procedures	5-12	Storing a Ratio in Memory	3-18
Misfeed Location Displays	5-10	T	
Mixed Orig. Detection	3-67	Toner Replenisher	4-13
Mixed Original Detect	4-15	Total Counter	4-13
Mode Check	2-20	Touch Panel	2-14
Mode Check Key	2-15	Tray Priority	4-15
N		Turning ON and OFF	2-18
Non-Auto Shut Off	4-19	U	
Non-Sort	3-20	User's Choice Functions	4-14
Number Stamping	3-61	Using Zoom Up/Down Key	3-15
O		Utility Key	2-15
OHP Interleaving	3-51	Utility Mode	4-1
Original Direction	3-37	W	
OriginalCopy Default	4-15	What does each message mean?	5-28
P		X	
Page Insertion	3-47	X / Y Zoom	3-16
Panel Reset Key	2-14	Z	
Panel Resetting	2-19	Z-Fold	3-30
Photo	3-44	Zoom Memory Input	4-6
Plug-In Counter Reset	4-18	Zoom Ratio	3-14
Print Exposure	4-19		
Priority Device	4-19		
Priority Offset Tray	4-19		
Programming the Access Code	4-24		
R			
Recalling a Job from Memory	4-5		
Replacing the Staple Cartridge	5-8		
Replacing the Toner Bottle	5-6		
Reserve	3-71		
S			
SADF Mode	3-8		
Selecting Free Original Placement	3-68		
Selecting Separate Scan	3-69		
Selecting Small Original Adjustment	3-68		
Selecting the Finishing Function	3-22		
Selecting the Fixed Zoom	3-14		
Setting a Copy Limit for Each Account	4-26		
Setting the Copy Track Function	4-22		
Shift Grouping	3-22		
Shift Sorting	3-22		
Size Counter	4-13		
“Small” Originals	4-17		
Sort	3-20		
Special Paper Setting	3-10		
Specifications	7-2		

