

AP 360

AP 362

LABEL APPLICATOR

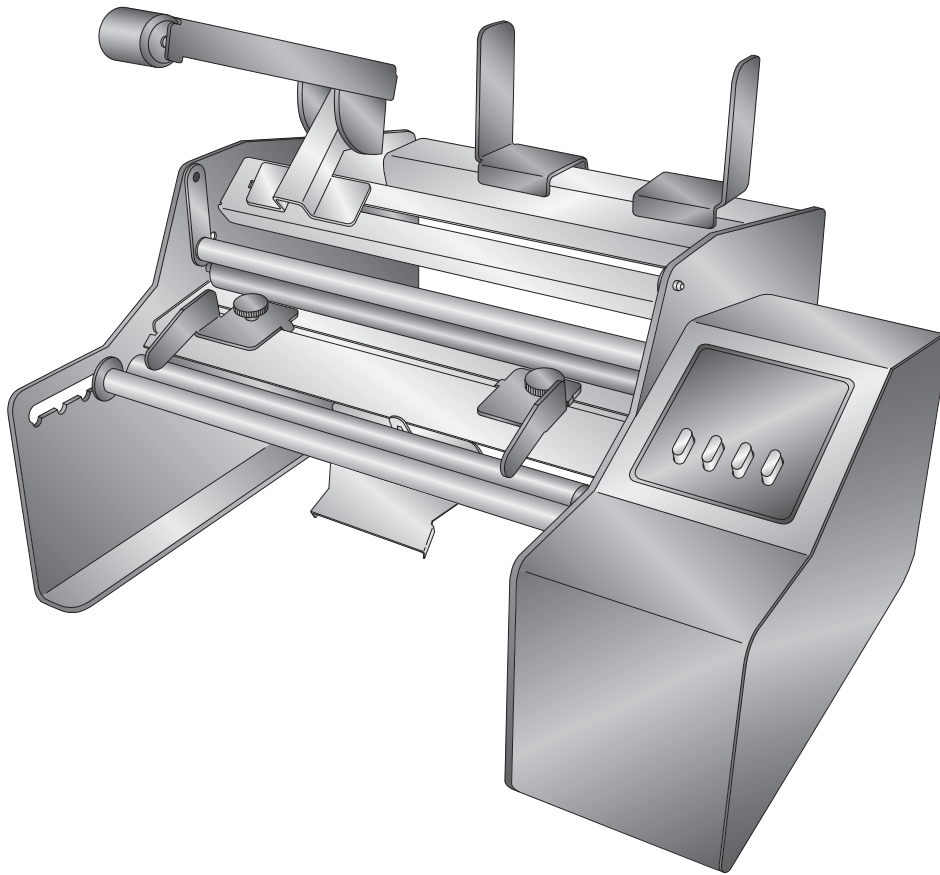

Unpacking and Setup	3
Loading the Label Stock	4
Loading the Container	9
Applying the Label	12
Label Path Diagram	15
Troubleshooting and Maintenance	16
Specifications	18

PRIMERA

© 2009 All rights reserved

Quick Start

Notices: The information in this document is subject to change without notice. NO WARRANTY OF ANY KIND IS MADE WITH REGARD TO THIS MATERIAL, INCLUDING, BUT NOT LIMITED TO, THE IMPLIED WARRANTIES OF MERCHANTABILITY AND FITNESS FOR A PARTICULAR PURPOSE. No liability is assumed for errors contained herein or for incidental or consequential damages in connection with the furnishing, performance, or use of this material. This document contains proprietary information that is protected by copyright. All rights are reserved. No part of this document may be photocopied, reproduced, or translated into another language without prior written consent.

Trademark Acknowledgments: Windows is a registered trademark of Microsoft Corporation. All other trademarks are the property of their respective owners.

Printing History

Edition 1.3, #091709, Copyright 2009, All rights reserved.

FCC Compliance Statement: This device complies with part 15 of the FCC rules. Operation is subject to the following two conditions: (1) this device may not cause harmful interference, and (2) this device must accept any interference received, including interference that may cause undesired operation.

For Users in the United States: This product is intended to be supplied by a UL listed Direct Plug-In Power Supply marked "Class 2" or a UL listed ITE Power Supply marked "LPS" with output rated 12VDC, 4.5A or higher. This equipment has been tested and found to comply with the limits for a Class A digital device, pursuant to Part 15 of the FCC Rules. In a domestic environment this product may cause radio interference, in which case the user may be required to take adequate measures. This equipment generates, uses, and can radiate radio frequency energy and, if not installed and used in accordance with the instructions, may cause harmful interference to radio communications. However, there is no guarantee that interference will not occur in a particular installation. If this equipment does cause harmful interference to radio or television reception, which can be determined by turning the equipment off and on, the user is encouraged to try to correct the interference by one or more of the following measures:

- Re-orient or relocate the receiving antenna.
- Increase the separation between the equipment and receiver.
- Connect the equipment into an outlet on a circuit different from that to which the receiver is connected.
- Consult the dealer or an experienced radio/TV technician for help.

Use of shielded cables is required to comply with the Class A limits of Part 15 of the FCC Rules. You are cautioned that any changes or modifications not expressly approved in this manual could void your authority to operate and/or obtain warranty service for this equipment.

For Users in Canada: This digital apparatus does not exceed the Class A limits for radio noise for digital apparatus set out on the Radio Interference Regulations of the Canadian Department of Communications. Le présent appareil numérique n'émet pas de bruits radioélectriques dépassant les limites applicables aux appareils numériques de la class A prescrites dans le Règlement sur le brouillage radioélectrique édicté par le ministère des Communications du Canada.

General Safety Information.

Note: Notes are used to notify of installation, operation, or maintenance information that is important but not safety related.

Caution: Caution is used to indicate the presence of a hazard, which if ignored may result in damage to the unit.

Warning: Warning means that a potential safety hazard exists and indicates procedures that must be followed exactly to avoid serious personal injury.

 **WARNING!**
TO PREVENT FIRE OR SHOCK HAZARD, DO NOT EXPOSE THE UNIT TO RAIN OR MOISTURE. TO REDUCE THE RISK OF ELECTRIC SHOCK, DO NOT REMOVE EXTERIOR PANELS. NO USER-SERVICEABLE PARTS INSIDE. REFER SERVICING TO QUALIFIED SERVICE PERSONNEL. OPERATE THE UNIT WITH ONLY THE PROPER ELECTRICAL SPECIFICATIONS AS LABELED ON THE PRINTER AND AC ADAPTER.

 **WARNING!**
DO NOT WEAR LOOSE FITTING CLOTHING SUCH AS NECK TIES OR LOOSE LONG SLEEVES WHEN OPERATING THE AP360/362. THE MOTOR IS VERY POWERFUL AND THE LINEr DRIVE ROLLER COULD CATCH THE CLOTHING WHILE THE LABELS ARE BEING APPLIED.

Section 1: Unpacking and Setup

Thank you for purchasing the AP360 or AP362 Label Applicator (hereafter referred to as "Label Applicator"). Bottles, cans etc. will collectively be referred to as "containers." This manual applies to two label applicator models. The AP362 has a Control Panel that allows you to count labels and apply two labels to the same container. The AP360 does not have a Control Panel or two-label capability.

The Label Applicator includes a Power Cord, 12 volt Power Adapter and the parts shown in *Figure 1-1*. The Roll Bar, Roll Guides and Roll Drag Arm are located in the supply box along with the Power Cord. You will need to assemble them as shown in *Figure 1-1*. Attach the Power Cord and switch on the power as shown in *Figure 1-2*. Feed the Foot Switch and Foot Switch cord out through the front of the Label Applicator. Remove the tape securing the Container Rollers.

Figure 1-1.

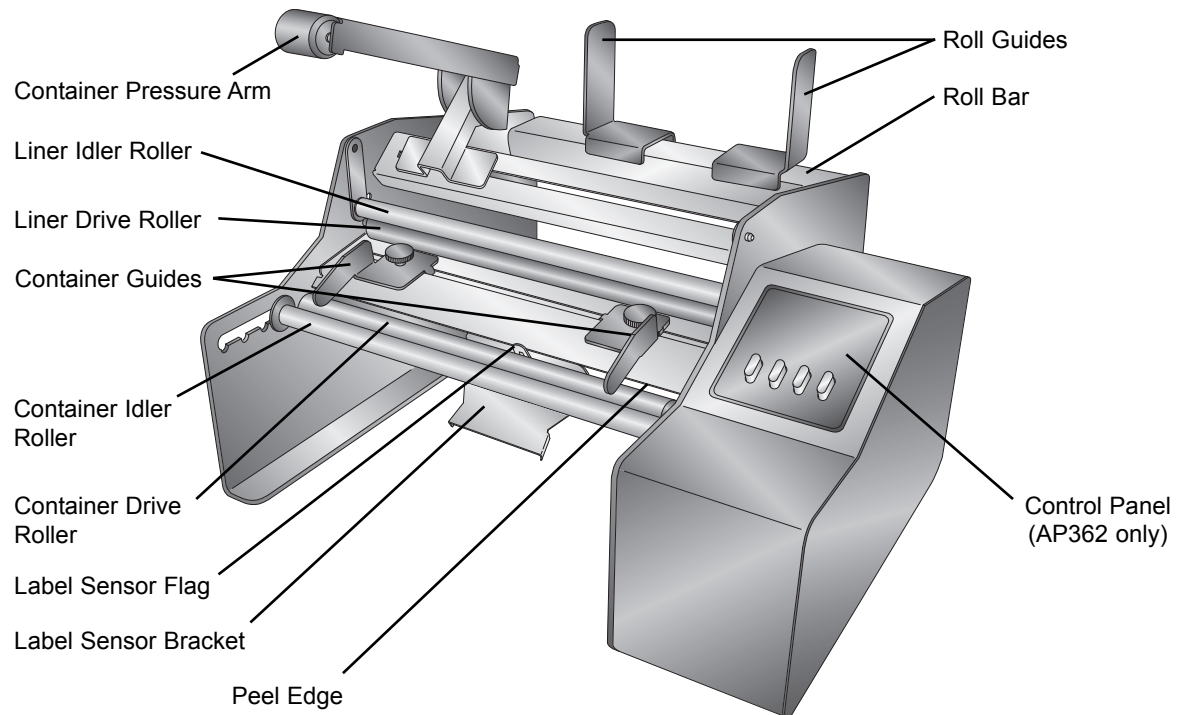
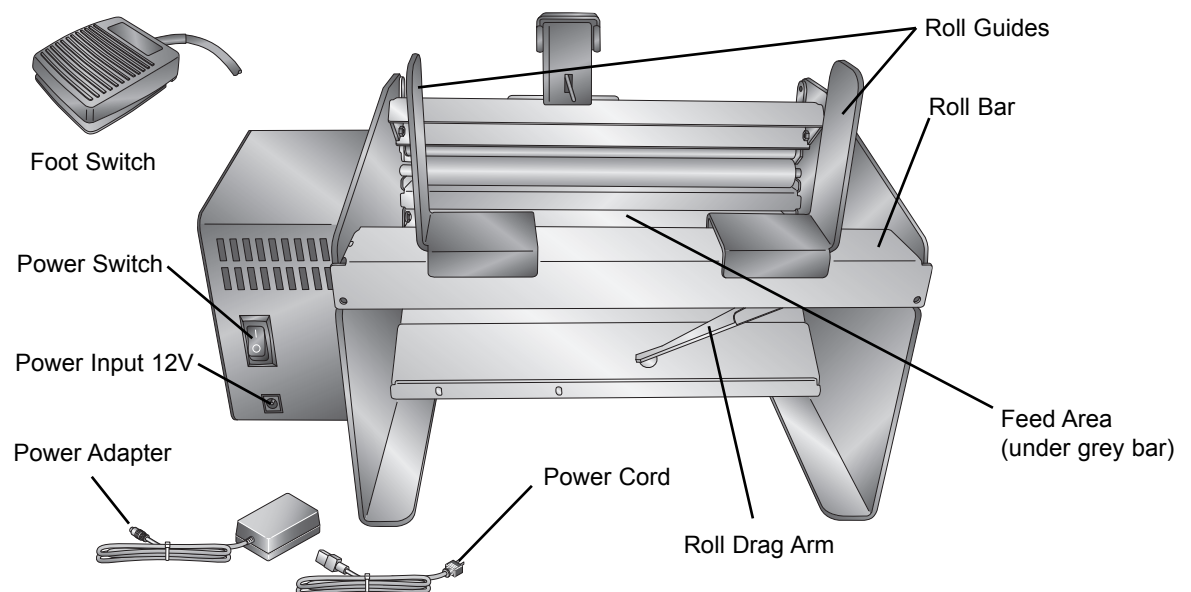

Figure 1-2.



Section 2: Loading the Label Stock

1. Remove the Roll Bar and Roll Guides from the Label Applicator. The Roll Guides and Roll Drag Arm are removable and adjustable. They are held in place magnetically. (*Figure 2-1.*)

Figure 2-1.

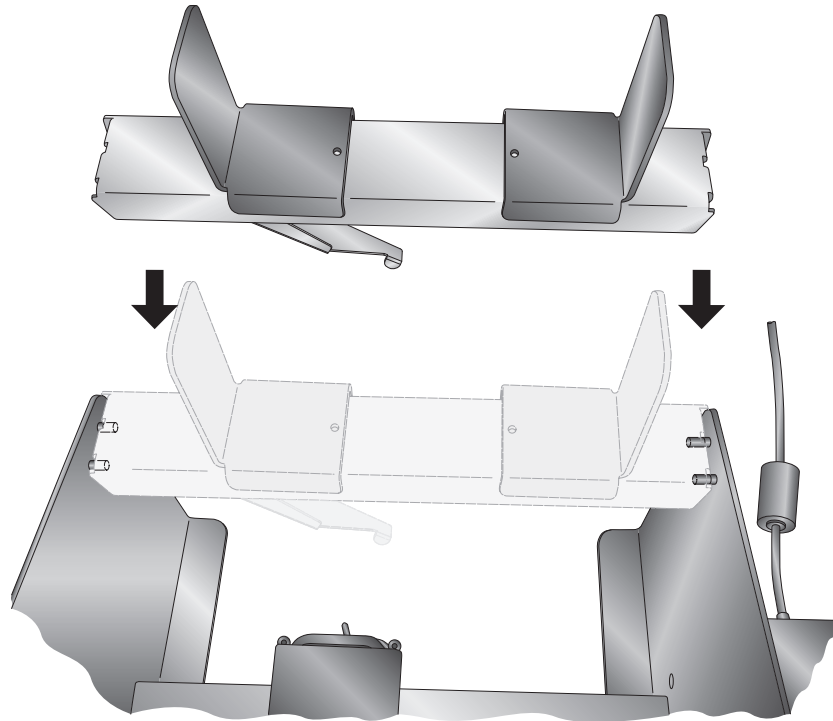

2. Remove one Roll Guide and the Roll Drag Arm from the Roll Bar.
3. Place the label stock roll on the Roll Bar with one side against the upright of the remaining Roll Guide. Place it on the Roll Bar with the loose end of the stock feeding underneath the roll. (*Figure 2-2.*)

Figure 2-2.

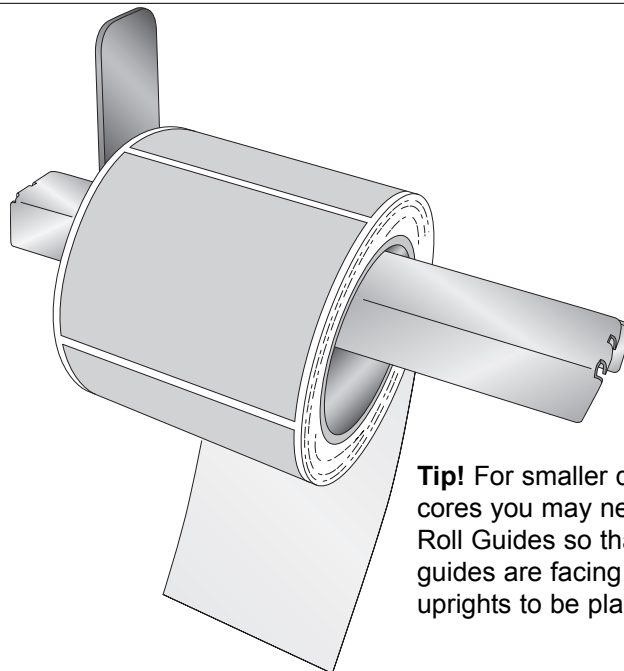

Tip! For smaller diameter label roll cores you may need to reverse the Roll Guides so that the bottom of the guides are facing out to allow the uprights to be placed next to the roll.

4. Place the Roll Drag Arm under the Roll Bar. The Roll Drag Arm may be placed on either side of the Roll Bar but the rounded tip of the Roll Drag Arm should be located in the center of the inside of the core. The arm is spring loaded so that there is downward pressure on the inside of the roll. This helps prevent application alignment problems near the end of a roll. (Figure 2-3.)

Figure 2-3.

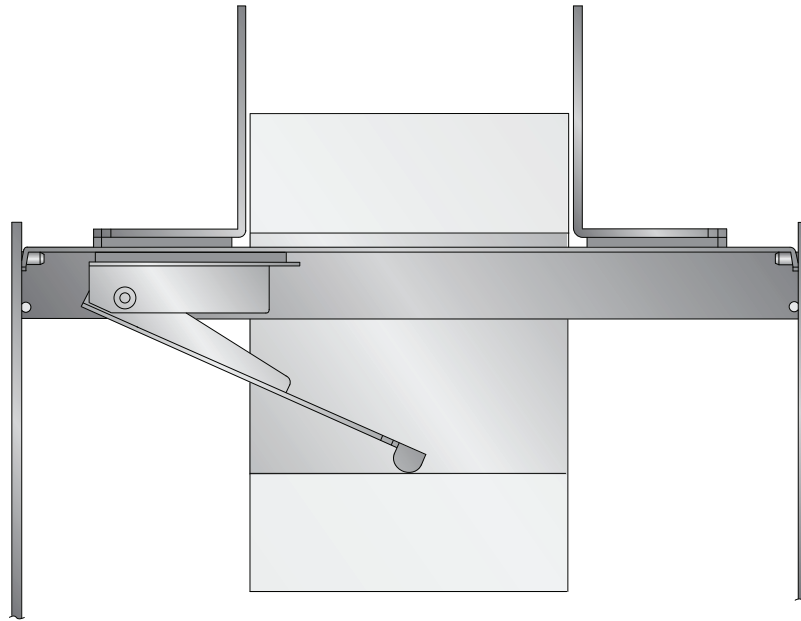

5. Place the removed Roll Guide back on the Roll Bar and slide it close to, but not touching the label stock roll. (Figure 2-4.)

Figure 2-4.

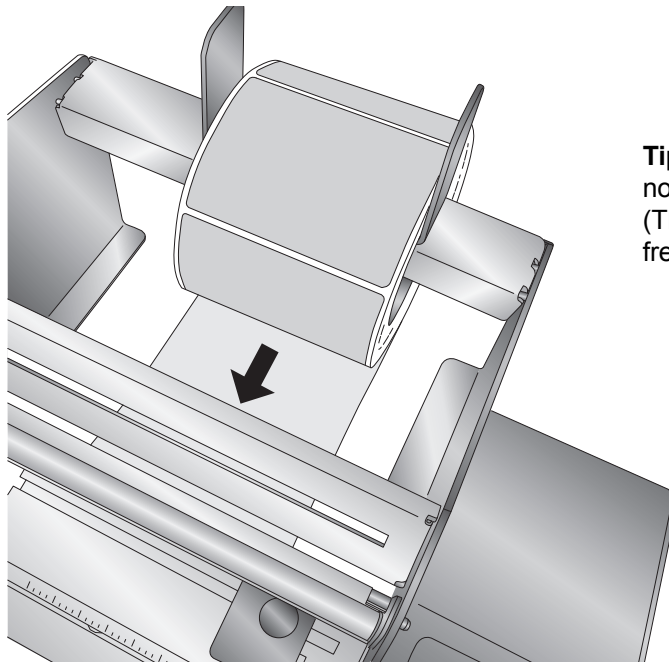

Tip! Roll Guide Uprights must not pinch the label stock roll. (The label stock roll must have free-play between guides.)

6. Now position the stock to correspond with the general area where it will be applied to the container.
7. Pull the loose end of the label stock forward and then push it into the Feed Area from the back of the label applicator. The labels will come out just underneath the Peel Edge. (*Figure 2-5.*)

Figure 2-5.

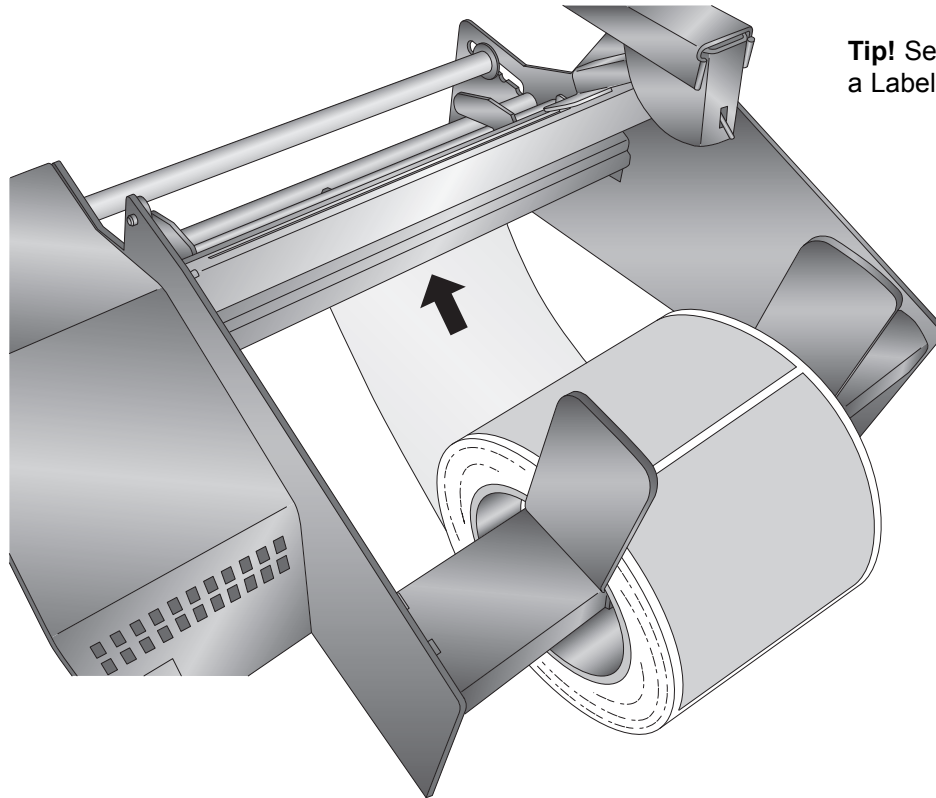

Tip! See Section 5 for a Label Path diagram.

8. Pull approximately 12 inches of label stock out beyond the Peel Edge. (*Figure 2-6.*)

Figure 2-6.

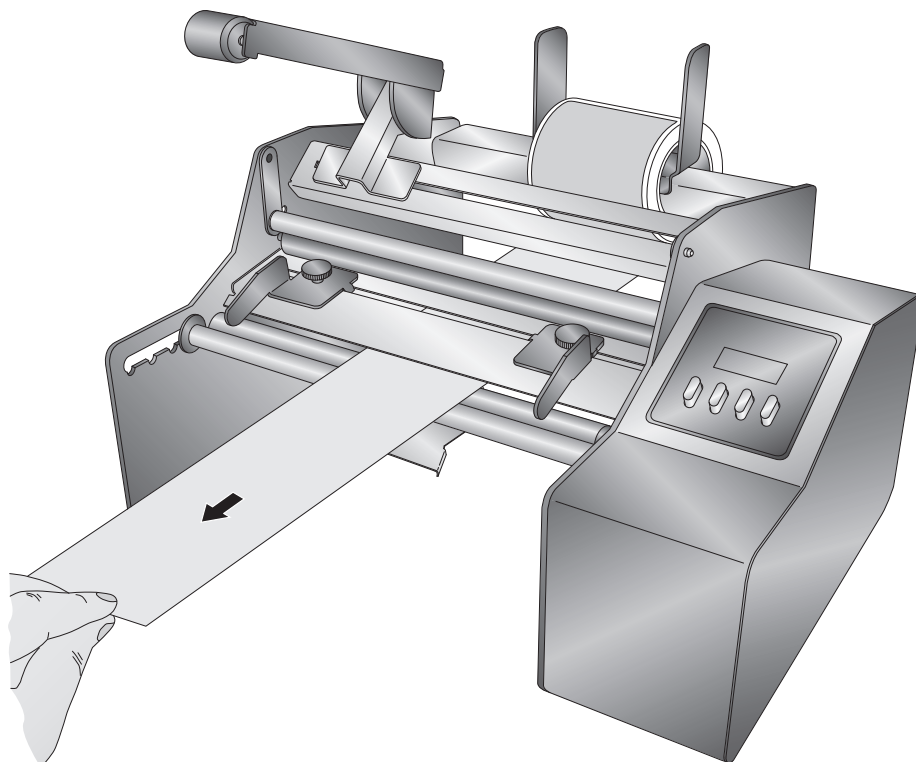

9. Take the loose label stock and feed it between the Liner Idler Roller and the Liner Drive Roller. (*Figure 2-7.*) In order to feed the label stock between the rollers, the Liner Idler Roller should be in the unclamped position. For some thicker label stock, it may be necessary to remove the labels from the liner before performing this step. (*See Figure 2-10 for a detailed diagram of the Liner Idler Roller positions.*)

Figure 2-7.

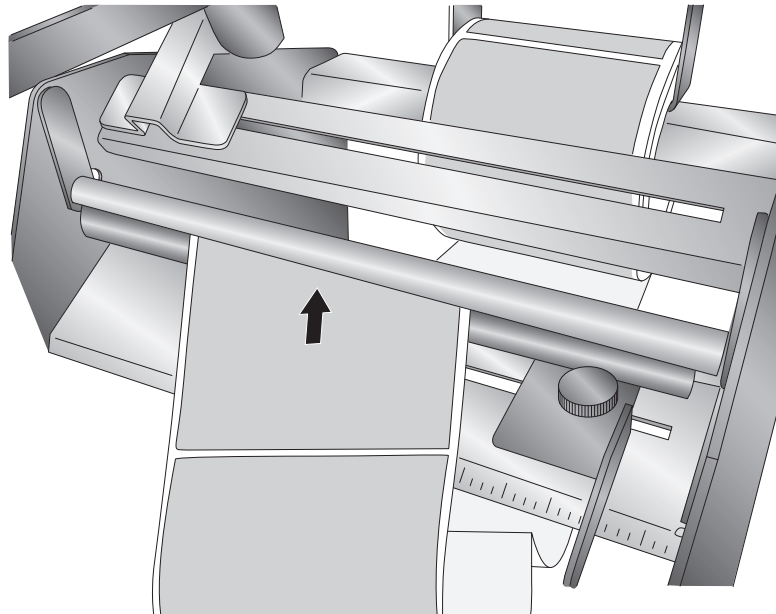

Note: This procedure assumes that the first 12 inches of labels will not be applied to the container using the Label Applicator. Of course, you may still apply these labels by hand.

10. Pull the stock all the way through until the end of the roll is laying over the top of the label stock roll. Adjust the label stock forward or backward so that the Peel Edge is between two labels. (*Figure 2-8.*)

Figure 2-8.

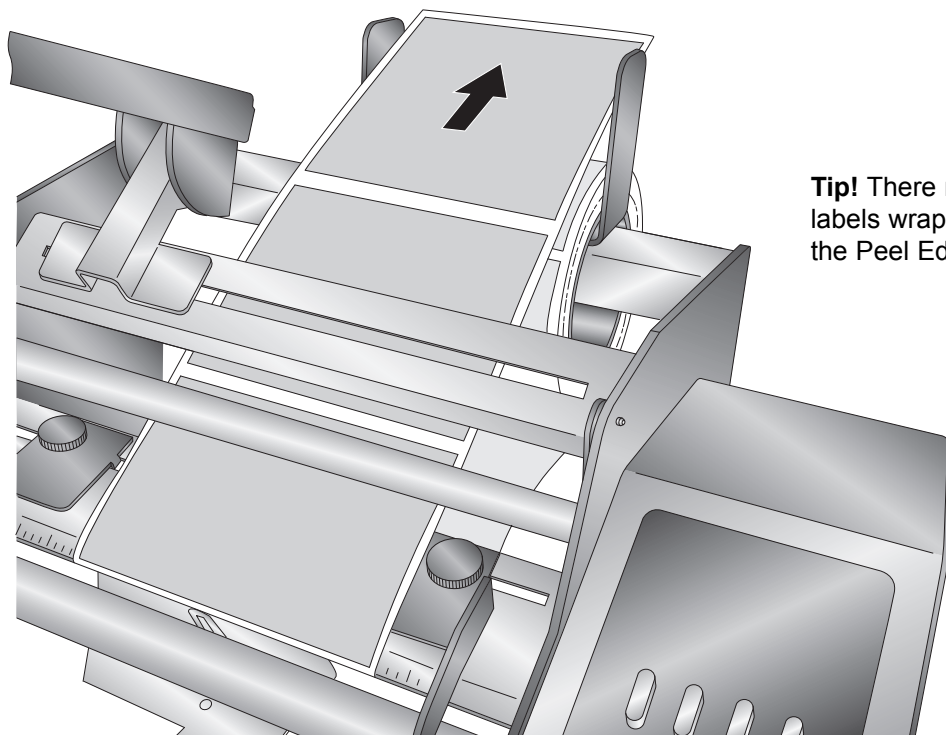

Tip! There must be no labels wrapped around the Peel Edge.

11. If necessary, adjust the position of the liner on the Peel Edge left/right to align the liner with the label stock roll. Also, adjust the Label Sensor using the Label Sensor Bracket so that the Label Sensor Flag is roughly centered on the label stock. (Figure 2-9.)

Figure 2-9.

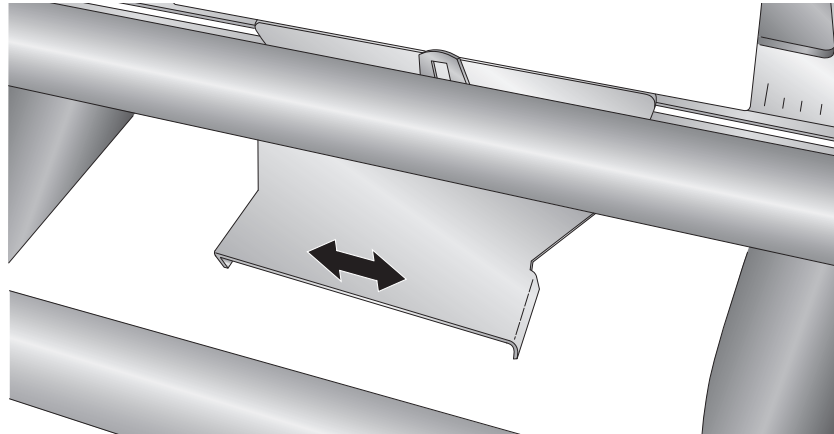

12. Push the Liner Idler Roller into the clamped position. (Figure 2-10.)

Figure 2-10.

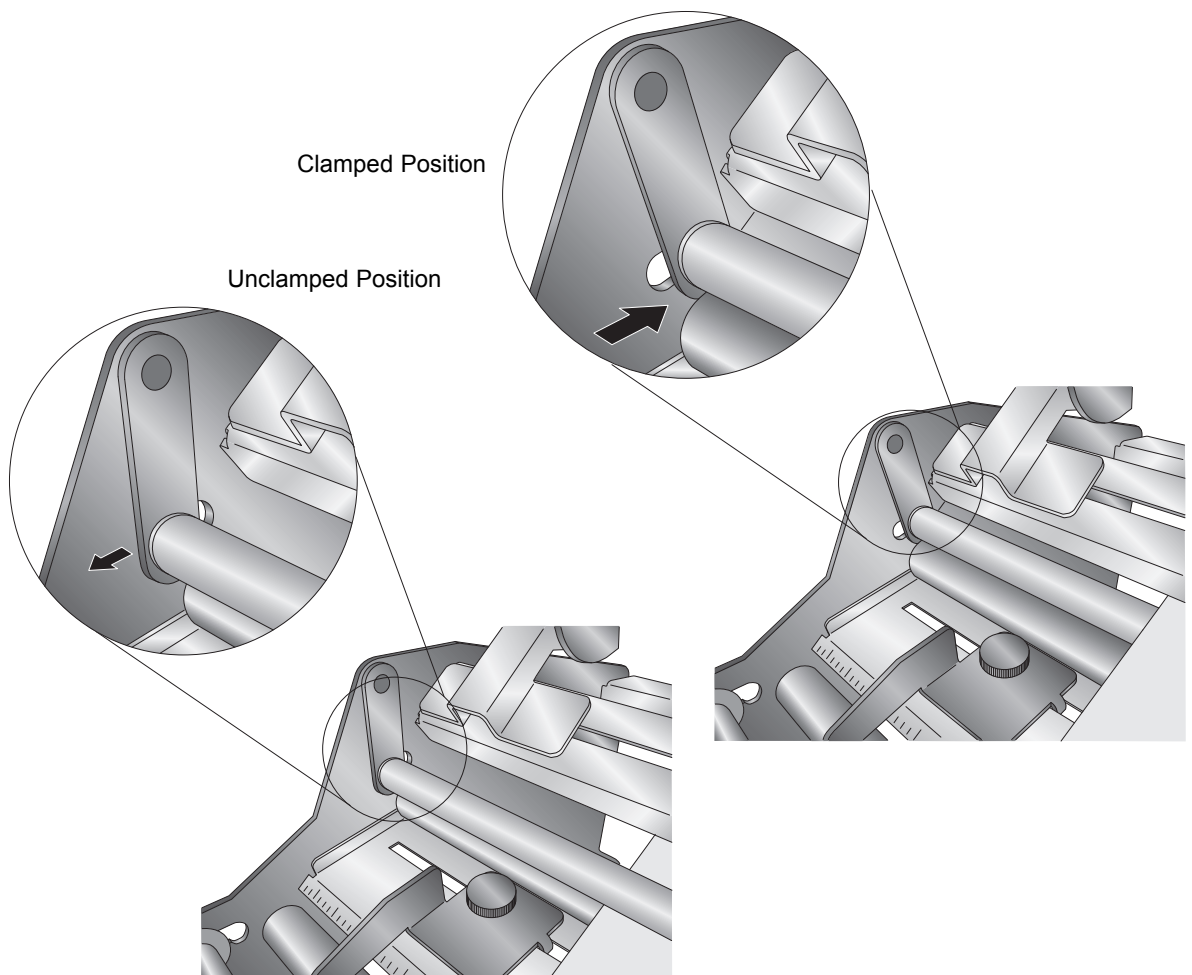

13. The labels are now ready for application.

Note: Position the Label Applicator on the edge of a table so that the liner falls to the floor. This will prevent excess labels from interfering with label applications.

Section 3: Loading the Container

The AP360/362 can apply labels to a variety of containers including wine bottles, soda bottles, jars, cans, etc. Depending on the container type that you are labeling, you have several different options. You may use the Container Pressure Arm to hold the containers against the rollers, but that may not be necessary. You may use one or both of the Container Guides. Use these steps as a guide for applying labels. Ultimately, you will find the method that is fastest for you, which may or may not include use of the Container Pressure Arm and/or one or both Container Guides.

1. Lift the Container Pressure Arm to a height well above the imagined height of the container. (*Figure 3-1.*)

Figure 3-1.

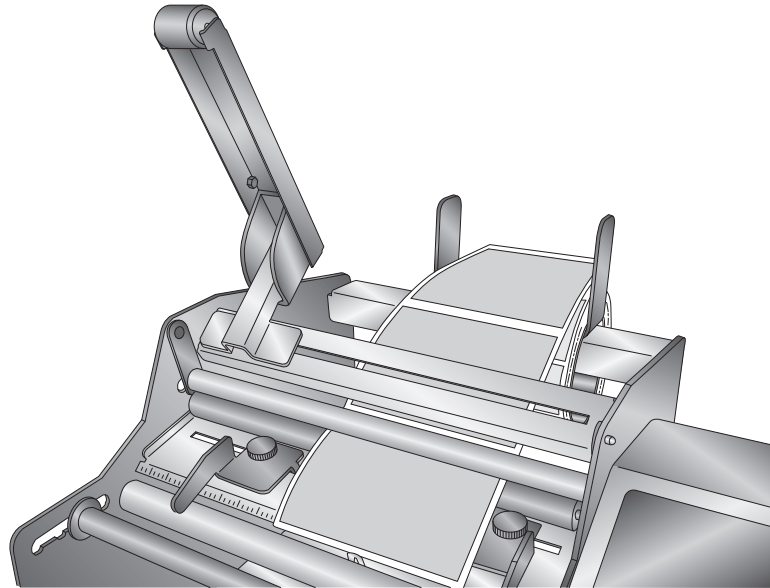

2. Position the Container Idler Roller so that the container is at the highest possible position that is still stable. There are four optional positions for the Container Idler Roller provided by the notches in the side plates. If the Container Idler Roller is spaced too far from the Container Drive Roller the container will be positioned too low for the label to be applied. This will cause the label to fold, wrinkle, or eject above the container. The smaller the diameter of the container, the closer the rollers need to be positioned to each other. (*Figure 3-2.*)

Figure 3-2.

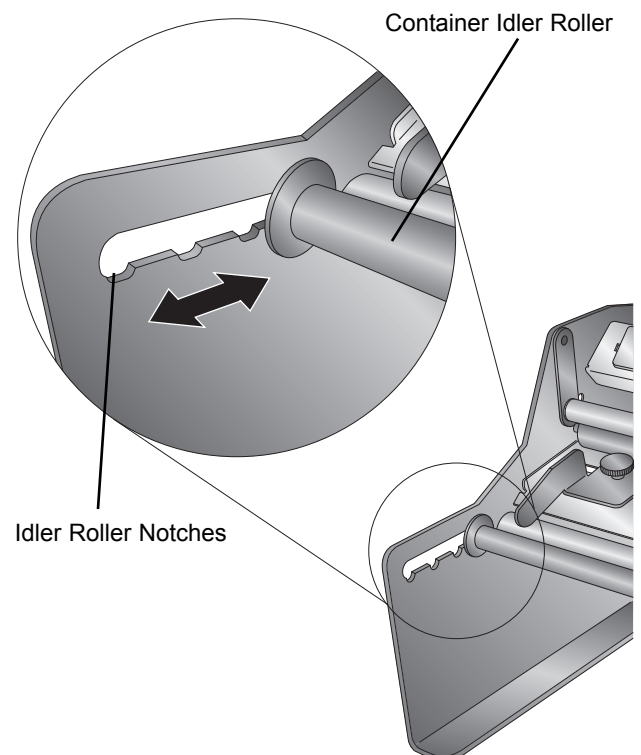

3. Place the container on the Container Idler Roller and Container Drive Roller. Orient the container with the top to the left or the right, depending on the orientation of your labels on the label stock roll. (Figure 3-3.)

Figure 3-3.

Tip! Both Container Guides may be used, but for maximum efficiency, typically only one is used to position the container.

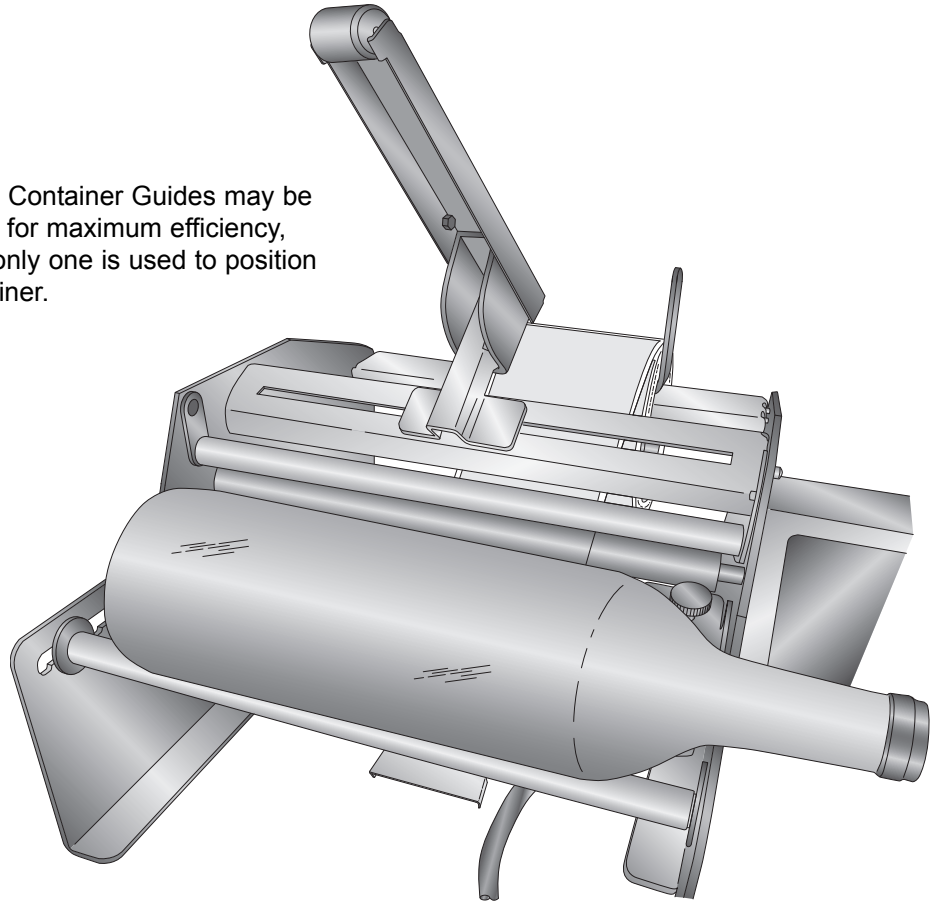

4. Adjust the Container Guides so the labels will be placed in the desired location on the container. Since it is difficult to get the label stock in the same position each time, we recommend that you adjust the container relative to the label stock using the Container Guides. If you have several containers that have different labels for each it may be useful to record the distance between the edge of the label stock and the container guides for each job using the Position Scale. (Figure 3-4.)

Figure 3-4.

5. Once the Container Guides are in the correct position use the Thumb Screws to secure them in place.

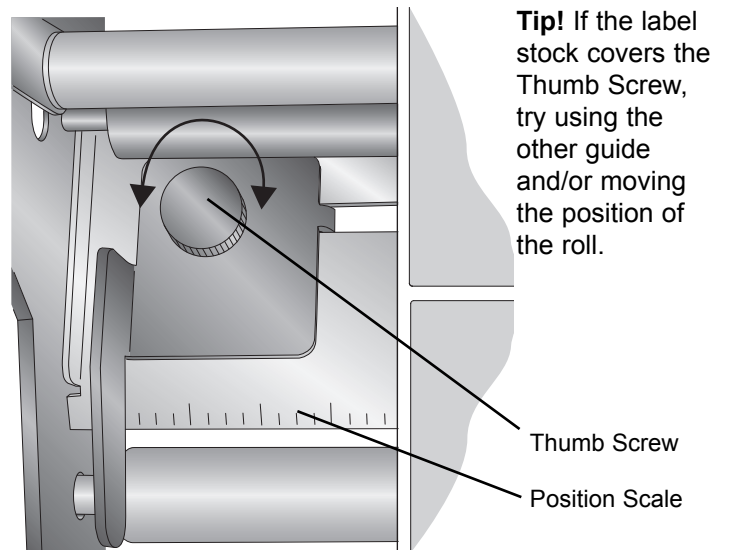

Important Note: For bottles with a neck such soda, beer or wine bottles only one Container Guide can be used. Move the unused Container Guide to the far right or left side of the labeling area. For cans or other containers that do not have a tapered neck, both Container Guides can be used, if desired.

6. With the container in place, move the Container Pressure Arm right or left until it is roughly centered on the container. Push down on the arm until the roller on the end of the arm touches the container. Remove the container. Push down the arm approximately 1/2 inch more. Attempt to place the container back on the rollers. The goal is to easily be able to place the container, yet still have sufficient downward pressure on the container. This downward pressure is more important for smaller, lighter containers such as pill bottles. The Container Pressure Arm is optional for larger and/or heavier bottles such as wine bottles.
(Figure 3-5.)

Figure 3-5.

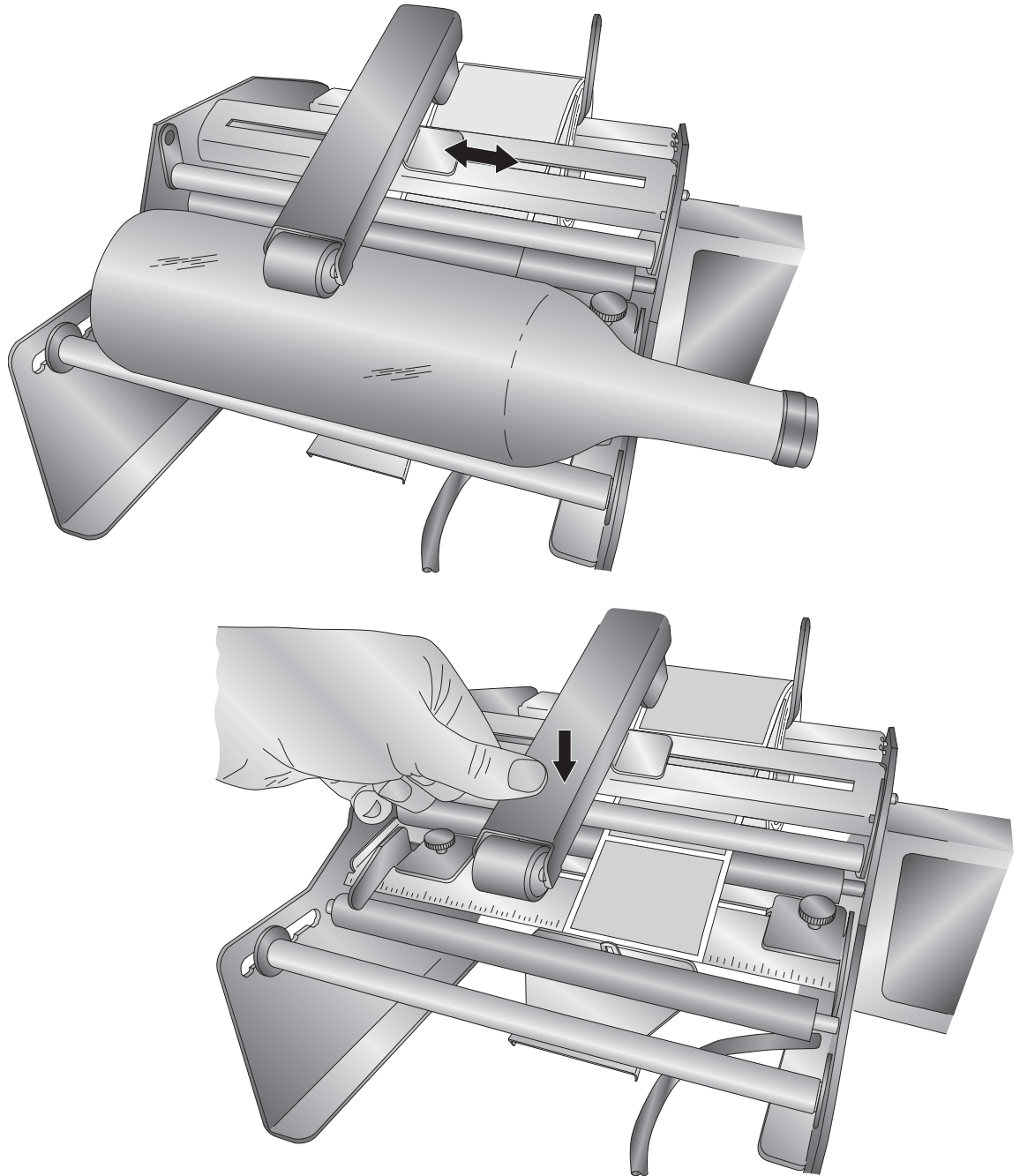

Section 4: Applying the Label

A. Apply the Label

1. Power on the Label Applicator using the Power Switch. This can be done at any point with or without the container in place.
2. Place the container on the rollers using the instructions in Section 3.

Important Note: For label stock 6" and wider, it may be necessary to reduce the speed of the Label Applicator. The AP360/362 includes a half-speed mode that generates more power from the motors for wider label stock. To activate this mode, hold down the Foot Switch while switching on the unit. The AP360/362 will revert back to the default mode when switched on without holding down the Foot Switch.

3. Press the Foot Switch to apply the label.
4. Remove the container. The rollers will continue to spin the container for fifteen minutes after each application. If you need to make an adjustment, do so now.
5. While the rollers are still spinning, place the next container on the rollers and press the Foot Switch.
6. Continue this process until all containers are labeled.

B. Apply two labels to the same container (AP362 only)

The AP362 has the ability to apply two labels to the same container. Using the control panel you may also adjust the distance between the two labels. Nine different distances can be saved in the unit's memory. These distances are represented by nine different memory locations: F1 - F9. (F-0 represents the single label application mode.) By choosing the desired memory location/ distance you can easily switch between multiple two-label containers without having to readjust label distances.

Follow this procedure to apply two labels to each container:

Important Note: In order for two label mode to work the two labels must be printed one after another on the same roll of stock.

1. Press the Mode Button once to display the current memory location.
2. While in the memory mode, press the Recall/Reset Button repeatedly to move to the desired memory location (F1 - F9). (Press Recall/Reset repeatedly to move back to F0 for single-label mode.) (Figure 4-1.)
3. The desired memory location (F1 - F9) will be displayed for 2 seconds, followed by the current value set for that memory location for another 8 seconds. During this time, press the + or - Button to adjust the distance value to be set for this memory location. (Figure 4-2.)

Hold down the button to move more quickly through the values. Once the value is set it will be displayed for 8 seconds and then stored in memory. The screen will then revert to label counter mode. The value displayed corresponds to inches. The unit accepts values between 0.01 and 9.99 inches (0.25 mm to 253.7 mm).

For metric versions of the AP362 the value displayed corresponds to centimeters. The unit accepts values between 00.1 cm (1mm) and 25.4 cm.

Figure 4-1.

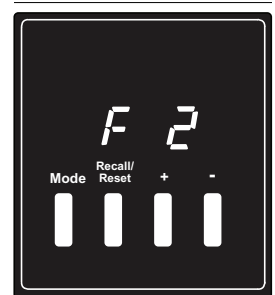
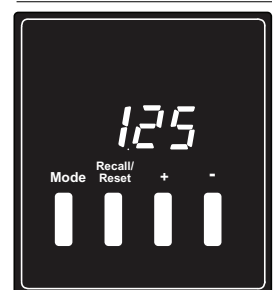

Figure 4-2.



4. Press the Foot Switch to apply the labels. Both labels will be applied without pressing the Foot Switch again.

To set a value for another memory location, repeat this procedure.

Note: *The distance values are approximate. Adjusting the position of the Container Idler Roller will affect the actual distance between the labels on the container.*

C. Calculate distances for two-label mode.

If you intend to apply two labels to the same container you will typically want to center the second label so that you have the same distance between each label on both sides. Use this formula to calculate the proper distance setting (see Section 4B).

1. First Calculate the circumference of your container.

$$\text{diameter of container} \times \pi = \text{circumference}$$

2. Now subtract the width of both front and back labels from the circumference and divide by two.

$$(\text{circumference} - \text{width of front label} - \text{width of back label}) / 2$$

3. Subtract the distance between the labels on the liner (the distance between the labels while they are still attached to the roll) from the value received in step 2.

Example:

If your bottle is 3 inches in diameter, your front label is 4 inches wide, your back label is 2.5 inches wide, and the distance between the labels on the liner is .12, the distance value to enter would be 1.34 inches.

$$3 \times \pi = 9.42$$

$$(9.42 - 4 - 2.5) / 2 = 1.46 - 0.12 = 1.34$$

Note: *The value given by this formula is a good starting point. Some adjustments may be needed depending on the particular container and the Container Idler Roller position.*

D. Count labels (AP362 Only)

By default the AP362 Label Applicator will begin to count labels. This count will be displayed on the LCD. If you press any of the buttons on the control panel the label count will momentarily disappear. It will reappear ten seconds after the button is pressed. (Figure 4.3.)

Press and hold the Recall/Reset Button for five seconds to reset the label counter to zero.

Note: *The label counter will reset to zero if power is switched off.*

Figure 4-3.

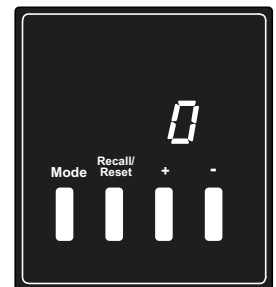

E. Change the Unit of Measure between Metric and English.

The AP362 can display measurements in both centimeters and inches. Follow these steps to switch between the two.

English (Inches):

1. Turn off the unit.
2. Press and hold both the "Mode" button and the "+" button while you switch on the unit.
3. While the unit is booting up a "-" will appear as the first digit of the firmware version number on the display.

Metric (Centimeters):

1. Turn off the unit.
2. Press and hold both the "Mode" button and the "-" button while you switch on the unit.
3. While the unit is booting up a "=" will appear as the first digit of the firmware version number on the display.

F. Set the Mode of Container Roller Motor:

By default the container rollers continue to spin after every application. This is done to increase application speeds. However, using this method it is not possible to apply the label at a specific point on the container. To do this you can put the unit in Stop After Apply mode. See the instructions below:

Run After Apply (Default):

1. Turn off the unit.
2. Press and hold the Recall button with the '+' key and turn on the unit.

Stop After Apply:

1. Turn off the unit.
2. Press and hold the Recall button with the '-' key and turn on the unit.

Label Path Diagram

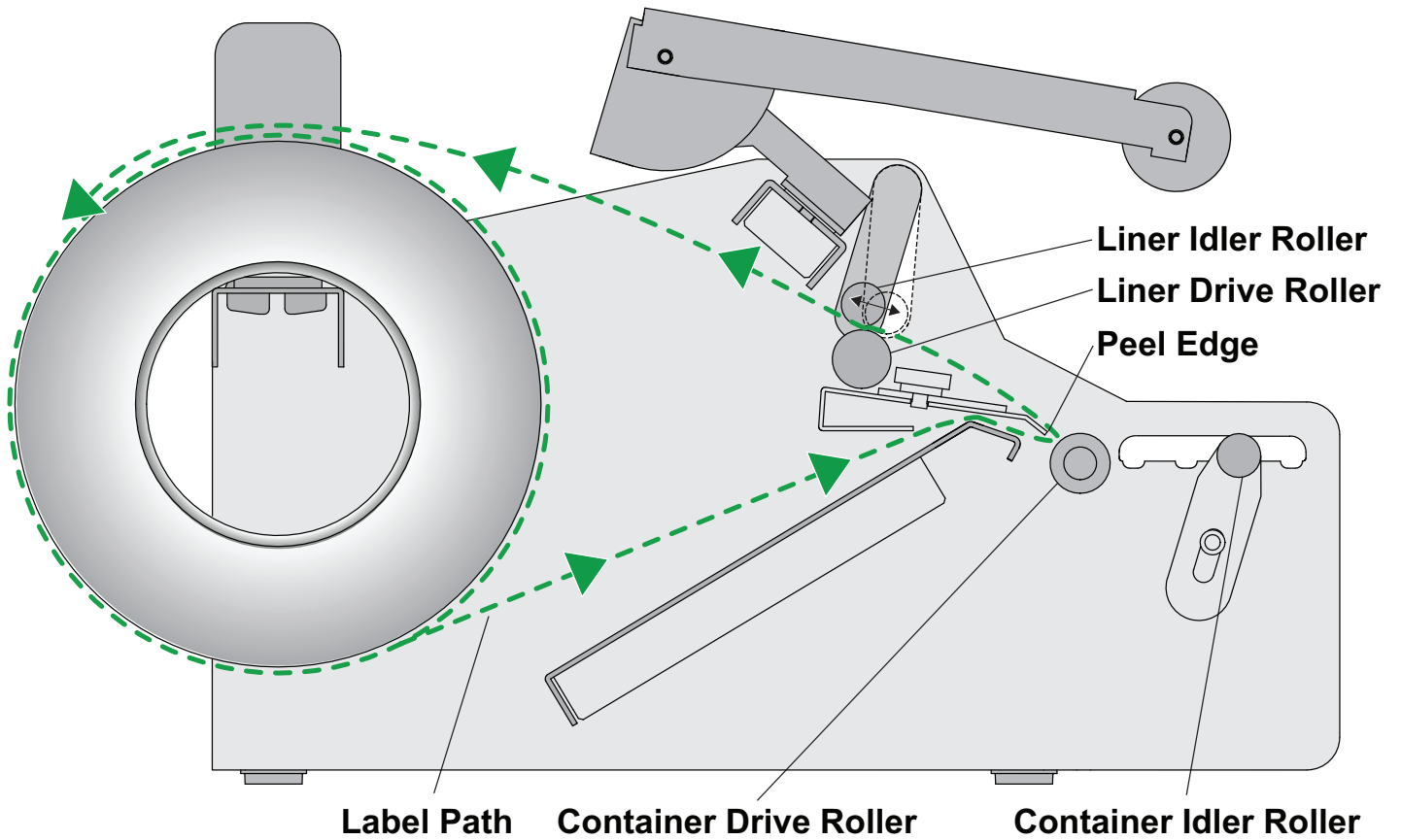

Section 6: Troubleshooting and Maintenance

Troubleshooting

Labels are applied to the container crooked.

1. Check for container taper. Some containers such as wine bottles may have a slight taper that will cause the label to be applied crooked. You may be able to apply your label straight if you angle the container idler roller to correspond with the angle of the taper. For example, if you normally apply labels to the bottle with both sides of the container idler roller in the third notch from the drive roller, try putting one side in notch three and the other side in notch four.
2. Roll Guides should also be positioned very close to the roll, but not squeezing any part of the roll (so the roll has very little play side-to-side between the guides).
3. It may take several labels to allow the label stock to “straighten-out” or “settle-in” where it will run for the duration of the roll. It will “settle-in” quicker if you make sure to get the label stock loaded relatively square to the roll.
4. For larger heavier rolls make sure that the roll is positioned on top of the Roll Guides with the magnetic portions facing in. This will minimize the chances that the heavy roll will push the guides out of place.
5. For lighter rolls make sure the Roll Drag Arm is in place as described in the manual. If you do not have a Roll Drag Arm please contact tech support.

Tapered bottles.

Many wine bottles have a slight taper to them. Using the normal procedures outlined in the manual will cause the labels to be applied crooked. You may be able to apply your label straight if you angle the container idler roller to correspond with the angle of the taper. For example, if you normally apply labels to the bottle with both sides of the container idler roller in the third notch from the drive roller, try putting one side in notch three and the other side in notch four.

Motor stalling on labels 6" (15.3 cm) or wider.

For label stock 6" (15.3 cm) and wider, it may be necessary to reduce the speed of the Label Applicator. The AP360/362 includes a half-speed mode that generates more power from the motors for wider label stock. To activate this mode, hold down the Foot Switch while switching on the unit. The AP360/362 will revert back to the default mode when switched on without holding down the Foot Switch.

AP360/362 is running slow.

See Section 6.2. Make sure the foot switch is not depressed at any time during the boot up sequence.

Small diameter containers.

Small containers such as chap stick containers which are close to the edge of the minimum allowed diameter specification (0.6") will occasionally get pushed off the rollers by the oncoming label. To solve this problem add pressure to the arm by hand while applying labels on extremely small containers. This will prevent the label from pushing the container off the rollers.

There are bubbles or wrinkles in the label.

Wrinkles or bubbles can appear on the applied label if the container is not completely round, is not smooth or has bumps or ridges. To minimize bubbling or wrinkling with such bottles smooth the labels by hand as the container rotates around. For this procedure you must apply labels without using the container pressure arm.

Maintenance

Label edges fold over or catch on the sensor as they are applied to the container.

1. Over time adhesive from the labels can build up on the sensor flag just above the container rollers. Periodically clean the top of the sensor with a Q-tip and alcohol.
2. Make sure the sensor is positioned in the middle of the the label.

Unclamp Liner Idler Roller.

When not in use, leave the Liner Idler Roller in the unclamped position. This will minimize the possibility that permanent indentations will be made in the Liner Drive Roller.

Lubricate bearings.

Primera recommends oiling the four bearings associated with the Liner Drive Roller and Liner Idler Roller. Oil these four bearings for every 50,000 containers labeled. They should only be oiled after the first 50,000 containers as they are lubricated with a special grease at the factory. One drop of any machine oil or motor oil for each bearing should be adequate. This maintenance is optional but will increase the life of the applicators for heavy users who use the applicator for several hours each day.

Clean Label Gap Sensor Flag

Over time adhesive from the labels can build up on the sensor flag just above the container rollers. Periodically clean the top of the sensor with a Q-tip and alcohol.

Section 7: Specifications

Container width:	1.0" to 9.4" (25.4mm to 238.8mm)
Container diameter:	0.6" to 6.7" (15.2mm to 170.2mm)
Container shape:	Cylindrical and many tapered
Supply roll diameter:	Up to 8" (203mm)
Media liner width:	1.00" to 8.38" (25.4mm to 213.0mm)
Supply roll core:	2" to 3" ID (51.8mm to 76.2mm)
Electrical rating:	12 VDC, 5.0A
Power requirements:	100-240 VAC, 50/60 Hz, 60 watts
Feed speed:	4.0 in/sec. in Default Mode. 2.0 in/sec in Half-Speed mode for 6-8" wide label See Section 4A, Step 2 for details.
Agency certifications:	UL, UL-C, CE, FCC Class B
Weight:	16 lb (7.3 kg)
Dimensions:	13.4"W x 8.9"H x 12.9"D (340mm W x 226mm H x 328mm D)
Label width:	0.75" to 8.25" (19.1mm to 209.6mm)
Label height/length:	0.75" to 24.00" (19.1mm to 609.6mm)

