

**NOKIA
2220**

**NOKIA
2260**



User Guide

User Guide for Nokia 2220/2260 Phone

What information is needed?	Numbers	Where is the number?
My number		Wireless service provider
Voice mail number		Wireless service provider
Wireless provider's number		Wireless service provider
Provider's customer care		Wireless service provider
Model number	2220 2260	Label on back of phone (under battery).
Phone type	RH-40 (for 2220) RH-39 (for 2260)	Back of title page.
Electronic serial number (ESN)		Label on back of phone (under battery). See "Find your phone's label" on page 14.

The wireless phone described in this guide is approved for use in the TDMA and AMPS networks.

LEGAL INFORMATION

Part No. 9356128, Issue No. 1

Copyright © 2003 Nokia. All rights reserved.

Nokia, Nokia Connecting People, the Nokia Original Enhancements logos, Nokia 2220, Nokia 2260, Xpress-on, Pairs II, Space Impact and Snake II are trademarks or registered trademarks of Nokia. All other product and company names mentioned herein may be trademarks or tradenames of their respective owners.

Printed in Canada 05/2003

US Patent No 5818437 and other pending patents.

T9 text input software Copyright ©1999-2003. Tegic Communications, Inc. All rights reserved.



Includes RSA BSAFE cryptographic or security protocol software from RSA Security.

The information contained in this user guide was written for the Nokia 2220(RH-40) phone and the Nokia 2260(RH-39) phone. Nokia operates a policy of continuous development. Nokia reserves the right to make changes and improvements to any of the products described in this document without prior notice.

UNDER NO CIRCUMSTANCES SHALL NOKIA BE RESPONSIBLE FOR ANY LOSS OF DATA OR INCOME OR ANY SPECIAL, INCIDENTAL, AND CONSEQUENTIAL OR INDIRECT DAMAGES HOWSOEVER CAUSED.

THE CONTENTS OF THIS DOCUMENT ARE PROVIDED "AS IS." EXCEPT AS REQUIRED BY APPLICABLE LAW, NO WARRANTIES OF ANY KIND, EITHER EXPRESS OR IMPLIED, INCLUDING, BUT NOT LIMITED TO, THE IMPLIED WARRANTIES OF MERCHANTABILITY AND FITNESS FOR A PARTICULAR PURPOSE, ARE MADE IN RELATION TO THE ACCURACY AND RELIABILITY OR CONTENTS OF THIS DOCUMENT. NOKIA RESERVES THE RIGHT TO REVISE THIS DOCUMENT OR WITHDRAW IT AT ANY TIME WITHOUT PRIOR NOTICE.

EXPORT CONTROLS

This product contains commodities, technology or software exported from the United States in accordance with the Export Administration regulations. Diversion contrary to U.S. or Canadian law is prohibited.

FCC/INDUSTRY CANADA NOTICE

Your phone may cause TV or radio interference (for example, when using a telephone in close proximity to receiving equipment). The FCC or Industry Canada can require you to stop using your telephone if such interference cannot be eliminated. If you require assistance, contact your local service facility. This device complies with part 15 of the FCC rules. Operation is subject to the condition that this device does not cause harmful interference.

Contents

1	For your safety	1
2	Welcome and quick guide	5
	Get the most out of this guide	5
	Get started with the quick guide	7
	Understand wireless network services	9
	The antenna	9
	The battery	10
	Set up your headset	13
	Get help	14
3	Basic operations	17
	Switch your phone on or off	17
	Make and answer calls	17
	Check the start screen	19
	Check in-phone help	20
	Browse phone menus	21
	Contact list menu	24
4	Text entry	25
	Standard text entry	25
	Spaces, punctuation, and special characters entry	26
	Predictive text	27
5	Contact list	30
	Use contact list menus	30
	Save names, numbers, and e-mail addresses	30
	Recall names and numbers	31
	Edit a name or number	32
	Delete names and numbers	32
	Customize your contacts view	33
	Check memory status	33

6	Call log	34
	Call log options	34
	Check missed calls	35
	Check received calls	35
	Check dialed calls	35
	Use call timers	36
7	Messages	37
	Voice mail	37
	Text, e-mail, and picture messages	38
	Text messages	40
	Picture messages	43
	E-mail messages	44
8	Personalization	46
	Profiles	46
9	Advanced calling features	53
	Understand active-call options	53
	Use voice privacy	55
	Use call forwarding	56
	Use call waiting	57
	Use send own caller ID	58
	Select a phone number	58
	Use automatic redial	59
	Use 1-touch dialing	59
	Set touch tone strings	60
	Link contact list entries	62
	Select a system	63
10	Security	65
	Use Keyguard	65
	Understand the security code	66
	Restrict calls	66

11 Special features	68
Use the alarm clock	68
Use the calculator	69
Business cards	70
12 Games	72
Start a new game	72
Snake II	73
Space impact	73
Pairs II	73
13 Reference information	74
Battery statements	74
Proper care and maintenance	75
Important safety information	76
Make emergency calls	78
Certification Information(SAR)	79
Enhancement safety	80
Enhancements	81
Technical information	89
Troubleshooting	90
Nokia One-Year Limited Warranty	91
Index	94

NOTES

1 For your safety

The use of mobile phones and their accessories may be prohibited or restricted in certain areas. Obey applicable law regarding mobile phone usage.

Read these simple guidelines. Breaking the rules may be dangerous or illegal. Further detailed information is given in this manual.



Do not switch on the phone when wireless phone use is prohibited or when it may cause interference or danger.



ROAD SAFETY COMES FIRST

Don't use a hand-held phone while driving.



INTERFERENCE

All wireless phones may get interference, which could affect performance.



SWITCH OFF IN HOSPITALS

Follow any regulations or rules. Switch the phone off near medical equipment.



SWITCH OFF IN AIRCRAFT

Wireless devices can cause interference in aircraft.



SWITCH OFF WHEN REFUELING

Don't use the phone at a refueling point. Don't use near fuel or chemicals.



SWITCH OFF NEAR BLASTING

Don't use the phone where blasting is in progress. Observe restrictions, and follow any regulations or rules.



USE SENSIBLY

Use only in the normal position. Don't touch the antenna unnecessarily.



QUALIFIED SERVICE

Only qualified personnel may install or repair phone equipment.



ENHANCEMENTS AND BATTERIES

Use only approved enhancements and batteries. Do not connect incompatible products.



WATER-RESISTANCE

Your wireless phone is not water-resistant. Keep it dry.



CALLING

Ensure the phone is switched on and in service. Enter the phone number, including the area code, then press the **Talk** key. To end a call, press the **End** key. To answer a call, press the **Talk** key.



EMERGENCY CALLS

Ensure the phone is switched on and in service. Press the **End** key as many times as needed (for example, to exit a call, to exit a menu) to clear the display. Enter the emergency number, then press the **Talk** key. Give your location. Do not end the call until told to do so.

NOTES

Nokia 2220/2260 phone at a glance

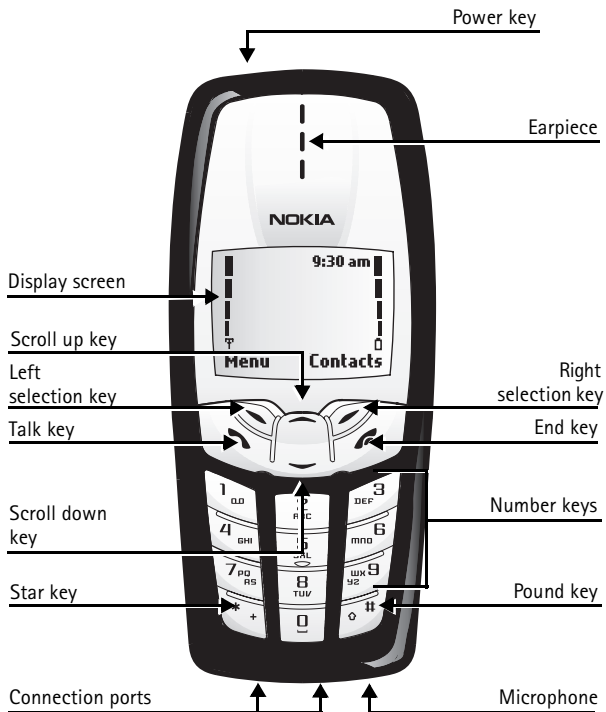

2 Welcome and quick guide

Congratulations on your purchase of a Nokia mobile phone, a new tool for the mobile information society.

• GET THE MOST OUT OF THIS GUIDE

The diagram to the left illustrates the various components of your phone. Familiarize yourself with the diagram to help you better understand the instructions that follow.

Understand the terms

This guide uses certain terms for the steps that you are asked to perform.

- **Press** means to briefly press, then release a key. For example, **press 7** means press the key on the keypad that is labeled with the number 7 and the letters, "p,q,r,s."
- **Press and hold** means to press and hold a key for two to three seconds (depending on the feature being used), then release the key.
- **Highlighted** options on the screen are enclosed within a dark bar. The selection keys are used to act on the highlighted option.
- **Selection keys** are used to select a menu option, press the selection key below the menu item on the phone's screen. In the example to the right, to select **Menu**, you would press the left selection key. To access the contact list, press **Contacts** (the right selection key).
- **Scroll keys** are used to move up and down in the menus. For example, if instructed to scroll to another contact list entry, this means to press the **Scroll up** or **Scroll down** key.
- The **Talk** key is used to place a call or to answer an incoming call.
- The **End** key is used to end a call or press and hold to return to the idle screen.

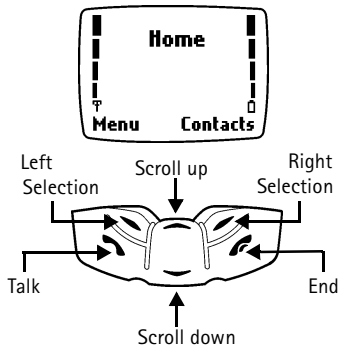

Notice text clues

This user guide provides text clues to make instructions clear and easy to follow.

Clue	What it means
bold	Indicates one of the following items: <ul style="list-style-type: none">• The word or phrase appears on the phone's screen.• Special text, such as Notes and Warnings.• The name of one of the phone keys.
<i>italic</i>	Italics indicate emphasis. Pay close attention to any information in italics.

Follow graphic clues

This guide uses icons (graphic clues) to alert you to important information.



Tip: Information about a shortcut or an alternate method of doing something.



Note: Explanation about a feature or an important concept.



Important: Critical information about a feature.



Caution: Help to avoid information loss.



Warning: Help to avoid personal injury, damage to the phone, or property damage.

Look for updates

From time to time, Nokia updates this user guide to reflect changes or corrections. The latest version may be available at www.nokia.ca.

• GET STARTED WITH THE QUICK GUIDE

Make a call	Enter phone number, press the Talk key.
Answer a call	Press the Talk key or Answer .
Answer with call waiting	Press the Talk key.
End a call	Press the End key.
Silence a call	Press the End key.
Redial	Press the Talk key twice.
Adjust call volume	During a call, press the Scroll up key to increase the volume or the Scroll down key to decrease the volume.
Use the in-call menu	In a call, press Options .
Use 1-touch dialing	Press and hold one of keys 2-9.
Save a name and number	Enter a number, press Save , enter a name, and press OK .
Retrieve a name/number	Press Contacts , select Find .
Retrieve a name/number during a call	Press Options , scroll to New call , press Select , press Find , enter first letter of the name.
Check voice mail	Press and hold 1 or call your voice mailbox number.
Send a text message	Press Menu 1-1 . Write the message. Press Options (Send will be the first option), press Select , enter the recipient's number, then press Send .
Send a business card	Retrieve a name from the contact list, press Options , select Send bus. card , enter the recipient's number, then press Send .



- Send an e-mail message** Press **Menu 1-2**. Enter the recipient's address, press **OK**, enter the subject, press **OK**, write the message, press **Options**, scroll to **Send**, then press **Select**. (You may need to enter the gateway number your service provider gave you.)
- Read new message** Press **Read**. If you have more than one message, scroll to the one you want, then press **Read** again.
- Reply to a message** Press **Options**, scroll to **Reply**, then press **Select**.
- Reply to an E-mail message** When reading the message, press **Options**, scroll to **Reply**, then press **Select**.



• UNDERSTAND WIRELESS NETWORK SERVICES

The wireless phone described in this guide is approved for use on the TDMA and AMPS networks. A number of features included in this guide are called Network Services. These are special services you arrange through your wireless service provider. Before you can take advantage of any of these Network Services, you must subscribe to them through your service provider and obtain instructions for their use from your service provider.



Note: Some networks may not support all language-dependent characters and/or services.

Network services for your Nokia phone include:

- Voice mail and voice privacy
- Call waiting, call forwarding, and caller ID
- Text, e-mail, and picture messages
- Ability to send your own number

Sign up with a service provider

Before you can use any network services, you must sign up with a wireless service provider. Your service provider will supply descriptions of special features and instructions for using their services.

• THE ANTENNA



Tip: Your phone has a built-in antenna. As with any other radio transmitting device, do **not** touch the antenna unnecessarily when the phone is switched on.



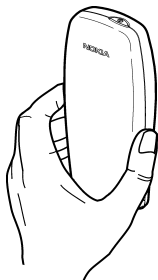

Contact with the antenna affects call quality and may cause the phone to operate at a higher power level than otherwise needed.

Not touching the antenna area during a phone call optimizes the antenna performance and the talk-time of your phone. Normal position: Hold the phone as you would any other telephone with the antenna pointed up and over your shoulder.

• THE BATTERY

This section tells you how to install and remove the battery. You will need to remove the battery when replacing it, or to view the phone's label (located under the battery). For important safety information on using batteries and chargers, see "Enhancement safety" on page 80.

Install the battery

- 1 Place the battery in the compartment with the label side facing up and the golden contact area of the battery aligned with the contact prongs inside the phone.
- 2 Press down on the battery until it snaps into place.

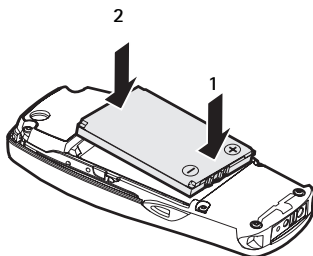

- 3 Align the cover over the back of the phone, placing the end of the cover approximately 5 mm (1/4) inch past the end of the phone. Lower the back cover onto the phone.

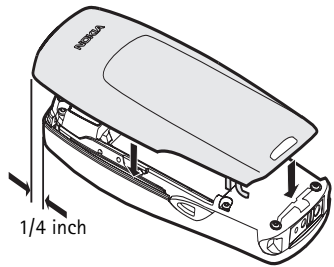

- 4 Press down slightly and slide the cover until it locks into place.

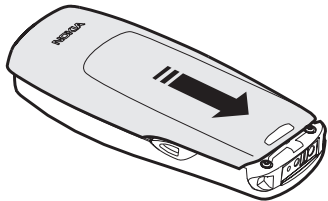

Remove the battery

If you purchase a new battery or need to access information on the phone's label, you may need to remove the battery. Make sure the phone has been turned off for at least 10 seconds.



Important: Dispose of batteries according to applicable local regulations (for example, recycling). Do not dispose as household waste.

- 1 Hold the phone with the back facing you. Apply pressure with your thumb on the lock button near the bottom of the phone.
- 2 Place the thumb of your other hand in the groove, approximately 2 -1/2 cm (1 inch) from the top of the phone. Apply pressure with the thumb, slide the back cover away from you to release it, then remove it.

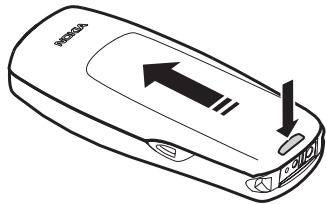

- 3 Look for the battery latch that runs along the end of the battery nearest the top of the phone.
- 4 Place your thumbs on the corners of the latch and press away from the battery.
- 5 Once the battery is released from the latch, it will lift slightly so that it can be removed from the phone.

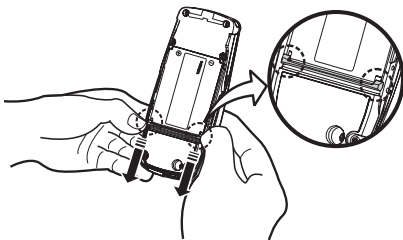

Warning: Use only your hands to remove the battery. Do not use any objects that may damage the phone or the battery.

Charge the battery

Before you begin using your phone, you need to prepare your phone by charging the battery.

- 1 Plug the charger into a standard wall outlet, then connect the lead from the charger to the bottom of the phone.
- 2 The battery power indicator (or battery bar) appears on the screen and starts scrolling. **Charging** appears if the phone is on.
- 3 When the battery bar stops scrolling, the battery charge is complete. **Battery full** appears if the phone is on.
- 4 Disconnect the charger from the phone.

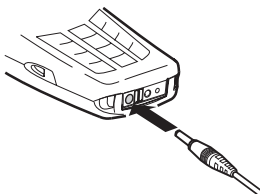

IMPORTANT BATTERY INFORMATION

Use the following guidelines to obtain the best performance from your battery:

- With your phone turned off, charge your new battery for four hours before its first use. Use the battery until it is fully discharged. Repeat this procedure twice for a total of three charging cycles.
- Battery operation time may be less than the estimated times during the first charges. This condition is normal.
- If the battery is fully discharged, the scrolling bars may not appear immediately when charging.
- After the first charge, you can make and receive calls during the charging cycle, but the calls interrupt the charge. When the phone call ends, the charge will resume.

- The bars on the screen stop scrolling and remain constant when the phone is charged. If you leave the phone connected to the charger, the battery receives an additional charge.



Note: The battery will accept a "trickle charge" for an additional two hours. See "Reference information" on page 74 for more information on batteries.

- Charging time depends on the charger and battery used. See "Batteries" on page 80 for charging, talk, and standby times.

PROLONG BATTERY LIFE

For good operation times with NiMH batteries, discharge the battery from time to time by leaving your phone switched on until it turns itself off. Ignore any messages to recharge your battery and let the battery completely discharge.



Important: Do not attempt to discharge the battery by any other means.

• SET UP YOUR HEADSET

Your phone is compatible with the HDC-5, HDC-10, HDE-2, and HDB-5 headsets. The headset provides convenient, hands-free use of the phone.

Connect the headset

- 1 Plug the headset plug into the bottom of your phone.
- 2 Put the round ear plug into one ear.

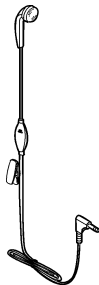

Use the headset

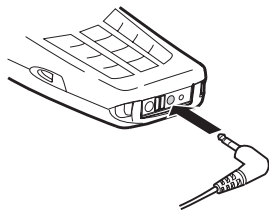

With the headset connected, you can make and answer calls as usual.

The microphone for the headset hangs at the side of your head. Although the microphone may seem far from your mouth, you can speak at a normal volume.



Note: You can set your phone to answer automatically when the headset is connected. See "Automatic answer" on page 50 for more information.

• GET HELP

Find your phone's label

When you call Nokia Customer Care or your service provider, you will need to provide specific information about your phone. This information is recorded on the phone's type label. The type label is located under the battery inside the phone's back cover. It contains the model and serial numbers as well as other important information about your phone. Please do not remove or deface the label.

Contact Nokia

If you have a question and have already checked the Troubleshooting section (see page 90), we recommend that you have the following information available before contacting Nokia Customer Care or your service provider:

- Your phone's model number
 - Nokia 2220 phone (single band)
 - Nokia 2260 phone (dual band)
- ESN (Electronic serial number – located on the label under the battery)
- Your billing address postal code
- The phone or accessory in question

Customer Care, Canada

Nokia Products Ltd.
601 Westney Road South
Ajax, Ontario L1S 4N7

Tel: 1-905-427-1373
1-888-22-NOKIA
(1-888-226-6542)

Fax: 1-905-427-1070

Web site: www.nokia.ca

Contact your service provider

You may want to save your service provider's customer support telephone number into your phone. This will let you easily contact your provider if you have questions or issues with your phone service.

Receive accessibility information

Nokia is committed to making mobile phones easy to use for all individuals, including those with disabilities. Nokia maintains an internet site that is dedicated to accessibility solutions. For more information about phone features, accessories and other Nokia products designed with your needs in mind, visit the web site at:

www.nokia.ca

LPS-3 MOBILE INDUCTIVE LOOPSET

The LPS-3 Loopset is a Nokia accessory designed to make the phone more accessible to hearing-aid users. The loopset gives hearing-aid users clear access to digital telephony for the first time. It allows people with T-coil equipped hearing aids to make and receive calls without noise interference.

To activate the Loopset, see "Accessory settings" on page 49.



Note: The loopset is sold separately as an enhancement to the phone.

HOW THE LOOPSET WORKS

The LPS-3 Loopset uses inductive technology to transmit sound to a hearing aid equipped with a T-coil. The sound from the phone is amplified more efficiently and background noise is eliminated.

The loopset is easy to use. Wear the loopset around your neck, connect it to your phone, and speak directly toward the microphone. For detailed instructions on using the loopset, refer to the booklet that comes with the LPS-3.

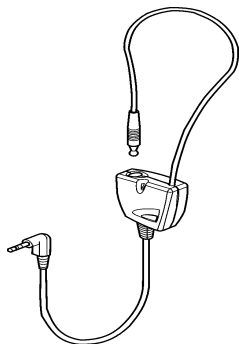

Set up the TTY/TDD profile

You can connect your phone to a TTY/TDD using the Nokia TTY/TDD Adapter (HDA-9). In order for your phone to recognize the TTY/TDD, you will need to connect the adapter to your phone.



Important: Some manufacturers of TTY/TDD devices suggest that the phone be at least 45.72 cm (18 inches) from the TTY/TDD device. When connecting to any other device, read its user guide or contact its manufacturer for detailed instructions and safety information.

- 1 Connect the TTY/TDD with a cable to the HDA-9 adapter.

- 2 Plug the HDA-9 adapter into the connector on the bottom of your phone, as shown in the illustration.

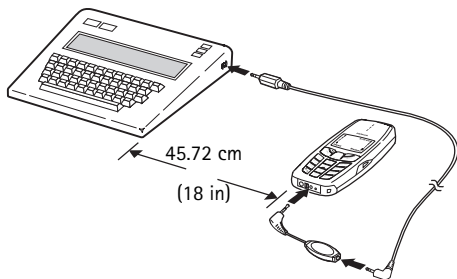

- 3 Press **Menu 4-4-4-1** (**Settings > Accessory settings > TTY/TDD > Use TTY**).
- 4 Scroll to **Yes**, then press **Select**.

NOTES ABOUT TTY/TDD CALLS

- The Nokia TTY/TDD Adapter (HDA-9) is for use with compatible TTY/TDD devices only. Check with the manufacturer of the TTY/TDD device to ensure that the connection is compatible.
- Check with the manufacturer of the TTY/TDD device for the appropriate connecting cable.
- TTY/TDD communications depend on network availability. Check with your service provider for availability and description of services.

MAKE A TTY/TDD CALL



Tip: Before making a TTY/TDD call with your phone, check the signal strength. See "Understand indicators and icons" on page 19 for details.

- 1 From the start screen, enter the number, and press the **Talk** key.
- 2 When the receiving party answers, begin typing your conversation on the TTY/TDD.

RECEIVE A TTY/TDD CALL

- 1 Make sure the TTY/TDD device is connected to your phone.
- 2 Press the **Talk** key to answer the call, then type your response on the TTY/TDD.

END A TTY/TDD CALL

Press the **End** key.

3 Basic operations

This section gives a brief introduction to the phone and shows quick steps for:

- Making and answering calls
- Adjusting the earpiece volume
- Navigating through menus
- Using menu shortcuts

You will also find information about the phone's icons and how to use in-phone help. The rest of this guide provides complete details on phone use.

• SWITCH YOUR PHONE ON OR OFF



Warning: Do not switch on the phone when wireless phone use is prohibited or when it may cause interference or danger.

To switch on your phone, press and hold the power key for 2 seconds.

To switch off your phone.

- Press and hold the power key.

OR

- Press the power key quickly. When **Switch off!** is highlighted on the screen, press **Select**.

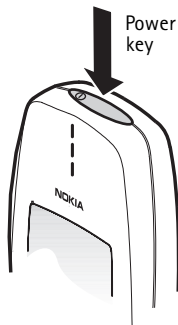

• MAKE AND ANSWER CALLS

There are several ways to make and answer calls on your phone. Once learning about the basic methods, you will discover other tips throughout this guide when reading about the phone's features.

Use the keypad

- 1 Enter the phone number, including the area code if needed.
- 2 Press the **Talk** key.



Important: Do not touch the antenna when the phone is switched on. Contact with the antenna affects call quality and may cause the phone to operate at a higher power level than otherwise needed.



Use the contact list

- 1 From the start screen, press the **Scroll up** or **Scroll down** key and scroll to the number you want.
- 2 Press the **Talk** key to make the call.



Tip: To skip ahead quickly in the list, press the number key that has the first letter of the name. You may have to press the key more than once to get to the correct letter.

Make a 1-touch dial call

Press and hold the key assigned to the number you wish to call.

To learn how to store a number for use with 1-touch dialing see "Assign a key to 1-touch dialing" on page 60.

End a call

Press the **End** key to end the call or to cancel the call attempt.

Answer a call

When your phone rings, press the **Talk** key. You can press any key to answer a call except the power key, end key, or the scroll keys.



Note: If Keyguard is active, the keypad will unlock when you have an incoming call.

Silence an incoming call

Press the **End** key or **Silent** to mute the ringing of an incoming call.

Redial the last-dialed number

Press the **Talk** key twice.

Adjust the earpiece volume

Adjust the earpiece volume during a call by pressing the scroll keys located just below the screen.

- Press the **Scroll up** key to increase the volume.
- Press the **Scroll down** key to decrease the volume.

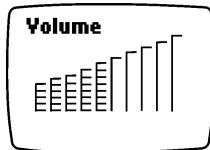

• CHECK THE START SCREEN

When you switch on your phone, a welcome appears, then you see the start screen.

The start screen appears when the phone is idling or standing by.

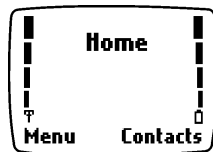

Start screen

Understand the Scroll Bar

When you press **Menu**, a vertical scroll bar appears on the right side of the screen. This scroll bar has a tab which moves up or down to indicate your location in the menu.

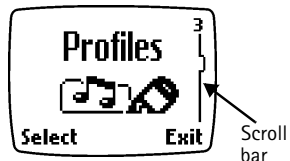

Scroll bar

Understand indicators and icons

You have two types of identifiers on your phone:

Indicators show the status of something. The phone uses three types of indicators: signal strength, battery power and handset volume.





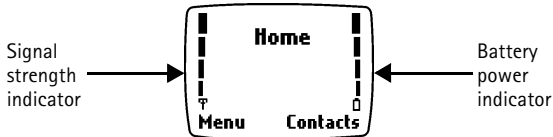





Icons are graphical representations of a specific item or situation. For example, an icon appears when you have a voice message in your mailbox.

Indicators



- Signal strength – shows the signal strength of the wireless network at your current location. The higher the bar, the stronger the signal.
- Battery power – shows the battery charge level. The higher the bar, the more power in the battery.
- Volume – shows the earpiece volume. See “Adjust the earpiece volume” on page 18.

Icons

Screen Icon	What it means
	Active call in progress.
	Silent has been selected as the current profile.
	The phone's keypad is locked to prevent any accidental key presses.
	One (or more) new voice messages waiting.
	One or more new text messages waiting. (If blinking, the text message memory is full.)
	Digital service is available.
	Standard text input mode for entering alpha characters. Press to switch between uppercase and lowercase input.
	Predictive text mode for quickly entering text messages. Press # to switch between uppercase and lowercase input.
	123 mode. This icon appears when you press and hold # while entering text. You can now enter only numbers (not alpha characters). Press and hold # again to return to text entry mode.
	Special character mode. This appears when you press * while entering text. Once the characters appear, you can select a special character by selecting Insert .
	Alarm clock is set.

• CHECK IN-PHONE HELP

Many menu items have brief help text. To view the help text, scroll to the menu item and wait for about 15 seconds. Press **More** or the **Scroll down** key to continue reading the text. Press **Back** to exit or wait a few seconds to return to the current menu.

• BROWSE PHONE MENUS

A menu is a list of choices you can make to change settings on your phone or use various phone features. Each menu can contain several levels of submenus. You can use menus and submenus two ways: by scrolling or by using a shortcut. This guide uses the shortcut method when describing how to use the phone's features.

Scroll through menus

- 1 At the start screen, press **Menu**, then scroll through the menus using the **Scroll up** and **Scroll down** keys.
- 2 Use the scroll and selection keys to navigate the submenus; press the **End** key to return to the start screen.

For example, when you see (**Profiles > Silent**) the scrolling method is: press **Menu**, scroll to **Profiles** and press **Select**, scroll to **Silent** and press **Options**.

Return to the previous menu level

You can return to the previous menu level by pressing the selection key labeled **Exit** or **Back**. Return to the start screen from any menu level by pressing the **End** key.

Use shortcuts

Menus and options are numbered so that you can quickly find your way to an option. The numbers appear in the top right corner of the screen and show your location in the menu.

- 1 Press **Menu**.
- 2 Within 3 seconds, enter the first number of the menu function you want to access.
- 3 Repeat until you have entered all the numbers.

For example, to select the **Silent profile**, press **Menu 3-2-1**.



MENU TIPS

- You can scroll upward to quickly access the last option in a menu list.
- You can return to the previous menu level by pressing **Back**.
- To exit a menu and return to the start screen, press the **End** key. If you leave a menu by pressing the **End** key, you cancel any changes you made.
- Some menus may not appear. Ask your service provider for details.

Menu shortcuts

1 MESSAGES



- 1 Write message 1-1
- 2 Write e-mail 1-2
- 3 Inbox 1-3
- 4 Outbox 1-4
- 5 Archive 1-5
- 6 Delete all 1-6
- 7 Picture messages 1-7
- 8 Voice messages 1-8
 - 1 Listen to voice messages 1-8-1
 - 2 Voice mailbox number .. 1-8-2

2 CALL LOG



- 1 Missed calls 2-1
- 2 Received calls 2-2
- 3 Dialed calls 2-3
- 4 Clear call lists 2-4
 - 1 All 2-4-1
 - 2 Missed 2-4-2
 - 3 Received 2-4-3
 - 4 Dialed 2-4-4
- 5 Call timers 2-5
 - 1 Duration of last call 2-5-1
 - 2 Duration of all calls 2-5-2
 - 3 Clear timers 2-5-3

3 PROFILES



- 1 Normal 3-1
 - 1 Select 3-1-1
 - 2 Customize 3-1-2
 - 1 Ringing options ... 3-1-2-1
 - 2 Ringing tone 3-1-2-2
 - 3 Ringing volume ... 3-1-2-3
 - 4 Vibrating alert ... 3-1-2-4
 - 5 Message alert tone 3-1-2-5
 - 6 Keypad tones 3-1-2-6
 - 7 Warning tones ... 3-1-2-7
 - 8 Profile name¹
- 2 Silent 3-2
 - 1 Select 3-2-1
 - 2 Customize 3-2-2
- 3 Meeting 3-3
 - 1 Select 3-3-1
 - 2 Customize 3-3-2
- 4 Outdoor 3-4
 - 1 Select 3-4-1
 - 2 Customize 3-4-2
- 5 Pager 3-5
 - 1 Select 3-5-1
 - 2 Customize 3-5-2

¹ The Profile name option is available for Silent, Meeting, Outdoor and Pager. The Normal profile cannot be renamed.

4 SETTINGS

- 1 Time settings 4-1
 - 1 Alarm clock 4-1-1
 - 1 On 4-1-1-1
 - 2 Off 4-1-1-2
 - 2 Clock 4-1-2
 - 1 Show/Hide clock. . 4-1-2-1
 - 2 Set the time 4-1-2-2
 - 3 Time format 4-1-2-3
 - 3 Auto-update of time... 4-1-3
- 2 Call settings 4-2
 - 1 Automatic redial 4-2-1
 - 2 Current call timer 4-2-2
- 3 Phone settings 4-3
 - 1 Language 4-3-1
 - 2 Touch tones 4-3-2
 - 1 Manual touch tones 4-3-2-1
 - 2 Touch tone length 4-3-2-2
 - 3 Welcome note 4-3-3
 - 4 Restore factory settings 4-3-4
- 4 Accessory settings¹ 4-4
 - 1 Headset 4-4-1
 - 2 Handsfree 4-4-2
 - 3 Loopset 4-4-3
 - 4 TTY/TDD 4-4-4
- 5 Security settings 4-5
 - 1 Call restrictions 4-5-1
 - 2 Change security code.. 4-5-2

1 The Accessory settings menu will not appear until after an accessory has been connected to the phone.

- 6 Network services 4-6
 - 1 Voice privacy 4-6-1
 - 2 Call forwarding² 4-6-2
 - 3 Call waiting² 4-6-3
 - 4 Send own caller ID²... 4-6-4
 - 5 Network feature setting 4-6-5
 - 6 Own number selection 4-6-6
 - 7 Public system selection. . 4-6-7
 - 8 Digital/analogue selection . 4-6-8

2 Call forwarding, call waiting and send own caller ID are network-dependent features. In some networks, the codes for these features must be activated and these sub menus will not appear until they are activated.

5 SYSTEM

- 1 Automatic 5-1
- 2 Manual 5-2
- 3 New search 5-3

6 GAMES

- 1 Snake II 6-1
- 2 Space Impact 6-2
- 3 Pairs II 6-3
- 4 Settings 6-4

7 CALCULATOR

Some features are network dependent and may not appear on your phone display.

• CONTACT LIST MENU

For access to the contact list and its menus:

- 1 Switch back to the start screen.
- 2 Press **Contacts**.

These options are available:

- 1 **Find**
- 2 **Add new**
- 3 **Delete all**
- 4 **Options**
 - 1 **Contacts view**
 - 2 **Memory status**
- 5 **1-touch dialing**

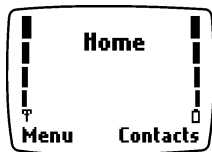

4 Text entry

There are two ways to enter letters and numbers into your phone:

- Standard text input - for making entries in the contact list.
- Predictive text input - for writing text messages, picture messages, and e-mails. For more detail, see "Predictive text" on page 27.

Current entry method

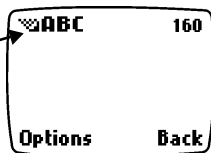

• STANDARD TEXT ENTRY

Standard text input is used when entering text into information prompts. You can use this method for all text entry, but predictive text input is the faster method for writing messages.

Enter letters (ABC mode)

When you add new names to the contact list, your phone automatically switches to the ABC mode and displays the ABC icon.

- 1 Find the key that has the letter you want to enter.
- 2 Press the key as many times as needed for the letter to appear on the screen.

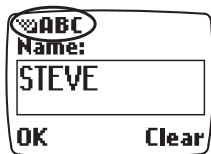

Enter numbers (123 mode)

To enter numbers:

- 1 Press and hold # to switch to 123 mode. Press the appropriate number key to enter a number.

OR

While in ABC mode, press and hold the corresponding number key until the number appears. If you make a mistake, press **Clear** to delete that character.



- 2 To return to the ABC mode, press and hold # again for two seconds.

DELETE MISTAKES

If you make a mistake, press **Clear** as needed to delete one or more characters. Press and hold **Clear** to delete the entire field of characters.

CHANGE FROM CAPITAL (UPPERCASE) LETTERS

To switch between capital (uppercase) and lowercase letters, press #.

The  icon in the upper left corner of the screen switches to , indicating that you can now enter lowercase letters. To switch back to uppercase letters again, press #.

• SPACES, PUNCTUATION, AND SPECIAL CHARACTERS ENTRY

Depending on the selected display language, the following characters may be available when entering characters from the keypad:

Key	Characters
1	. , ' ? ! @ ~ / " - 1
2	A B C 2
3	D E F 3
4	G H I 4
5	J K L 5
6	M N O 6
7	P Q R S 7

Key	Characters
8	T U V 8
9	W X Y Z 9
0	Enters an empty space or 0.
*	Special characters
#	Changes letter case; long press toggles between text input mode and number input mode.
Scroll up key	Moves cursor to the left of character.
Scroll down key	Moves cursor to the right of character.



Note: Some networks may not support all language-dependent characters and/or services.

- To enter a space, press 0 once.
- To enter punctuation, press 1 repeatedly until the character you want appears.

Use special characters

While entering text, press * (or press and hold *, if predictive text is on) to display special characters. Press * again to cycle through all characters:

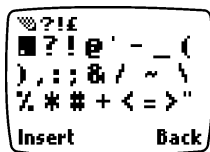

.	?	!	@	'	-	_	()
.	:	;	&	/	~	\	%	*
#	+	<	=	>	"	\$		

Use scroll keys to select the character you want, then press **Insert**.



Note: The order and availability of special characters may vary depending on your service provider.

Use four-way scrolling

Navigate special characters, using the 2, 4, 6, and 8 keys much as you would a joystick. Once a character is highlighted press 5 to insert the character into your message.

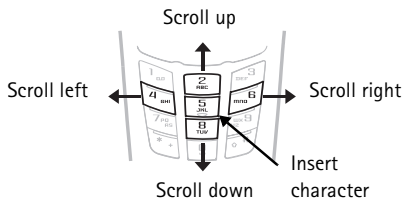

Use symbols in names and numbers

- To enter a symbol while adding a name to the contact list, press *.
- To add a special character for creating a number string in the number box, press *. See "Set touch tone strings" on page 60.

• PREDICTIVE TEXT

Predictive text input allows you to write messages much faster than the standard text method. With predictive text input, you only need to press each number key once for each letter. Your phone uses a built-in dictionary to predict or guess what you are writing. You can also add new words to the dictionary.

Turn on predictive text

- 1 Press **Menu**, then press **Select**.
- 2 Scroll to **Write message**, then press **Select**.
- 3 Press **Options**, scroll to **Predictive text**, then press **Select**.
- 4 Scroll to the language you want, then press **Select**.
T9 prediction on appears.

Enter predictive text

To write "Steve" with the English dictionary selected, press:

- 7 (for S) 8 (for t) 3 (for e) 8 (for v) 3 (for e)

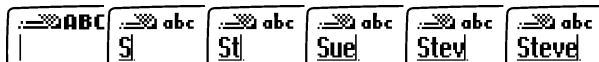

The display shows the above words for each key pressed.

Since the displayed word changes after each key stroke, disregard the word until you have keyed in all the characters. If the finished word is not the one you wanted, press * until your word appears. If it does not appear you will have an option to spell your word using standard text input.



Note: Predictive text input may not be available for all languages.

Turn off predictive text

- 1 While writing a text message, press **Options**.
- 2 Scroll to **Predictive text**, then press **Select**.
- 3 Scroll to **Prediction off**, then press **Select**.
T9 prediction off appears.

Save a word in the dictionary

If the word **Options** changes to **Spell**, the word you intended to write is not in the dictionary. You can add the word to predictive text.

Press **Spell**, enter the word using standard text entry and press **OK** to save the word. See "Standard text entry" on page 25 for more information.

Enter numbers

- 1 To add a number to the message, press and hold # until **123** appears on the screen.

- 2 Enter the numbers you want, then press and hold # to return to the **ABC mode**.



Note: You can also enter numbers from the **Options** menu (**Insert number**), or by a long press of the number key.

Enter punctuation and special characters

There are two ways to enter punctuation when using predictive text.

Press and hold * to access the special characters list. See “Use special characters” on page 27 for more information.

You can also enter symbols from the **Options** menu:

- 1 From the **Messages** screen, press **Options**.
- 2 Scroll to **Insert symbol** and press **Select**.
- 3 Scroll to the symbol you want and press **Insert**.

Change the case

Predictive text uses sentence case, but you can manually change between upper and lower case by pressing #.



Tip: You can switch between uppercase and lowercase standard text input and uppercase and lowercase predictive text input by repeatedly pressing #.

Write compound words

- 1 Write the first part of the word and press the **Scroll down** key to accept it.
- 2 Write the last part of the word and press **OK** or **0** to enter the word and a space.

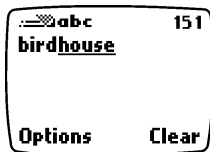

Clear the screen

To clear the text screen, press and hold **Clear**. You can also use the **Options** menu by selecting the **Clear text** option.

Delete information

To delete information when using predictive text, press **Clear**. Press and hold the clear key to delete text more quickly.

5 Contact list

Your phone includes a contact list that can store up to 200 entries (names and associated phone numbers). In addition, the contact list can store an e-mail address for a name.

- An entry in the contact list can consist of a number only or a name and a number.
- You cannot enter the same name twice. If you try to save a name that is already in the contact list, the phone asks if you want to replace the existing name.

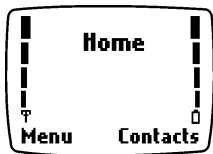

• USE CONTACT LIST MENUS

The contact list has several menus from which you can choose. These menus appear when you press **Contacts**. Use the scroll keys to move to the menu you want to use.

Menu	Function
Find	Allows you to search for a specific entry.
Add new	Allows you to add a new contact to your contact list.
Delete all	Allows you to delete names and numbers one by one or all at once.
Options	Takes you to a new menu list which includes the contact list's memory status and scrolling view.
1-touch dialing	Allows you to assign up to eight keys for speed dialing.

• SAVE NAMES, NUMBERS, AND E-MAIL ADDRESSES

For information on entering text, see "Standard text entry" on page 25.

Quickly save a name and number

This method is called quick save.

- 1 Enter the phone number using the keypad, then press **Save**.
- 2 Enter a name and press **OK**.

Save an entry using the contact list menu

- 1 Press **Contacts** to enter the contact list.
- 2 Scroll to **Add new**, then press **Select**.
- 3 Enter a name, then press **OK**.
- 4 Enter a number, then press **OK**.

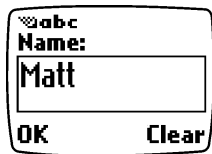

Save an e-mail address

Once you have added a contact to your contact list, you can add an e-mail address to that contact.



Note: E-mail addresses can only be added to existing contacts. For example, you cannot enter an e-mail address until you have selected a name or number.

- 1 Find the name to which you want to add an e-mail address.
- 2 Press **Details**, then press **Options**.



Important: If you have selected the **Name+number** contacts view, you will not need to press **Details**.

- 3 Scroll to **E-mail address**, then press **Select**.
- 4 Enter the e-mail address, and press **OK**.

• RECALL NAMES AND NUMBERS

- 1 At the start screen, press **Contacts**.
- 2 Select **Find**, then enter one or two letters of the name you want to recall.
- 3 Press **Find**, then press the **Talk** key to dial the number.

You may have to scroll to the appropriate entry in a list if you have stored names that are similar to each other.

Recall information with shortcuts

You may want to use some of these shortcuts or alternate methods for recalling a number.

- Press **Contacts**, enter the first letter of the name, scroll to the name, and press the **Talk** key to dial the number.
- At the start screen, press the scroll keys to enter your list of names, scroll to the name you want to dial, and press the **Talk** key.
- Press the **Talk** key to access a list of your last ten dialed calls, scroll to the one you want to dial, then press the **Talk** key again.

• EDIT A NAME OR NUMBER

You can edit a name, a number, or both.

- 1 Recall the name or number you want to edit.
- 2 Press **Details**, then press **Options**.



Important: If you have selected the **Name+number** contacts view, you do not need to press **Details**.

- 3 **Edit appears**, then press **Select**.
- 4 Edit the name or number and press **OK**.

• DELETE NAMES AND NUMBERS

Erasing stored names and numbers removes them from your phone. Once you delete an item, you can restore it only by re-entering it.

Individual entries

- 1 Recall the contact list entry you want to delete.
- 2 Press **Details**, then press **Options**.



Important: If you have selected the **Name+number** contacts view, you do not need to press **Details**.

- 3 Scroll to **Delete**, and press **Select**.

The message **Delete?** appears.

- 4 Press **OK**.

Entire contents

- 1 Press **Contacts**, scroll to **Delete all**, and press **Select**.
- 2 Scroll to **Delete all** and press **Select**.
- 3 When you see the message **Are you sure?**, press **OK**.
- 4 Enter your security code and press **OK**.



Note: For information on your security code, see "Understand the security code" on page 66.

• CUSTOMIZE YOUR CONTACTS VIEW

You can change how the information in your contact list looks on your screen. There are three different ways to view your contact list. In all views, you can use the scroll keys to move up and down through the list of names.

Choice	What it does
Name list	Displays three names on the screen at a time.
Name+number	Only one name and its corresponding number appears on the screen at a time.
Name only	Displays individual names only. You can view the corresponding phone number by pressing Details and then scrolling up or down.

Select your scrolling view

To change the way you view names and numbers in your contact list.

- 1 Press **Contacts**, scroll to **Options**, and press **Select**.
- 2 At **Contacts view**, press **Select**.
- 3 Scroll to the view you want and press **Select**.



Important: If you have selected the **Name+number** contacts view, you will not need to press **Details** when working with contact list options.

• CHECK MEMORY STATUS

You can check how much contact list memory is free and how much has been used.

- 1 Press **Contacts** and scroll to **Options**.
- 2 Press **Select**, scroll to **Memory status**, and press **Select**.

6 Call log

Your phone provides a call log that registers information about calls you make and receive. The call log keeps track of the following:

- Missed calls
- Received calls
- Dialed calls

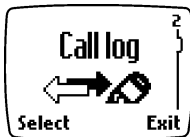

 **Note:** This function only works in digital networks and only when caller ID is enabled.

• CALL LOG OPTIONS

When you view the missed calls, received calls, or dialed calls list, and press **Options**, the following choices may appear.

 **Note:** Not all options will appear each time. Also, the order of options may vary.

Choice	What it does
Call time	Shows the time when the call was connected. (You must first set the phone's clock)
Send message	Allows you to write a short text message to the person who called you or to whom you called.
Edit number	Allows you to edit the displayed number and save it with a name to your contact list.
Save	Allows you to enter a name for the number and save both to your contact list.
Delete	Allows you to delete the number from the call list.
View number	Allows you to view the caller's phone number. In order to see this option, the caller's name and number must be stored in the contact list.
Call	Dials the number from the call log.

• CHECK MISSED CALLS

If you do not answer a call, the message **Missed calls** appears on your phone's screen, along with the number of calls missed. Your phone stores the last ten numbers associated with calls you have missed.

- 1 Press **Menu 2-1 (Call log > Missed calls)**.
The phone displays a list of the numbers of the calls you missed.
- 2 Press the **Scroll up** or **Scroll down** key to scroll through the list.
- 3 Press the **Talk** key if you want to dial the number.

• CHECK RECEIVED CALLS

Your phone stores the last ten numbers associated with calls that you have answered. To check this list of numbers:

- 1 Press **Menu 2-2 (Call log > Received calls)**.
- 2 Scroll through the list of received numbers and highlight your selection.
- 3 Press the **Talk** key if you want to dial the number.

• CHECK DIALED CALLS

Your phone stores the last ten numbers associated with calls that you have dialed. To check this list of numbers:

- 1 Press **Menu 2-3 (Call log > Dialed calls)**.
- 2 Scroll through the list of dialed numbers and highlight your selection.
- 3 Press the **Talk** key if you want to dial the number.

Clear call lists

Your phone uses call lists to track numbers for incoming, outgoing, and missed calls. You can delete some or all of the numbers that appear in the call log.



Caution: You cannot undo this operation.

- 1 Press **Menu 2-4 (Call log > Clear call lists)**.
- 2 Use the **Scroll up** or **Scroll down** key to scroll through the options list.
The list includes **All**, **Missed**, **Received**, and **Dialed**.
- 3 Stop at the appropriate option and press **Select**.
The **All** option clears every number in every list, whereas the other options clear only the numbers associated with that option. For example, the **Dialed** option clears only the numbers associated with calls you previously dialed.

• USE CALL TIMERS

Your phone tracks the amount of time you spend on each call. To obtain information about time spent on phone calls:

- 1 Press **Menu 2-5** (**Call log > Call timers**).
- 2 Scroll through the following options:

Option	What it does
Duration of last call	Shows the call duration of the last call.
Duration of all calls	Shows the call duration of all calls that have been made and received since you reset the timers.
Clear timers	Clears all call timers for the currently selected phone number. Your phone includes separate timers for each number used.



Note: The actual time invoiced for calls by your service provider may vary, depending upon network features, rounding-off for billing, and so forth.



Caution: If you select the **Clear timers** option, the action cannot be undone. If you use the call timers to log the amount of time spent on calls, you may want to record the call timer information before you clear it.

Clear call timers

- 1 Press **Menu 2-5-3** (**Call log > Call timers > Clear timers**).
- 2 Enter your security code and press **OK**.



Note: For information on your security code, see "Understand the security code" on page 66.

Turn on a current call timer

You can set your phone to show the running elapsed time while a call is active.

- 1 Press **Menu 4-2-2** (**Settings > Call settings > Current call timer**).
- 2 Scroll to **On** and press **Select**.

From this point on, the timer is active during each call you make or receive. The time appears on the phone's screen.

- 3 After a call has ended, press any key on the phone's keypad to clear the current call time from the screen.

7 Messages

Use mobile messages to keep in touch with friends, family and business associates. Your phone allows you to do the following:

- Voice mail
- Send and receive text messages
- Send and receive picture messages
- Communicate with e-mail

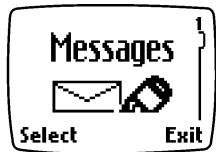

Not all messaging features are available in all wireless networks. Contact your service provider for availability and subscription information.

• VOICE MAIL

Voice mail provides a way for callers who miss you to leave a message that you can retrieve later.

Check for messages

Your phone beeps when you receive a voice message. Also, the message **New voice message** appears on your phone's screen, along with the  icon.

If you receive more than one voice mail message, your phone may show the number of messages that you have received. The wireless network provider determines the type of indication you will receive.



Note: To use voice mail, you need to learn the voice mail system's various greetings, passwords, and prompts. Your service provider can provide instructions.

Save the voice mailbox number

As part of your network's voice mail feature, your service provider gives you a voice mailbox phone number.

- 1 Press **Menu 1-8-2 (Messages > Voice messages > Voice mailbox number)**.
- 2 Enter your voice mailbox phone number, then press **OK**.

Your voice mailbox number can be up to 32 digits long and is used until you change it. Therefore, if your phone number changes, the voice mail number will probably change also. For further information, contact your service provider.

Listen to your voice messages

The way you listen to your voice messages depends on your service provider. Call your service provider if you have any questions.

- 1 When your phone alerts you to new voice messages, press **Listen** and follow the instructions given on the phone.
- 2 If you want to listen to your messages later, press **Exit**.
- 3 To listen to your voice messages:

Press and hold 1.

OR

Press **Menu 1-8-1 (Messages > Voice messages > Listen to voice messages)**.
Follow the prompts to review your messages.

• TEXT, E-MAIL, AND PICTURE MESSAGES

Your phone is capable of a variety of messaging services including text messages (SMS or Short Message Service), picture messages, and e-mail messages. Messaging services are Network Services. Consult your service provider for information on availability, subscribing to and using messaging services.

Understand messaging

Message recipients: The phone to which you send a message must support messages. The recipient may not receive the SMS message you send if the recipient's account is with a different service provider or uses a different protocol.

Message length: The maximum length of a sent or received message is 160 characters. Your phone has space for several messages, depending on the length of each message. The maximum length of a message also may depend on the capabilities of the network from which the message originated.

Options when working with messages

There are several options available when working with text, picture, and e-mail messages. The order and availability of options may vary depending on the messaging function and your service provider.

Option	Description
Send	Attempts to send the text message to the recipient.
Settings	Allows you to set Urgent , Read receipt , Reply req. , and Callback no. options for the message.
Save	Saves the message in the archive folder.
Clear text	Clears the text in the message editor.
Exit editor	Takes you back to the Write message menu.
Predictive text	Allows you to turn predictive text on and off.
Insert word	If predictive text (T9) is activated, you can manually spell a word and insert it into your message.
Insert number	Allows you to insert numbers into the message.
Insert symbol	Allows you to access the list of special characters.
Save picture	Allows you to save a picture to the template folder.
Matches	Lists alternative word choices while using predictive text.
Details	Available when viewing a picture message. This option allows you to view the name and number of the sender.
Preview	Previews your picture message before sending.
Edit text	Allows you to add text to a picture message.
Delete	Allows you to delete a message.
Forward	Allows you to forward a message.
Use number	Allows you to use the number associated with a message.
Replay	Allows you to replay messages you receive.
Edit recipient	Allows you to edit the e-mail address.
Edit subject	Allows you to edit the subject of an e-mail message.



Tip: When writing messages, you can switch between uppercase and lowercase standard text input and uppercase and lowercase predictive text input by repeatedly pressing #.

Organize messages using folders

Your phone has folders for managing text messages. Text message folders are located under the **Messages** menu.

THE INBOX FOLDER

The inbox stores messages you receive. Messages remain in the inbox until you delete them or save them in the archive folder. You can forward or reply to messages in your inbox.

THE OUTBOX FOLDER

The outbox stores messages you have written, sent, edited, and forwarded. Messages in the outbox are not saved messages. As you send new messages, old messages will automatically be removed from the outbox. When message memory is full, one or more messages of the lowest priority are automatically deleted from the outbox. If you want to save a message you have sent, read the message while it is in the outbox and use the options menu to save it to the archive folder.

THE ARCHIVE FOLDER

The archive folder stores messages you have saved. You can save messages to the archive folder from the inbox and the outbox. You can reply to or forward saved messages.

DELETE MESSAGES FROM FOLDERS

You can delete all messages located within a specific folder.

- 1 Press **Menu 1-6 (Messages > Delete all)**.
- 2 Scroll to one of the following options, then press **Select**.

All read

Inbox

Archive

Outbox

- 3 Enter your security code, then press **OK**.



Note: For information on your security code, see "Understand the security code" on page 66.

• TEXT MESSAGES

Use your phone to send and receive short text messages.

Write and send a text message

When writing text messages, use the predictive text method for faster text entry. For details, see "Predictive text" on page 27.

- 1 Press **Menu**, select **Messages**, then select **Write message**.
The message screen appears.
- 2 Enter a message of up to 160 characters.
A counter in the upper right corner of the screen shows the number of characters remaining.
- 3 When you have finished writing the message, press **Options**, scroll to **Send**, then press **Select**.
- 4 Enter or recall the recipient's phone number, then press **Send**.

Sending message appears.



Note: When sending messages via the SMS network service, your phone may display the words, **Message Sent**. This is an indication that the message has been sent by your phone to the message center number programmed into your phone. This is not an indication that the message has been received at the intended destination. For more details about SMS services, check with your service provider.

Read a text message

When you receive a text message, the phone beeps and displays **Message received** and the  indicator in the upper left corner of the screen.

- 1 Press **Read** to view the message.
- 2 Use the scroll keys to view the whole message, if necessary.
- 3 Once you have finished, press the **End** key to return to the start screen, or press **Options** for other choices, such as **Reply** or **Forward**.

When the phone displays **Message received**, pressing **Exit** moves the new message to the inbox and returns you to the start screen. To read the message later, press **Menu 1-3 (Messages > Inbox)**. If you have more than one new message, scroll to the message you want to view. Messages in the inbox are listed in the order they are received, with the most recent message listed first. Unread messages are indicated by .

Respond to a text message

There are many options available for working with text messages. For a list of options and their descriptions, see "Options when working with messages" on page 38.

REPLY TO THE MESSAGE

- 1 When reading the message, press **Options**.
- 2 Scroll to **Reply**, then press **Select**.
- 3 Choose to reply **As message** or **As e-mail**, then press **Select**.

When replying as e-mail, see "Send an e-mail message" on page 44. When replying as message, see "Write and send a text message" on page 41.

FORWARD THE MESSAGE

- 1 When reading the message, press **Options**.
- 2 Scroll to **Forward**, then press **Select**.
- 3 Choose to forward **As message** or **As e-mail**, then press **Select**.

When forwarding as e-mail, see "Send an e-mail message" on page 44. When forwarding as message, see "Write and send a text message" on page 41.

SAVE A MESSAGE

- 1 When reading the message, press **Options**.
- 2 Scroll to **Save**, then press **Select**.

The message will be moved to the archive folder.

DELETE A MESSAGE

- 1 When reading the message, press **Options**.
- 2 Scroll to **Delete**, then press **Select**.
Delete message? appears.
- 3 Press **OK**.

WHEN MEMORY IS FULL

When message memory is full, one or more messages of the lowest priority are automatically deleted. When you receive an emergency message, messages may be deleted from any of your message folders.

If you have more messages waiting at the network,  blinks on the start screen. You can delete old messages to create space for new messages.

• PICTURE MESSAGES

Your phone offers five picture messages that you can use to send pictures and text to your friends and family. You can also save a new picture by replacing an existing picture. For possible message options, see "Options when working with messages" on page 38.

Each picture message is made up of several text messages. Therefore, sending one picture message may cost more than sending one text message. Contact your service provider for pricing information.



Note: This function can be used only if it is supported by your network operator or service provider. Only phones that offer picture message features can receive and display picture messages.

Send a picture message

- 1 Press **Menu 1-7 (Messages > Picture Messages)**.
- 2 Scroll to the picture you want to send, then press **Show**.
The picture appears. To choose a different picture, press **Back** and scroll to another picture.
- 3 Press **Options**.
Edit text appears.
- 4 Press **Select**, then add a text message to send with the picture.
After you enter the text, you have several options. To view a list of possible options, see "Options when working with messages" on page 38.
- 5 To send the picture and message, press **Options**.
- 6 Scroll to **Send**, then press **Select**.
- 7 Enter or recall the recipient's phone number, then press **Send**.
Sending picture message appears.

PREVIEW A PICTURE MESSAGE BEFORE SENDING

After writing text for your picture message, you can preview the message before sending it.

- 1 Press **Options**.
- 2 Scroll to **Preview**, then press **Select**.
- 3 After viewing the message, press **Back**.

Receive a picture message

- 1 When your phone displays **Picture message received**, press **Show** and the message appears.
- 2 If the picture has a text message with it, scroll up or down to see the entire message.

Save a picture message

- 1 Press **Show** to view the message, then press **Save**.
You have the option to replace a current message.
- 2 Scroll to the picture you want to delete, then press **Replace**.

• E-MAIL MESSAGES

You can send e-mail up to 160 characters in length to anyone with an e-mail address. This is a Network Service.

- Messages sent to you by e-mail arrive as regular text messages. You can use all the options described earlier to save, reply to, or forward a message.
- Contact your service provider to get the e-mail address and gateway number for your phone, and for more information on using e-mail.

Send an e-mail message

- 1 Press **Menu 1-2 (Messages > Write e-mail)**.



Note: If you get a prompt asking you to enter your e-mail gateway number, you must obtain this number from your service provider.

- 2 At the prompt, enter your recipient's e-mail address or press **Find** to look through and select a saved e-mail address from your phone list.
- 3 Press **OK**.
- 4 At the prompt, enter a subject for your e-mail message. (You are not required to enter a subject.)
- 5 Press **OK** when you are finished.



Note: Predictive text is not available when entering an e-mail address or a subject line for your e-mail.

A screen will appear allowing you to enter the text of your message. Your total message, including the address and subject line, can be up to 160 characters. There is a running total of remaining characters in the top right corner of the screen.

- 6 After you finish entering the text of your e-mail, press **Options**, scroll to **Send**, then press **Select**.

Receive an e-mail message

When you receive an e-mail message, the phone makes a sound and displays **Message received** and the  indicator in the upper left corner of the screen.

To read the message, press **Read**.

When reading a received e-mail message, you can choose other options, such as **Reply** and **Forward**. See "Options when working with messages" on page 38.

Edit an existing e-mail message

Edit an e-mail message by replying to the message or forwarding it. You can edit messages from any folder.

Reply to an e-mail message

- 1 When reading the message, press **Options**.
- 2 Scroll to **Reply**, then press **Select**.
- 3 Choose to reply **As message** or **As e-mail**, then press **Select**.

When replying as e-mail, see "Send an e-mail message" on page 44. When replying as message, see "Write and send a text message" on page 41.

Forward an e-mail message

- 1 When reading the message, press **Options**.
- 2 Scroll to **Forward**, then press **Select**.
- 3 Choose to forward **As message** or **As e-mail**, then press **Select**.

When forwarding as e-mail, see "Send an e-mail message" on page 44. When forwarding as a message, see "Write and send a text message" on page 41.

8 Personalization

The Nokia 2200 series can be easily customized to fit your lifestyle. The display language, ringing tones, audio, and accessory settings (among others) can all be modified to suit your needs.

Your phone has various profiles which allow you to customize ringing and alert tones for different environments. Once you modify the profiles, you can activate the profile that is appropriate for your surroundings. For example, you can select the **Silent** profile while at the movies or the **Outdoor** profile when at a sporting event.

• PROFILES

Profiles let you set sound settings to match your environment, whether it is a meeting or a soccer game. Just pick the profile that suits your current environment: **Normal**, **Silent**, **Meeting**, **Outdoor** or **Pager**.

You can customize any of the profiles and set your own preferences for the following settings:

- Ringing options
- Ringing tone
- Ringing volume
- Message alert tone
- Vibrating alert
- Keypad tones
- Warning tones
- Profile name (except for the **Normal** profile)



Important: You can select a default profile for each of these accessories: **Headset**, **Handsfree**(Car Kit), and **Loopset**. To learn more about accessories, see "Accessory settings" on page 49.

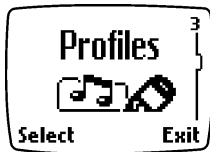

Select a profile

- 1 Quickly press and release the **Power** key.
- 2 Use the **Scroll up** or **Scroll down** key to move to the profile you want to use. Profile names are highlighted as you scroll through them.
- 3 Press **Select** to activate a profile.

Customize a profile

- 1 Press **Menu 3 (Profiles)**.
- 2 Scroll to the profile you want to customize, then press **Options**.
- 3 Scroll to **Customize**, then press **Select**.
- 4 Use the scroll keys to display each of the profile options. Once you find the option you would like to customize, press **Select**.

SET THE RINGING OPTIONS

You can choose the type of ring your phone uses to notify you of an incoming call. This setting does not affect any incoming text message alert tones.

- 1 Press **Menu 3 (Profiles)**.
Your phone lists each profile.
- 2 Scroll to the desired profile in the list for which you want to set the ringing options, and press **Options**.
- 3 Scroll to **Customize**, then press **Select**.
- 4 Scroll to **Ringing options** and press **Select**.
- 5 Scroll to one of the ringing options, as described below, and press **Select**.

Ring: The phone rings normally.

Ascending: Ringing volume increases (gets louder) if the phone is not answered.

Ring once: The phone rings once to indicate an incoming call.

Beep once: The phone beeps once to indicate an incoming call.

Silent: The phone makes no sound.

SET THE RINGING TONE

The ringing tone is the sound your phone makes when you receive a call. Your phone contains preprogrammed ringing tones. You can set the ringing tone to a specific sound or tune to personalize how the phone rings. You can also add custom ringing tones to your phone.

- 1 Press **Menu 3 (Profiles)**.
Your phone lists each profile.
- 2 Scroll to the profile for which you want to set the ringing tone, then press **Options**.
- 3 Scroll to **Customize**, then press **Select**.
- 4 Scroll to **Ringing tone** and press **Select**.

- 5 Scroll through the options when you hear the tone you want, press **Select**.



Note: If you have already chosen a ringing option of either **Silent** or **Beep once**, the ringing tones are already turned off. See "Set the ringing options" on page 47 for details. As you scroll through the ringing tones, you can listen to a sample of each if your current ringing option is not set to **Silent**.

SET THE RINGING VOLUME

Set the default ringing volume for incoming voice calls and message alert tones.

- 1 Press **Menu 3 (Profiles)**.
- 2 Scroll to the profile you will set and press **Options**.
- 3 Scroll to **Customize**, then press **Select**.
- 4 Scroll to **Ringing volume** and press **Select**.
- 5 Scroll through the options. When you hear the right volume level, press **Select**.

SET A VIBRATING ALERT

Set your phone to vibrate to indicate an incoming call.

- 1 Press **Menu 3 (Profiles)**.
- 2 Scroll to the profile for which you want to set the vibrating alert and press **Options**.
- 3 Scroll to **Customize**, then press **Select**.
- 4 Scroll to **Vibrating alert** and press **Select**.
- 5 Scroll to **On** and press **OK**.

The phone does not vibrate when it is connected to or placed in any charging device.

SET THE MESSAGE ALERT TONE

Set your phone to use a certain tone to indicate an incoming text message.

- 1 Press **Menu 3 (Profiles)**.
- 2 Scroll to the profile for which you want to set the message alert tone and press **Options**.
- 3 Scroll to **Customize**, then press **Select**.
- 4 Scroll to **Message alert tone**, then press **Select**.
- 5 Scroll through the tone selections.

The phone plays samples of each selection as you scroll to it.

- 6 When you find the tone you want, press **Select**.

SET KEYPAD TONES

Keypad tones set the volume of the tone you hear when you press phone keys.

- 1 Press **Menu 3 (Profiles)**.
- 2 Scroll to the profile for which you want to set the keypad tones and press **Options**.
- 3 Scroll to **Customize**, then press **Select**.
- 4 Scroll to **Keypad tones** and press **Select**.
- 5 Scroll to one of the levels and press **Select**.
 - If you choose **Off**, no keypad tones are heard.
 - If you chose the **Silent profile** in step 2, the keypad tones are turned off.

SET THE WARNING TONES

Warning tones include the sounds your phone makes during error conditions, during confirmations, when the battery is low, and when you need to recharge the battery.

- 1 Press **Menu 3 (Profiles)**.
- 2 Scroll to the profile for which you want to set the warning tones, then press **Options**.
- 3 Scroll to **Customize**, then press **Select**.
- 4 Scroll to **Warning tones**, then press **Select**.
- 5 Scroll to **On** or **Off** and press **Select**.

Rename a profile

- 1 Press **Menu 3 (Profiles)**.
- 2 Scroll to the desired profile, then press **Options**.
- 3 Scroll to **Customize**, then press **Select**.
- 4 Scroll to **Profile name**, then press **Select**.
- 5 Enter the new name and press **OK**.



Note: You cannot rename the **Normal** profile.

Accessory settings

Use your phone with these Nokia accessories:

- Headset (HDC-5, HDE-2, HDB-5, and HDC-10)
- Handsfree Car Kit (CARK-125, CARK-134 and PPH-1)

- Loopset (LPS-3)
- TTY/TDD Adapter (HDA-9)



Note: You can select a default profile that will be associated with each accessory, such as **Normal**. However, the **Accessory settings** menu will not appear until after an accessory has been connected to the phone at least once.

SET UP THE LOOPSET

When you want to use the loopset, you will have to activate the accessory setting.

- 1 Attach the loopset to the phone.
- 2 Press **Menu 4-4-3 (Settings > Accessory settings > Loopset)**.
- 3 Scroll to **Use loopset**, then press **Select**.
- 4 Scroll to **Yes**, then press **Select**.

AUTOMATIC ANSWER

This feature lets your phone answer incoming calls after just one ring when an accessory is connected to the phone.

- 1 Press **Menu 4-4 (Settings > Accessory settings)**.
- 2 Scroll to **Headset, Handsfree, or Loopset**, then press **Select**.
- 3 Scroll to **Automatic answer**, then press **Select**.
- 4 Scroll to **On** and press **Select**.

SET THE LIGHTS (CAR KIT ONLY)

When your phone is connected to a car kit, you have a choice of having the phone lights on (a) continuously or (b) only when you use it.

- 1 Press **Menu 4-4-2-3 (Settings > Accessory settings > Handsfree > Lights)**.
- 2 Choose one of the following options, then press **OK**:
 - On:** The lights will remain on while the phone is connected to the car kit.
 - Automatic:** The lights will be turned on only when the phone is being used.

SET THE DEFAULT PROFILE

When you use the headset, car kit or loopset, you have the option of selecting a default profile. You can use the currently selected profile (for example, **Normal**) or you can choose from the list.

- 1 Press **Menu 4-4 (Settings > Accessory settings)**.
- 2 Scroll to **Headset, Handsfree (Car Kit) or Loopset**, then press **Select**.

- 3 Scroll to **Default profile**, then press **Select**.
- 4 Scroll to the profile you want, then press **Select**.



Note: The **Active profile** uses the current profile setting you have selected for your phone.

Set the display language

You can choose your phone's display language.

- 1 Press **Menu 4-3-1** (**Settings > Phone settings > Language**).
- 2 Scroll to the language you want, then press **Select**.

Set the clock

Your phone contains a real-time clock that can be set two different ways: the clock can use the time information provided by the wireless system or it can be set manually. Once the time is set, you can display the clock on the start screen.

For added convenience, the clock is connected to an alarm clock. See "Use the alarm clock" on page 68 for additional information.

SELECT THE TIME FORMAT

You can choose whether your clock shows time in an am/pm format or a 24-hour format.

- 1 Press **Menu 4-1-2-3** (**Settings > Time settings > Clock > Time format**).
- 2 Scroll to **24-hour** or **am/pm** and press **Select**.

SET THE CLOCK USING AM/PM FORMAT

- 1 Press **Menu 4-1-2-2** (**Settings > Time settings > Clock > Set the time**).
- 2 Enter the time using an *hh:mm* format and press **OK**.

For example, to set your clock to 8:40, enter **08:40**.

- 3 Scroll to **am** or **pm** and press **Select**.



Note: Even if you have selected the **am/pm** format, you can still set the clock in the **24-hour** format.

SET THE CLOCK USING 24-HOUR FORMAT

- 1 Press **Menu 4-1-2-2** (**Settings > Time settings > Clock > Set the time**).
- 2 Enter the time using an *hh:mm* format and press **OK**.

For example, to set your clock to 8:40, enter **08:40** (for am) or **20:40** (for pm).

- 3 Press **OK**.

Automatic update of time

Set your phone to update the time from the network when you turn the phone on. If the clock in your phone is 30 seconds or more off the network time, the phone will automatically update to reflect the network time.



Note: Auto update time is a network dependent feature. Contact your service provider for details and availability.

- 1 Press **Menu 4-1-3** (**Settings > Time settings > Auto update of time**).
- 2 Scroll to one of the following options, then press **Select**.

On: Updates the time automatically.

Confirm first: Requires you to confirm that you want the update. You can accept or decline the update.

Off: Prevents the time from being automatically updated.

Display the clock

- 1 Press **Menu 4-1-2** (**Settings > Time settings > Clock**).
- 2 Scroll to **Hide clock** or **Show clock** (only one choice appears, depending on the current setting).
- 3 Press **Select**.

Add a welcome note

You can add a welcome note that your phone displays briefly each time you turn it on.

- 1 Press **Menu 4-3-3** (**Settings > Phone settings > Welcome note**).
- 2 Enter a note, then press **Options**.
- 3 Scroll to **Save**, then press **Select**.

To delete the welcome note, follow steps 1-2, scroll to **Delete**, then press **Select**.

Restore factory settings

If you have made changes to your phone's profiles (settings), you can restore them to their original or factory settings. The memory, timers, language selection, and security code are not reset. However, profile and accessory settings are reset.

- 1 Press **Menu 4-3-4** (**Settings > Phone settings > Restore factory settings**).
- 2 At the prompt, enter your five-digit security code and press **OK**.

See "Understand the security code" on page 66. for more information.

9 Advanced calling features

This chapter covers advanced calling features, including:

- Options available while in a call
- Managing two calls at the same time
- Network services, such as call forwarding

Not all features that are described are available in all wireless networks. Contact your service provider for availability of network services.

• UNDERSTAND ACTIVE-CALL OPTIONS

Your phone allows you to use a number of features during a call; however, you may not be able to use all options at all times. Also, the order of in-call options may vary.



Note: Many in-call options are network dependent features. To use these options, you may need to contact your service provider.

During a call, press **Options** to see the in-call menu choices:

Menu Options	What it does
Lock keys	Allows you to lock the phone's keypad during a call.
Mute	Mutes the phone's microphone. This option can affect the microphones of accessories connected to the phone.
End all calls	Ends all active calls.
Touch tones	Sends touch tones.
New call	Allows you to make a call while you have a call in progress.
Menu	Allows you to access the menus.
Contacts	Allows you to access the contact list.

Access menus

You can access your phone's menus while in a call.

- 1 Press **Options**.
- 2 Scroll to **Menu**, then press **Select**. To exit the menus, press **Exit**.



Note: Do not press the **End** key to exit the menus or you will end your call.

Make a new call

To make a new call while already in a call, dial the number, then press the **Talk** key. The first call is put on hold.

End all calls

Press the **End** key.

Access the contact list

You can access information in the contact list during a call.

- 1 Press **Options**.
- 2 Scroll to **Contacts**, then press **Select**.

Save a name and/or number

You can save a name and number during a call.

- 1 Enter the number you want to save.
- 2 Press **Options**, scroll to **Contacts**, then press **Select**.
- 3 Scroll to **Add new**, then press **Select**.

Add the name and number as you normally would.

Mute the phone's microphone

While in a call, you can mute the phone's microphone.

Press **Options**, scroll to **Mute**, press **Select**.

Use conference call

While in a call, you can call another number to add a third party to the call.



Note: Conference calling is a provider dependent feature. Contact your service provider for availability and details.

CONFERENCE A CALL

- 1 While in a call, you can either dial the number you want to add and press the **Talk** key.
OR
Press **Options**, scroll to **New call**, press **Select**, enter the phone number, and press **OK**.
- 2 When the third party answers, press the **Talk** key to connect all three parties.

DISCONNECT THIRD PARTY

While all three parties are connected, pressing the **Talk** key disconnects the third caller, keeping the second party's call active.

DISCONNECT SECOND PARTY

If you wish to disconnect with the second party and remain connected to the third party, have the second party terminate the call on his/her end.

RECALL A NUMBER FROM THE CONTACT LIST DURING A CALL

If you do not remember the number of the second party you want to include in the conference and the number is in your contact list, you can recall the number.

- 1 To access the contact list, press **Options**, scroll to **Contacts**, and press **Select**.
- 2 Follow the prompts to find the number as you normally would.
- 3 Locate the number in your contact list, then press **Select**.
The number appears in the number prompt.
- 4 Press **OK** to call the number.

END A CONFERENCE CALL

To end all calls, press the **End** key.

• USE VOICE PRIVACY

The voice privacy feature encrypts the voice channel so that people cannot eavesdrop on your phone conversations.



Note: Voice privacy is a network dependent feature. Contact your service provider for more information on this feature.

TURN VOICE PRIVACY ON/OFF

- 1 Press **Menu 4-6-1** (**Settings > Network services > Voice privacy**).
- 2 Scroll to **On** or **Off** and press **Select**.

During a call, voice privacy becomes active and notifies you with a beep. A notification message also appears on the screen.

If you turn this feature on and voice privacy becomes inactive, your phone beeps and displays **Voice privacy not active**.



Note: Use caution when sending confidential information, if voice privacy is not active.

• USE CALL FORWARDING

With call forwarding, you can forward incoming calls to another phone number. Before you can use call forwarding, you must first store the feature codes. Once call forwarding has been activated, **Call forwarding** appears as a menu option.



Note: Call forwarding is a network-dependent feature. Some networks require that call forwarding be activated manually. Contact your service provider for availability and full details.

Learn about call forwarding feature codes

Your network requires separate codes for activating and cancelling the various types of call forwarding. Your carrier can provide you with the necessary feature codes for these network services.

Once you store these feature codes in your phone, they are sent automatically to the network when you select one of the call forwarding options from your phone's menu. Your phone can store the following types of feature codes:

Option	What it does
Forward all calls	Forwards incoming calls to the number you specify.
Forward if busy	Forwards incoming calls when you are in a call.
Forward if not answered	Forwards incoming calls to another number when you are unable to answer.
Forward if out of reach	Forwards incoming calls to another number when the phone is out of the network or switched off.
Cancel all call forwarding	Cancels all active call forwarding options.

Store the call forwarding feature code

Before you can activate call forwarding, you must contact your service provider to obtain the feature codes.

- 1 Press **Menu 4-6-5 (Settings > Network services)**.
- 2 Enter the feature code your service provider gave you, then press **OK**.
- 3 Scroll to **Call forwarding** and press **Select**.
- 4 Scroll to the call forwarding option you want and press **Select**.
- 5 Scroll to **Activate** and press **Select**.

Activate/cancel call forwarding

After you store the correct feature codes, you can activate (or cancel) call forwarding as follows:

- 1 Press **Menu 4-6-2** (**Settings > Network services > Call forwarding**).
- 2 Scroll to the desired call forwarding option, then press **Select**.
- 3 Highlight **Activate** and press **Select**.
- 4 Enter the number to which you want your calls forwarded or press **Find** to recall a number from the contact list.
- 5 Press **OK**.



Note: When cancelling call forwarding, follow steps 1 and 2.

• USE CALL WAITING

During a call, call waiting beeps to let you know that someone else is calling you. Depending on your caller ID setup, the phone might also display the number of the incoming call. Once call waiting has been activated, **Call waiting** appears as a menu option.



Note: Call waiting is a network-dependent feature. In some networks the call waiting code must be activated manually. Contact your service provider for availability and full details.

Store the call waiting feature code

- 1 Press **Menu 4-6-5** (**Settings > Network services > Network feature setting**).
The **Feature code prompt** appears.
- 2 Enter the feature code issued by your service provider and press **OK**.
- 3 Scroll to **Call waiting** and press **Select**.
- 4 Scroll to **Activate** and press **Select**.

Activate call waiting

- 1 Press **Menu 4-6-3** (**Settings > Network services > Call waiting**).
- 2 Scroll to **Activate** and press **Select**.

Manage calls

Call waiting works with both local and long distance calls.

- To answer an incoming call, press the **Talk** key.
- To switch from one call to another, press the **Talk** key.
- To end both calls, press the **End** key.

• USE SEND OWN CALLER ID

This feature allows you to block caller ID when you call someone (your number will not be displayed on their caller ID). This feature is only effective when calling a number equipped with caller ID.



Note: This feature is available only when supported by the wireless network and may not function if you are roaming.



Important: This feature works on a call-by-call basis. You must enable this feature each time you want to block the sending of your own number to the recipient's caller ID.

STORE THE FEATURE CODE

Before you can use the **Send own caller ID call** feature, you must store the feature codes for activating this feature. Once the code is stored in your phone, it is sent automatically to the network when you select this option from your phone's menu.

- 1 Press **Menu 4-6-5 (Settings > Network services > Network feature setting)**.
The **Feature code** prompt appears.
- 2 Enter the feature code issued by your service provider and press **OK**.
- 3 Scroll to **Send own caller ID**, press **Select**, then select **Yes**.

PLACE A CALL WITHOUT SENDING YOUR NUMBER

- 1 Press **Menu 4-6-4 (Settings > Network services > Send own caller ID)**.
- 2 Scroll to **No**, then press **Select**.
- 3 Enter the desired phone number, then press **OK** or press **Find** to recall a phone number from the contact list.

The phone automatically inserts the feature code into the dialing string and dials the phone number. The phone you are calling will not display your phone number through caller ID.

• SELECT A PHONE NUMBER

Your service provider programs your phone number and system information into your phone's memory when your phone is first activated. Your phone can hold up to three numbers. This means that your phone can be activated in three different service areas. For example, your phone could be activated in Halifax, Winnipeg, and Vancouver. Each service area would assign a different phone number or account to your phone.

You must select a phone number for your home system. Only one phone number can be active at a time. If you travel outside your home system, you can choose another number. One phone number is usually enough if your service provider has service or roaming agreements for each area in which you wish to use your phone. Contact your service provider for details.



Note: Phone number selection is a network dependent feature. Some networks may not support more than one number. Contact your service provider for availability and full details.

Select the phone number

- 1 Press **Menu 4-6-6** (**Settings > Network services > Own number selection**).
- 2 Scroll to the phone number you want and press **Select**.



Note: The first phone number on this list is selected. You need at least one active number to make calls. You cannot change from one phone number to another during a call.

• USE AUTOMATIC REDIAL

There are times when you may not be able to place a call (for example, due to the high volume of traffic on the wireless network). When the wireless network is busy or unavailable, **Automatic redial** instructs your phone to retry the call.

ACTIVATE AUTOMATIC REDIAL

- 1 Press **Menu 4-2-1** (**Settings > Call settings > Automatic redial**).
- 2 Scroll to **On** and press **Select**.

If the system is busy, your phone makes three additional call attempts. If you want to stop the automatic redial process before the last attempt, press the **End** key or **Quit**.



Important: This feature does not automatically retry a number when the number you are calling is busy.

• USE 1-TOUCH DIALING

You can assign a name from your contact list to a 1-touch dial location, using your phone's keys 2-9. (The 1 key is used exclusively to dial your voice mailbox.) Once assigned, the phone number you associate with that key is dialed automatically when you press and hold the key.

Assign a key to 1-touch dialing

- 1 Press **Contacts**, scroll to **1-touch dialing** and press **Select**.
- 2 Scroll to a number that has the message **(empty)** and press **Assign**.
- 3 Scroll to the name and number to which you want to assign this key and press **Select**.
Repeat steps 1-3 times as many times as necessary.
- 4 To call a number using 1-touch dialing, press and hold the appropriate key for a few seconds.

Change 1-touch dialing numbers

You can change the 1-touch dialing key assignments at any time.

- 1 Press **Contacts**, scroll to **1-touch dialing**, and press **Select**.
- 2 Scroll to the key you want to change and press **Options**.
- 3 Scroll to **Change** and press **Select**.
- 4 Scroll through the contact list until you reach the new number you want to select and press **Select**.

Delete 1-touch dialing numbers

You can delete 1-touch dialing key assignments at any time.

- 1 Press **Contacts**, scroll to **1-touch dialing** and press **Select**.
- 2 Scroll to the key you want to delete and press **Options**.
- 3 Scroll to **Delete**, press **Select**, then press **OK**.

• SET TOUCH TONE STRINGS

Your phone allows you to create special sets of numbers known as touch tone strings which will dial a series of digits after a "wait" or a "pause." For example, you can program your phone to send your account number while you are banking by phone.

You must be in the **123** mode to enter these characters. Enter the numbers as usual. When you want to insert the special characters, press * repeatedly to switch among *, +, p, w characters.



Note: Use caution when sending confidential information, if voice privacy is not active.

Character	Action
p	Creates a <i>pause</i> when a number is dialed. The numbers you enter after this special character are automatically sent as touch tones after a 2.5-second pause.
w	Creates a <i>wait</i> when a number is dialed. This means that your phone waits for you to press the left selection key before it sends the number as touch tones.
*	Sends command strings to the network. Contact your service provider for details.
+	Use this character to link a 1-touch dialing number to a number in the contact list.

Set manual touch tones

- 1 Press **Menu 4-3-2-1** (**Settings > Phone settings > Touch tones > Manual touch tones**).
- 2 Select one of the following options, then press **Select**:
 - Continuous:** Sounds tone for as long as you press and hold a key.
 - Fixed:** Sets the tone length to 0.1 second, regardless of how long you press a key.
 - Off:** Turns off the tones. No tones are sent.

Set touch tone length

You can also set the length of each touch tone.

- 1 Press **Menu 4-3-2-2** (**Settings > Phone settings > Touch tones > Touch tone length**).
- 2 Use the **Scroll up** or **Scroll down** key to scroll to **Short** or **Long**.
 - Short sets the tone length to 0.1 second. Long sets the tone length to 0.5 second.
- 3 Press **Select**.

Store touch tone strings

You can store touch tone strings the same way that you store names and numbers in your contact list. You can store an entire sequence of digits and send it as touch tones for frequently used strings of numbers.

STORE TOUCH TONE STRINGS WITH PHONE NUMBERS

- 1 Enter the phone number that you want associated with a touch tone.
- 2 Enter the touch tone character where needed (p, w, or *).
- 3 Enter the touch tone string.
- 4 Store the number as you normally would.

SEND A TOUCH TONE STRING

- 1 Press **Menu 4-3-2-1** (**Settings > Phone settings > Touch tones > Manual touch tones**).
- 2 Make sure that the setting is not set to **Off**.
If not set to **Off**, scroll to one of the other options and press **Select**.
- 3 During your call, press **Options**, scroll to **Touch tones**, and press **Select**.
- 4 Enter the touch tone string or recall the string from the contact list, then press **OK**.

If you send touch tones while in the analog mode, be careful not to send confidential information.

● LINK CONTACT LIST ENTRIES

This feature allows you to store a phone number in one contact list location and link it to another contact list entry.

For example, linking the phone number of an automated service (for example, automated banking service) with a touch tone string entry in your contact list (example: account and PIN numbers) automatically recalls and sends the touch tone string when you call the service.

USE LINKING OPTIONS

- 1 Store the touch tone string into your contact list.
- 2 Assign the contact list entry with the touch tones to a one-touch dialing location (example: location 3).
For more information on 1-touch dialing, see "Use 1-touch dialing" on page 59.
- 3 Edit the automated service's phone number by adding +n to the end of the phone number (where n is the 1-touch dialing location).

Example: 214-555-1234+3

- 4 Press **OK** to save your changes.
- 5 Dial the automated service number from your contact list.

Your phone automatically sends the touch tones when the call connects.



Note: You may need to enter a pause (p) or a wait (w) before the + in order to account for delays in the automated system answering your call (for example, 214-555-1234p+3).

• SELECT A SYSTEM

Your phone can operate in residential, private, and public systems (such as your home system). You can choose how your phone selects a network to use. Your phone may not show the options described here. For information, contact your service provider.

Search for a network

Press **Menu 5 (System)**.

You have the following three options:

- **Automatic:** Your phone automatically searches for available networks and chooses the appropriate one. Every time you turn on your phone, it resets to **Automatic**.
- **Manual:** The phone searches for networks and then shows a list of the ones that are available. If an available network is found, **Available:** appears on the screen, followed by the name of the network. To choose the network listed, press **OK**.
- **New search:** Your phone begins a new search for both private and residential systems. When it finds the best system available, the phone shows the system name. If the phone does not find another system, the question **Perform an extended search?** will appear. Press **OK** if you wish to continue searching.

Select a public system

When you take your phone outside its home system, the phone is said to be *roaming*. The phone can search for home-type systems (that is, systems of the same type as your home system). Or, the phone can search for non-home-type systems.

Your service provider programs a list of preferred systems into your phone. These are systems with which your service provider has roaming agreements. Your phone looks for these systems when you are roaming.



Note: The options described here may not be available for your phone. Contact your service provider for information.

- 1 Press **Menu 4-6-7 (Settings > Network services > Public system selection)** to tell your phone how to choose a public system (network).

Your selection remains active until you change it.

- 2 Scroll to one of the following options, then press **Select**.

Any system: When service is not available in your home system, the phone searches for a preferred system of either type and then searches for a home-type system. Then it searches for a nonhome-type system. The search continues until your phone finds a system that can be used.

Home type: When service is not available in your home system, the phone searches for a home-type system first. However, if a nonhome-type system is found, your phone will use that system.

Nonhome type: The phone searches for a nonhome-type system only. The home-type system is not used.

Home only: The phone uses only its home system. It will not roam.

Select digital or analog

Your phone can work in both digital and analog modes. The default mode is both digital and analog, which appears on your phone as **Digital & analog** when you press **Menu 4-6-8 (Settings > Network services > Digital/analog selection)**.

The menu options for choosing the mode you prefer are:

- **Digit. & analog**
- **Analog**
- **Digital**

Your phone uses both digital and analog voice channels. The phone always tries to find a digital voice channel first, but if a digital voice channel is not available, the phone looks for an analog voice channel.



Note: This feature is available only for certain phones. Contact your service provider for more information.

10 Security

Your phone is equipped with different security features that allow you to do the following:

- Avoid making accidental calls
- Prevent unauthorized users from changing certain feature settings on your phone
- Restrict outgoing or incoming calls

• USE KEYGUARD

Keyguard disables your keypad to prevent accidental key presses.

LOCK THE KEYPAD

To lock the keys, press **Menu** then *****.

UNLOCK THE KEYPAD

To unlock the keys, press **Unlock** then *****.

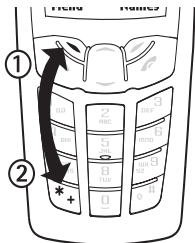

Note: When Keyguard is on, calls may be possible to emergency numbers (for example, 911 or other official emergency number). Key in the emergency number and press the **Talk** key. The number is displayed only after you have keyed in its last digit.

Answer a call while Keyguard is active

You can answer calls when Keyguard is activated by pressing **Answer** or the **Talk** key. If you are connected to a headset or loopset, press and hold the **End** key to end the call.

NOTES ABOUT KEYGUARD

- After you end the call, Keyguard automatically becomes active again.
- If you need the phone's lights while Keyguard is on, press the **Power** key to quickly switch the lights on for 15 seconds.
- Connecting your phone to a car kit automatically disables Keyguard.

• UNDERSTAND THE SECURITY CODE

The Security code prevents unauthorized users from changing certain important feature settings on your phone. When the phone requires this code, it displays a prompt asking you to enter a Security code. The five-digit default Security code that comes with your phone is 12345. Nokia recommends that you change the default code immediately.



Note: If you enter an incorrect security code five times in a row, the phone will not accept the correct code for 5 minutes.

Change your security code

- 1 Press **Menu 4-5-2 (Settings > Security settings > Change security code)**.
- 2 At the **Security code** prompt, enter your five-digit default security code (12345) or your current security code and press **OK**.
- 3 At the **Enter new security code** prompt, enter your new five-digit security code and press **OK**.
- 4 At the **Verify new security code** prompt, enter your new security code again and press **OK**.

The confirmation **Security code changed** appears.

Keep your security code secret and stored in a safe place away from your phone. If you have changed your security code and do not remember the new code, contact your service provider.

• RESTRICT CALLS

You can create your own list of restrictions to restrict incoming and outgoing calls. To restrict the calls, you apply the appropriate restriction as desired. The maximum number of call restrictions you can define is ten.

Before you define restrictions for outgoing calls, **Add restriction** is the only available option. After you use the **Add restriction** option to add at least one restriction, the following options become available:

- **Select:** Allows you to select call restrictions from the outgoing calls list.
- **Add restriction:** Allows you to add a new restriction.
- **Edit:** Allows you to edit an existing call restriction.
- **Delete:** Allows you to delete an existing call restriction.



Note: When calls are restricted, calls may be possible to the emergency number programmed into your phone (for example, 911 or other official emergency number). For example, you could dial 911 and press the **Talk** key.

Add a number to the call restriction list

- 1 Press **Menu 4-5-1-1** (**Settings > Security settings > Call restrictions > Restrict outgoing calls**).
- 2 Enter your security code, then press **OK**.
- 3 Scroll to **Restrict outgoing calls**, then press **Select**.
- 4 Scroll to **Add restriction** and press **Select**.
- 5 At the number prompt, enter the number you want to restrict, and press **OK**.
For example, if you want to restrict all long distance calls that begin with 1, enter 1. If you want to restrict all calls that begin with 972, enter 972.
- 6 Enter a name for the restriction, then press **OK**.
If you press **OK** without entering a name, the number will be used.

Restrict outgoing calls

- 1 Press **Menu 4-5-1-1** (**Settings > Security settings > Call restrictions > Restrict outgoing calls**).
- 2 Enter your security code, then press **OK**.
- 3 Scroll to **Restrict outgoing calls**, then press **Select**.
- 4 Scroll to **Select** to choose from your list of call restrictions.
To deactivate a call restriction, highlight the restriction and press **Unmark**.
- 5 Scroll to the restriction you want to activate and press **Mark**.
- 6 Press **Back**.
- 7 At **Save changes?**, press **Yes**.
To return to the start screen, press the End key.

Restrict all incoming calls

- 1 Press **Menu 4-5-1-2** (**Settings > Security settings > Call restrictions > Restrict incoming calls**).
- 2 Enter your security code, then press **OK**.
- 3 Scroll to **Restrict incoming calls**, then press **Select**.
- 4 Press **Mark** to restrict all incoming calls.

11 Special features

This section describes several special features, including transmission of business cards, using the calculator and setting the alarm clock.

• USE THE ALARM CLOCK

The alarm clock feature is based on your phone's internal clock and sounds an alert at a time you specify. The alarm clock works even if you turn your phone off.

Set the alarm clock

- 1 Press **Menu 4-1-1** (**Settings > Time settings > Alarm clock**).
- 2 Enter the alarm time in **hh:mm** format, then press **OK**.
Step 3 is necessary only if you have selected **am/pm** format.
- 3 Select either **am** or **pm**, then press **Select**.

Respond to the alarm

At the time of the alarm, the phone sounds an alert tone. Pressing **Stop** or the **End** key stops the alarm from sounding, and returns you to the start screen.

SNOOZING

There are several ways you can enable the **Snooze** feature:

- 1 Press the **Snooze** selection key.
- 2 Press any key except the **End** key.
- 3 Allow the alarm to sound for one minute.

Once snooze is enabled, the alarm will sound again in ten minutes. If you press **Stop** or the **End** key while snoozing, the alarm will be turned off.

Alarm when phone power is off

If the alarm time is reached while the phone is off, the phone switches itself on and starts sounding the alarm tone. If you press **Stop**, the phone asks whether you want to activate the phone for calls. Press **No** to switch off the phone or **Yes** to make and receive calls.



Note: Do not press **Yes** when wireless phone use is prohibited or when it may cause interference or danger.

Turn off the alarm clock

- 1 Press **Menu 4-1-1** (**Settings > Time settings > Alarm clock**).
- 2 Scroll to **Off** and press **Select**.

• USE THE CALCULATOR

The calculator adds, subtracts, multiplies, divides and converts currencies.

- 1 Press **Menu 7 (Calculator)**
- 2 Enter the first number in the calculation. To enter a decimal point, press **#**. Press **Clear** to delete any mistakes.
- 3 Press **Options** and scroll to **Add, Subtract, Multiply, or Divide**. Press **OK**.

Based upon the type of calculation, you also can use the following shortcut keys:

If you want to...	Press...
add	* (for + symbol)
subtract	** twice (for - symbol)
multiply	*** (for * symbol)
divide	**** (for / symbol)

- 4 Enter the second number in the calculation and press **Options**.
Equals appears.
- 5 Press **OK**.
- 6 Repeat steps 2-6 as many times as necessary.

Your phone must be switched on to use this function. Do not switch the phone on when wireless phone use is prohibited or when it may cause interference or danger.



Note: This calculator has a limited accuracy and rounding errors may occur, especially in long divisions.

Convert currency

You can use the calculator function to set an exchange rate and then calculate prices based on that exchange rate.

SET THE EXCHANGE RATE

- 1 Press **Menu 7 (Calculator)**, then press **Options**.
- 2 Scroll to **Exchange rate**, press **OK** and select one of the following options:
 - **Foreign units converted to home units** – allows you to enter the number of foreign units to a domestic unit.
 - **Home units converted to foreign units** – allows you to enter the number of domestic units to a foreign unit.

- 3 Press **OK**, enter the appropriate exchange rate (press **#** to enter a decimal point) and press **OK**.

The initial default of 1 is overwritten by any number you enter and the **Rate saved** confirmation appears.

CONVERT A CURRENCY AMOUNT

- 1 Press **Menu 7 (Calculator)**.
- 2 Enter the amount which you wish to convert.
- 3 Press **Options** and scroll to one of the following options:
 - **To home** – converts visited units of currency to *home* units using the exchange rate.
 - **To foreign** – converts home units of currency to *visited* units using the exchange rate.
- 4 Press **OK**.

• BUSINESS CARDS

Your phone can send or receive electronic business cards consisting of a name, phone number and e-mail. You can save received business cards in your contact list. This is a network dependent feature.

Send a business card

- 1 Find the name in your contact list. If **Details** appears, press **Details**.
- 2 Press **Options** and scroll to **Send bus. card**.
- 3 Press **Select**.
- 4 Enter or recall the phone number to which you want to send the business card and press **Send**.

View a received business card

When you receive a business card, the phone displays **Business card received**.

- 1 When your phone displays **Business card received**, press **Options**.
- 2 **Show** is selected. Press **Select**.
- 3 Scroll through the available information.

Save a viewed business card

- 1 After viewing the business card, press **Back**, scroll to **Save** and press **Select**.
- 2 At the **Name:** prompt, edit the name if desired, then press **OK**.

- 3 At the **Number:** prompt, edit the number if desired, then press **OK**.
- 4 At the **E-mail** address prompt, edit the e-mail address if desired, then press **OK**.

Delete a viewed business card

After viewing the business card:

- 1 Press **Back**.
- 2 Scroll to **Discard**, then press **Select**.
- 3 **Discard business card?** appears, press **OK**.

• DOWNLOAD A RINGING TONE

You can download up to ten ringing tones to replace the personal entries in your list of ringing tones. Since this is a network dependent feature, methods for downloading ringing tones vary. Some wireless providers allow you to send ringing tones to your phone via the Internet, but may charge for this service. Please contact your wireless service provider for details.

Notification of a received ringing tone

If you have this service and your phone receives a downloaded ringing tone, your phone displays **Ringling tone received**.

Listen to received ringing tones

- 1 When your phone shows **Ringling tone received**, press **Options**.
- 2 **Playback** is selected. Press **OK**.
The phone plays the ringing tone.
- 3 To stop playing the ringing tone, press **Quit**.



Note: An incoming call or pressing any key stops the ringing tone from playing.

Save a received ringing tone

- 1 After listening to the ringing tone, press **Quit**.
- 2 Scroll to **Save tone**. Press **OK**.
- 3 Choose which ringing tone you want to replace - either an empty **Personal** location, if any are remaining, or a previously downloaded tone.

Discard a received ringing tone

- 1 After listening to the ringing tone, press **Quit**.
- 2 Scroll to **Discard tone**, then press **OK**.

12 Games

You can use your phone for communication *and* some serious fun. Your phone offers three games:

- Snake II
- Space impact
- Pairs II



Note: Your phone must be switched on to use this function. Do not switch on the phone when wireless phone use is prohibited or when it may cause interference or danger.

• START A NEW GAME

- 1 Press **Menu 6 (Games)**.
- 2 Scroll to the desired game and press **Select**.
- 3 Select **New game**, then press **Select**.

Additional options for each game include:

Option	What it does
Continue	Continue a game that was stopped.
New Game	Start a new game.
Level (Snake II and Pairs II only)	Choose the game's difficulty level.
Mazes (Snake II only)	Choose among different maze designs.
Top score	Display the top score.
Instructions	Learn how to play the game.
Time trial (Pairs II only)	To advance to the next level, you must pair up all tiles before the dynamite fuse runs out.
Puzzle (Pairs II only)	Reveal pictures to find pairs with as few tries as possible.

GAME SETTINGS

Game sounds and lights can be turned on or off. To access the **Settings** menu, press **Menu 6-4 (Games > Settings)**.

• SNAKE II

Feed the snake with as many goodies as possible and watch it grow. Press **Menu 6-1**.

To turn the snake toward the food, press **2, 4, 6, and 8**. The longer the snake's tail grows, the higher your score. You can choose to have a clear field, or select from five different mazes. If the snake runs into its own tail or the surrounding wall, found in one of the maze levels, the game is over.

• SPACE IMPACT

Use your weapons to survive alien attacks. When you defeat all the enemies, you progress to the next level. Press **Menu 6-2**.

- To move up and down, press **8** and **0**.
- To move to the left and right, press ***** and **#**.
- To fire the main weapons, press **1** or **3**.
- To fire the bonus weapons, press **4** or **6**.

• PAIRS II

The object of the game is to uncover the pictures to find pairs in as few tries as possible. Press **Menu 6-3** and choose between **Time Trial** and **Puzzle**.

Move the cursor with keys **2, 4, 5, and 8**.

To reveal the pictures, press **5**.

When playing in **Time trial** mode, you must match all the pairs before the dynamite fuse runs out in order to advance to the next level.

13 Reference information

This section provides information about your phone's batteries, accessories, chargers, safety guidelines and technical information. Be aware that the information in this section is subject to change as batteries, chargers, and accessories change.

• BATTERY STATEMENTS

Charging and discharging

Your phone is powered by a rechargeable battery.

Note that a new battery's full performance may be achieved only after two or three complete charge and discharge cycles!

The battery can be charged and discharged hundreds of times but it will eventually wear out. When the operating time (talk time and standby time) is noticeably shorter than normal, it is time to buy a new battery.

Use only batteries approved by the phone manufacturer and recharge your battery only with the chargers approved by the manufacturer. Unplug the charger when not in use. Do not leave the battery connected to a charger for longer than a week, since overcharging may shorten its lifetime. If left unused, a fully charged battery will discharge itself over time.

Temperature extremes can affect the ability of your battery to charge; allow it to cool down or warm up first.

For good operation times with NiMH batteries, discharge the battery from time to time by leaving your phone switched on until it turns itself off (or by using the battery discharge facility of any approved accessory available for your phone). Do not attempt to discharge the battery by any other means.

Use the battery only for its intended purpose.

Never use any charger or battery which is damaged or worn out.

Do not short-circuit the battery. Accidental short-circuiting can occur when a metallic object (coin, clip, or pen) causes direct connection of the + and - terminals of the battery (metal strips on the battery), for example, when you carry a spare battery in your pocket or purse. Short-circuiting the terminals may damage the battery or the connecting object.

Leaving the battery in hot or cold places, such as in a closed car in summer or winter conditions, will reduce the capacity and lifetime of the battery. Always try to keep the battery between 15°C and 25°C (59°F and 77°F). A phone with a hot or cold battery may temporarily not work, even when the battery is fully charged. Batteries' performance is particularly limited in temperatures well below freezing.

Do not dispose of batteries in a fire!

Dispose of batteries according to applicable local regulations (for example, recycling). Do not dispose of as household waste.



Note: For information on how to charge and recharge your battery, refer to "Important battery information" on page 12.

• PROPER CARE AND MAINTENANCE

Your phone is a product of superior design and craftsmanship and should be treated with care. The suggestions below will help you to fulfill any warranty obligations and to enjoy this product for many years:

- Keep the phone and all its parts and accessories out of the reach of small children.
- Keep the phone dry. Precipitation, humidity and all types of liquids or moisture can contain minerals that will corrode electronic circuits.
- Do not use or store the phone in dusty, dirty areas. Its moving parts can be damaged.
- Do not store the phone in hot areas. High temperatures can shorten the life of electronic devices, damage batteries, and warp or melt certain plastics.
- Do not store the phone in cold areas. When it warms up (to its normal temperature), moisture can form inside and may damage electronic circuit boards.
- Do not attempt to open the phone. Non-expert handling may damage it.
- Do not drop, knock, or shake the phone. Rough handling can break internal circuit boards.
- Do not use harsh chemicals, cleaning solvents, or strong detergents to clean the phone.
- Do not paint the phone. Paint can clog the moving parts and prevent proper operation.
- Use only the supplied or an approved replacement antenna. Unauthorized antennas, modifications, or attachments could damage the phone and may violate regulations governing radio devices.

All of the above suggestions apply equally to your phone, battery, charger or any accessory. If any of them are not working properly, take them to your nearest qualified service facility. The personnel there will assist you, and if necessary, arrange for service.

● IMPORTANT SAFETY INFORMATION

This section provides additional safety information. A brief overview of safety can be found in "For your safety" on page 1.

Traffic safety

Do not use a hand-held telephone while driving a vehicle. Always secure the phone in its holder; do not place the phone on the passenger seat or where it can break loose in a collision or sudden stop.

Remember road safety always comes first!

Operating environment

Remember to follow any special regulations in force in any area and always switch off your phone whenever it is forbidden to use it, or when it may cause interference or danger.

Use the phone only in its normal operating positions.

Parts of the phone are magnetic. Metallic materials may be attracted to the phone, and persons with a hearing aid should not hold the phone to the ear with the hearing aid. Always secure the phone in its holder, because metallic materials may be attracted by the earpiece. Do not place credit cards or other magnetic storage media near the phone, because information stored on them may be erased.

Electronic devices

Most modern electronic equipment is shielded from radio frequency (RF) signals. However, certain electronic equipment may not be shielded against the RF signals from your wireless phone.

PACEMAKERS

Pacemaker manufacturers recommend that a minimum separation of 20 cm (6-8 inches) be maintained between a hand-held wireless phone and a pacemaker to avoid potential interference with the pacemaker. These recommendations are consistent with the independent research by and recommendations of Wireless Technology Research. Persons with pacemakers:

- Should always keep the phone more than 20 cm (8 inches) from their pacemaker when the phone is switched on
- Should not carry the phone in a breast pocket
- Should use the ear opposite the pacemaker to minimize the potential for interference.
- If you have any reason to suspect that interference is taking place, switch off your phone immediately.

HEARING AIDS

Some digital wireless phones may interfere with some hearing aids. In the event of such interference, you may want to consult your service provider.

Other medical devices

Operation of any radio transmitting equipment, including wireless phones, may interfere with the functionality of inadequately protected medical devices. Consult a physician or the manufacturer of the medical device to determine if it is adequately shielded from external RF energy or if you have any questions. Switch off your phone in health care facilities when any regulations posted in these areas instruct you to do so. Hospitals or health care facilities may be using equipment that could be sensitive to external RF energy.

Vehicles

RF signals may affect improperly installed or inadequately shielded electronic systems in motor vehicles (for example, electronic fuel injection systems, electronic antiskid/antilock braking systems, electronic speed control systems, air bag systems). Check with the manufacturer or its representative regarding your vehicle. You should also consult the manufacturer of any equipment that has been added to your vehicle.

POSTED FACILITIES

Switch your phone off in any facility where posted notices so require.

Potentially explosive atmospheres

Switch off your phone when in any area with a potentially explosive atmosphere and obey all signs and instructions. Sparks in such areas could cause an explosion or fire resulting in bodily injury or even death.

Users are advised to switch off the phone when at a refuelling point (service station). Users are reminded of the need to observe restrictions on the use of radio equipment in fuel depots (fuel storage and distribution areas), chemical plants, or where blasting operations are in progress.

Areas with a potentially explosive atmosphere are often but not always clearly marked. They include below deck on boats; chemical transfer or storage facilities; vehicles using liquefied petroleum gas (such as propane or butane); areas where the air contains chemicals or particles, such as grain, dust, or metal powders; and any other area where you would normally be advised to turn off your vehicle engine.

Vehicles

Only qualified personnel should service the phone or install the phone in a vehicle. Faulty installation or service may be dangerous and may invalidate any warranty which may apply to the unit.

Check regularly that all wireless phone equipment in your vehicle is mounted and operating properly.

Do not store or carry flammable liquids, gases or explosive materials in the same compartment as the phone, its parts or accessories.

For vehicles equipped with an air bag, remember that an air bag inflates with great force. Do not place objects, including both installed or portable wireless equipment in the area over the air bag or in the air bag deployment area. If in-vehicle wireless equipment is improperly installed and the air bag inflates, serious injury could result.

Aircraft

Switch off your phone before boarding an aircraft. The use of wireless telephones in an aircraft may be dangerous to the operation of the aircraft, disrupt the wireless telephone network, and may be illegal.

Failure to observe these instructions may lead to suspension or denial of telephone services to the offender, legal action or both.

• MAKE EMERGENCY CALLS



Important: This phone, like any wireless phone, operates using radio signals, wireless, and landline networks as well as user-programmed functions. Because of this, connections in all conditions cannot be guaranteed. Therefore you should never rely solely upon any wireless phone for essential communications (for example, medical emergencies).

Emergency calls may not be possible on all wireless phone networks or when certain network services and/or phone features are in use. Check with local service providers.

To make an emergency call

- 1 If the phone is not on, switch it on, then check for adequate signal strength.
- 2 Press the **End** key as many times as needed (for example, to exit a call, to exit a menu, etc.) to clear the display and ready the phone for calls.
- 3 Key in the emergency number for your present location (for example, 911 or other official emergency number). Emergency numbers vary by location.
- 4 Press the **Talk** key.

If certain features are in use, (keyguard, etc.) you may first need to turn those features off before you can make an emergency call. Consult this user guide and your local wireless service provider.

When making an emergency call, remember to give all the necessary information as accurately as possible. Remember that your wireless phone may be the only means of communication at the scene of an accident – do not end the call until given permission to do so.

• CERTIFICATION INFORMATION (SAR)

THIS MODEL PHONE MEETS THE GOVERNMENT'S REQUIREMENTS FOR EXPOSURE TO RADIO WAVES.

Your mobile phone is a radio transmitter and receiver. It is designed and manufactured not to exceed the limits for exposure to radio frequency (RF) energy set by Industry Canada. These limits are part of comprehensive guidelines and establish permitted levels of RF energy for the general population. The guidelines are based on standards that were developed by independent scientific organisations through periodic and thorough evaluation of scientific studies. The guidelines include a substantial safety margin designed to assure the safety of all persons, regardless of age and health.

The exposure standard for mobile phones employs a unit of measurement known as the Specific Absorption Rate, or SAR. The SAR limit set by the Industry Canada is 1.6 W/kg* Tests for SAR are conducted using standard operating positions with the phone transmitting at its highest certified power level in all tested frequency bands. Although the SAR is determined at the highest certified power level, the actual SAR of the phone while operating can be well below the maximum value.

This is because the phone is designed to operate at multiple power levels so as to use only the power required to reach the network. In general, the closer you are to a base station, the lower the power output of the phone.

Before a phone model is available for sale to the public, compliance with the Canadian Standard must be shown. The following values are the highest SAR values for this model phone.

When tested for use at the ear -

FCCID # GMLRH-40 is 1.23 W/kg

FCCID # GMLRH-39 is 1.08 W/kg

When worn on the body, as described in this user guide:

FCCID # GMLRH-40 is 1.18W/kg

FCCID # GMLRH-39 is 0.96 W/kg

(Body-worn measurements differ among phone models, depending upon available accessories and Industry Canada requirements).

While there may be differences between the SAR levels of various phones and at various positions, they all meet the government requirement for RF exposure.

* The SAR limit for mobile phones used by the public is 1.6 watts/kilogram (W/kg) averaged over one gram of body tissue. The standard incorporates a substantial margin of safety to give additional protection for the public and to account for any variations in measurements. SAR values may vary depending on national reporting requirements and the network band. For SAR information in other regions please look under product information at www.nokia.com.

● ENHANCEMENT SAFETY

This section provides information about the phone's batteries, chargers, and enhancements. Be aware that the information in this section is subject to change as the batteries, chargers, and enhancements change.

Check the model number of any charger before use with this phone. This device is intended for use when supplied with power from an ACP-7U, ACP-8U, ACP-12U or LCH-9 charger.



Warning: Use only Nokia original enhancements or batteries, chargers, and accessories approved by Nokia, for use with this Nokia phone model. The use of any other types may invalidate any approval or warranty applying to the phone, and may be dangerous.

For availability of approved enhancements, please check with your dealer.

When you disconnect the power cord of any accessory, grasp and pull the plug, not the cord.

When you are not using a charger, disconnect it from the power source.

When the battery is running out of power and your phone only has a few minutes of talk time remaining, a warning tone sounds and the **Battery low** message appears briefly. When no more talk time is left, a warning tone is sounded and the phone switches itself off.

Practical rules for enhancement operation

- Keep all enhancements out of reach of small children.
- When you disconnect the power cord of any enhancement, grasp and pull the plug, not the cord.
- Check regularly that any vehicle-installed enhancements are mounted and are operating properly.
- Installation of any complex car enhancements must be made by qualified personnel only.
- Use only batteries, chargers, and enhancements that have been approved by the phone manufacturer. The use of any other types could invalidate any approval or warranty applying to the phone and could be dangerous. Refer to "Enhancement safety" on page 80 for important battery usage information.

Batteries

This section provides information about the phone's battery. Be aware that the information in this section is subject to change.



Note: Dispose of used batteries in accordance with any local regulations.

The tables shown in this section provide information about the batteries that are available for your phone, charging times with the Rapid Travel Charger (ACP-8U and ACP-12U), the Standard Travel Charger (ACP-7U), talk times, and standby times. Consult your service provider for more information.

Charging times

The charging times listed below are approximate.

Battery option	ACP-7U Charger	ACP-8U Charger	ACP-12U Charger
BMC-3 NiMH Battery 900 mAh	up to 4 hours	up to 2 hours	up to 1 hour, 40 minutes

Standby and talk times

Battery talk and standby times are estimates only and depend on signal strength, network conditions, features used, battery age and condition (including the effect of charging habits), temperatures to which the battery is exposed, use in digital mode, and many other factors. Please note that the amount of time a phone is used for calls will affect its standby time. Likewise, the amount of time that the phone is turned on and in standby mode will affect its talk time.

Battery option	Talk time		Standby Time	
	Digital	Analog	Digital	Analog
BMC-3 NiMH Battery 900 mAh	up to 5 hours	up to 2 hours	up to 15 days	up to 2 days
BLC-2 Li-Ion Battery 1000 mAh	up to 5 hours	up to 2 hours	up to 16 days	up to 2 days

• ENHANCEMENTS

If you want to enhance the functionality of your phone, a range of enhancements is available for you. You can select any of these items to help accommodate your specific communication needs. For availability of these and other enhancements, contact your service provider.





Warning: Use only Nokia original enhancements, or batteries, chargers and enhancements approved by Nokia, for use with this Nokia phone model. The use of any other types may invalidate any approval or warranty applying to the phone, and may be dangerous.

900 mAh NiMH Battery (BMC-3)

Provides up to 5 hours of digital talk time and up to 15 days of digital standby time. Provides up to 2 hours of analog talk time and up to 2 days of analog standby time.



Note: Operation times are estimates and may vary depending on network conditions, charging and phone use.

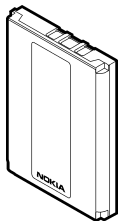

1000 mAh Li-Ion Battery (BLC-2)

Provides up to 5 hours of digital talk time and up to 16 days of digital standby time. Provides up to 2 hours of analog talk time and up to 2 days of analog standby time.



Note: Operation times are estimates and may vary depending on network conditions, charging and phone use.

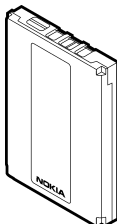

Standard Travel Charger (ACP-7U)

The Standard Travel Charger is a lightweight (187 g) and durable AC charger.

To use the Standard Travel Charger, plug it into a standard 120 V AC wall outlet and connect the lead from the charger to the base of your phone.



Note: If the battery is completely empty, you cannot use the phone until it has enough charge to operate.

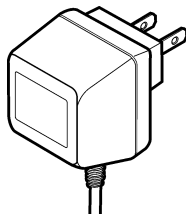

Rapid Travel Charger (ACP-8U)

The Rapid Travel Charger is a lightweight (100 g) and durable AC charger. Calls can be made during charging, even with a fully discharged battery.

To use the Rapid Travel Charger (ACP-8U), plug it into a standard 120 or 220 V AC wall outlet, and connect the lead from the charger to the base of your phone.

Approximate charging times for discharged batteries are shown in "Charging times" on page 81.

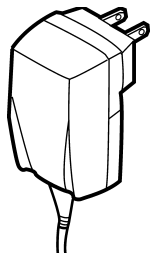

Rapid Travel Charger (ACP-12U)

The Rapid Travel Charger is a lightweight and durable AC charger. Calls can be made during charging, even with a fully discharged battery.

To use the Rapid Travel Charger (ACP-12U), plug it into a standard 120 or 220 V AC wall outlet, and connect the lead from the charger to the base of your phone.

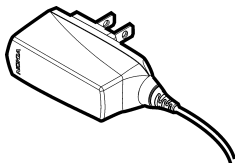

Rapid Cigarette Lighter Charger (LCH-9)

You can charge your phone's battery from your vehicle battery by using the Rapid Cigarette Lighter Charger (LCH-9).

Calls are possible during charging. A green light indicates that the charger is ready for charging. The battery charging times are the same as those for the Rapid Travel Charger (ACP-8U).

The input voltage range is from 11-24 V DC, negative grounding. Avoid prolonged charging with the Rapid Cigarette Lighter Charger (LCH-9) when the car engine is not running; this could cause your car battery to drain. Note also, that in some cars, the cigarette lighter plug is not provided with electricity if the ignition is not switched on.

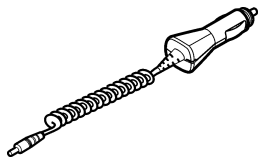

Spare Battery Charger (DDC-1)

Lightweight and stylish, this charger provides a convenient way to charge your spare battery.

This charger is compatible with the Standard Travel Charger (ACP-7) and the Rapid Travel Charger (ACP-8).

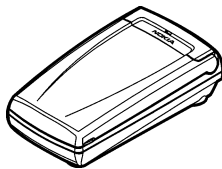

Headset (HDC-5)

Small and lightweight, the headset allows easy and convenient hands-free operation. The headset has a foam earpiece cover for a comfortable fit and has a clip to hold it firmly in place. This headset's 4-wire 2.5 mm plug fits directly into the bottom of the phone. A remote control button located in the microphone makes the headset convenient to use while answering or receiving calls.

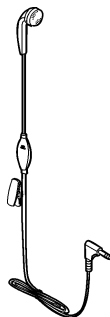

Headset (HDE-2)

Small and lightweight, the headset allows easy and convenient hands-free operation. This headset comes with a clip for a comfortable fit. This headset's 4-wire 2.5 mm plug fits directly into the bottom of your phone.

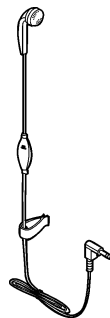

Boom Headset (HDB-5)

Compact and functional, the Boom Headset provides you with convenient, portable hands-free facility. This headset offers a new and modern "over the ear" concept with a stylish design and basic hands-free functionality, including the answer/end button.

This headset's 4-wire 2.5 mm plug fits directly into the bottom of your phone.



Retractable Headset Kit (HDC-10)

Compact and functional, this headset provides you with convenient, portable, hands-free operation. The retractable mechanism and remote control provide easy operation.

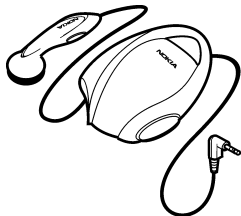

Loopset (LPS-3)

With the Nokia Loopset, people who use a T-coil equipped hearing aid have the freedom to talk on a digital mobile phone. The loopset goes around your neck - so it can be worn comfortably and discreetly.

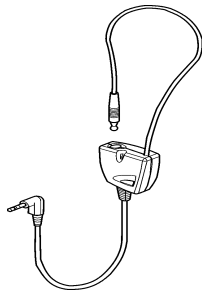

TTY/TDD Adapter (HDA-9)

The TTY/TDD Adapter is a Nokia accessory that allows you to connect your mobile phone to a Telecommunications Device for the Deaf (TTY/TDD) to make a call in digital mode.

WHAT YOU WILL NEED

Here is what you will need for TTY/TDD communication.

- A TTY/TDD device that is "cellular ready" or "cellular compatible"
- A cable for connecting the TTY/TDD to your phone, usually supplied by the manufacturer of the TTY/TDD device.
- The TTY/TDD Adapter (HDA-9), which can be purchased separately as an accessory.

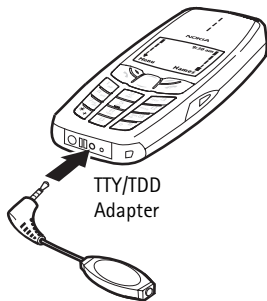

Mobile Holder (MBC-6K)

Small and easy to use, the Mobile Holder provides an ideal place to hold the phone in a vehicle. The Mobile Holder is easy to attach to the dashboard via a mounting plate or swivel. The Mobile Holder is compatible with the Rapid Cigarette Lighter Charger (LCH-9) and the Express Car Kit (PPH-1).

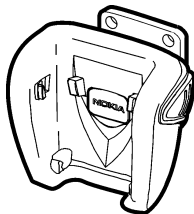

Express Car Kit (CARK-125)

This car kit provides charging and hands-free functionality. With excellent audio quality, the car kit is easy to use and is compatible with 12 V systems.

The Express Car Kit includes a holder and plug-in, hands-free, and external microphone.

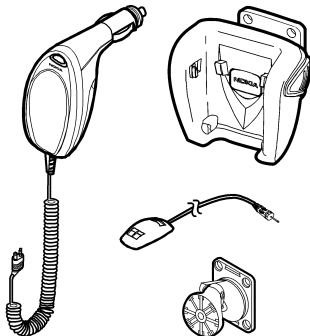

Express Car Kit (PPH-1)

The Express Car Kit provides charging and hands-free functionality. Compatible with 12 V systems, the Express Car Kit plugs into the cigarette lighter socket for charging. A green light indicates readiness for charging. The Express Car Kit has a built in speaker and uses the phone's microphone. The Express Car Kit also has a connector for the external microphone (HFM-8). The microphone should be installed 20 inches apart from the external speaker.

The Express Car Kit requires no screws for installation and thus can be moved easily from car to car.

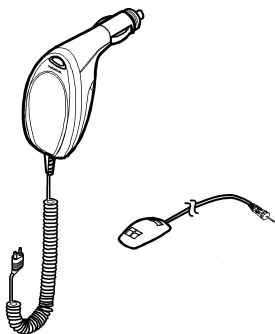

Full Car Kit (CARK-134)

The Full Car Kit (CARK-134) offers a convenient hands-free option, automatic charging facility, transmission capacity with external antenna connection and car radio mute.

The Full Car Kit contains the following:

- HHS-9 Swivel Mount
- HFU-5 Junction Box
- MKU-1 Mounting Plate
- HFM-8 Handsfree Microphone
- HFS-12 External Handsfree Speaker
- PCH-4J Power Cable

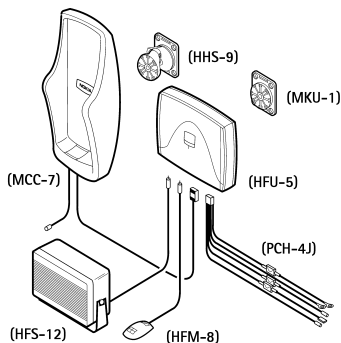

Carry case (CSM-6)

Handsome leather case helps protect your phone and allows for easy keypad access. The clip attaches to your belt for convenience.



Nokia Xpress-on™ colour covers

The Xpress-on™ cover is available in several fashion colours. Extra covers may be purchased from your authorized Nokia dealer.



Note: Before changing the cover, always switch off the power and disconnect the phone from the charger or any other device. Always store the phone with covers attached.

REMOVE THE BACK COVER

- 1 Switch off the power and disconnect the phone from the charger or any other device.
- 2 Push in the release button on the back of the phone, slide the cover toward the top of the phone, and remove it.

REMOVE THE FRONT COVER

- 1 Use the finger rests on each side of the phone and hold the phone face down.
- 2 While holding the phone, place your finger on the groove between the phone and the cover.
- 3 Gently pry the front cover away from the phone and lift the phone out of the cover.

REMOVE THE KEYPAD

- 1 Lift the keypad from the inside of the front cover.
- 2 Place the keypad into the new front cover.

REPLACE THE FRONT COVER

- 1 Slide the top of the phone into the top of the front cover.
Be careful to align the power key/IR port with its place in the top of the front cover.
- 2 Gently push the bottom of the phone into the bottom of the front cover until it snaps into place.

REPLACE THE BACK COVER

- 1 Insert the two catches of the back cover in the corresponding slots in the phone.
- 2 Slide the cover towards the bottom of the phone until it locks into place.

• TECHNICAL INFORMATION

Feature	Specification
Weight	4.23 oz with BLC-2 battery 5.17 oz with BMC-3 battery
Volume	108 cc
Frequency Range	Lowband 824.04 - 848.97 MHz (TX) 869.04 - 893.97 MHz (RX) Highband 1850.04 - 1909.92 MHz (TX) 1930.08 - 1989.96 MHz (RX)
Transmitter Output Power	Up to 600 mW
Battery Voltage	3.6 V nominal
Operating Temperature	-4°F to + 104°F (-20°C to + 40°C)
Number of Channels	832 lowband 1997 highband
Phone Numbers	Up to 3
Contact List Locations	Up to 200

• TROUBLESHOOTING

This section lists some of the most commonly encountered problems and provides possible solutions.

Problem	Possible cause	Possible solution
My phone is not charging.	The charger and the phone are not properly connected.	Securely connect the charger to the phone.
	The charger is not properly plugged in.	Ensure that the charger is plugged in correctly.
My phone is not making or answering calls.	The battery is not charged.	Charge the battery.
	The signal strength is too low.	If you are indoors, move toward a window.
I cannot listen to my voice messages.	You do not have voice mail service.	This is a service provider dependent feature. Please call your wireless service provider.
	The voice mail number you have saved is incorrect.	
	You have forgotten your password or are entering in incorrectly.	
	Your voice mail number is not saved in the phone.	Refer to "Save the voice mailbox number" on page 37.

Nokia One-Year Limited Warranty

Nokia warrants that the Nokia wireless phone and enhancements are free from defects in material and workmanship. The warranty period for the Phone (Radio) units and all enhancements (excluding carry cases) is twelve (12) months from the date of purchase OR fourteen (14) months from date of wholesale shipment from Nokia, OR fifteen (15) months from the date of manufacture by Nokia. The warranty period for the Carry cases is three (3) months from the date of purchase or five (5) months from the date of wholesale shipment from Nokia.

During the warranty period, Nokia will, at its option, repair or replace the defective product free of charge. Replacement Product may be either new or remanufactured or refurbished.

However, if Nokia determines that the warranty conditions cannot be applied, the purchaser will be billed for the repair and shipping.

EXCEPTIONS

This warranty is subject to the following exceptions:

- 1 Mobile or fixed installation, which is not in accordance with the installation instructions, published by Nokia, will void the warranty. Damage caused by a repair or an attempt to repair by other than a service centre authorized by Nokia will void the warranty;
- 2 This warranty covers normal consumer use and does not cover defects or damage to any product which, in the sole opinion of Nokia, has been subject to: improper storage, exposure to moisture or dampness, exposure to fire, sand, dirt, windstorm, lightning, or earthquake; to theft, battery leakage, unauthorized modification, misuse, neglect, abuse, misapplication, accident, alteration, improper installation, maladjustment of consumer controls, or abnormal operating conditions, or which has been attributable to acts of God;
- 3 Fuses are not covered by the warranty;
- 4 This warranty does not cover defects or damages caused by a product which is not approved by Nokia to be connected to its wireless phone;

- 5 This warranty does not cover defects or damages caused by improper or defective function of the carrier system or by inadequate signal reception by the antenna;
- 6 Removal and reinstallation costs are not covered by this warranty;
- 7 This warranty is applicable only to products bought through Nokia Products Ltd. in Ajax, Ontario, Canada, and sold either in Canada or Bermuda.
- 8 Removal, alteration, or defacing of the Serial Number Plate, or the accessory Date Code Labels will void the warranty.

In no event shall Nokia be liable for incidental, special, or consequential damages, direct or indirect, loss of unanticipated benefits or profits, loss of use of its wireless telephone, resulting from the use of its wireless phone, or its enhancements, or arising from any breach of this warranty.

CLAIM PROCEDURE

In order to obtain warranty performance, return the defective unit to the Nokia Service Centre with transportation charges prepaid (Shipping of the repaired unit may be paid by Nokia, in which case Nokia shall have risk of loss or damage during this shipment).

The proof of date of purchase will be required before in-warranty service is rendered. Maintenance and service may be obtained in any authorized service centre in Canada.

EXTENSION OF WARRANTY PERIOD

When a repair is made, an extra 90-day service warranty is given to the labour and parts of the repair concerned. If replacement of a faulty unit is applied, instead of repairing, this 90-day service warranty is applied to the replaced unit.

Besides this 90-day service warranty, the warranty repairs or replacements do not affect the original warranty conditions, which are determined by the date of purchase.

THE FOREGOING WARRANTY IS THE PURCHASER'S SOLE AND EXCLUSIVE REMEDY AND IS IN LIEU OF ALL OTHER WARRANTIES, EXPRESSED OR IMPLIED, INCLUDING BUT NOT LIMITED TO ANY IMPLIED WARRANTY OR MERCHANTABILITY OR FITNESS FOR A PARTICULAR PURPOSE OR USE.

Some provinces do not allow limitations on how long an implied warranty lasts, so the above limitations may not apply to you.

FOR WARRANTY SERVICE LOCATIONS, CONTACT YOUR SERVICE PROVIDER/
RETAILER/DEALER OR DIRECTLY TO:

NOKIA PRODUCTS LIMITED

601 Westney Road South

Ajax, Ontario L1S 4N7

Tel: 905-427-1373

1-888-226-6542

Website: **www.nokia.ca**

For products being returned to Nokia or its authorized service centres, the service provider/retailer/dealer shall prepay shipping charges, taxes, duties, insurance. Nokia shall have no risk for loss or damage during this shipment.

NOTE: As warranty is automatically registered, no further action is required by the consumer.

Index

A

accessibility

- loopset 15
- web site 15

accessories

- boom headset (HDB-5) 85
- car kit (PPH-1) 87
- carry case (CSM-6) 88
- charger (ACP-12) 83
- charger (ACP-7) 82
- charger (ACP-8) 83
- charger (LCH-9) 83
- headset (HDC-5) 84
- headset (HDE-2) 84
- mobile holder (MBC-6) 86
- reference information 81
- safety information 80
- settings 49
- spare battery charger (DDC-1) 84

accessory

- TTY adapter 86

active call options 53

alarm clock 68

- phone off 68
- set 68
- snooze 68
- turn off 69

analog selection 64

antenna

- contact 9
- location 9
- performance 9
- proper position 9

automatic redial 59

B

back cover

- attaching 11
- removing 11

battery

- charging 12
- charging time 81
- important information 12
- initial charging 12
- install 10
- prolong life 13
- reference information 80
- remove 11
- standby time 81
- talk time 81

business cards 70

- delete 71
- receive 71
- save 71
- send 70

C

calculator 69

call duration

- viewing 36

call forwarding 56

- activate 57
- feature codes 56

call log

- about 34
- clear lists 35
- dialed calls 35
- missed calls 35
- options 34
- received calls 35

call timers 36

- clear timers 36
- current call timer 36

call waiting 57
activate 57
answer 57
feature code 57
manage calls 57
storing the feature code 57

calls
answer 18
automatic redial 59
conference 54
duration of 36
end 18
forward 56
make 17
redial last 18
silence 18
speed dialing 60
touch tones 60

car charger 83

car kit 87
automatic answer 50
default profile 50
set the lights 50

carry case 88

change
1-touch dialing numbers 60
contact list view 33
earpiece volume 18
letter case 26
message alert tone 48
profile name 49
ringing tone 47
ringing volume 48
security code 66
time format 51

charge the battery 12

charger
ACP-12 83
ACP-7 82
ACP-8 83
connecting 12
information 80

clear call lists 35

clock 51
alarm 68
automatic update 52
set the time 51
show/hide 52
time format 51

color covers 88

conference calls 54

contact list
delete entries 32
enter e-mail addresses 31
memory status 33
menu 24
menu options 24
new entry 31
quick access 18
scrolling view 33

contact Nokia 14

cover
attaching 11
removing 11

currency conversion 69

D

delete
call lists 35
contact list entries 32
messages from folders 40
text messages 42

dialed calls

deleting 35

viewing 35

digital selection 64

display language 51

E

e-mail messages 44

emergency calls

making 78

things to remember 78

with keypad locked 65

entering

e-mail addresses 31

names and numbers 30

text 25

F

folders

about 40

archive 40

delete messages from 40

inbox 40

outbox 40

four-way scrolling 27

G

games 72

Pairs II 73

Snake II 73

Space Impact 73

H

headset

connect 13

HDB-5 85

HDC-5 84

HDE-2 84

make and answer calls 13

hearing impaired solutions 15

help text 20

I

icons 20

illustrated view

antenna 9

battery install 10

battery removal 11

connect the charger 12

headset connection 13

phone 9

power key 17

in-call options 53

in-phone help 20

K

Keyguard 65

keypad

illustrated view 9

L

label 14

language setting 51

letters

uppercase and lowercase 26

lithium ion battery 82

lock/unlock the keypad 65

loopset 15

how it works 15

set for use 50

M

memory

contact list 33

text message 42

menu shortcuts

about 21

list of 22

menu tips 21

menus 21

messages

alert tone 48

check voice mail 37

e-mail 44

picture 43

read 41

text 40

text entry 25

write and send 41

missed calls

deleting 35

viewing 35

mobile holder 86

N

network search 63

network services 9

Nokia

accessories 81

customer care center 14

O

one-touch dialing 59

P

personalization 46

phone

illustrated 4

menus 21

switch on/off 17

picture messages 43

power 17

predictive text 27

turn off 28

turn on 28

profiles

accessory settings 49

customize 47

selecting 46

punctuation 27

R

received calls

deleting 35

viewing 35

reference information 74

ringing

options 47

tone 47

volume 48

ringing tones

change 47

S

save

e-mail addresses 31

names and numbers 30

text messages 40

voice mailbox number 37

search for network 63

security code 66

service provider

signing up 9

special characters

available 27

four-way scrolling 27

standby time 81

start screen 19

strings, touch tone 61

symbols 27

T

talk time 81

text clues 6

text messages 40

length 38

recipients 38

time 51

automatic update 52

select the format 51

set the clock 51

timers

check 36

clear 36

current call 36

touch tones

length 61

manual 61

sending 62

setting 60

storing 61

storing with numbers 62

troubleshooting 90

TTY 15

TTY adapter 86

TTY communication 86

turn the phone on/off 17

U

unlock the keypad 65

user guide

updates 6

user guide conventions 6

V

vibrating alert 48

view

call duration 36

clock on start screen 52

dialed calls 35

missed calls 35

picture messages 44

received calls 35

received messages 41

special characters 27

voice mail 37

listen to messages 38

messages 37

save number 37

volume

earpiece 18

keypad tones 49

ringing 48

W

warning tones 49

web sites

accessibility information 15

write and send a message 41

X

Xpress-on color covers 88