

# ZENOAH<sup>®</sup>

## ENGINE INSTRUCTION MANUAL

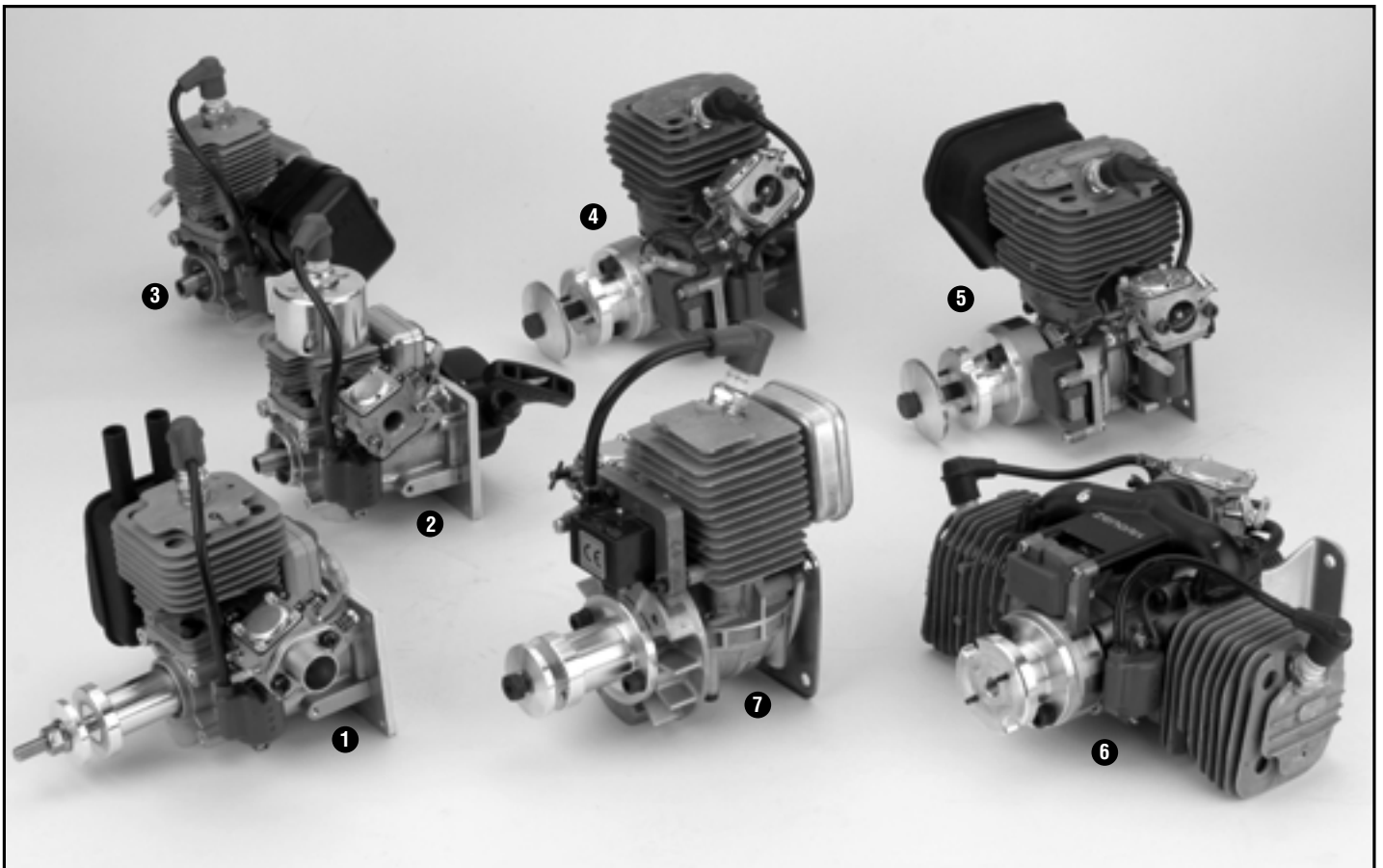

- G26 Air** ①
- G26/23I Marine** ②
- G23I Heli** ③
- G38** ④
- G62** ⑤
- GT80 Twin** ⑥
- G45** ⑦

# Table of Contents

---

- Introduction ..... 3
- Safety Instructions ..... 3
- Support Equipment ..... 4
- Mounting the Engine ..... 5
- Operation ..... 5
  - Break-In ..... 5
  - Starting the Engine-Aircraft ..... 5
  - Starting the Engine-Heli & Boat ..... 6
  - Stopping the Engine ..... 6
  - Carburetor Adjustment ..... 6
- Engine Care and Maintenance ..... 7
  - Recommendations ..... 7
  - Servicing the Engine ..... 7
  - Disassembly ..... 7
  - Assembly ..... 8
- Troubleshooting Guide for Gasoline Engines ..... 8
- Propeller Chart ..... 10
- Engine Specifications ..... 11
- Exploded Illustration ..... 12
  - G26/G231 ..... 12
  - G38 ..... 13
  - G45 ..... 14
  - G62 ..... 15
  - GT80 ..... 16
- Warranty Information ..... 17
  - Warranty Repairs ..... 17
  - Non-Warranty Repairs ..... 17
  - Registration Form ..... 18

# Very Important

---

**FAILURE TO READ AND FOLLOW THESE INSTRUCTIONS BEFORE YOU PROCEED MAY RESULT IN ENGINE DAMAGE AND THE VOIDING OF YOUR WARRANTY!**

## Introduction

---

Congratulations on purchasing a Zenoah® engine. Cared for properly, these high-quality, finely crafted engines will offer many years of reliability.

This instruction manual has been developed to ensure optimum performance from the Zenoah engine you have purchased. It's important that the instructions are read thoroughly prior to mounting and running the engine.

## Safety Instructions

---

This manual describes the engine's features and functions. For specific information on mounting, see the instruction manual included with the model airplane, helicopter or boat in which you intend to install the engine.

This model engine will give you considerable pleasure, satisfaction and performance if you strictly follow these safety instructions and take heed of the warnings as to the engine's safe and proper use. This engine has more than enough power to cause harm if misused or if the safety precautions are not observed.

### Always

1. Use genuine parts for replacement.
2. Check the propeller, rotor (helicopter) or screw propeller (boat) prior to each time the engine is used. If nicked, scratched, cracked or damaged in any way, replace it with a new one.
3. Use the correct size and pitch of propeller for your engine; refer to the propeller chart in this manual.
4. It is extremely important to balance the propeller prior to installation of the engine. Failure to do so may cause damage to the Zenoah engine and/or the airframe. Securely tighten the propeller nut against the washer and propeller.
5. Inspect the tightness of the propeller nut prior to each flight.
6. Keep your face and body away from the path of the propeller blades when starting or running your engine.

7. Use a thickly padded glove when hand starting the engine.

8. Make all carburetor adjustments from behind the propeller.

9. To stop the engine, the black lead wire from the coil should be grounded to the engine body, or use the throttle linkage to shut off the air by closing the throttle valve completely.

**DO NOT USE HANDS, FINGERS OR ANY OTHER PART OF THE BODY TO STOP THE PROPELLER. DO NOT THROW ANY OBJECT INTO A PROPELLER TO STOP IT!**

10. Ensure that all spectators, especially children, are at least 20 feet away when you start running the engine.

11. Make sure your fuel is kept in a safe place well away from sparks, heat or anything that could ignite the fuel.

### Recommendations

1. Use safety glasses or goggles when starting and running your engine.

2. Do not run the engine in the vicinity of loose gravel or sand. The propeller may throw such materials into your eyes. The engine could also ingest these harmful materials.

3. Avoid loose clothing when operating your model engine, as it could become entangled in the propeller, creating the possibility of bodily harm. All loose objects (screwdrivers, pencils, nickel cadmium glow drivers, etc.) should be removed from your pockets so that they do not fall into the propeller.

# Safety Instructions (continued)

---

## Caution

1. Model engines get very hot while running. Do not attempt to handle them until they have cooled.
2. Always run your model engines in a well-ventilated area. Similar to automotive engines, model engines produce harmful carbon monoxide fumes.
3. Never modify the flywheel.
4. Check the flywheel. If it's damaged, replace it with a new one.
5. When mixing the fuel or operating the engine, do so in a well-ventilated area.
6. Remember that model engines produce a substantial amount of power, more than enough to seriously injure people and/or do considerable damage to property. Always use common sense, skill and constant observation of safety precautions.

## Disassembly

The Zenoah engine can be disassembled or reassembled without any specific difficulties. Refer to the Engine Maintenance Section for specific instructions on these procedures. If you need service to your Zenoah engine, please send your engine to the authorized service center at the following address:

Horizon Hobby, Inc.  
Attention: Zenoah Service  
4105 Fieldstone Road  
Champaign, IL 61822  
Phone: (217) 355-9511

## Engine Parts Identification

It's important to be able to identify the parts of your Zenoah engines. Attached you will find an exploded view of Zenoah engines, as well as a chart including part numbers and descriptions. This will assist you in easily and rapidly identifying the respective parts of your Zenoah engine.

# Support Equipment

---

The following items, which are not included with your Zenoah engine, are necessary in order to operate the model engine.

**Fuel**—Mix gasoline and 2-stroke oil at a mixing ratio of 25-40:1.

**Note:** Be sure to use a gasoline-resistant fuel tubing (do not use any silicone rubber tube). Never use any alcohol fuel or alcohol-added fuel as this will damage the rubber part of the carburetor.

**Propeller**—Refer to the Propeller Selection Chart located on Page 8 to determine the best initial propeller for your particular application.

**Manual or Electric Starter**—For manual starts, a chicken stick is highly recommended. **Never** use your fingers to start any model engine as you could get injured. If you must hand start a gasoline engine, be sure to protect your hand with a heavily padded glove. There are a variety of heavy-duty electric starters on the market that can be used.



Zenoah Oil  
ZEN20001

Zenoah Start Kit  
ZEN20002

# Mounting the Engine

Make sure the engine is mounted on the aircraft using aircraft grade plywood that's at least 6mm in thickness for the G26 engine, and 10mm in thickness for the G38 through GT80 twin, or a mount of equivalent strength. Make sure it's firmly mounted with 4 bolts.



1. Be sure to set flat washers or a metal plate on the reverse side of the mount to prevent the bolts from sinking into the mount. Periodically check the engine mount for loose bolts.
2. Since the engine is equipped with a floatless carburetor with a diaphragm pump, the direction of the cylinder and position of the fuel tank can be freely selected.
3. If the engine is mounted on a shock (rubber) mount placed between the engine and the firewall for anti-vibration, check the hardness of the rubber, making sure it's not too soft, in order to avoid excessive vibration during engine operating rpms. It's suggested you note carefully if the engine is vibrating at idle as excessive vibration can result in erratic engine operation due to overflow at the carburetor.
4. It is suggested you coat the bolts for the muffler with threadlock when mounting the muffler to the engine.

# Operation

## Break-In

No specific break-in is required. The engine is gradually broken-in as it is used, and the output power increases gradually as the engine breaks in.

## Starting the Engine—Aircraft

Before attempting to start the engine, be sure to read through all the steps for starting the engine as outlined below:

Zenoah engines are equipped with the ultra compact C.D.I. type flywheel magneto ignition system and should be started according to the following procedure:

**Note:** The magneto system is timed in such a way that when the compression stroke starts (refer to Figure 1-A) sparks are never produced on the spark plug, no matter how fast the propeller is flipped. The correct starting procedure is to quickly flip the propeller when the edge of the magnet on the rotor is approaching the coil (Figure 1-B). This means that the propeller should be quickly flipped at about 90 degrees in crank angle before the compression stroke is about to start.

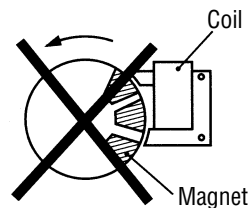

Fig 1-A

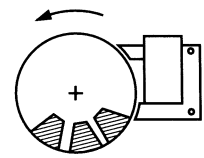

Fig 1-B

1. Make sure the spark (glow) plug(s) are installed and tightened. Check the condition of the plug cap for cracks or breaks.
2. Be sure the propeller is properly secured.
3. Make sure the fuel tank line(s) are properly connected. The main line should be connected to the carburetor spray bar.
4. Be certain the mufflers are installed properly.
5. Fill the fuel tank.
6. Choke the engine and turn the propeller through a few times until the fuel appears at the carburetor.
7. Set the throttle valve at the idle position or at the position slightly open from idle.

# Operation (continued)

8. Quickly flip the propeller in a counterclockwise direction according to the procedure described in the note above.
9. The engine should start after a few flips of the propeller.
10. Be sure to open the choke when the initial firing of the engine is heard.
11. When the choke is opened, be sure to close the throttle valve to a position near the idle position before the next flipping of the propeller is attempted.

**CAUTION:** If the engine is started when the throttle is wide open, a great thrusting force will be generated, which can be very dangerous.

12. If you do not use a chicken stick to start the engine, be sure to wear a thick glove when flipping the propeller and use all fingers, except the thumb, for the flipping operation.
13. Do not over-rev the engine. These engines are designed to develop maximum output with the standard muffler and the recommended propeller size. Please refer to the propeller chart on page 10 to confirm the proper propeller for the applicable Zenoah engine.

## Starting the Engine— Helicopter and Boat

1. Fill the tank with fuel.
2. Push the priming bulb located on the carburetor until fuel appears in the priming bulb (for helicopter).
3. Choke the engine and open the throttle valve approximately 1/3–1/2 of the full open position.
4. Quickly pull the starter cord until the initial firing of the engine is heard.
5. When the initial firing is heard, open the choke, set the throttle valve at the idle position or at the position slightly open from the idle position and quickly pull the starter cord a few more times until the engine starts.
6. For helicopter operation, you should adjust the rotor-pitch to obtain a 9,000 to 10,000 rpm of the engine at full throttle operation.

## Stopping the Engine

The ability to shut down the engine in an emergency is extremely important. For stopping the engine, the black lead wire from the coil should be grounded to the engine

body, or the throttle valve should be closed completely. Installation of a “stop” or “kill” switch is recommended.

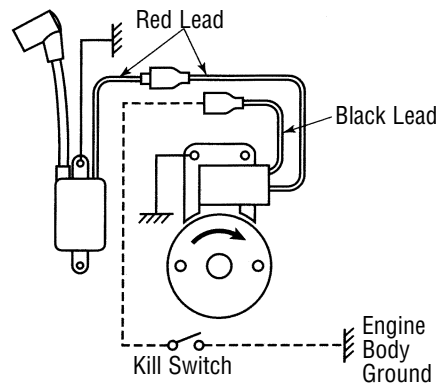

Refer to the example shown in the following diagram.

## Carburetor Adjustment

The carburetor is provided with three adjustment screws, which are factory set to the best (approximate) positions. They may need minor adjustment, depending upon the temperature, humidity, atmospheric pressure (altitude), etc., of the area where the engine is being used.

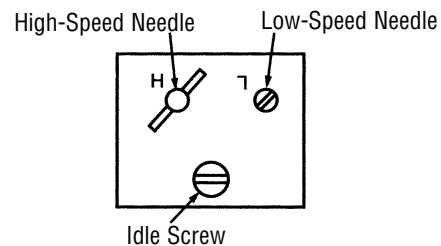

1. Start the engine without making any adjustments.
2. Make adjustments only when the engine shows signs of inefficient operation.
3. Standard settings of each needle is as follows:
  - a. Low-Speed Needle:  $1\frac{1}{8}$  plus/minus  $\frac{1}{4}$
  - b. High-Speed Needle:  $1\frac{3}{8}$  plus/minus  $\frac{1}{4}$

**Idle Screw:** Turning this screw clockwise increases the idling RPM. Turning it counterclockwise decreases the idling RPM.

**Low-Speed Needle:** This is the fuel adjust screw (not the air screw). Turning this needle clockwise makes the gas mixture leaner, and turning it counterclockwise makes it richer.

# Operation (continued)

---

**High-Speed Needle:** Turning this needle clockwise makes the gas mixture leaner, and turning it counter-clockwise makes it richer. Set this needle at a position which is 1/4 open from the maximum rpm position while the aircraft is on the ground.

**Note:** Do not tighten the high and low speed needles too tightly.

When the engine has just started and is not warm enough, there may be insufficient acceleration and the engine may die. Be sure to allow the engine to warm up at idle for a few minutes before conducting normal operation.

## Engine Care and Maintenance

---

### Recommendations

To extend the life of your Zenoah® engine, the following is recommended:

1. Use a Zenoah quality 2-stroke oil mixed at 32 to 1.
2. Use the recommended spark plugs.
3. Use the proper propeller size and balance the propeller prior to use.
4. Always adjust the engine to a slightly rich setting.
5. For long-term storage, make sure there is no fuel left in the tank or the engine. Remove the spark plug(s) and apply several drops of high-quality oil (e.g., Marvel Air Tool Oil) to the top of the engine and into the spark plug hole. Rotate the crankshaft several times. Store the engine in the box it came in or on the airplane with the nose down in order to keep oil in the bearings.

### Servicing the Engine

#### Required Tools

- Regular screwdriver
- Phillips screwdriver
- Hexagonal wrench (4mm/5/32")
- Open wrench (19mm/3/4")
- Plastic hammer
- Thickness gauge
- Tapered round rod
- Liquid gasket (Permatex or equivalent)
- Thread lock (Blue Threadlock Z-42 or equivalent)
- Lithium grease

- Engine oil
- Washing gasoline
- Brush
- Scraper
- Cloth

The engine can be disassembled or reassembled without any specific difficulties, but note the following:

For disassembling, the special tools shown in the parts list are required (stopper, puller assembly), in addition to general tools. Be sure to use a new gasket when the crankcase and cylinder have been disassembled.

**Note:** Because the crankshaft is of the assembly type, do not disassemble, hit or twist its end.

### Disassembly

1. Dismount the engine from the model.
2. Remove the carburetor and insulator carefully without damaging the gasket.
3. Remove the muffler.
4. Remove the spark plug and ignition module.
5. Remove the propeller hub.
6. Remove the rotor (flywheel). If it cannot be detached, use a plastic hammer and hit the part lightly.
  - a. Screw the stopper in place of the spark plug, then turn the rotor counterclockwise until the piston touches the stopper. Take care as it can cause damage to the piston or connecting rod if the stopper is not screwed in to the bottom.
  - b. Loosen and remove the rotor securing nut.

# Engine Care and Maintenance (continued)

---

- c. Remove the rotor by using the puller. Do not hit the crankshaft with the plastic hammer, as this can increase the runout of the shaft.
7. Remove the mounting plate.
8. Remove the four bolts from the crankcase.
9. Tap around the case fitting side gently with the plastic hammer and slowly separate the crankcase from the cylinder block.
10. Pull out the crankshaft with the piston, bearings, and other parts attached.
11. Remove the Woodruff key from the crankshaft.
12. Remove the oil seal, snap ring and bearings.
13. Remove the circlip and pull out the piston pin.
14. Remove the thrust washers and needle bearing from the smaller end of the con rod (G38).
15. Remove the piston ring.
16. Wash each part. Check for abrasion and damage, and replace any part that is defective.
7. Wipe the contact surfaces of the cylinder block and crankcase, and apply liquid gasket (Permatex or equivalent).
8. Put the piston in the cylinder, with the piston's arrow facing in the exhaust port direction. Set the crankshaft to the cylinder block. Then, fit the oil seal to the cylinder block. The snap ring joint should be set vertically to the cylinder.
9. Fit the crankcase to the cylinder block and tighten the bolts.
10. Check that the crankshaft can be smoothly turned by hand.
11. Put back the Woodruff key.
12. Replace the rotor (flywheel), fitting it to the Woodruff key. Tighten the hub nut after having applied threadlock (Blue Threadlock Z-42 or equivalent) to the threads.
13. Apply threadlock (Blue Threadlock Z-42) to the muffler bolts and mount the muffler.
14. Apply threadlock (Blue Threadlock Z-42) to the ignition module set screws and fix the coil temporarily.
15. Set the rotor (flywheel) so that the magnet is located on the opposite side of the module (G-38). Place a thickness gauge between the core of the module and rotor (flywheel) and adjust the clearance to 0.25 ^ 0.35 mm (0.01 ^ 0.014 in). Then tighten the set screws after having applied threadlock (Blue Threadlock Z-42) to them.

## Assembly (G38)

1. Apply engine oil (SAE #30) to the inside of the cylinder and to the needle bearings on the larger end of the connecting rod.
  2. Fit the piston ring to the piston.
  3. Mount the needle bearing and thrust washer (with its oil slot facing inside) to the smaller end of the connecting rod and apply engine oil (SAE #30).
  4. With the arrow on the top of the piston facing the straight side (opposite side to the propeller) of the crankshaft, fit the piston to the top of the connecting rod and insert the piston pin with its blank end to the exhaust port side.
  5. Fit the circlip.
  6. Fit the bearings, snap ring and oil seal to the crankshaft. (Apply lithium grease to the lip area of the oil seal and fit it, paying attention to its direction.)
  16. Using a new gasket, fix the insulator with screws to which threadlock (Blue Threadlock Z-42) has been applied.
  17. Using a new gasket, mount the carburetor with screws, paying attention to its mounting direction.
  18. Tighten the mounting plate, using screws with threadlock (Blue Threadlock Z-42) applied.
  19. Install the spark plug.
- Note:** Disassembly and assembly steps were written using a G38 engine as an example, but they apply to all engines.

---

# Troubleshooting Guide for Gasoline Engines

---

Generally speaking, there are very few things that will keep today's modern engines from starting. Use good quality "fresh" fuel and make sure that good plugs are

installed. Should the engine fail to start after these items are verified, refer to the charts on the following page.



# Troubleshooting Guide for Gasoline Engines

## a) The engine does not start.

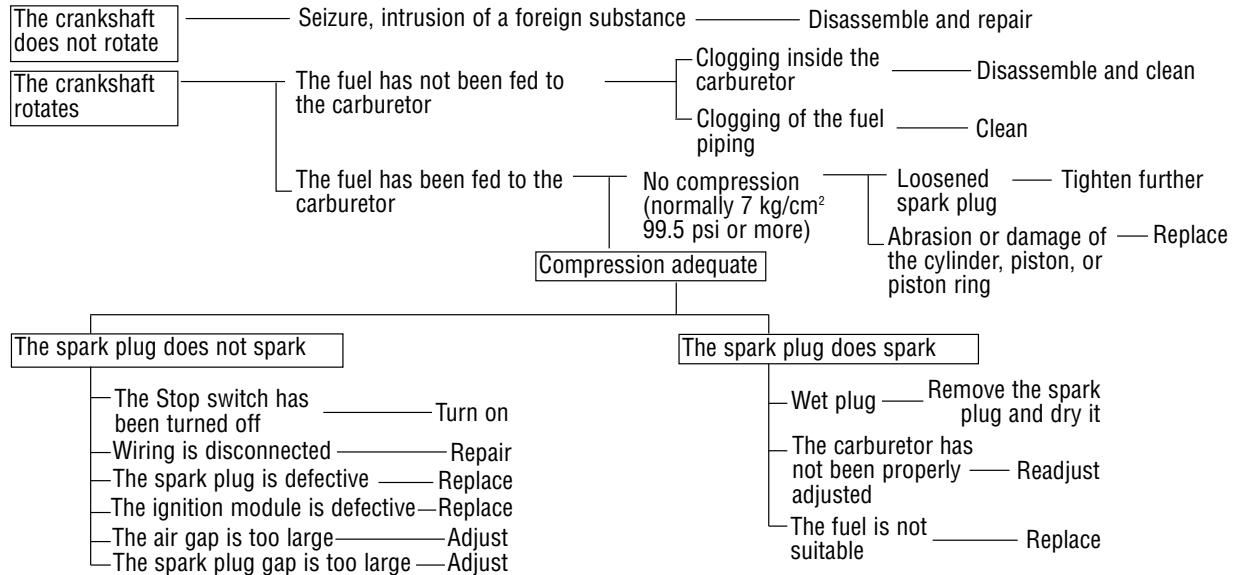

## b) The engine stops by itself

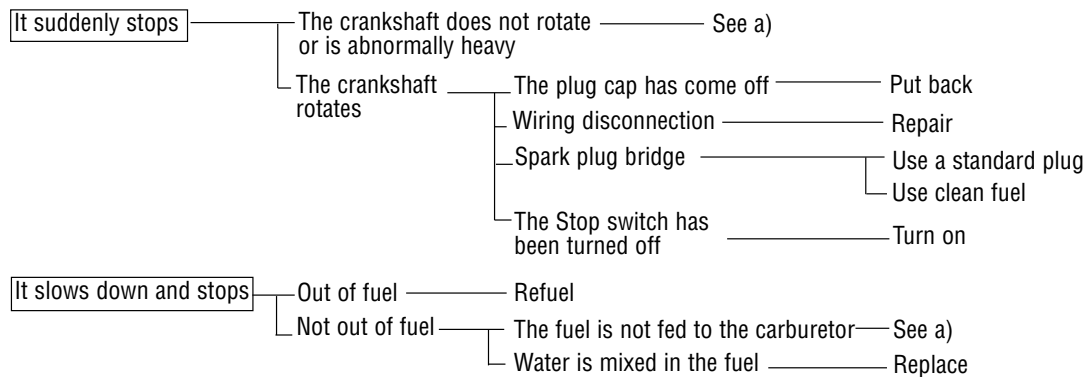

## c) Lower power output

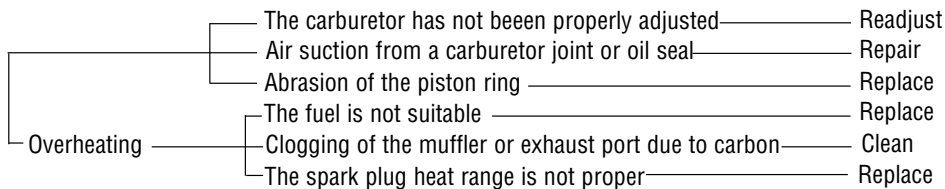

## d) The engine does not stop

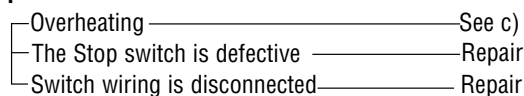

# Troubleshooting Guide for Gasoline Engines

(continued)

---

In the event that none of the above procedures results in the engine running properly, contact our service department for suggestions at:

Horizon Hobby, Inc.  
4105 Fieldstone Road  
Champaign, IL 61822  
Phone: 217-355-9511 (M-F 8:00–5:00 CST)

## Propeller Chart

---

This chart enables you to select the best propeller for initial set-up of your Zenoah® engine.

**Note:** All recommendations are based on engines using APC brand props.

Remember, it's imperative to balance each propeller prior to installation onto your Zenoah engine. Failure to do so may cause unwanted vibration in your aircraft.

ENGINE	PROPELLER
<b>G26A</b>	16x8 @ 8,700
<b>G231 Heli</b>	Adjust pitch of rotor to obtain 9,000–10,000 rpm of the engine at full throttle
<b>G26 Marine</b> <b>G231 Marine</b>	Diameter=65–75mm Pitch ratio 1.9–1.4mm*
<b>G38 Gas</b>	18x10 @ 7,300
<b>G45 Gas</b>	20x10 @ 7,200
<b>G62 Gas</b>	22x10 @ 7,200
<b>GT80 Gas</b>	22x12 @ 7,200 24x10 @ 7,200

# Engine Specifications

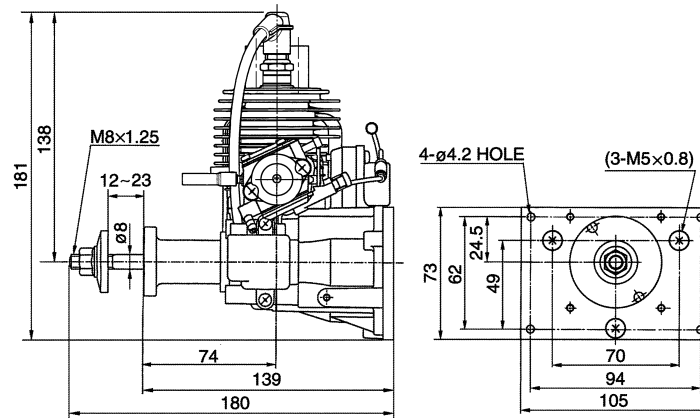

## OUTSIDE DIMENSIONS (MM)

Items	Length	Width	Height	Operating RPM	Optional Mufflers
G26A	139mm	105mm	181mm	2,000–10,000	BIS07123
G26M	139mm	105mm	181mm	2,000–10,000	—
G231 HELI	142mm	105mm	181mm	3,000–11,000	—
G231 MARINE	142mm	105mm	181mm	3,500–15,000	—
G38	170mm	130mm	215mm	2,000–9,000	BIS07138
G45	152mm	130mm	185mm	2,000–10,000	BIS07145
G62	162.5mm	140mm	185mm	2,000–10,000	BIS07163
GT80	191.5mm	257mm	190mm	1800–10,000	BIS07445/6

## SPECIFICATIONS

	Displacement (cu in)	Bore (in)	Stroke (in)	Weight (oz)	K (ISO)	HP (H/M)	Carb (Walboro)
G26A/M	1.55	1.41	1.1	54	M8x1.25/6x1	2.4	WT645/WT644
G231M/H	1.4	1.3	1.1	54	M8x1.25	2.2	WT644/WT643
G38	2.3	1.5	1.3	67	M10x1.25	2.2	WT338/WTA-6A
G45	2.74	1.69	1.22	74	8x1	3.3	HDA-48D
G62	3.8	1.9	1.4	73	10x1	4.75	HDA-48D
GT80	4.8	1.59x2	1.22x2	126	—	6	WJ-64

\* w/spring starter

# Exploded Illustration

## G26/G231

Index No.	Part No.	Description	Q'ty per unit			
			G260 PU	G260 PUM	G231 PUH	G2301 PUM
1-1	ZEN2601	CYLINDER	1	-	-	-
1-2	ZEN2301RC	CYLINDER	-	-	1	-
2-1	ZEN2601M	CYLINDER	-	1	-	-
2-2	ZEN23102M	CYLINDER	-	-	-	1
3	ZEN23103M	JACKET	-	1	-	1
4	ZEN2304M	JOINT	-	2	-	2
5	ZEN23105M	O-RING 3X40	-	1	-	1
6	ZEN23106M	O-RING 1.5X15.5	-	1	-	1
7	ZEN23107M	BOLT M3X8	-	2	-	2
8	ZEN23108	GASKET, CYLINDER	1	1	1	1
9	ZEN2309	BOLT M5X20	6	6	6	6
10	ZEN23110	GASKET, INSULATOR	1	1	1	1
11	ZEN23111	INSULATOR	1	1	1	1
12	ZEN23112	GASKET, CARBURETOR	1	1	2	1
	ZEN23114	CRANKCASE, COMP.	1	1	1	1
13		CRANKCASE, (R)	1	1	1	1
14		CRANKCASE, (F)	1	1	1	1
15	ZEN6213	PIN	3	3	3	3
16	ZEN23116	GASKET	1	1	1	1
17	ZEN2317	SEAL 12X22X7	1	1	1	1
18	ZEN2318	BEARING	2	2	2	2
19	ZEN2319	SNAPRING	1	1	1	1
20	ZEN2320	BEARING	1	-	1	-
21	ZEN2321M	SEAL 12X28X7	-	1	-	1
22	ZEN2322	BOLT M5X30	4	4	4	4
23-1	ZEN2623	PISTON	1	1	-	-
23-2	ZEN2320RC	PISTON	-	-	1	1
24-1	ZEN2624	RING	1	1	-	-
24-2	ZEN2321RC	RING	-	-	1	1
25-1	ZEN2625	PISTON RING	1	1	-	-
25-2	ZEN2325	PISTON RING	-	-	1	1
26	ZEN2326	SNAP RING	2	2	2	2
27	ZEN2327	BEARING	1	1	1	1
28	ZEN2328	WASHER	2	2	2	2
29	ZEN23129	CRANKSHAFT, COMP.	1	1	1	1
30	ZEN2330	MOUNT, PLATE	1	1	1	1
31	ZEN2331	SCREW M5X16	3	3	3	3
32	ZEN2332	NUT M8	1	-	-	-
33	ZEN2333M	PULLEY	-	1	1	1
34	ZEN2634	RECIL ASSY	-	1	1	1
35	ZEN2431	SCREW M4X14	-	4	4	4
36	ZEN6227	KEY	1	1	1	1
37	ZEN2337	SHIM	1	1	1	1
38-1	ZEN6236	COIL, (GREY)	1	-	-	-
38-2	ZEN2339M	COIL, (RED)	-	1	1	1
39	ZEN2354	ROTOR	1	1	1	1
40	ZEN6241	SCREW M4X22	2	2	2	2
41	ZEN2341	SCREW M4X14	2	2	2	2
42	ZEN2638	PLUG CAP	1	1	1	1
43	ZEN6239	SPRING	1	1	1	1
44	ZEN6237	COIL	1	1	1	1
45	ZEN26451	SPARK PLUG RZ7C	1	-	1	-
46	ZEN2648	SCREW M5X55	2	2	2	2
47	ZEN2647	SPACER 5X10X1.6	2	2	-	2
48	ZEN2649	AIR-FUNNEL	1	1	-	1
49	ZEN23150H	CLEANER ASSEMBLY	-	-	1	-
50	ZEN2650	TUBE	1	1	-	1

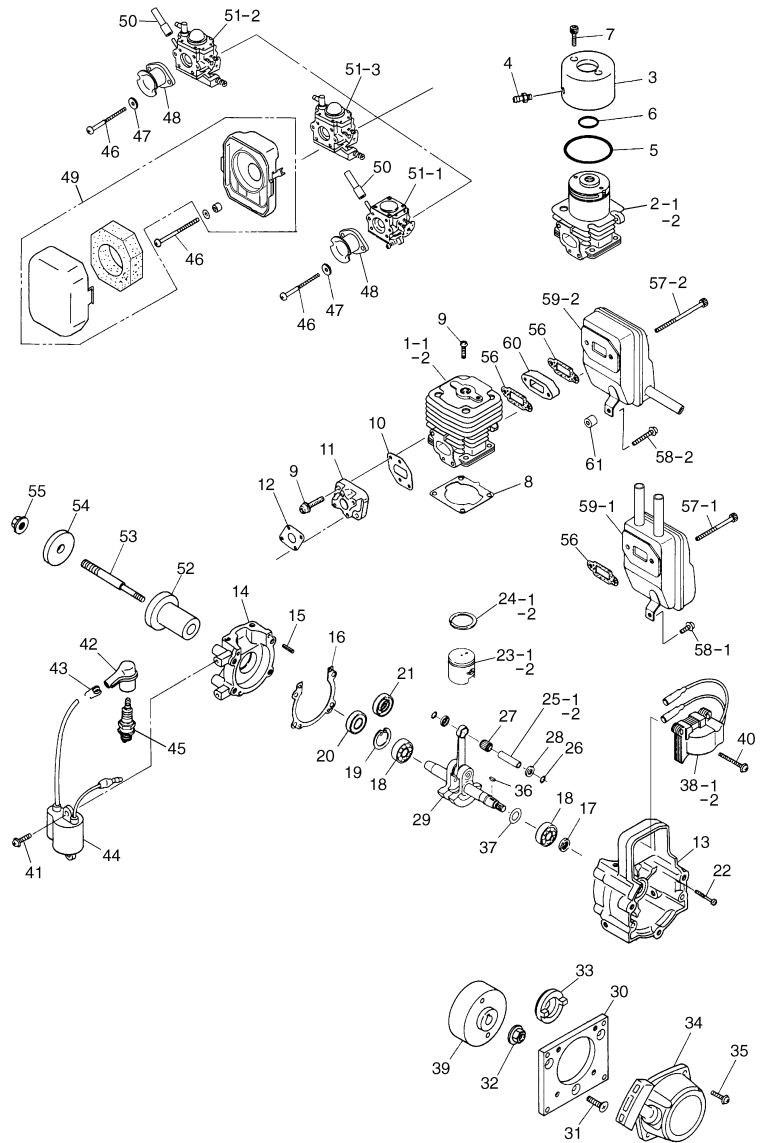

Index No.	Part No.	Description	Q'ty per unit			
			G260 PU	G260 PUM	G231 PUH	G2301 PUM
51-1	ZEN2651	CARBURETOR ASSY WT-645	1	-	-	-
51-2	ZEN23151	CARBURETOR ASSY WT-644	-	1	-	1
51-3	ZEN23152	CARBURETOR ASSY WT-643	-	-	1	-
52	ZEN2359	HUB	1	-	-	-
53	ZEN2360	STUD	1	-	-	-
54	ZEN2361	WASHER	1	-	-	-
55	ZEN2362	NUT M8	1	-	-	-
56	ZEN23156	GASKET, MUFFLER	1	-	2	-
57-1	ZEN2357	BOLT M5X50	2	-	-	-
57-2	ZEN2357H	BOLT M5X60	-	-	2	-
58-1	ZEN2358	SCREW M4X8	1	-	-	-
58-2	ZEN2358H/RC	SCREW M4X16	-	-	1	-
59-1	ZEN2655	MUFFLER	1	-	-	-
59-2	ZEN2355	MUFFLER	-	-	1	-
60	ZEN2366	SPACER	-	-	1	-
61	ZEN2367	SPACER	-	-	1	-
62	ZEN23124RC	SOCKET	1	1	1	1

# Exploded Illustration

G38

(Standard Accessory for  
G380PU)

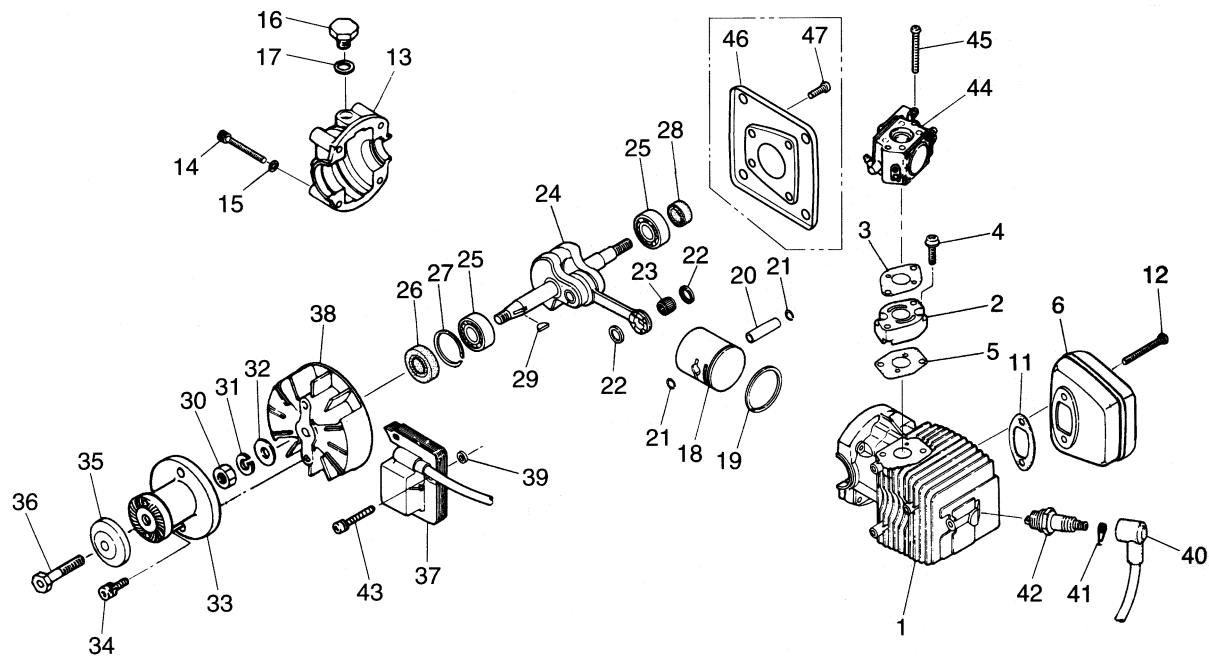

Index No.	Part No.	Description	Q'ty/unit
1	ZEN3801	CYLINDER	1
2	ZEN3802	INSULATOR	1
3	ZEN3803	CARB GASKET	1
4	ZEN3804	INSULATOR SCREW	2
5	ZEN3805	INSULATOR GASKET	1
6	ZEN3806	MUFFLER ASS'Y	1
11	ZEN3811	MUFFLER GASKET	1
12	ZEN3812	MUFFLER BOLT	2
13	ZEN3813	CRANKCASE	1
14	ZEN3814	CASE BOLT	4
15	ZEN3815	CASE WASHER	4
16	ZEN3816	CASE PLUG	1
17	ZEN3817	PLUG GASKET	1
18	ZEN3818	PISTON	1
19	ZEN3819	PISTON RING	1
20	ZEN3820	PISTON PIN	1

Index No.	Part No.	Description	Q'ty/unit
21	ZEN3821	PIN RETAINER	2
22	ZEN3822	CONROD SPACER	2
23	ZEN3823	CONROD BEARING	1
24	ZEN3824	CRANKSHAFT	1
25	ZEN3825	CRANKSHAFT BEARING	2
26	ZEN3826	FRONT OIL SEAL	1
27	ZEN3827	SNAP RING	1
28	ZEN3828	REAR OIL SEAL	1
29	ZEN3829	KEY	1
30	ZEN3830	ROTOR NUT	1
31	ZEN3831	LOCK WASHER	1
32	ZEN3832	ROTOR WASHER	1
33	ZEN3833	PROP HUB (NEW)	1
34	ZEN3834	HUB BOLT	2
35	ZEN3835	PROP WASHER (NEW)	1
36	ZEN3836	PROP BOLT (NEW)	2

Index No.	Part No.	Description	Q'ty/unit
37	ZEN3837	MODULE	1
38	ZEN3838	ROTOR (NEW)	1
39	ZEN3839	SPACER (MODULE)	3
40	ZEN6238	PLUG CAP (BLACK)	1
41	ZEN6239	CAP SPRING	1
42	ZEN6242	SPARK PLUG, C859	1
43	ZEN3843	MODULE BOLT	3
44-1	ZEN3844	CARB ASS'Y (HT-338) W/CHOKE	1
44-2	ZEN3850	CARB ASS'Y (WTA-6) W/O CHOKE	1
45	ZEN3845	CARB SCREW	2
46	ZEN3846	MOUNT	1
47	ZEN3847	MOUNTING BOLT	4
	ZEN3870	GASKET SET	1
	ZEN3871	SCREW/NUT SET	1

# Exploded Illustration

G45

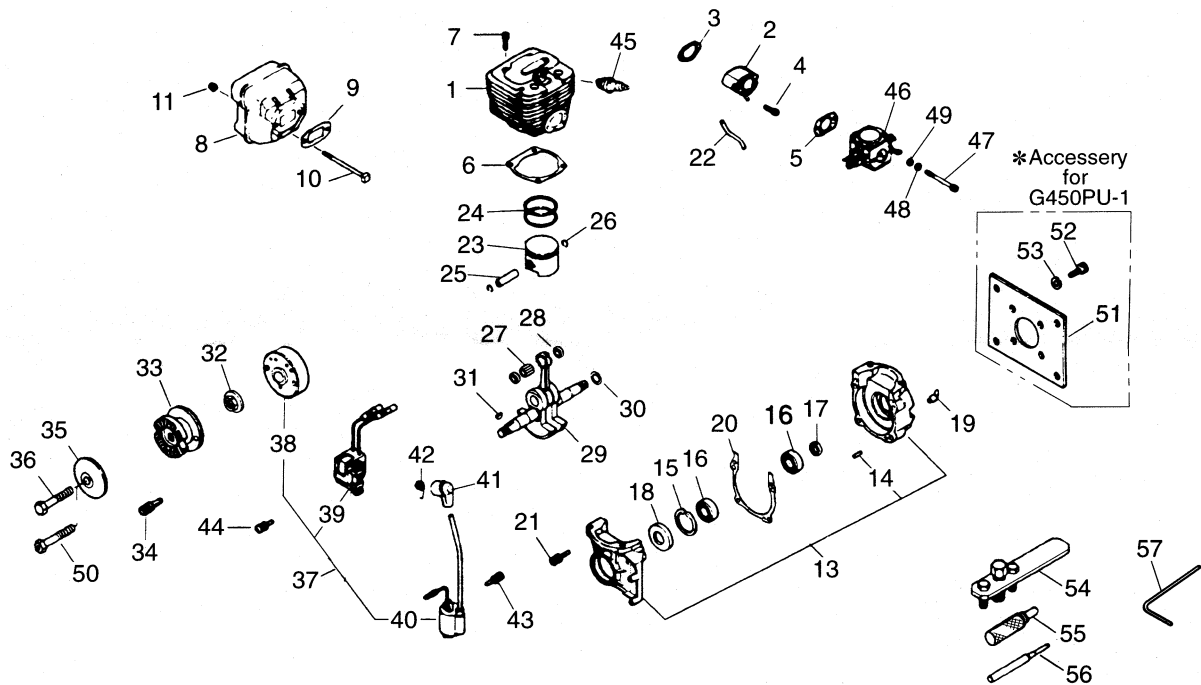

Index No.	Part No.	Description	Q'ty/unit	Index No.	Part No.	Description	Q'ty/unit	Index No.	Part No.	Description	Q'ty/unit
1	ZEN4501	CYLINDER	1	21	ZEN4504	BOLT	4	40	ZEN6237	IGNITION COIL	1
2	ZEN4502	INSULATOR	1	22	ZEN4522	PIPE	1	41	ZEN6238	PLUG CAP (BLACK)	1
3	ZEN4503	INSULATOR GASKET	1	23	ZEN4523	PISTON	1	42	ZEN6239	CAP SPRING	1
4	ZEN4504	BOLT	2	24	ZEN4524	PISTON RING	2	43	ZEN4543	SOURCE COIL SCREW	2
5	ZEN6204	CARBURETOR GASKET	1	25	ZEN4525	PISTON PIN	1	44	ZEN6241	COIL SCREW	2
6	ZEN4506	CYLINDER GASKET	1	26	ZEN6223	PIN RETAINER	2	45	ZEN6242	SPARK PLUG	1
7	ZEN4504	BOLT	4	27	ZEN6224	CONROD BEARING	1	46	ZEN6243	CARBURETOR ASS'Y	1
8	ZEN6207	MUFFLER	1	28	ZEN4528	WASHER	2	47	ZEN4547	BOLT	2
9	ZEN6208	MUFFLER GASKET	1	29	ZEN4529	CRANKSHAFT COMP.	1	48	ZEN6245	WASHER	2
10	ZEN6209	MUFFLER BOLT	2	30	ZEN6228	SHIM	0-2	49	ZEN6246	WASHER	2
11	ZEN6210	MUFFLER NUT	2	31	ZEN6227	KEY	1	50	ZEN6247	BOLT	1
13	ZEN4513	CRANKCASE COMP.	1	32	ZEN6229	FLYWHEEL NUT	1	51	ZEN6248	MOUNT	1
14	ZEN6213	CASE PIN	3	33	ZEN6230	PROP HUB	1	52	ZEN6249	BOLT } * for G450PU	4
15	ZEN6214	SNAP RING	1	34	ZEN6232	HUB BOLT	2	53	ZEN6250	WASHER	4
16	ZEN6215	BEARING	2	35	ZEN6233	WASHER	1	54	ZEN6251	PULLER ASS'Y	1
17	ZEN6216	REAR OIL SEAL	1	36	ZEN6234	PROP BOLT	1	55	ZEN6252	STOPPER (OPTIONAL)	1
18	ZEN6217	FRONT OIL SEAL	1	37	ZEN6257	MAGNETO ASS'Y	1	56	ZEN6253	GUIDE (OPTIONAL)	1
19	ZEN6276	ELBOW FUEL NIPPLE	1	38	ZEN6235	ROTOR	1	57	ZEN4557	WRENCH (OPTIONAL)	1
20	ZEN4520	CASE GASKET	1	39	ZEN6236	SOURCE COIL	1				

# Exploded Illustration

G62

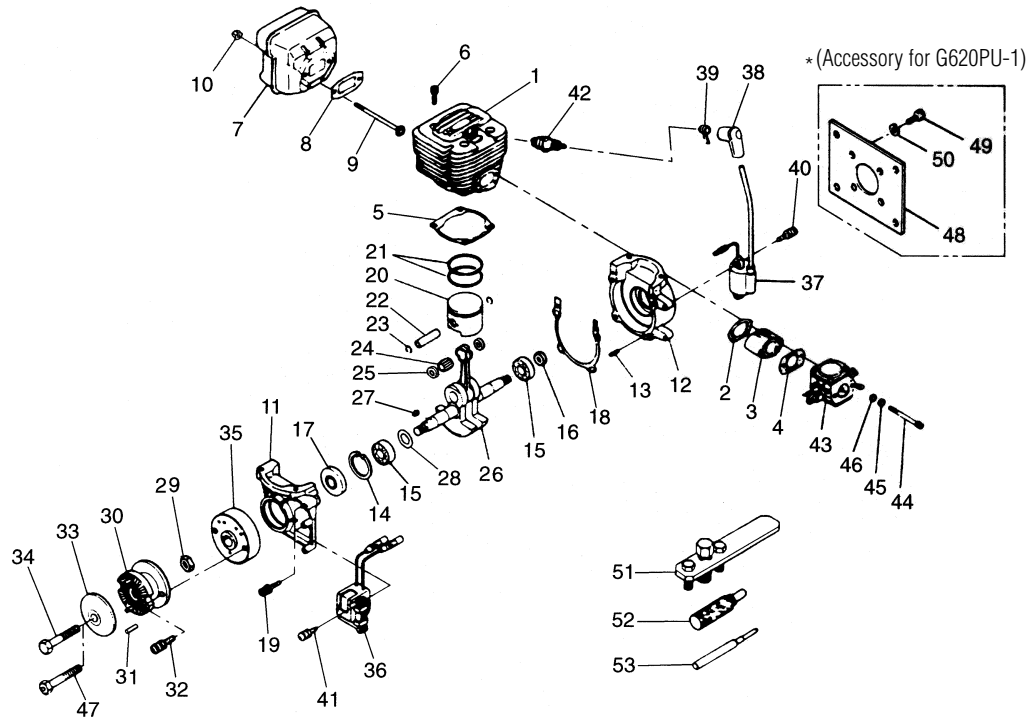

Index No.	Part No.	Description	Q'ty/unit	Index No.	Part No.	Description	Q'ty/unit	Index No.	Part No.	Description	Q'ty/unit
1	ZEN6201	CYLINDER	1	21	ZEN6221	PISTON RING	4	40	ZEN6240	IGNITION COIL SCREW	2
2	ZEN6202	INSULATOR GASKET	1	22	ZEN6222	PISTON PIN	1	41	ZEN6241	SOURCE COIL SCREW	2
3	ZEN6203	INSULATOR	1	23	ZEN6223	PIN RETAINER	1	42	ZEN6242	SPARK PLUG, C859	1
4	ZEN6204	CARBURETOR GASKET	1	24	ZEN6224	NEEDLE BEARING	2	43	ZEN6243	CARBURETOR ASS'Y	1
5	ZEN6205	CYLINDER BASE GASKET	1	25	ZEN6225	CONROD SPACER	1	44	ZEN6244	CARB MOUNT SCREW	2
6	ZEN2309	CYLINDER BOLT	4	26	ZEN6226	CRANKSHAFT COMP.	2	45	ZEN6245	CARB WASHER	2
7	ZEN6207	MUFFLER	1	27	ZEN6227	KEY	1	46	ZEN6246	WASHER	2
8	ZEN6208	MUFFLER GASKET	1	28	ZEN6228	SHIM	2	47	ZEN6247	TAP PROP BOLT	1
9	ZEN6209	MUFFLER BOLT	2	29	ZEN6229	FLYWHEEL NUT	1	48	ZEN6248	MOUNT	1
10	ZEN6210	MUFFLER NUT	2	30	ZEN6230	PROPELLER COMP. FOR G620PU-1	0-2	49	ZEN6249	BOLT } * for G62PU	4
11,12	ZEN6211	CRANKCASE COMP.	1	31	ZEN44553	HUB	1	50	ZEN6250	WASHER } * for G62PU	4
13	ZEN6213	CASE PIN	3	32	ZEN6232	PIN FOR G620PU-1	1	51	ZEN6251	PULLER ASS'Y	1
14	ZEN6214	SNAP RING	1	33	ZEN6233	HUB BOLT	2	52	ZEN6252	STOPPER (OPTIONAL)	1
15	ZEN6215	BEARING	2	34	ZEN6234	PROP WASHER	1	53	ZEN6253	PISTON PIN GUIDE (OPTIONAL)	1
16	ZEN6216	REAR OIL SEAL	1	35	ZEN6235	PROP BOLT	1		ZEN6200	SPRING STARTER	1
17	ZEN6217	FRONT OIL SEAL	1	36	ZEN6236	ROTOR	1		ZEN6255	HIGH-SPEED NEEDLE	1
18	ZEN6218	CRANKCASE GASKET	1	37	ZEN6237	SOURCE COIL	1		ZEN6256	LOW-SPEED NEEDLE	1
19	ZEN6219	CASE ASS'Y BOLT	4	38	ZEN6238	IGNITION COIL	1		ZEN6257	MAGNETO ASS'Y	1
20	ZEN6220	PISTON	1	39	ZEN6239	PLUG CAP (BLACK) PLUG CAP SPRING	1				

# Exploded Illustration

## GT80

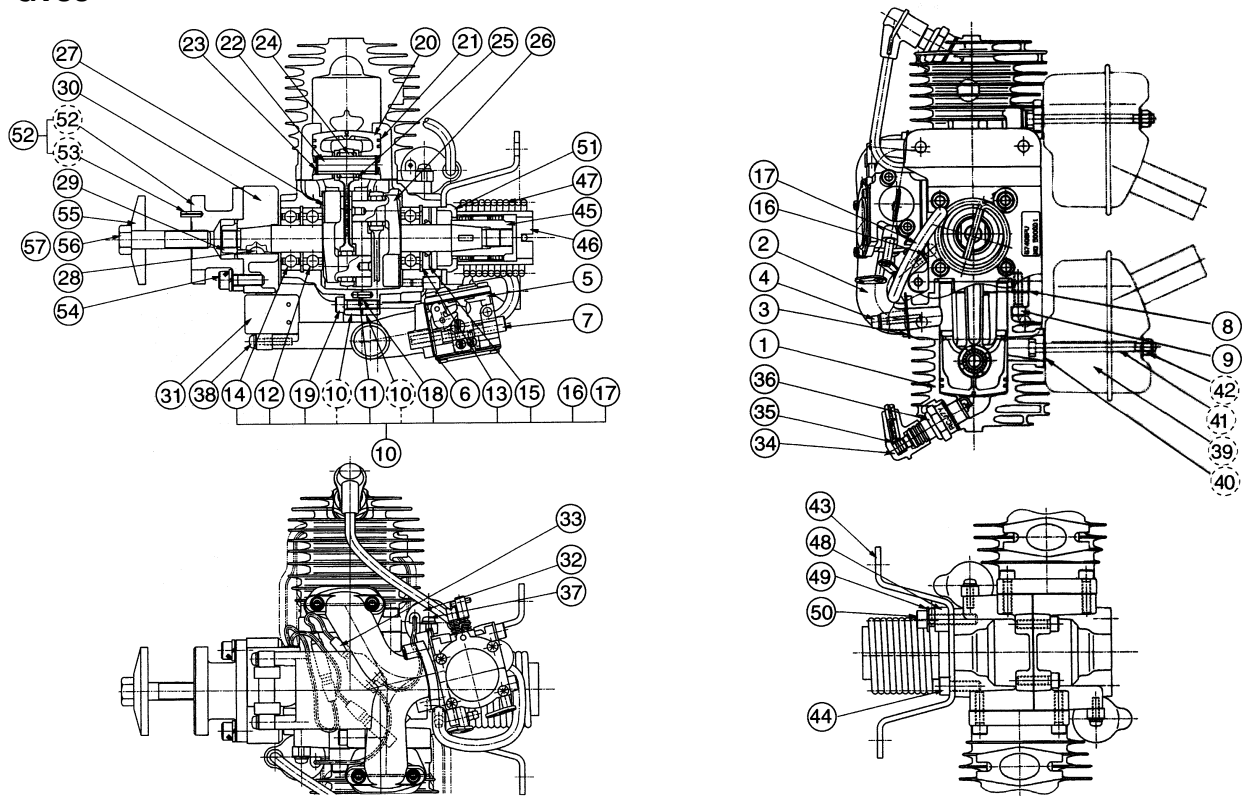

Index No.	Part No.	Description	Q'ty/unit	Index No.	Part No.	Description	Q'ty/unit	Index No.	Part No.	Description	Q'ty/unit
1	ZEN44501	CYLINDER	2	22	ZEN44522	PISTON PIN	2	43	ZEN44543	MOUNT	1
2	ZEN44502	MANIFOLD	1	23	ZEN44523	PIN RETAINER	4	44	ZEN44544	BOLT	3
3	ZEN44503	MANIFOLD GASKET	2	24	ZEN44524	BEARING	2	45	ZEN44545	BOSS	1
4	ZEN44504	MANIFOLD BOLT	4	25	ZEN44525	THRUST WASHER	4	46	ZEN44546	CLUTCH COMP	1
5	ZEN44505	CARBURETOR ASS'Y	1	26	ZEN44526	CRANKSHAFT COMP	1	47	ZEN44547	SPRING	1
6	ZEN44506	CARBURETOR GASKET	1	27	ZEN6228	SHIM	0-2	48	ZEN44548	COLLAR	1
7	ZEN4547	CARB BOLT	2	28	ZEN6227	KEY	1	49	ZEN44549	WASHER	1
8	ZEN44508	CYLINDER GASKET	2	29	ZEN6229	NUT	1	50	ZEN44550	BOLT	1
9	ZEN44509	BOLT	8	30	ZEN6235	ROTOR	1	51	ZEN44551	PAD	1
10	ZEN44510	CRANKCASE ASS'Y	1	31	ZEN6236	SOURCE COIL	1	52	ZEN44552	HUB, PROPELLER COMP	1
11	ZEN6213	PIN	4	32	ZEN6238	IGNITION COIL	2	53	ZEN44553	PIN	2
12	ZEN6215	BEARING	2	33	ZEN44533	CORD	1	54	ZEN6232	HUB BOLT	2
13	ZEN6214	SNAP RING	2	34	ZEN6238	PLUG CAP (BLACK)	2	55	ZEN6233	HUB WASHER	1
14	ZEN44514	BEARING	1	35	ZEN6239	CAP SPRING	2	56	ZEN6234	PROP BOLT	1
15	ZEN6217	FRONT OIL SEAL	1	36	ZEN6242	SPARK PLUG, C859	2	57	ZEN6247	TAP PROP BOLT	1
16	ZEN6276	FUEL NIPPLE ELBOW	1	37	ZEN44537	SCREW	4	58	ZEN44555	SOCKET	1
17	ZEN44517	PIPE	1	38	ZEN44538	SCREW	2	59	ZEN6251	PULLER ASS'Y (OPTIONAL)	1
18	ZEN44518	CRANKCASE GASKET	1	39	ZEN44539	MUFFLER	2	60	ZEN44554	STOPPER (OPTIONAL)	1
19	ZEN44509	BOLT	4	40	ZEN44540	MUFFLER GASLET	2		ZEN44556	HIGH-SPEED NEEDLE	1
20	ZEN44520	PISTON	2	41	ZEN6209	MUFFLER BOLT	4		ZEN44557	LOW-SPEED NEEDLE	1
21	ZEN44521	PISTON RING	4	42	ZEN44542	NUT					

## G80A

Index No.	Part No.	Description	Q'ty/unit
01	ZEN8001	CYLINDER	2
02	ZEN8002	INTAKE MANIFOLD (BLACK)	1
20	ZEN8020	PISTON	2
21	ZEN8021	PISTON RING	2



# Warranty Information

---

Zenoah® engines are guaranteed against workmanship and manufacturing defects for a period of 3 years from the original date of purchase. This warranty is limited to the original purchaser and is not transferable.

Warranty repairs will **not** cover:

- Normal engine wear
- Damage due to insufficient maintenance
- Damage related to over-revving of the engine due to small prop size or unreasonable use
- Rusted bearings
- Crash damage
- Damage due to use of improper fuel and/or spark plug
- Damage due to lean runs, such as rusted bearings, seized connecting rod or piston, etc.
- Damage caused by foreign objects
- Damage caused by unreasonable mounting or running conditions (dust, insufficient cooling, improper mounting, improper propeller size or lack of balancing, etc.)
- Damage due to improper disassembly
- Modifications of any kind

If your engine needs repair, ship it in its original box, freight prepaid to:

Horizon Service Center  
Attn: Zenoah Service  
4105 Fieldstone Road  
Champaign, IL 61822  
Phone: (217) 355-9511

**Note:** Do not use the engine's original box as the shipping box. Rather, package this box inside a sturdy shipping box.

1. Include complete name and address information inside the carton, as well as clearly writing it on the outer label/return address area.

2. Include a note containing a brief summary of the difficulty and include the following information:

- Propeller size and brand used
- Type of spark plug used
- Type of engine mount
- Approximately how much running time the engine had before difficulty

3. Date your correspondence and be sure your name and address appear on this enclosure.

4. Include a phone number where you can be reached during the business day.

## Warranty Repairs

To receive warranty service you must include your original dated sales receipt to verify your proof-of-purchase date. Providing that warranty conditions have been met, your engine will be repaired without charge.

## Non-Warranty Repairs

Should your repair cost exceed 50% of the retail purchase cost, you will be provided with an estimate advising you of your options. Any return freight for non-warranty repairs will be billed to the consumer.

We accept both Visa and MasterCard for payment. Please include your card number and expiration date.

The Consumer Warranty Registration below must be completely filled out and mailed to:

Horizon Service Center  
Attn: Zenoah Warranty  
4105 Fieldstone Road  
Champaign, IL 61822

# Warranty Information (continued)

---

## Registration Form

Fill in and mail this form along with your dated sales receipt (send a copy, keep the original for your files) within 10 days of purchase to:

Horizon Service Center  
Attn: Zenoah Warranty Dept.  
4105 Fieldstone Road  
Champaign, IL 61822

Engine Type: \_\_\_\_\_

Date of Purchase: \_\_\_\_\_

Owner's Name: \_\_\_\_\_

Street Address: \_\_\_\_\_

City/State/Zip: \_\_\_\_\_

Daytime Phone Number: \_\_\_\_\_

Purchased From: \_\_\_\_\_

Dealer's Name: \_\_\_\_\_

Street Address: \_\_\_\_\_

City/State/Zip: \_\_\_\_\_

-----

Please cut on dotted line.



