

**IMPORTANT
INSTALLATION INSTRUCTIONS
for**

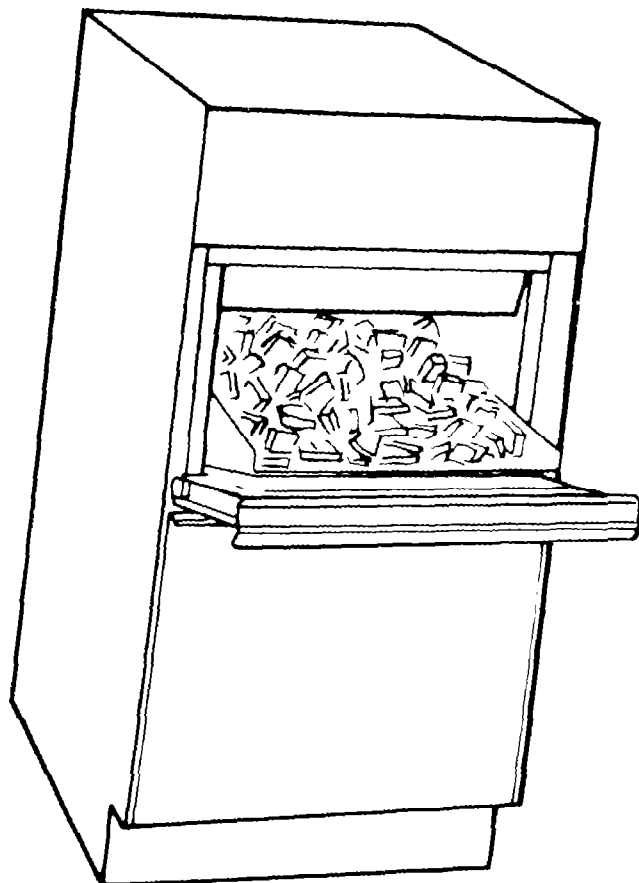

**Whirlpool**
CORPORATION

**ICE MAKER
Model 50**

CHANGING THE BIN DOOR PANEL

The storage bin door is designed to accept an optional decorative wood panel of your choice.

The wood panel should be no more than ¼ inch (6 mm) thick. Cut it to the same size as the production metal panel. See Figure 1.

To change the panel:

1. Open the bin door.
2. Remove the two screws on top of the door which hold the handle.
3. Remove the handle.
4. Slide the metal panel out.
5. Break off the ribs on the door insulation to allow for the wood thickness. See Figure 2.
6. Slide the wood panel into the door frame.
7. Replace handle and screws.

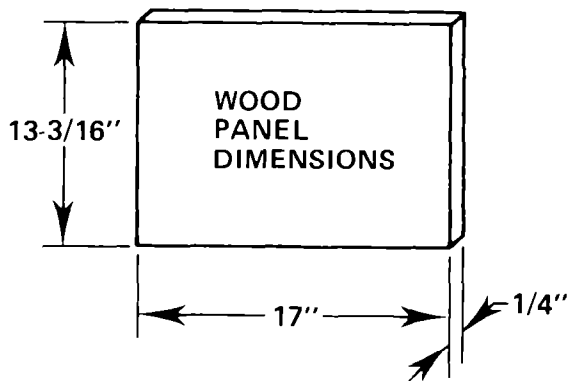

FIGURE 1

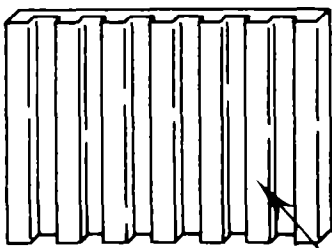

FIGURE 2

THERMOSTAT CALIBRATIONS

If ice maker is installed above two thousand feet of altitude, the bin and evaporator thermostats must be adjusted to a warmer setting. Disconnect electricity, remove thermostat and follow the directions for turning the altitude adjustment screw as shown in the label on each thermostat.

SHIPBOARD OPERATION

When this ice cube maker is installed aboard a ship, it will be necessary to purchase and install a water deflector. This deflector hangs between the lower edge of the evaporator and the cutter grid. It keeps the water flowing over the evaporator from spilling into the storage bin area. Order the necessary parts from your local ice maker dealer.

GENERAL INFORMATION

• UNPACK

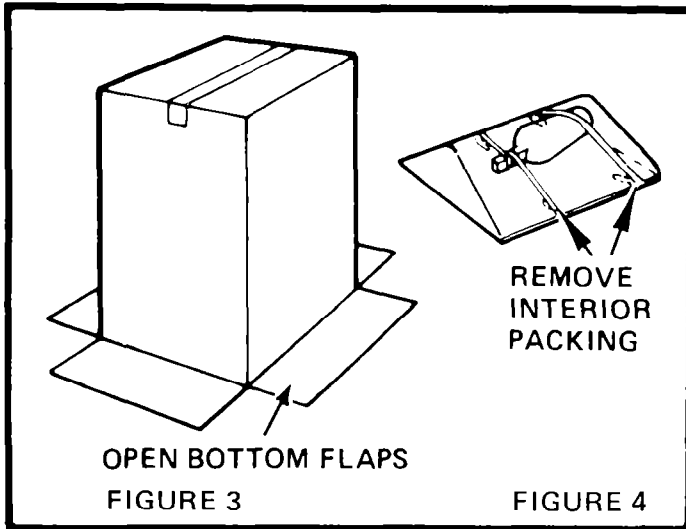

- 1 Lay carton on rear face and break open bottom flaps.
- 2 Set carton upright with all four flaps outward. See Figure 3.
- 3 Lift container up and off of machine.
- 4 Remove all tape and packaging material from the outside and inside of the cabinet. See Figure 4.
- 5 Remove the front grill; take out the screws securing the grill at the bottom and lift it free of cabinet.
- 6 Turn the fan by hand to make certain it moves freely.
- 7 Loosen thumb screws holding cutter grid and water pan to "thumb tight."

• UTILITIES

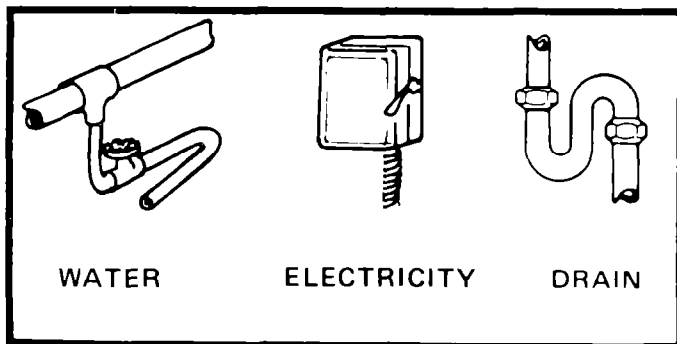

OBSERVE LOCAL CODES

Each installation is unique but will require:

- 1 A cold water inlet of 1/4" OD soft copper tubing and a shut-off valve.

- 2 Either a gravity drain system or a sump pump to lift the water to an existing drain.
- 3 An electrical branch circuit of 115 Volt, 60 Hz, 1 phase, with a 15 Amp delayed action fuse.

• LOCATE UNIT

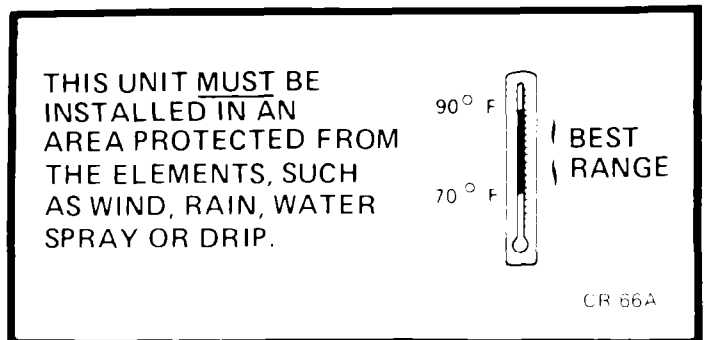

- 1 Place unit so the front side will be completely unobstructed, to provide proper air flow.
- 2 Area should be well ventilated with temperature above 55°F and below 110°F. Best results are obtained between 70°F and 90°F.
- 3 Provision for electricity, water and drain connections should be determined.
- 4 The unit may be closed in on the top and three sides, but the front **MUST BE** unobstructed for air circulation and proper operation. Installation should be such that the cabinet can be moved forward for servicing, if necessary.

• LEVEL UNIT

- 1 After placing unit in position, check to make certain the unit is level side to side and front to back.
- 2 Accurate leveling is essential for proper operation.
- 3 Unit should be shimmed so that it is solid as well as level. The shims should be of hard permanent type material such as masonite.
- 4 If required by sanitation code, seal the cabinet to the floor with an approved caulking compound.

FOR THE PLUMBER

CONNECT TO WATER

(observe local codes)

- 1 Use 1/4" OD soft copper tubing for the cold water supply.
- 2 Provide a convenient manual shut-off valve in the water line.
- 3 Position the tubing so it can enter the access hole located in the right-hand rear of the cabinet. The tubing should extend beyond the cabinet front when the cabinet is pushed back into position. See Figure 5.

NOTE:

Always purge the water line before making the final connection to the inlet of the water valve to prevent possible water valve malfunction.

After the cabinet is in place, bend the tubing to meet the connection at the water valve. The garden hose threaded compression fitting is found in the parts bag. This joint provides a convenient disconnect for service. Be sure the tubing is clear of compressor, to prevent rattle.

CONNECT THE DRAIN

(observe local codes)

- 1 The unit is provided with a gravity drain.
- 2 The ideal installation has a standpipe (1 1/4" minimum) installed directly below the outlet of the drain tube. Refer to Figure 5 for the proper location of the standpipe.
- 3 It may be desirable to insulate drain line thoroughly up to drain inlet.

SUMP PUMP

- 1 When a drain connection below the level of the unit is not available, a sump pump may be used to lift the water to an available drain.
- 2 Install sump pump on floor behind ice maker with discharge tube to the rear. Run bin drain directly into sump pump as shown in the illustration.

NOTE:

Electric connection to sump pump should be from a circuit that remains energized continually.

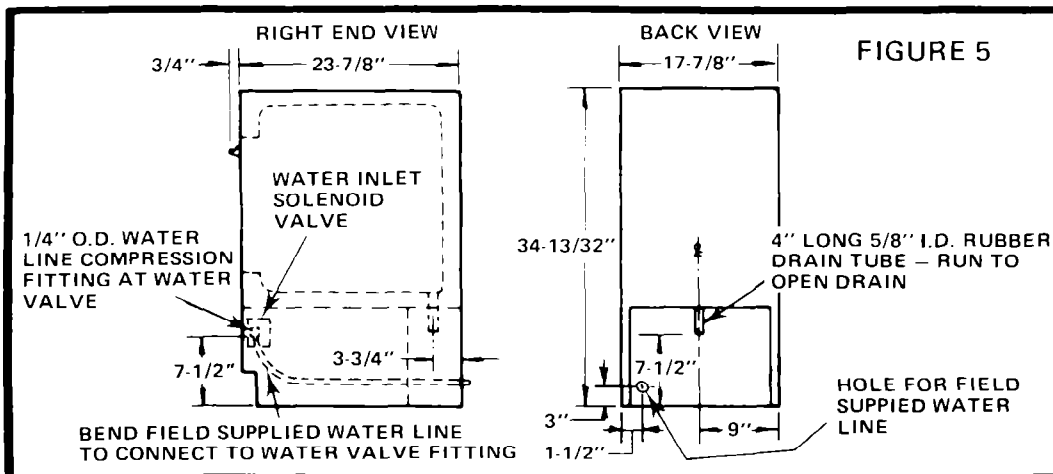
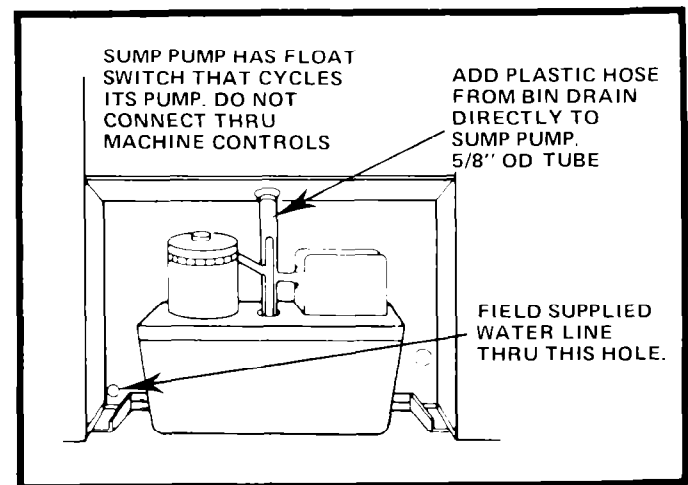

FOR THE ELECTRICIAN

ELECTRICAL REQUIREMENTS

A 115 Volt, 60 Hz, AC only, 15 Amp fused electrical supply is required (time delay fuse or circuit breaker is recommended). It is recommended that a separate circuit, serving only this appliance, be provided. DO NOT use an extension cord.

ELECTRICAL GROUND IS REQUIRED ON THIS APPLIANCE.

RECOMMENDED GROUNDING METHOD

DO NOT, UNDER ANY CIRCUMSTANCES, REMOVE THE POWER SUPPLY CORD GROUND PRONG.

For your personal safety, this appliance must be grounded. This appliance is equipped with a power supply cord having a 3-prong grounding plug. To minimize possible shock hazard, the cord must be plugged into a mating 3-prong grounding type wall receptacle, grounded in accordance with the National Electrical Code and local codes and ordinances. If a mating wall receptacle is not available, it is the personal responsibility and obligation of the customer to have a properly grounded 3-prong wall receptacle installed by a qualified electrician. See Figure 6.

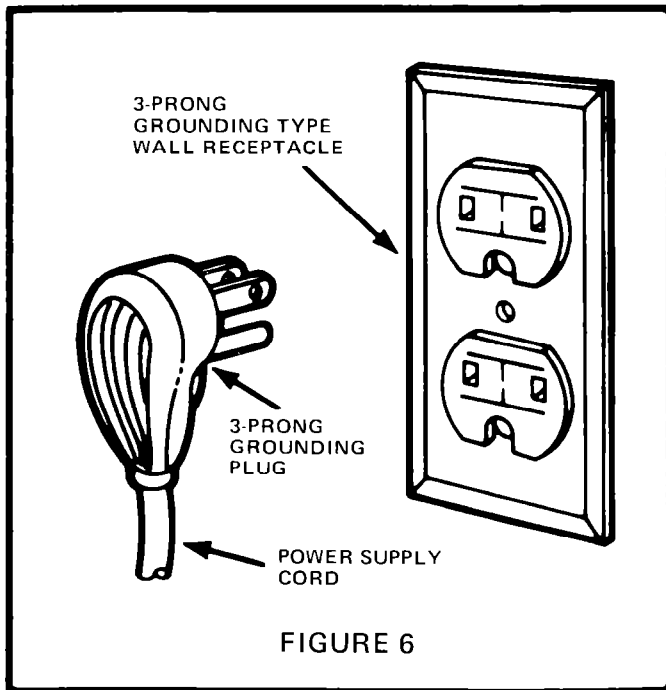

ALTERNATE GROUNDING METHOD

DO NOT, UNDER ANY CIRCUMSTANCES, REMOVE THE POWER SUPPLY CORD GROUND PRONG.

If changing and properly grounding the wall receptacle is impossible and where local codes permit (consult your electrical inspector), a temporary adapter may be plugged into the existing 2-prong wall receptacle to mate with the 3-prong power supply cord. See Figure 7. **THIS, HOWEVER, IS NOT RECOMMENDED.**

If this is done, you must connect the grounding eyelet on the adapter to the wall receptacle cover plate screw and from this same screw, you must connect a separate copper ground wire (No. 4 minimum) to a grounded cold water pipe*. See Figure 7. Do not ground to a gas supply pipe. Do not connect to electrical supply until appliance is permanently grounded.

*Cold water pipe must have metal continuity to electrical ground and not be interrupted by plastic, rubber or other electrically insulating connectors (including water meter or pump) without adding a jumper wire at these connections

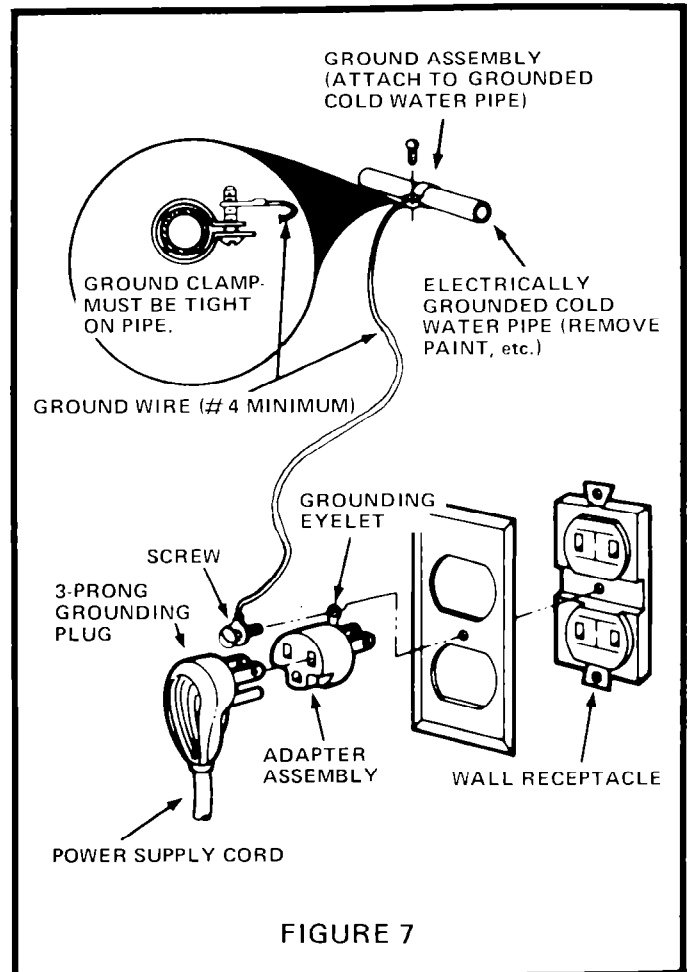

HOW IT WORKS

- Compressor runs
- Condenser fan runs
- Water pump runs (circulates water)
- Cutter grid is warm to touch

WHEN THE DESIRED ICE SLAB THICKNESS IS REACHED, THE HARVEST CYCLE BEGINS AND THE FOLLOWING HAPPENS:

- Evaporator thermostat is satisfied
- Compressor keeps running
- Condenser fan stops or turns very slowly
- Water pump stops
- Hot gas solenoid opens
- Water inlet valve opens
- Excess water is flushed out of the drain pan
- Cutter grid is warm to the touch

NOTE: Normal harvest cycle takes 60 to 120 seconds.

MACHINE RESUMES FREEZING AFTER SLAB IS RELEASED FROM EVAPORATOR AND THE CUTTING PROCESS BEGINS.

WHEN THE STORAGE BIN IS FILLED, BIN THERMOSTAT OPENS.

- Cutter grid remains on

THINGS TO REMEMBER

- Water enters only during the defrost cycle. Therefore the first cycle will be completed without water in the system.
- As the room and water temperatures vary, so will the amount of ice produced. This means that higher operating temperatures will result in reduced ice production.
- The unit will shut off when ice in the storage bin touches the bin thermostat well and will automatically cycle to keep the bin full.
- The storage bin is not refrigerated and some meltage will occur. This, too, varies with the room temperature.
- The unit needs good air circulation to perform efficiently. Keep the front grill and the condenser clean.
- The water system, including filter screen in the water inlet solenoid valve, needs to be cleaned periodically for good circulation. Instructions are located on the inner door panel.

OPERATING INSTRUCTIONS

- For complete operating information, refer to the Use and Care Guide.
- Before starting, wash out interior of cabinet with a Baking Soda solution (2 tablespoons soda to a quart of warm water). Rinse thoroughly.
- Make certain the water is turned on.
- Turn switch to the "ON" position.

IMPORTANT:

Allow unit to run for 3 hours before expecting ice and for 24 hours before trying to set the thickness control.

If installed above 2,000 feet altitude, see page 2 for thermostat adjustments.

UNIT WIRING DIAGRAM

This model operates at 115 volts except for the cutter grid circuit which operates at 8.5 volts at 1 amp.

The compressor runs at all times except when the bin thermostat becomes satisfied and opens up. This de-energizes the system except for the transformer and cutter grid.

Under normal operating conditions, when the evaporator reaches the preset temperature (+10° to -3° F, depending on thickness of ice) the evaporator thermostat opens, terminating operation of the fan motor and pump motor. The hot gas solenoid and the water valve solenoid are energized at this time and remain so until the evaporator reaches 38 + 2° F.

DANGER: ELECTRIC SHOCK HAZARD
DISCONNECT POWER BEFORE SERVICING UNIT
MAXIMUM FUSE SIZE: 15 AMPS.
NOTE: CONTACTS SHOWN IN FREEZING CYCLE.

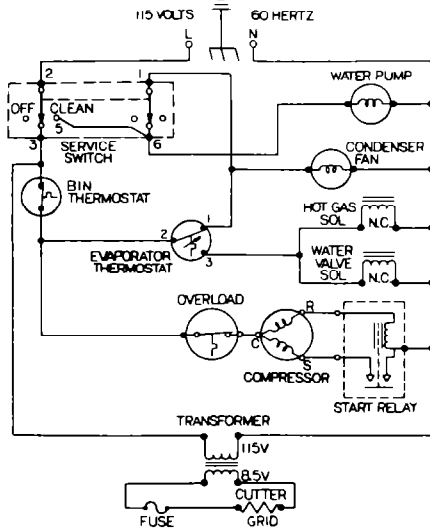

YOUR UNIT MAY OR MAY NOT BE EQUIPPED WITH A CUTTER GRID FUSE.

COLOR CHART	
R	RED
BK	BLACK
BU	BLUE
W	WHITE
Y	YELLOW
O	ORANGE

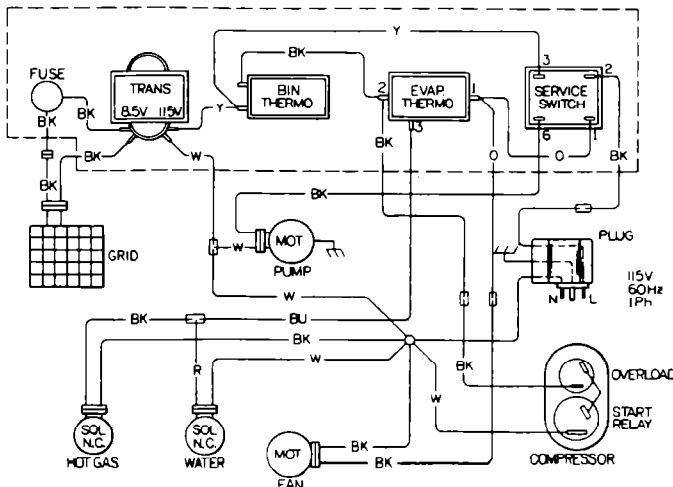

CUBELET CUTTER GRIDS

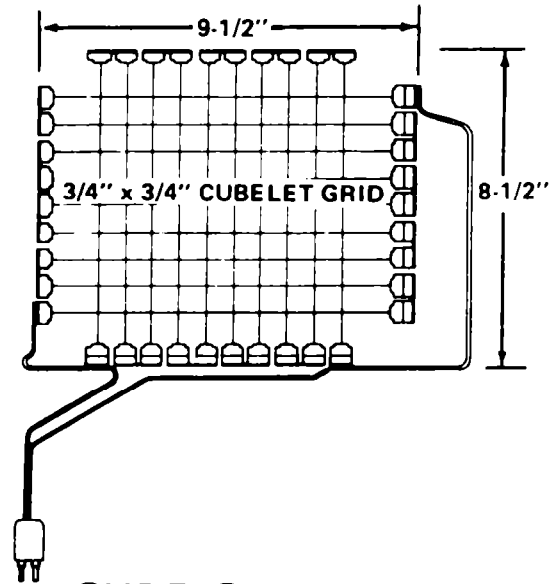

CUBE CUTTER GRID

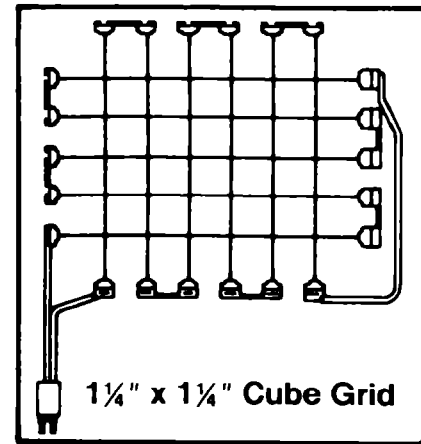

CHECK OPERATION

- ✓ Start the unit by turning the service switch to "ON" and opening the line water valve.
- ✓ NOTE: Left is "OFF" — Middle is "ON" — Right is "CLEAN." In "CLEAN" position, only the pump operates.
- ✓ Check condenser fan to make sure it is revolving.
- ✓ Water will not enter pump pan until freezing plate gets cold and machine goes into a harvest cycle.
- ✓ Check for even water flow over freezing plate. Unit must be level for proper operation.
- ✓ Check for desired cube thickness and after 24 hours adjust if necessary. Maximum ice yield will be obtained with ice thickness at 1/2" to 5/8".
- ✓ Replace grill.



Quality. Our way of life.

Benton Harbor, Michigan. Automatic Washers. Clothes Dryers. Freezers. Refrigerator-Freezers. Ice Makers. Dishwashers. Built-in Ovens and Surface Units. Ranges. Microwave Ovens. Compactors. Room Air Conditioners. Dehumidifiers. Central Heating and Air Conditioning Systems