

RF0300/0650/1200 Flake Ice Machines Ice Chute Replacement Kit Instructions

STEP 1

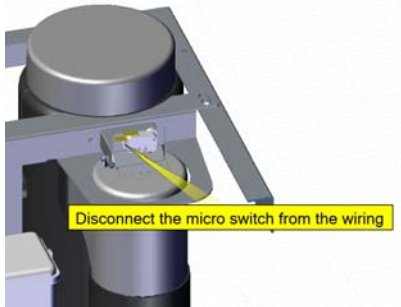

STEP 5

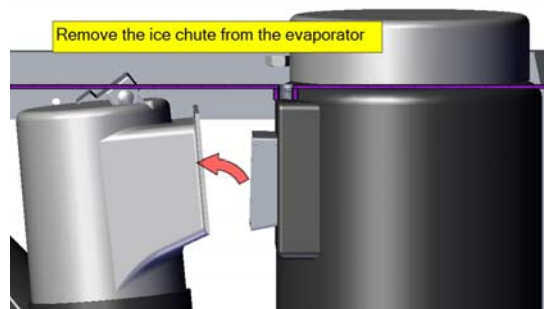

STEP 2



STEP 6



STEP 3

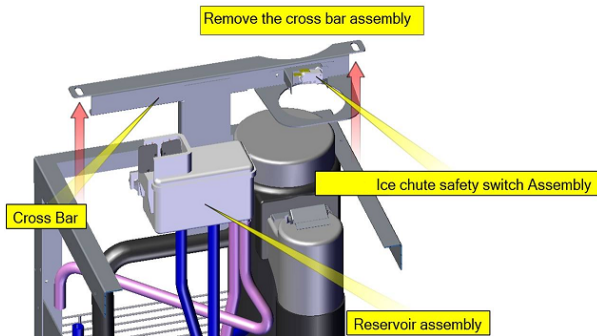

STEP 7

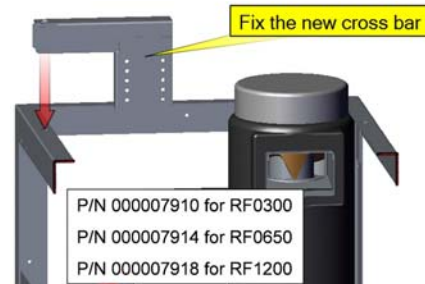

STEP 4



STEP 8

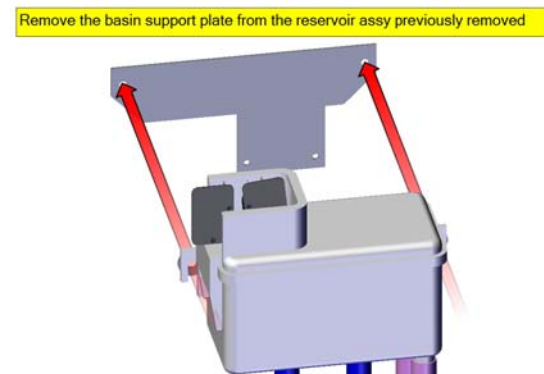

STEP 9

Rotate the basin support plate 180° and re-attach to reservoir assembly

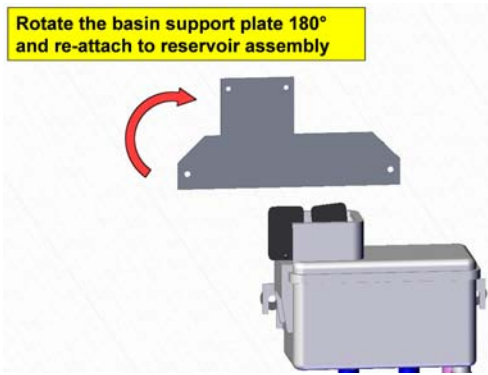

STEP 13

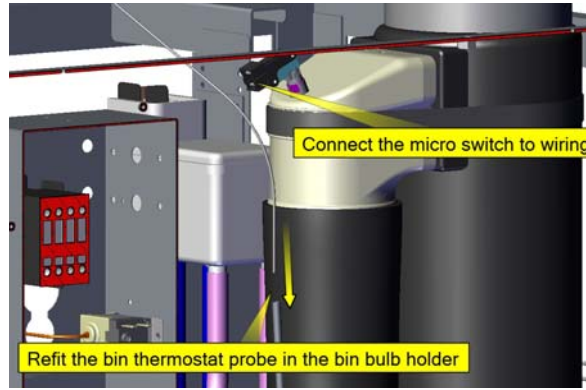

STEP 10

Re-attach reservoir assembly to cross bar

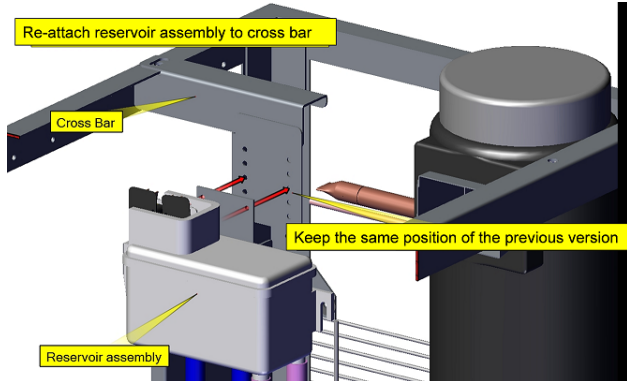

STEP 11

Join upper and lower assemblies

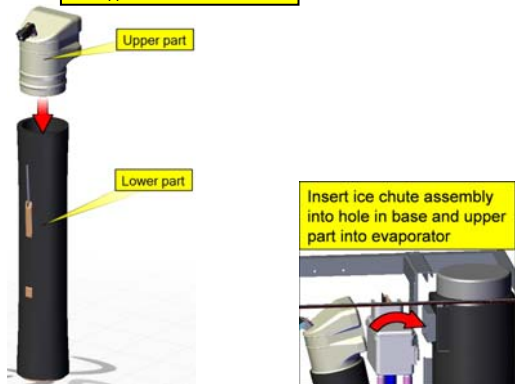

STEP 12

