



**Manitowoc**

# K00384 Ice Machine Stand

## Installation Instructions

### **WARNING**

The stand must be secured to the wall with the bracket and fasteners provided in this kit.

The security bracket must be attached to two studs.

The ice machine must be secured to the stand top cover with the supplied bolts (4) and washers (4).

The stand top cover must be secured to the stand with the screws (2) provided.

### Material List



TOP  
PANEL



REAR  
PANEL



FRONT  
PANEL



BRACE  
PANEL  
(2)



SIDE  
PANEL  
(2)



CAP  
PLUG  
(4)



TOP  
COVER  
SCREWS  
(2)



SUPPORT  
ANGLE  
(2)



LEG  
(4)



BASE



TOP  
COVER



BOLT (4)  
WASHER (4)

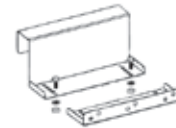

SECURITY  
BRACKET  
BOLT (2)  
WASHER (2)  
NUT (2)

### Cabinet Assembly

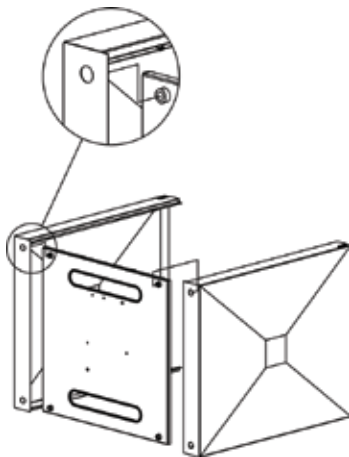

**Step 1** - Slide side panels onto base.

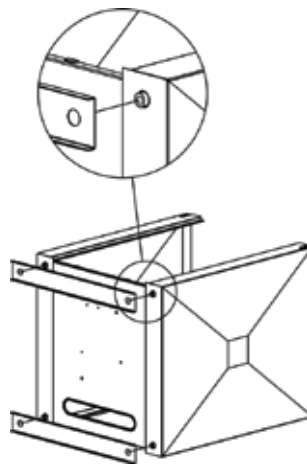

**Step 2** - Place support angles under the side panels.

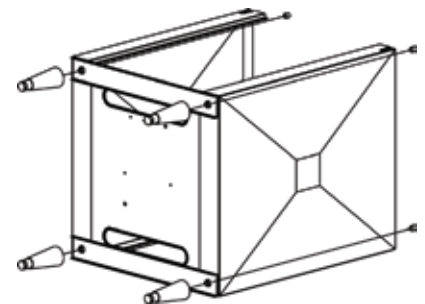

**Step 3** - Screw legs into the base (through support angles & side panels).

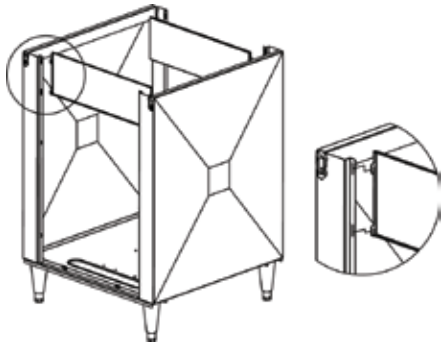

**Step 4** - Place brace panels on the inside of the frame, engaging the hook flanges of the brace to the rectangular slots on the side panels.

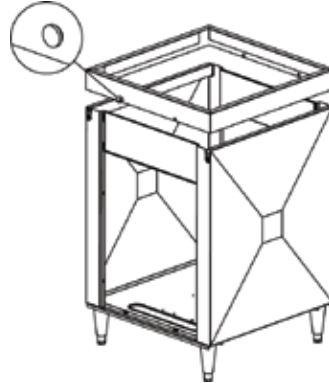

**Step 5** - Place the top panel with the rubber grommets along open sides.

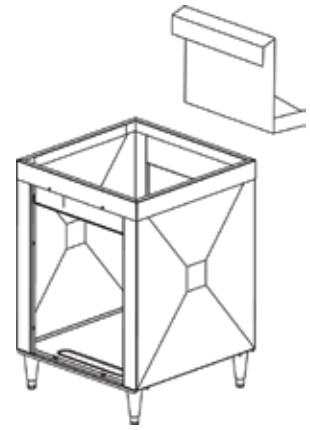

**Step 6** - Install ½ of the security bracket to stand.



**WARNING**

This stand must be secured to a wall to prevent tipping.



**Step 7** - Install top cover onto stand.

**Step 8** - Install rear panel.

**Step 9** - Move into position and level front to back and side to side.

**Step 10** - Locate studs in wall and mark bracket screw locations (2 studs must be used).

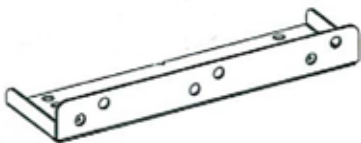

**Step 11** – Provide screws suitable for your building material and mount second ½ of bracket to wall.

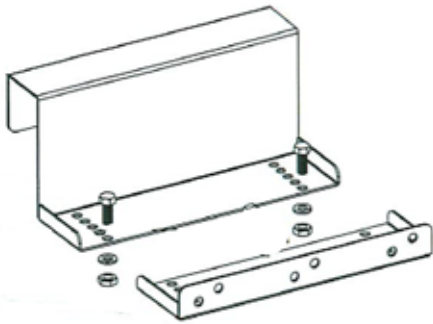

**Step 12** - Move stand into position and secure 2 bracket halves with provided bolts, washers and nuts.

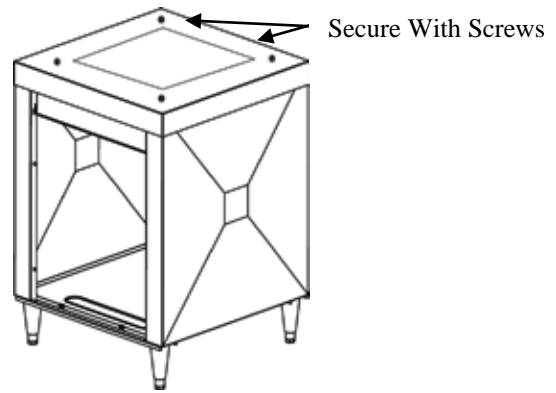

**Step 13** - Secure stand top to stand with provided screws through the rear of the stand.



**Step 14** - Place ice machine on stand.

**Step 15** - Secure the ice machine to the stand with provided bolts and washers (access thru front door to align holes).

**Step 16** - Refer to Installation Use and Care Manual and install ice machine. Water, drain and electrical connections can be made out the back or through the bottom of the ice machine.

**Step 17** - Install removable front panel.