

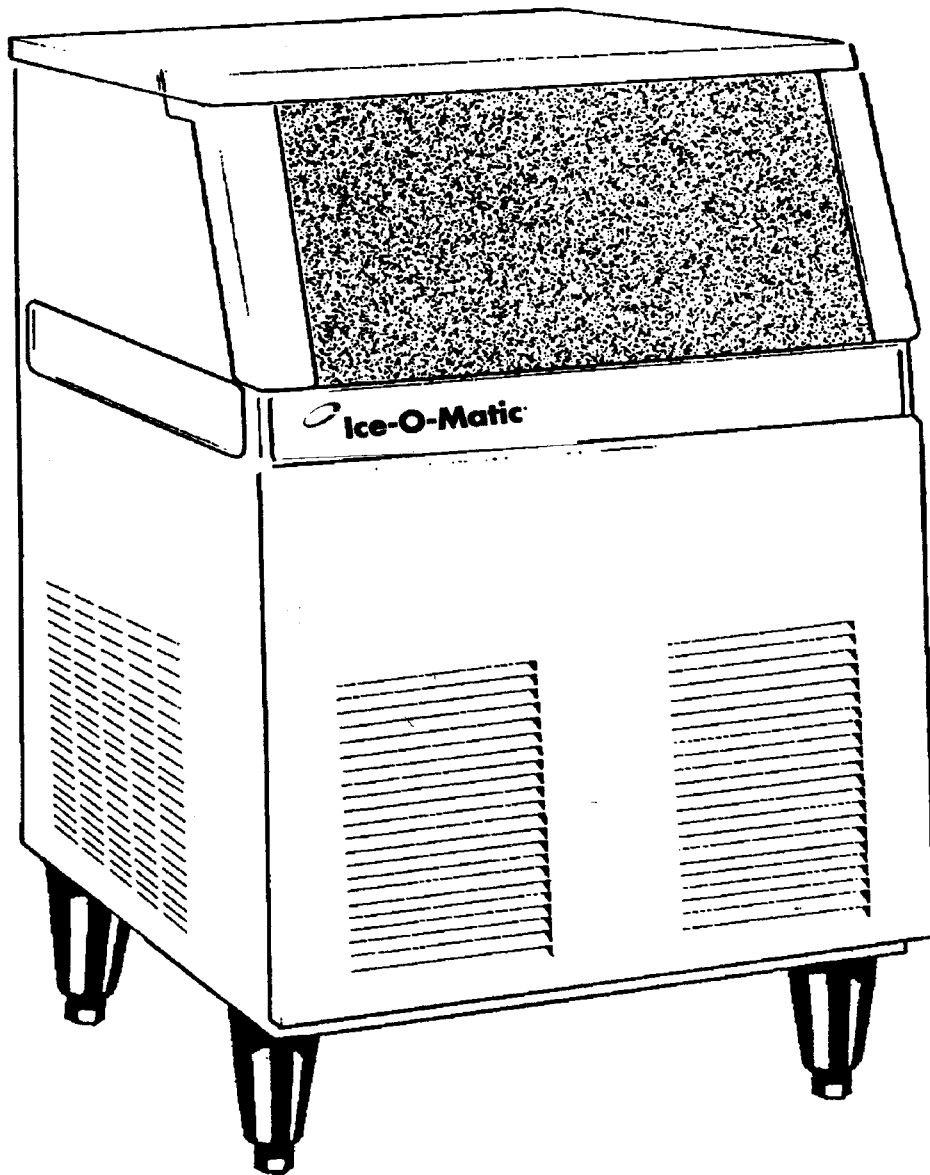

Ice-O-Matic®

SERVICE AND INSTALLATION MANUAL ICE UNDERCOUNTER SERIES CUBERS MODEL-ICEU060



Mile High Equipment
11100 East 45th Ave
Denver, Colorado 80239

Part Number 9081291-01

Print Date 11/01

To the owner or user: This product manual is a source of information about the installation, start up, cleaning, maintenance, and repair of the product.

Table of Contents

Introduction	Page 1
Specifications/Limitations	Page 2
Installation	Page 3-5
Initial Start Up	Page 6
How It Works-Component Description	Page 7
Component Location	Page 8
How It Works-Water System	Page 9
How It Works-Refrigeration	Page 10-11
Operation And Adjustment	Page 12
Sanitizing And Cleaning	Page 13
Service Diagnosis	Page 14
Component Replacement	Page 15-16
Wiring Diagram	Page 17-18
Warranty Information	Page 2

Note the warning symbol where it appears in this manual. It is an alert for important safety information on a hazard that might cause serious injury. Keep this manual for future reference.



Ice-O-Matic
11100 E. 45th Ave.
Denver, Co. 80239
800-423-3367

The ICEU060 Service Parts Manual is available separately, Part Number 9081291-02

Specifications:

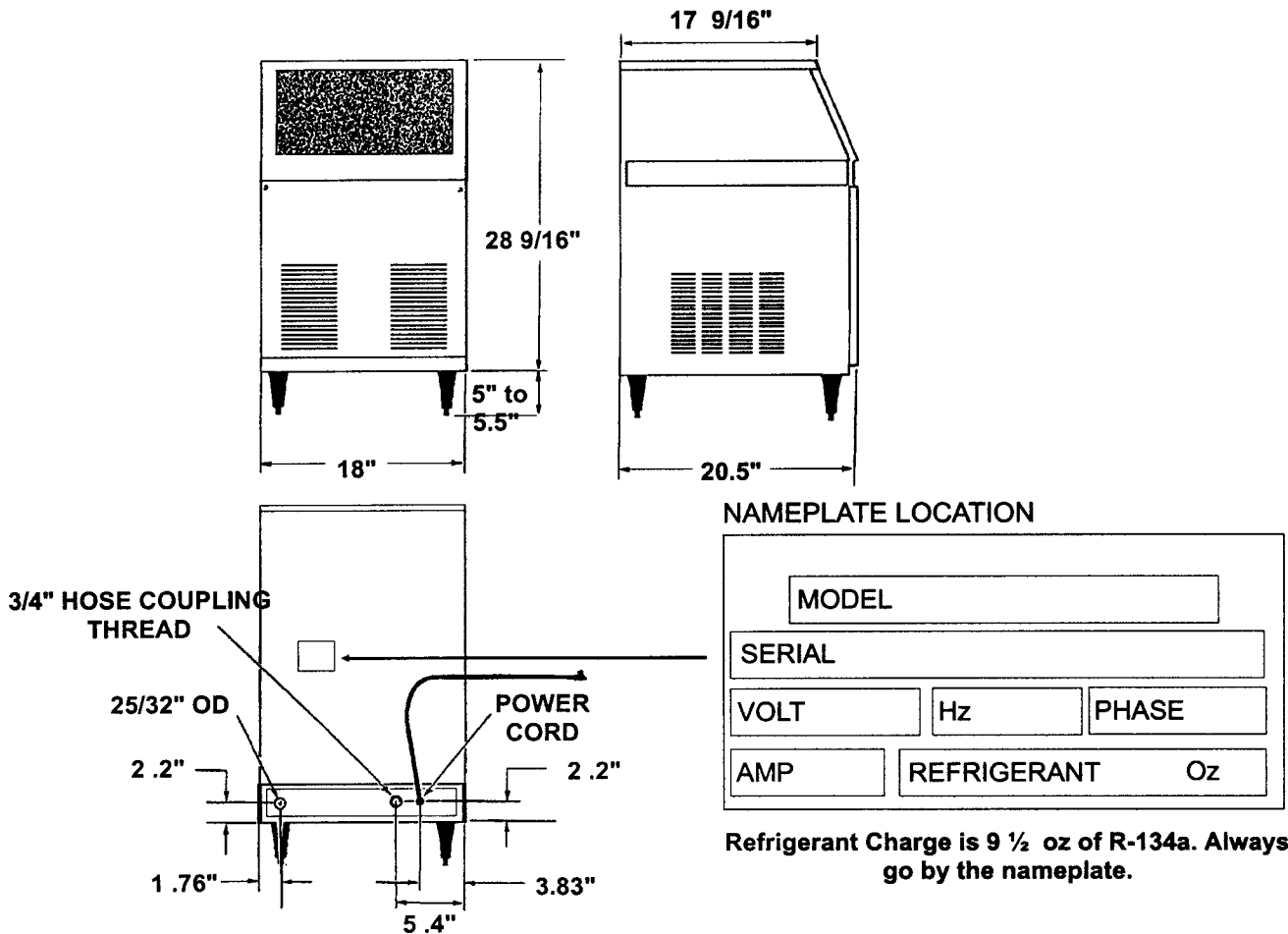

<u>Model Number</u>	<u>24 Hour Capacity</u>	<u>Bin Storage Capacity</u>	<u>Basic Electrical</u>	<u>Maximum Fuse Size</u>	<u>Ref Type. Ounces</u>
ICEU060	55 lbs.	28 lbs.	115/60/1	15	R134a, 9.5 oz

Operating Requirements:

	<u>Minimum</u>	<u>Maximum</u>
Air Temperature	50° F	100° F
Water Temperature	40° F	100° F
Water Pressure	20 PSIG	100 PSIG
Voltage	103.5 V	126.5 V

Ice-O-Matic ice machines are not designed for outdoor installations.

Machine requires voltage indicated on rating nameplate. Failures caused by improper voltage are not considered factory defects. Extended periods of operation at temperatures exceeding limitations constitutes misuse under the terms of the Ice-O-Matic Manufacture's Limited Warranty, resulting in a loss of warranty coverage. Specifications and design are subject to change without notice.

The ICEU060 ice machine has a 3 year Parts Warranty and a 3 year Labor Warranty. The Compressor and Evaporator have a 5 year Parts Warranty. Ice-O-Matic recommends the installation of water filters.

Location:

Prior consideration for the location of the ice machine shall include:

Installation location to be indoors with a minimum room temperature of 50°F and with a maximum room temperature of 100°F.

The incoming water temperature to the machine should be between 40°F and 100°F.

Service Access. Allow enough space at the rear of the cabinet for the utility connections. Allow enough space for the machine to be pulled out from its installed location. Do not build a floor in front of the machine that would prevent its removal.

Air Circulation. The front panel **must** remain unobstructed. Do not block the front panel area with any type of door or curtain. The air intake is on the right hand side of the front panel, and the exhaust is on the left side of the front panel and the cabinet left hand side panel. If the unit is installed in a “built-in” cabinet, position the machine so that the left side of the unit is tight against the cabinet.

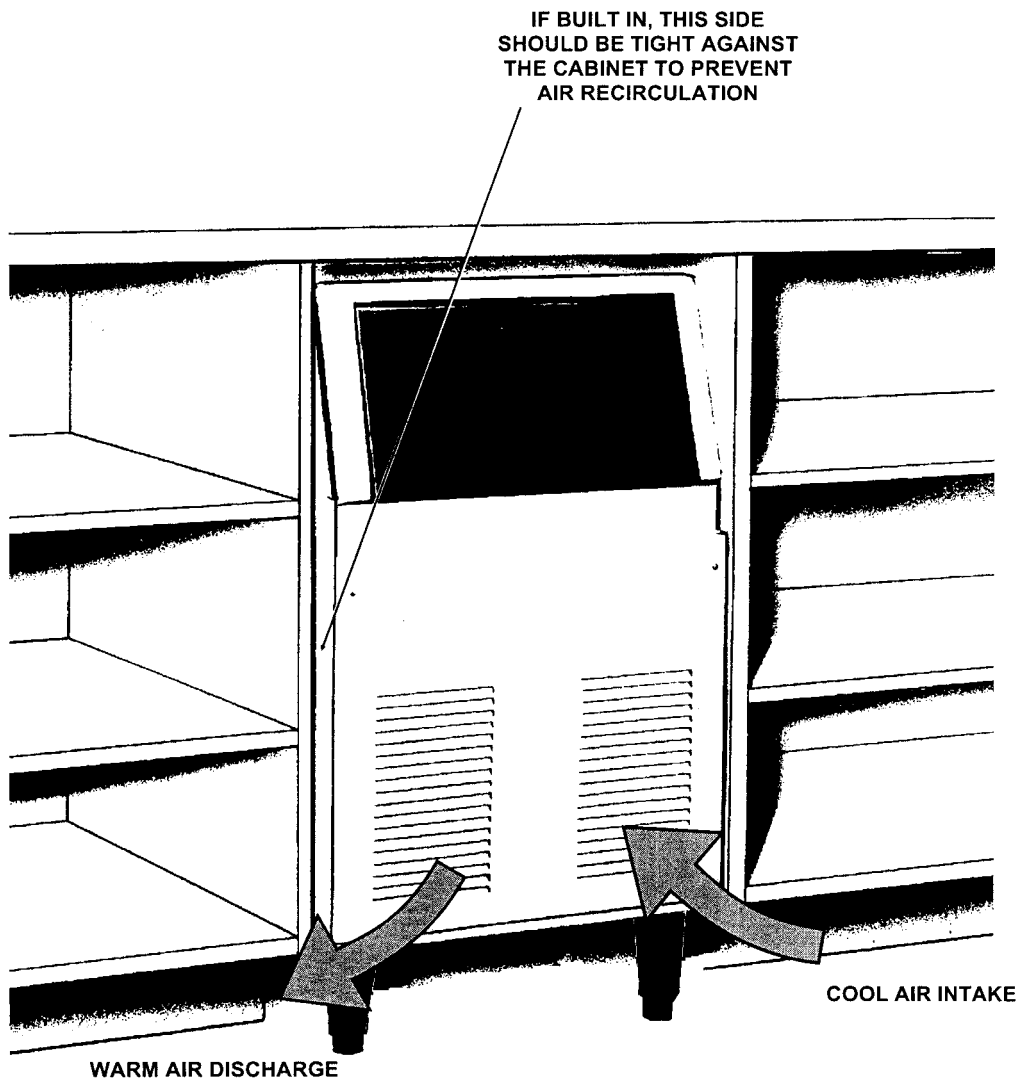

Water Supply and Drain Connection:

1. The recommend water supply line is ¼ inch O.D. copper tubing. The minimum incoming water pressure should be 20 psig.
2. Connect the water supply tubing to the water inlet fitting (3/4 hose thread) at the rear of the icemaker. An optional adapter (1/4 compression x ¾ hose thread) is available under part number 1011337-43, or from a local hardware store
3. Install a water shutoff valve on the incoming water line near the icemaker so that the water can be shut off for service.
4. Connect a gravity drain line to the drain connection at the icemaker. A minimum slope of ¼ inch fall per foot of horizontal run is recommended. Install the drains per local code. A vent is recommended on the highest point of the drain tube, and the drain tubing must be rigid pipe. DO NOT use flexible tubing.

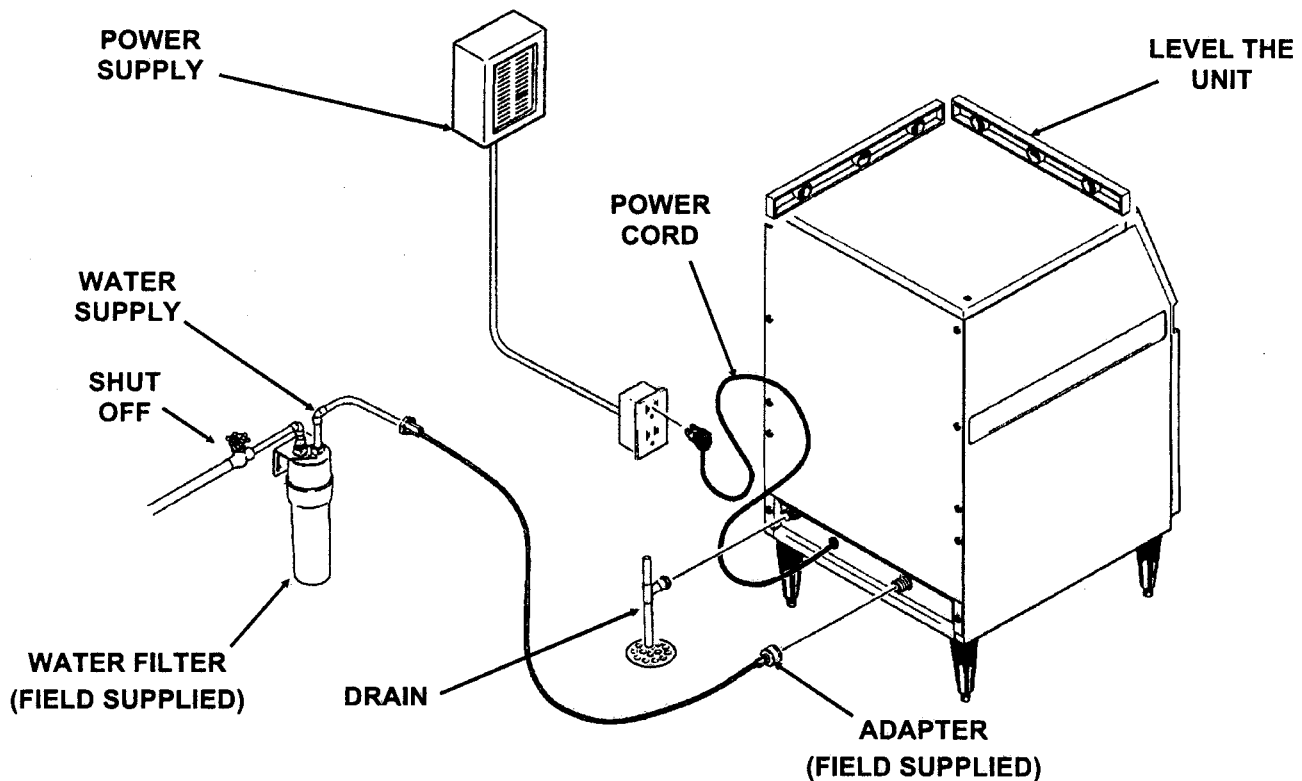

Electrical

1. Locate the nameplate on the lower rear panel and check that the location source voltage and capacity are correct for this unit. The unit is supplied with a grounded plug connection.
2. **Under no circumstances must the ground post be altered or removed.**
3. Be certain that the icemaker is connected to its own electrical circuit and is individually fused.
4. The maximum allowable voltage variation should not exceed ten percent of the name plate rating.
5. All external wiring should conform to the National, State, and local electrical code requirements. Usually an electrical permit and the services of a licensed electrician will be required to install the receptacle.

Final Check:

1. Is the cabinet level?
2. Have all the electrical and piping connection been made?
3. Has the voltage been tested and checked against the nameplate rating?
4. Is the unit plugged into a separate electrical circuit?
5. Is the water supply line shut off valve installed and is the water turned on?
6. Have the bin interior and cabinet exterior been wiped clean?
7. Are all internal components in place including spray platform and curtain?
8. Have the internal refrigerant lines been checked for rubbing and chaffing?
9. Has the machine been installed indoors, in a controlled environment with adequate air circulation around the machine, and where it can be serviced?

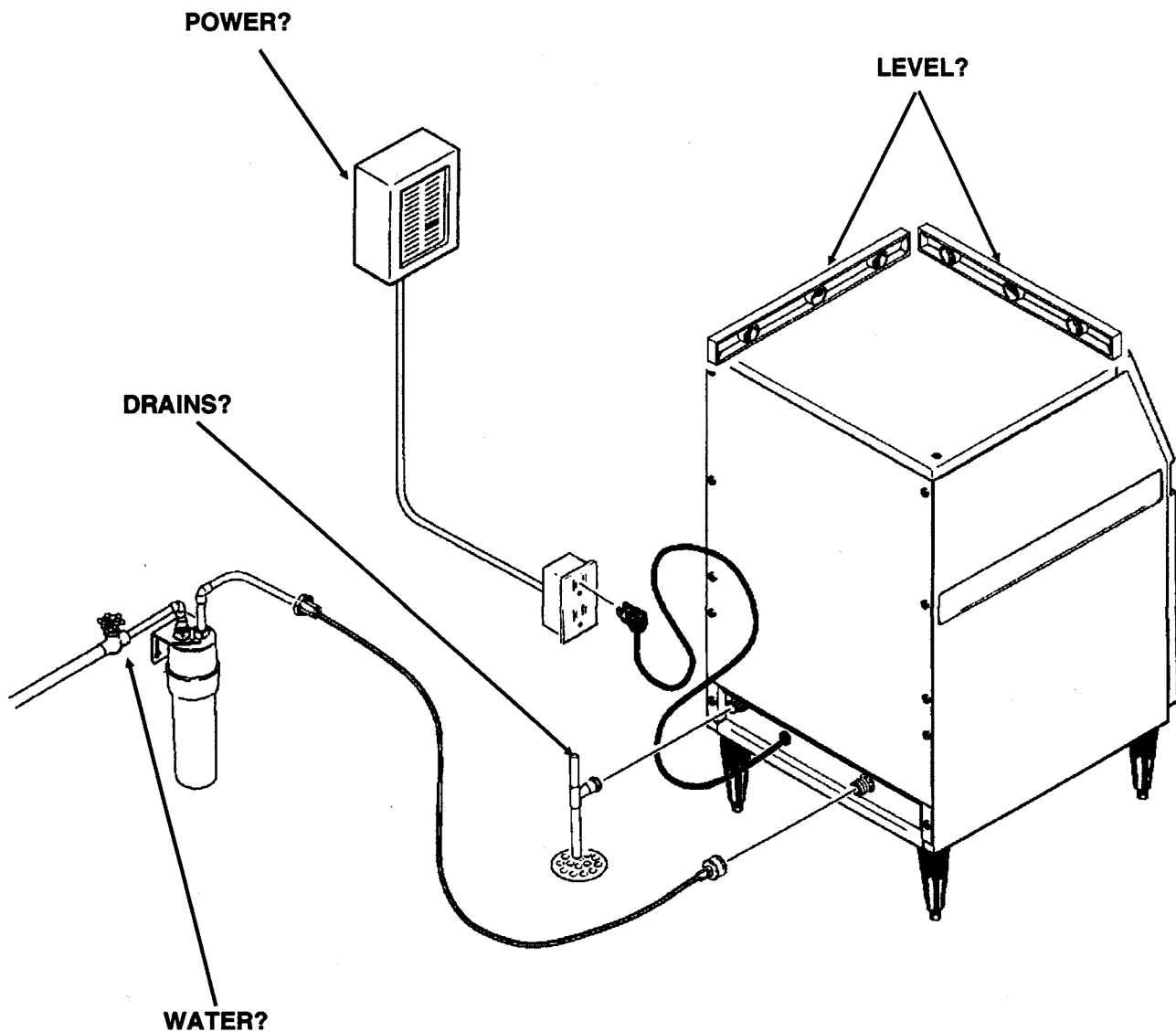

1. Open the water supply valve.
2. Move electrical breaker or switch to the **ON** position.
3. Remove the front panel.
4. Check the cube size control shaft, it should be in a preset position. If not, rotate the control shaft clockwise until the unit comes on.
Note: Cube size adjustments may be required. Start with the shaft in the “mid” position.
5. The machine will go through a “dry cycle”; this will take about 10 minutes. The water fill and harvest cycle will begin.
6. Observe the water fill cycle:
 - The water inlet valve opens.
 - Incoming water flows from the water valve through the tubing to the top of the icemaker.
 - Water flows around the inverted ice cube cups and drains through holes into the reservoir.
 - The reservoir begins to fill up with water.
 - Water continues to enter the machine and overflows a standpipe in the reservoir and down the drain. This will take about 3 ½ minutes. After that, the freeze cycle will begin.
7. Check the operation of the freezing cycle:
 - ✓ Compressor is running.
 - ✓ Water pump is spraying water through the spray nozzles.
 - ✓ Ice making begins, ice begins to form in the cube molds.
8. Check that the plastic curtain assembly hangs down evenly in the opening and that no large streams of water are passing through.
Note: Some water will drip from the reservoir as the machine runs, this is normal.
9. After about 20 minutes, the machine will begin to release ice. This is called the harvest cycle.
 - Observe the first cube harvest:
 - ✓ Check the size of the ice cubes.
Note: The normal size of the ice cube has a ¼ inch depression in the wide end.
If the cubes are not filled out, adjust the machine to make larger ice cubes by turning the cube size control shaft clockwise.
If the cubes are overfilled, adjust the machine to make smaller ice cubes by turning the cube size control counter-clockwise.
In both cases, the next cycle of cubes harvested must be observed, and further corrections may be needed.
If the ice cubes are cloudy, an extreme water condition may exist. Confirm that they are cloudy by placing them in a glass of cold water. If, in the water, they remain cloudy, you may want to have the water tested by a water treatment specialist. If the cubes are cloudy only on the bottom or in the center of the cube, the machine may be running out of water before the end of the freeze cycle.
10. Test the bin full shut off. To test this, hold some ice on the bin thermostat bracket (the stainless steel tube in the left-hand side of the ice storage bin). The icemaker should stop within a few minutes of having ice on that tube.
11. Fill out the Warranty Registration and Customer Evaluation form, and mail both to Ice-O-Matic.
12. Make sure the user understands the operation and maintenance requirements for the icemaker. Leave the service manual and name of the local Ice-O-Matic service agency with the user.

Component Description

Cube Size Control

The Cube size control is located in the front of the control box, behind the front panel. The sensing capillary tube of the cube size control is routed out of the control box into its bulb holder on the evaporator coil. It is a reverse acting temperature control with double throw contacts. Turning its knob all the way counterclockwise also shuts off the icemaker.

Compressor Toggle Switch

The compressor toggle switch is located on the side of the control box. When moved to the **ON** position, it makes a circuit to the compressor. When moved to the **OFF** position, the other components will still operate.

Water Pump

The water pump operates during the freezing cycle only, pumping water through the spray nozzles into the inverted spray cups.

Inlet Water Solenoid Valve

The water solenoid valve, located in the back panel of the unit, is energized only during the harvest or cleaning cycles. When energized, it allows a metered amount of water to flow into the machine (.21 GPM). This water flows to the top of the evaporator and then down into the reservoir.

Bin Thermostat Control

The bin thermostat control body is located in front of the control box just beside the cube size control. The thermostat sensing tube is located in the ice storage bin on the left side wall and will automatically shut the icemaker off when the bin is full and restart when ice is removed. Factory settings are 36° F cut out and 39° F cut in. It can be adjusted by turning the adjustment screw visible through the control box cover.

Hot Gas Valve Assembly

The hot gas valve assembly is comprised of two components, the valve body and the coil. These components are located on the discharge line of the compressor and are activated by the cube size control (harvest cycle). When the coil of the hot gas valve is energized, it magnetically lifts the plunger in the hot gas valve body. This allows hot refrigerant gas to by-pass the condenser and go directly to the evaporator.

Spray Platform and Chute

The spray system used on this unit is of the stationary type. The water is forced by the water pump into the platform chamber and sprayed into the inverted cup molds through a set of six spray nozzles.

Fan Motor

The fan motor is electrically connected through the cube size control and runs only during the freeze cycle.

Hermetic Motor Compressor

The compressor is a vapor pump, forcing refrigerant gas throughout the refrigeration system.

Reference Page 8 for Component Location.

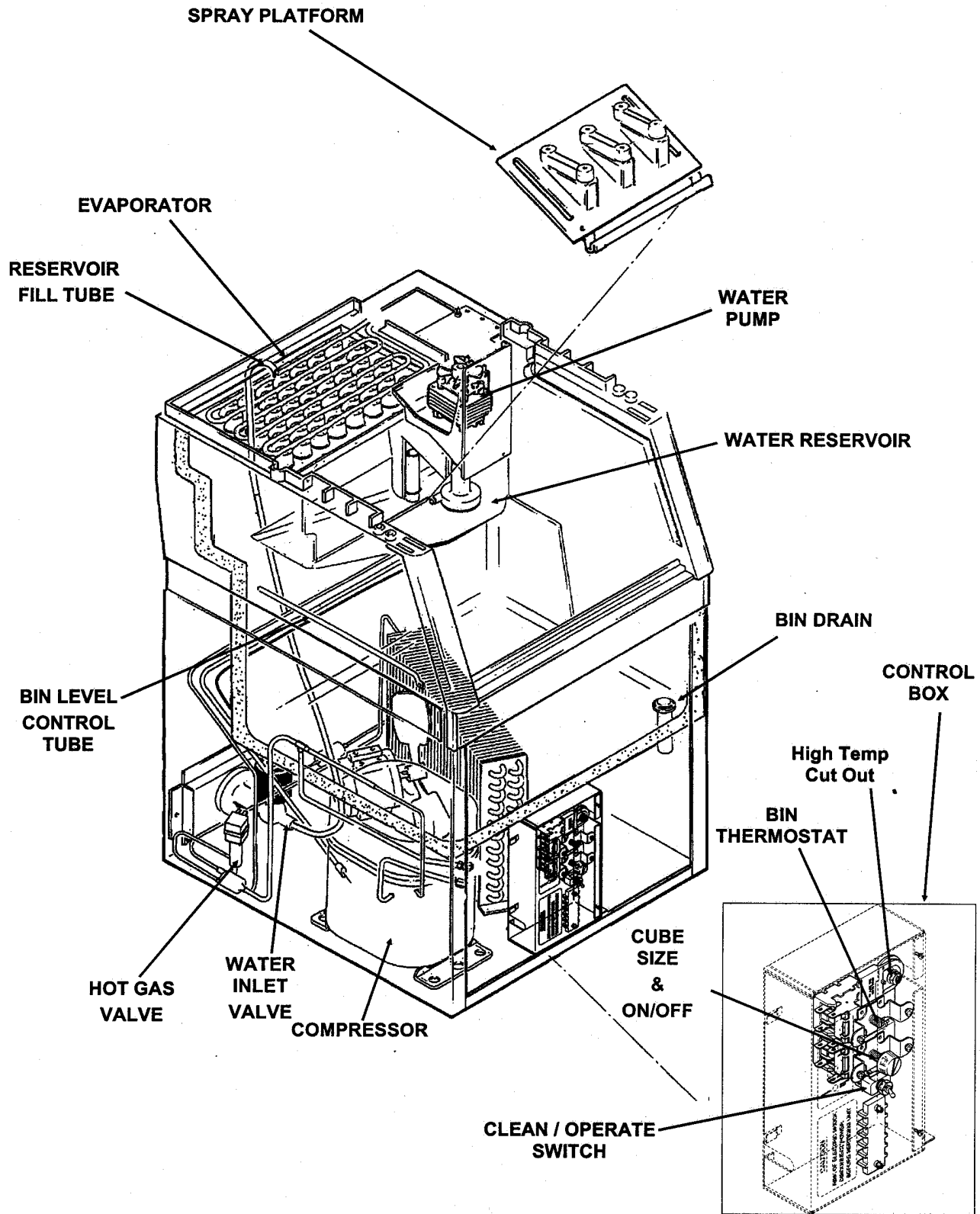

Water System

Freezing Cycle

The refrigeration process creates cold temperatures within the evaporator coils and removes heat from the water sprayed up into the inverted ice cube cups. When enough heat is removed, the water changes into ice, and forms where it is the coldest: in the ice cube cups.

Minerals contained in the supply water will not freeze and are drained away. Mostly pure water will be frozen into the ice cubes.

During the freezing cycle, the compressor, fan motor, and water pump are operating. Water is continuously freezing or being sprayed and recirculated. When the evaporator temperature is lowered to the cold temperature setting of the cube size control, it ends the freezing cycle and starts the harvest cycle.

Harvest Cycle

The hot gas valve opens and hot refrigerant gas is discharged into the evaporator. The inlet opens and a fresh supply of water flows to the top of the evaporator and then drains into the reservoir.

The ice cubes have been released from the inverted cube cups in the evaporator by the warming effect of the hot refrigerant gas condensing in the evaporator tubing, plus the incoming water flowing around the inverted cups. The released ice cubes drop onto the spray platform and through the curtain assembly into the ice storage bin.

The cube size control thermostat senses the warmer temperatures of the harvest cycle, and at a preset temperature, opens the circuit to the hot gas and inlet water valves. Both valves then close.

The harvest cycle is complete, and the freezing cycle restarts.

The automatic ice making process continues until the bin is full of ice, and the bin thermostat senses a colder temperature.

The bin thermostat then opens the circuit to all components and the automatic ice making process stops.

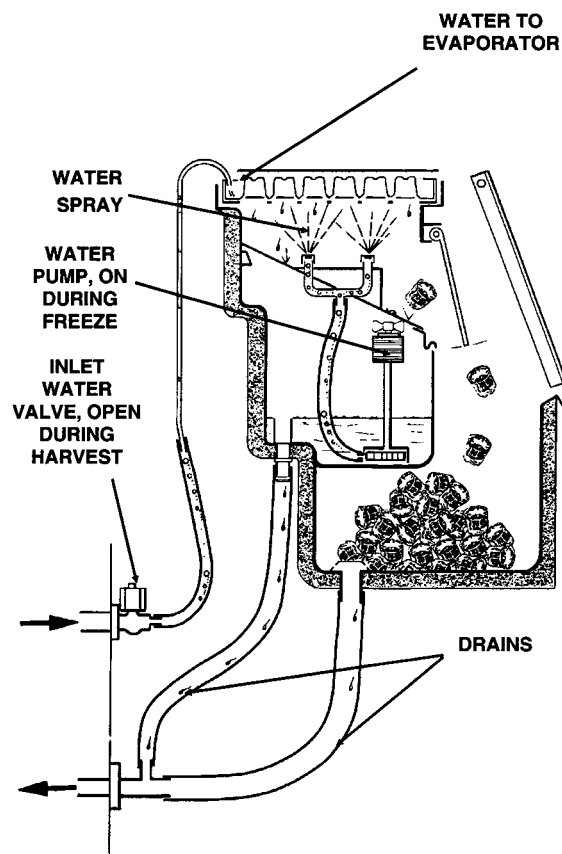

Refrigeration System

Freezing Cycle

The ice cubes are formed in an inverted mold that is refrigerated.

The refrigeration process begins at the **compressor**. There, refrigerant vapor is compressed and flows from the compressor through the **discharge line** as a high temperature, high pressure gas. In the discharge line there is a **strainer** with two outlets; one leads to the **condenser**, and the other one to the **hot gas valve**. Because the hot gas solenoid is closed, the gas flows to the condenser, where heat is transferred from the refrigerant to the air passing through the condenser. The refrigerant then condenses into a high pressure liquid.

From the condenser, the liquid refrigerant flows through the **liquid line**, and the liquid line **filter drier**. After the filter drier, the liquid refrigerant enters the metering device, a **capillary tube**. After passing the restriction of the capillary tube, the refrigerant enters an area of relative low pressure, the **evaporator**. In the tubing of the evaporator, the liquid refrigerant expands and evaporates, absorbing heat from the evaporator tubing and anything in contact with it such as water sprayed against it.

The refrigerant, now a low pressure, low temperature vapor, flows into the **accumulator**, which traps excess liquid refrigerant. The vapor, now primarily a gas, goes through the **suction line** and back to the compressor.

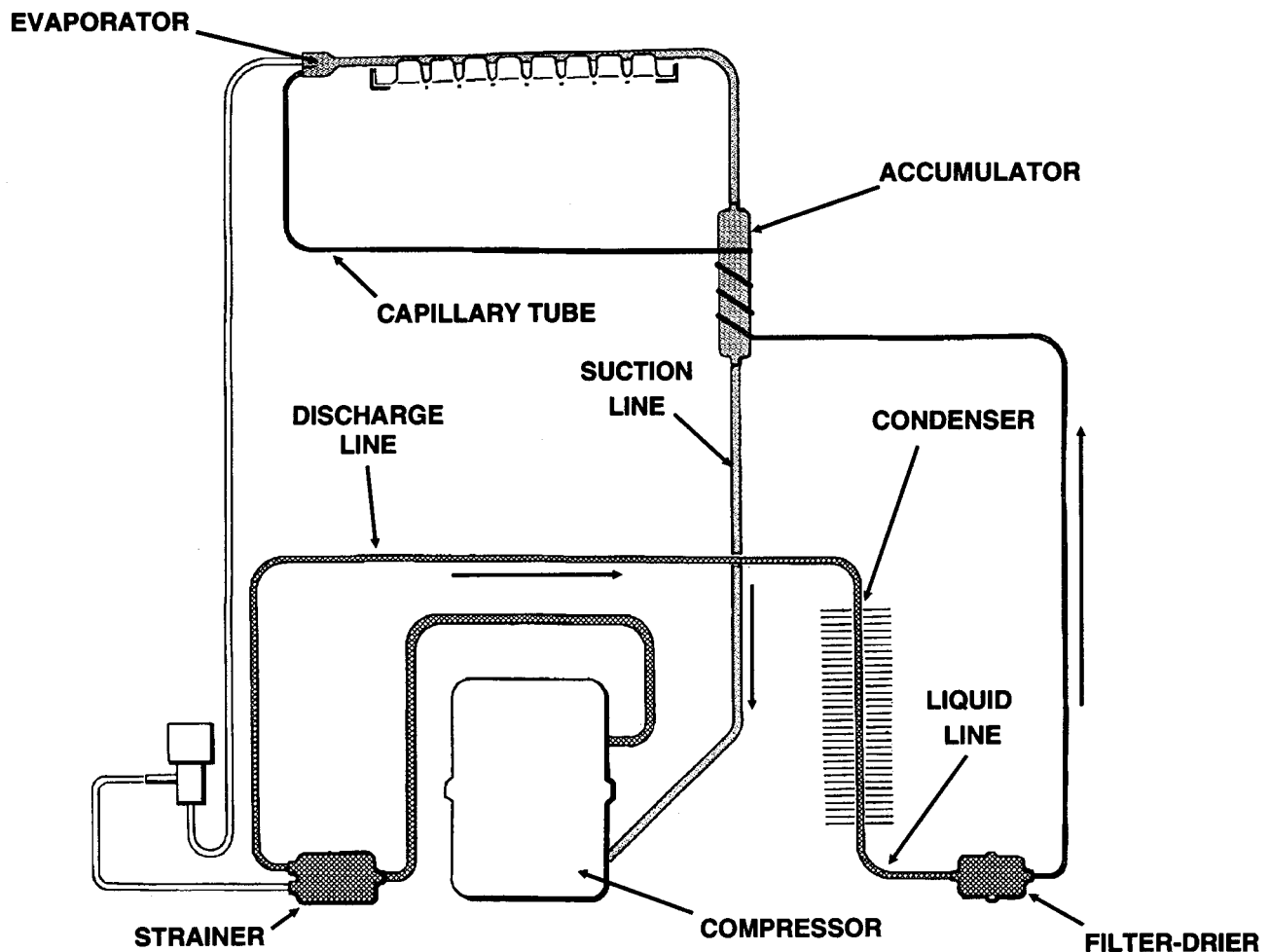

Refrigeration System

Harvest Cycle

(When the cubes are released)

The ice cubes have been formed in an inverted mold that was refrigerated. Now the refrigeration system will change to warm the cube mold and release the cubes.

The process begins at the **compressor**. There, refrigerant vapor is compressed and flows from the compressor through the discharge line as a high temperature, high pressure gas. Before the gas gets to the condenser, it goes through a **strainer**. The strainer outlet is connected to two tubes, one which leads to a **hot gas valve solenoid**. When this valve opens, the refrigerant gas follows the path of least resistance and flows through the tubing from the hot gas valve to the **evaporator**, where the ice cubes are frozen.

At the evaporator, the high temperature gases are cooled by the cold temperatures of the cube mold, and condense onto liquid, transferring heat to the mold which warms up and releases the cubes. The refrigerant, now a low pressure, low temperature vapor, flows into the **accumulator**, which traps excess liquid refrigerant. The vapor, now primarily a gas, goes through the **suction line** tube to the compressor where the cycle is repeated.

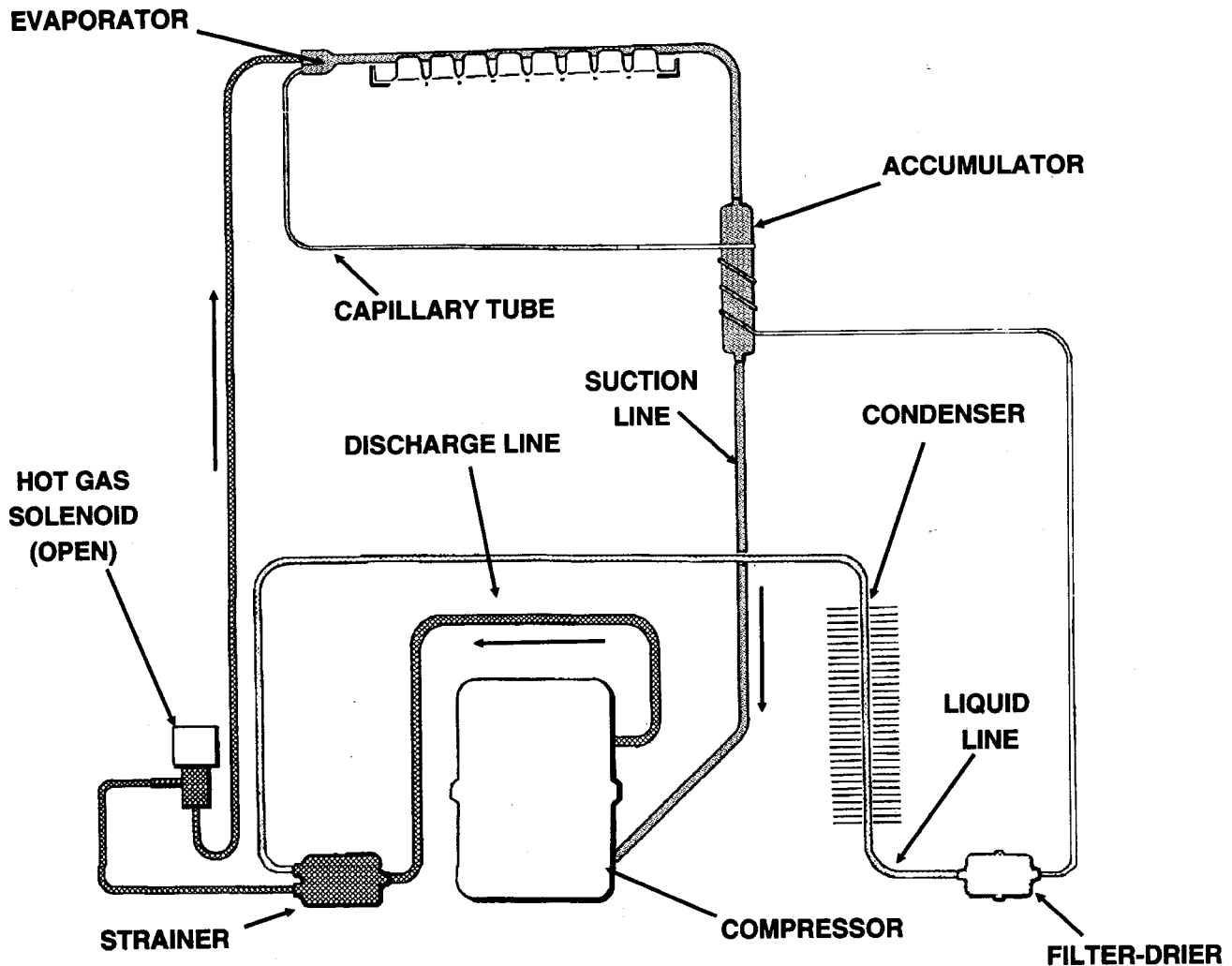

The information shown below covers a wide range of air and water temperatures. It is intended as a guideline only, and is based on data compiled from NEW Clean units. Allow a variation from each end of the range given.

Refrigeration System Pressures:

High Side (Discharge)	
End of Freeze Cycle	125-130 PSI
Harvest Cycle	83-125 PSI
Low Side (Suction)	
End of Freeze Cycle	1-3 PSI
Harvest Cycle (Max)	120 PSI

Freeze Cycle Time - 20-25 Minutes

Defrost Cycle Time – 2-3 Minutes

Compressor Amps

Freeze Cycle – 3.6 to 4.3

Harvest Cycle – 3.6 to 7.7

Adjustment Of The Cube Size

Adjust only when cubes are too large or too small.

(See the illustration at the right)

1. Remove the front panel, locate knob.
2. To increase the cube size, turn knob 1/8 turn clockwise. To decrease the cube size, turn the knob 1/8 turn counter clockwise.
3. Observe the size of the cubes in the next two harvest cycles. If more adjustment is needed, continue adjustments until the correct size is obtained.

Adjustment Of The Bin Thermostat Control

Adjust the bin thermostat when the icemaker turn off too soon (ice level low) or when it turns off too late (ice storage bin overfills.)

To increase the ice level in the storage bin:

1. Rotate the bin thermostat adjustment screw (located under the front panel on the control box cover) clockwise 1/8 turn at a time until the ice level that the machine maintains is correct.
2. Rotate the bin thermostat adjustment screw counterclockwise 1/8 turn at a time until the ice level is correct.

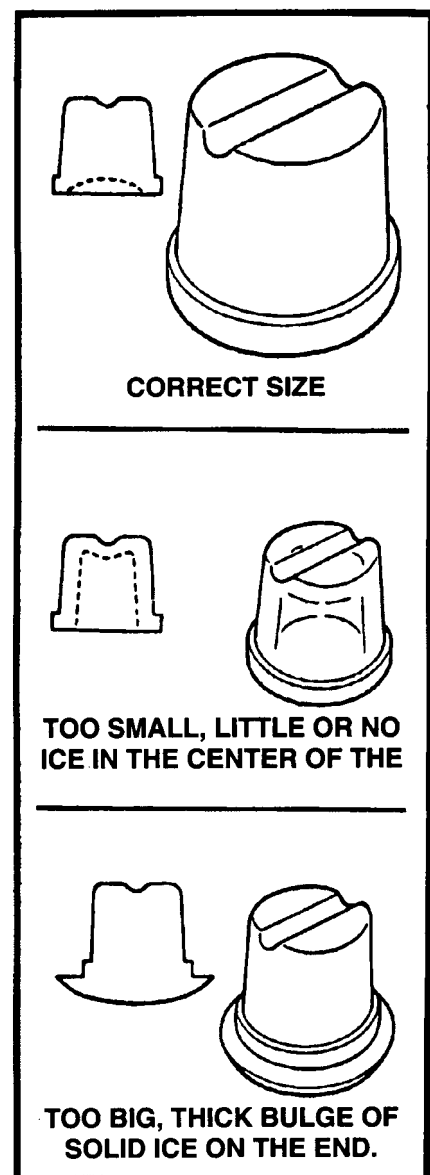

An Ice-O-Matic ice machine represents a sizable investment of time and money in any company's business. In order to receive the best return for that investment, it **MUST** receive periodic maintenance. It is the **USER'S RESPONSIBILITY** to see that the unit is properly maintained. The following is a list of recommended maintenance that will help keep the machine running with a minimum of problems. Maintenance and cleaning should be scheduled at least every six (6) months.

General

The periods and procedures for maintenance are provided as a guide. Cleaning will vary depending upon local water conditions and amount of ice used. Each ice maker must be maintained individually, in accordance with its own requirements.

Icemaker In Place Cleaning

1. Remove the ice from the bin.
 2. Remove the front panel.
 3. Rotate the control knob counterclockwise to the **OFF** position.
 4. Remove the curtain by pulling forward on the left end, and then pulling the curtain to the left and out of the machine.
 5. Lift up spray platform, locate the stand pipe to the right of the opening, and pull it out to drain the reservoir. Replace the stand pipe, spray platform, and curtain.
 6. Mix approximately 3 ounces of approved ice machine cleaner with 1.5 quarts of warm (95°F-115°F) potable water, and pour this solution into the reservoir at the curtain base.
- ⚠ WARNING** Ice machine cleaner contains acids. These compounds may cause burns. If swallowed DO NOT induce vomiting. Give large amounts of water or milk. Call Physician immediately. In case of external contact, flush with water.

7. Rotate the control knob the **“normal”** position. Operate the machine for 20 minutes.
 8. Then switch the toggle switch to the **“cleaning position”** for about three minutes to release all the cubes from their cups.
 9. Switch the cleaning toggle switch to the **“operation”** position, and allow the machine to run for 30 minutes, or until the next batch of ice is released.
10. Pour hot water into the bin to melt the ice produced during cleaning, and to clean out the drain. Wipe the interior of the bin with mild soap and hot water, rinse with cold water. To sanitize, prepare ½ ounce of approved (EPA/FDA) sodium hypochloride food equipment sanitizer to 1 gallon of warm water to form a solution with 100 minimum to 200 maximum ppm free chlorine yield, and repeat steps 3-10, except substitute the sanitizer solution for the ice machine cleaner solution.
 11. Replace the front panel

Ice Maker Maintenance

1. Shut off water supply to the icemaker.
2. Disconnect the water inlet tube from the connection at the back of the icemaker, and check the screen at that point. If very dirty, carefully pull the screen out and clean it. Reassemble the water line to the icemaker.
3. Open the water shutoff valve.
4. Unplug the power cord to disconnect electrical power to the icemaker.
5. Remove the front panel.
6. Clean the air-cooled condenser fins using a brush or vacuum cleaner, or if needed, coil cleaner. A dirty condenser coil reduces the ice making capacity of this machine.

SYMPTOM	POSSIBLE CAUSE	SUGGESTED CORRECTION
Unit will not run.	Blown fuse or breaker.	Replace fuse and check for cause of blown fuse or breaker.
Compressor cycles intermittently.	Low voltage. Dirty condenser. Restricted air circulation. Non condensibles in system.	Check voltage at the supply to the building. Check circuit for overloading. Clean the condenser. Allow sufficient air circulation. Evacuate and recharge with name plate Amount.
Cubes too small.	Cube size control too warm. Partially restricted cap tube. Moisture in system. Overcharged. Undercharged.	Check and adjust for operation. Recover charge, install new drier, evacuate, weigh in new charge. Same as above. Same as above. Same as above. Check for leak.
Cloudy cubes.	Spray nozzle clogged. Needs cleaning.	Clean. Clean with approved ice machine cleaner.
Irregular size cubes, Some cloudy. Cubes too large.	Some jets plugged. Shortage of water. Cube size control adjusted improperly.	Clean jets. Check water supply. Check and adjust for proper operation.
Decreased ice capacity.	Inefficient compressor.	Replace compressor.
Low ice capacity.	Leaky inlet water valve. Non condensibles in system. High head pressure. High air or water temperatures. Overcharged. Restricted system.	Replace water valve. Replace the refrigerant. Dirty condenser. Worn fan motor. High air or water temperatures. Relocate machine or water line. Replace the refrigerant. Replace the drier and refrigerant.
Poor harvest. No harvest.	Short defrost cycle. Not enough water. Hot gas valve does not work. Inlet water valve plugged. Air and water temperature too low. Cube size control does not work. Hot gas valve does not work. Inlet water valve does not work.	Replace the cube size control. Check water supply. Replace hot gas valve. Replace inlet water valve. Relocate machine or water line. Replace cube size control. Replace hot gas valve. Replace inlet water valve.
Excessive water in ice storage bin.	Bin drain plugged.	Clean bin drain.

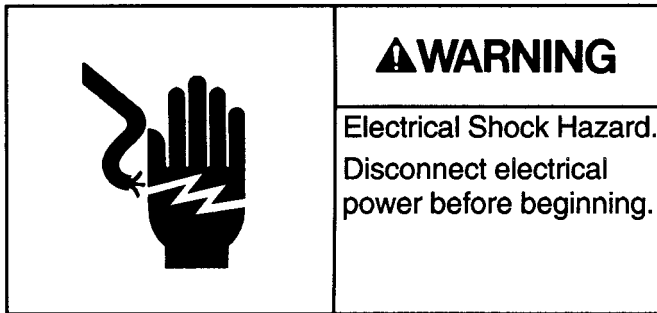

Bin Thermostat

1. Unplug the icemaker to disconnect electrical power.
2. Remove screws and cabinet front panel.
3. Remove screws and the control box cover, disconnect electrical wires from the bin thermostat control.
4. Dismount the bin thermostat from the control box.
5. Remove the rear panel.
6. Pull the bin thermostat capillary line from the tube in the ice storage bin. Remove complete control from ice machine.
7. Replace with a new control in reverse order of removal.

Cube Size Control

1. Unplug the icemaker to disconnect electrical power.
2. Remove screws and cabinet top, front and rear panels.
3. Pull knob from the cube size control shaft. Remove screws and control box cover to gain access to the cube size control body. Remove screws and dismount the cube size control from the control box. Disconnect the electrical wires from the cube size control.

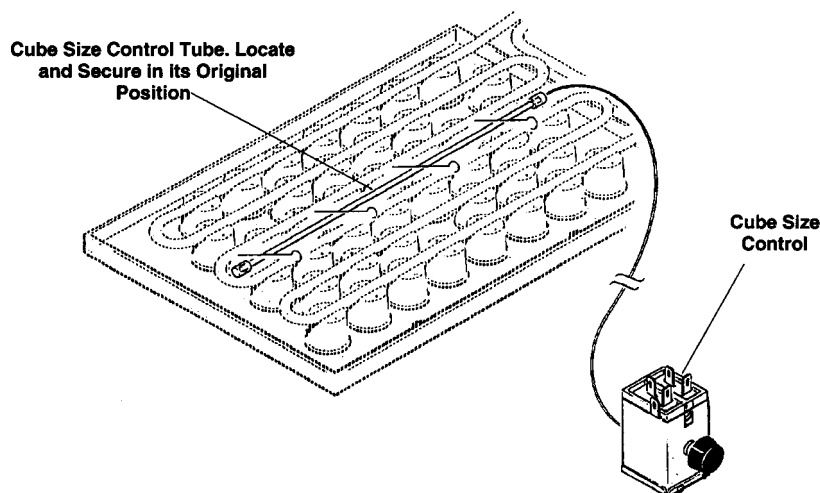

4. At the top of the machine, unclip the cube size thermostat tube holder from the evaporator (retain the clips and tube assembly). Pull the cube size control capillary tube from the tube holder, and remove the complete cube size control from the icemaker.
5. Insert new cube size control capillary tube into the tube holder, (insure that the end caps are in place).
6. Reverse the removal procedures to reinstall the cube size control. Adjust as necessary.

Refrigeration System

Any time the refrigeration system is opened, the drier must be replaced, the system evacuated and the exact charge measured into the system. Any other procedure is incorrect and will result in substandard performance.

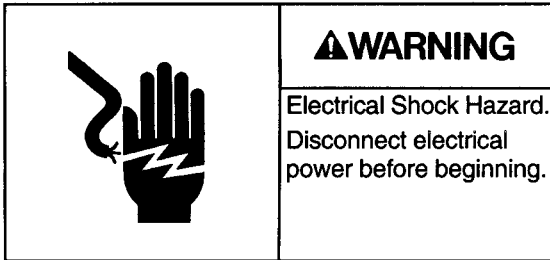

Spray Platform

1. Unplug the icemaker to disconnect electrical power.
2. Open ice bin door.
3. Pull out on the left side and remove curtain assembly.
4. Lift the spray platform up and pull out to get to the water hose at the base of the platform.
5. Pull hose off of connection to spray platform, and pull platform from the icemaker.
6. To replace, reverse the removal procedures.

Inlet Water Valve

1. Unplug the icemaker to disconnect electrical power.
2. Shut off water supply to icemaker.
3. Remove the lower back panel, pull out to expose inlet water valve.
4. Disconnect electrical wires from the inlet water valve.
5. Disconnect water lines to and from the water valve
6. Remove the valve from the icemaker.
7. Reverse removal procedure to replace.

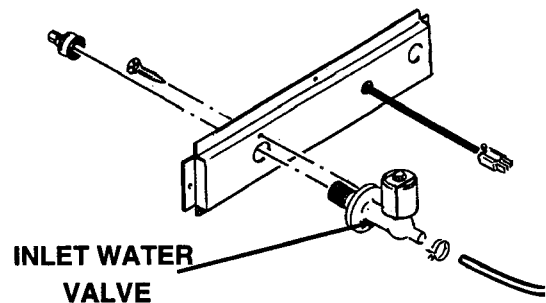

Water Pump

1. Disconnect the electrical wires from the cube size control.
2. Remove the top panel,
3. Open ice bin door, pull up from the top and remove.
4. Remove curtain by pulling forward and out on the left end.
5. Remove 2 screws holding pump bracket to right side panel.
6. Disconnect 2 electrical leads and 1 ground wire from the pump.
7. Pull out spray platform, lift pump and disconnect hose.
8. Pull water pump up and out of icemaker.
9. Dismount water pump from cover assembly (retaining brackets), and remount the replacement pump in its place.
10. Reverse removal procedures to replace.

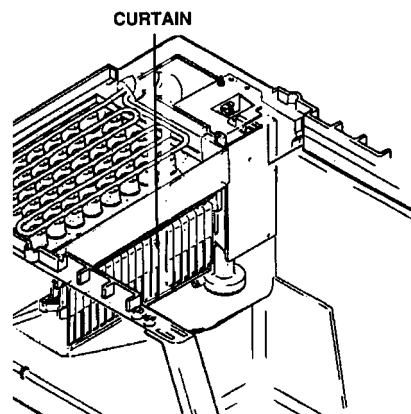

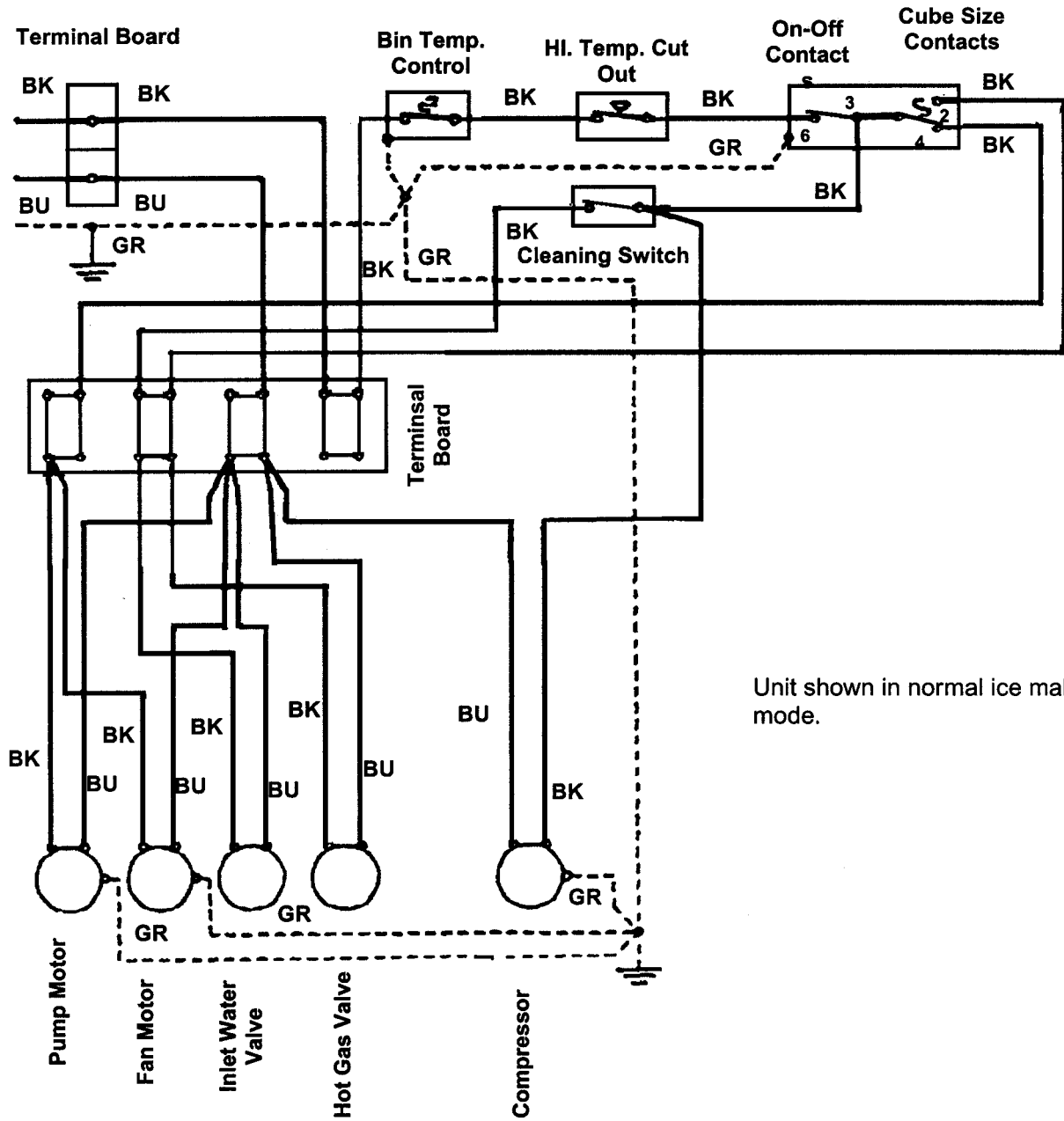

Unit shown in normal ice making mode.

