



Reliability is a
beautiful thing™

HOSHIZAKI®

CUBELET ICE DISPENSER

MODEL

DCM-270BAH-OS

SERVICE MANUAL



ITEM #: 73110
ISSUED: February 10, 2004
REVISED: May 26, 2005

IMPORTANT

Only qualified service technicians should attempt to service or maintain this ice dispenser. No service or maintenance should be undertaken until the technician has thoroughly read this service manual.

HOSHIZAKI provides this manual primarily to assist qualified service technicians in the service and maintenance of the dispenser.

Should the reader have any questions or concerns which have not been satisfactorily addressed, please call or write to the HOSHIZAKI Technical Support Department for assistance.

HOSHIZAKI provides this manual primarily to assist qualified service technicians in the service and maintenance of the dispenser.

Should the reader have any questions or concerns which have not been satisfactorily addressed, please call or write to the HOSHIZAKI Technical Support Department for assistance.

HOSHIZAKI AMERICA, INC.
618 Highway 74 South
Peachtree City, GA 30269

Attn: HOSHIZAKI Technical Support Department

Phone: 1-800-233-1940 Technical Service
(770) 487-2331
Fax: (770) 487-3360

Web Site: www.hoshizakiamerica.com

NOTE: To expedite assistance, all correspondence/communication **MUST** include the following information:

- Model Number
- Serial Number
- Complete and detailed explanation of the problem

Please review this manual. It should be read carefully before the ice dispenser is serviced or maintenance operations performed. Only qualified service technicians should service and maintain the dispenser. This manual should be made available to the technician prior to service or maintenance.

CONTENTS

I. Specifications	4
1. DCM-270BAH-OS (air-cooled)	4
II. General Information	5
1. Construction	5
2. Operation - How it works	6
III. Technical Information	7
1. Water Circuit and Refrigerant Circuit.....	7
2. Performance Data	8
[a] DCM-270BAH-OS (air-cooled)	8
3. Wiring Diagram	9
4. Sequence of Electrical Circuit	10
IV. Service Diagnosis	20
1. No Ice Production	20
2. Low Ice Production	22
3. Faulty Dispenser.....	23
[a] Optical Sensor Description	23
4. Other	25
V. Removal and Replacement of Components	26
1. Service for Refrigerant Lines	26
[a] Refrigerant Recovery	26
[b] Evacuation and Recharge [R-404A]	26
2. Brazing	27
3. Removal and Replacement of Compressor	28
4. Removal and Replacement of Drier	29
5. Removal and Replacement of Thermostatic Expansion Valve	30
6. Removal and Replacement of Pressure Switch	31
7. Removal and Replacement of Control Water Valve	32
8. Removal and Replacement of Flush Water Valve	33
9. Removal and Replacement of Float Switch.....	34
10. Removal and Replacement of Bin Control Switch Assembly	35
11. Removal and Replacement of Storage Bin Assembly	36
12. Removal and Replacement of Agitator and Drip Ring	37
13. Removal and Replacement of Evaporator Assembly	38
VI. Cleaning and Maintenance Instructions	41
1. Preparing the Ice Dispenser for Long Storage	41
2. Cleaning Instructions	42
[a] Cleaning Procedure	42
[b] Sanitizing Procedure	45
2. Maintenance Instructions	46

I. Specifications

1. DCM-270BAH-OS (air-cooled)

AC SUPPLY VOLTAGE	115/60/1		
AMPERAGE	8.5 A [AT 104°F(40°C)/WT 80°F(27°C)]		
MAXIMUM FUSE SIZE	N/A		
MINIMUM CIRCUIT AMPACITY	N/A		
APPROXIMATE ICE PRODUCTION PER 24 HR.	Ambient Temp.(°F)	WATER TEMP. (°F)	
lbs./day (kg/day)		50	70
Reference without *marks		90	
	70	* 288 (131)	276 (125)
	80	254 (115)	243 (110)
	90	224 (101)	* 220 (100)
	100	197 (89)	* 176 (80)
SHAPE OF ICE	Cubelet (Compressed Flake Ice)		
ICE QUALITY	Approx. 90%, Ice (90/70°F, Conductivity 200 µs/cm)		
APPROXIMATE STORAGE CAPACITY	8.8 lbs.		
ELECTRIC & WATER CONSUMPTION	90/70°F	70/50°F	
ELECTRIC W (kWH/100 lbs.)	669 (7.3)	638 (5.3)	
POTABLE WATER	26 (12)	35 (12)	
gal./24HR (gal./100 lbs.)			
EXTERIOR DIMENSIONS (WxDxH)	16-9/16" x 24-1/8" x 31-11/16" (420 x 613 x 805mm)		
EXTERIOR FINISH	Stainless Steel		
WEIGHT	Net 152 lbs. (69 kg), Shipping 170 lbs. (77kg)		
CONNECTIONS - ELECTRIC	Cord Connection		
- WATER SUPPLY	Inlet 1/2" FPT		
- DRAIN	Outlet 3/4" FPT		
ICE MAKING SYSTEM	Auger type		
HARVESTING SYSTEM	Direct Driven Auger (80W Gear Motor)		
ICE MAKING WATER CONTROL	Float Switch		
COOLING WATER CONTROL	N/A		
DISPENSER CONTROL SYSTEM	Photoelectric Sensor (Infrared)		
BIN CONTROL SYSTEM	Mechanical Bin Control (Proximity Sw.)		
COMPRESSOR	Hermetic, Model ASE24C3E		
CONDENSER	Air-cooled, Fin and Tube Type		
EVAPORATOR	Copper Tube on Cylinder		
REFRIGERANT CONTROL	Thermostatic Expansion Valve		
REFRIGERANT CHARGE	R-404A, 14.8 oz. (420 g)		
DESIGN PRESSURE	High 460 PSIG, Low 290 PSIG		
COMPRESSOR PROTECTION	Auto-reset Overload Protector		
GEAR MOTOR PROTECTION	Manual reset Circuit Breaker		
REFRIGERANT CIRCUIT PROTECTION	Auto-reset High Pressure Control Switch		
LOW WATER PROTECTION	Float Switch and Timer		
ACCESSORIES - SUPPLIED	N/A		
OPERATING CONDITIONS	VOLTAGE RANGE	104 - 127 V	
	AMBIENT TEMP.	45 - 100° F	
	WATER SUPPLY TEMP.	45 - 90° F	
	WATER SUPPLY PRESSURE	10 - 113 PSIG	

We reserve the right to make changes in specifications and design without prior notice.

II. General Information

1. Construction

The Hoshizaki Cubelet Ice Dispenser, model DCM-270BAH-OS includes water supply, freezer, condensing, storage, dispensing and control assemblies.

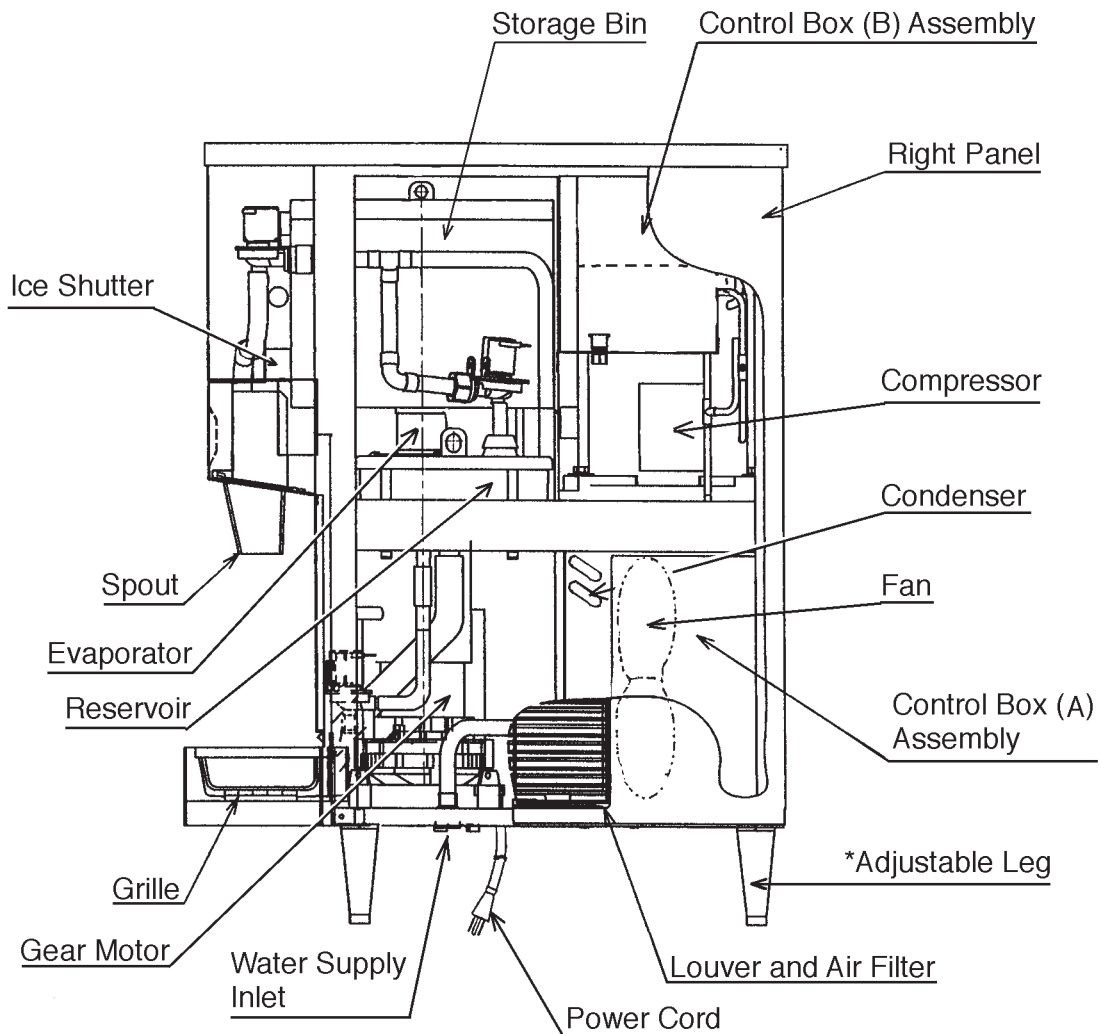

Fig. 1

Note: *Adjustable Legs

Minimum height - 4"

Maximum height - 5.3"

Do not adjust exceeding the above recommendation.

2.Operation - How it works

Water flows from the potable water source through the water supply line shut-off valve, enters at the water inlet fitting and into the water reservoir. The water reservoir functions to maintain a constant water level inside the freezer assembly. Water from the water reservoir enters at the bottom of the freezer. Heat is removed by the refrigeration process and ice forms inside the freezer.

A stainless steel auger, located inside the freezer, is direct-driven by the gear motor, and the rotating auger carries the ice upward to the end of the auger, where excess water is pressed out of the ice, as the ice is extruded and broken into cubelet ice (compressed ice) and then pushed out into the storage bin.

Moving the power switch on the bottom left of the middle front panel, to the “ON” position starts the automatic and continuous icemaking process. When the ice storage bin is filled with ice, the bin control switch will shut off the icemaking process. As the ice is removed from the storage bin, the bin control switch resets automatically and restarts the icemaking process.

The agitator in the storage bin keeps the ice from clustering so that the ice can move easily through the spout.

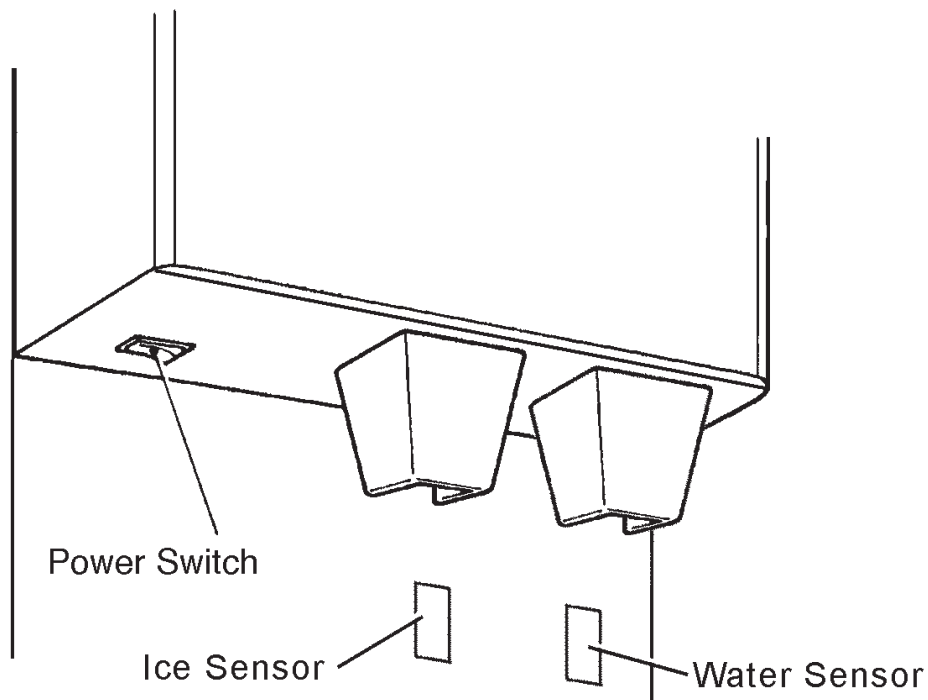
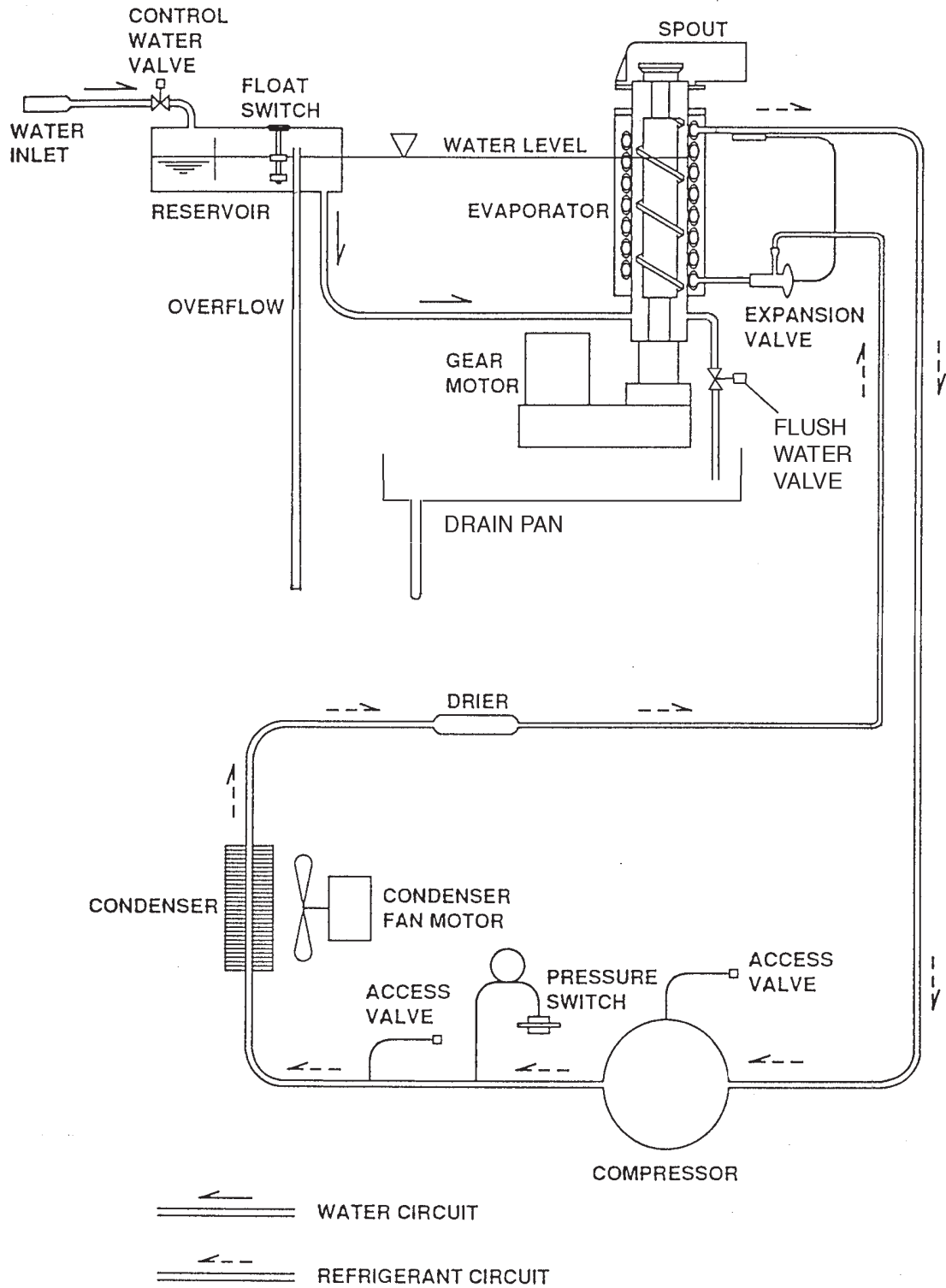

Fig. 2

III. Technical Information

1. Water Circuit and Refrigerant Circuit



2. Performance Data

[a] DCM-270BAH-OS (air-cooled)

APPROXIMATE ICE PRODUCTION PER 24 HR. lbs./day (l/day)	Ambient Temp. (F)	Water Temp. (F)					
		50		70		90	
	70	* 288	(131)	276	(125)	265	(120)
	80	254	(115)	243	(110)	233	(106)
	90	224	(101)	* 220	(100)	205	(93)
	100	197	(89)	189	(86)	* 176	(80)
APPROXIMATE ELECTRIC CONSUMPTION watts	70	* 639	--	669	--	689	--
	80	639	--	669	--	689	--
	90	639	--	* 669	--	689	--
	100	639	--	669	--	* 689	--
APPROXIMATE WATER CONSUMPTION PER 24 HR. (TOTAL) gal. / day (kl/day)	70	* 35	0.16	33	0.15	32	0.14
	80	30	0.14	29	0.13	28	0.13
	90	27	0.12	* 26	0.12	25	0.11
	100	24	0.11	23	0.10	* 21	0.10
EVAPORATOR OUTLET TEMP. °F (°C)	70	* 21	(6)	21	(6)	22	(6)
	80	22	(6)	25	(4)	25	(4)
	90	25	(4)	* 26	(4)	28	(2)
	100	28	(2)	28	(2)	* 28	(2)
HEAD PRESSURE PSIG (kg/cm ² G)	70	* 219	(15.4)	284	(19.9)	325	(22.8)
	80	219	(15.4)	284	(19.9)	325	(22.8)
	90	219	(15.4)	* 284	(19.9)	325	(22.8)
	100	219	(15.4)	284	(19.9)	* 325	(22.8)
SUCTION PRESSURE PSIG (kg/cm ² G)	70	* 37	(2.6)	42	(3.0)	46	(3.2)
	80	37	(2.6)	42	(3.0)	46	(3.2)
	90	37	(2.6)	* 42	(3.0)	46	(3.2)
	100	37	(2.6)	42	(3.0)	* 46	(3.2)
TOTAL HEAT OF REJECTION	3532 BTU/h (AT 90°F / WT 70°F)						

Note: Pressure data is recorded first 5 minutes in freezing cycle. The data without *marks should be used for reference.

We reserve the right to make changes in specifications and design without prior notice.

3. Wiring Diagram

WIRE COLOR CODE

BR	BROWN
BK	BLACK
DBU	DARK BLUE
LBU	LIGHT BLUE
GY	GRAY
O	ORANGE
P	PINK
R	RED
V	VIOLET
W	WHITE
Y	YELLOW
W/BK	WHITE/BLACK
W/BR	WHITE/BROWN
W/BU	WHITE/BLUE
W/O	WHITE/ORANGE
W/R	WHITE/RED

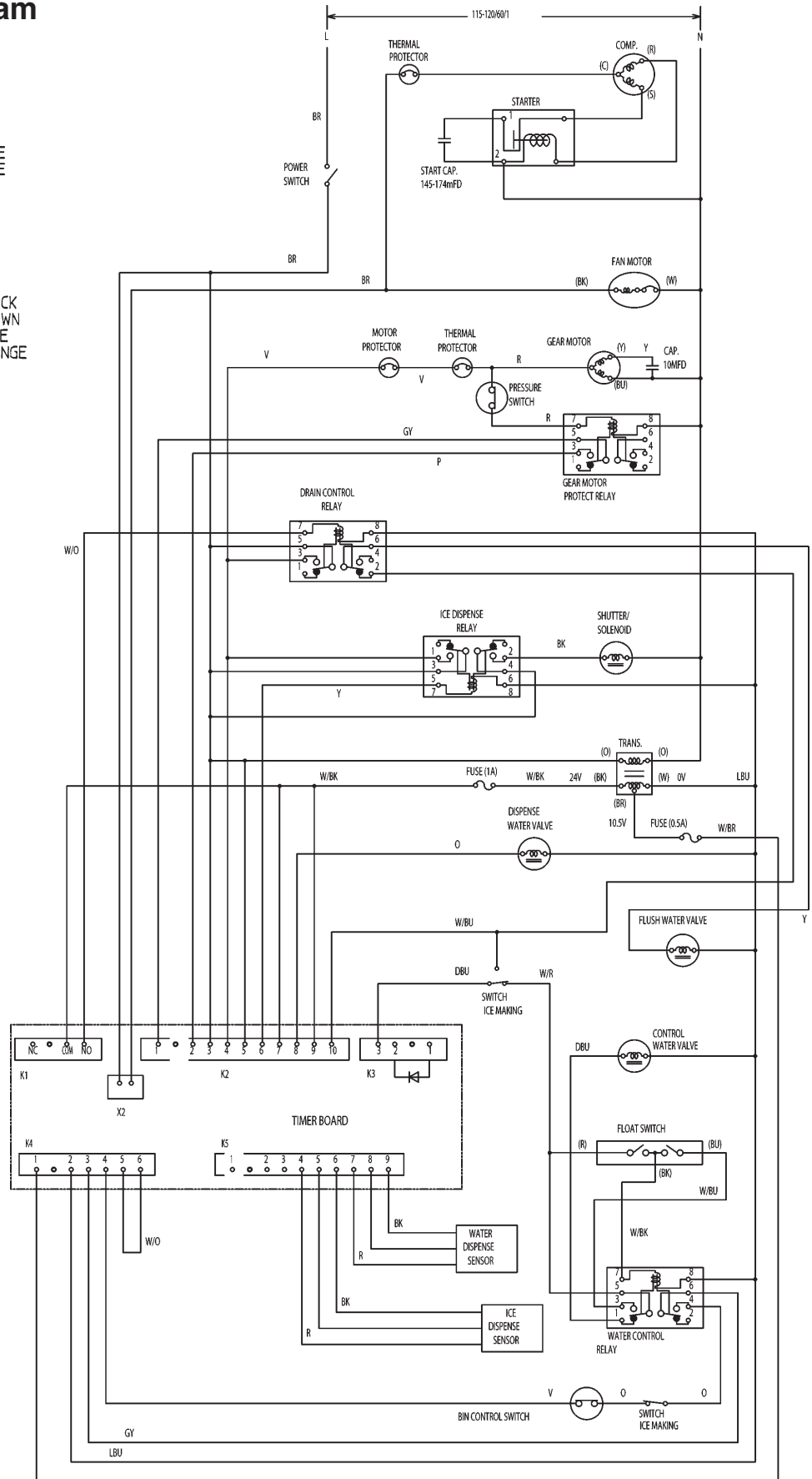

4. Sequence of Electrical Circuit

POWER ON

WATER STARTS TO BE SUPPLIED TO RESERVOIR

AGITATION TIMER ON - (2 SEC.)

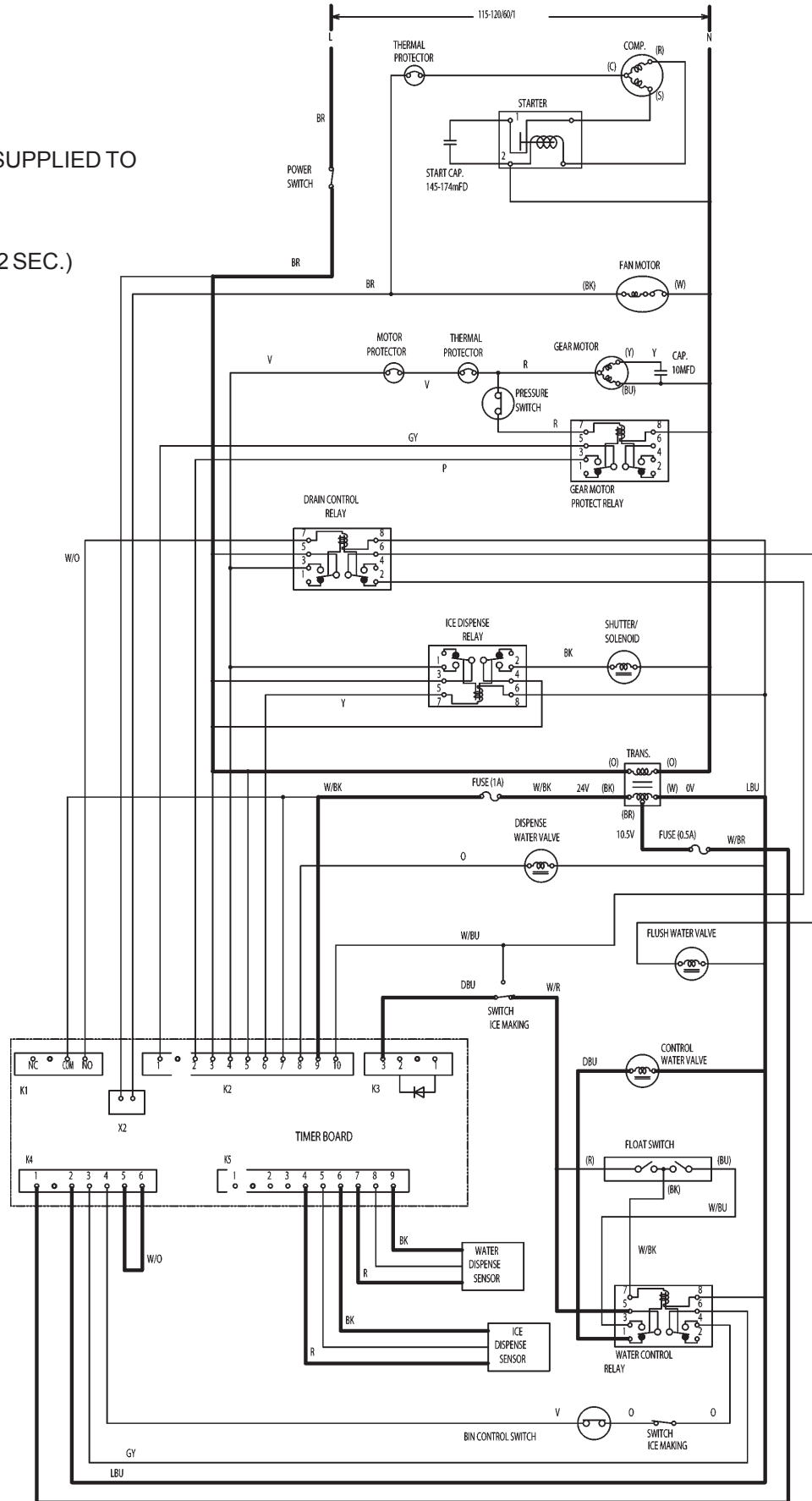

COMPRESSOR STARTS
60 SEC. AFTER GEAR MOTOR.

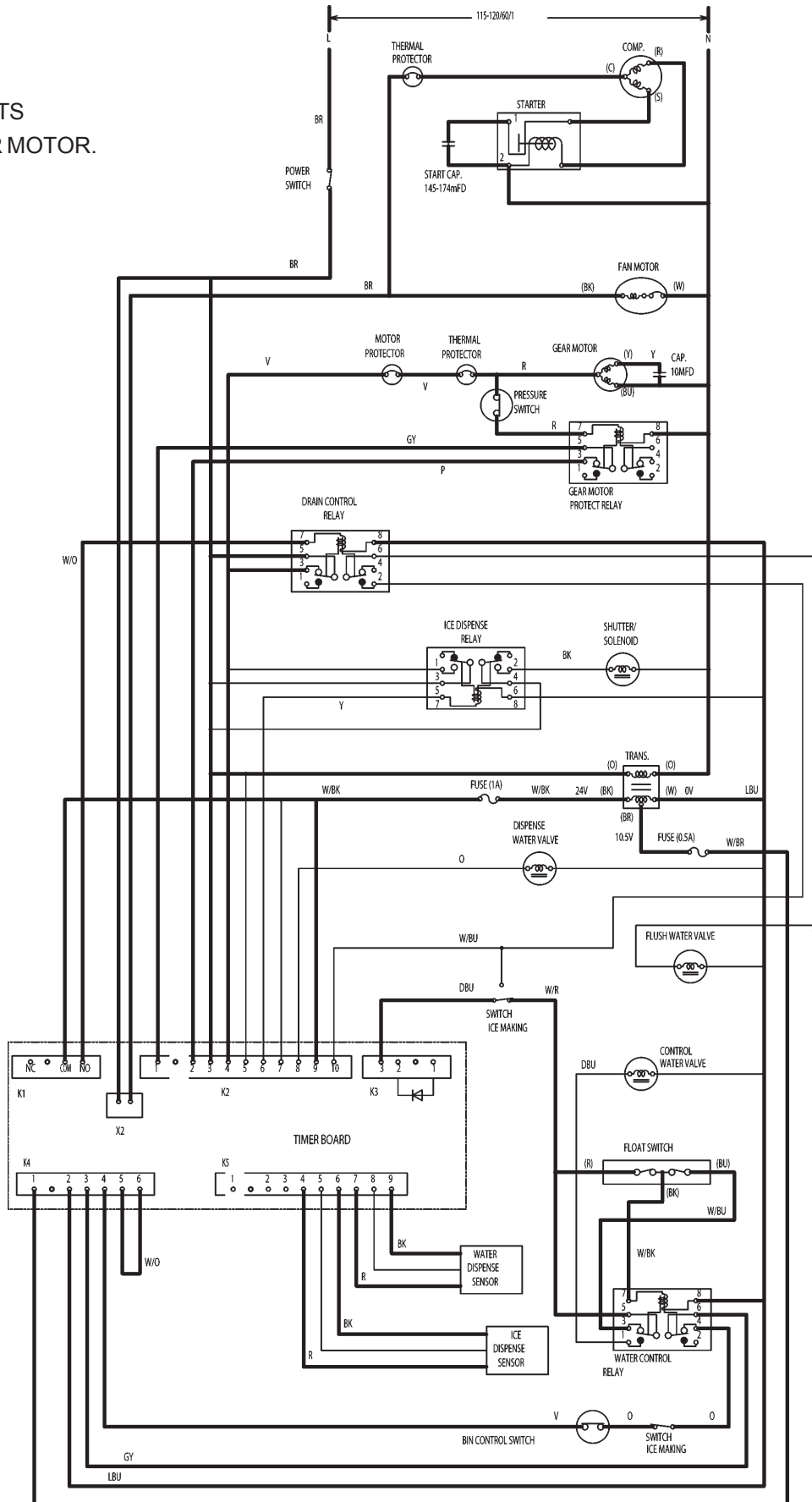

ICE MAKING CONTINUES.

START CAPACITOR TAKEN
OUT OF CIRCUIT

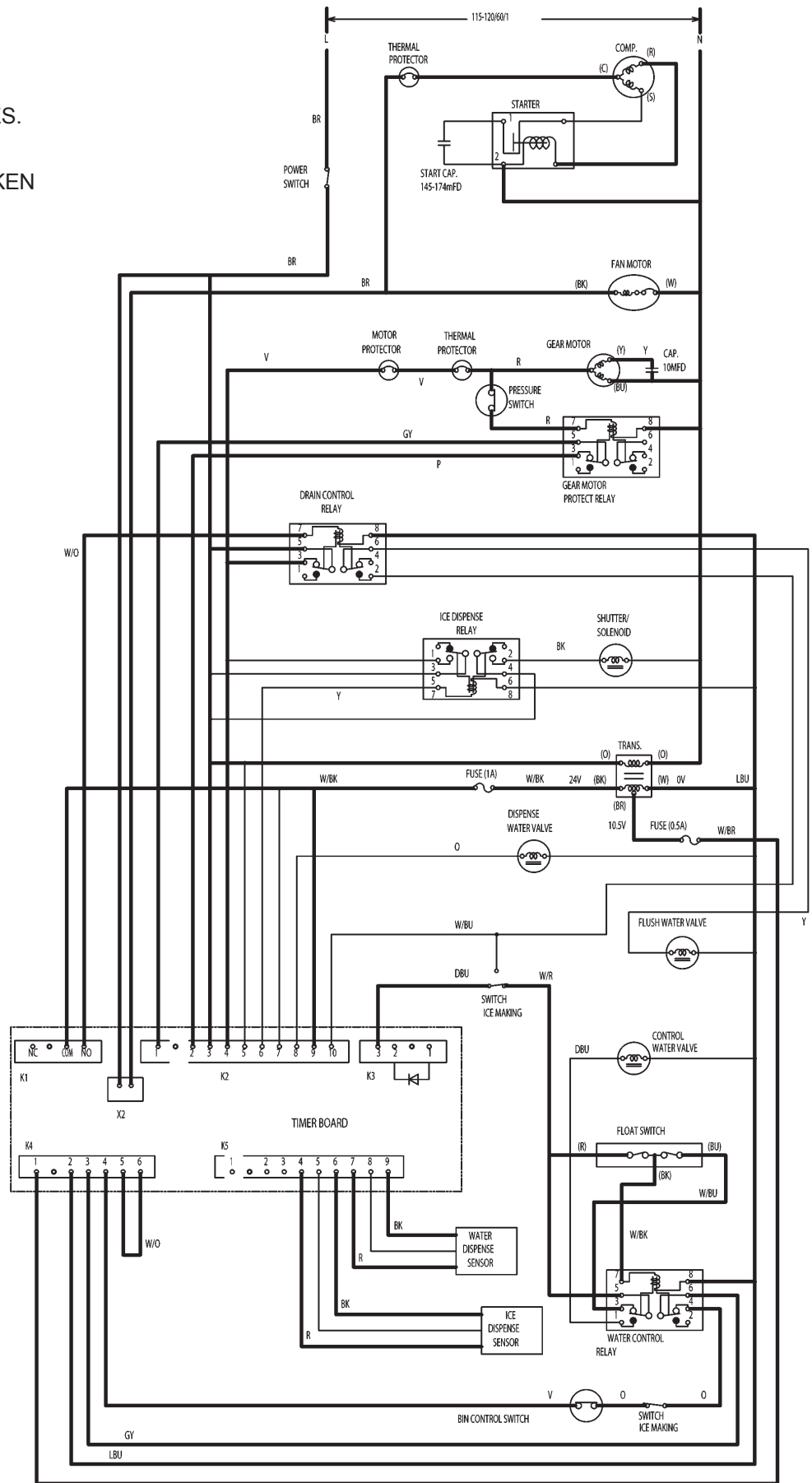

GEARMOTOR STOPS
60 SECONDS AFTER
COMPRESSOR.

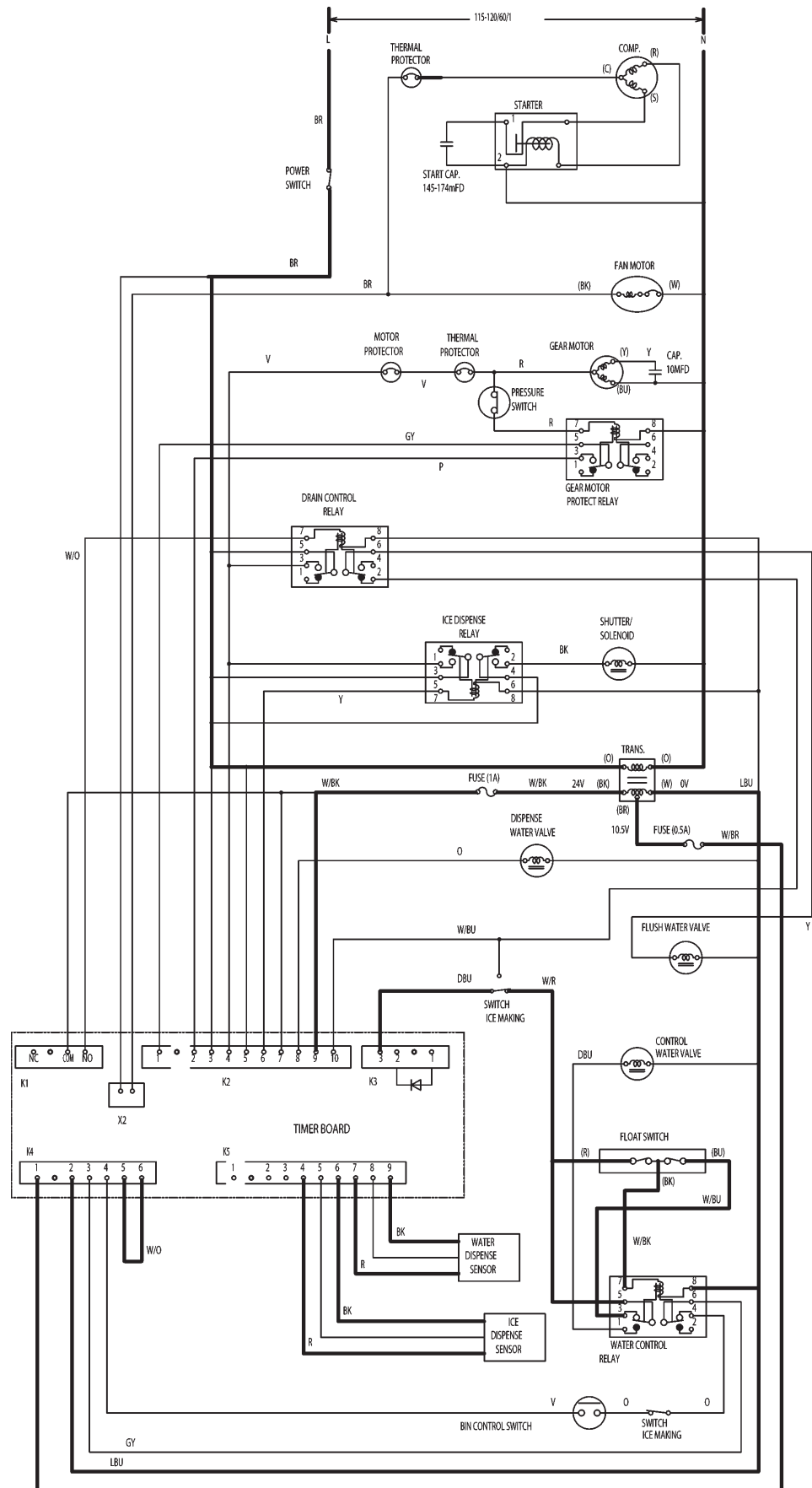

DISPENSE ICE
(BIN CONTROL STILL TRIPPED)

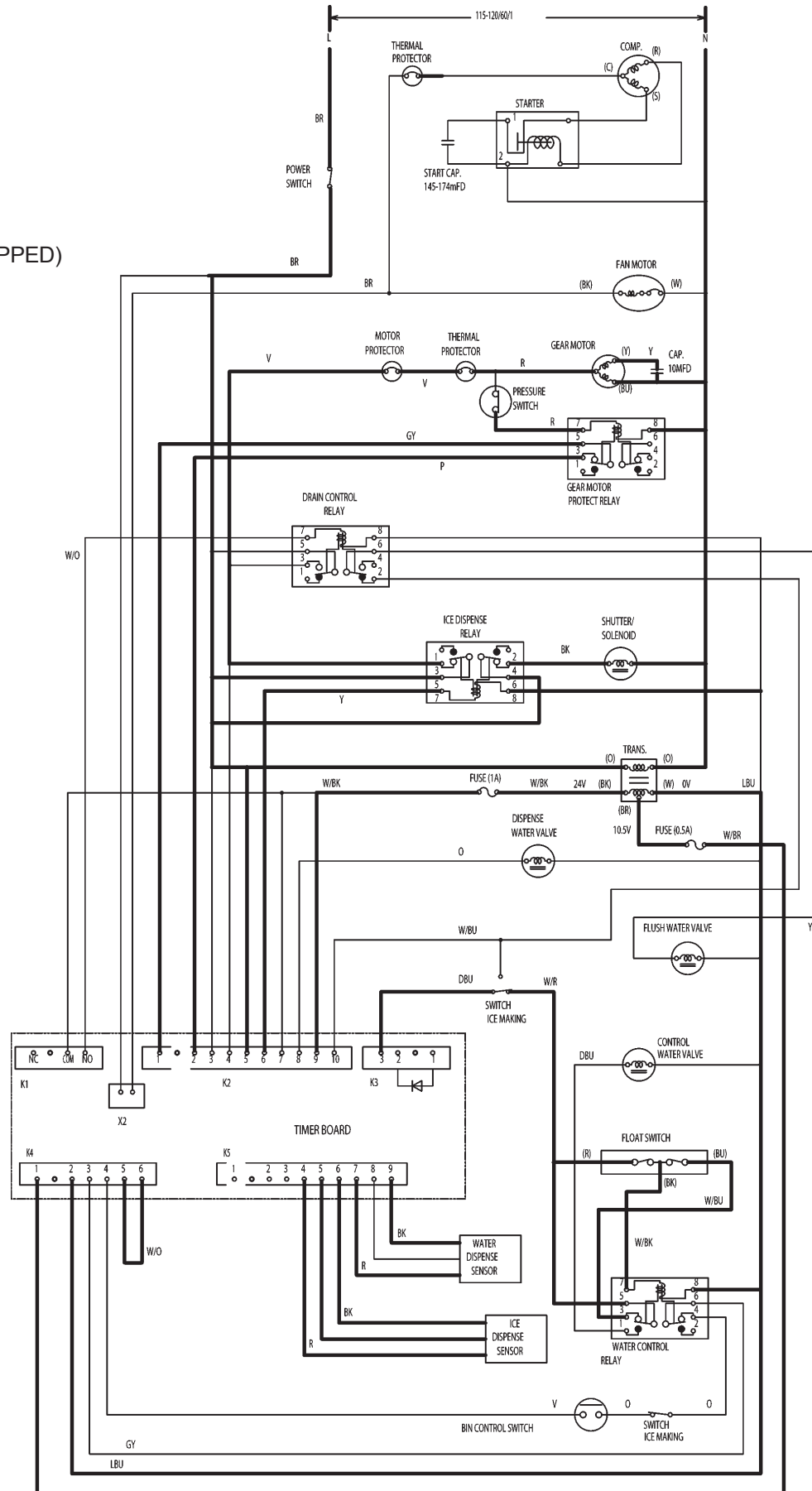

FLUSH SWITCH ACTIVATED.

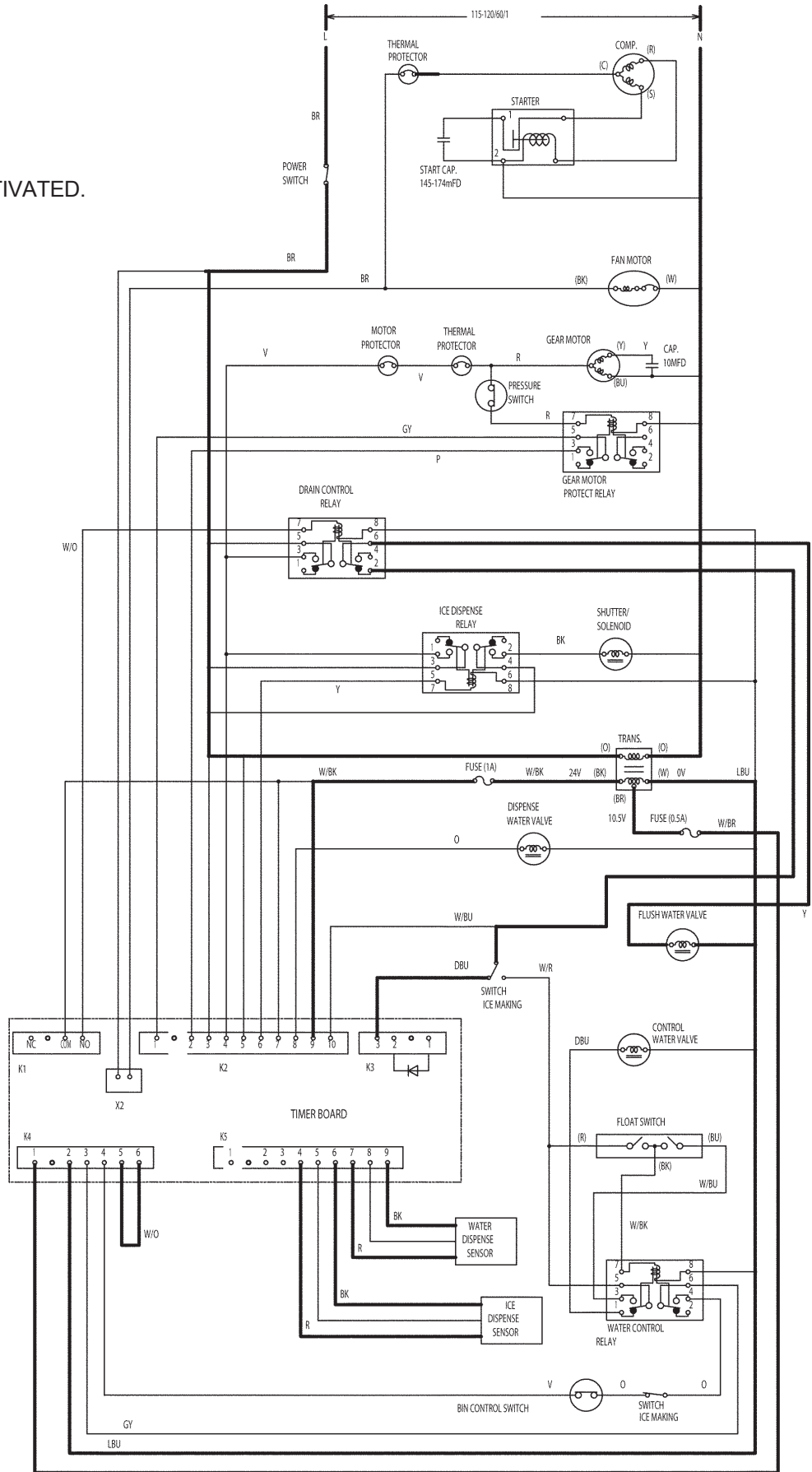

AGITATION TIMER ACTIVATES
GEAR MOTOR.

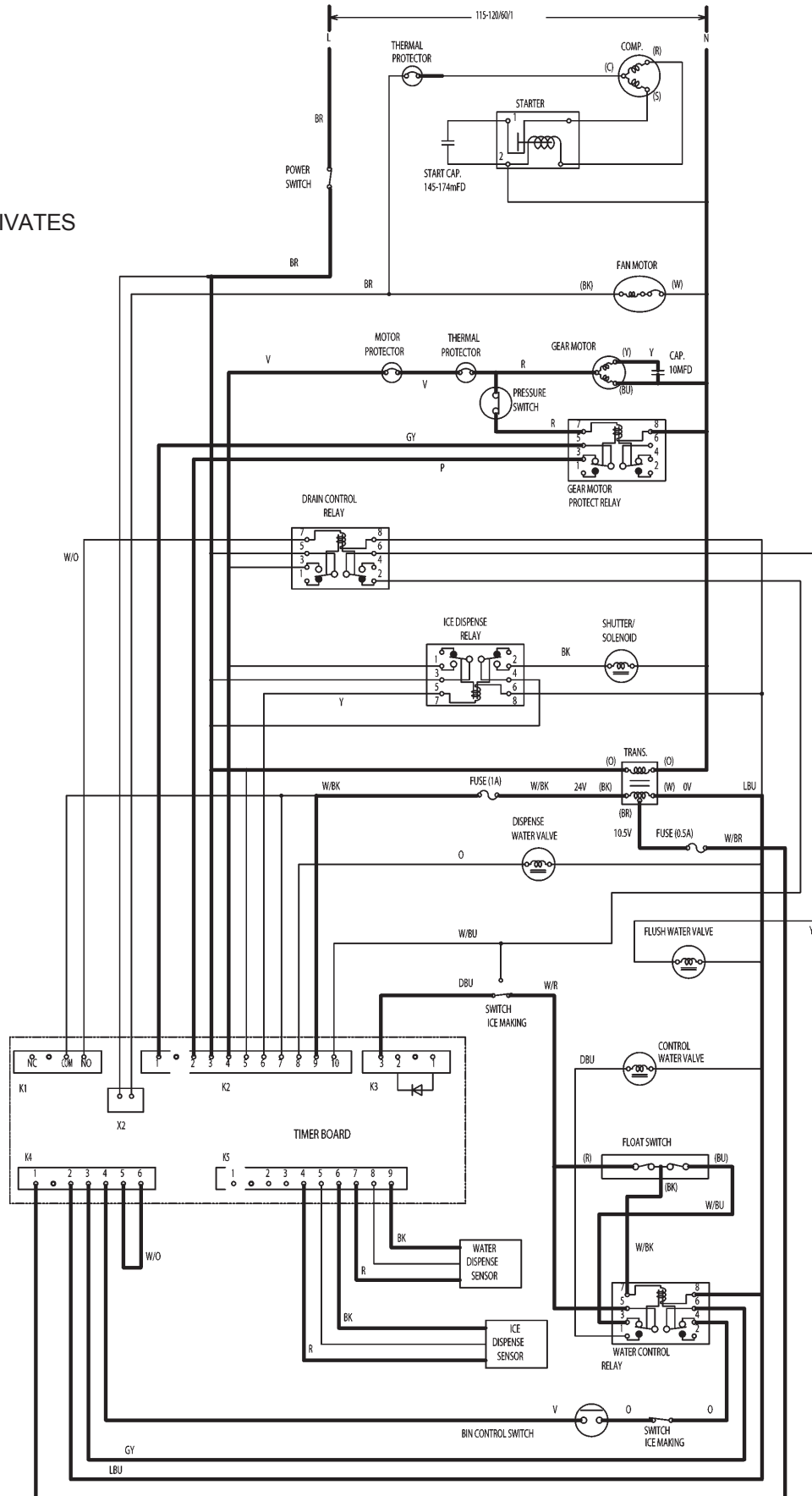

IV. Service Diagnosis

1. No Ice Production

PROBLEM	POSSIBLE CAUSE	REMEDY		
[1] The ice dispenser will not start.	a) Power Supply Cord	1. Broken or loose connection.	1. Check for continuity and replace.	
		2. Loose connection.	2. Tighten.	
		3. Bad contacts.	3. Check for continuity and replace.	
		4. Blown fuse.	4. Replace.	
	b) Power Switch (on left bottom of front panel)	1. OFF position.	1. Move to ON position.	
	c) Fuse 1A (Control Box)	1. Blown out.	1. Check for short circuit and replace.	
	[2] Water valve operates, but no ice is produced.	a) Water Supply Line	1. Shut-off valve closed.	1. Open.
2. Water supply off.			2. Check and get recommended pressure.	
b) Water Valve		1. Clogged.	1. Clean.	
c) Water Control Relay		1. Bad contacts (terminal nos. 4 and 6).	1. Check for continuity and replace.	
		2. Coil winding opened.	2. Replace.	
		3. Loose connections.	3. Tighten.	
d) Timer		1. Bad contacts.	1. Check for continuity and replace.	
		2. Coil winding opened.	2. Replace.	
		3. Loose connections.	3. Tighten.	
		4. Defective.	4. Replace.	
[3] Compressor will not start.		a) Compressor	1. Motor winding opened or grounded.	1. Replace.
		b) Timer	1. Bad contacts (X2 relay).	1. Check for continuity and replace.
	2. X2 relay coil winding opened.		2. Replace.	
	3. Loose connections.		3. Tighten.	
	c) Motor Protector	1. Bad contacts.	1. Check for continuity and replace.	
	d) Starter	1. Bad contacts.	1. Check for continuity and replace.	
e) Starting Capacitor	1. Defective.	1. Replace.		
[4] Gear motor will not start.	a) Gear Motor	1. Motor winding opened.	1. Replace.	
	b) Timer	1. Bad contacts (X1 relay).	1. Check for continuity and replace.	
	c) Protect Relay	1. Bad contacts.	1. Check for continuity and replace.	
		2. Coil winding opened.	2. Replace.	
		3. Loose connections.	3. Tighten.	
	d) Protector	1. Bad contact.	1. Check for continuity and replace.	
e) Capacitor	1. Defective.	1. Replace.		

PROBLEM	POSSIBLE CAUSE		REMEDY
[5] Fan motor will not start.	a) Fan Motor	1. Motor winding opened.	1. Replace.
		2. Bearing worn out.	2. Replace.
		3. Wiring to fan motor.	3. Check for loose connection or open, and replace.
		4. Fan blade bound.	4. Check and replace.
	b) Timer	1. Bad contacts (X2 relay).	1. Check for continuity and replace.
		2. X2 relay coil winding opened.	2. Replace.
3. Loose connections.		3. Tighten.	
[6] No water or poor flow.	a) Water Supply	1. Water failure or pressure too low.	1. Wait until water is supplied or adjust the pressure range within 10-113 PSIG.
		2. Shut-off valve closed or restricted.	2. Open.
	b) Water Valve	1. Clogged filter.	1. Clean.
		2. Coil winding opened.	2. Replace.
	c) Float Switch	1. Contacts fused.	1. Replace.
		2. Clogged.	2. Clean.
	d) Water Control Relay	1. Bad contacts (terminal nos. 1 and 5).	1. Check for continuity and replace.
		2. Contacts fused (terminal nos. 3 and 5).	2. Replace.
	e) Bin Control Switch	1. Bad contacts.	1. Check for continuity and replace.
	f) Ice Making Switch	1. "OFF" position.	1. Move to "ON" position.
		2. Bad contacts.	2. Check for continuity and replace.
	[7] Ice dispenser will not stop even if out of water.	a) Float Switch	1. Contacts fused.
2. Clogged.			2. Clean.
b) Water Control Relay		1. Contacts fused (terminal nos. 4 and 6).	1. Replace.

2. Low Ice Production

PROBLEM	POSSIBLE CAUSE		REMEDY
[1] Abnormal refrigeration circuit.	a) Condenser	1. Dirty air filter or condenser.	1. Clean.
		2. Bad ventilation.	2. Remove anything blocking vents.
	b) Thermostatic Expansion Valve	1. Low-side pressure or temperature exceeding the limit.	1. Secure bulb to low-side line or replace.
	c) Refrigerant Lines	1. Gas leaks.	1. Check for leaks with a leak detector. Reweld leak, replace drier and charge with refrigerant. The amount of refrigerant is marked on the nameplate.
		2. Overcharged.	2. Recharge.
	d) Compressor Motor Protector	1. Overload protector stops compressor intermittently.	1. Check condenser and fan motor.
e) Inside Wall of Evaporator	1. Scale on inside wall of freezing cylinder.	1. Remove auger, use Hoshizaki "Scale Away" or "LIME-A-WAY" solution to clean periodically. If water is found to exceed the following levels, install a conditioner: Hardness 50 ppm Silica 30 ppm	
[2] Condensing temperature too high.	a) Condenser	1. Dirty air filter or condenser.	1. Clean.
		2. Bad ventilation.	2. Remove anything blocking vents.
		3. Ambient temperature too high.	3. Check ventilation and location, and change as needed.
		4. Less than 6" clearance at rear, sides and top.	4. Allow proper clearance for ventilation.
	b) Fan Motor	1. Fan revolving too slowly.	1. See chart 1,[5], a)
[3] Poor water flow.	a) Water Supply	1. Water pressure too low.	1. See chart 1,[6], a)

3. Faulty Dispenser

PROBLEM	POSSIBLE CAUSE		REMEDY
[1] No ice is dispensed.	a) Storage Bin	1. Ice block or bridge.	1. Remove all ice from storage bin when not using ice dispenser for a long time.
		2. Incorrect wiring.	2. Correct wiring.
	b) Agitator	1. Deformed due to ice block or bridge.	1. Replace.
	c) Solenoid	1. Coil winding opened.	1. Replace.
	d) Ice switch or dispensing sensor.	1. Bad contacts.	1. Check for continuity and replace.
	e) Ice Dispensing Relay	1. Bad contacts.	1. Check for continuity and replace.
[2] No water is dispensed.	a) Water Valve (Dispensing)	1. Clogged filter.	1. Clean.
	b) Water Dispensing Sensor	1. Bad circuit.	1. Check for continuity and replace.
[3] Ice keeps being dispensed.	a) Shutter	1. Faulty adjustment.	1. With shutter closed, lock shutter in place by securing with two screws at the lower part of the solenoid and two screws under solenoid.
	b) Ice Switch Dispensing Switch	1. Contacts fused.	1. Replace.

[a] Optical Sensor Description

This model incorporates touch-free optical sensors to control ice and water dispensing. The sensors operate by using an emitter and two receivers encased in a waterproof sensor housing. They are designed to operate in normal lighting conditions. Direct sunlight, however, may cause the sensors to malfunction. The sensors will work with most shades (colors) of cups with a sensing distance of 45 to 65 mm. In certain water conditions, the lenses of the sensor may become scaled. Scale can block the sensor and affect the sensing operation. This scale can be removed by using a solution of Scale Away (6 fl. oz per 1 gal. of water) or other non-abrasive cleaner.

This DCM uses a different control board (part number 2A2867-01) than the push button style of DCM. This board provides an internal power source for the sensing circuit and has an additional connector (K5). This board is not interchangeable with the control board used on the push button version. When troubleshooting the sensor operation, we will be concerned with the K5 and K2 connectors on the control board. The K2 connector will supply line voltage (115VAC) to the ice dispensing motor and ice dispensing solenoid and 24VAC to the water dispense solenoid. The K5 connector provides the input and output from the sensors.

These sensors control water dispense and ice dispense in both the portion and continuous dispense operation. The ice dispense time is limited to 60 seconds regardless of whether the customer is using the "Continuous" or the "Portion Control" function. This non-adjustable, maximum timer prevents continuous dispense if someone inadvertently leaves an object in front of the dispense sensor.

If you experience problems with the ice or water dispense, use the following charts along with the wiring diagram (section III, 3) to guide you through your troubleshooting.

The following tables show the proper voltage readings for each operation.

Ice Dispensing in Continuous Mode

Lead 1		Lead 2	Dispense	Non-Dispense
K2 PIN 6 (LBU)	to	GND or NEUTRAL	120 VAC	0 VAC
K5 PIN 4 (W/O) or (RED) on sensor	to	K5 PIN 5 (Y) or (WH) on sensor	5 VDC	0 VDC
K5 PIN 4 (W/O) or (RED) on sensor	to	K5 PIN 6 (W/BR) or (BK) on sensor	5 VDC	5 VDC

Ice Dispensing in Portion Controlled Mode

Lead 1		Lead 2	Dispense	Non-Dispense
K2 PIN 6 (LBU)	to	GND or NEUTRAL	120 VAC	0 VAC
K5 PIN 1 (W/R) or (RED) on sensor	to	K5 PIN 3 (W/BK) or (BK) on sensor	5 VDC	5 VDC
K5 PIN 1 (W/R) or (RED) on sensor	to	K5 PIN 2 (W/BL) or (WH) on sensor	5 VDC	0 VDC

Water Dispensing

Lead 1		Lead 2	Dispense	Non-Dispense
K2 PIN 8 (DBU)	to	K4 PIN 2 (LBU)	24 VAC	0 VAC
K5 PIN 7 (RED)	to	K5 PIN 9 (BK)	5 VDC	5 VDC
K5 PIN 7 (RED)	to	K5 PIN 8 (WH)	5 VDC	0 VDC

Layout of Portion Control Switch Wiring (Front of Machine)

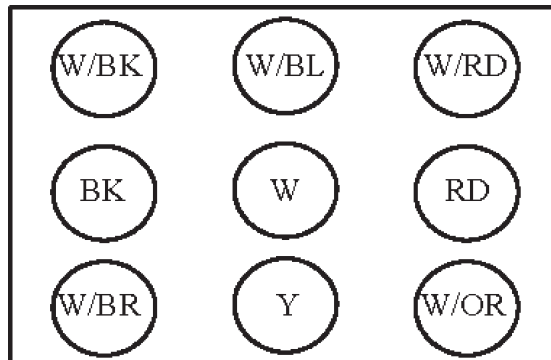

The K2 connector supplies voltage to the ice and water dispense motors and solenoids through pins 4, 6, 8. The K2 connector also has the gear motor protect circuit on pins 1, 2 the flush valve circuit on pins 9, 10 and voltage inputs on pins 3, 5, 7. The K5 connector is used exclusively for the input and output signals for the optical sensors.

4. Other

PROBLEM	POSSIBLE CAUSE		REMEDY
[1] Ice dispenser will not stop even if filled with ice.	a) Bin Control Switch	1. Contacts fused.	1. Replace.
		2. Out of position.	2. Reinstall.
	b) Water Control Relay	1. Contacts fused.	1. Replace.
[2] Reservoir overflows (water will not stop).	c) Timer	1. Defective.	1. Replace.
	a) Water Supply	1. Water pressure too high.	1. If pressure is consistently too high, install a pressure reducing valve.
	b) Water Valve	1. Cannot close.	1. Clean or replace.
	c) Float Switch	1. Bad contacts (red and black leads).	1. Check for continuity and replace.
2. Defective.		2. Replace.	
d) Water Control Relay	1. Coil winding opened.	1. Replace.	
	2. Bad contacts (terminal nos. 1 and 3)	2. Check for continuity and replace.	
[3] A lot of water drains from gear motor drain pipe.	a) Mechanical Seal (normally less than .017 fl. oz./hour)	1. Dirt stuck on seal surface.	1. Clean or replace.
		2. Worn out.	2. Replace.
[4] Abnormal noise.	a) Fan Motor	1. Bearings worn out.	1. Replace.
		2. Fan blade deformed.	2. Replace fan blade.
		3. Fan blade caught on foreign object.	3. Remove the object.
	b) Compressor	1. Bearings worn out or cylinder valve broken.	1. Replace.
		2. Mounting pad out of position.	2. Reinstall.
	c) Refrigerant Lines	1. Rubbing or touching lines or other surfaces.	1. Replace.
	d) Gear Motor (Ice Making)	1. Bearing or gear worn out / damaged.	1. Replace.
	e) Evaporator	1. Scale on inside wall of freezing cylinder.	1. See chart 2,[1], e)
	f) Solenoid (Shutter)	1. Worn out.	1. Replace.
		2. Foreign matter on plunger surface.	2. Clean.
	g) Water Valve	1. Foreign matter on plunger.	1. Clean.
h) Extruding Head	1. Bearing worn out.	1. Replace.	
i) Housing	1. Bearing worn out.	1. Replace.	

V. Removal and Replacement of Components

IMPORTANT

Ensure all components, fasteners and thumbscrews are securely in place after the equipment is serviced.

IMPORTANT

1. The Polyol Ester (POE) oils used in R-404A units can absorb moisture quickly. Therefore it is important to prevent moisture from entering the system when replacing or servicing parts.
2. Always install a new filter drier every time the sealed refrigeration system is opened.
3. Do not leave the system open for longer than 5 minutes when replacing or servicing parts.

1. Service for Refrigerant Lines

[a] Refrigerant Recovery

The icemaker unit is provided with two refrigerant access valves—one on the low-side and one on the high-side line. Using proper refrigerant practices, recover the refrigerant from these two access valves and store it in an approved container. Do not discharge the refrigerant into the atmosphere.

[b] Evacuation and Recharge [R-404A]

- 1) Attach charging hoses, a service manifold and a vacuum pump to the system. Be sure to connect charging hoses to both high and low-side access valves.

IMPORTANT

The vacuum level and vacuum pump may be the same as those for current refrigerants. However, the rubber hose and gauge manifold to be used for evacuation and refrigerant charge should be exclusively for POE oils.

- 2) Turn on the vacuum pump. Never allow the oil in the vacuum pump to flow backward.
- 3) Allow the vacuum pump to pull down to a 29.9" Hg vacuum. Evacuating period depends on pump capacity.

- 4) Close the low-side valve and high-side valve on the service manifold.
- 5) Disconnect the vacuum pump, and attach a refrigerant service cylinder to the high-side line. Remember to loosen the connection, and purge the air from the hose. See the nameplate for the required refrigerant charge. Hoshizaki recommends only virgin refrigerant or reclaimed refrigerant which meets ARI Standard No. 700-88 be used.
- 6) A liquid charge is recommended for charging an R-404A system. Invert the service cylinder. Open the high-side, service manifold valve.
- 7) Allow the system to charge with liquid until the pressures balance.
- 8) If necessary, add any remaining charge to the system through the low-side. Use a throttling valve or liquid dispensing device to add the remaining liquid charge through the low-side access port with the unit running.
- 9) Close the two refrigerant access valves, and disconnect the hoses and service manifold.
- 10) Cap the access valves to prevent a possible leak.

2. Brazing

DANGER

1. Refrigerant R-404A itself is not flammable at atmospheric pressure and temperatures up to 176° F.
2. Refrigerant R-404A itself is not explosive or poisonous. However, when exposed to high temperatures (open flames) R-404A can be decomposed to form hydrofluoric acid and carbonyl fluoride both of which are hazardous.
3. Always recover the refrigerant and store it in an approved container. Do not discharge the refrigerant into the atmosphere.
4. Do not use silver alloy or copper alloy containing arsenic.
5. Do not use R-404A as a mixture with pressurized air for leak testing. Refrigerant leaks can be detected by charging the unit with a little refrigerant, raising the pressure with nitrogen and using an electronic leak detector.

Note: All brazing connections inside the bin are clear-paint coated. Sandpaper the brazing connections before unbrazing the components. Use a good abrasive cloth to remove coating.

3. Removal and Replacement of Compressor

IMPORTANT

Always install a new drier every time the sealed refrigeration system is opened. Do not replace the drier until after all other repair or replacement has been made.

Note: When replacing a compressor with a defective winding, be sure to install the new start capacitor and start relay supplied with the replacement compressor. Due to the ability of the POE oil in the compressor to absorb moisture quickly, the compressor must not be opened more than 15 minutes for replacement or service. Do not mix lubricants of different compressors even if both are charged with R-404A, except when they use the same lubricant.

- 1) Turn off the power supply and unplug the dispenser.
- 2) Remove the panels.
- 3) Remove the terminal cover on the compressor, and disconnect the compressor wiring.
- 4) Recover the refrigerant and store it in an approved container.
- 5) Remove the discharge and suction pipes using brazing equipment.

WARNING

When repairing a refrigerant system, be careful not to let the burner flame contact the lead wires or insulation.

- 6) Remove the hold-down bolts, washers and rubber grommets.
- 7) Slide and remove the compressor. Unpack the new compressor package. Install the new compressor.
- 8) Attach the rubber grommets of the prior compressor.
- 9) Sandpaper the suction, discharge and process pipes.
- 10) Place the compressor in position, and secure it using the bolts and washers.
- 11) Remove plugs from the suction, discharge and process pipes.

- 12) Braze the process, suction and discharge lines (do not change this order), while purging with nitrogen gas flowing at the pressure 3-4 PSIG.
- 13) Install the new filter drier.
- 14) Check for leaks using nitrogen gas (140 PSIG) and soap bubbles.
- 15) Connect the terminals, and replace the terminal cover in its correct position.
- 16) Evacuate the system, and charge it with refrigerant. See the nameplate for the required refrigerant charge.
- 17) Replace the panels in their correct positions.
- 18) Plug in the dispenser and turn on the power supply.

4. Removal and Replacement of Drier

IMPORTANT

Always install a new drier every time the sealed refrigeration system is opened. Do not replace the drier until after all other repair or replacement has been made.

- 1) Turn off the power supply and unplug the icemaker.
- 2) Remove the panels.
- 3) Recover the refrigerant and store it in an approved container.
- 4) Remove the drier using brazing equipment.
- 5) Install the new drier, in the direction of the refrigerant flow. Use nitrogen gas at a pressure of 3-4 PSIG when brazing the tubings.
- 6) Check for leaks using nitrogen gas (140 PSIG) and soap bubbles.
- 7) Evacuate the system, and charge it with refrigerant. See the nameplate for the required refrigerant charge.
- 8) Replace the panels in their correct positions.
- 9) Plug in the dispenser, and turn on the power supply.

5. Removal and Replacement of Thermostatic Expansion Valve

IMPORTANT

Sometimes moisture in the refrigerant circuit exceeds the drier capacity and freezes up at the expansion valve. Always install a new drier every time the sealed refrigeration system is opened. Do not replace the drier until after all other repair or replacement has been made.

- 1) Turn off the power supply, and unplug the dispenser.
- 2) Remove the panels.
- 3) Recover the refrigerant and store it in an approved container.
- 4) Remove the insulation and the expansion valve bulb on the suction line.
- 5) Remove the expansion valve cover, and disconnect the expansion valve using brazing equipment.
- 6) Braze the new expansion valve, with nitrogen gas flowing at a pressure of 3-4 PSIG.

WARNING

1. Do not heat the wall. Place a steel barrier for protection.
2. Always protect the valve body by using a damp cloth to prevent the valve from overheating. Do not braze with the valve body exceeding 250°F.

- 7) Install the new drier.
- 8) Check for leaks using nitrogen gas (140 PSIG) and soap bubbles.
- 9) Evacuate the system, and charge it with refrigerant. See the nameplate for the required refrigerant charge.
- 10) Place the expansion valve in position.
- 11) Place the new set of expansion valve covers in position.
- 12) Attach the expansion valve bulb to the low-side line, and secure it with bulb holder and clamps.
- 13) Cover the expansion valve bulb tightly with the insulation.

- 14) Place the new expansion valve cover in position.
- 15) Replace the panels in their correct positions.
- 16) Plug in the dispenser and turn on the power supply.

6. Removal and Replacement of Pressure Switch

IMPORTANT

Always install a new drier every time the sealed refrigeration system is opened. Do not replace the drier until after all other repair or replacement has been made.

- 1) Turn off the power supply and unplug the dispenser.
- 2) Remove the panels.
- 3) Recover the refrigerant and store it in an approved container.
- 4) Remove the control box cover and disconnect the terminals.
- 5) Remove the pressure switch using brazing equipment.
- 6) Braze the new pressure switch with nitrogen gas flowing at the pressure of 3-4 PSIG.
- 7) Install the new drier.
- 8) Check for leaks using nitrogen gas (140 PSIG) and soap bubbles.
- 9) Evacuate the system, and charge it with refrigerant. See the nameplate for the required refrigerant charge.
- 10) Replace the terminals and the control box cover in their correct positions.
- 11) Replace the panels in their correct positions.
- 12) Plug in the dispenser and turn on the power supply.

7. Removal and Replacement of Control Water Valve

- 1) Unplug the icemaker.
- 2) Remove the panels.
- 3) Close the water supply line shut-off valve.
- 4) Disconnect the terminal from the control water valve.
- 5) Loosen the fitting nut on the control water valve inlets, and remove the control water valve. Do not lose the packings inside the fitting nut.
- 6) Remove the water supply hose from the control water valve.
- 7) Install the new control water valve.
- 8) Assemble the removed parts in the reverse order of the above procedure.
- 9) Open the water supply line shut-off valve.
- 10) Check for water leaks.
- 11) Replace the panels in their correct position.
- 12) Plug in the icemaker.

8. Removal and Replacement of Flush Water Valve

- 1) Turn off the power supply.
- 2) Remove the panels.
- 3) Close the water supply line shut-off valve.
- 4) Remove the clamp and disconnect the hose from the flush water valve that attaches to the evaporator.

Note: Water may still remain inside the evaporator. Be sure to drain the water into the drain pan.

- 5) Disconnect the flush water valve from the tube connected to the plastic tee leading to the drain hose.
- 6) Disconnect the terminals from the flush water valve.
- 7) Remove the flush water valve from the frame or bracket.
- 8) Connect the new flush water valve back onto the frame or bracket.
- 9) Connect the tube from the plastic tee to the new flush water valve.
- 10) Connect the hose to the flush water valve and secure it with the clamp.
- 11) Pour water into the reservoir, and check for water leaks on the flush water valve.
- 12) Open the water supply line shut-off valve.
- 13) Turn on the power supply.
- 14) Move the flush switch to the "ICE" position.
- 15) Check for water leaks.
- 16) Move the flush switch to the "FLUSH" position, and make sure water is flushing.
- 17) Move the flush switch to the "ICE" position.
- 18) Replace the panels in their correct position.

9. Removal and Replacement of Float Switch

WARNING

1. Fragile, handle very carefully.
2. If the float switch works poorly because of scale or other foreign matter, install a filter or softener in the water supply line.

- 1) Unplug the dispenser and turn off the power supply.
- 2) Close the water supply line shut-off valve.
- 3) Remove the panels.
- 4) Flush water out of the system.
- 5) Cut the float switch leads at the wire connectors.
- 6) Turn and unfasten the flanged top, and remove the float switch.
- 7) Install the new float switch.
- 8) Assemble the removed parts in the reverse order of which they were removed.
- 9) Open the water supply line shut-off valve.
- 10) Plug in the dispenser, turn on the power supply and check that the float switch works normally.

10. Removal and Replacement of Bin Control Switch Assembly

- 1) Turn off the power supply and unplug the dispenser.
- 2) Remove the top panel.
- 3) Remove the bin control switch from the storage bin cover. (Twist, then pull up.)
- 4) Cut the wire leads and remove switch.
- 5) Assemble the replacement switch, reversing the procedure used to remove the old switch.
- 6) Plug in the dispenser, turn on the power supply and check that the bin control switch works normally.

11. Removal and Replacement of Storage Bin Assembly

- 1) Move the ice making switch to the “FLUSH” position.
- 2) Press the push button to dispense ice and remove all ice from the storage bin.
- 3) Turn off the power supply and unplug the dispenser.
- 4) Remove the panels.
- 5) Remove the storage bin cover.
- 6) Remove the agitator, drip ring, drip plate and shutter assembly.
- 7) Remove the three socket head cap screws and lift off the storage bin assembly.
- 8) Install the new storage bin assembly.
- 9) Assemble the removed parts in the reverse order of which they were removed.
- 10) Plug in the dispenser and turn on the power supply.
- 11) Move the shutter to check for proper operation.
- 12) Move the ice making switch to the “ON” position.

12. Removal and Replacement of Agitator and Drip Ring

- 1) Move the ice making switch to the "OFF" position.
- 2) Press the push button to dispense ice and remove all ice from the storage bin.
- 3) Turn off the power supply, and unplug the dispenser.
- 4) Remove the top panel.
- 5) Remove the storage bin cover.
- 6) Rotate the agitator counterclockwise and lift off.
- 7) Rotate the drip ring about 30 degrees clockwise and lift off.
- 8) Install the new drip ring and agitator.
- 9) Assemble the removed parts in the reverse order of which they were removed.
- 10) Plug in the dispenser and turn on the power supply.
- 11) Move the ice making Switch to the "ON" position.

13. Removal and Replacement of Evaporator Assembly

- 1) Move the ice making switch to the “OFF” position.
- 2) Press the push button to dispense ice and remove all ice from the storage bin.
- 3) Turn off the power supply, and unplug the dispenser.
- 4) Flush all water out of the system.
- 5) Remove the panels.
- 6) Remove the storage bin assembly. (See “11. Removal and Replacement of Storage Bin Assembly.”)

Extruding Head

- 7) Lift off the extruding head.
- 8) Replace the bearing inside the extruding head, if it is worn or scratched.

Note: Replacing the bearing requires a fitting tool. If one is not available, replace the whole extruding head.

Auger

- 9) Lift up and turn the auger until it comes off. If the area in contact with the bearings is worn out or the blade is scratched, replace the auger.

Evaporator

Note: Skip the following steps 10) through 17) when the evaporator does not need replacement.

- 10) Recover the refrigerant and store it in an approved container.

WARNING

Always install a new drier every time the sealed refrigeration system is opened. Do not replace the drier until after all other repair or replacement has been made.

- 11) Remove the expansion valve cover.
- 12) Remove the insulation and the two clamps on the expansion valve bulb.

- 13) Disconnect the brazing-connections of the expansion valve and the copper tube - low side from the evaporator, using brazing equipment.
- 14) Braze the new evaporator with nitrogen gas flowing at a pressure of 3-4 PSIG.
- 15) Replace the drier.
- 16) Check for leaks using nitrogen gas (140 PSIG) and soap bubbles.
- 17) Evacuate the system and charge it with refrigerant. See the nameplate for the required refrigerant charge.
- 18) Remove the four socket head cap screws at the bottom of the evaporator.
- 19) Disconnect the hose from the evaporator.
- 20) Lift off the evaporator.

Housing and Mechanical Seal

- 21) Remove the four hexagon bolts securing the housing to the gear motor.
- 22) Remove the mechanical seal fixed on the housing.

Note: The mechanical seal consists of two parts. One moves along with the auger, and the other is fixed on the housing. If the contact surfaces of these two parts are worn or scratched, the mechanical seal may cause water leaks and should be replaced.

- 23) Replace the bearing inside the housing using a fitting tool, if the bearing is worn or scratched.

Note: Replacing the bearing requires a fitting tool. If one is not available, replace the whole housing. Be sure to install the O-ring.

Gear Motor

- 24) Cut the gear motor leads at the wire connector.
- 25) Remove the three hexagon bolts securing the gear motor on the chassis.
- 26) Remove the gear motor.
- 27) Install the new gear motor.

28) Assemble the removed parts in the reverse order of which they were removed

WARNING

Be careful not to scratch the surface of the O-ring, or it may cause water leaks. Handle the mechanical seal with care not to scratch nor to contaminate its contact surface.

29) Check for water leaks.

WARNING

After assembling the extruding head, be sure to check that the auger does not come into contact with the inner surface of the evaporator and that there is not any abnormal noise from the bearing.

30) Turn on the power supply.

31) Move the ice making switch to the "ON" position.

VI. Cleaning and Maintenance Instructions

IMPORTANT

Ensure all components, fasteners and thumbscrews are securely in place after any maintenance or cleaning is done to the equipment.

1. Preparing the Ice Dispenser for Long Storage

IMPORTANT

When shutting off the ice dispenser for an extended time, drain out all water from the water line and remove the ice from the storage bin. The storage bin should be cleaned and dried. Drain the ice dispenser to prevent damage to the water supply line at sub-freezing temperatures, using air or carbon dioxide. Shut off the ice dispenser until the proper ambient temperature is resumed.

- 1) Close the water supply line shut-off valve.
- 2) Move the ice making switch, located on the control box, to the “FLUSH” position.
- 3) Press the push button for ice dispensing, and remove all ice from the storage bin.
- 4) Wait until all water is drained out through the drain pan, and move power switch to the “OFF” position.
- 5) Unplug the ice dispenser.

IMPORTANT

Before operating the dispenser next time, open the water supply line shut-off valve.

Note: When shutting off the ice dispenser at sub-freezing temperatures, run the ice dispenser with the water supply line shut-off valve closed, and blow out the water inlet line by using air pressure.

Fig. 3

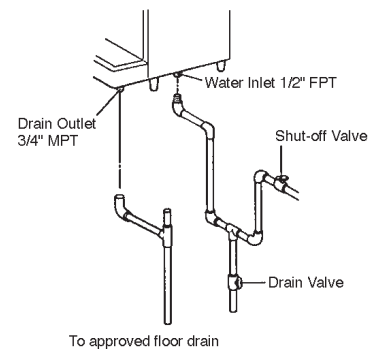

2. Cleaning Instructions

WARNING

1. HOSHIZAKI recommends cleaning this unit at least twice a year. More frequent cleaning, however, may be required in some existing water conditions.
2. To prevent injury to individuals and damage to the ice dispenser, do not use ammonia type cleaners.
3. Always wear liquid-proof gloves for safe handling of the cleaning and sanitizing solutions. This will prevent irritation in case the solution contacts the skin.

[a] Cleaning Procedure

- 1) Close the water supply line shut-off valve.
- 2) Dilute approximately 6 fl. oz. of recommended cleaner Hoshizaki "Scale Away" or "LIME-A-WAY" (manufactured by Economics Laboratory, Inc.) with 1 gal. of water.
- 3) Move the ice making switch, located on the control box, to the "FLUSH" position.
- 4) Press the "ICE" push button, and remove all ice from the storage bin.
- 5) After water has drained out through the drain pan, move the power switch to the "OFF" position.
- 6) Remove spouts (A) and (B) by removing the thumbscrew, sliding the spouts backward and then pulling them down. (See Fig. 4.)
- 7) Pull out spout (A) from spout (B).
- 8) Remove the top panel and storage bin cover. (See Fig. 5.)
- 9) Remove the agitator and drip ring. Wipe, using a clean cloth containing the cleaning solution.
- 10) Pour the cleaning solution carefully into the reservoir through the opening in the center of the storage bin up to an overflow level. (Solution that has overflowed can be seen in the drain pan.)
- 11) While waiting for 10 minutes to start icemaking process, wipe the bin liner and the drip plate using a clean cloth containing the cleaning solution.

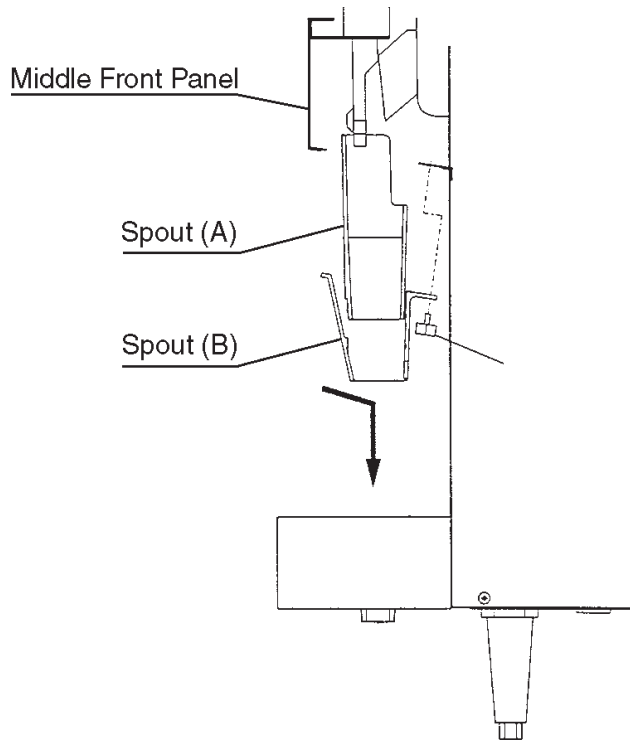

Fig. 4

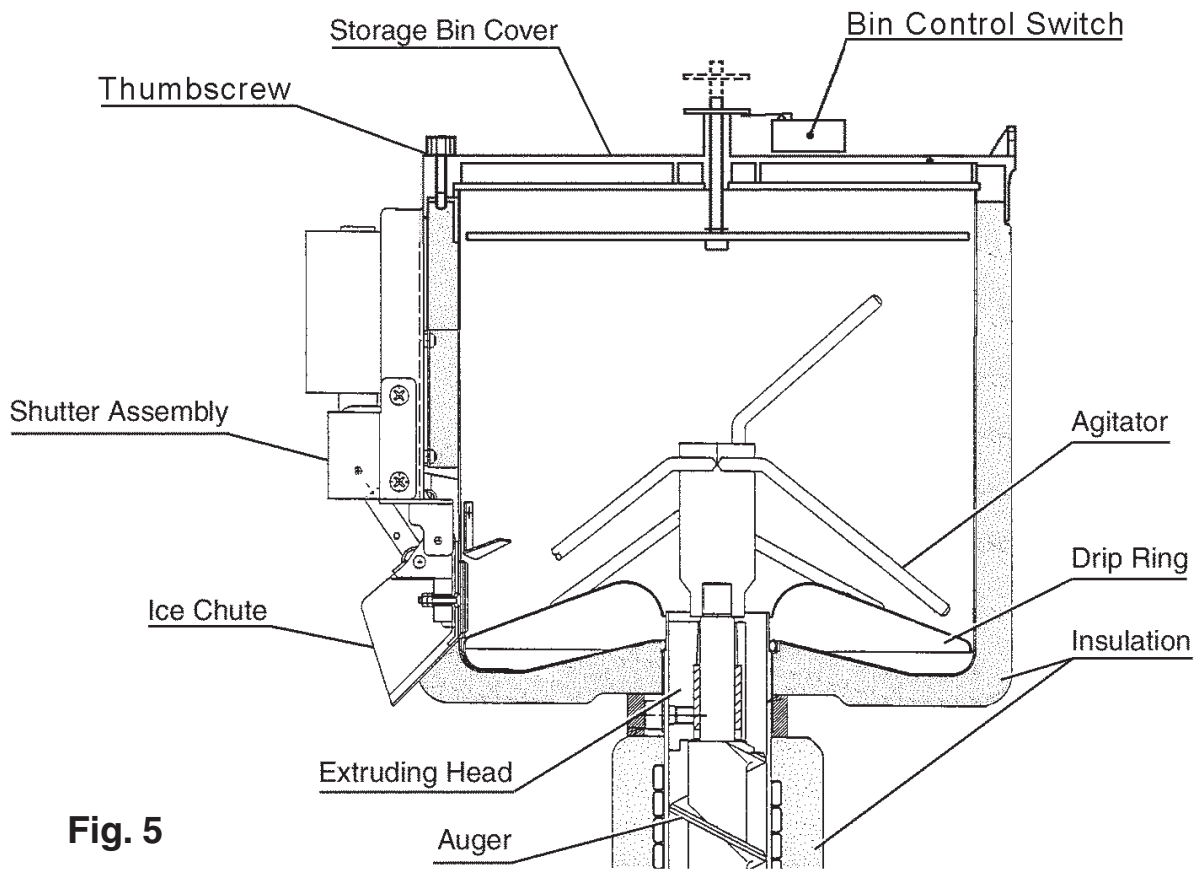

Fig. 5

- 12) Replace the drip ring and agitator.
- 13) Move the ice making switch and then the power switch to the “ON” position. Place the storage bin cover in position, and start the automatic icemaking process. Run the ice dispenser until it stops automatically.
- 14) Move the ice making switch to the “FLUSH” position, and wait for flush process to begin (60 seconds).
- 15) Pour clean, warm water carefully onto the bin liner, agitator, drip ring and into the reservoir through the opening in the center of the storage bin to melt the ice and rinse out the cleaning solution.
- 16) Move the power switch to the “OFF” position.
- 17) Wipe the storage bin cover and spouts (A) and (B) using a clean cloth containing the cleaning solution.
- 18) Rinse the wiped parts with water. Be careful not to wet the bin control switch on the storage bin cover.

CAUTION

Do not use ice produced with cleaning and sanitizing solutions. Be sure none remains in the storage bin.

[b] Sanitizing Procedure

- 1) Dilute approximately 1.5 fl. oz. of a 5.25% sodium hypochlorite solution (chlorine bleach) with 3 gal. of water.
- 2) Pour the sanitizing solution carefully into the reservoir through the opening in the center of the storage bin up to an overflow level.
- 3) Wait for 10 minutes to start the icemaking process. Move the ice making switch to the "ON" position, and start the automatic icemaking process. Run the ice dispenser until it stops automatically.
- 4) Move the ice making switch to the "FLUSH" position.
- 5) Wipe the bin liner and the drip plate using a clean cloth containing the sanitizing solution.
- 6) Pour clean, warm water carefully onto the bin liner and into the reservoir through the opening in the center of the storage bin to melt the ice and rinse out the sanitizing solution. Be careful not to wet the bin control switch on the storage bin cover.
- 7) Remove the bin control switch from the storage bin cover, and immerse the storage bin cover, agitator, drip ring and spouts (A) and (B) in the sanitizing solution.
- 8) Rinse the parts sanitized above, using water.
- 9) Place the parts rinsed above back in position. Reattach the bin control switch to the storage bin cover.
- 10) After water has drained out through the drain pan, open the water supply line shut-off valve and move the ice making switch to the "ON" position. Run the ice dispenser for 30 minutes.
- 11) Move the ice making switch to the "FLUSH" position, and let all water drain out through the drain pan.
- 12) Press the "ICE" push button, and remove all ice from the storage bin.
- 13) Place the top panel in position.
- 14) Move the ice making switch to the "ON" position, and start the automatic and continuous icemaking process.

2. Maintenance Instructions

IMPORTANT

This ice dispenser must be maintained individually, referring to the instruction manual and labels provided with the ice dispenser.

1) Stainless Steel Exterior

To prevent corrosion, wipe the exterior occasionally with a clean and soft cloth. Use a damp cloth containing a neutral cleaner to wipe off oil or dirt build up.

2) Air Filter - See Fig. 6

A plastic mesh air filter removes dirt or dust from the air, and keeps the condenser from getting clogged. As the filter gets clogged, the ice dispenser's performance will be reduced. Check the filter at least twice a month. When clogged, use warm water and a neutral cleaner to wash the filter.

3) Condenser

Check the condenser once a year, and clean if required by using a brush or vacuum cleaner. More frequent cleaning may be required depending on the location of the ice dispenser.

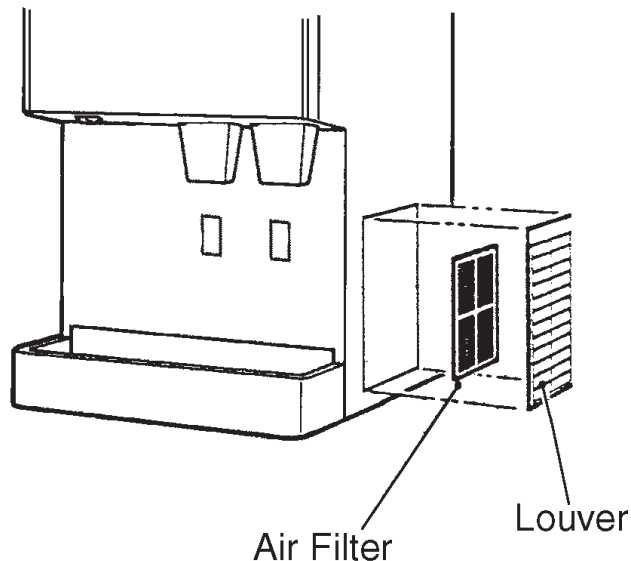

Fig. 6