

# Hoshizaki America, Inc.

## Modular Flaker Serenity Series

Model  
FS-1001MLH-C



“A Superior Degree  
of Reliability”

[www.hoshizaki.com](http://www.hoshizaki.com)

## PARTS LIST



Number: 71233  
Issued: 5-23-2005  
Revised: 7-18-2011

## CONTENTS

Auxiliary Codes.....	3
Note About Ordering Parts .....	3
A. Ice Flaker Assembly .....	4
B. Ice Making Unit.....	7
C. Refrigeration Circuit.....	9
D. Water Circuit .....	11
E. Control Box Assembly.....	13
F. Chute Assembly .....	15
G. Label Location.....	17
H. Accessories & Packaging .....	19

## Auxiliary Codes

### FS-1001MLH-C

P-0	July 2004
Q-0	July 2005
S-0	February 2007
T-0	April 2008
T-1	October 2008
U-0	January 2009
U-1	December 2009
V-0	January 2010
V-1	February 2010
V-2	October 2010
V-3	November 2010
A-0	January 2011

### Auxiliary Code Breakdown

The auxiliary code is the first two characters in the serial number. The first character indicates the year. Years progress or regress in alphabetical order. The series runs from "A" through "V" and the letters "I" and "O" are skipped. The second character indicates significant part changes within a year. Base is "0" and this number advances for each change. In cases where there is a letter in parentheses, this designates the month. This is the last character in the serial number. The series runs from "(A)" through "(M)" and the letter "(I)" is skipped. This designation is only included when identifying a parts change within an auxiliary code.

### Note About Ordering Parts

Most assemblies cannot be ordered as complete units; parts in the assemblies generally must be ordered separately.

**A. Ice Flaker Assembly**  
**FS-1001MLH-C**  
 P-0 to A-0

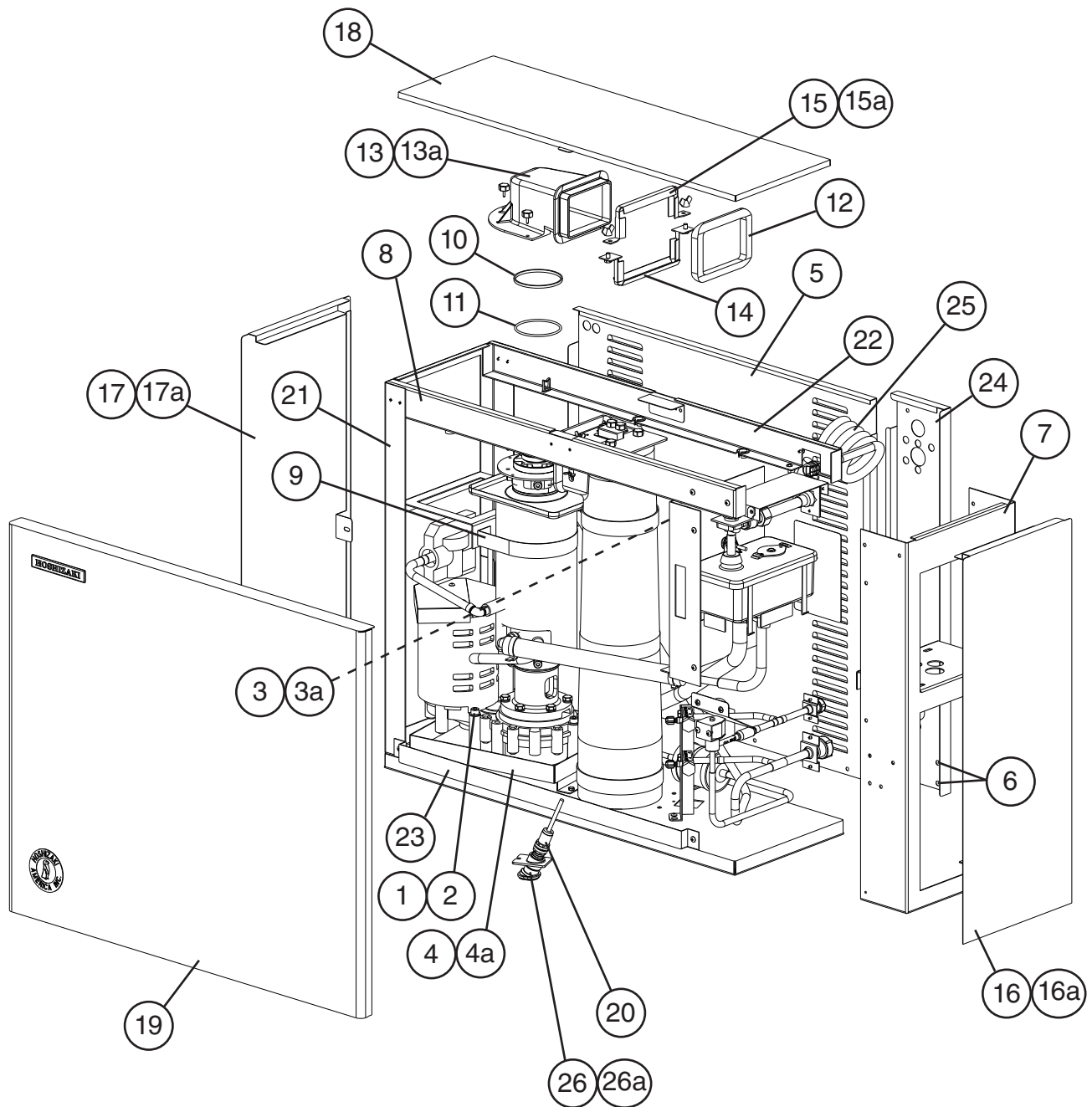

Title: <b>A. Ice Flaker Assembly</b> Model: <b>FS-1001MLH-C</b>												
Index No.	Description	Material or Model Number	Part Number	Required Number								
				P-0 (G) to P-0 (L)	P-0 (M) to Q-0 (J)	Q-0 (K) to U-0 (D)	U-0 (E)	U-1 V-0	V-1 (B) to V-1 (H)	V-1 (J) to A-0		
<b>Ice Flaker Assembly Order Assembly Parts Individually</b>			1A0946A01	1	1	1	1	-				
			1A0946A02					1	-			
			1A1952A01						1	1		
1	Socket Head Cap Screw	8x90, SS	7S12-0890	3	3	3	3	3	3	3		
2	Split Lock Washer	M8, SS	7L22-0800	3	3	3	3	3	3	3		
3	Taper Collar		4H0171-01	2	2	2	2	2	2	2		
3a	Flat Head Screw	4x8	7C21-0408	2	2	2	2	2	2	2		
4	Drain Pan Assembly		3A3231G01	1	1	1	1	1	1	1		
4a	Hex Head Bolt	5x10, SS (LF)	7B02-0510	2	2	2	2	2	2	2		
5	Rear Panel		2A3146-01	1	1	1	1	1	1	1		
6	Hex Head Bolt w/ Washer (Dispenser Unit/Storage Bin Attachment Bolts)	5x12, SS (LF)	7B0130512	4	4	4	4	4	4	4		
7	Side Frame (R)		2A3138-01	1	-							
			2A3395-01		1	1	1	1	-			
			2A5484-01						1	1		
8	Front Frame Assembly		3A3210G01	1	1	-						
			3A3816G01			1	-					
			3A5419-01				1	1	-			
			3A5814G01						1	1		
9	Evaporator Strap		4A3431-01	1	1	1	1	1	1	1		
10	Ring		432661-02	1	1	1	1	1	1	1		
11	"O" Ring		7616-G070	1	1	1	-					
			4A4755-03				1	1	1	1		
12	Spout Packing		321037-01	1	1	1	1	1	1	1		
13	Spout		104797-01	1	1	1	1	1	1	1		
13a	Thumbscrew		415949G08	3	3	3	3	3	3	3		
14	Lower Spout Strap		321038G02	1	1	1	1	1	1	1		
15	Upper Spout Strap		328703-02	1	1	1	1	1	1	1		
15a	Wing Nut	6, SS	7E12-0600	2	2	2	2	2	2	2		
16	Side Panel Assembly (R)		3A3328G01	1	1	1	1	1	1	1		
16a	Thumbscrew		415949G10	1	1	1	1	1	1	1		
17	Side Panel Assembly (L)		3A3329G01	1	1	1	1	1	1	1		
17a	Thumbscrew		415949G10	1	1	1	1	1	1	1		
18	Top Panel		2A3140-01	1	1	1	1	1	1	1		
19	Front Panel		2A3145-01	1	1	1	1	1	1	1		
20	Infrared Sensor-Bin Control		4A3773-01	1	1	1	1	-				
			4A4469-01					1	1	1		
21	Side Frame (L)		2A3139-01	1	1	1	1	1	-			
			2A5483-01						1	1		

Title: **A. Ice Flaker Assembly** Model: **FS-1001MLH-C**

Index No.	Description	Material or Model Number	Part Number	Required Number								
				P-0 (G) to P-0 (L)	P-0 (M) to Q-0 (J)	Q-0 (K) to U-0 (D)	U-0 (E)	U-1 (V-0)	V-1 (B) to V-1 (H)	V-1 (J) to A-0		
22	Rear Frame Assembly		3A3211G01	1	1	-						
			3A3815G01			1	-					
			3A5418-01				1	1	-			
			3A5813G01						1	1		
23	Front Bracket		3A3240-01	1	1	1	1	1	1	1		
24	Rear Panel Cover		2A3396-01	1	1	1	1	1	1	1		
25	Power Cord		4A1773-01	1	1	1	1	1	1	1		
26	Infrared Sensor Housing		3A3478-01	1	1	1	1	1	1	1		
26a	Thumbscrew		415949G10	1	1	1	1	1	1	1		

**B. Ice Making Unit**  
**FS-1001MLH-C**  
P-0 to A-0

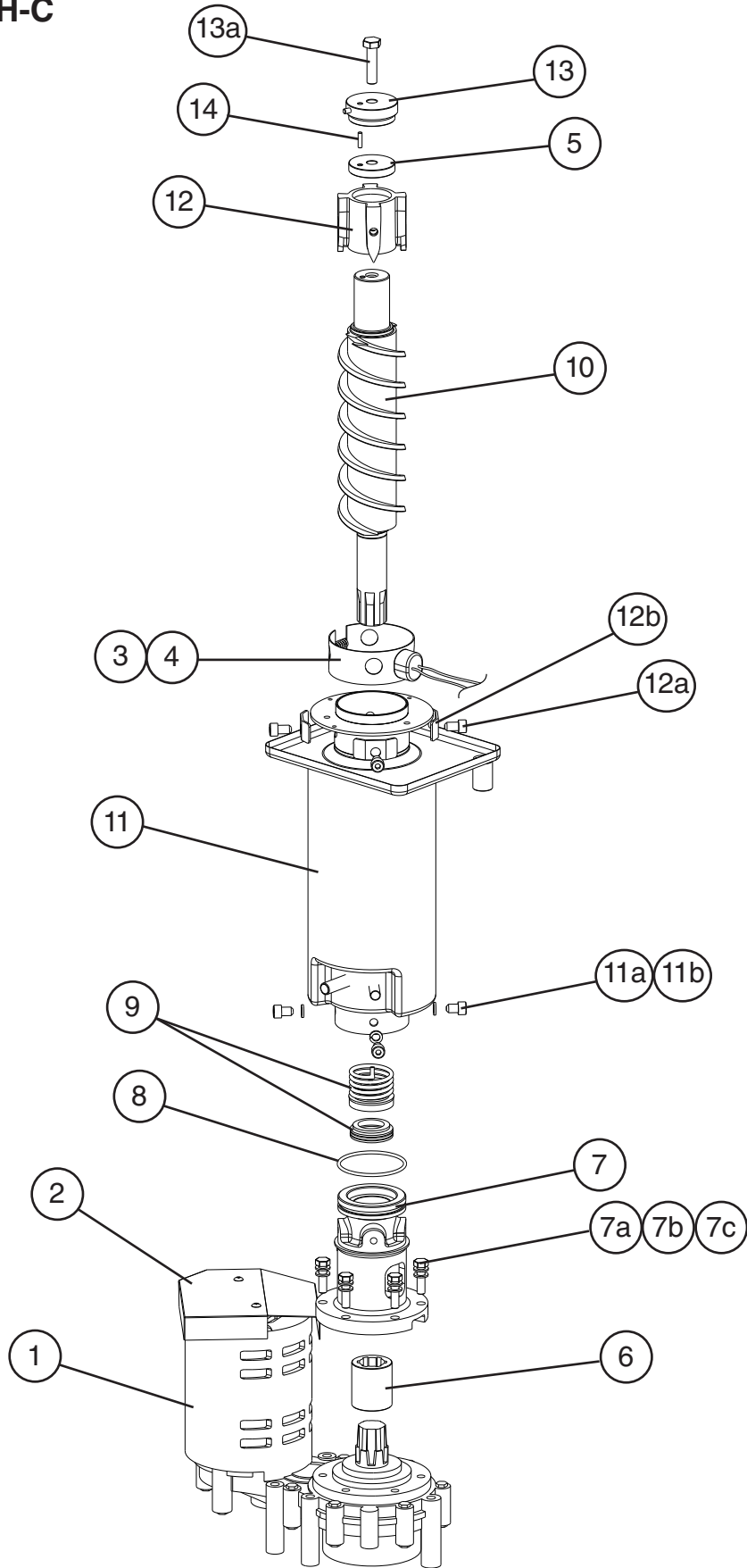

Title: <b>B. Ice Making Unit</b> Model: <b>FS-1001MLH-C</b>												
Index No.	Description	Material or Model Number	Part Number	Required Number								
				P-0 to T-0	T-1 to U-0 (D)	U-0 (E) to V-1	V-2	V-3 A-0				
<b>Ice Making Unit Order Assembly Parts Individually</b>			3A3157A01	1	1	1	1	1				
1	Gear Motor (for mounting hardware, see section "A" items 1 and 2)		4A2007-01	1	1	1	1	1				
2	Gear Motor Barrier		4A3441-01	1	1	1	1	1				
3	Heater		4A2292-01	1	1	1	1	1				
4	Spring		4A2292F01	1	1	1	1	1				
5	Washer		4A3418-01	1	1	1	1	1				
6	Spline Coupling		414137-01	1	1	1	1	1				
7	Housing		2A1977G01	1	1	1	1	1				
7a	Hex Head Bolt	8x30, SS	7B02-0830	6	6	6	6	6				
7b	Flat Washer	M8, SS	7W22-0800	6	6	6	6	6				
7c	Split Lock Washer	M8, SS	7L22-0800	6	6	6	6	6				
8	"O" Ring		7616-G065	1	1	-						
			4A4755-02			1	1	1				
9	Mechanical Seal		432492-01	1	1	1	1	1				
10	Auger		2A2151G03	1	-							
			1A1541G02		1	1	-					
			1A2037G02				1	-				
			120863G02					1				
11	Evaporator		2A1733G01	1	1	1	1	1				
11a	Socket Head Cap Screw	8x12, SS	7S12-0812	4	4	4	4	4				
11b	Split Lock Washer	M8, SS	7L22-0800	4	4	4	4	4				
12	Extruding Head		216530G04	1	1	1	1	1				
12a	Seal Bolt	M8, SS	P01768-01	4	4	4	4	4				
12b	Washer		427184-01	4	4	4	4	4				
13	Cutter		4A3443G02	1	1	1	1	1				
13a	Hex Head Bolt	10x40, SS	7B02-1040	1	1	1	1	1				
14	Dowel Pin		713S-0416	1	1	1	1	1				



**C. Refrigeration Circuit**  
**FS-1001MLH-C**  
P-0 to A-0

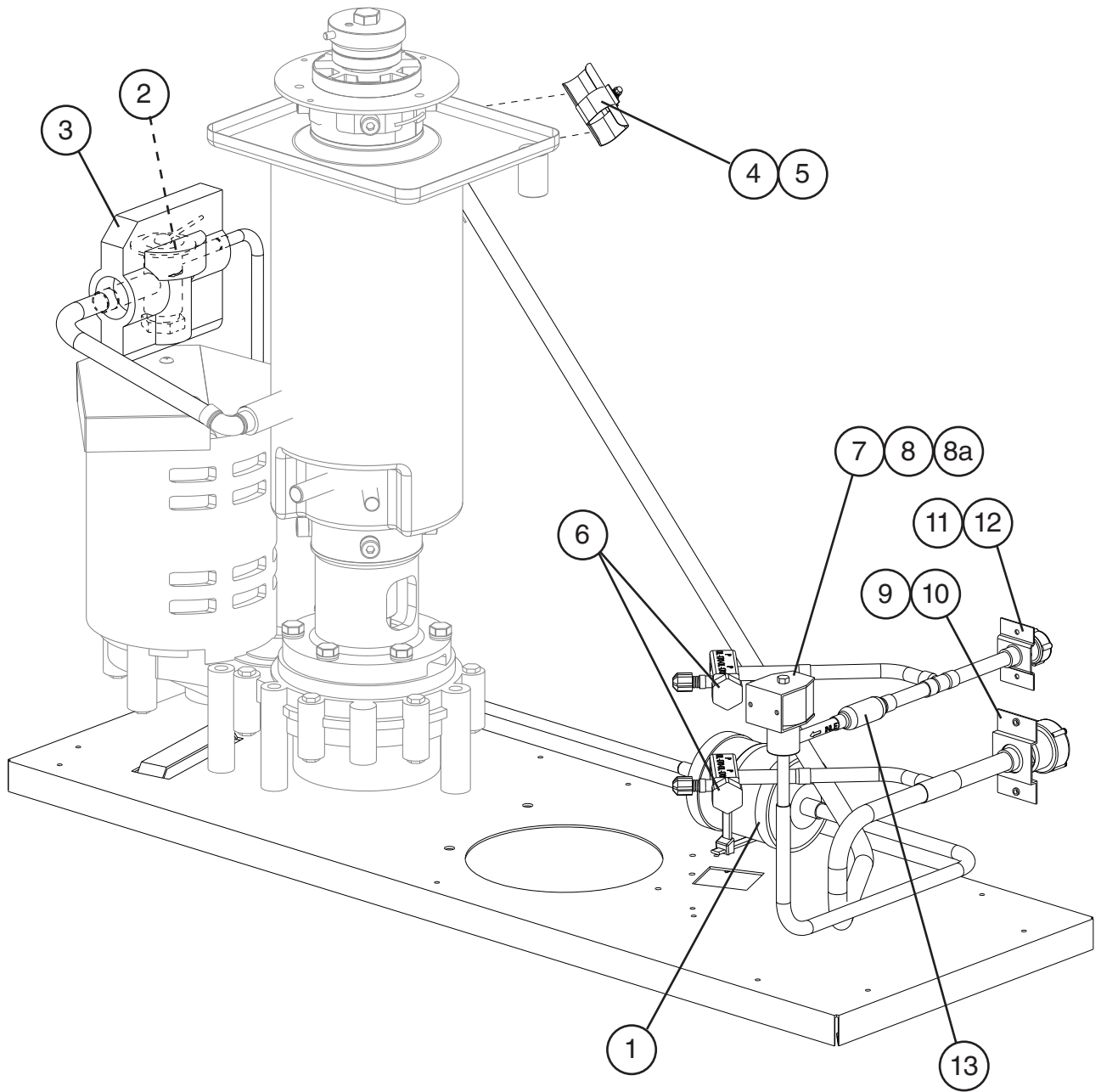

Title: **C. Refrigeration Circuit** Model: **FS-1001MLH-C**

Index No.	Description	Material or Model Number	Part Number	Required Number									
				P-0 to Q-0 (J)	Q-0 (K) to A-0								
<b>Refrigeration Circuit Order Assembly Parts Individually</b>			1A0947A01	1	1								
1	Drier		4A1338-01	1	1								
2	Expansion Valve		4A3493-01	1	1								
3	Expansion Valve Cover		4A1168-01	1	1								
4	Expansion Valve Bulb Holder		3A0112-01	1	1								
5	Clamp		443461-01	1	1								
6	Service Valve		4A3420-01	2	2								
7	Line Valve Body		440352-01	1	-								
			4A3276-01		1								
8	Valve Coil		440353-01	1	-								
			4A3277-01		1								
8a	Bolt		440353F01	1	-								
			4A3277F01		1								
9	Coupling		434072-01	1	1								
10	Tube Holder-L		438245-01	1	1								
11	Coupling		426554-01	1	1								
12	Tube Holder-S		438246-01	1	1								
13	Strainer		4A1385-01	1	1								

**D. Water Circuit**  
**FS-1001MLH-C**  
P-0 to A-0

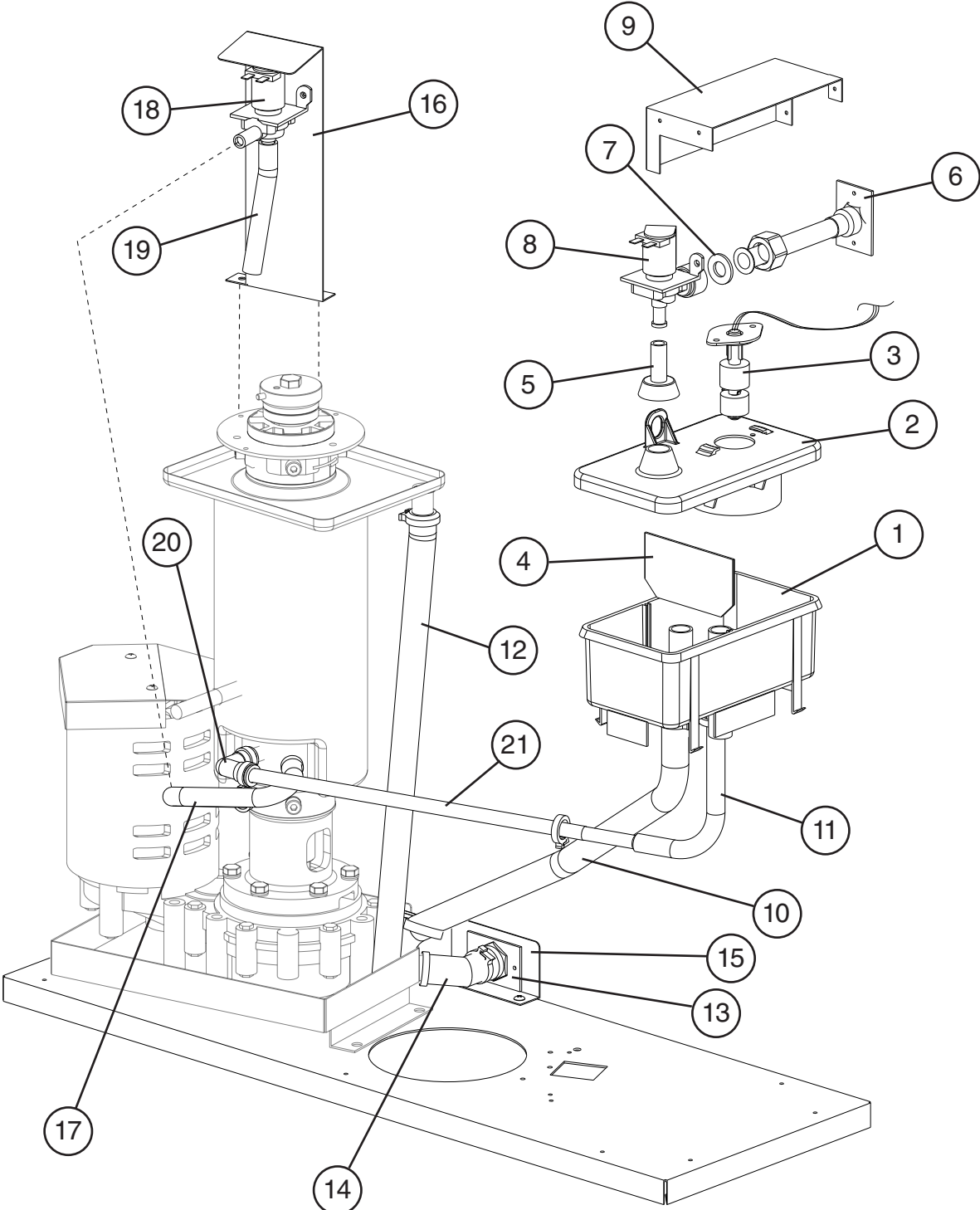

Title: <b>D. Water Circuit</b> Model: <b>FS-1001MLH-C</b>											
Index No.	Description	Material or Model Number	Part Number	Required Number							
				P-0 to Q-0 (J)	Q-0 (K) to S-0 (F)	S-0 (G) to A-0					
<b>Water Circuit Order Assembly Parts Individually</b>			2A3137A01	1	1	-					
			2A3137A02			1					
1	Reservoir		2A0753-01	1	1	1					
2	Reservoir Cover		214810-01	1	1	1					
3	Float Switch		435490-01	1	1	1					
4	Reservoir Separator		4A1255-01	1	1	1					
5	Reservoir Inlet		4A0869-01	1	1	1					
6	Water Supply Pipe		3A3161G01	1	1	1					
7	Washer		4A0867-01	1	1	1					
8	Inlet Water Valve		4A0865-01	1	1	1					
9	Inlet Water Valve Bracket		4A3728-01	1	1	1					
10	Silicone Hose	L=575mm	7730-1822	1	1	1					
11	Reservoir Hose		4A1165-06	1	1	1					
12	Vinyl Hose	L=450mm	7725-1923	1	1	1					
13	Fitting		4A0776G01	1	1	1					
14	Vinyl Hose	L=45mm	7716-2025	1	1	1					
15	Drain Fitting Bracket		4A3447-01	1	1	1					
16	Drain Valve Bracket		4A3667-01	1	1	1					
17	Vinyl Hose	L=320mm	7716-1216	1	-						
	Silicone Hose		7730I3896		1	1					
18	Drain Valve		4A2772-01	1	1	1					
19	Vinyl Hose	L=65mm	7716-0913	1	-						
		L=115mm	7716-1216		1	1					
20	Elbow		4A3671-01	1	1	-					
			4A4316-01			1					
21	Reservoir Tube	L=320mm	4A3672-01	1	1	-					
	Polyethylene Tube		4A4317L01			1					
<b>Clamps</b>											
	Hose Clamp	17.1 - 20.6mm	4A2017-05	1	1	1					
	Hose Clamp	22.2 - 25.4mm	4A2017-09	5	5	5					
	Hose Clamp	13.5 - 15.1mm	4A2017-08	2	2	2					

**E. Control Box Assembly**  
**FS-1001MLH-C**  
 P-0 to A-0

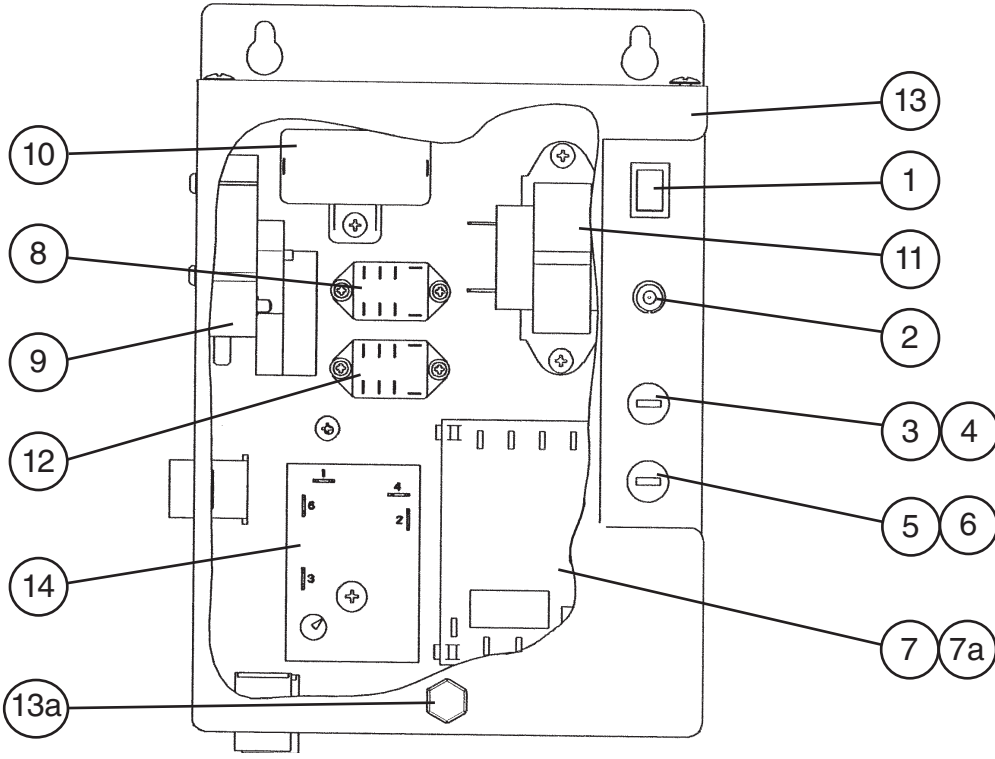

P-0 to U-0

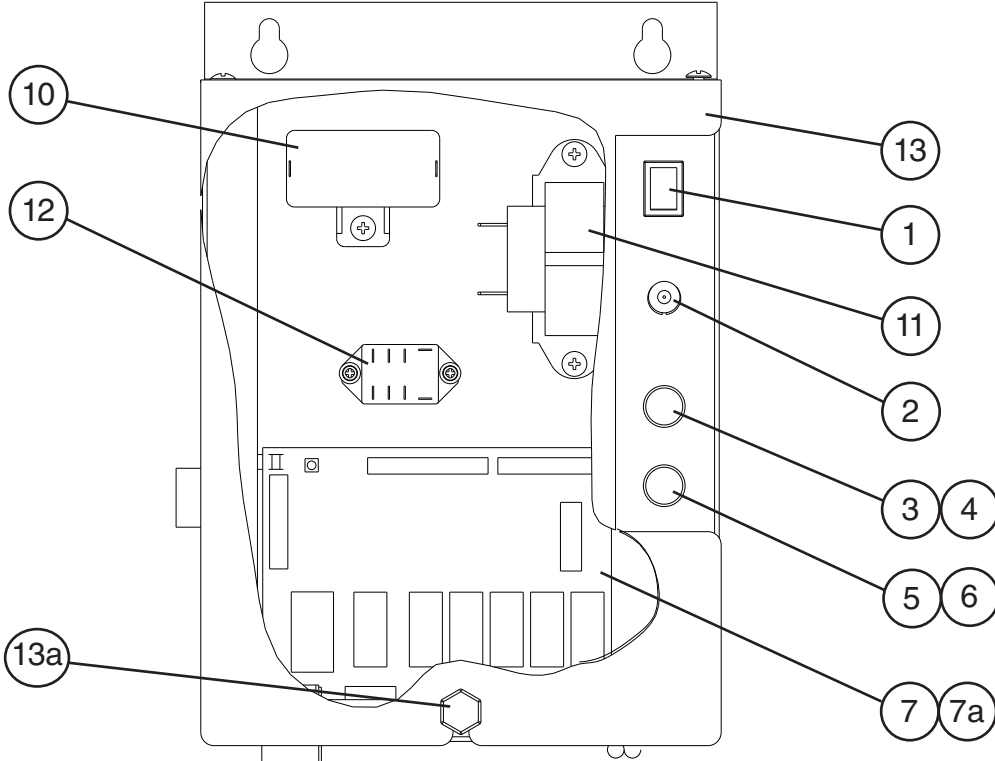

U-1 to A-0

Title: <b>E. Control Box Assembly</b> Model: <b>FS-1001MLH-C</b>											
Index No.	Description	Material or Model Number	Part Number	P-0	Q-0	U-1	A-0				
				to Q-0 (J)	(K) to U-0	to V-3					
<b>Control Box Assembly Order Assembly Parts Individually (for mounting hardware, see section "A" items 4 and 4a)</b>			3A3501A01	1	1	-					
			3A5547A01			1	1				
1	Rocker Switch (Flush)		4A0558-01	1	1	1	1				
2	Toggle Switch (Power)		4A2332-01	1	1	1	1				
3	Fuse Holder		4A0892-01	1	1	1	-				
			4A3449-01				1				
4	Control (Timer) Board Fuse	1A, 250VAC	4A0893-01	1	1	1	1				
5	Fuse Holder		4A0892-02	1	1	1	-				
			4A3449-02				1				
6	Gear Motor Fuse	3A, 250VAC	4A0893-06	1	1	1	1				
7	Control (Timer) Board		437305-01	1	1	-					
			2A4296-01			1	1				
7a	Board Support		4A0336-03	4	4	4	4				
8	Water Control Relay		406132-03	1	1	-					
9	Cam Timer		4A2157-01	1	1	-					
10	Gear Motor Capacitor	24MFD, 250VAC	4A2273-01	1	1	1	1				
11	Control Transformer		4A0557-01	1	1	1	1				
12	Gear Motor Protect Relay		406132-07	1	1	-					
			418271-03			1	1				
13	Control Box Cover		4A3675-01	1	1	1	1				
13a	Thumbscrew		415949G10	1	1	1	1				
14	Time Delay Relay		4A3761-01	1	-						
			4A3940-01		1	-					

**F. Chute Assembly**  
**FS-1001MLH-C**  
P-0 to A-0

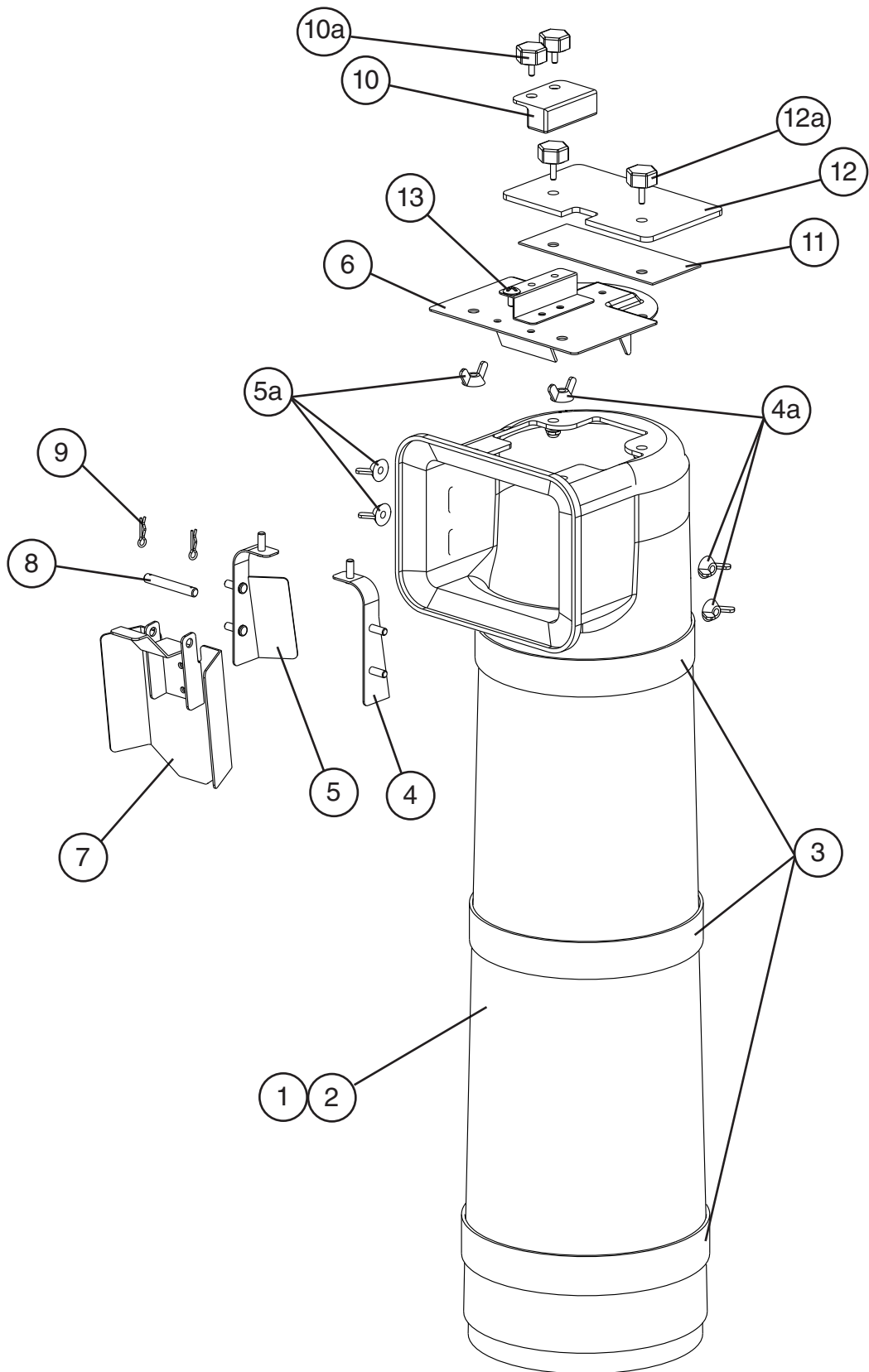

Title: **F. Chute Assembly** Model: **FS-1001MLH-C**

Index No.	Description	Material or Model Number	Part Number	Required Number									
				P-0 to T-0 (E)	T-0 to A-0 (F)								
<b>Chute Assembly Order Assembly Parts Individually</b>		HS-2024	2A1705A04	1	1								
1	Chute		2A1919-01	1	1								
2	Chute Insulation		2A1920-01	1	1								
3	Tie		436531G01	3	3								
4	Chute Baffle A		3A0400G01	1	1								
4a	Wing Nut	4, SS	7E12-0400	3	3								
5	Chute Baffle B		3A0399G01	1	1								
5a	Wing Nut	4, SS	7E12-0400	3	3								
6	Bin Control Bracket		3A1744G01	1	1								
7	Actuator		436848G01	1	1								
8	Shaft		436851-01	1	1								
9	Snap Pin		715S-0005	2	2								
10	Mechanical Bin Control Proximity Switch		4A2033-01	1	1								
10a	Thumbscrew		415949G08	2	2								
11	Packing		441217-01	1	-								
12	Plate		4A2039-01	1	1								
12a	Thumbscrew		415949G10	2	2								
13	Ground Screw	4x8, SS	7C32-0408	1	1								



**G. Label Location**  
**FS-1001MLH-C**  
 P-0 to A-0

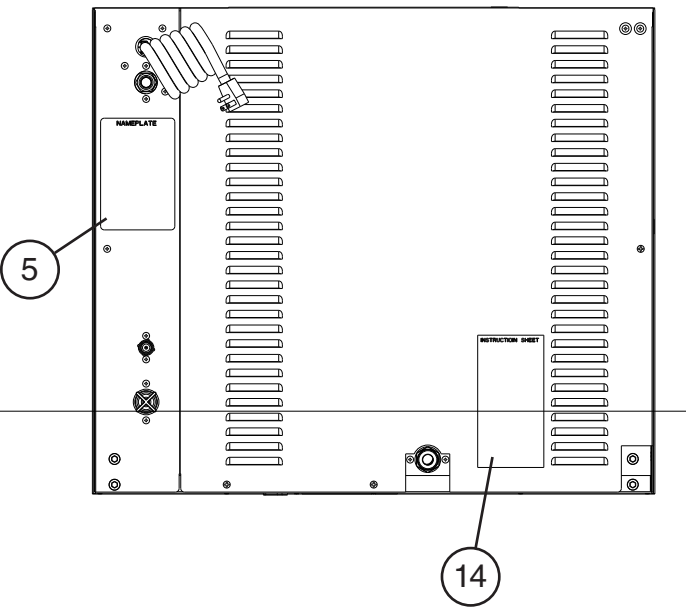
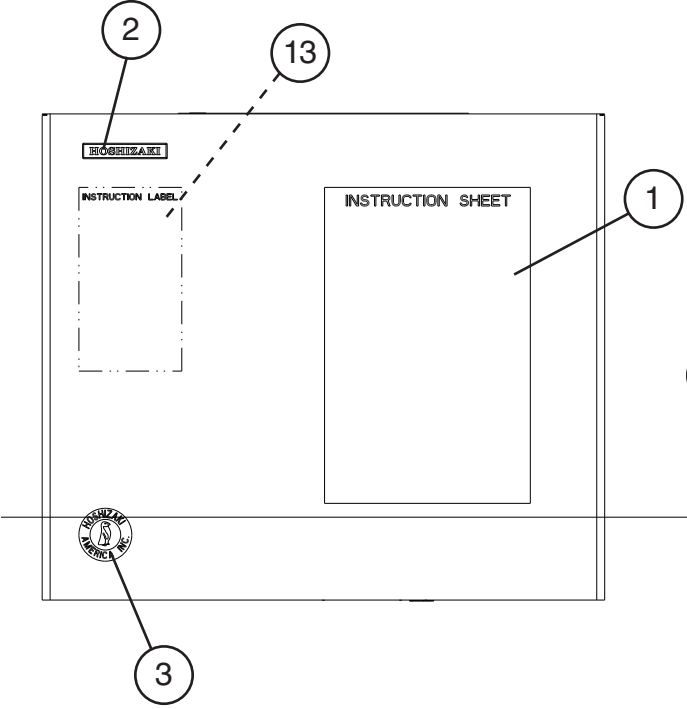
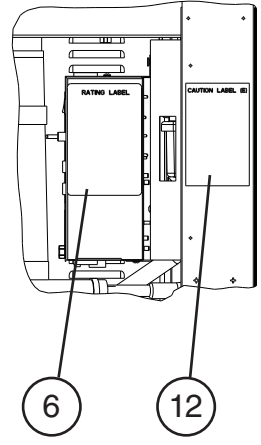
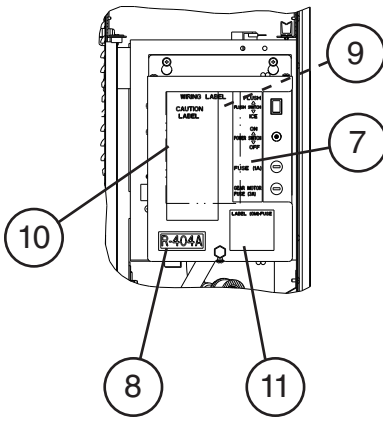
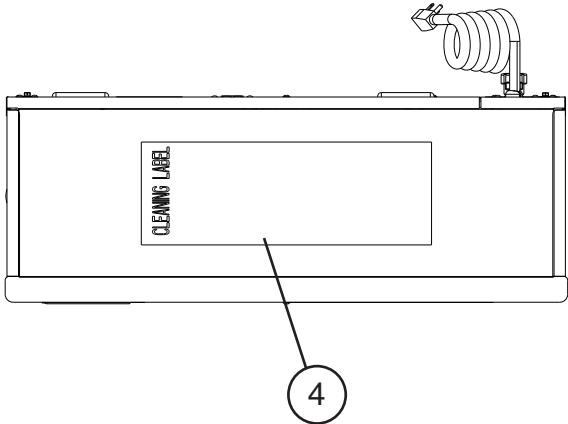

Title: **G. Label Location** Model: **FS-1001MLH-C**

Index No.	Description	Material or Model Number	Part Number	Required Number									
				P-0 to S-0	T-0 to U-0	U-1 to A-0							
<b>Label Location</b>			2A3180A01	1	1	1							
<b>Order Assembly Parts Individually</b>													
1	Instruction Sheet		2A3222-01	1	1	-							
2	Emblem		4A0560-01	1	1	1							
3	Penguin-HA-R Label		4A0526-01	1	1	1							
4	Cleaning Label		2A3445-01	1	1	1							
5	Nameplate		3A3241-01	1	1	1							
6	Rating Label		3A3242-01	1	1	1							
7	Control Label		4A2234-01	1	1	1							
8	R-404A Label		4A0960-01	1	1	-							
9	Wiring Label		3A3505-01	1	1	-							
			3A5548-01			1							
10	Caution Label		4A3932-01	1	1	1							
11	Fuse Label (GM)		4A2835-01	1	-								
			4A4278-01		1	1							
12	Caution Label (E)		439145-01	1	1	1							
13	Instruction Label		326371-01	1	1	1							
14	Instruction Sheet		433523-01	1	1	1							

## H. Accessories & Packaging

### FS-1001MLH-C

P-0 to A-0

Title: H. Accessories & Packaging    Model: FS-1001MLH-C													
Index No.	Description	Material or Model Number	Part Number	P-0 to A-0	Required Number								
1	Instruction Manual		91A2PB10B	1									
2	Bracket		4A3668-01	2									
2a	Hex Bolt	5x12, SS	7B02-0512	4									
2b	Self-Tapping Bolts		7P1111234	4									
	Packaging		1A1046A01										