

Use & Care Guide
Ice Maker

Guia de Uso y Cuidado
Máquina de hielo

Guide d'utilisation et d'entretien
Machine à glaçons



 **Electrolux**

Please read and save this guide

Thank you for choosing Electrolux, the new premium brand in home appliances. This Use & Care Guide is part of our commitment to customer satisfaction and product quality throughout the service life of your new ice maker.

We view your purchase as the beginning of a relationship. To ensure our ability to continue serving you, please use this page to record key product information.

IMPORTANT

PLEASE READ all instructions completely before attempting to install or operate the unit.

All ice makers require a connection to both a water supply and an electrical power source. Improper hook-up can result in substantial property damage! Proper installation, in accordance with the manufacturer's specifications and all local codes, is the sole responsibility of the consumer. The manufacturer is not responsible for any installation expenses or damages incurred due to improper installation. If you are unsure of your ability to safely make electric power, water supply, and water drain connections to the unit, consult licensed and insured professionals to perform all electrical and plumbing work.

Once you have your unit installed, we suggest you keep this manual in a safe place for future reference. Should any problems occur, refer to the Troubleshooting section of this manual. This information will help you quickly identify a problem and get it remedied. In the event you require assistance, please contact the dealer where you purchased your unit.

Keep a record for quick reference

Whenever you call to request information or service, you will need to know your model number and serial number. You can find this information on the serial plate located on the inside wall of your unit and on the product registration card.



NOTE

Registering your product with Electrolux enhances our ability to serve you. You can register online at www.electroluxusa.com or by dropping your Product Registration Card in the mail.

Please record the purchase date of your Electrolux unit and your dealer's name, address and telephone number.

Purchase Date

Electrolux Model Number

Electrolux Serial Number

Dealer Name

Dealer Address

Dealer Telephone

Keep this manual and the sales receipt together in a safe place for further reference.

Questions?

For toll-free telephone support in the U.S. and Canada: 1-877-4ELECTROLUX (1-877-435-3287)

For online support and product information visit <http://www.electroluxusa.com>

Table of Contents

Finding Information	2	Operation	14
Please read and save this guide.....	2	Normal Operation	14
Keep a record for quick reference.....	2	Ice Cube Thickness.....	14
Questions?.....	2	Ice Dispenser Operation and Care.....	14
Table of contents.....	3	Ice Cube Thickness Adjustment.....	15
		Drain Pump.....	15
Safety	4	Maintenance	16
Important Safety Instructions	4	Special Considerations	16
Safety Precautions.....	4	Maintaining and Cleaning Your Ice Maker.....	16
Definitions	4	Exterior Cleaning - As Required.....	16
General Precautions	4	Stainless Steel Models.....	16
		Interior Cleaning - As Required	16
Installation	5	Condenser Cleaning - Every 3 Months.....	17
Installation Dimensions	5	Self Cleaning - Every 6 Months.....	17
Installing the Drain.....	5	Inlet Screen Cleaning - Every Year	19
Gravity Drain.....	5		
Connecting a Drain Pump.....	6	Storing, Vacation and Moving	19
		Draining for Non-Use.....	19
Site Preparation	7	Troubleshooting	20
Preparing the Site	7	Before you Call for Service.....	20
		If Service is Required.....	21
Water Supply Connection	8	Warranty Information	22
Connecting the Water Supply.....	8		
Leveling	9		
Leveling the Unit.....	9		
Door Reversal	10		
Reversing the Door (some models)	10		
Adjusting the Door	12		
Built-In Installation / Start-Up	13		
Installing a Built-In.....	13		
Initial Start-Up	13		
Blackout Mode.....	13		
Normal Operating Sounds	13		



WARNING

You must follow these guidelines to ensure that your refrigerator's safety mechanisms are operating correctly.

Important Safety Instructions

Safety Precautions

Do not attempt to install or operate your unit until you have read the safety precautions in this manual. Safety items throughout this manual are labeled with a Danger, Warning or Caution based on the risk type.

Definitions

This is the safety alert symbol. It is used to alert you to potential personal injury hazards. Obey all safety messages that follow this symbol to avoid possible injury or death.

DANGER

DANGER indicates an imminently hazardous situation which, if not avoided, will result in death or serious injury.

WARNING

WARNING indicates a potentially hazardous situation which, if not avoided, could result in death or serious injury.

CAUTION

CAUTION indicates a potentially hazardous situation which, if not avoided, may result in minor or moderate injury, product damage, or property damage.

IMPORTANT

Indicates installation, operation or maintenance information which is important but not hazard related.

General Precautions

DANGER

RISK OF CHILD ENTRAPMENT. Before you throw away your old appliance, take off the doors and leave shelves in place so that children may not easily climb inside.

IMPORTANT

To turn off power to your ice maker, unplug the power cord from the wall outlet.

WARNING

- Never attempt to repair or perform maintenance on the unit until the electricity has been disconnected.
- Altering, cutting of power cord, removal of power cord, removal of power plug, or direct wiring can cause serious injury, fire and/or loss of property and/or life and will void the warranty.
- Do not lift unit by door handle.

CAUTION

- Use care when moving the unit. Some edges are sharp and may cause personal injury. Wear gloves when moving or repositioning the unit.
- Never install the unit behind closed doors. Be sure front grille is free of obstruction. Obstructing free air flow can cause the unit to malfunction, and may void the warranty.
- Allow unit temperature to stabilize for 24 hours before use.
- Never use an ice pick or other sharp instrument to help speed up defrosting. These instruments can puncture the inner lining or damage cooling unit
- Failure to clean the condenser every three months can cause the unit to malfunction. This could void the warranty.

CAUTION

- Using a heater to speed up defrosting can cause personal injury and damage to the inner lining. **DO NOT** use any type of heater to defrost.
- Use only genuine Electrolux replacement parts. Imitation parts can reduce ice rate, cause water to overflow from ice maker mold, damage the unit, and may void the warranty.

Installation Dimensions

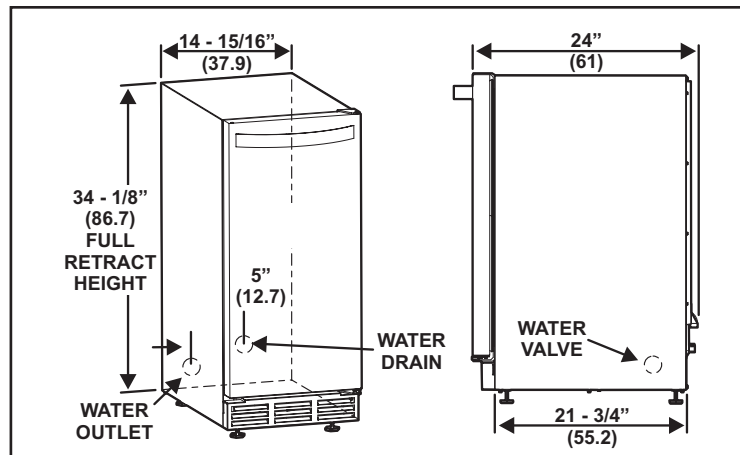

Installing the Drain

CAUTION

PLEASE READ all instructions completely before attempting to install or operate the unit. All ice makers require a connection to the water supply and improper hook-up can result in substantial property damage! All water and drain connections **MUST BE** made by a licensed/qualified plumbing contractor. Failure to follow recommendations and instructions may result in damage and/or harm.

CAUTION

Plumbing installation must observe all state and local codes. All water and drain connections **MUST BE** made by a licensed/qualified plumbing contractor. Failure to follow recommendations and instructions may result in damage and/or harm.

Model EI15IM55GS can be installed using a gravity drain or the Electrolux EIMP60, optional drain pump kit.

Follow these guidelines when installing drain lines to prevent water from flowing back into the ice maker storage bin and/or potentially flowing onto the floor causing water damage:

Gravity Drain

- Drain lines must have a 5/8 inch inside diameter.

- Drain lines must have a 1 inch drop per 48 inches of run (1/4 inch per foot) and must not create traps.
- The floor drain must be large enough to accommodate drainage from all drains.
- Insulate the bin drain line to prevent condensation.

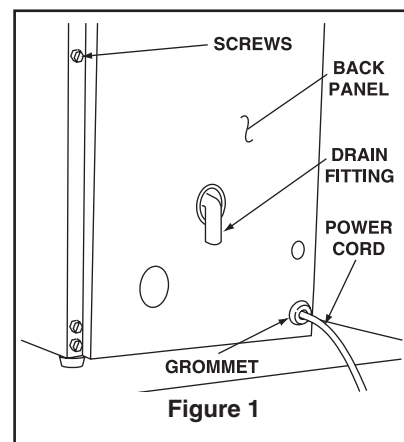

Figure 1

Connecting a Drain Pump

If a gravity drain connection is not available, we strongly recommend the use of the Electrolux EIMP60 drain pump. The Electrolux EIMP60 drain pump is available through your Dealer, or direct from Electrolux with complete installation instructions. If a pump other than the Electrolux EIMP60 drain pump is to be used, it must meet the following specifications:

- It must be UL listed and have a UL listed, 120 VAC, 3-wire grounded power cord.
- It must have overall maximum outside dimensions of 8-3/4" wide x 5-3/4" deep x 7-3/4" high.
- It must have a minimum flow rate of 15 gallons per hour at 10 feet of lift.
- It must have a sealed sump which does not allow water leakage in the case of a power outage, restricted drain or pump failure.
- It must have a check valve in the discharge line to prevent waste water return to the pump.
- It must have an overflow protection control which will shut off power to the ice maker in the event of a pump failure.
- It must have an operating temperature range of 50°F to 110°F (10°C to 43°C).



CAUTION

In the event of a power outage, restricted drain or pump failure, the failure to use the Electrolux EIMP60 drain pump or a pump with the above listed specifications, could result in substantial water leakage and pooling with severe and costly water damage and related consequential damages and harm.

Preparing the Site

→ IMPORTANT

It is extremely important that the unit is level. If it is not level, the ice mold will not fill evenly. This can cause a reduction in ice rate, uneven sized cubes or water spilling into the storage area which will cause the ice in the bin to melt prematurely. Remember that floors near drains have a tendency to slope towards the drain.

- 1 Position the unit on a flat, level surface, capable of supporting the entire weight of the unit. Remember that the unit will be significantly heavier once it is fully loaded.
- 2 The surrounding air temperature must be at least 50°F (10°C) but must not exceed 110°F (43°C).
- 3 The unit must not be located near heat-generating equipment or in direct sunlight.

⚠ DANGER

ELECTROCUTION HAZARD!

Electrical Grounding Required. This appliance is equipped with a three prong (grounding) polarized plug for your protection against possible shock hazards.

- NEVER remove the round grounding prong from the plug.
- NEVER use a two-prong grounding adapter.
- NEVER use an extension cord to connect power to the unit.

Where a two-prong wall receptacle is encountered or a longer power cord is required, contact a qualified electrician to have it replaced in accordance with applicable electrical codes.

- 4 The unit must be located to allow clearance for water, drain and electrical connections in the rear of the ice maker.
- 5 Connect the unit to a grounded and polarized 115 VAC, 60 Hz, 15 A circuit (normal household current).
- 6 Avoid connecting the unit to a Ground Fault Interruptor (GFI). GFIs are prone to nuisance tripping which will cause the unit to shut down. GFIs are generally not used on circuits which power equipment that must run unattended for long periods of time.

- 7 The unit must be installed according to your local codes and ordinances.

🗨 NOTE

The door of the unit may be mounted on either side of the cabinet (see REVERSING THE DOOR). All units require zero clearance when installed flush with a cabinet or wall (see Figure 2). Electrolux stainless steel models require a minimum 2-3/4 inch handle clearance when installed against a wall or cabinet that extends beyond the front edge of the unit (see Figure 3).

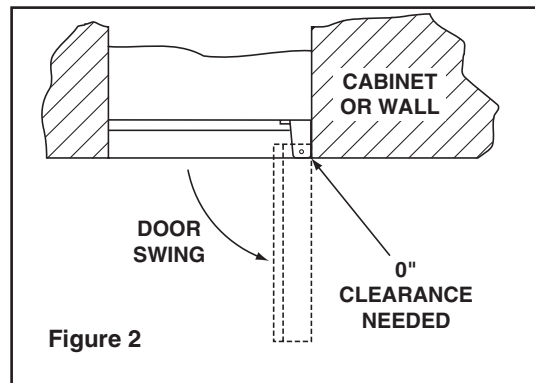

Figure 2

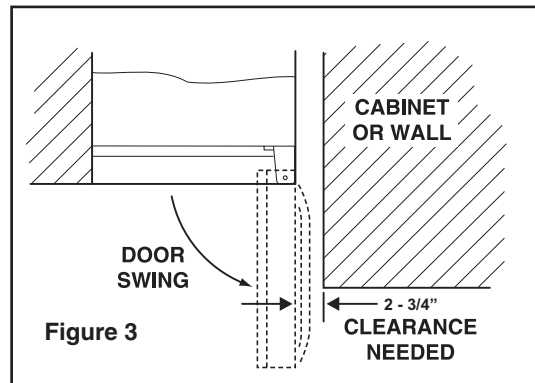

Figure 3

- 8 Position the unit to allow free air flow through the front grille (see Figure 4).
- 9 Wipe out inside of unit with a damp cloth.

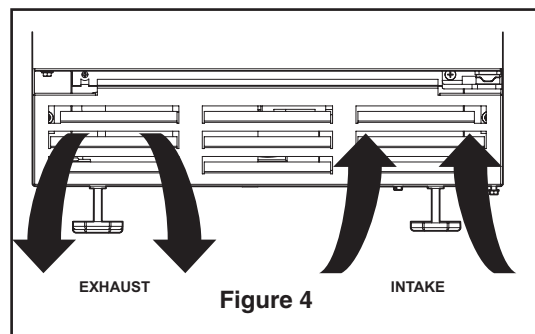

Figure 4

8 Water Supply Connection

Connecting the Water Supply

When connecting the water supply, follow these guidelines:

- Review the local plumbing codes before you install the unit.
- The water pressure should be between 30 and 120 psi.

CAUTION

If you are using a filter system you will need to have at least 20 psi for 3 minutes every 15 minutes.

- Make certain a SHUT-OFF VALVE is installed in the 1/4 inch water supply line.
- Connect sufficient tubing to the unit to allow the unit to be moved for cleaning and servicing. However, make certain that the tubing is not pinched or damaged during installation.
- Electrolux recommends the use of copper tubing for installation. **DO NOT** use plastic water supply line since it may crack or rupture with age and may cause water damage to your house.

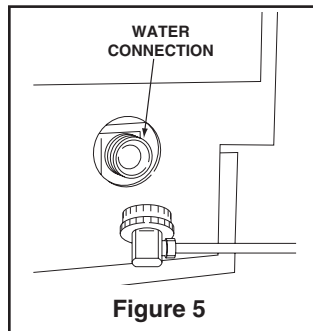

- 1 Locate the compression fitting and ferrule packed in the unit. Slide the compression fitting and ferrule over the 1/4 inch water supply line. Do not use thread sealing compound or tape. Using two wrenches, tighten the compression fitting on the supply line (see Figure 6).
- 2 Carefully bend the water supply line into position and connect the line to the solenoid valve. Avoid kinking the water supply line.
- 3 For recessed installations, allow extra water supply line length to provide slack for easy removal from the recessed area (see Figure 8). This will also safeguard against kinking the line.

CAUTION

After completing the installation, turn on the water and recheck water and drain connection for leaks. Apply additional tightening if needed. Do NOT use thread sealing compound or tape.

- 4 Plug in the power cord.
- 5 Gently push the unit into position. If desired the unit may be recessed into cabinet or wall.
- 6 Allow at least 1-1/2 inches clearance behind the unit for electrical, water supply and drain connections.

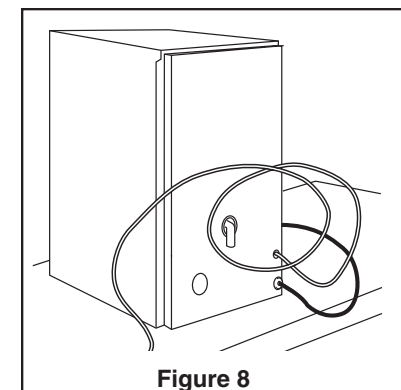
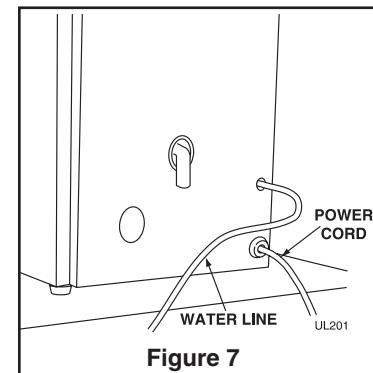
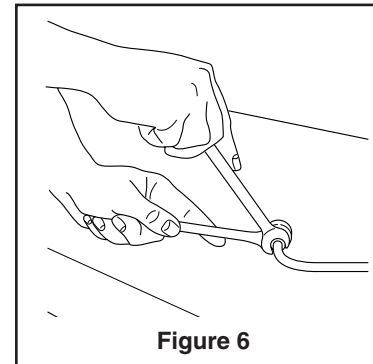

Leveling the unit

- 1 Use a level to check the levelness of the ice maker from front to back and from side to side (see Figure 10).

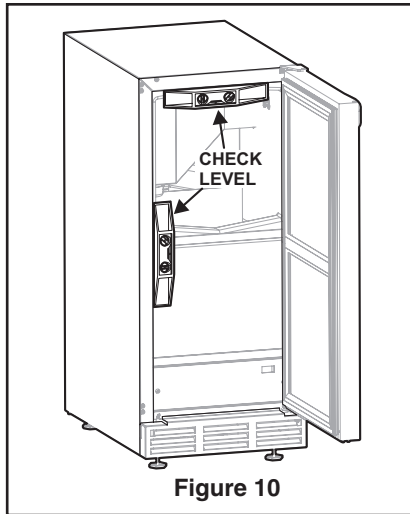

- 2 If the ice maker is not level, adjust the feet on the corners of the unit as necessary (see Figure 11).

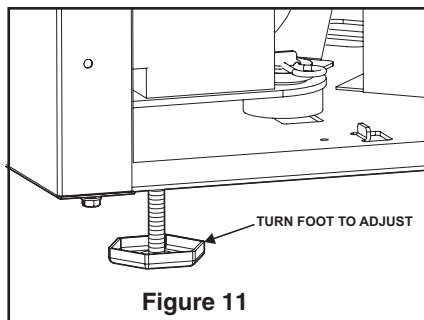

- 3 Check the levelness after each adjustment and repeat the previous steps until the unit is level.

Reversing the Door (some models)

All Electrolux units may be left or right hand opening. The door opening is easily reversed by moving the hinge hardware to the opposite side (see Figure 12).

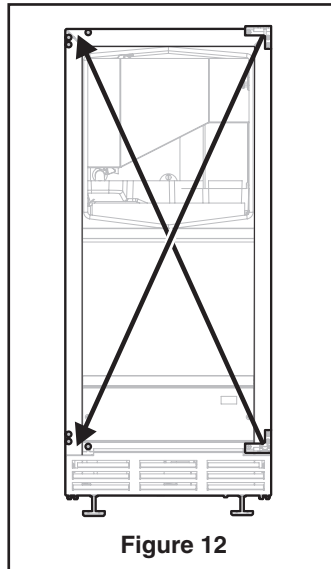

To reverse the door:

- 1 Remove top hinge screw pin from cabinet using a Phillips® head screwdriver (see Figure 13). Remove door by tilting forward and lifting off bottom hinge pin.

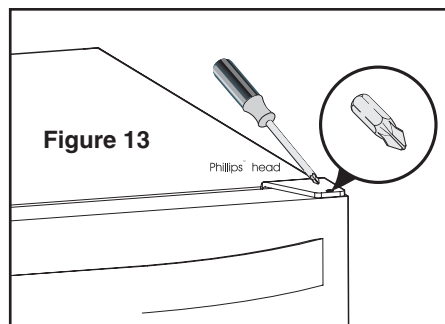

- 2 Remove plastic screw plugs (3 top and 3 bottom) from new hinge location (see Figure 14), and remove hinge pin hole plug in top of door (see Figure 15). Do not discard.

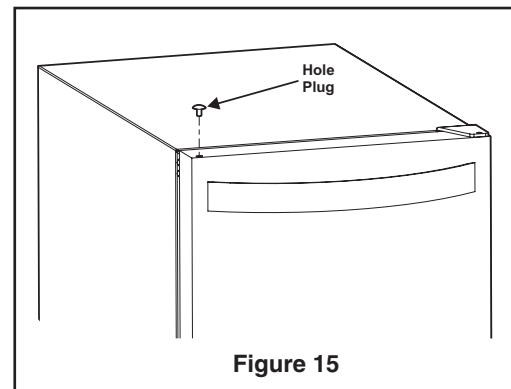
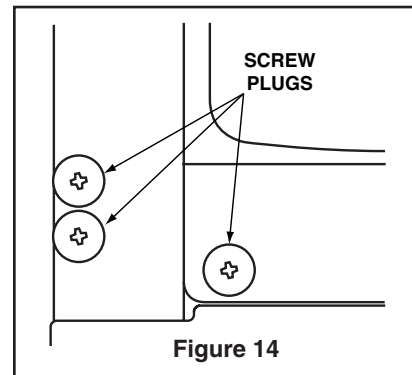

- 3 Remove top hinge (3 screws), reinstall hinge screw pin, and remount on opposite side BOTTOM (see Figure 16).

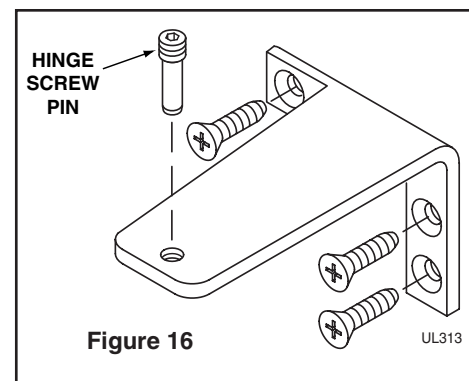

- 4 Remove the two door closer inserts from the existing bottom hinge and install as shown on the new bottom hinge (see Figure 17).

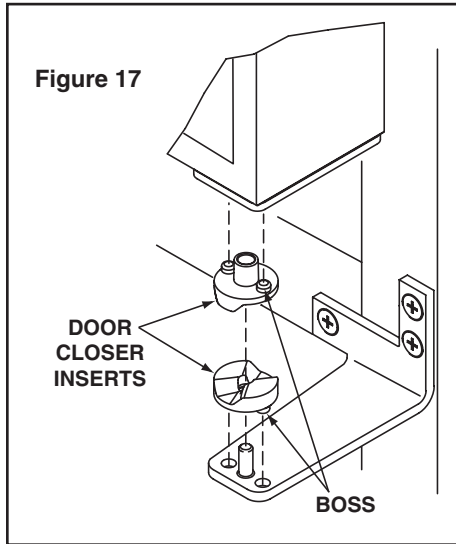

- 5 Remove existing bottom hinge (3 screws) and remount on opposite side TOP. Remove hinge screw pin.
- 6 With bottom of door facing up, remove pivot plate (2 screws), flip over, and remount on opposite side of door (see Figure 18).

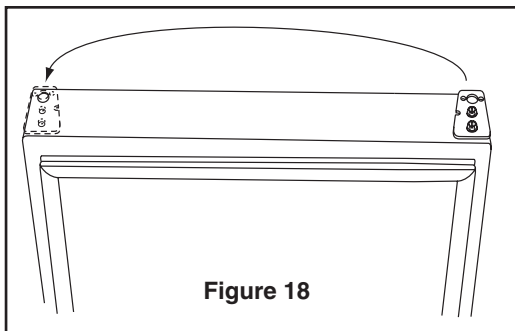

- 7 Holding door upright with top of door tilted forward, place hole of door pivot plate on bottom hinge screw pin (see Figure 19). Be sure that the bosses on the closers align with holes in hinge and hinge plate.

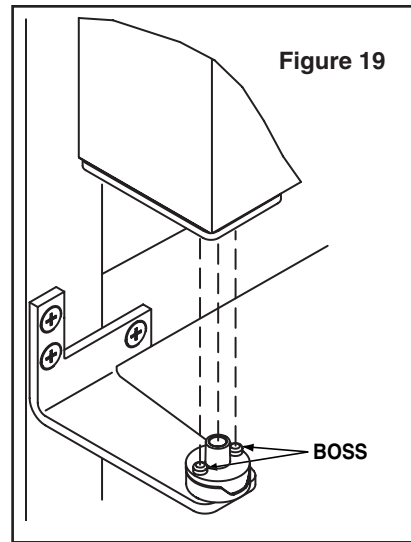

- 8 Tilt top of door into position in top hinge and install top hinge screw pin.
- 9 In empty hinge holes, install plastic screw plugs (3 top and 3 bottom) and door hole plug (1, door top) removed in step 2.

Adjusting the Door

Your door is aligned at the factory before shipment. Occasional re-adjustment may be necessary, especially if an overlay panel is installed. The following procedure will correct for up to 1/4" alignment.

The door should never be flush with the top of the cabinet. Even when level, the top edge of the door will be 1/8" below the top of the cabinet (see Figure 20).

To adjust :

- 1 Compare the top edge of the door (opposite the hinges) to the top edge of the cabinet and note the type of adjustment (up or down) needed.
- 2 Remove the top hinge pivot pin with a Phillips® head screwdriver (see Figure 21) and lift door off bottom hinge pin. Be careful not to lose door closers (see Figure 23).
- 3 With door upside-down, loosen but do not remove the two hinge plate screws.

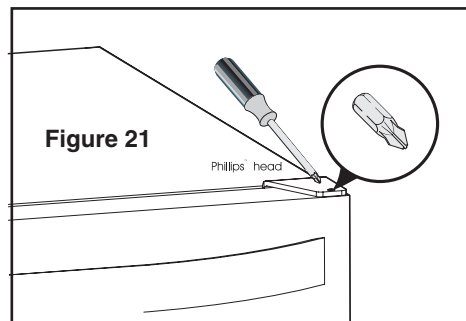
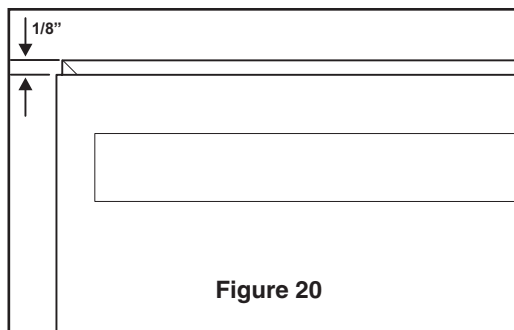

- 4 If door edge opposite the hinges needs to move up, move plate toward outside of door. If door edge needs to move down, move plate toward inside of door (see Figure 22). Repeat until top edge of door is parallel with top of cabinet and tighten screws securely.

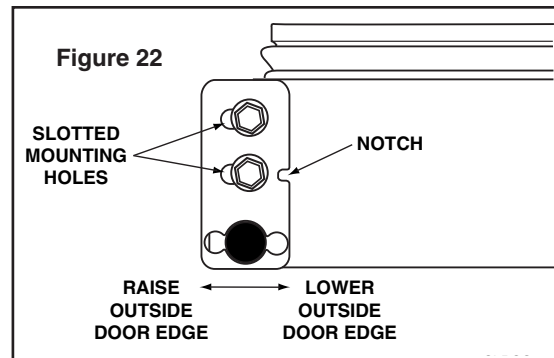

- 5 After adjustment is complete, remove the door closers from the bottom hinge, clean thoroughly and apply petroleum jelly to the mating surfaces of the closers (see Figure 23). Be sure that bosses on closers align with holes in hinge and hinge plate. Mount door and install top hinge pivot pin.

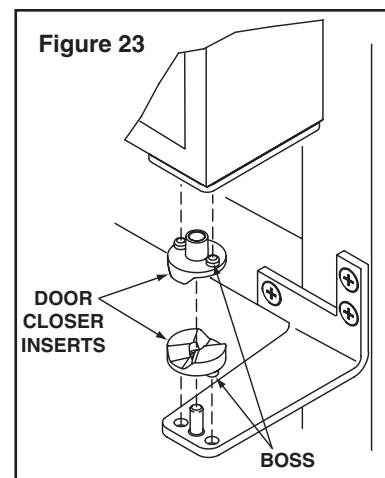

Installing a Built-In

Your Electrolux product has been designed for either free-standing or built-in installation. When built-in, your ice maker does not require additional air space for top, sides or rear. However, the front grille must NOT be obstructed.

NOTE

To ease unit installation and removal, the unit must be located to allow clearance for water, drain and electrical connections in the rear of the ice maker.

Built-In Cabinet Dimensions			
Model	Unit Dimensions		
	Width	Height	Depth
EI15IM55GS	14-15/16"	34-1/8"	24"

CAUTION

DO NOT install unit behind closed doors.

Initial Start-Up

Once installation and leveling is complete, the unit is ready for initial start-up and operation. All units are shipped with controls that are preset. No initial adjustments are required.

IMPORTANT

It is possible that dirt or scale will dislodge in the water line. Always throw away all ice cubes made during the first two to three hours of operation.

Plug into a 115 volt polarized and grounded electrical outlet.

Open the water supply valve at the main water source.

To turn the unit on or off, touch and hold the POWER button on the display panel for approximately five seconds, then release.

- A small LED above the icon will illuminate to confirm the touch of any controller icon.
- The electronic display will show "ICE" when the unit is on, and "OFF" when the unit is off.
- Turning the unit off will override any other control function.

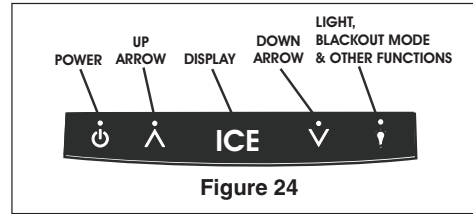

Figure 24

Blackout Mode (not Star-K certified)

1. Touch and hold the LIGHT button for ten seconds, then release (the °F symbol will flash briefly at the end of the ten second period).
2. The control display will go dark for 36 hours.
3. To exit the Blackout Mode, repeat step 1.

Normal Operating Sounds

All models incorporate rigid foam insulated cabinets to provide high thermal efficiency and maximum sound reduction for it's internal working components. In spite of this technology, your model may make sounds that are unfamiliar.

Normal operating sounds may be more noticeable because of the unit's environment. Hard surfaces such as cabinets, wood/vinyl/tiled floors and paneled walls have a tendency to reflect normal operating noises.

Common refrigeration components and a brief description of the normal operating sounds they make are listed below. **NOTE:** Your unit may not contain all the components listed.

- **Compressor:** The compressor makes a hum or pulsing sound that may be heard when it operates
- **Evaporator:** Refrigerant flowing through an evaporator may sound like boiling liquid.
- **Condenser Fan:** Air moving through a condenser may be heard.
- **Automatic Ice Maker:** You will hear ice as it drops from the mold into the ice bin/tray.
- **Water Valve:** The water valve will make an occasional buzzing sound and running water will be heard.

Normal Operation

The ice maker is designed to make clear ice from most water sources on a consistent basis. Water is constantly circulated over the evaporator assembly. As the water freezes, gravity causes any sediment to drop into the water trough and not become imbedded in the ice. This gives a clearer ice cube with a low mineral content. When the ice reaches the desired thickness, it falls off the evaporator and into the storage bin. The cycle is then repeated. When the level of ice reaches the top of the storage bin the unit shuts off. As the ice level in the bin drops the unit will automatically restart to keep the bin full. Your unit's ice production rate may vary depending on many considerations. Ambient air temperatures, water temperatures, condenser cleanliness and ice-maker cleanliness are all contributing factors to how quickly the unit produces ice. Certain sounds are normal during the unit's operation. You may hear the compressor or fan motor, the water valve, the water circulation pump or ice dropping into the ice storage bin.

Ice Cube Thickness

Your Electrolux ice maker uses advanced technology to make ice that is crystal clear. This technology cascades a flow of water over a chilled ice mold that is mounted vertically so no water sits in it. Because of this ice making technology, clear ice cubes differ significantly from regular ice cubes. Differences are illustrated in Figure 25.

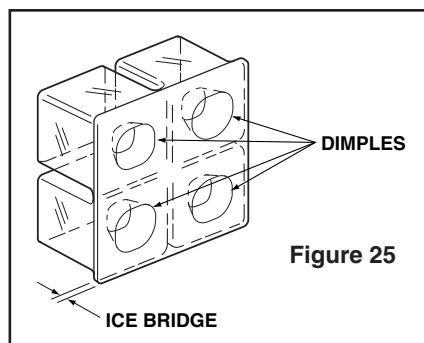

- **Dimples:** Electrolux clear ice cubes have “dimples” on one side from the cascading water process.
- **Cube Variations:** Cubes made from different batches, or even cubes within the same batch may have varying dimples, thickness and/or sizes due to the cascading water process.

- **Cube “slabbing”:** Electrolux clear ice makers produce a “slab” of ice that falls from the vertical mold, relying on gravity to break the ice bridges. Depending on the control setting, and the fullness of the ice bucket, it may be necessary to tap the ice slab with the ice scoop to break it apart.

Ice Dispenser Operation & Care

The ice cube thickness control is factory set for best overall performance. The factory setting is designed to maintain an ice bridge of approximately 1/16” to 1/8” under normal conditions resulting in a dimple of approximately 1/4” to 1/2” in depth (see Figure 26a and 26b). A fuller cube with less of a dimple results in a thicker ice bridge. As the ice bridge becomes thicker, the tendency for the cubes to stay together as a slab increases. A bridge thicker than 1/8” may cause cubes to over-fill the ice bucket.

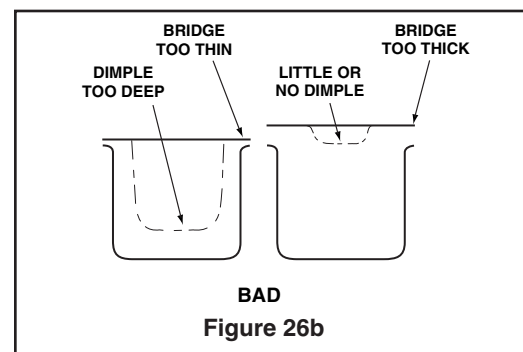
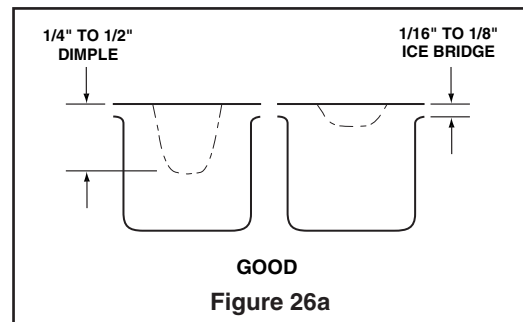

Ice Cube Thickness Adjustment

Interval - As Required

Ice thickness adjustments are made using the control panel as follows:

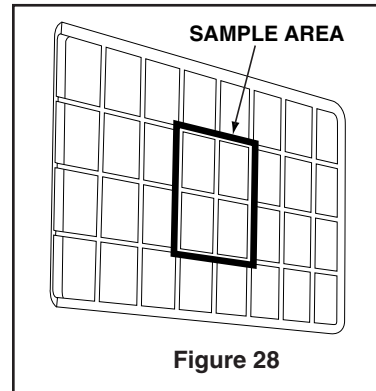
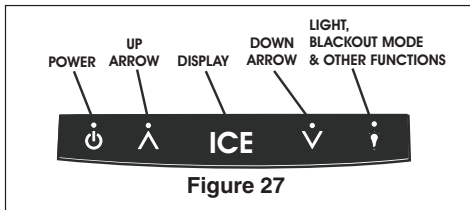

1. To enter the thickness adjustment mode:
 - a. Touch and hold the UP ARROW button.
 - b. Touch and release the DOWN ARROW button three times, then release the UP ARROW button.
 - c. The display will switch to "0," to confirm the thickness adjustment mode has been selected.
2. The factory setting is "0," and the total range of adjustment is -5 to +5. Use the UP ARROW button to raise the setting and thicken the ice bridge, or the DOWN ARROW button to lower the setting to thin the ice bridge.

➔ IMPORTANT

Ice thickness adjustment should only be made one increment at a time. Allow ice maker production to stabilize for 24 hours before rechecking ice thickness.

3. Touch and release the LIGHT button key to exit the ice thickness adjustment mode.
4. Remove all ice from the storage bin.
5. Ice cubes in any given batch will vary, so it is necessary to choose cubes from the sample area (Figure 28) for comparison when making adjustments. If further adjustments are desired, repeat steps 1 through 4.

➔ IMPORTANT

It is extremely important that Clear Ice models are level. If not level, the ice mold will not fill evenly.

Special Considerations

- For best performance, keep the unit out of direct sunlight.
- Turn the unit OFF and dispose of any ice cubes if the unit will not be used for 5 days or more. Prop door open to allow for air circulation and prevent mold and mildew.
- If the ambient temperature is expected to drop below 45°F (7°C), drain all water from the unit to prevent freezing damage not covered by the warranty.
- High ambient temperatures, 110°F (43°C) or higher, may reduce the unit's ability to reach low temperatures and may also reduce the ice production rate.

Maintaining and Cleaning Your Icemaker

Periodic cleaning and proper maintenance will ensure efficiency, top performance, and long life. The maintenance intervals listed are based on normal conditions. You may want to shorten the intervals if you have pets or other special considerations.

Exterior Cleaning - As Required

The door, grille and cabinet may be cleaned with a mild detergent and warm water solution. Do not use solvent based or abrasive cleaners.

Use a soft sponge and rinse with clean water. Wipe with a soft, clean towel to prevent water spotting.

Stainless Steel Models

- Stainless steel models may discolor when exposed to chlorine gas, pool chemicals, salt water or cleaners with bleach.
- Keep your stainless unit looking new by cleaning with a high quality, all-in-one stainless steel cleaner/polish on a monthly basis. Frequent cleaning will remove surface contamination that could lead to rust. Some installations will require cleaning on a weekly basis.
- DO NOT CLEAN WITH STEEL WOOL PADS.
- DO NOT USE CLEANERS THAT ARE NOT SPECIFICALLY INTENDED FOR STAINLESS STEEL (this includes glass, tile and counter cleansers).

- If any surface discolors or rusting appears, clean it quickly with Bon-Ami or Barkeepers Friend Cleanser and a non-abrasive cloth. Always clean in the direction of the grain. Always finish this process with a high quality, all-in-one stainless steel cleaner/polish to prevent further problems.
- USE OF ABRASIVE PADS SUCH AS SCOTCHBRITE WILL CAUSE THE GRAINING IN THE STAINLESS TO BECOME BLURRED.
- Rust that is allowed to linger can penetrate into the surface of the stainless steel and become impossible to remove.



CAUTION

Stainless steel models exposed to chlorine gas and moisture, such as areas with spas or swimming pools, may have some discoloration of the stainless steel. Discoloration from chlorine gas is normal. Follow exterior cleaning instructions.

Interior Cleaning - As Required

- 1 Disconnect power to the ice maker.
- 2 Open the door and remove any ice from the storage bin.
- 3 Wipe down the interior and storage bin with a solution of non-abrasive mild soap or detergent and warm water. Rinse with clean water.
- 4 Sanitize the bin with a solution of 1 tablespoon of bleach in 1 gallon of warm water. Rinse thoroughly with clean water.
- 5 Check that all drain connections are in place.



CAUTION

- DO NOT use solvent cleaning agents or abrasives on the interior. These cleansers may transmit taste to the ice cubes, or damage or discolor the interior.
- DO NOT use any cleaner on the evaporator plate other than Ice Machine Cleaner. **Other cleaners may affect ice quality, or cause damage to the unit that is not covered under warranty. See AUTOMATIC CLEAN CYCLE for more information.**

- 6 Reconnect power to the unit.

Condenser Cleaning — Every 3 Months

To maintain operational efficiency, clean the condenser every three months (depending on environmental conditions, more or less frequent cleaning may be necessary).

WARNING

Disconnect electric power to the ice maker before cleaning the condenser.

To remove and replace the grille for access to the condenser fins follow this procedure (see Figure 29):

- 1 Remove the screws at each end of the grille.
- 2 Remove the grille.

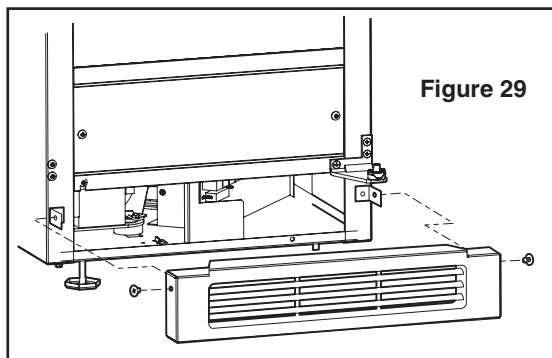

WARNING

DO NOT touch the condenser fins. The condenser fins are SHARP. The fins can also be easily damaged.

CAUTION

DO NOT use any type of cleaner on the condenser unit.

- 3 Clean the condenser coil using a brush with a “combing” action, or a vacuum cleaner. Do not touch the condenser coil.
- 4 Clean the grille, then position the grille to align the screw holes with the cabinet.
- 5 Insert the grille screws and tighten. Do not over tighten.

Self Cleaning — Every 6 Months

To maintain operational efficiency, clean the unit every six months (depending on water conditions more or less frequent cleaning may be necessary). If the ice maker requires more frequent cleaning, consult a qualified plumber to test the water quality and recommend appropriate treatment.

WARNING

Wear rubber gloves and safety goggles and/or face shield when handling Ice Machine Cleaner.

CAUTION

Use only Electrolux Ice Machine Cleaner (part number EIM30046).

It is a violation of Federal law to use this solution in a manner inconsistent with its labeling. Use of any other cleaner can ruin the finish of the evaporator and will void the warranty.

Read and understand all labels printed on the package before use.

Ice machine cleaner is used to remove lime scale and other mineral deposits. Refer to the following steps for mineral deposit removal.

CAUTION

Never use anything to force ice from the evaporator. Damage may result.

- 1 Turn the ice maker off (allowing any ice to melt off of the evaporator) as follows:
 - a Touch and hold the POWER button.
 - b The display will switch from ICE to OFF to confirm that the ice maker is off. (See Figure 30.)

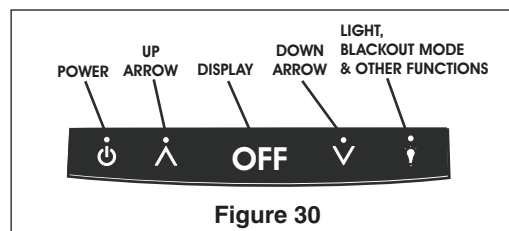

- 2 Remove all ice from the storage bin.
- 3 Remove inside front cover. (See figure 31.)

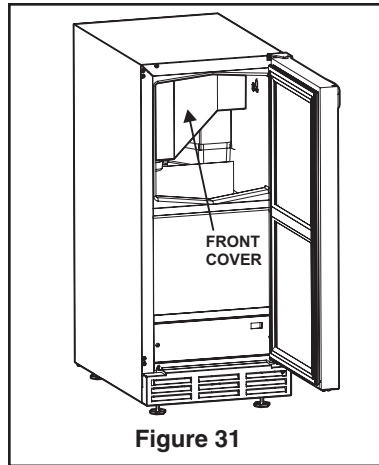

Figure 31

4. Remove the overflow tube by lifting it while using a slight back and forth motion to loosen it from the drain hole. The water in the reservoir will flow down the drain. (See figure 32.)

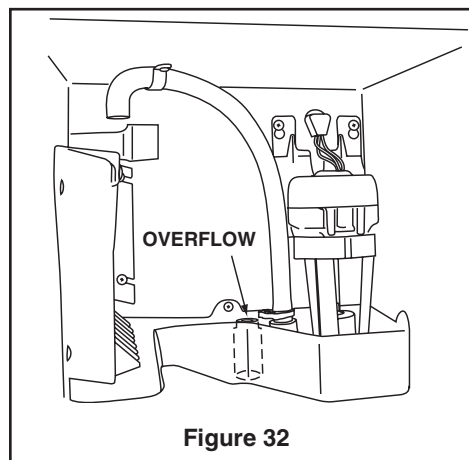

Figure 32

- 5 Replace the overflow tube after all of the water has drained from the reservoir.
- 6 Start the cleaning cycle as follows:
 - a Touch and hold the POWER button.
 - b Touch and release the LIGHT button three times, then release the POWER button.
 - c The display will show "CL" to confirm the beginning of the cleaning cycle.
- 7 When water begins to flow over the evaporator (approximately 3 minutes), add one package of Electrolux Ice Machine Cleaner to the water reservoir.

- 8 Reinstall inside front cover.
- 9 When the self-cleaning process stops (approximately 45 minutes) the unit will remain off for an additional 15 minutes. When the clean cycle is completed, the display will automatically switch back to set temperature and unit will run as normal operation.
- 10 Clean the storage bin. (See INTERIOR CLEANING). Sanitize the bin with a solution of 1 tablespoon of bleach and 1 gallon of warm water. Rinse thoroughly with clean water.
- 11 To ensure the drain system is working properly, pour 1 gallon of cool, fresh water into the ice bin. The water should drain freely. If the unit is equipped with a drain pump, it should drain the ice bin.

When ice production resumes, the water fill valve will energize, fill the water reservoir, and shut-off after three minutes. The compressor begins to operate and water flows over the evaporator assembly (ice cube tray). Initially, the water flow may not be uniform, causing uneven sized cubes or water to spill into the ice storage bin. This is a normal situation that will correct itself within the first 24 hours of operation.

➔ IMPORTANT

- Discard all ice produced in the first harvest.
- If power gets interrupted during the self-clean cycle, it will be necessary to repeat the complete cleaning cycle after power is restored.

Inlet Screen Cleaning — Every Year

The solenoid valve inlet screen must be cleaned at least once each year as follows:

- 1 Shut off the water at the water supply valve.
- 2 Pull the unit out to access the back panel.
- 3 Disconnect electrical power to the unit.
- 4 Disconnect the entire hose connector from the water solenoid valve (see Figure 33).
- 5 Use a tooth brush to clean sediment from the inlet screen. DO NOT remove the screen.
- 6 Re-connect the water supply line to the water solenoid valve. Tighten connector securely. Open the water supply valve and check for leakage at the water connection. Make sure the water supply line is not kinked.
- 7 Reconnect power to the unit before re-installing.
- 8 Make sure the drain system is working properly and the drain hose is not pinched or kinked. Pour one gallon of cool, fresh water into the ice bin. The water should drain freely. If your ice maker is equipped with a drain pump, the pump should drain the ice bin.

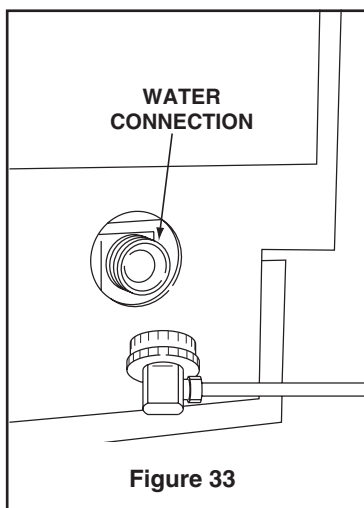

Draining for non-use

If the unit is to be stored, moved or not used for extended periods, it will be necessary to drain the system of water.

WARNING

Electrical Shock Hazard. Disconnect power before servicing. Before operating replace all panels. Failure to do so can result in death or electrical shock.

- 1 Disconnect power from the unit.
- 2 Remove ice from the storage bin.
- 3 Shut off water supply at the main water source.

NOTE

Back panel must be removed prior to disconnecting the water lines.

- 4 Disconnect the inlet and outlet lines to the water valve and allow them to drain.

CAUTION

If the ambient temperature is expected to drop below 45°F (7°C), drain all water from the unit to prevent freezing damage, which is not covered by the warranty.

IMPORTANT

The use of antifreeze or other products of this nature is not necessary and is not recommended.

- 5 Reconnect inlet and outlet lines to the water valve.
- 6 Replace back panel.
- 7 Drain water from the water trough and drain line by removing the overflow tube (see Figure 32).
- 8 Clean the ice maker and storage bin before next use.
- 9 Prop door open to allow for air circulation and prevent mold and mildew.

IMPORTANT

It is possible that dirt or scale will dislodge in the water line. Always throw away all ice cubes made during the first 24 hours of operation when the unit is returned to service.

Before You call For Service

If the unit appears to be malfunctioning, read through Normal Operation first. If the problem persists, check the Troubleshooting Guide. Locate the problem in the guide and refer to the cause and its remedy before calling for service. The problem could be something very simple which can be solved without a service call.



DANGER

ELECTROCUTION HAZARD

NEVER attempt to repair or perform maintenance on the unit until the main electrical power has been disconnected.

Troubleshooting Guide

Troubleshooting – What to check when problems occur

Problem	Possible Cause	Remedy
Unit does not operate.	<ul style="list-style-type: none"> No electrical power to the unit. Cycle selector switch set improperly. Low air temperature around unit. 	<ul style="list-style-type: none"> Make sure power cord is plugged in. Check for blown fuse or tripped circuit breaker. Make sure cycle selector switch is set to ICE/ON. Surrounding air temperature must be at least 45°F (7°C).
Unit runs but no ice is produced.	<ul style="list-style-type: none"> No water being supplied to the unit. 	<ul style="list-style-type: none"> Check to see that water is connected and turned on to the unit.
Unit runs but produces very little ice.	<ul style="list-style-type: none"> Dirty condenser coils. High air temperature around unit. Scale and mineral buildup in unit. Inadequate airflow at the front of the unit. Cleaning cycle recently performed 	<ul style="list-style-type: none"> Clean the condenser. See Maintenance. Surrounding air temperature of over 90°F (32°C). Low ice production at high temperatures is normal. Clean unit. See Maintenance. Remove items blocking airflow. Allow unit to reach the set temperature to produce ice normally
Ice is slow to release or does not release from the evaporator.	<ul style="list-style-type: none"> Ice-making system is dirty. Unit is not level. Low air temperature around the unit. 	<ul style="list-style-type: none"> Run unit through automatic clean cycle. See Maintenance. See Leveling the Unit. Surrounding air temperature must be at least 50°F (10°C).

Troubleshooting – What to check when problems occur

Problem	Possible Cause	Remedy
Poor ice quality (soft or unclear).	<ul style="list-style-type: none"> Poor incoming water quality. Ice-making system is dirty. 	<ul style="list-style-type: none"> Consult a qualified plumber to test the water quality and recommend appropriate treatment. Run unit through automatic clean cycle. See Maintenance.
Unit produces shallow or incomplete cubes, or the ice fill pattern on the evaporator is incomplete.	<ul style="list-style-type: none"> Low water level. Hot incoming water. Incorrect incoming water pressure. Unit is not level. 	<ul style="list-style-type: none"> Check to see that overflow tube is fully seated. Connect the unit to a cold water supply. See Installation. Water pressure must be 20-120 psi. See Leveling the Unit.
Water leaking from under the unit.	<ul style="list-style-type: none"> Supply line leaking. Fill tube leaking. Bin drain leaking. 	<ul style="list-style-type: none"> Check to see that the water inlet line is attached to inlet valve properly. See Connecting the Water Supply. Check connection at water valve outlet. Check integrity of bin drain hose and clamp.
Ice storage bin full of water.	<ul style="list-style-type: none"> Obstructed drain. 	<ul style="list-style-type: none"> Check to see that storage bin drain opening is free from obstruction and debris.
Electronic display is blank with door OPEN	<ul style="list-style-type: none"> A display function has changed. 	<ul style="list-style-type: none"> Touch and hold the UP ARROW button and touch and release the POWER button three times, then release the UP ARROW button. The display should become visible.
Electronic display shows repeating, randomly flashing symbols and partial characters.	<ul style="list-style-type: none"> A factory control mode has been inadvertently entered. 	<ul style="list-style-type: none"> Touch and hold the UP ARROW button and touch and release the LIGHT button three times, then release the UP ARROW button and exit the factory control mode.
Electronic display shows one or more of the following: E1, E2, E4, E5, E6, E7, E8, E9, E10, P1	<ul style="list-style-type: none"> The unit is displaying an error code. 	<ul style="list-style-type: none"> Record the error code(s) displayed and call for service

If Service is required

If the need for service arises, contact the dealer from whom the unit was purchased. State the Model Number and Serial Number and explain the problem. The Model and Serial Number plate is located inside the unit at the upper right hand corner.

If you do not know the name of the selling dealer or local service company, you can check online at www.electroluxusa.com, or call 877-435-3287.

ICE MAKER WARRANTY *Your ice maker is protected by this warranty*

	WARRANTY PERIOD	THROUGH OUR AUTHORIZED SERVICERS, WE WILL:	THE CONSUMER WILL BE RESPONSIBLE FOR:
FULL ONE-YEAR WARRANTY	One year from original purchase date.	Pay all costs for repairing or replacing any parts of this appliance which prove to be defective in materials or workmanship.	Costs of service calls that are listed under NORMAL RESPONSIBILITIES OF THE CONSUMER.*
LIMITED 2ND- 5TH YEAR WARRANTY (Cabinet Liner and Sealed System)	Second through fifth years from original purchase date.	Repair or replace any parts in the cabinet liner or sealed refrigeration system (compressor, condenser, evaporator, dryer or tubing) which prove to be defective in materials or workmanship.	Costs for pickup and delivery of the appliance required because of service. Costs for labor, parts and transportation other than with respect to the cabinet liner or sealed refrigeration system.
LIMITED WARRANTY (Applicable to the State of Alaska)	Time periods listed above.	All of the provisions of the full warranties above and the exclusions listed below apply.	Costs of the technician's travel to the home and any costs for pick up and delivery of the appliance required because of service.

In the U.S.A., your appliance is warranted by Electrolux Home Products, Inc. We authorize no person to change or add to any of our obligations under this warranty. Our obligations for service and parts under this warranty must be performed by us or an authorized Electrolux Home Products, Inc. servicer. In Canada, your appliance is warranted by Electrolux Canada Corp.

*NORMAL RESPONSIBILITIES OF THE CUSTOMER

This warranty applies only to products in ordinary household use, and the consumer is responsible for the items listed below:

1. Proper use of the appliance in accordance with instructions provided with the product.
2. Proper installation by a licensed and insured professional, in accordance with instructions provided with the appliance and in accordance with all local plumbing, electrical and/or gas codes.
3. Proper connection to a grounded power supply of sufficient voltage, replacement of blown fuses, repair of loose connections or defects in house wiring.
4. Expenses for making the appliance accessible for servicing, such as removal of trim, cupboards, shelves, etc., which are not a part of the appliance when it was shipped from the factory.
5. Damages to finish after installation.
6. Replacement of light bulbs and/or fluorescent tubes (on models with these features).

EXCLUSIONS

This warranty does not cover the following:

1. CONSEQUENTIAL OR INCIDENTAL DAMAGES SUCH AS PROPERTY DAMAGE AND INCIDENTAL EXPENSES RESULTING FROM ANY BREACH OF THIS WRITTEN OR ANY IMPLIED WARRANTY.
Note: Some states do not allow the exclusion or limitation of incidental or consequential damages, so this limitation or exclusion may not apply to you.
2. Service calls which do not involve malfunction or defects in workmanship or material, or for appliances not in ordinary household use. The consumer shall pay for such service calls.
3. Damages caused by services performed by servicers other than Electrolux Home Products, Inc., Electrolux Canada Corp., or its authorized servicers; use of parts other than genuine Electrolux Home Products parts; obtained from persons other than such servicers; or external causes such as abuse, misuse, inadequate power supply or acts of God.
4. Products with original serial numbers that have been removed or altered and cannot be readily determined.

IF YOU NEED SERVICE

Keep your bill of sale, delivery slip, or some other appropriate payment record. The date on the bill establishes the warranty period should service be required. If service is performed, it is in your best interest to obtain and keep all receipts. This written warranty gives you specific legal rights. You may also have other rights that vary from state to state. Service under this warranty must be obtained by contacting Electrolux Home Products, Inc. or Electrolux Canada Corp.

This warranty only applies in the 50 States of the U.S.A. and Puerto Rico, and Canada. Product features or specifications as described or illustrated are subject to change without notice. All warranties are made by Electrolux Home Products, Inc. In Canada, your appliance is warranted by Electrolux Canada Corp.

USA

877-435-3287

Electrolux Home Products, Inc.
P.O. Box 212378
Augusta, GA 30917

Canada

866-213-9397

Electrolux Canada Corp.
6150 McLaughlin Road
Mississauga, Ontario
L5R 4C2