

INSTALLATION INSTRUCTIONS

FOR ADAPTER KIT P/N 629096828

This adapter kit is recommended for use with Cold Fusion Dispensers and Icemakers that measure 30" wide X 24.5" deep. The icemaker drop zone and bin stat must fit within the footprint shown in figure 1.

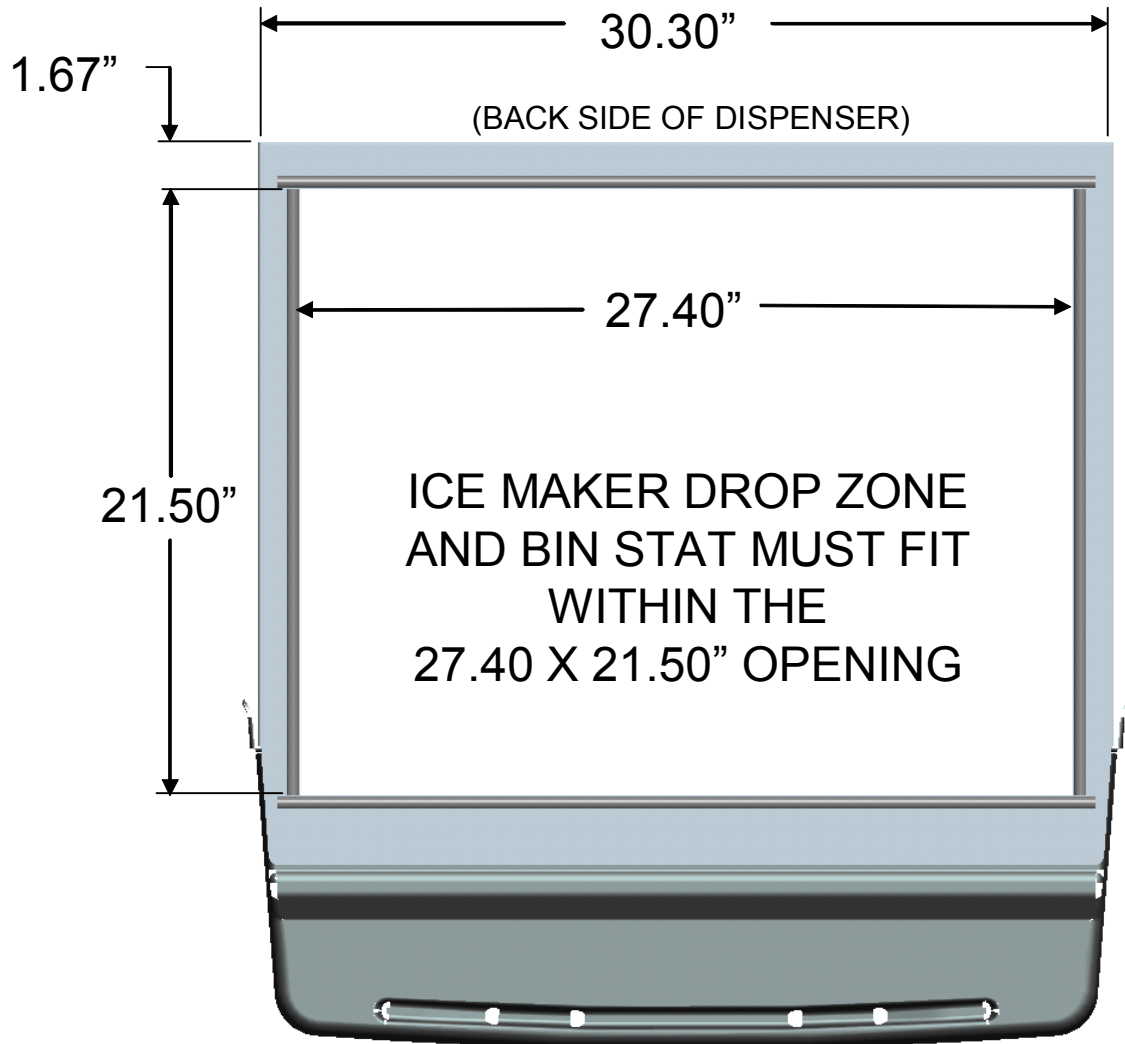

Figure 1

⚠ WARNING:

Disconnect power to the unit before installing adaptor following all lock out / tag out procedures established by the user. Verify all of the power is off to the unit before performing any work. Failure to comply could result in serious injury, death or damage to the equipment.

⚠ WARNING:

All of the attachment screws and plates must be installed as directed in this manual. Failure to comply could result in serious Injury, Death or Damage to the equipment.

1. First step is to position and secure the kit to the dispensing unit. Whenever possible, this should be done prior to lifting the dispenser onto the counter to allow sufficient access and also provide easier and faster installation.

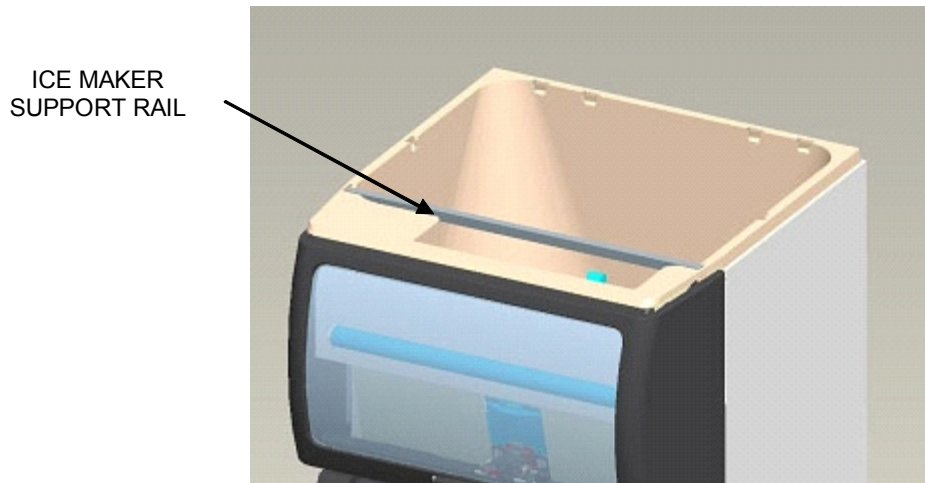

Figure 2

2. Place ice maker support rail into the front set of pockets in the ice bin as shown in Figure 2.
3. Position the adapter kit onto the drink dispenser so that it is pulled as far forward as it can be. The gaskets on the inside of the kit (that rest on the hopper) must also be compressed as far down as they can go. One design feature of the kit is to support the weight of the icemaker. The support rails (internal to the kit) resting on the hopper provide this support. Therefore, compressing the gaskets replicate the weight of the icemaker and should be done prior to drilling any holes, as mentioned in the next step.
4. Using the four holes in the adapter cover as templates, drill 9/64" (.140" Dia.) holes in the sides of the dispenser (2 holes per side). **USE EXTREME CAUTION NOT TO DRILL INTO ANY OTHER COMPONENTS.** Maximum drill depth from the face of the kit should not exceed 3/8" (just enough to go through the material being drilled). Remember, the kit should be all the way forward and compressed down before drilling the holes. Otherwise, undesirable gaps may result (lid to merchandiser) and the internal latch feature for the lid may not function properly. After holes are drilled, secure the kit to the machine using the screws provided (refer to Figure 3).

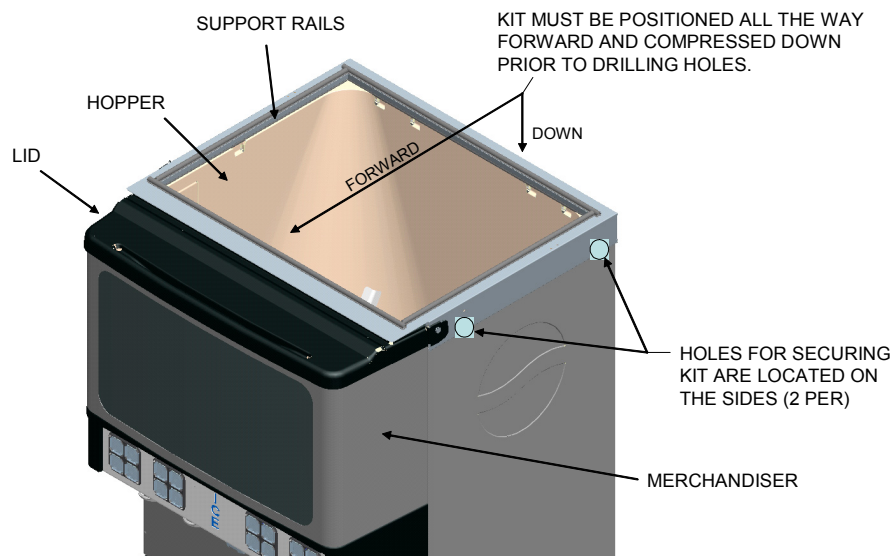

Figure 3

5. When ready, lift the machine onto the counter.
6. Position the icemaker on top of the kit. Do not slide the icemaker into position. This may tear the gasket material on top. Instead, lift and position the icemaker into place. The back side of the icemaker should line up with the back of the kit. Side walls should also be centered from left to right. Connect the icemaker according to the manufacturer's requirements.
7. Apply a continuous bead of silicone (supplied) around the icemaker to seal it to the kit. (For reference - Silicone is NSF International Listed Silastic Sealant, Dow 732 or equivalent).
8. The next step is to secure the icemaker to the kit. Use the brackets (supplied) as templates to drill four 9/64" (.140" Dia.) holes into the adapter kit (2 per side). When drilling holes, the maximum distance from the back of the kit is 7.50 inches (refer to Figure 4) . Failure to comply will result in damage to the sliding arm mechanisms internal to the kit. Drill four holes of the same diameter into the icemaker (2 per side). Ensure the location of the brackets will not damage the kit or the icemaker prior to drilling any holes. **USE EXTREME CAUTION NOT TO DRILL INTO ANY OTHER COMPONENTS.** Drill depths should not go further than the thickness of the material being drilled (just enough to go through). Secure the two brackets using the screws provided.

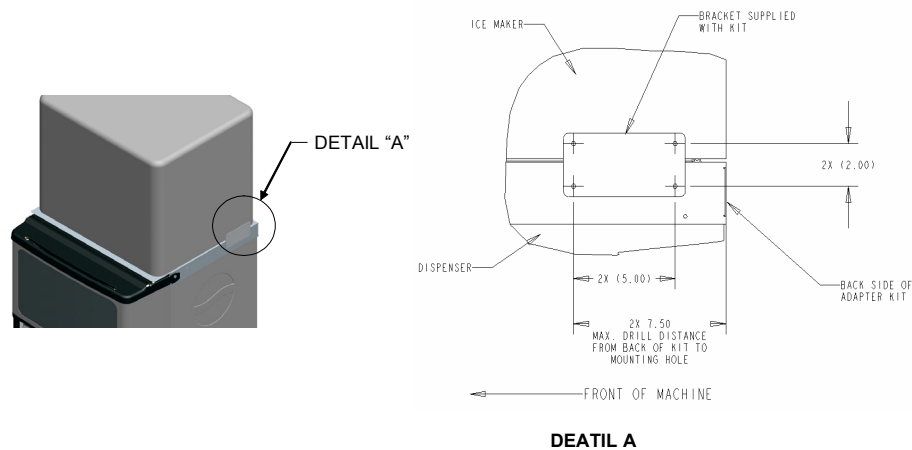

Figure 4

Installation is complete. For optimal performance, Do not fill ice bin to more than 2/3 of capacity. Recommended maximum fill height is four (4) inches from the top of the bin.

Adapter Kit Operating Instructions

1. The plastic lid of the kit slides in and out and also hinges upward. This provides access to the hopper in the event manual ice filling is required. Simply pull out the lid and hinge upward. The lid will remain in the up position on its own.
2. If manual filling is required, the lid must be pulled out and lifted up out of the way. Do not leave the lid down and rest a bucket of ice on it while manual filling as this may cause damage to the lid.



- COMPLETED ASSEMBLY –
COLD FUSION DISPENSER WITH ADAPTER KIT
P/N 629096828, AND 30" X 24.5" ICE MAKER

Figure 5