

# **Bravetti™**

## **Cool Touch Deep Fryer**

### **OWNER'S MANUAL**

Model F2015H / F2015HR / F2015HL / F2015HB  
120V., 60Hz., 1500 Watts

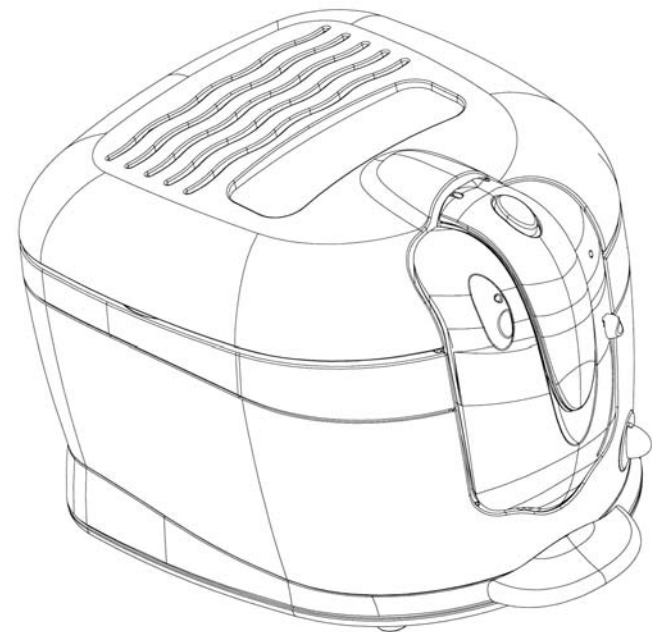

**EURO-PRO Operating LLC**

U.S.: 94 Main Mill Street, Door 16  
Plattsburgh, NY 12901

Canada: 4400 Bois-Franc  
St-Laurent, QC H4S 1A7

Tel. : 1 (800) 798-7398

# IMPORTANT SAFETY INSTRUCTIONS

When using electrical appliances, basic safety precautions should always be followed, including the following:

1. Read all instructions for use carefully and look at the illustrations before you start using the appliance.
2. Do not touch hot surfaces, always use handles or knobs.
3. To protect against electrical shock, do not immerse cord and plug of this appliance in water or other liquids.
4. Close supervision is necessary when any appliance is used by or near children.
5. Unplug from outlet when not in use and before cleaning. Allow to cool before putting on or taking off parts and before cleaning the appliance.
6. Do not operate any appliance with a damaged cord or plug, or after the appliance malfunctions, has been dropped or damaged in any manner. Return the appliance to **EURO-PRO Operating LLC** for examination, repair or adjustment. See warranty.
7. Never plug in before the control panel is installed in the body of the fryer and the heating element is placed in the oil container.
8. Never overfill the fryer with oil. Fill only between the minimum and maximum levels, as indicated inside the oil container.
9. Be sure handle is properly assembled to the basket and locked in place. See detailed assembly instructions.
10. The use of accessory attachments not recommended by the appliance manufacturer may cause injuries.
11. Always insert heating element in the appliance first, then plug into the wall outlet. To disconnect, remove plug from wall outlet then wait for the unit to cool completely before removing the heating element.
12. Extreme caution must be used when moving any appliance containing hot oil or other hot liquids.
13. Do not leave appliance unattended while in use.
14. Do not use outdoors.
15. Do not let cord hang over the edge of the table, counter or touch hot surfaces.
16. Do not place on or near a hot gas or electric burner, or in a heated oven.
17. Do not use appliance for other than intended household use.

## SPECIAL SAFETY INSTRUCTIONS

- A detachable magnetic power cord is provided to reduce the risk resulting from becoming entangled in or tripping over a longer cord. **An extension cord (or longer detachable cord) is not recommended for use with deep fryers.**
- **Never** plug in the unit to an electrical outlet before the control panel is installed into the body of the fryer with the heating element inside the oil container.
- Do not immerse the control panel and heating element in water.
- When opening the lid after frying, lift it slowly and wait a moment to allow the steam inside to escape before opening fully.
- To avoid a circuit overload, do not operate another high wattage appliance on the same circuit.

### POLARIZED PLUG

**WARNING:** To reduce the risk of electric shock, this appliance has a polarized plug (one blade is wider than the other). This plug will fit in a polarized outlet only one way. If the plug does not fit fully in the outlet, reverse the plug. If it still does not fit, contact a qualified electrician to install the proper outlet. Do not modify the plug in any way.



## SAVE THESE INSTRUCTIONS FOR HOUSEHOLD USE ONLY

Models  
F2015H  
F2015HR  
F2015HL  
F2015HB

**EURO-PRO**

## ONE (1) YEAR LIMITED WARRANTY

**EURO-PRO Operating LLC** warrants this product to be free from defects in material and workmanship for a period of one (1) year from the date of the original purchase, when utilized for normal household use, subject to the following conditions, exclusions and exceptions. If your appliance fails to operate properly while in use under normal household conditions within the warranty period, return the complete appliance and accessories, freight prepaid to:

**U.S.:** **EURO-PRO Operating LLC**, 94 Main Mill Street, Door 16, Plattsburgh, NY 12901  
**Canada:** **EURO-PRO Operating LLC**, 4400 Bois Franc, St. Laurent, QC H4S 1A7

If the appliance is found to be defective in material or workmanship, **EURO-PRO Operating LLC** will repair or replace it free of charge. Proof of purchase date and \$ 18.95 to cover the cost of return shipping and handling must be included. \*

Non-durable parts including, without limitation, paper bags, filters, brushes and electrical parts which normally require replacement are specifically excluded from warranty.

The liability of **EURO-PRO Operating LLC** is limited solely to the cost of the repair or replacement of the unit at our option. This warranty does not cover normal wear of parts and does not apply to any unit that has been tampered with or used for commercial purposes. This limited warranty does not cover damage caused by misuse, abuse, negligent handling or damage due to faulty packaging or mishandling in transit. This warranty does not cover damage or defects caused by or resulting from damages from shipping or repairs, service or alterations to the product or any of its parts, which have been performed by a repair person not authorized by **EURO-PRO Operating LLC**.

This warranty is extended to the original purchaser of the unit and excludes all other legal and/or conventional warranties. The responsibility of **EURO-PRO Operating LLC** if any, is limited to the specific obligations expressly assumed by it under the terms of the limited warranty. **In no event is EURO-PRO Operating LLC** liable for incidental or consequential damages of any nature whatsoever. Some states do not permit the exclusion or limitation of incidental or consequential damages, so the above may not apply to you.

This warranty gives you specific legal rights, and you may also have other rights which vary from state to state or from province to province.

**\*Important: Carefully pack item to avoid damage in shipping. Be sure to include proof of purchase date and to attach tag to item before packing with your name, complete address and phone number with a note giving purchase information, model number and what you believe is the problem with item. We recommend you insure the package (as damage in shipping is not covered by your warranty). Mark the outside of your package "ATTENTION CUSTOMER SERVICE". We are constantly striving to improve our products, therefore the specifications contained herein are subject to change without notice.**



## FOR CANADIAN CONSUMERS ONLY OWNERSHIP REGISTRATION CARD

Please fill out and mail the product registration card within ten (10) days of purchase. The registration will enable us to contact you in the unlikely event of a product safety notification. By returning this card you acknowledge to have read and understood the instructions for use, and warnings set forth in the accompanying instructions.

Canada: **EURO-PRO Operating LLC**, 4400 Bois Franc, St. Laurent, Québec H4S 1A7

**Model F2015H/F2015HR/F2015HL/F2015HB**

Appliance model

Date purchased

Name of store

Owner's name

Address

City

Prov.

Postal Code

## RECIPES

### Chicken Kiev

4 whole boneless, skinless chicken breasts    4 oz. butter, softened  
 1 tablespoon chopped onion                      4 oz. dry white bread crumbs  
 1 tablespoon parsley                                1/2 cup all-purpose flour  
 1 1/2 teaspoon salt                                  1 egg

Preheat oil to 360°F. Place chicken breast between two pieces of plastic wrap. Pound with wooden mallet to flatten chicken to 1/4 inch thick. Remove plastic. Combine onion, parsley and salt. Sprinkle chicken with mixture. Cut butter into 8 pieces. Place a piece of butter on seasoned chicken toward one end. Roll as jelly roll, starting at end with butter, tucking in sides of meat. Press to seal well. (No butter should be seen on the sides or coming from the chicken.) Secure with toothpicks. Dust with flour, dip into beaten egg. Then roll in bread crumbs. Chill rolls of chicken for at least one hour or until it has set. Place rolled chicken in a single layer in Frying Basket. Lower basket into preheated oil. Cook 5 to 7 minutes or until brown. To test for doneness, remove a piece of chicken from cooking oil. When a fork can be inserted with ease, chicken is done.

### Hush Puppies

1 3/4 cup cornmeal                                    1/2 teaspoon garlic salt (or 1/4 teaspoon  
 1/2 cup all-purpose flour                        garlic powder )  
 3/4 teaspoon baking soda                        1/2 cup chopped onion  
 1/2 teaspoon salt                                    1 cup buttermilk  
 1 teaspoon sugar                                   1 egg

Preheat oil to 375°F. Sift together cornmeal, flour, baking soda, salt, sugar and garlic salt (or powder). Combine egg and buttermilk, add to dry ingredients gradually, stirring until mixture is moist. Drop batter by teaspoonfuls into preheated oil (basket should already be lowered) frying a few at a time. Turn hush puppies once - if needed to evenly brown and cook until golden brown. Remove and drain on paper towels or food draining rack.

### Quick Doughnuts

1 10 count can of refrigerated can biscuits  
 2 tablespoons ground cinnamon  
 1/2 cup sugar

Preheat oil to 375°F. Remove biscuits from can. Take each biscuit and flatten slightly with palm of hand. Punch holes in center of each biscuit with your finger to shape into doughnuts. Fry 2 minutes - turning once or until brown. Remove from basket and drain on paper towels or food draining rack. Roll doughnut in mixture of cinnamon and sugar. Serve warm.

Try rolling doughnut in a mixture of 1 cup Ten X powdered sugar, 1/2 teaspoon vanilla and 4 tablespoon milk for a different treat. You may add more milk to achieve your desired consistency.

## GETTING TO KNOW YOUR DEEP FRYER

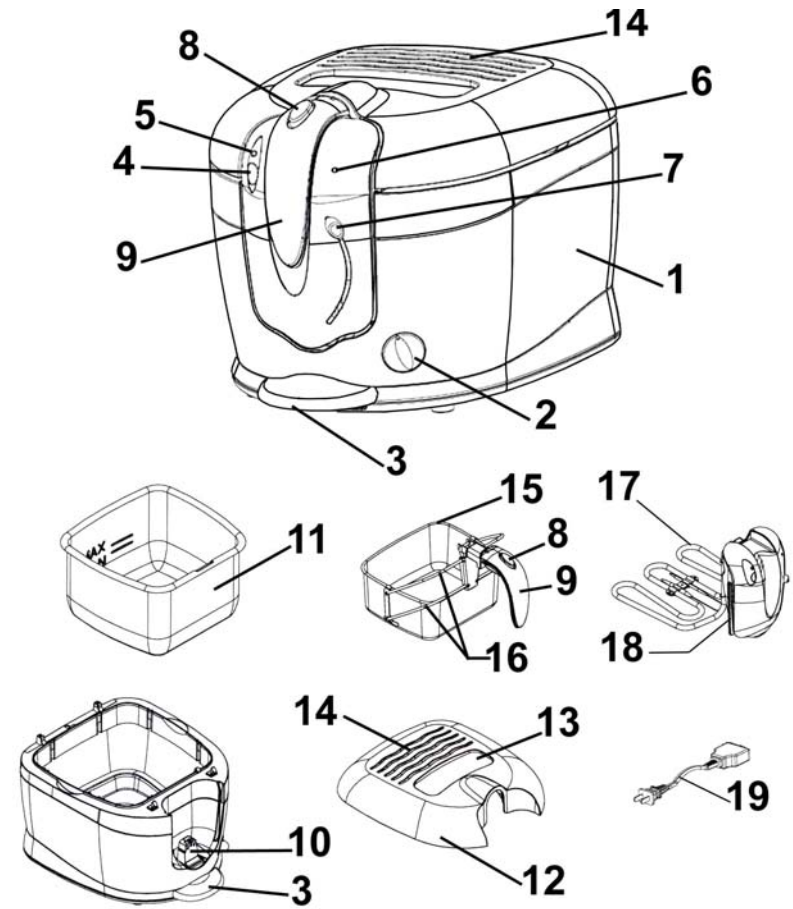

- |                            |                             |
|----------------------------|-----------------------------|
| 1. Main Unit               | 11. Oil Container/Reservoir |
| 2. 60-Minute Timer         | 12. Removable Cover         |
| 3. Cover Release Switch    | 13. Viewing Window          |
| 4. On/Off Button           | 14. Filter                  |
| 5. Power On Light          | 15. Frying Basket           |
| 6. Temperature Ready Light | 16. Basket Support Arms     |
| 7. Temperature Control     | 17. Heating Element         |
| 8. Handle Lock Button      | 18. Thermostat Reset Button |
| 9. Auto-lift Handle        | 19. Magnetic Power Cord     |
| 10. Power Junction Module  |                             |

### Technical Specifications

Voltage: 120V., 60Hz.  
 Power: 1500 Watts

## OPERATING INSTRUCTIONS

Read all the sections of this booklet and follow all the instructions carefully.

### **Before Using Your Deep Fryer**

Make sure the fryer is unplugged. Wash the frying basket and oil container in hot, soapy water. Wipe dry thoroughly. Wipe the removable heating control panel and heating elements with a damp, soapy cloth. Wipe dry thoroughly.

**NOTE:** Any water left in oil container or on frying basket can cause heated oil to splatter or “pop” during cooking. Special care should be taken to ensure that the oil filter in the removable cover is completely dry, otherwise the filter will not function properly. If not dry, steam may be trapped within the fryer during use and cause serious burns when opened.

### **Using for the First Time**

**Warning:** Never attach the magnetic power cord to the unit before the control panel is inserted into the unit with heating element in the oil container. Do not immerse the control panel, cord or plug in water.

**Note:** This unit should not be used to boil water.

### **Prior To First Use, Clean The Unit Thoroughly**

- All components with the exception of the electrical parts, can be washed in warm soap water. Dry thoroughly before use.
- Remove the cover from the unit.
- Press down on the handle lock button on the basket handle to raise the basket up and remove the basket assembly from the deep fryer. (Fig. 1)

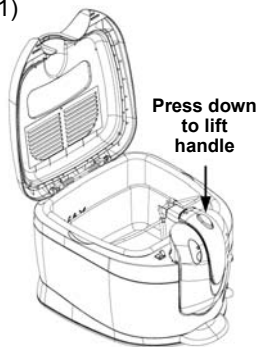

Fig. 1

- Lift the control panel up and remove from the unit. (Fig. 2)

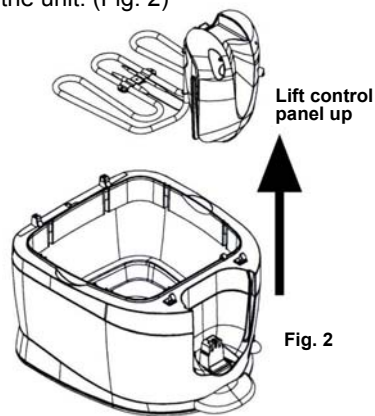

Fig. 2

- Remove the oil container.
- Clean the oil container and the frying basket with hot water, dishwashing liquid or other non-poisonous detergent and non-abrasive sponge.

**Caution:** All components must be completely dried before filling with oil and using. Special care must be taken to ensure the washable oil filter in the lid is completely dry, otherwise the filter will not function properly and may lead to steam being trapped within the fryer during use.

**Warning:** Never fill the frying basket more than half full with food.

## RECIPES

### Apple Fritters

3 cups all-purpose flour  
2 teaspoons baking powder  
1/2 teaspoon salt  
1 cup sugar  
1 egg, lightly beaten

4 tablespoons cooking oil  
1 teaspoon vanilla extract  
juice of 1 orange (1/3 cup)  
1 cup chopped apple

Preheat oil to 375°F. Combine flour, baking powder, salt and sugar; set aside. Combine egg, cooking oil and vanilla. Combine dry and liquid ingredients, stir to blend thoroughly. Add orange juice and apple, mix well. Drop from teaspoon into hot oil. (Basket should be lowered into oil so drop carefully - avoiding splattering oil). Fry approximately 2 minutes or until crisp and very brown. Remove from oil and drain. Dust with powdered sugar or a mixture of granulated sugar and cinnamon. Serve warm for best results. Try topping with a scoop of vanilla ice cream for an added treat.

### Beer Batter for Fish or Chicken

2 eggs (separated)  
1 tablespoon oil or butter  
1 teaspoon salt  
1/4 teaspoon ground black pepper

1 1/3 cup all-purpose flour  
3/4 cup flat beer  
Boneless chicken breasts (optional)  
Fish fillets or frying fish (optional)

Preheat oil to 360°F. Beat egg yolks with oil or butter, salt and pepper. Alternately add the beer and flour to the mixture. Beat ingredients well, refrigerate for 3 to 12 hours. When you are ready to use mixture, gently fold in 2 stiffly beaten egg whites. Pat fish or boneless chicken breasts to remove excess liquid. Coat lightly with flour then dip into beer batter. Place fish in hot carefully (basket should already be lowered into oil) and fry for 3 to 5 minutes or until golden brown. Fry chicken 5 to 10 minutes (depending on thickness) or until brown and fully cooked.

### Deep Fried Chicken

1 fryer chicken (2 to 3 lbs.)  
1 1/2 cup all-purpose flour  
1 teaspoon seasoned salt

1/4 teaspoon salt  
1/4 teaspoon garlic powder (optional)  
1/4 teaspoon poultry seasoning (optional)  
1 1/2 cup milk)

Preheat oil to 360°F. Combine flour and seasonings, mixing well. Dip or roll chicken in seasoned flour, dip into milk, and then flour again. Place into Frying Basket, lower basket into preheated oil. Fry for 15 to 20 minutes or until golden brown and fully cooked.



## OPERATION INSTRUCTIONS

### Suggested Temperature Settings

The following cooking times reflect only the approximate time needed to fry one basket 1/2 full. The exact time may be different depending on actual quantity, personal cooking preferences, size and thickness of pieces, etc. In general, use lower settings for delicate foods (vegetables, fish) and higher settings for frozen foods, French Fries and Chicken.

Food	Cooking Time	Temp.
French Fries	6-9 minutes	375°F
Fish Fillets	3-5 minutes	320°F
Chicken Fingers	6-8 minutes	350°F
Chicken Pieces	13-20 minutes	350°F
Fried Zucchini	3 minutes	320°F
Fried Mushrooms	3 minutes	320°F
Onion Rings	3 minutes	320°F
Donuts	3-5 minutes	350°F
Apple Beignets	4 minutes	350°F
Shrimp	4-6 minutes	320°F

### To Store or Reuse Cooking Oil

- Make sure the Deep Fryer is unplugged and the oil has cooled (approximately 2 hours) before attempting to clean or store the Deep Fryer.
- The oil does not need to be changed after each use. We do not recommend storing and reusing oil that was used for frying high protein foods such as poultry, fish or other meats. When oil is mainly used to fry potatoes and is filtered after each use, it can be used 8 to 10 times. However, do not use the same oil for longer than 6 months.
- To filter the oil, first make sure the oil has cooled and then empty the oil from the Oil Container into a storage container or bottle. (Fig. 6) Wash and dry the Oil Container and basket. To reuse, refill the Oil Container with the oil, pouring the oil through a wire strainer or paper filter. (Fig. 7)



Fig. 6 Storing used oil



Fig. 7 Filtering used oil

7

### Detachable Power Cord

Your Deep Fryer has been specifically designed with your safety in mind. This deep fryer has a unique detachable power supply cord. This power supply cord is designed to "Break Away" from the fryer body in the event that the supply cord is inadvertently pulled. This is intended to prevent the tipping of the appliance and hazardous spillage of hot oil.

The female receptacle portion of the power supply cord is permanently attached to the rear of the the control panel.

To connect the male power cord plug to the female receptacle on the appliance, orient the male plug so that it mates with the female receptacle. The male plug can only be inserted one way. If the male plug will not go into the receptacle on the appliance, rotate the male plug 180°.

**IMPORTANT:** Should the male plug become detached from the appliance during use, it is important to:

1. Unplug the power cord from the wall outlet.
2. Turn off the appliance at the control panel.
3. Re-attach the power cord to the appliance.
4. Re-connect to power outlet.
5. Turn the appliance back on.



### How To Reset the Deep Fryer

If for some reason the deep fryer stops heating, the reason might be that the safety reset switch has disconnected. To reconnect the deep fryer, follow the instructions below:

- Allow the deep fryer to cool completely.
- Remove the control panel from the unit.
- Push the thermostat reset button located on the back of the control panel with the back of a ball point pen. (Fig. 8) The unit will beep to indicate that it has re-set.

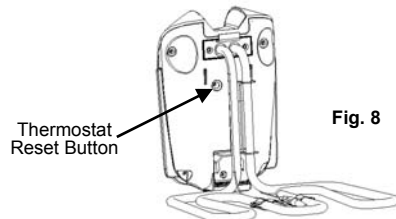

Fig. 8

Thermostat Reset Button

## OPERATING INSTRUCTIONS

### Filling the Oil Container

Never plug in the Deep Fryer before filling with oil to specified level. Always make sure control panel is securely in place in the body and the heating element is inside the oil in the container before plugging in.

- Use blended vegetable oil, pure corn oil or canola oil. Do not use olive oil, margarine, lard or drippings.
- The oil level must always be maintained between the minimum (10 cups/2.4 L.) and the maximum (12.5 cups/3.0 L.) levels marked inside the oil container. Check the oil level before each use. For best results, keep the oil close to the maximum level. (Fig. 3)
- Never mix different oils and fats together. Do not mix old and new oil.

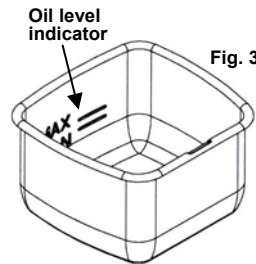

Fig. 3

### Using Solid Fat

**Warning:** Do **Not** put solid shortening in the oil container or the frying basket.

- If using solid vegetable shortening, melt it first in a separate pan and then very carefully pour the melted fat into the oil container.
- Previously used solid vegetable shortening which has curdled and hardened in the oil container should be removed from the oil container and melted in a separate pan before reusing.

### Installing the "Control Panel With the Heating Element" Into Place

- Hold the control panel with the heating element in your hand.
- Slide the control panel down making sure that the control panel is fully seated into the power junction module. (Fig. 4)

**Important Notice:** The Automatic Safety Switch ensures that the unit will not operate unless the Control Panel has been seated properly into the power junction module. This is not a defect. This product is fitted with a safety switch to prevent the unit from turning on accidentally.

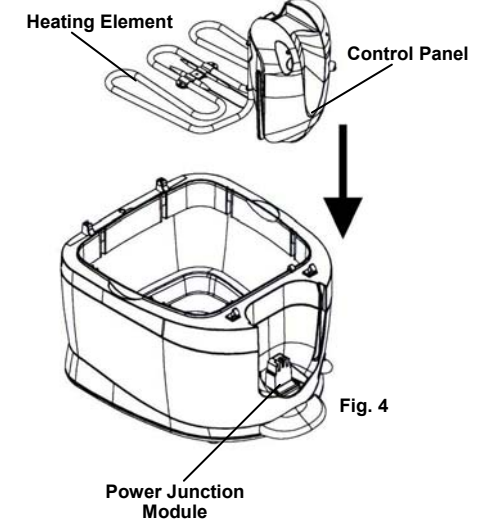

Fig. 4

4

## Using Your Deep Fryer

**CAUTION: Never turn on the fryer when the oil pan is empty. Always ensure the fryer is out of the reach of children. Always use fryer on a flat, heat resistant surface.**

1. Place oil container inside base of unit.
2. Slide control panel with heating elements downward until it connects with the power junction module on the outside of the fryer.
3. Make sure fryer on/off switch is in "off" position.
4. Attach the detachable power cord. When attaching cord - you will feel a magnetic pull on the cord when attaching cord correctly. (Fig. 5)



Fig. 5

5. Pour cooking oil into oil container. Do not exceed max level for cooking oil. (See instructions on filling the oil container on page 4.)
6. Turn On / Off switch to "On" position. The power "On" light will come on.
7. Set the temperature control to the desired temperature and close the cover for the oil to pre-heat.
8. When cooking oil reaches desired setting, the temperature ready light will turn on.

**Note:** The temperature ready light will cycle off and on during the frying cycle as the unit maintains the selected temperature.

## Filling the Frying Basket

When frying frozen foods such as French Fries, remove the frying basket from the deep fryer before filling with frozen food because oil will spatter and may cause burns. You should not fill the frying basket more than halfway. Clean off any ice from frozen food prior to frying. Failure to do so may cause fryer to overflow when food is placed in oil.

- Do not fill the frying basket when it is immersed in oil.
- For optimum results and shorter frying time, basket should be only 1/2 full.
- The basket has approximately 1.5 lb. food capacity. It will hold 4-5 average size pieces of chicken.

## Frying Food

- Always use the frying basket to fry food.
- Always close the lid cover during frying.
- When the oil is pre-heated, the ready indicator light will come on, indicating that the desired temperature is reached.
- Slowly lower the frying basket into the hot oil. Lowering the frying basket too quickly can result in the oil overflowing and splashing.
- Replace the lid carefully.
- It is normal for steam to escape through the sides of the lid while frying.
- Avoid standing too close to the deep fryer while it is working.

**Warning:** When opening the lid cover after frying, lift up the lid slightly, then wait to allow steam to escape before opening the lid completely. Keep face away from unit to avoid burns caused by escaping steam.

1. When the oil in the deep fryer has reached the set temperature, open the cover, place the frying basket onto the oil draining hook, put food into the frying basket and carefully lower the frying basket into the hot oil. Close the cover. If you wish, you can set the 60-minute timer to the desired cooking time. To set the 60-minute timer, turn the knob clockwise to the desired time.
2. Cook food according to the suggested recommended cooking chart or until desired doneness. It is normal for steam to escape through the sides of the cover while frying.

3. If you have pre-set a time for the deep fryer, you will hear a ring when the cooking time has elapsed.

**NOTE:** If you are using the 60-minute timer when you are frying food, please note that the heating element will **NOT** turn off when the timer is up.

4. When cooking is complete, open the cover carefully to avoid burns caused by escaping steam. Lift the frying basket and hook it onto the oil draining hook to allow the food to drain.
5. Remove the food from the frying basket by:
  - Lifting the frying basket by its handle and **CAREFULLY** pouring food onto a plate covered with paper towels or into desired serving utensil.
  - Using tongs to grasp the food from the frying basket and placing into serving utensil.
6. Repeat procedure for remaining food to be cooked.

**NOTE:** Always replace or remove the Frying basket carefully when cooking. **Oil is very hot and can cause severe injury.**

## Using the Auto-Lift Frying Basket

Your deep fryer is equipped with an auto-lift frying basket.

To raise the auto-lift frying basket:

- Depress the handle lock button to unlock the basket handle, lift the basket up and remove from deep fryer before placing food to be fried into the fryer basket.
- Depress the handle lock button that is on the handle of the frying basket to unlock the handle and the frying basket will lower into the oil.
- Once the food has finished frying, lift up the lid cover slowly and wait to allow the steam to escape before opening the lid cover completely.
- Depress the handle lock button once more to unlock the handle and then lift the frying basket out of the oil.
- Let the fried food drain for a few seconds and then remove the basket from the deep fryer.

## Frying Tips

- Do not mix different oils or new and old oil together.
- Replace oil regularly. In general, oil will be tainted fast when frying food containing a lot of protein, (such as poultry, meat and fish). When oil is used mainly to fry potatoes and is filtered after each use, it can be used up to 8 to 10 times, but do not use the same oil for more than 6 months.
- Always replace all oil as soon as it starts foaming when heated, when color becomes dark, when it has a rancid smell or taste or becomes syrupy.
- Make sure that the food to be fried is dry.
- Remove loose ice from frozen food before frying.
- To cook evenly, pieces should be the same size and thickness.
- Thicker pieces will take longer to cook.

## Cleaning Instructions

**Warning:** Always press the "On/Off" switch to the "Off" position to stop the heating element from heating and remove the plug from the wall socket before cleaning. Allow the Deep Fryer and the oil to cool completely (approximately 2 hours) before cleaning. Never immerse the Control Panel, cord, plug or main enclosure in water or any other liquid.

- Follow the cleaning instructions on page 3. (Before Using for the First Time)
- Never immerse the control panel, cord or plug in water or any other liquid.
- Do not place the control panel, cord or plug in the dishwasher.
- Clean the control panel only with a damp cloth.
- The oil container, frying basket, and cover can be washed in the dishwasher. To remove the cover, open it and pull straight up. To replace the cover onto the unit after cleaning, insert the spring tang into the spring tang slot in the back of the main unit.
- Wipe the body of the deep fryer and the control panel with a damp cloth. **Do not** put the body of the deep fryer and the control panel in the dishwasher.