



- Unprecedented high level of efficiency.
- Quick oil temperature recovery.
- Stainless steel front, sides and tank.
- Dual, solid-state controls.
- Melt cycle for solid or liquid shortening.
- 7-year limited fry tank warranty.

*Shown with optional automatic basket lifts*

The Alto-Shaam ASF-60E open electric fryer cabinet is constructed of stainless steel and includes front- and rear-mounted, heavy duty leveling casters. The fryer is provided with low-watt density, ribbon-style heating elements. The 14 gauge stainless steel fry tank holds 62 pounds (28 kg) of frying compound. Also included are two fry baskets and a cleaning brush set. Fryer has a temperature range of 200°F to 390°F (93°C to 199°C). Solid state control provides a temperature accuracy within 4° of set point.

**ASF-60E Open Electric Fryer with Basic Control**

---



**FACTORY INSTALLED OPTIONS**

- Automatic Basket Lifts
- Deluxe Control
  - Programmable memory for up to six (6) product menu keys per lift.
- Fryer/Dump Station Battery
  - Create a battery of ASF-60E fryers and ASF-60W dump stations in any combination of up to five (5).
  - Includes oil filtration system. Specify right- or left-side placement when ordering.

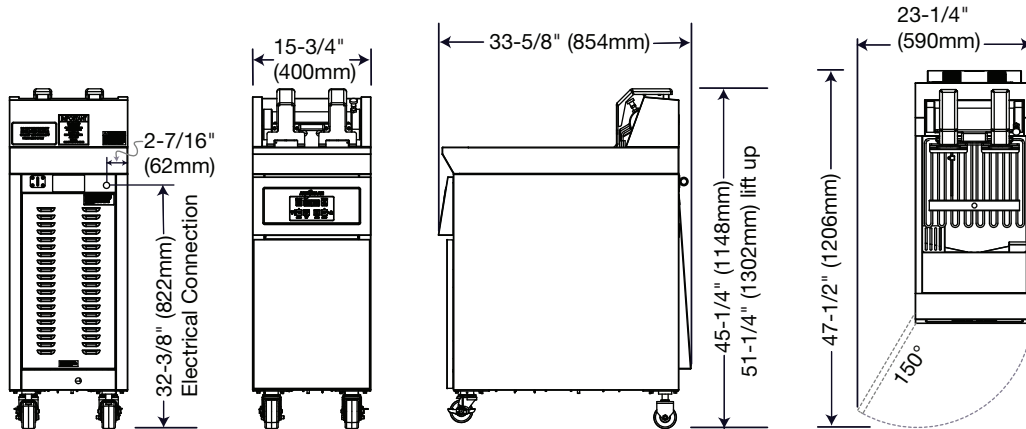

<b>DIMENSIONS EXTERIOR H x W x D:</b>
45-1/8" x 15-3/4" x 33-5/8" (1146mm x 400mm x 854mm)
<b>BASKET DIMENSIONS (H x W x D)</b>
5-7/8" x 5-3/16" x 13-13/16" (149mm x 131mm x 351mm)

<b>CAPACITY</b>
SHORTENING/OIL: 62 lb (28 kg) MAXIMUM

<b>ELECTRICAL</b>				
VOLTAGE	PHASE	CYCLE/HZ	AMPS	kW
208-220 (ETL)	3	60	47	17.93
at 208	3	60	45	16.2
at 220	3	60	47.6	18.2
240 (ETL)	3	60	43.1	17.93
380-415				
at 380	3	50	20.4	15.4
at 415	3	50	25.4	18.3
440-480 (ETL)				
at 440	3	60	40.8	31
at 480	3	60	44.4	37
<b>No cord and plug</b>				

<b>WEIGHT EST</b>	<b>NET WEIGHT</b>	<b>SHIP WEIGHT</b>
	248 lb (113 kg)	330 lb (150 kg)
<b>CARTON DIMENSIONS:</b>	39" x 22" x 55" (991mm x 559mm x 1397mm)	

<b>INSTALLATION REQUIREMENTS</b>
Hood installation is required.
Fryer must be installed level.
A flexible connector must be installed and secured to the building structure. NOT FACTORY SUPPLIED

<b>CLEARANCE REQUIREMENTS</b>
BACK: 6" (152mm) FRONT: 25" (635mm)
6" (152mm) REQUIRED ON ALL SIDES WHEN ADJACENT TO COMBUSTIBLE SURFACES.

<b>STANDARD ACCESSORIES</b>	
<input type="checkbox"/> Basket, Half-Size (2 INCLUDED AS STANDARD)	BS-27963
Brush Set (ONE 3-BRUSH SET INCLUDED AS STANDARD)	
<input type="checkbox"/> ANGLE BRUSH	BH-27382
<input type="checkbox"/> SCRUB BRUSH	CE-27122
<input type="checkbox"/> STRAIGHT BRUSH	BH-27121
<b>OPTIONS</b>	
<input type="checkbox"/> Fry Pot Cover	5007596
<input type="checkbox"/> Strainer/Skimmer	CE-27400