

# WARING PRO<sup>®</sup>

## PROFESSIONAL DEEP FRYER

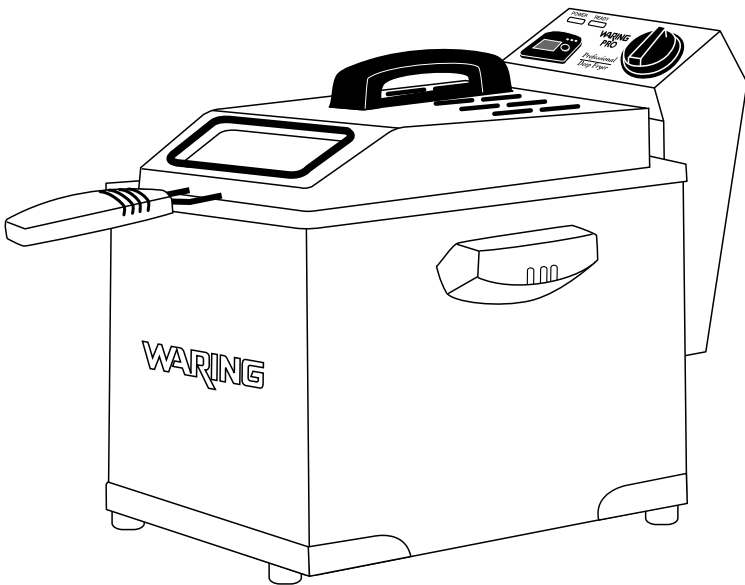

DF175

For your safety and continued enjoyment of this product,  
always read the instruction book carefully before using.

# IMPORTANT SAFEGUARDS

When using electrical appliances, basic safety precautions should always be followed, including the following:

1. **READ ALL INSTRUCTIONS.**
2. **Unplug from outlet when not in use and before cleaning. Allow to cool before putting on or taking off parts, and before cleaning the appliance. Extreme caution must be used when moving an appliance containing hot oil or other liquids.**
3. Do not touch hot surfaces. Use handles and knobs.
4. To protect against electric shock, do not immerse control panel, cord, plug or deep fryer in water or other liquids.
5. This appliance is not for use by children. Close supervision is necessary when any appliance is used near children.
6. Never leave appliance unattended when it is connected to the power outlet.
7. Always attach breakaway cord to appliance first, then plug into wall outlet. To disconnect, turn the switch to Standby, then remove plug from wall outlet.
8. Do not operate any appliance with a damaged cord or plug, or after the appliance malfunctions or has been damaged in any manner. Return appliance to the nearest authorized service center for examination, repair or adjustment.
9. The use of attachments not recommended or sold by the manufacturer may result in fire, electric shock or injury.
10. Do not use outdoors.
11. Do not let cord hang over edge of table or counter, or touch hot surfaces.
12. Do not place on or near a hot gas or electric burner, or in a heated oven.
13. Do not operate under cabinets.
14. The appliance will automatically shut off if operation exceeds 12 minutes without oil. If this occurs, resetting of the appliance is required.
15. If appliance still does not function after following reset instructions, please contact a Waring Certified Customer Service Center for assistance.
17. Be sure handles are properly attached to basket and locked in

place. See detailed assembly instructions.

18. Do not use this appliance for other than intended use.
19. Periodically check for looseness of screws or nuts and retighten them. CAUTION: Overtightening can result in stripping of screws or nuts or cracking of handle or feet.
20. Do not exceed 60 minutes ON time within a period of 2 hours.

# SAVE THESE INSTRUCTIONS FOR HOUSEHOLD USE ONLY

## IMPORTANT SAFETY TIPS

1. Always keep lid closed while deep fryer is cooking food. Use basket handle to raise and lower basket. After removing lid, always raise basket out of hot oil, rest on basket hook and allow food to drain for 10 to 20 seconds.
2. **BEWARE OF STEAM WHEN OPENING LID.**
3. Wet food should be dried first with paper towels. Remove loose ice from frozen foods. Close the lid when frying. Beware of oil splattering when food is put into the oil.
4. Keep appliance at least 4 inches away from walls or other objects during operation. Do not place any objects on top of appliance while it is operating.
5. Be sure oil container is filled to at least the minimum oil level. Do not fill above the maximum. Do not operate appliance without oil or with an insufficient amount of oil. Never pour oil into heated oil container.
6. Do not operate this appliance if the lid and the oil container are not completely dry.
7. Keep this fryer out of reach of children while in use and away from edges of countertops, where it could be pulled off or pushed over by children.
8. Do not use any solid/hydrogenated oil, shortening or lard in this deep fryer.

**CAUTION:** To prevent damage to countertop or tabletop finish, use a nonflammable, heat-resistant coaster or placemat between the appliance and the countertop or tabletop surface. Never place on carpet, furniture, or other combustible materials.

## PARTS

- |   |                                 |
|---|---------------------------------|
| 1. Lid  | 7. Brushed Stainless Steel Body |
| 2. Basket with Collapsible Handle                 | 8. Reset Button                 |
| 3. Heating Element                                | 9. Control Knob                 |
| 4. Power ON Indicator Light                       | 10. Digital Timer               |
| 5. Oil Ready Indicator Light                      |                                 |
| 6. Enamel-Coated Oil Container with Pouring Spout |                                 |

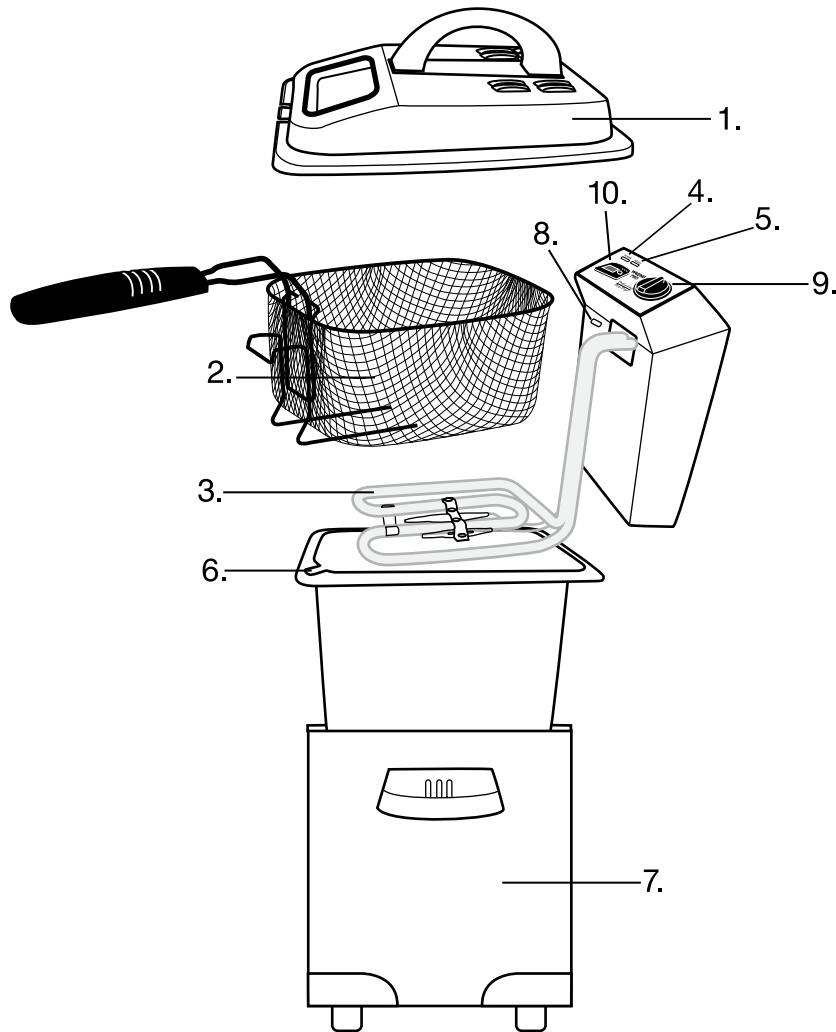

## Breakaway Cord and Polarized Plug

This appliance features a breakaway cord and polarized plug (one blade is wider than the other).

The breakaway cord is designed to quickly disconnect from the appliance when a pulling force is applied.

NOTE: The breakaway cord can fit into the appliance in only one direction. Please refer to printing on the cord connector that states “this side up.” To reduce the risk of electric shock, a polarized plug is featured. This plug is intended to fit only into a polarized outlet. If the plug does not fit into the outlet, reverse the plug. If it still does not fit, contact a qualified electrician. Do not attempt to modify the plug in any manner.

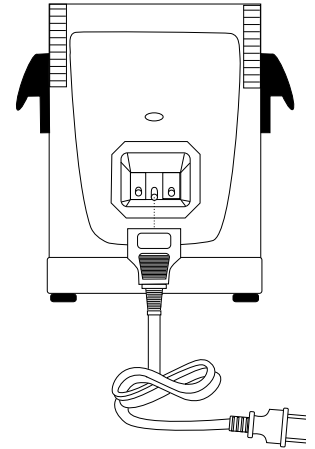

## SHORT CORD INSTRUCTIONS

CAUTION: A short power supply cord is provided to reduce the risk of personal injury resulting from becoming entangled in or tripping over a long cord.

## EXTENSION CORD USE

An extension cord or longer detachable cord is not recommended for use with deep-fat fryers.

## ELECTRIC POWER

If the electrical circuit is overloaded with other appliances, your appliance may not operate. It should be operated on an electrical circuit that is free from other appliances. If you are not sure of the reason for overloading or cannot find a separate circuit, contact a qualified electrician.

## HOW TO USE YOUR WARING PRO® PROFESSIONAL DEEP FRYER

1. **This appliance is designed for household use only. It is not intended for commercial use.**
2. Before you use the Waring Pro® Professional Deep Fryer for the first time, remove all packaging materials and follow cleaning instructions in this book.
3. Lift off lid covering oil container.
4. Remove basket from oil container. Attach handle to basket by squeezing posts and assembling as in diagram.
5. Pour approximately 3.25 liter (3.4 quart) of good quality vegetable, corn, canola, soybean, or peanut oil into reservoir until it reaches a level between the MIN and MAX marks inside the container. **DO NOT OVER- OR UNDER-FILL.**

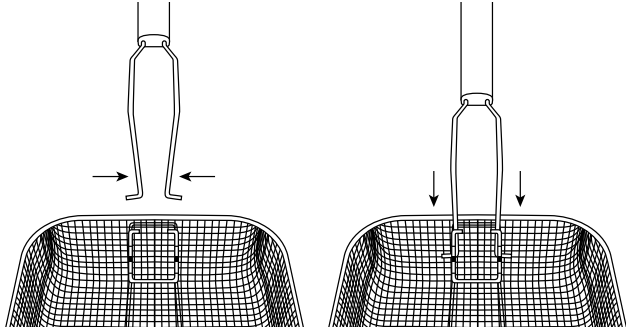

6. Put lid on deep fryer. Make sure the switch is on Standby.
7. Attach breakaway cord to the back of the appliance, then plug into outlet.
8. When unit is plugged in, power light will turn on.
9. Set the temperature control knob to the desired temperature. The oil Ready light will turn green once the oil has reached the desired temperature.
10. Remove lid and put food into basket. Lower basket into oil and replace lid.  
**CAUTION: Oil is hot. Please use caution when placing food into hot oil.**
11. To set timer, press until desired frying time appears. Time will flash twice and then go solid to start countdown process. Timer will count down in minutes. The timer will countdown in seconds for the last minute. When the time is reached, the fryer

will beep several times and show 00 in the display. To cancel, press button and reprogram timing. Maximum frying time is 60 minutes.

**CAUTION: The timer will not turn off when the programmed time is completed.**

12. When recommended frying time has elapsed, raise the basket to see if the food has reached the required golden color. If the food is done, carefully lift and hang basket on edge of the oil reservoir. Allow oil to drain 10 to 20 seconds. Remove basket, and place cooked food onto absorbent paper towels.  
**NOTE: To preserve oil quality, do not add salt or spices to the food until after it has been removed from the fryer.**
13. When cooking is finished, turn temperature control to Standby. Unplug the breakaway cord from the wall outlet before detaching from the appliance.

## CHANGING THE TIMER BATTERY

1. Insert flat head screw driver or similar object into opening of left side of timer (located on the control panel) and push up to release the timer housing.
2. Once timer housing has been removed, turn upside down and remove battery cover. Replace with a L1154 button cell battery.
3. Place timer housing back into control panel.

## CLEANING & MAINTENANCE INSTRUCTIONS

1. Always unplug appliance, detach the breakaway cord and let the oil cool down to room temperature before cleaning.
2. Remove lid.
3. Lift out basket.
4. The control panel should never be immersed in water or other liquids. Clean the outer surface of the heating element with a damp cloth containing mild soap solution or plain water.
5. Once oil has cooled, detach the container from the stainless steel body and use the spout on the corner to pour oil into a suitable container.
6. The frying basket should be hand washed before first use and should be seasoned with oil before going into the dishwasher for the first time. Lid, oil container and frying basket are dishwasher safe. Dry parts thoroughly after cleaning.

7. The stainless steel body is submersible and should be washed by hand with warm soapy water.
  8. Ensure that both the lid and the oil container are completely dry after washing and before use.
  9. After cleaning, reassemble oil container, heating element, basket and lid onto deep fryer. The heating element must be seated properly or appliance will not operate.
  10. **Warning: When cleaning, use care – under-edge of deep fryer is sharp.**
  11. For storage, basket handle can be folded down to fit inside container.
  12. Tip: For ease in cleaning, wipe control panel with damp microfiber cloth. Microfiber cloths are available in most kitchenware stores.
- NOTE: Oil staining on the heating element and oil container can be easily cleaned with a plastic scrubbing pad.**
13. NEVER PUT THE CONTROL PANEL IN WATER OR OTHER LIQUID TO CLEAN. Wipe it with a damp cloth or sponge. Do not use abrasive cleansers, which could scratch the surface.
  14. **NOTE:** Any other servicing should be performed by an authorized service representative.

## SAFETY FEATURES

The Waring Pro® Professional Deep Fryer is equipped with the following features to ensure safety:

- Safety Interlock – The control panel/heating element must be properly seated or deep fryer will not operate.
- Breakaway Cord – The cord is designed to quickly disconnect from the appliance when a pulling force is applied.
- Thermostat Overload Protection – Your Waring Pro® Professional Deep Fryer is equipped with thermostat overload protection. If the unit heats up beyond the recommended temperature level, the deep fryer will automatically turn off. To reset, unplug the unit from the wall outlet and allow it to cool down.

Remove the control panel and heating element from the unit.

**CAUTION:** Heating element is extremely hot. Allow it to cool thoroughly before removing it. You will find a reset button on the front of the control panel below the controls. Using a toothpick or another long, thin object, push the reset button and replace the control panel.

**NOTE:** The unit will not work if the control panel is not properly mounted. Plug the unit back in, turn on and continue use. If the unit still does not operate, repeat the steps above or call a Waring Certified Customer Service Center for assistance.

## HINTS

- When cooking foods dipped in fresh batter, first lower basket. Using tongs, add food directly to oil. Use basket to lift out food when finished cooking.
- Sort or cut food into pieces of uniform size. All the food will then be cooked in the same amount of time. To reduce splattering, remove excess moisture or ice from food.
- Store oil in oil container for a limited time. When oil has cooled to room temperature, pour into a suitable container with lid and refrigerate.
- The oil does not need to be changed after each use. In general, the oil will be tainted rather quickly when frying food containing a lot of protein (such as poultry, meat or fish). When oil is mainly used to fry potatoes and it is filtered after each use, it can be used 8 to 10 times. However, do not use the oil for longer than 6 months.
- It is important to follow the temperature recommendation for every recipe. If the temperature is too low, the fried food absorbs oil. If the temperature is too high, a crust quickly forms on the outside while the inside remains uncooked.
- For best results, drop freshly sliced food into basket one piece at a time.

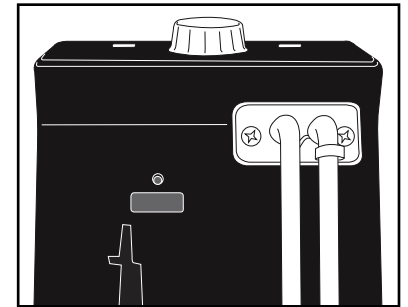

## FRYING FROZEN FOODS

- Due to their extremely low temperature, frozen foods inevitably lower the temperature of the oil. For best results, do not overload the basket with frozen foods.
- Follow the instructions on the frozen food package for cooking time and temperature.
- Frozen foods are frequently covered with a coating of ice crystals, which should be removed before frying. Lower the basket very slowly into the oil in order to ensure that oil does not boil over.

## FILTERING AND CHANGING THE OIL

- Make sure the Waring Pro® Professional Deep Fryer is unplugged and the oil has cooled before cleaning or storing.
- The oil does not need to be changed after each use. In general, the oil will be tainted rather quickly when frying food containing a lot of protein (such as poultry, meat or fish). When oil is mainly used to fry potatoes and it is filtered after each use, it can be used 8 to 10 times. However, do not use the oil for longer than 6 months.
- **WARNING:** Always remove the plug from wall socket before cleaning. Allow the Waring Pro® Professional Deep Fryer and the oil to cool completely (approximately 2 hours) before cleaning. Never immerse the control panel, cord or plug in water or any other liquid.

## RECIPES

### Tips for Frying Breads

Heat oil to 375°F unless recipe specifies otherwise. A cube of bread should brown in approximately 60 seconds. Correct temperature is extremely important. If the temperature is too high, breads will brown before the insides have cooked; if it is too low, the bread will absorb the fat and become soggy and greasy.

Cook only as much bread as will float easily in the oil. Too much added to the Waring Pro® Professional Deep Fryer will cause the temperature to drop, and the pieces will be difficult to turn. Turn bread when it rises to the top of the oil, taking care not to pierce it. Lift cooked breads from the fryer; allow them to drain for a moment, then place on paper towels to drain.

## Applesauce Spice Doughnuts

Makes about 16 doughnuts

2½	cups unbleached, all-purpose flour, divided
2	teaspoons baking powder
¼	teaspoon salt
½	teaspoon cinnamon
⅛	teaspoon ground allspice
	pinch freshly grated/ground nutmeg
½	cup granulated sugar
1	tablespoon plus 1 teaspoon vegetable shortening
⅔	cup applesauce
1	large egg
	vegetable oil for frying
	flour for dusting
	powdered or granulated sugar for dusting

Using a whisk, blend together the flour, baking powder, salt, and spices in a medium bowl; reserve. Put the sugar and shortening in a large bowl. With an electric mixer on low speed, beat to blend and break up the shortening. Add the applesauce and egg; beat until smooth. Add the flour mixture in two additions and blend on medium speed until mixed. Cover dough and chill for at least 1 hour. Divide dough into two equal portions. Place one portion of dough on a generously floured surface and dust with flour. Roll out to ½-inch thickness. Cut dough with a floured doughnut cutter and place doughnuts on a waxed paper-lined baking sheet or tray. Repeat with remaining dough. Re-roll scraps and repeat.

Heat vegetable oil in Waring Pro® Professional Deep Fryer until it reaches 375°F. Carefully lower 3 doughnuts into the hot oil – do not overcrowd! Fry on each side, about 1½ to 2 minutes, turning with a slotted spoon or wire skimmer. Remove and drain on layered paper towels. Pat gently to remove any excess oil and sprinkle with desired amount of sugar.

## Hush Puppies

Makes about 12 to 20 pieces

- oil for frying
- 1 cup cornmeal
- ¼ teaspoon salt
- ⅛ teaspoon baking soda
- 2 tablespoons finely chopped white or green onion
- 2 tablespoons plus 2 teaspoons buttermilk
- 3 tablespoons plus 2 teaspoons water

Heat oil in the Waring Pro® Professional Deep Fryer until it reaches 375°F. While the oil is heating, make the Hush Puppy batter. Combine cornmeal, salt and baking soda in a medium bowl. Stir in onion. Add buttermilk and water – stir just to moisten the dry ingredients. Form into rounded tablespoonfuls, drop carefully into the hot oil and fry until golden brown, turning once with a slotted spoon or wire skimmer. Remove from the oil. Drain on layers of paper towels. Serve immediately.

## Spicy Buffalo Wings

Makes 16 pieces

- 8 chicken wings
- ⅓ cup unsalted butter, melted
- 3 to 6 tablespoons “Louisiana-style” hot sauce (such as Frank’s Louisiana Red Hot!™)
- 2 teaspoons cider vinegar
- oil for frying
- blue cheese dressing and celery sticks, carrot sticks, zucchini sticks

Cut wing tips from wings and discard or reserve for making chicken stock. Split each wing at the joint and cut through so there are 2 pieces from each wing. Rinse and dry completely. In a large bowl, combine the melted butter, hot sauce and cider vinegar and stir until completely blended. Heat oil until it is 375°F. Put half the wings into the Waring Pro® Professional Deep Fryer and cook until browned and crispy, about 12 to 15 minutes. Remove wings; drain briefly on layered paper towels. Then stir hot, crispy wings into the hot sauce mixture. Repeat with remaining wings. Serve hot with cold vegetable sticks and blue cheese dressing.

Note: If you have some guests who do not appreciate hot and spicy, fry the wings as instructed and toss with your favorite BBQ sauce or honey mustard sauce. For “suicidal” strength wings, add Tabasco® or other hot sauce along with the Louisiana-style hot sauce.

## Blue Cheese Dressing

- ½ cup mayonnaise (regular or lowfat)
- ½ cup sour cream (regular or lowfat)
- ½ cup crumbled blue cheese
- 1 teaspoon finely chopped garlic
- ¼ cup finely chopped parsley
- 1 to 2 tablespoons finely chopped onion
- 1 tablespoon fresh lemon juice

Put all ingredients in a bowl and stir well to blend. Cover and refrigerate for at least 30 minutes before serving to allow flavors to blend.

## Fried Calamari

Makes about 3 servings

- 1½ pounds cleaned calamari, including some tentacles
- vegetable oil for frying
- 1⅓ cups unbleached, all-purpose flour
- 2 teaspoons finely chopped parsley
- ¾ teaspoon granulated garlic
- ¾ teaspoon each: kosher salt and freshly ground pepper
- marinara sauce for dipping
- fresh lemon wedges for garnish

Rinse and drain the calamari; place on thick layers of paper towels, pressing and blotting them completely dry with another layer of paper towels on top. Cut the bodies into ½-inch rings, and cut tentacles into halves or quarters if large. Heat oil to 360°F in the Waring Pro® Professional Deep Fryer. Preheat the oven to 500°F. Line two cookie sheets with a triple thickness of paper towels. Put the flour, parsley, granulated garlic, salt, and pepper into a jumbo resealable food storage bag. Working with about a quarter of the calamari at a time, drop calamari into the bag, seal and shake. Squeeze the sides of the bag to completely coat the calamari. Take care that the pieces are individually coated and not stuck together. Remove from the bag and place on a baking sheet lined with plastic wrap. Repeat until all the calamari have been coated evenly with flour mixture.

Gently add calamari to hot oil, about 1 to 1½ cups at a time, trying to let all the pieces drop in separately. Do not crowd the calamari, because crowding will drop the temperature of the oil. The calamari will be pale golden and just cooked in about 40 to 60 seconds. Do not overcook – they will become tough. Lift the calamari out, using a slotted spoon or metal skimmer, and drain in a single layer on prepared cookie sheets. Repeat with the remaining calamari. When all the calamari have been fried, reheat them in the 500°F oven for several minutes. Sprinkle lightly with a little more salt, and serve with warm marinara sauce for dipping.

## Herbed Beer Batter Onion Rings

Makes 2 to 4 servings

- ¾ cup plus 2 tablespoons lager or ale
- 1 cup unbleached, all-purpose flour
- ½ cup chopped fresh parsley
- 1 tablespoon chopped fresh thyme
- 1 teaspoon finely chopped fresh garlic
- ¾ teaspoon kosher salt
- 1 to 2 onions (about 1 pound total)
- flour for dusting
- vegetable oil for frying
- kosher salt for sprinkling

In a medium bowl, whisk the beer into the flour until smooth. Stir in the parsley, thyme, and garlic. Let batter stand 30 minutes. Stir in salt. Cut onion crosswise into ½-inch thick slices. Remove and discard skin, stem and root ends. Separate slices into rings. Toss lightly with flour. Heat the vegetable oil in the Waring Pro® Professional Deep Fryer until it reaches 375°F. Working with about 4 or 5 rings at a time, dip each ring into batter, and allow excess to drip off. Carefully lower coated onion rings into deep fryer, one at a time. Fry until golden, turning as needed, about 1 to 2 minutes. Lift out with tongs and place on layered paper towels to drain. Sprinkle with kosher salt while hot, and serve.



## Better than Fast Food French Fries

Makes about 6 servings

- peanut or vegetable oil for frying
- 2 russet potatoes
- kosher salt and freshly ground pepper to taste

Heat the oil in the Waring Pro® Professional Deep Fryer to 325°F. Cut potatoes into french fry-cut uniform sticks (about 6 x 6 mm) or into slices ¼ inch or less thick. As you cut, put the potatoes in a bowl of ice water to keep them from turning brown.

Drain and dry the potato strips completely and thoroughly. They cannot be at all wet, or the oil will spatter and spit. Fry the potatoes in small batches. Cook for about 3 minutes, remove and drain on layers of paper towels. Increase temperature of oil to 375°F. In small batches again, fry the potatoes for a second time, this time about 4 minutes, until golden and crispy. Drain on fresh layers of paper towels. Season to taste and serve immediately. Seasoning suggestions: herb blends, Cajun or Creole seasonings, and chili powder.

## Crispy Chicken Fingers with Honey Mustard Sauce

Makes 6 servings

- 3 tablespoons kosher salt
- 3 tablespoons brown sugar
- 1 cup boiling water
- 12 ice cubes
- 4 skinless, boneless chicken breast halves
- 1 cup unbleached, all-purpose flour
- ½ teaspoon kosher salt
- ¼ teaspoon freshly ground pepper
- ¼ teaspoon paprika
- ¼ teaspoon granulated garlic powder
- oil for frying
- ¾ cup buttermilk or regular milk

### Honey Mustard Sauce

- ½ cup honey
- ¼ cup Dijon mustard (regular or grainy)

Combine salt, sugar and boiling water in a medium-large heat-proof bowl. Stir until sugar and salt are completely dissolved. Add ice. Cut chicken into ½ x 2-inch strips. Place cut chicken in the chilled brine mixture and refrigerate for 30 to 60 minutes. Combine the flour with the salt, pepper, paprika, and granulated garlic in a shallow bowl. Blend honey and mustard to make honey mustard sauce. When ready to cook, drain chicken and pat completely dry. Heat the oil in the Waring Pro® Professional Deep Fryer to 350°F. Dip the drained and dried chicken strips in buttermilk and roll in flour to coat well. Place the strips on a plate. Carefully place the chicken strips in the hot oil in batches. Cook, turning once, about 3 to 4 minutes per side. Drain on layers of paper towels and serve with honey mustard sauce.

### DEEP FRYING GUIDE – Fresh or Uncooked Foods

Fresh indicates food prepared from a recipe or purchased fresh, not frozen. Read package label to determine if prepared, packaged foods are NOT precooked. If frozen, do not thaw; place foods directly from package into preheated oil. If there are ice granules around prepared foods, set pieces on a paper towel and pat dry. Moist vegetables will cause the oil to splatter.

Frying times may vary because of food temperature, quantity and size of pieces. Best results are obtained when food is cooked in small batches and size of pieces is uniform. Check deep-fried foods at the shortest times given; deep fry until heated through.

#### Low Heat 325°F

Turkey thighs, bone-in, skin-on . . . . .	20–22 min.
Turkey breast, bone up, skin down . . . . .	30–35 min.
Breaded eggplant . . . . .	5–6 min.
Breaded portobello mushrooms . . . . .	4½–5 min.

#### Medium Heat 350°F

Frozen chicken nuggets . . . . .	5½–6 min.
Breaded chicken tenders . . . . .	3½–4½ min.
Breaded, boneless chicken breasts . . . . .	5½–6 min.
Breaded bone-in pork chops . . . . .	7½–8 min.
Egg rolls . . . . .	5 min.
Chimichangas . . . . .	7–7½ min.
Large shrimp . . . . .	1–2 min.

#### High Heat 375°F

Red potato chips . . . . .	2–3 min.
Yam potato chips . . . . .	2–2½ min.
American fries . . . . .	5–6 min.
Thin french fries . . . . .	3–3½ min.
Thick french fries . . . . .	3½–4 min.
Curly french fries . . . . .	4½–5 min.
Egg rolls . . . . .	6½–7 min.

### DEEP FRYING GUIDE – Prepared Foods

Prepared foods listed in this chart are breaded and cooked prior to packaging. If frozen, do not thaw; place foods directly from package into preheated oil. If there are frozen ice granules around prepared foods, set pieces on a paper towel and pat dry.

Use this chart as a guide to deep frying times. Best results are obtained when food is cooked in small batches and size of pieces is uniform. Check deep fried foods at the shortest times given; deep fry until heated through.

#### Low heat 325°F

Onion rings . . . . .	5–6 min.
-----------------------	----------

#### Medium heat 350°F

Chicken tenders . . . . .	5½–6 min.
Chicken nuggets . . . . .	3–4 min.
Chicken pieces . . . . .	7–8 min.
Small mushrooms . . . . .	2½–3 min.
Medium shrimp . . . . .	2–2½ min.
Small shrimp pops . . . . .	1–2 min.

#### High heat 375°F

Large or fantail shrimp . . . . .	1–2 min.
Mozzarella sticks . . . . .	2–3 min.
Halibut fish filets . . . . .	3–3½ min.
Halibut fish balls . . . . .	2–3 min.

Trademarks or service marks of third parties referred to herein are the trademarks or service marks of their respective owners.

©2011 Waring Consumer Products  
150 Milford Road  
East Windsor, NJ 08520  
[www.waringpro.com](http://www.waringpro.com)

Printed in China  
DF175 IB  
11WR119913

IB-10587