



2ERD40F SHOWN

6106

### KLEENSCREEN SERIES ELECTRIC FRYER BATTERY

MODEL	ML
ERD40F	126905
ERD50F	126906
ERD225F	126907
ERD85F	126908
ERC40F	126909
ERC50F	126910
ERC225F	126911
ERC85F	126912

This Service Manual Supplement should be used in addition to F24577 "FLOOR MODEL ELECTRIC FRYERS" for Service Information related to the Fryer and F24599 "MOBILE FILTERS" for Service Information related to the pump.

**- NOTICE -**

This Manual is prepared for the use of trained Vulcan Service Technicians and should not be used by those not properly qualified. If you have attended a Vulcan Service School for this product, you may be qualified to perform all the procedures described in this manual.

This manual is not intended to be all encompassing. If you have not attended a Vulcan Service School for this product, you should read, in its entirety, the repair procedure you wish to perform to determine if you have the necessary tools, instruments and skills required to perform the procedure. Procedures for which you do not have the necessary tools, instruments and skills should be performed by a trained Vulcan Service Technician.

Reproduction or other use of this Manual, without the express written consent of Vulcan, is prohibited.

# TABLE OF CONTENTS

GENERAL .....	3
Introduction .....	3
Description .....	3
Model Designations .....	3
Kleenscreen Filtering System .....	4
Information Sources .....	4
Installation .....	4
Operation .....	4
Cleaning .....	4
Maintenance .....	4
Specifications .....	5
Electrical .....	5
REMOVAL AND REPLACEMENT OF PARTS .....	6
Covers and Panels .....	6
Pump and Motor .....	6
Filter Valve and Discard Valve Switches .....	7
Heater Contactors .....	7
SERVICE PROCEDURES AND ADJUSTMENTS .....	8
Computer Control Board Diagnostics .....	8
ELECTRICAL OPERATION .....	9
Sequence of Operation .....	9
Solid State Fryer Control, Full Vat .....	9
Computer Control, Full Vat .....	11
Kleenscreen Filtering System .....	12
Discard of Used Oil .....	13
Component Function .....	14
Component Location .....	15
Schematic Diagrams .....	16
Solid State Control and Kleenscreen Filter, Full Vat .....	16
Computer Control, Full Vat .....	18
Computer Control, Split Vat .....	19
Kleenscreen Filtering System, Computer Control .....	20
Heater Circuit, Solid State Controls, Full Vat .....	21
Heater Circuit, Solid State Controls, Split Vat .....	22
Basket Lift Circuit, Solid State Controls .....	23
Wiring Diagrams .....	24
Kleenscreen Filtering System .....	24
Wiring Diagram Index .....	25
TROUBLESHOOTING .....	50
Solid State Control .....	50
Computer Control .....	51
Computer Control Harness Pin-Outs Chart .....	52
Kleenscreen Filtering System .....	53
CONDENSED SPARE PARTS LIST .....	56

© VULCAN 2001

# GENERAL

## INTRODUCTION

### Description

This Service Manual Supplement covers specific service information only related to the Vulcan Kleenscreen filter models listed on the front cover.

The fryer battery utilizes many of the same controls and components as the Vulcan ERD series (solid state control) and ERC series (computer control) fryers.

Kleenscreen fryer batteries are available in a minimum of two and a maximum of six fryer sections. The fryer size of each section is identical.

An ERO series Frymate (dump station) can also be included as one or more of the sections.

### Model Designations

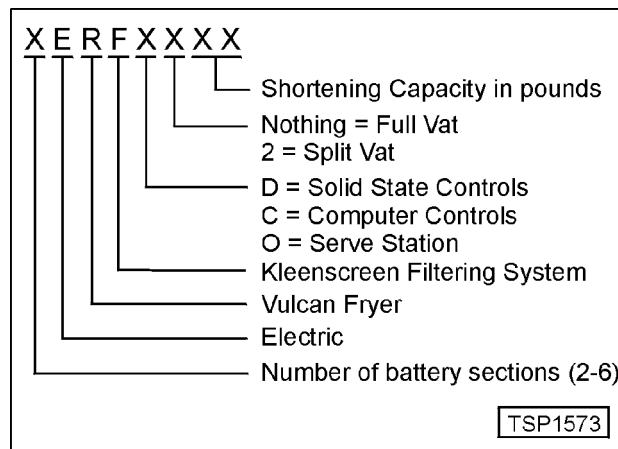

### Models, Features and Options

MODEL	FEATURES				OPTIONS	
	FRYER WIDTH (INCHES)	FRYING COMPOUND PER FRYER (POUNDS)	VAT TYPE	CONTROL TYPE	BASKET LIFTS	
					AUTOMATIC	TIMERS (MIN)
2ERD40F <sup>1</sup>	31	40	Full	Solid State	Single or Dual	7.5 or 15
2ERD50F <sup>1</sup>	31	50	Full	Solid State	Single or Dual	7.5 or 15
2ERD225F <sup>1</sup>	31	50 (25 each vat)	Split	Solid State	Single (each vat)	7.5 or 15
2ERD85F <sup>2</sup>	42	85	Full	Solid State	Single or Dual	7.5 or 15
2ERC40F <sup>1</sup>	31	40	Full	Computer	Single or Dual	7.5 or 15
2ERC50F <sup>1</sup>	31	50	Full	Computer	Single or Dual	7.5 or 15
2ERC225F <sup>1</sup>	31	50 (25 each vat)	Split	Computer	Single (each vat)	7.5 or 15
2ERC85F <sup>2</sup>	42	85	Full	Computer	Single or Dual	7.5 or 15
ER015 (Frymate)	15 1/2					
ER021 (Frymate)	21					
<b>NOTES:</b>	1. For each additional fryer section, add 15 1/2 inches to the width. 2. For each additional fryer section, add 21 inches to the width.					

## Kleenscreen Filtering System

The new "Kleenscreen" filtering system has been integrated into the ER Series fryer battery. The filter is housed in a pull-out drawer assembly at the base of the fryer. The filtering components in the drawer include a stainless steel filter tank, crumb-catch basket and fine mesh screen. With the filter drawer closed, a self-seating return oil line provides the path to return the filtered oil to the fry tank.

This system is designed to provide a thorough and easy method for filtering fryer oil.

Some of the benefits include:

- Self-contained system eliminating the use of external filter equipment.
- Paperless filtering system.
- Easy to clean and low maintenance.

## Information Sources

Refer to the appropriate manual below for related information.

MANUAL	ER SERIES ELECTRIC FRYERS	PUMP INFORMATION	KLEEN SCREEN
Service	F24577	F24599	-
Parts	F31007	-	-
Installation and Operation	F30981	-	-
Filtration System User's Guide	-	-	F31150
F24696	Use the Service information found in this Service Manual Supplement. The Supplement covers additional Service Information specific to the Kleenscreen fryer and filtering system.		

## INSTALLATION

Refer to the Installation and Operation Manual for specific installation instructions.

## OPERATION

Refer to the Installation and Operation Manual for specific operating instructions.

## CLEANING

Refer to the Installation and Operation Manual for specific cleaning instructions.

## MAINTENANCE

Refer to the Installation and Operation Manual for specific maintenance instructions.

**SPECIFICATIONS**

**Electrical**

Separate electrical connections are required for each section of the battery.

- 208VAC, 240VAC or 480VAC (3 phase, 60HZ) to power the heating elements.
- On 208VAC and 240VAC models, step down transformer(s) provide power for the fryer controls, basket lift(s) if installed, and Kleenscreen filtering controls.
- On 480VAC models, a 120VAC connection is required for each fryer section.
- All models require a separate 120VAC connection for the pump motor.

**NOTE:** Pump motor for Kleenscreen filtering system draws 5.0 amps.

MODEL	KW PER FRYER SECTION <sup>3</sup>	AMPS - EACH FRYER SECTION (3 PHASE/ 60HZ) <sup>1</sup>					
		PER LINE			RECOMMENDED CIRCUIT PROTECTION <sup>2</sup>		
		208V	240V	480V	208V	240V	480V
ERD40F	14	39	34	17	50	45	25
	17	47	41	20	60	50	30
ERD50F	14	39	34	17	50	45	25
	17	47	41	20	60	50	30
	21	58	51	25	80	70	35
ERD225F	14	39	34	17	50	45	25
	17	47	41	20	60	50	30
	21	58	51	25	80	70	35
ERD85F	24	67	58	29	90	80	40
ERC40F	14	39	34	17	50	45	25
	17	47	41	20	60	50	30
ERC50F	14	39	34	17	50	45	25
	17	47	41	20	60	50	30
	21	58	51	25	80	70	35
ERC225F	14	39	34	17	50	45	25
	17	47	41	20	60	50	30
	21	58	51	25	80	70	35
ERC85F	24	67	58	29	90	80	40
<b>NOTES:</b>	<ol style="list-style-type: none"> <li>1. Amperage values in the table are nominal. Tolerance is +5/-10%.</li> <li>2. Complied in accordance with National Electric Code, ANSI/NFPA 70, latest edition.</li> <li>3. 14kw is standard on all fryers except 85 lb. models which are 24kw.</li> </ol>						

# REMOVAL AND REPLACEMENT OF PARTS

## COVERS AND PANELS

**WARNING:** DISCONNECT THE ELECTRICAL POWER TO THE MACHINE AT THE MAIN CIRCUIT BOX. THERE ARE SEVERAL SEPARATE CIRCUITS. BE SURE ALL ARE DISCONNECTED. PLACE A TAG ON THE CIRCUIT BOX(ES) INDICATING THE CIRCUIT IS BEING SERVICED.

### Front Control Panel

1. Open the cabinet door to the fryer section being serviced.
2. Remove the screws along the bottom lip and along the top of the of the control panel.



3. Work the panel loose at each end and lift off.
4. Reverse procedure to install.

### Basket lift Covers

1. Loosen bolt at the top of each basket lift hanger and lift the basket hangers from the support rod.
2. Remove the screws that secure the lower cover at the rear of the fryer section.
3. Remove the screws along each side of the cover.
4. Lift the cover and place to the side.
5. Reverse procedure to install.

## PUMP AND MOTOR

**WARNING:** DISCONNECT THE ELECTRICAL POWER TO THE MACHINE AT THE MAIN CIRCUIT BOX. THERE ARE SEVERAL SEPARATE CIRCUITS. BE SURE ALL ARE DISCONNECTED. PLACE A TAG ON THE CIRCUIT BOX(ES) INDICATING THE CIRCUIT IS BEING SERVICED.

**NOTE:** Refer to component location picture 6100 for location of pump motor.

1. Open the right side cabinet door of the filter section.
2. Pull the filter drawer out, remove the filter tank assembly and push the tank support arms back underneath the fryer.
3. Disconnect the electrical connection to the motor.

**NOTE:** The remaining steps are written for front removal of the pump assembly. If access to the back of the fryer is available, it may be easier to remove the pump from the rear.

4. Separate the swivel hose connection on the right side (intake) of the pump.
5. Separate the swivel hose connection on the left side (discharge) of the pump.
6. Remove the mounting bolts from the motor.
7. Remove the motor, pump and piping assembly.
  - A. If replacing the pump and motor, remove the existing piping assemblies and reuse.
8. Reverse procedure to install.

**NOTE:** Ensure the rubber vibration pad or the grommets are installed under the motor mounting plate.

## FILTER VALVE AND DISCARD VALVE SWITCHES

**WARNING:** DISCONNECT THE ELECTRICAL POWER TO THE MACHINE AT THE MAIN CIRCUIT BOX. THERE ARE SEVERAL SEPARATE CIRCUITS. BE SURE ALL ARE DISCONNECTED. PLACE A TAG ON THE CIRCUIT BOX(ES) INDICATING THE CIRCUIT IS BEING SERVICED.

1. Open the cabinet door to the fryer section being serviced.
2. Disconnect lead wire connector from the appropriate switch.
3. Remove switch mounting screws.
4. Reverse procedure to install.

**NOTE:** Switch mounting is a fixed location and has no provision for adjustment.

## HEATER CONTACTORS

**WARNING:** DISCONNECT THE ELECTRICAL POWER TO THE MACHINE AT THE MAIN CIRCUIT BOX. THERE ARE SEVERAL SEPARATE CIRCUITS. BE SURE ALL ARE DISCONNECTED. PLACE A TAG ON THE CIRCUIT BOX(ES) INDICATING THE CIRCUIT IS BEING SERVICED.

1. Remove the front control panel as outlined under "FRONT CONTROL PANEL" in "COVERS AND PANELS".
2. Remove the combination mounting and cover panel from the control area.



3. Contactors are now accessible.

**NOTE:** Refer to "COMPONENT LOCATION".

4. Reverse procedure to install.

# SERVICE PROCEDURES AND ADJUSTMENTS

## COMPUTER CONTROL BOARD DIAGNOSTICS

The computer control is used on other equipment and is capable of displaying many different prompts. Therefore, some prompts not applicable may display when a problem occurs in the wiring harness. Since the computer is looking for either 24 VAC or 24 VAC ground on particular pins, an open connection can cause a non-applicable prompt to appear. Refer to "COMPUTER CONTROL HARNESS PIN-OUTS CHART" under "TROUBLESHOOTING".

Diagnostics are divided into two areas, "OPERATION" and "SERVICE". Operation mode is the standard mode of fryer operation. Service mode is intended to give the service technician more information regarding the nature of a problem encountered. In either mode the fryer operates normally until an error occurs.

If an error occurs, the information displayed will be different. The chart below shows what is displayed for both "OPERATION" and "SERVICE" modes.

The "SERVICE" mode can only be entered while an error is occurring. To enter the service mode, press and hold the product 3 and 4 keys and turn the power switch ON. To exit, turn the power switch OFF.

The following displays/computer responses will be given for the noted conditions.

CONDITION	OPERATION MODE DIAGNOSTICS DISPLAY	SERVICE MODE DIAGNOSTICS DISPLAY	COMPUTER RESPONSE
No input on pins 3, 4, 5, or 6	IGN FAILURE	IGN FAILURE on left side or right side for split vat only	HEAT OFF
Low Temperature (lack of heat)	LOW TEMP	LO TEMP XXXF	HEAT OFF Temperature is below the lowest operational set point. Refer to "COMPUTER CONTROL" under "TROUBLESHOOTING".
High Temperature Alarm	HIGH TEMP	HI TEMP XXX°F	HIGH TEMP DISPLAYED Output at pin 15 and/or 16 (split vat) should already be OFF unless there is a problem with computer. Vat temperature is 410°F or higher which is well above the highest operational set point. Refer to "COMPUTER CONTROL" under "TROUBLESHOOTING".
High Temperature (high limit)	OFF	OFF	OFF DISPLAYED Mechanical high limit is OPEN (435°F), heat OFF and input is removed from pin 1 and/or pin 2 which indicates to the computer --- VAT TURNED OFF.
Tilt Switch OPEN	OFF	OFF	OFF DISPLAYED Heaters raised or problem with the tilt switch. Heat is OFF and input is removed from pin 1 and/or pin 2 which indicates to the computer --- VAT TURNED OFF.
Drain Valve Switch (if installed)	DRAIN OPEN	DRAIN OPEN	DRAIN OPEN DISPLAYED, HEAT OFF Input is removed from pin 10. Drain valve is OPEN or there is a problem with switch.
Probe Open or Short	CALL SERVICE	PROBE OPEN R or L for split vat PROBE SH R or L for split vat	HEAT OFF
No input on pin 11	CLOSE DOOR	CLOSE DOOR	HEAT OFF
Not passing Self Check	CALL SERVICE	MICRO FAIL	System will operate in backup mode



## Power up Diagnostics

On power up, the control will execute a self check. The failure of any of these tests will result in the message "CALL SERVICE" or "MICRO FAIL" being displayed.

This prompt will flash at approximately a 1 hertz rate. While the prompt is displayed, the computer will not function. If the failure is in the computer, the fryer will operate in backup mode.

When the fryer computer comes out of initialization and self check routines, it will either enter the heating mode or the melt mode (if programmed) of operation.

For a split vat fryer, one vat can be OFF while the other is in operation. If this occurs, the side that is OFF will be indicated by displaying the OFF prompt to the user. The message will be on the side of the display which corresponds to the vat which is OFF.

## System Tests

The system diagnostics menu is intended to give you the ability to test the basic parts of the computer. It can be entered by pressing the 8 and 9 product keys simultaneously while turning on power to the fryer computer. The message "SYSTEM TESTS" is displayed. In this mode you can select one of three tests.

With DISPLAY TEST displayed, press enter to begin a test, use the up and down arrows to rotate through the screens. Press exit once to return to the test menu or twice to return to normal operation.

With KEYPAD TEST displayed, press enter to begin the test. The control will respond by displaying the name of the key pressed. Press exit once to return to the test menu or twice to return to normal operation.

With VER xxx displayed, the release number is displayed as "VER XXX".

# ELECTRICAL OPERATION

## SEQUENCE OF OPERATION

### Solid State Fryer Control, Full Vat

Refer to schematic diagram TSP1567C for both the "Fryer Controls" operation and the "Kleenscreen Filtering system" operation.

#### FRY CYCLE - LIQUID FRYING OIL

**NOTE:** If using solid shortening, refer to "MELT CYCLE - SOLID SHORTENING" in this section.

#### 1. Conditions.

A. Fryer connected to correct supply voltage (separate connections are required for each section of the battery).

- 1) 208, 240 or 480VAC - power for heating elements.
- 2) 208 or 240VAC models - Step down transformer(s) provide power for the fryer controls, basket lift(s) if installed, and the Kleenscreen filtering controls.

3) 480VAC models - A separate 120VAC connection is used along with step down transformer(s) to provide power for the fryer controls, basket lift(s) if installed, and the Kleenscreen filtering controls.

4) All models require a separate 120VAC connection for the pump motor.

B. 24VAC transformer energized.

C. Fryer properly grounded.

D. Internal fryer circuit breakers ON.

**NOTE:** 208 and 240VAC models at 21 and 24 KW only.

E. Power switch to the fryer section controls in center NEUTRAL (starting) position.

F. Tilt switch contacts CLOSED (N.O. - held CLOSED with heating elements down).

G. Second high limit thermostat CLOSED.

H. Frying oil at the proper level in vat and below 300°F.

I. Fry/Melt switch in FRY position.

J. Temperature control set to desired frying temperature.

2. Press power ON switch.
  - A. 24VAC initially energizes relay coil R1 through the momentary ON power switch contacts (N.O.).
  - B. When switch is released, relay coil R1 remains energized through R1-2 "latching circuit" contacts (N.O.) and the momentary OFF power switch contacts (N.C.).
    - 1) R1-1 CLOSED.
    - 2) R1-2 CLOSED.
  - C. Supply voltage energizes the following components:
    - 1) Power ON light (red).
    - 2) Power supplied to basket lift controls, if installed.
    - 3) 1CON and 3CON through tilt switch and second high limit thermostat.
    - 4) Temperature control board at proper terminal (2, 3 or 4) for supply voltage and jumpered to terminal 5.
  - D. Temperature control board evaluates the inputs from thermistor and set point potentiometer then energizes the board relays.
    - 1) The Control relay contacts (N.O.) at terminal 5 CLOSE.
    - 2) The first high limit relay contacts (N.C.) at terminal 6 change state to the normally OPEN position and provide a path to the output at terminal 7.

**NOTE:** The first high limit "light" may quickly flash once, until the High limit relay is energized.

    - a. 2CON and 4CON are energized and heating elements are powered.
    - b. Heat light comes ON.

**NOTE:** Refer to "SCHEMATIC TSP1569C" under "SCHEMATIC DIAGRAMS".
3. Oil reaches set point temperature.
  - A. Temperature control de-energizes the "control relay" on board, contacts at terminal 5 OPEN and the output at terminal 7 is removed.
    - 1) 2CON and 4CON are de-energized and power is removed from the heating elements.
    - 2) Heat light goes OFF.
4. Temperature control cycles output to terminal 7 until power switch is turned OFF, heating elements are raised or a high limit condition occurs.
  - A. If oil reaches 410°F ±5, the temperature control de-energizes "high limit relay" on board, contacts revert back to the normally CLOSED position and the output changes to terminal 6.
    - 1) The first high limit light comes ON.
    - 2) 2CON and 4CON are de-energized and power is removed from the heating elements.
    - 3) Output is removed from terminal 6 when oil temperature drops below set point temperature and is returned to terminal 7.
  - B. If the second high limit OPENS (435°F ±15) or the tilt switch operates, 1CON and 3CON are de-energized and power is removed from the heating elements and heating stops.
    - 1) Trouble "light" and second high limit "light" come ON.

MELT CYCLE - SOLID SHORTENING

1. Conditions.
  - A. Same as outlined in steps 1A thru 1G under "FRY CYCLE - LIQUID FRYING OIL".
  - B. Solid shortening at the proper pounds in vat and at room temperature.
  - C. Fry/Melt switch in MELT position.
  - D. Temperature Control set to desired frying temperature.
2. Same as outlined in steps 2 thru 2. C. 4) under "FRY CYCLE - LIQUID FRYING OIL".
3. Temperature control board evaluates the inputs from thermistor then energizes the board relays.
  - A. Melt cycle is initiated and the temperature control functions as a percent ON/OFF timer.
    - 1) The control relay contacts (N.O.) at terminal 5, cycle the output at terminal 7 to energize 2CON and 4CON and power the heating elements.
      - a. Initial condition is OFF 45 seconds.
      - b. Heat condition ON 2 seconds (heat light ON).

**NOTE:** Refer to "SCHEMATIC TSP1569C" under "SCHEMATIC DIAGRAMS".

- B. Control cycles output at time intervals of 30 seconds OFF, then 2 seconds ON (heat light ON).
- 4. Shortening temperature reaches 135°F.
  - A. Melt cycle is automatically over-ridden.
- NOTE:** The Fry/Melt switch should remain in the "Melt" position.
- B. Control uses thermistor input to cycle the output at terminal 7.
- 5. Shortening reaches set point temperature.
  - A. Control removes output from pin 7.
    - 1) 2CON and 4CON are de-energized and power is removed from the heating elements.
    - 2) Heat light goes out.
- 6. Control cycles the output at terminal 7, on the vat temperature.

**Computer Control, Full Vat**

Refer to schematic diagram's TSP1571C for "Fryer Controls" operation and TSP1587 "Kleenscreen Filtering system" operation.

**FRY CYCLE - LIQUID FRYING OIL**

**NOTE:** If using solid shortening, the computer control should be programmed to use the MELT CYCLE. In the MELT CYCLE, the computer will "cycle" the heaters ON/OFF in short intervals to gradually heat and liquify the shortening until it reaches a temperature of 135°F. The computer then resumes normal operation as described under FRY CYCLE.

- 1. Conditions.
  - A. Fryer connected to correct supply voltage (separate connections are required for each section of the battery).
    - 1) 208, 240 or 480VAC - power for heating elements.
    - 2) 208 or 240VAC models - Step down transformer(s) provide power for the fryer controls, basket lift(s) if installed, and the Kleenscreen filtering controls.
    - 3) 480VAC models - A separate 120VAC connection is used along with step down transformer(s) to provide power for the fryer controls, basket lift(s) if installed, and the Kleenscreen filtering controls.

- 4) All models require a separate 120VAC connection for the pump motor.

- B. 24VAC transformer 2T energized.
  - 1) Power to pins 3, 4, 5, 6, 11, and 17 (control system main input) on computer main harness.
  - 2) 24 VAC ground to pins 9, 12, and 13 (control system main input GND).

**NOTE:** Pin 12 on the main harness is used to indicate to the computer the type of fryer (full or split vat) the computer is installed in. If the fryer is a full vat, pin 12 is tied to 24 VAC ground. If the fryer is a split vat, pin 12 is tied to 24 VAC.

- C. Fryer properly grounded.
- D. Internal fryer circuit breakers ON.

**NOTE:** 208 and 240VAC models at 21 and 24 KW only.

- E. Power switch to the fryer section controls in the OFF position.
- F. Tilt switch contacts CLOSED (N.O. - held CLOSED with heating elements down).
- G. Second high limit thermostat CLOSED.
- H. Frying oil at the proper level in vat and below 300°F.
- I. Computer control is setup properly and ready to use.

2. Press power ON switch.

- A. 12VAC transformer 1T energized.
  - 1) Computer power supply board PS-1 is energized and a (+) 12VDC signal is sent to pin 23 on the computer main harness.
- B. Computer control powers ON, initializes and performs a diagnostic self check.

**NOTE:** If the control passes self check, then the outputs are energized and operation sequence continues. If control does not pass self test then CALL SERVICE or MICRO FAIL will display. Refer to "COMPUTER CONTROL BOARD DIAGNOSTICS" under "SERVICE PROCEDURES AND ADJUSTMENTS".

- 1) R1 control relay, 1CON and 3CON will energize.
  - a. R1 relay energized, NO contacts CLOSE and supply power to pin 1 on computer main harness.

**NOTE:** Pins 1 and 2 on the main harness are used to monitor the power switch "status" of the vat(s). Pin 1 is the power status input on a full vat or right side split vat and pin 2 is the input for the left side split vat only. These inputs tell the computer which vat(s) are turned ON or OFF.

3. Computer control evaluates input from thermistor at pins 3 and 4 (full vat or right side split vat).

**NOTE:** Pins 1 and 2 (left side split vat only) on temperature probe harness.

- A. Computer control evaluates the input from thermistor then activates the 24VAC output from pin 15 and power is applied to R2 control relay.

- 1) R2 control relay is energized and the N.O. contacts CLOSE.
  - a. 2CON and 4CON are energized and heating elements are powered.

**NOTE:** Pin 15 and 16 on the main computer harness are the heat outputs. Pin15 is the full vat or right side split vat output and pin 16 is the left side output on a split vat only.

4. Oil temperature reaches set temperature.
  - A. Computer turns OFF heat output and control relay R2 de-energizes.
  - B. 2CON and 4CON are de-energized and power is removed from heating elements.
5. Computer cycles heat output on oil temperature until power switch is turned OFF, heating elements are raised or a high limit condition occurs.

**NOTE:** Steps 5A and 5B discuss OPEN high limits. For additional information on computer control error messages, refer to "COMPUTER CONTROL BOARD DIAGNOSTICS" under "SERVICE PROCEDURES AND ADJUSTMENTS".

- A. If the oil reaches 410°F ±5, the display will indicate "HI TEMP" as an alarm to the operator only.
- B. If the second high limit (435°F ±15) OPENS or the tilt switch operates, the control relay R1 and contactors 1 thru 4 are de-energized.
  - 1) Power is removed from the heating elements and heating stops.

- 2) R1 contacts OPEN and remove power from pin 1 (full vat or right side split vat). The display will indicate "OFF".

**NOTE:** If the second high limit trips for the left side split vat only, R3 and contactors 3 and 4 are de-energized. Power is removed from the left side vat heating elements only and heating stops. R3 contacts OPEN and remove power from pin 2 (left side split vat only). The display will indicate "OFF" for the left side vat.

**NOTE:** The filter valve handle and the discard valve handle are connected to a mechanical valve and switch assembly to route the flow of oil filtering system and supply power to the pump motor.

### Kleenscreen Filtering System

For Solid State Control, refer to schematic diagram TSP1567C for both the "Fryer Controls" operation and the "Kleenscreen Filtering system" operation.

For Computer Control, refer to schematic diagrams TSP1571C for the "Fryer Controls" operation and TSP1587C for the "Kleenscreen Filtering system" operation.

1. Conditions
  - A. Fryer connected to correct supply voltage (separate connections are required for each section of the battery).
  - B. Fryer properly grounded.
  - C. Power switch to fryer section controls turned OFF.
  - D. Frying oil below 300°F.
  - E. Filter drawer assembly installed properly.
  - F. Filter power switch turned OFF.
  - G. Filter valve handle (red) retracted.
    - 1) Filter valve switch N.O. contacts OPEN.
  - H. Discard valve handle (white) retracted.
    - 1) Discard valve switch N.O. contacts OPEN.
2. Set temperature control between 300°F (minimum) and 350°F (maximum).
 

**NOTE:** Oil should not be filtered outside of this temperature range. At lower temperatures the oil is thicker which may increase filtering time and place a greater load on the pump. At higher oil temperatures, oil seal life is decreased.

  3. Turn the power switch ON, to the fryer section to be filtered.

- A. Allow oil to cycle at set temperature for approximately 10 minutes.

**NOTE:** If using solid shortening, once it has melted, stir the oil to eliminate any sold shortening in cold zone of the vat. Refer to "MELT CYCLE - SOLID SHORTENING".

4. Turn the power switch OFF, to the fryer section to be filtered.
5. Open the manual drain valve to the fryer section in need of filtering and drain the liquid oil/shortening into filter tank.

**NOTE:** If using solid shortening, allow hot shortening to stand in filter tank for approximately 6 minutes prior to filtering.

6. Turn filter power switch ON.
- A. Switch pilot light comes ON.
7. Extend Filter valve handle of the same fryer section.
- A. Filter valve switch N.O. contacts CLOSE.
- 1) Filter relay coil is energized and the N.O. contacts CLOSE.
- a. Power supplied to pump motor.
- B. Pump motor circulates oil through filter until power is removed.
8. When the oil filtering process is completed, close the manual drain valve to the fryer and allow the vat to refill.

**NOTE:** No electrical switching occurs by closing the manual drain valve unless the optional drain valve switch is installed.

9. When all filtered oil is returned to the fryer, retract the filter valve handle.
- A. Filter valve switch N.O. contacts OPEN.
- 1) Filter relay coil is de-energized and the N.O. contacts OPEN.
- a. Power is removed from pump motor.
10. Turn filter power switch OFF.

**NOTE:** If using solid shortening, when all filtered oil is returned to the vat and filter power switch is OFF, open the filter drawer approximately one inch. Allow the remaining shortening in the line to drain into the filter tank to prevent possible clogging after the shortening cools and solidifies. Close the filter drawer when complete.

### Discard of used oil

1. Conditions
- A. Same as outlined in steps 1 thru 4 under "KLEENSCREEN FILTERING SYSTEM".
2. Open the manual drain valve to the fryer section in need of oil discarding and drain the oil into the filter.
3. Attach oil drain hose the male quick connect fitting on the fryer.
4. Turn filter power switch ON.
- A. Switch pilot light comes ON.
5. Place drain hose discharge end into a used oil holding tank.
6. Extend discard handle.
- A. Discard valve switch N.O. contacts CLOSE.
- 1) Filter relay coil is energized and the N.O. contacts CLOSE.
- a. Power supplied to pump motor.
- B. Oil begins flowing through drain hose into holding tank until power is removed.
7. When all used oil is emptied from the fryer, retract the discard valve handle.
- A. Discard valve switch N.O. contacts OPEN.
- 1) Filter relay coil is de-energized and the N.O. contacts OPEN.
- a. Power is removed from pump motor.
8. Close the manual drain valve to the fryer.
- NOTE:** No electrical switching occurs by closing the manual drain valve unless the optional drain valve switch is installed.
9. Turn filter power switch OFF.
- NOTE:** If using solid shortening, when all filtered oil is returned to the vat and filter power switch is OFF, open the filter drawer approximately one inch. Allow the remaining shortening in the line to drain into the filter tank to prevent possible clogging after the shortening cools and solidifies. Close the filter drawer when complete.

## COMPONENT FUNCTION

**NOTE:** For components not listed here, refer to the ER series service manual listed on the front cover and under "INFORMATION SOURCES" in the "GENERAL" section.

<b>Filter Power Switch</b> . . . . .	Supplies 120VAC to pump motor when filter relay is energized.
<b>Filter Relay</b> . . . . .	Supplies 120VAC to pump motor through filter relay contacts (N.O.) when 24VAC coil is energized. Filter power switch must be ON and the filter valve switch or discard valve switch must be CLOSED (valve handle extended).
<b>Transformer 2T</b> . . . . .	Supplies 24VAC to the oil filter control circuit and fryer power switch. Transformer is energized when supply power is connected to fryer.
<b>Transformer 1T</b> . . . . .	Supplies 12VAC to the computer power supply board. Transformer is energized when fryer power switch is turned ON. Computer control models only.
<b>Pump Motor</b> . . . . .	Operates the "pump" to circulate oil through the filtering system.
<b>Filter Valve Switch</b> . . . . .	Energizes the filter relay coil to supply power to the pump motor through filter relay contacts (N.O.) when switch is CLOSED (valve handle extended). When oil filtering is complete, close the manual drain valve to the fryer and allow the vat to refill. Retract the filter handle when all filtered oil is returned.
<b>Discard Valve Switch</b> . . . . .	Energizes the filter relay coil to supply power to the pump motor through filter relay contacts (N.O.) when switch is CLOSED (valve handle extended). This allows the oil to be discarded through the discard hose into a separate container. When filter tank is empty, retract the handle to return the discard switch to normal operating position.
<b>Fryer Power Switch</b> . . . . .	Energizes relay coil R1 and supplies power to fryer control circuit through relay R1-1 contacts (N.O.). The switch positions are: momentary ON, momentary OFF with a center NEUTRAL (starting) position. Solid state controls only.  Circuit 1 on the switch is the normally CLOSED (N.C.) side. Press power OFF to momentarily OPEN switch contacts and turn the fryer OFF.  Circuit 2 on the switch is the normally OPEN (N.O.) side. Press power ON to momentarily CLOSE switch contacts and turn the fryer ON.
<b>Relay R1</b> . . . . .	Supplies power to fryer control circuit and basket lift circuit (if installed) through relay R1-1 contacts (N.O.) when 24VAC coil is energized. The relay remains energized through R1-2 contacts (N.C.) and fryer power switch contacts until power switch is turned OFF. Full vat and split vat fryers, solid state controls only.
<b>Relay R2</b> . . . . .	Supplies power to fryer control circuit and basket lift circuit (if installed) through relay R2-1 contacts (N.O.) when 24VAC coil is energized. The relay remains energized through R2-2 contacts (N.C.) and fryer power switch contacts until power switch is turned OFF. Split vat fryers with solid state controls only.

**COMPONENT LOCATION**

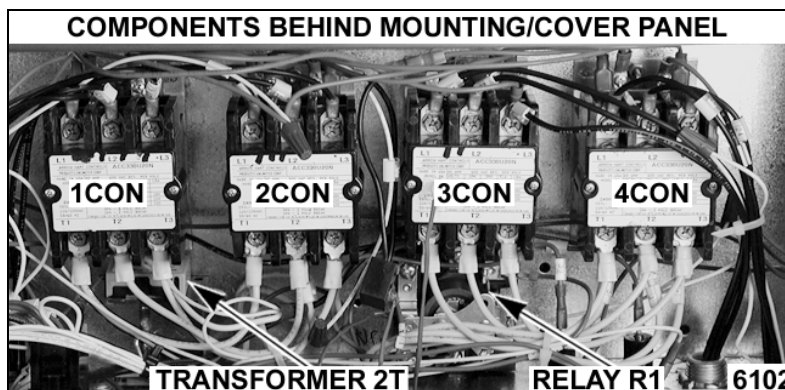
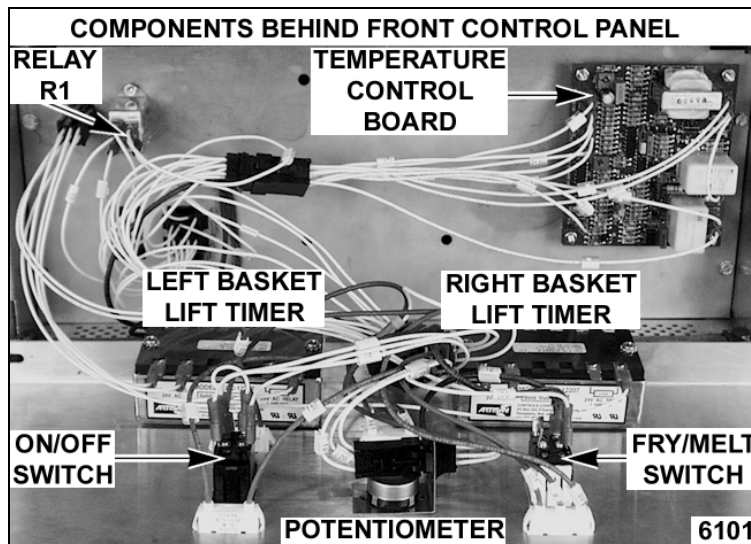
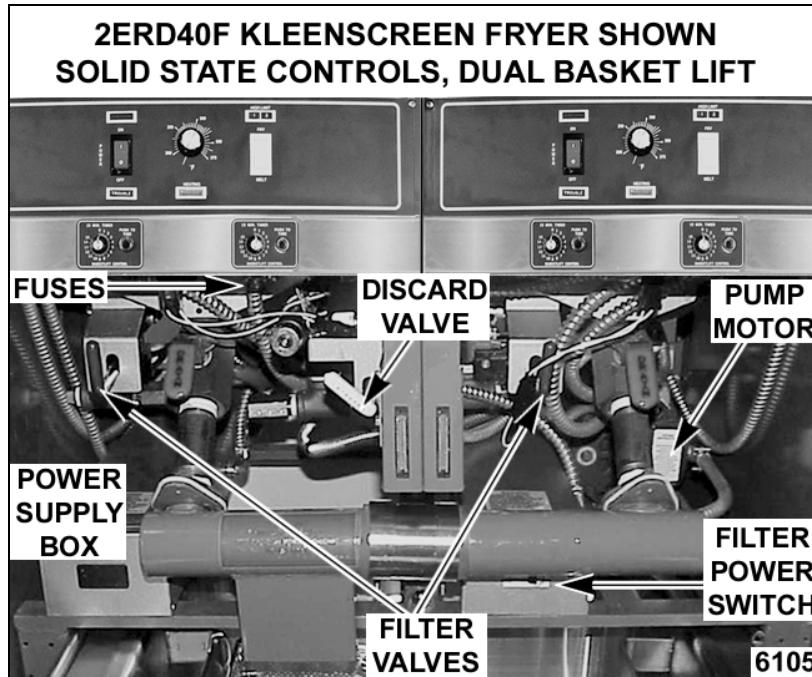

# SCHEMATIC DIAGRAMS

## Solid State Control and Kleenscreen Filter, Full Vat

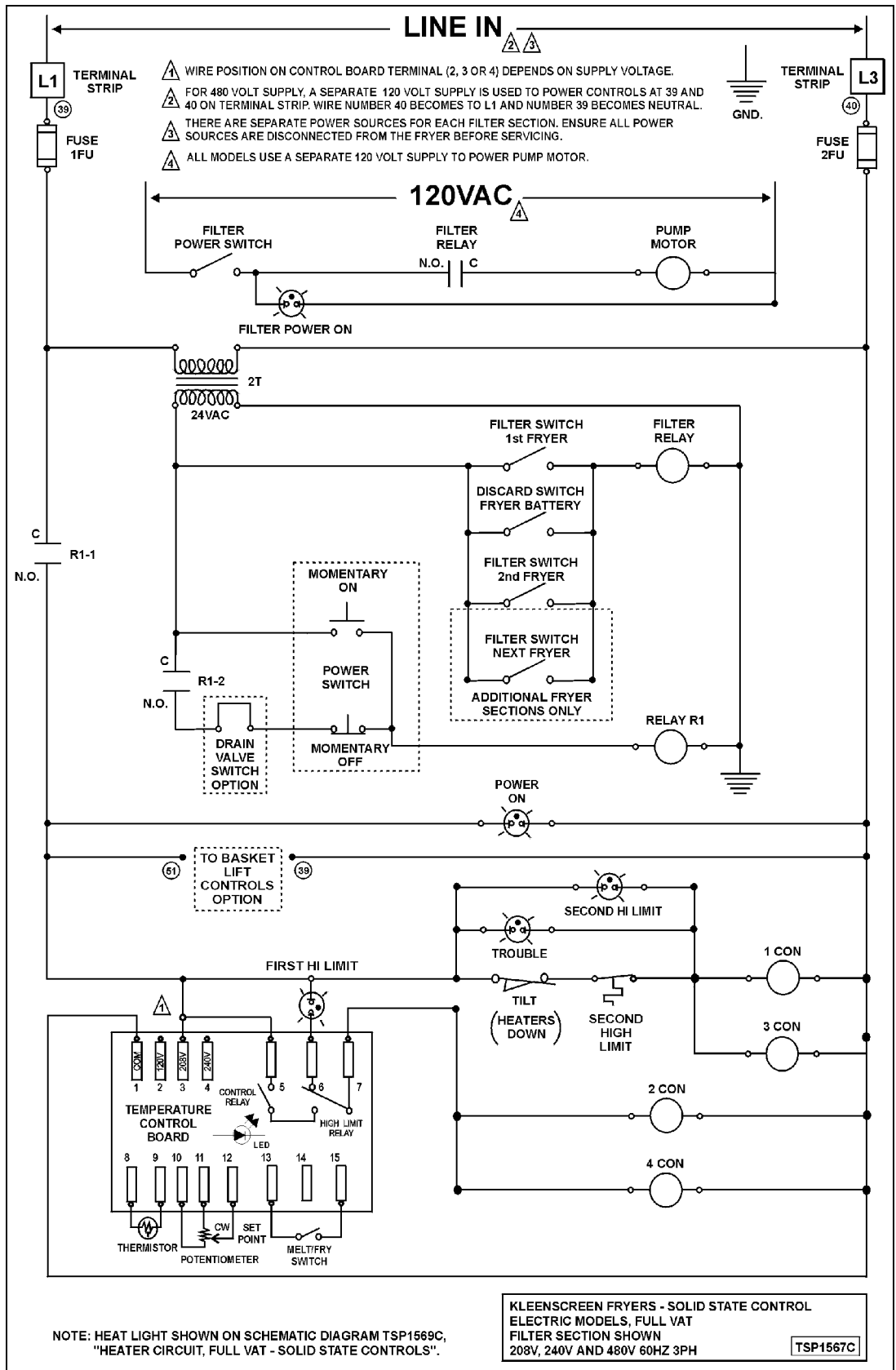



Solid State Control and Kleenscreen Filter, Split Vat

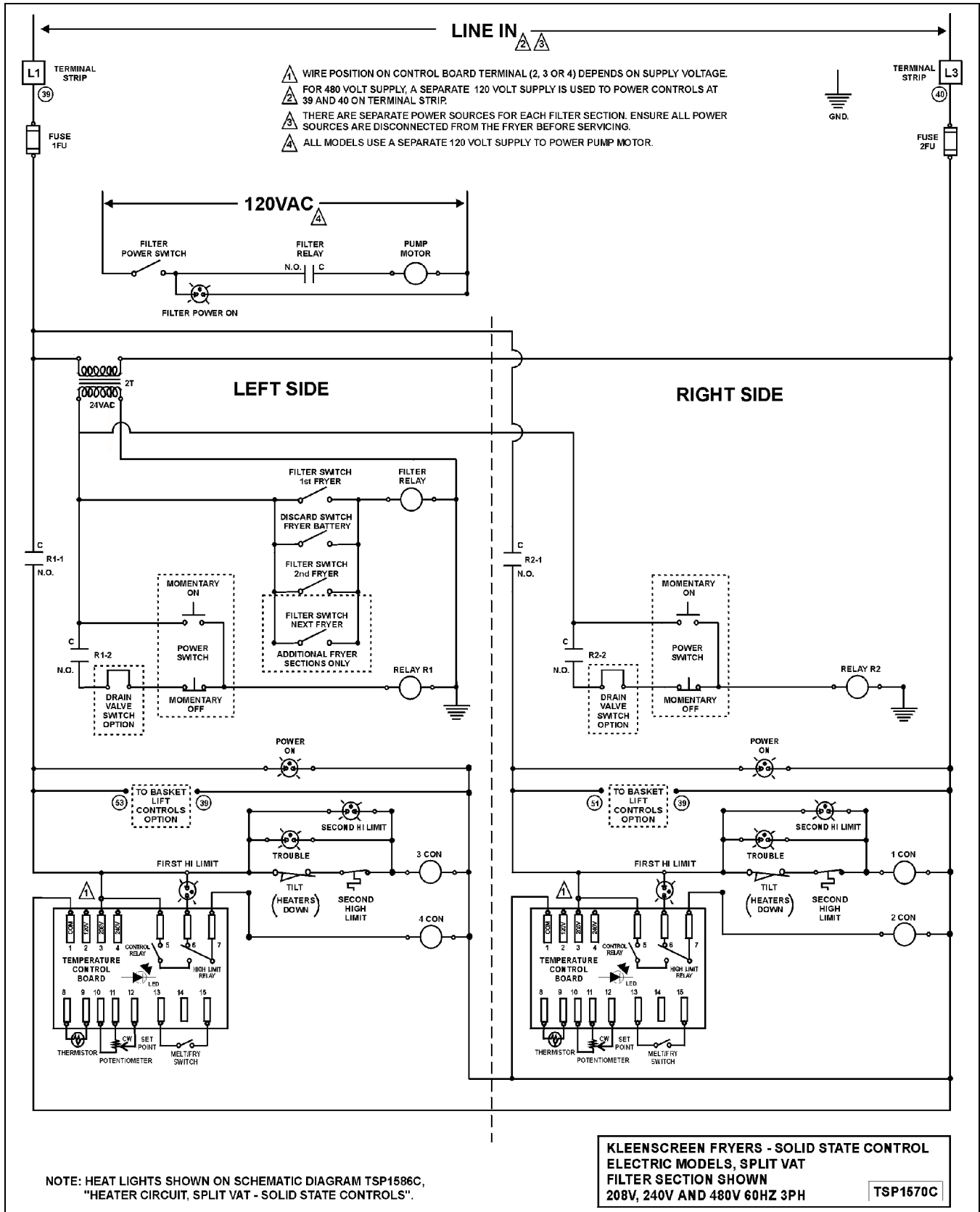

Computer Control, Full Vat

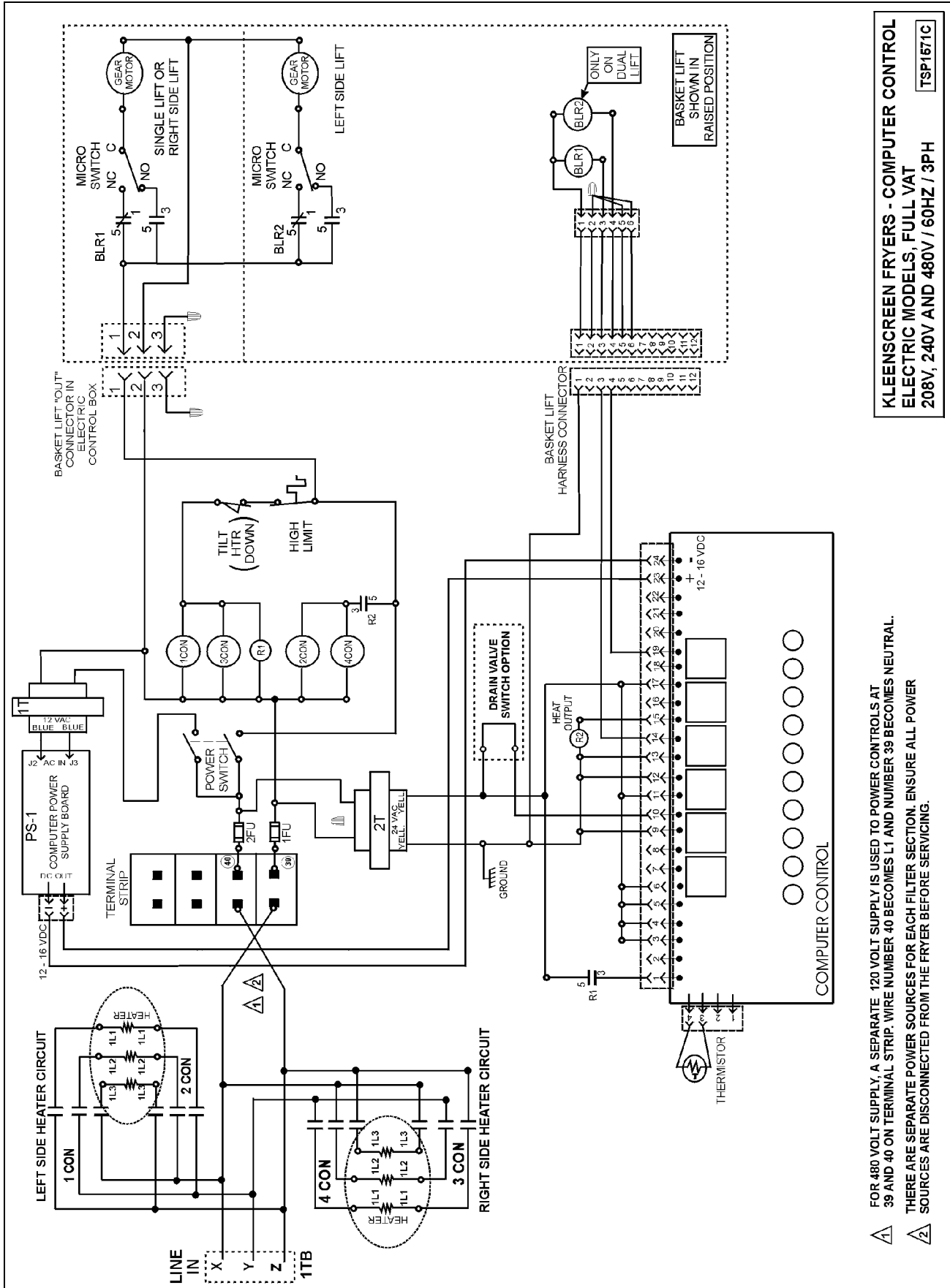

**KLEENSCREEN FRYERS - COMPUTER CONTROL  
ELECTRIC MODELS, FULL VAT  
208V, 240V AND 480V / 60HZ / 3PH  
TSP1671C**

⚠️ FOR 480 VOLT SUPPLY, A SEPARATE 120 VOLT SUPPLY IS USED TO POWER CONTROLS AT 39 AND 40 ON TERMINAL STRIP. WIRE NUMBER 40 BECOMES L1 AND NUMBER 39 BECOMES NEUTRAL.  
⚠️ THERE ARE SEPARATE POWER SOURCES FOR EACH FILTER SECTION. ENSURE ALL POWER SOURCES ARE DISCONNECTED FROM THE FRYER BEFORE SERVICING.

Computer Control, Split Vat

⚠ FOR 480 VOLT SUPPLY, A SEPARATE 120 VOLT SUPPLY IS USED TO POWER CONTROLS AT 39 AND 40 ON TERMINAL STRIP. WIRE NUMBER 40 BECOMES L1 AND NUMBER 39 BECOMES NEUTRAL.

⚠ THERE ARE SEPARATE POWER SOURCES FOR EACH FILTER SECTION. ENSURE ALL POWER SOURCES ARE DISCONNECTED FROM THE FRYER BEFORE SERVICING.

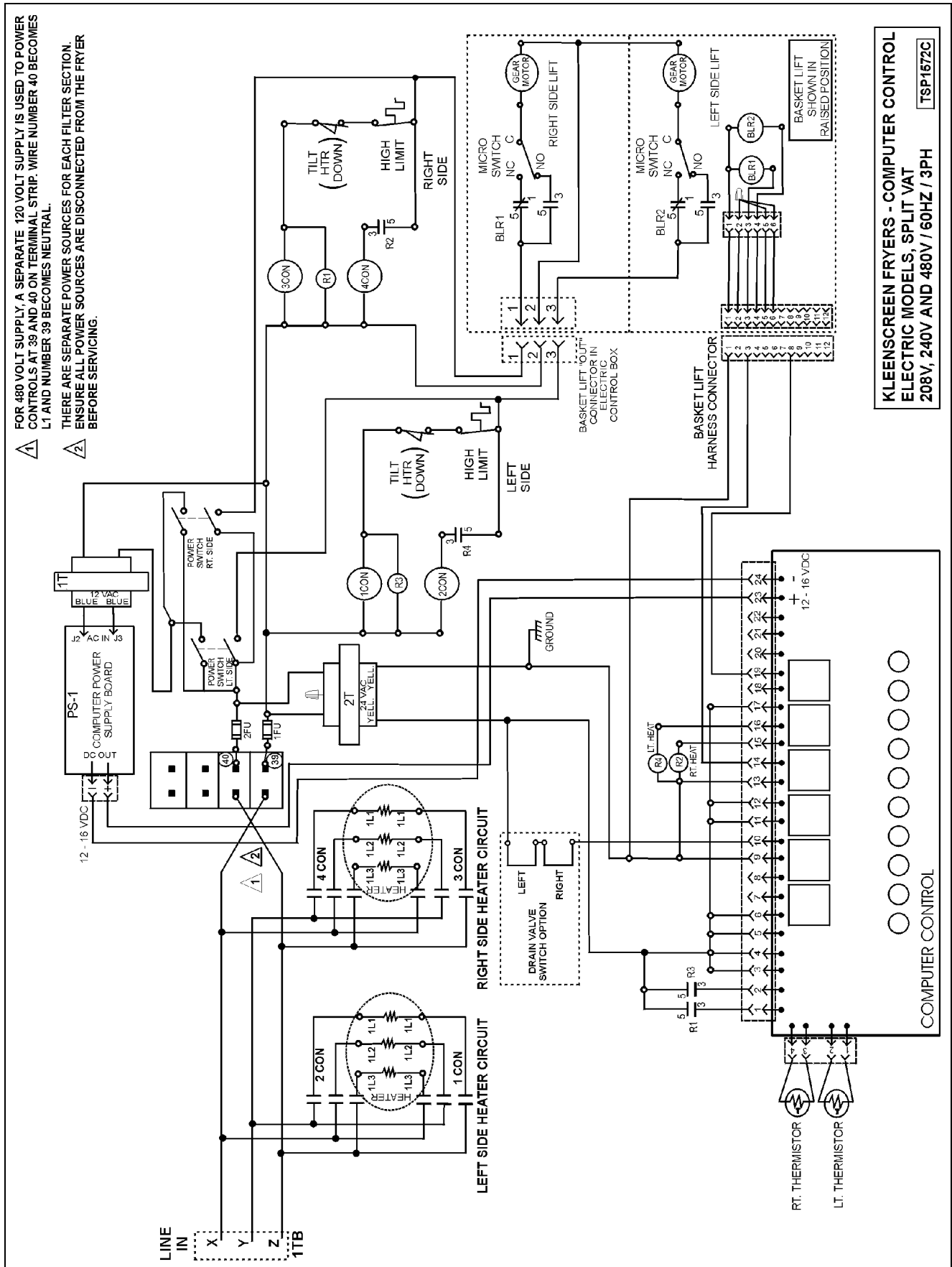

**KLEENSCREEN FRYERS - COMPUTER CONTROL**  
**ELECTRIC MODELS, SPLIT VAT**  
**208V, 240V AND 480V / 60HZ / 3PH**  
**TSP1672C**

Kleenscreen Filtering System, Computer Control

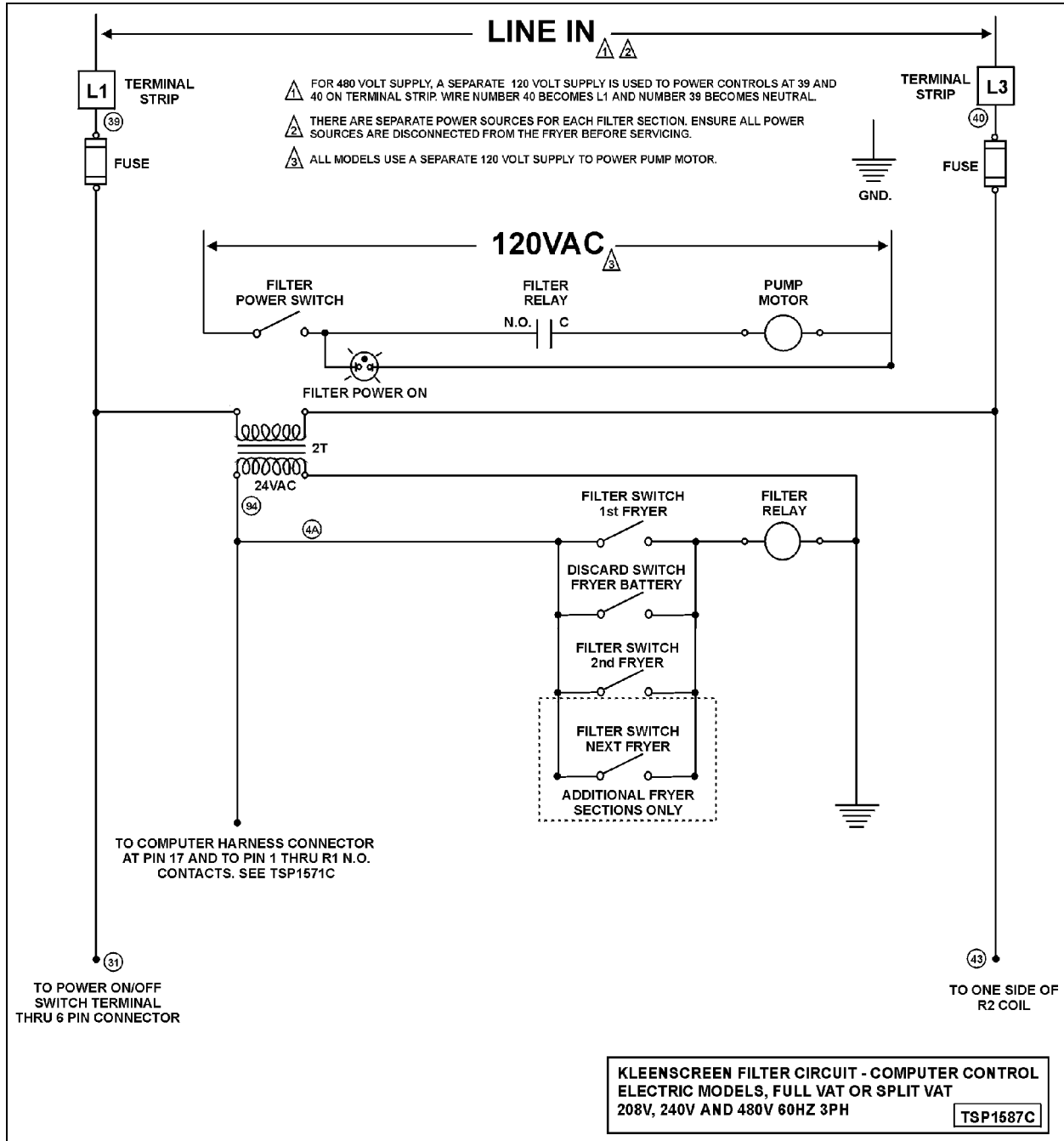

Heater Circuit, Solid State Controls, Full Vat

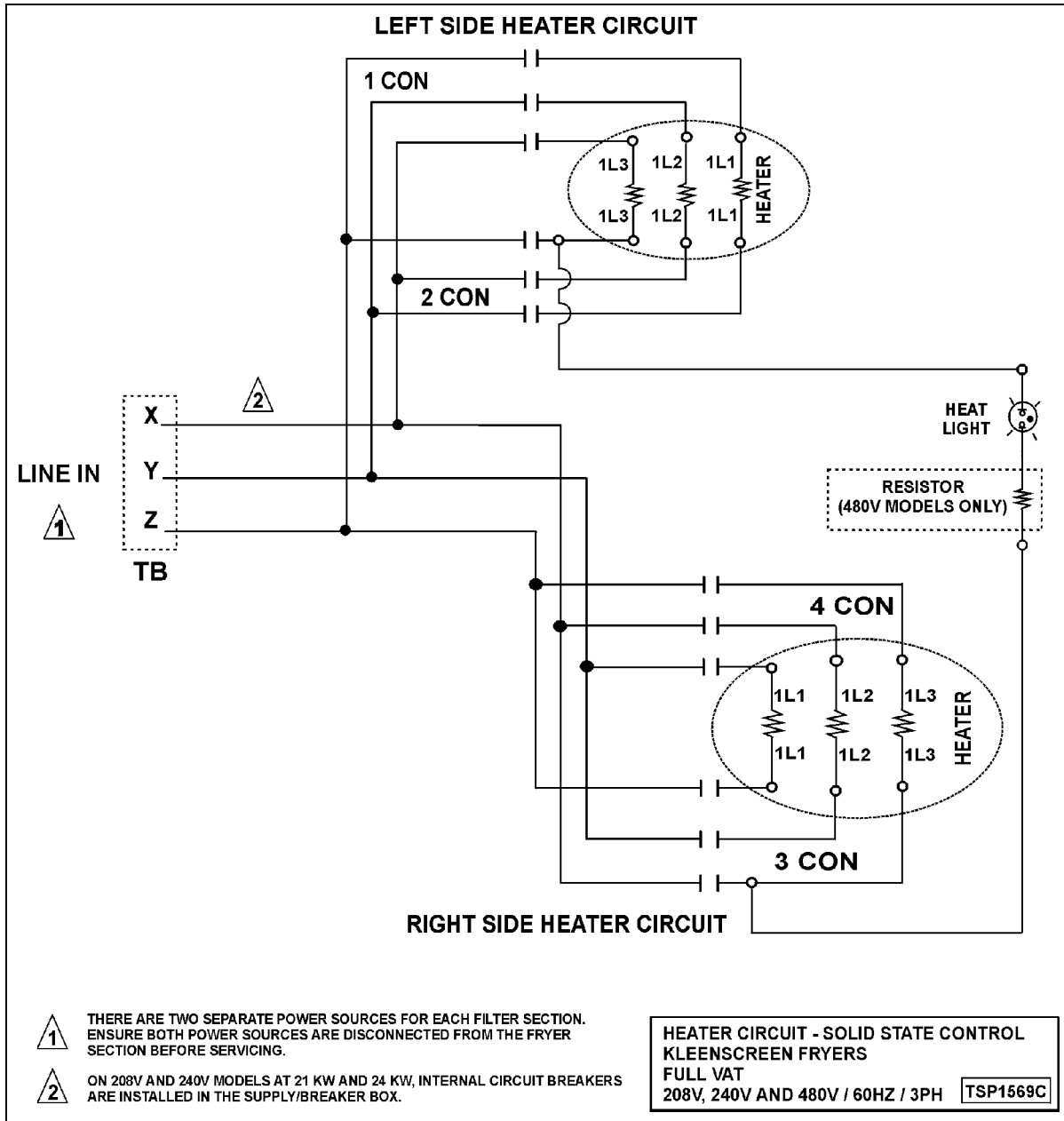

Heater Circuit, Solid State Controls, Split Vat

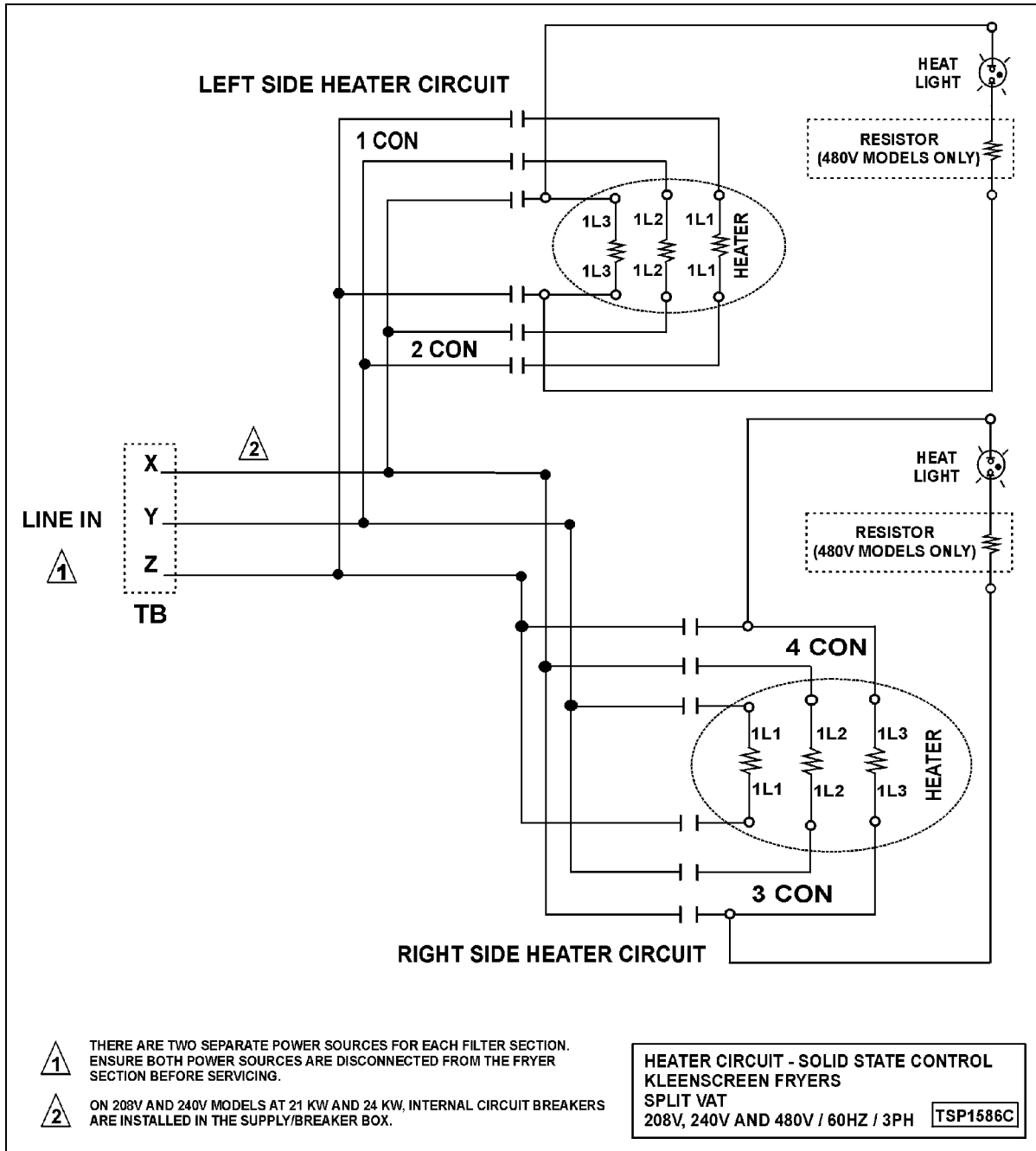

Basket Lift Circuit, Solid State Controls

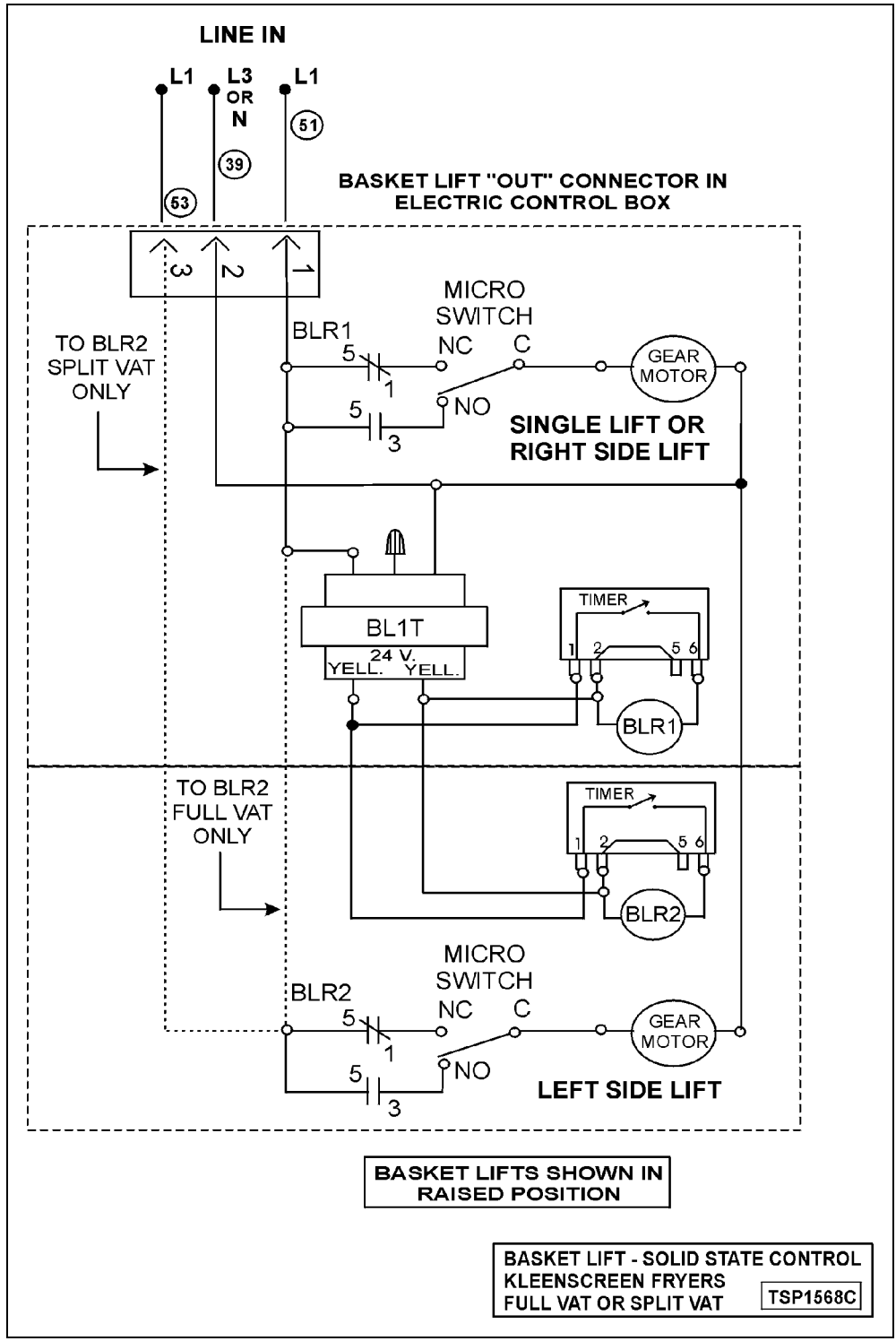

## WIRING DIAGRAMS

### Kleenscreen Filtering System

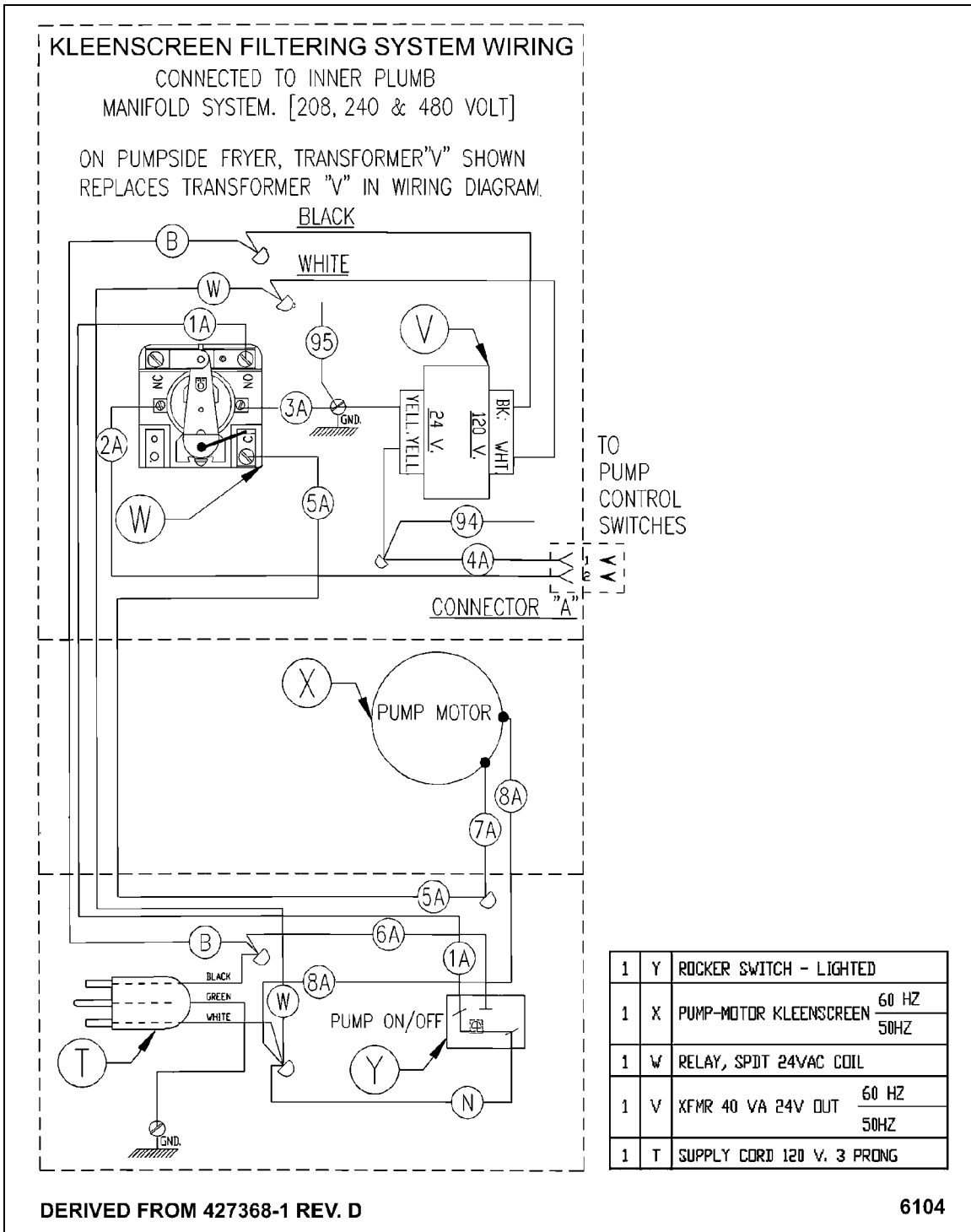



**Wiring Diagram Index**

SOLID STATE CONTROL, KLEENSCREEN

Full-Vat, 208 & 240 Volt 24 & 21 KW ..... 26 & 27

Full-Vat, 208 & 240 Volt 17 & 14 KW ..... 28 & 29

Full-Vat, 480 Volt 24, 21, 17 & 14 KW ..... 30 & 31

Split-Vat, 208 & 240 Volt 17 & 14 KW ..... 32 & 33

Split-Vat, 208 & 240 Volt 21 KW ..... 34 & 35

Split-Vat, 480 Volt 14, 17 & 21 KW ..... 36 & 37

COMPUTER CONTROL, KLEENSCREEN

Full-Vat, 208 & 240 Volt 17 & 14 ..... 38 & 39

Full-Vat, 208 & 240 Volt 24 & 21 KW ..... 40 & 41

Full-Vat, 480 Volt 24, 21, 17 & 14 KW ..... 42 & 43

Split-Vat, 208 & 240 Volt 17 & 14 KW ..... 44 & 45

Split-Vat, 208 & 240 Volt 21 KW ..... 46 & 47

Split-Vat, 480 Volt 21, 17 & 14 KW ..... 48 & 49

208-240 VOLT PHASE LOAD

TOTAL KW	KW/PHASE		
	X-Y	X-Z	Y-Z
24	8	8	8
21	7	7	7
AMPS PER LINE 208 VOLT			
	X	Y	Z
24	67	67	67
21	58	58	58
AMPS PER LINE 240 VOLT			
	X	Y	Z
24	58	58	58
21	51	51	51

REQ.	REQ.	IT.	DESCRIPTION	FIN.
1	1	F1	FILTER ASSEMBLY SINGLE	-
1	1	Z	SWITCH, LIMIT TILT	-
1	1	W	RELAY DPDT 24V COIL	-
1	1	V	TRANSFORMER, 40 VA 24V.	240V.SYS 120V.SYS
1	1	T	2ED HIGH LIMIT 435 F	-
2	-	S	ELEMENT, FIREBAR 12KW	208 V. 240 V.
-	2	R	ELEMENT, FIREBAR 10.5KW	208 V. 240 V.
2	2	P	FUSE & HOLDER	HOLDER FUSE
1	1	N	THERMISTOR PROBE	-
2	2	M	CIRCUIT BREAKER 50A 3 POLE	-
1	1	K	TEMPERATURE CONTROL BOARD	-
1	1	J	POTENTIOMETER ASSEMBLY	-
1	1	H	LIGHT, INDICATOR 'TROUBLE'	-
1	1	G	LIGHT, INDICATOR AMBER (HEAT)	-
1	1	F	LIGHT, INDICATOR RED (POWER)	-
1	1	E	LIGHT, INDICATOR (1 2) (HIGH LIMIT)	-
1	1	DI	SWITCH, ROCKER DPDT MDN ON/OFF	-
1	1	D	SWITCH, ROCKER DPST (FRY/MELT)	-
4	4	C	CONTACTOR 3P 40A 230V COIL	-
1	1	B	STRIP-TERMINAL BARRIER	-
1	1	A	TERMINAL BLOCK	-

24 KW FRYER  
21 KW FRYER

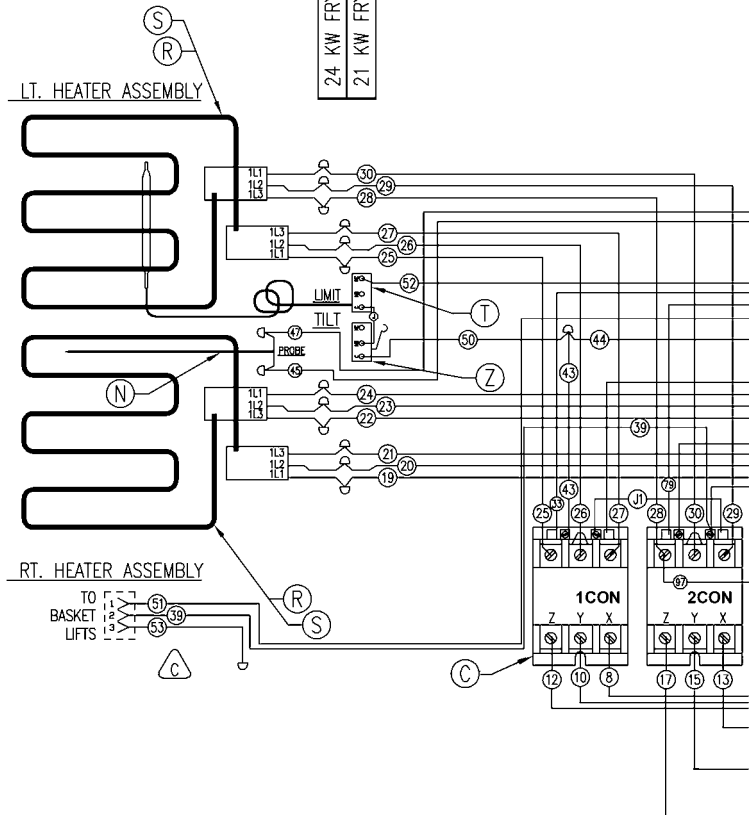

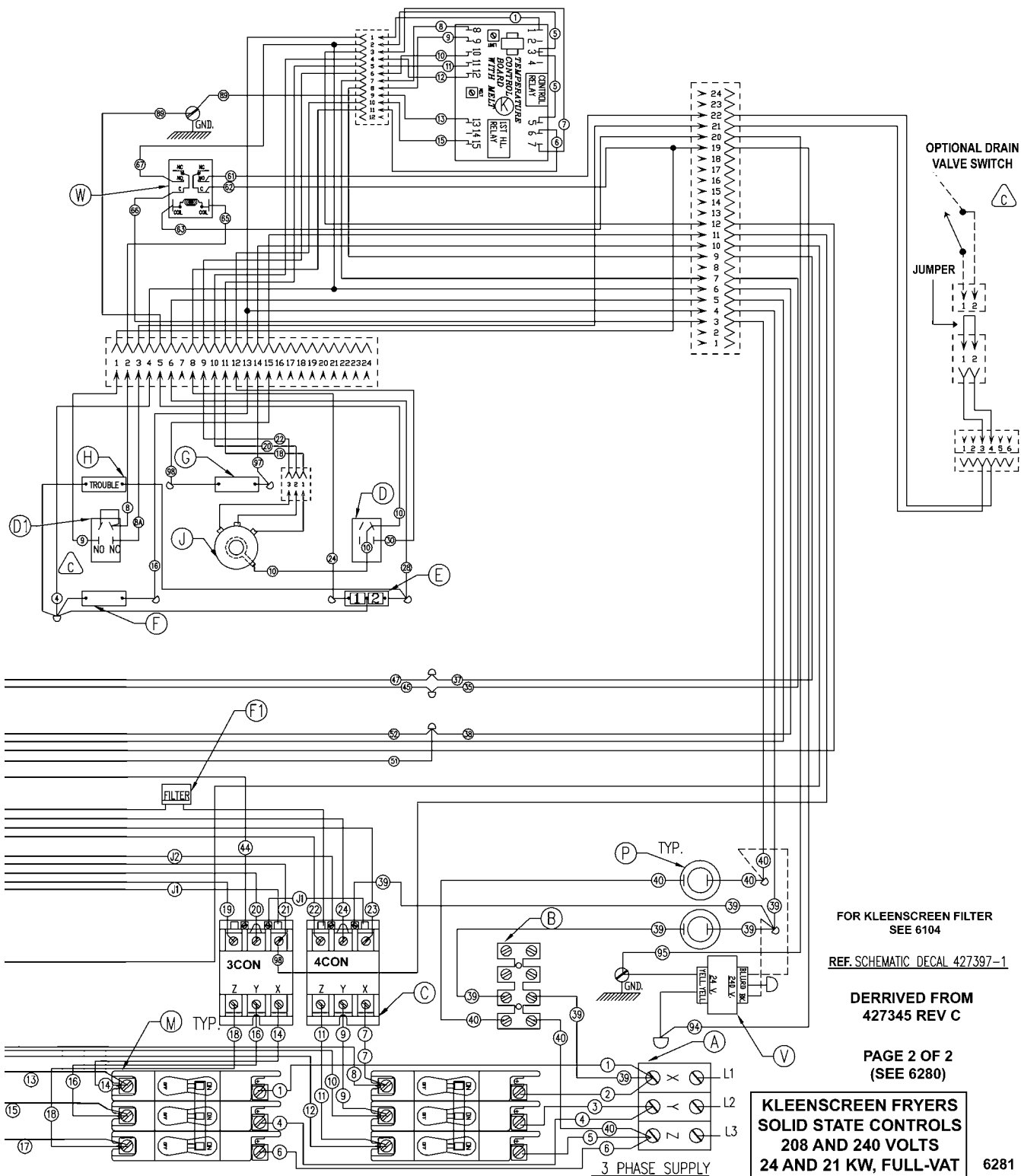

FOR KLEENSCREEN FILTER  
SEE 6104

REF. SCHEMATIC DECAL 427397-1

DERIVED FROM  
427345 REV C

PAGE 2 OF 2  
(SEE 6280)

**KLEENSCREEN FRYERS  
SOLID STATE CONTROLS  
208 AND 240 VOLTS  
24 AND 21 KW, FULL-VAT**

6281

208-240 VOLT PHASE LOAD

TOTAL KW	KW/PHASE		
	X-Y	X-Z	Y-Z
17	5.6	5.6	5.6
14	4.6	4.6	4.6
AMPS PER LINE 208 VOLT			
	X	Y	Z
17	47	47	47
14	39	39	39
AMPS PER LINE 240 VOLT			
	X	Y	Z
17	41	41	41
14	34	34	34

REQ.	REQ.	IT.	DESCRIPTION	FIN.
1	1	F1	FILTER ASSEMBLY SINGLE	-
1	1	Z	SWITCH, LIMIT TILT	-
1	1	W	RELAY DPDT 24V COIL	-
1	1	V	TRANSFORMER, 40 VA 24V.	240V.SYS 120V.SYS
1	1	T	2ED HIGH LIMIT 435 F	-
2	-	S	ELEMENT, FIREBAR 8.5KW	208 V. 240 V.
-	2	R	ELEMENT, FIREBAR 7KW	208 V. 240 V.
2	2	P	FUSE & HOLDER	HOLDER FUSE
1	1	N	THERMISTOR PROBE	-
1	1	K	TEMPERATURE CONTROL BOARD	-
1	1	J	POTENTIOMETER ASSEMBLY	-
1	1	H	LIGHT, INDICATOR 'TROUBLE'	-
1	1	G	LIGHT, INDICATOR AMBER (HEAT)	-
1	1	F	LIGHT, INDICATOR RED (POWER)	-
1	1	E	LIGHT, INDICATOR [ 2 ] (HIGH LIMIT)	-
1	1	DI	SWITCH, ROCKER DPDT MOM ON/OFF	-
1	1	D	SWITCH, ROCKER DPST (FRY/MELT)	-
4	4	C	CONTACTOR 3P 40A 230V COIL	-
1	1	B	STRIP-TERMINAL BARRIER	-
1	1	A	TERMINAL BLOCK	-

17 KW FRYER  
14 KW FRYER

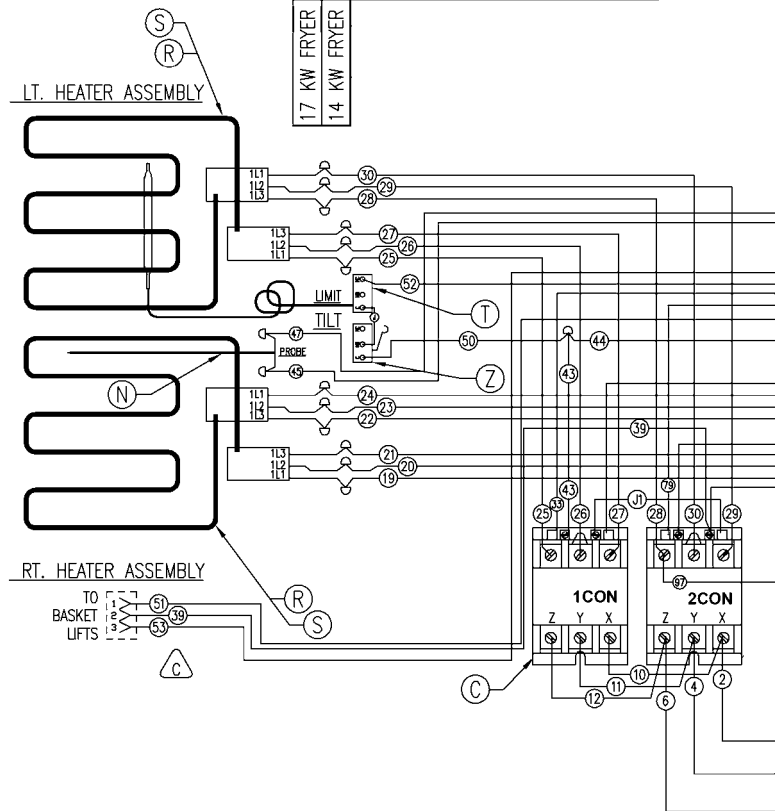

PAGE 1 OF 2  
(SEE 6283)

6282

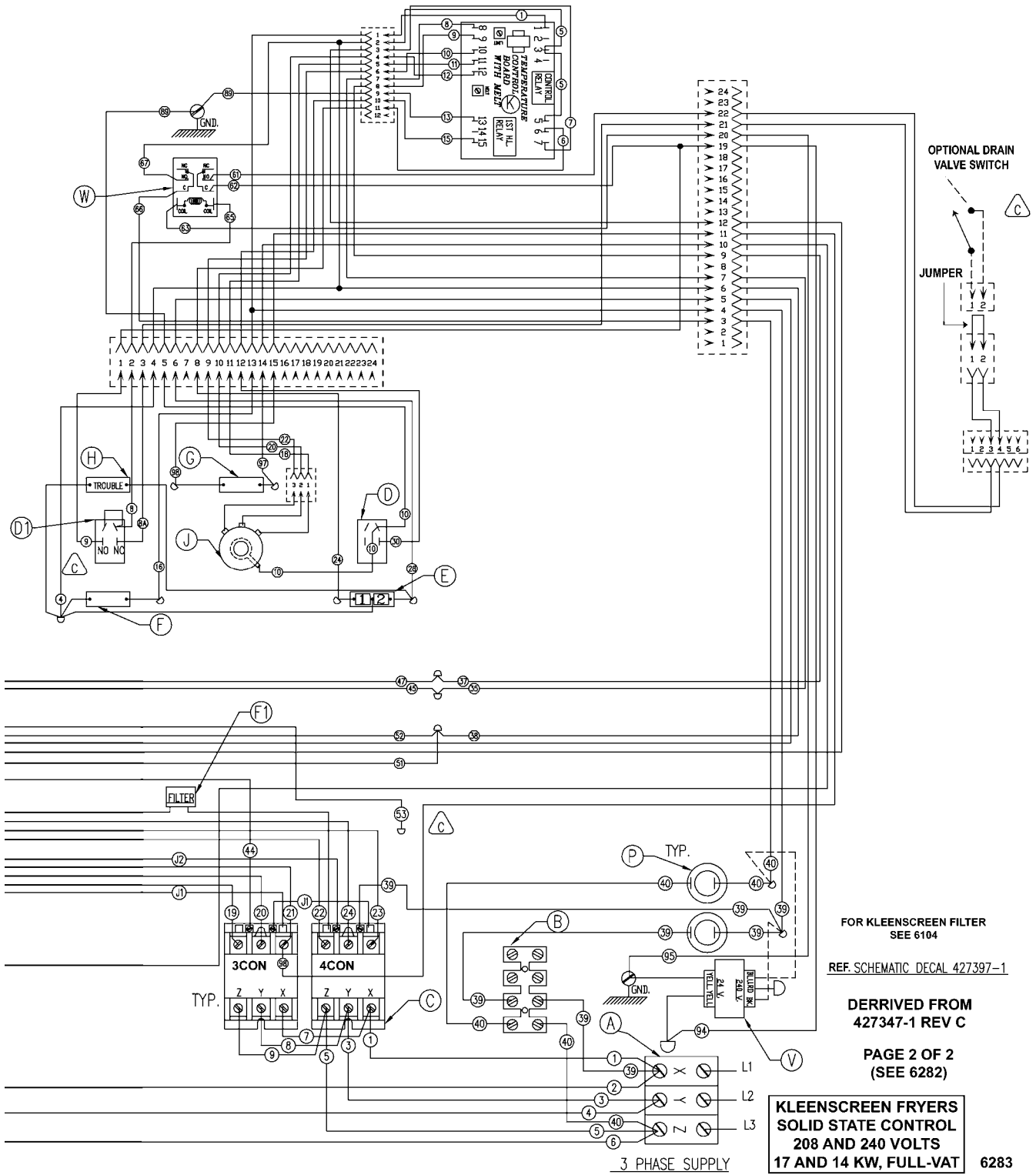

480 VOLT PHASE LOAD

TOTAL KW	KW/PHASE		
	X-Y	X-Z	Y-Z
24	8	8	8
21	7	7	7
17	5.66	5.66	5.66
14	4.66	4.66	4.66
	AMPS PER LINE		
	X	Y	Z
24	29	29	29
21	25	25	25
17	20	20	20
14	17	17	17

REQ.	REQ.	REQ.	REQ.	IT.	DESCRIPTION	FIN.
1	1	1	1	F1	FILTER ASSEMBLY SINGLE	-
1	1	1	1	Z	SWITCH, LIMIT TILT	-
1	1	1	1	W	RELAY DPDT 24V COIL	-
1	1	1	1	V	TRANSFORMER, 40VA 24V.	-
1	1	1	1	T	2ED HIGH LIMIT 435 F	-
2	-	-	-	R4	ELEMENT, FIREBAR 480V. 12 KW.	-
-	2	-	-	R3	ELEMENT, FIREBAR 480V. 10.5 KW.	-
-	-	2	-	R2	ELEMENT, FIREBAR 480V. 8.5 KW.	-
-	-	-	2	R1	ELEMENT, FIREBAR 480V. 7 KW.	-
2	2	2	2	P	FUSE & HOLDER	HOLDER FUSE
1	1	1	1	N	THERMISTOR PROBE	-
1	1	1	1	M	CORD, SUPPLY	-
1	1	1	1	L	RESISTOR, 300K 1/4W	-
1	1	1	1	K	TEMPERATURE CONTROL BOARD	-
1	1	1	1	J	POTENTIOMETER ASSEMBLY	-
1	1	1	1	H	LIGHT, INDICATOR *TROUBLE*	-
1	1	1	1	G	LIGHT, INDICATOR AMBER (HEAT)	-
1	1	1	1	F	LIGHT, INDICATOR RED (POWER)	-
1	1	1	1	E	LIGHT, INDICATOR (HIGH LIMIT)	-
1	1	1	1	DI	SWITCH, ROCKER DPDT MOM ON/OFF	-
2	2	2	2	D	SWITCH, ROCKER DPST (FRY/MELT)	-
4	4	4	4	C	CONTACTOR 3P 40A 120V COIL	-
1	1	1	1	B	STRIP-TERMINAL BARRIER	-
1	1	1	1	A	TERMINAL BLOCK	-

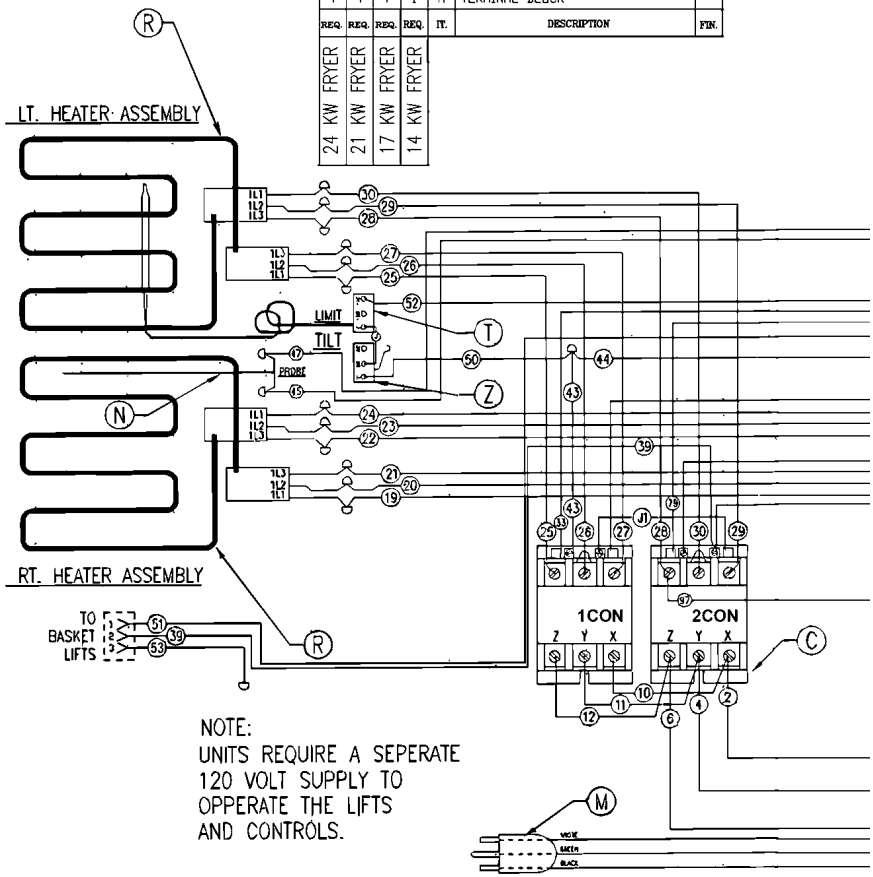

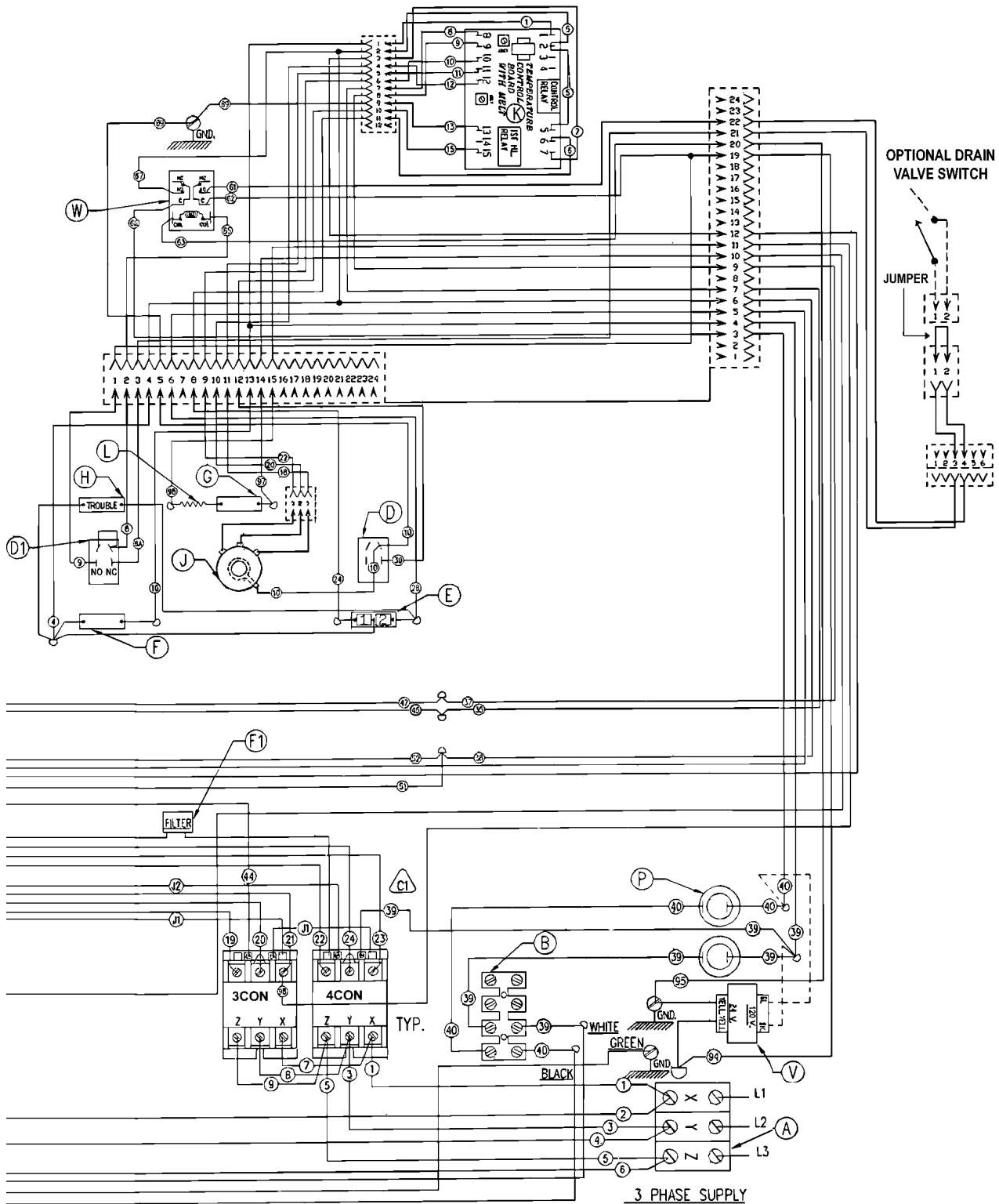

FOR KLEENSCREEN FILTER SEE 6104.

REF. SCHEMATIC DECAL 427399-2

DERIVED FROM 427351 REV. C

**KLEENSCREEN FRYERS  
SOLID STATE CONTROLS  
480 VOLTS ONLY  
24, 21, 17 AND 14 KW, FULL-VAT**

PAGE 2 OF 2  
(SEE 6284)

6285

2	2	F2	FILTER ASSEMBLY DOUBLE	-	-
2	2	Z	SWITCH, LIMIT TILT	-	-
2	2	W	RELAY DPDT 24V COIL	-	-
1	1	V	TRANSFORMER, 40 VA 24V.	240V.SYS	120V.SYS
2	2	T	2ED HIGH LIMIT 435 F	-	-
2	-	S	ELEMENT, FIREBAR 8.5KW	208 V.	240 V.
-	2	R	ELEMENT, FIREBAR 7KW	208 V.	240 V.
2	2	P	FUSE & HOLDER	HOLDER	FUSE
2	2	N	THERMISTOR PROBE	-	-
2	2	K	TEMPERATURE CONTROL BOARD	-	-
2	2	J	POTENTIOMETER ASSEMBLY	-	-
2	2	H	LIGHT, INDICATOR 'TROUBLE'	-	-
2	2	G	LIGHT, INDICATOR AMBER (HEAT)	-	-
2	2	F	LIGHT, INDICATOR RED (POWER)	-	-
2	2	E	LIGHT, INDICATOR (1 2) (HIGH LIMIT)	-	-
2	2	DI	SWITCH, ROCKER DPST MOM. CT/OFF	-	-
2	2	D	SWITCH, ROCKER DPST (FRY/MELT)	-	-
4	4	C	CONTACTOR 3P 40A 230V COIL	-	-
1	1	B	STRIP-TERMINAL BARRIER	-	-
1	1	A	TERMINAL BLOCK	-	-
REQ.	REQ.	IT.	DESCRIPTION		FIN.

17 KW FRYER	14 KW FRYER
-------------	-------------

TOTAL KW	KW/PHASE		
	X-Y	X-Z	Y-Z
17	5.6	5.6	5.6
14	4.6	4.6	4.6
AMPS PER LINE 208 VOLT			
	X	Y	Z
17	47	47	47
14	39	39	39
AMPS PER LINE 240 VOLT			
	X	Y	Z
17	41	41	41
14	34	34	34

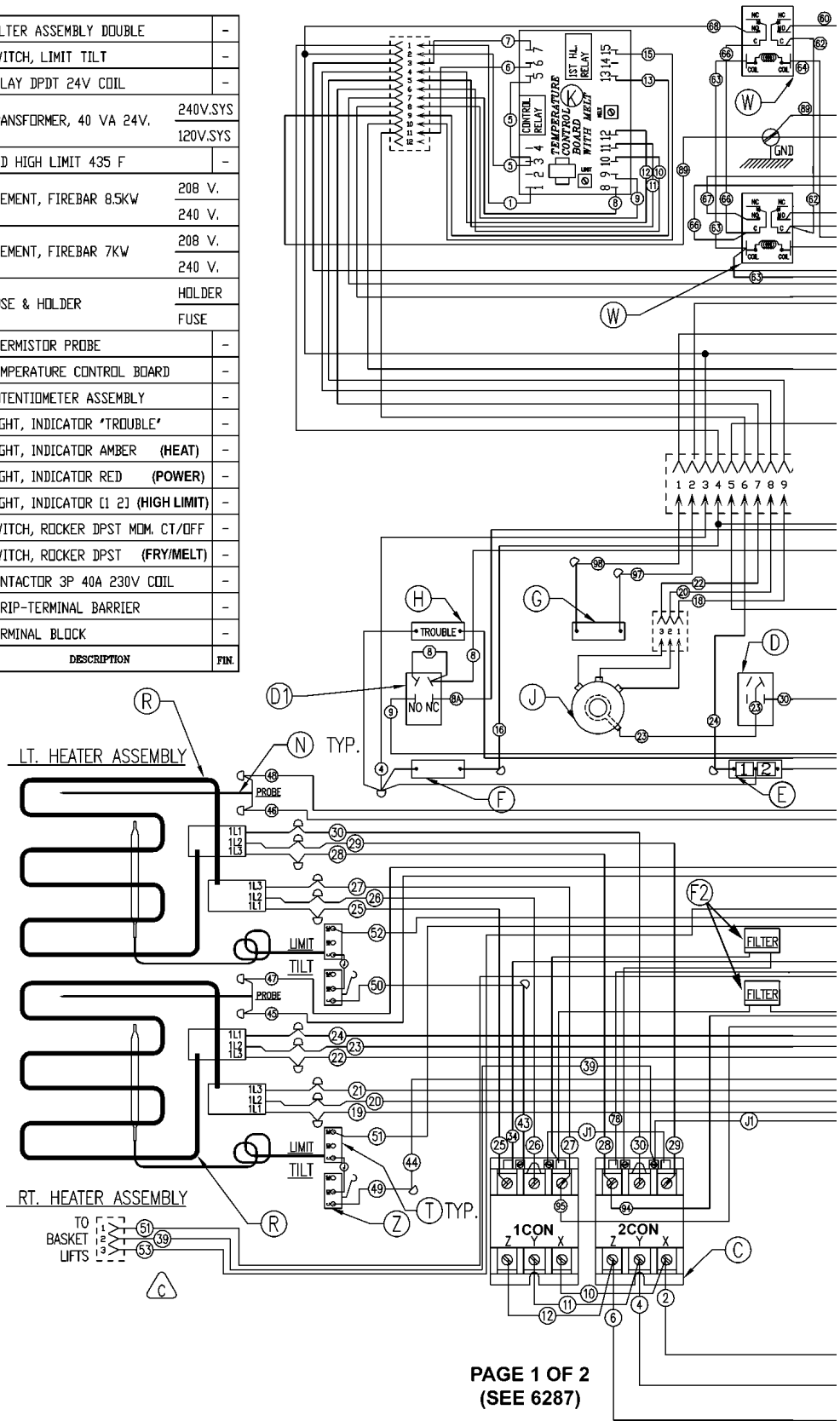

PAGE 1 OF 2  
(SEE 6287)

6286



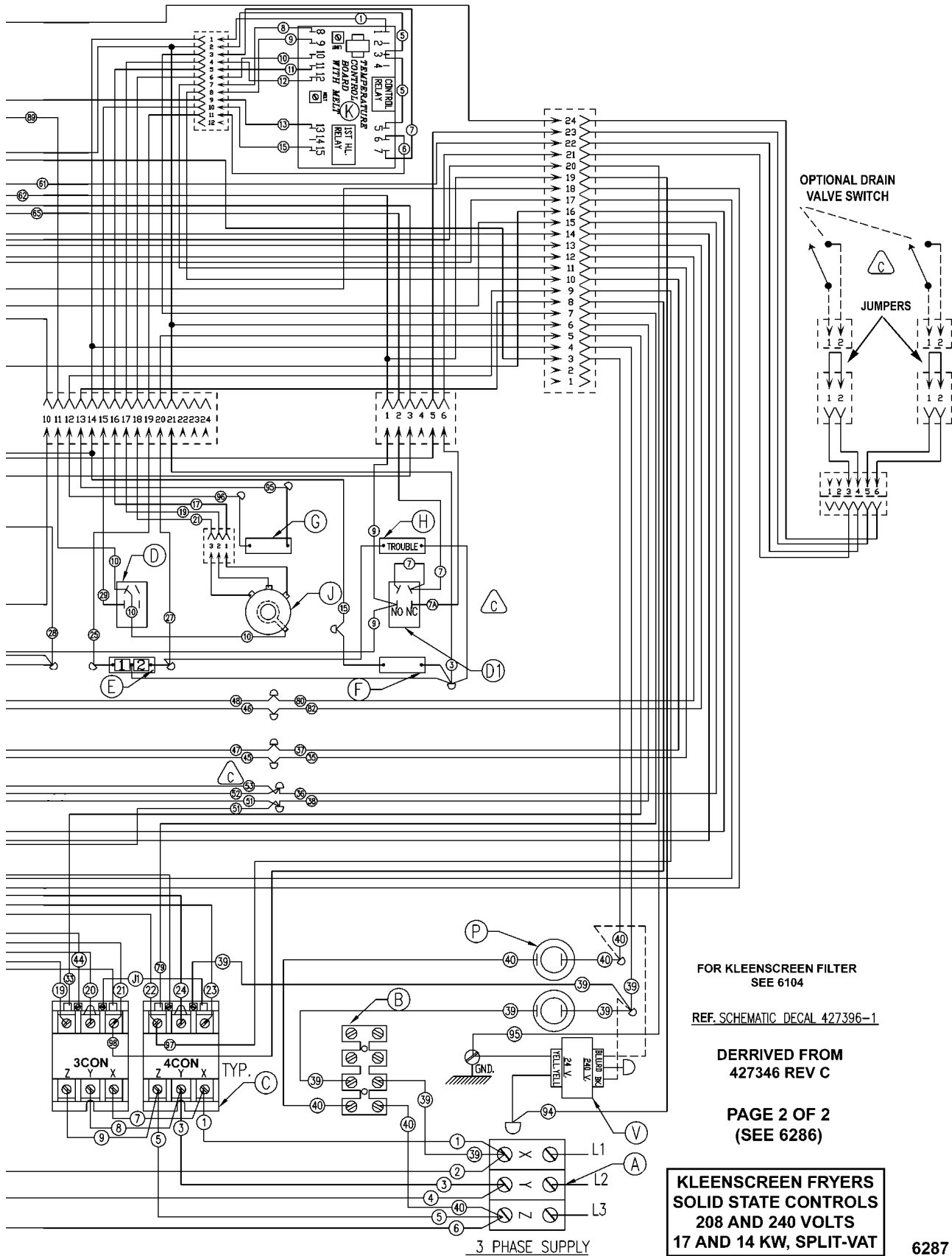

FOR KLEENSCREEN FILTER  
SEE 6104

REF. SCHEMATIC DECAL 427396-1

DERIVED FROM  
427346 REV C

PAGE 2 OF 2  
(SEE 6286)

**KLEENSCREEN FRYERS  
SOLID STATE CONTROLS  
208 AND 240 VOLTS  
17 AND 14 KW, SPLIT-VAT**

6287

2	F2	FILTER ASSEMBLY DOUBLE	-
2	Z	SWITCH, LIMIT TILT	-
2	W	RELAY DPDT 24V COIL	-
1	V	TRANSFORMER, 40 VA 24V.	240V.SYS 120V.SYS
2	T	2ED HIGH LIMIT 435 F	-
2	R	ELEMENT, FIREBAR 10.5KW	208 V. 240 V.
2	P	FUSE & HOLDER	HOLDER FUSE
2	N	THERMISTOR PROBE	-
2	M	CIRCUIT BREAKER 50A 3 POLE	-
2	K	TEMPERATURE CONTROL BOARD	-
2	J	POTENTIOMETER ASSEMBLY	-
2	H	LIGHT, INDICATOR 'TROUBLE'	-
2	G	LIGHT, INDICATOR AMBER	-
2	F	LIGHT, INDICATOR RED	(HEAT)
2	E	LIGHT, INDICATOR [1 2]	(POWER)
2	DI	SWITCH, ROCKER DPDT MOM ON/OFF (HIGH LIMIT)	-
2	D	SWITCH, ROCKER DPST	(FRY/MELT)
4	C	CONTACTOR 3P 40A 230V COIL	-
1	B	STRIP-TERMINAL BARRIER	-
1	A	TERMINAL BLOCK	-
REQ.	IT.	DESCRIPTION	FIN.

21 KW FRYER

208-240 VOLT PHASE LOAD

TOTAL KW	KW/PHASE		
	X-Y	X-Z	Y-Z
21	7	7	7
AMPS PER LINE 208 VOLT			
	X	Y	Z
21	58	58	58
AMPS PER LINE 240 VOLT			
	X	Y	Z
21	51	51	51

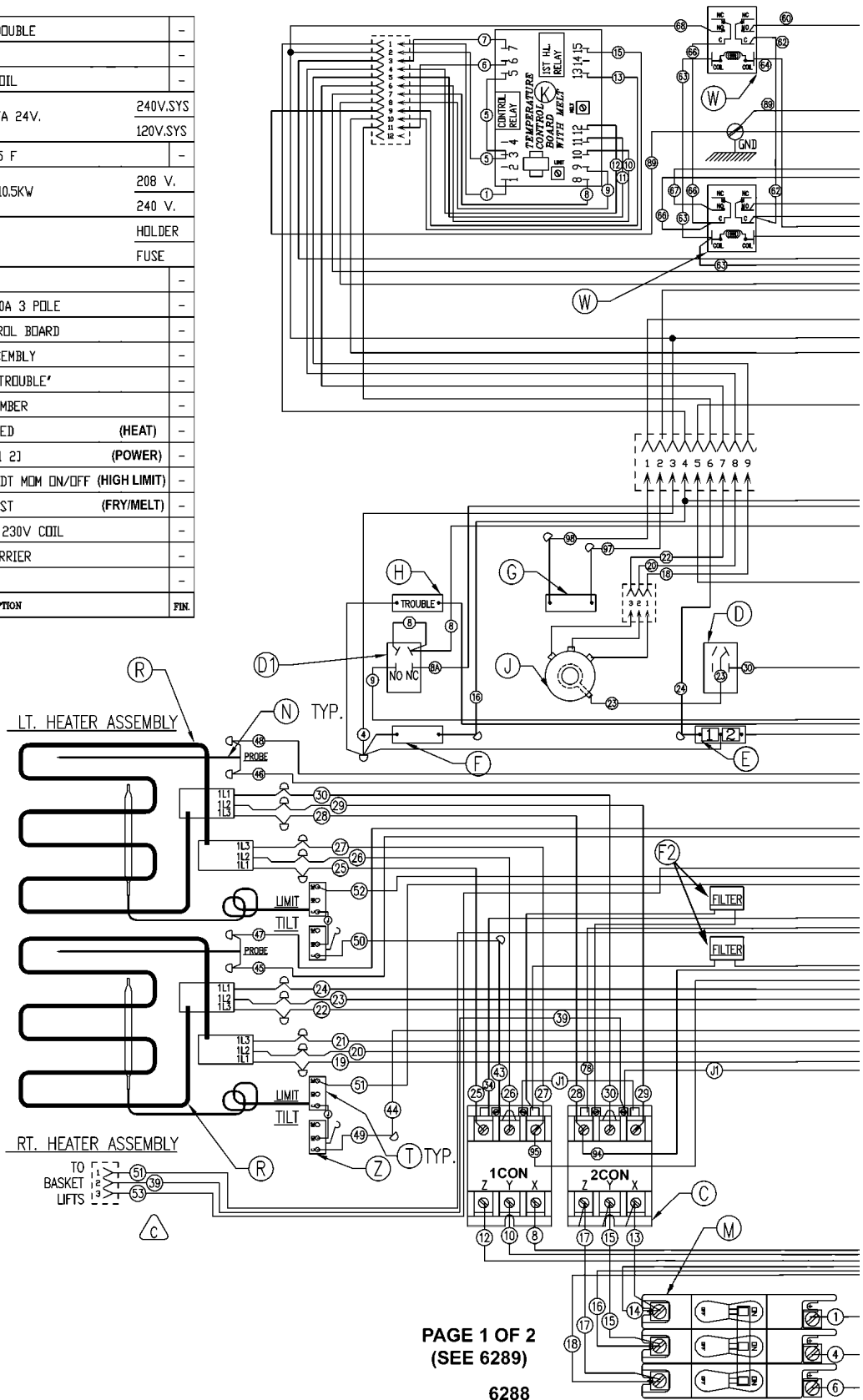

PAGE 1 OF 2  
(SEE 6289)  
6288

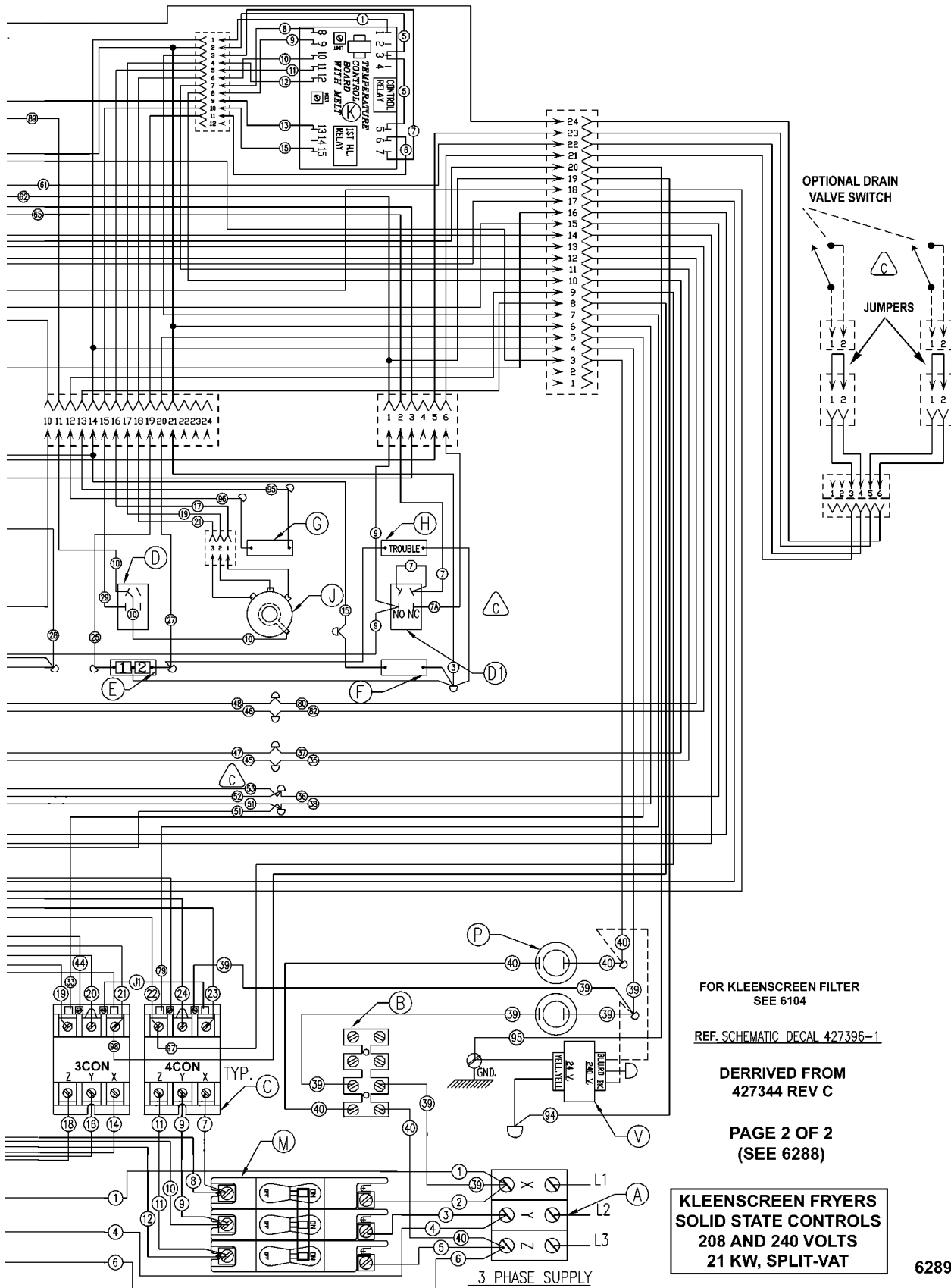

FOR KLEENSCREEN FILTER  
SEE 6104

REF. SCHEMATIC DECAL 427396-1

DERIVED FROM  
427344 REV C

PAGE 2 OF 2  
(SEE 6288)

**KLEENSCREEN FRYERS  
SOLID STATE CONTROLS  
208 AND 240 VOLTS  
21 KW, SPLIT-VAT**

6289

1	1	1	F2	FILTER ASSEMBLY DOUBLE	-
2	2	2	Z	SWITCH, LIMIT TILT	-
2	2	2	W	RELAY DPDT 24V COIL	-
1	1	1	V	TRANSFORMER, 40VA 24V.	-
2	2	2	T	2ED HIGH LIMIT 435 F	-
2	-	-	R3	ELEMENT, FIREBAR 480V. 10.5 KW.	-
-	2	-	R2	ELEMENT, FIREBAR 480V. 8.5 KW.	-
-	-	2	R1	ELEMENT, FIREBAR 480V. 7 KW.	-
2	2	2	P	FUSE & HOLDER	HOLDER FUSE
2	2	2	N	THERMISTOR PROBE	-
1	1	1	M	CORD, SUPPLY	-
2	2	2	L	RESISTOR, 300K 1/4W	-
2	2	2	K	TEMPERATURE CONTROL BOARD	-
2	2	2	J	POTENTIOMETER ASSEMBLY	-
2	2	2	H	LIGHT, INDICATOR 'TROUBLE'	-
2	2	2	G	LIGHT, INDICATOR AMBER (HEAT)	-
2	2	2	F	LIGHT, INDICATOR RED (POWER)	-
2	2	2	E	LIGHT, INDICATOR [ 2 ] (HIGH LIMIT)	-
4	4	4	D	SWITCH, ROCKER DPST (FRY/MELT)	-
4	4	4	C	CONTACTOR 3P 40A 120V COIL	-
1	1	1	B	STRIP-TERMINAL BARRIER	-
1	1	1	A	TERMINAL BLOCK	-
REQ.	REQ.	REQ.	IT.	DESCRIPTION	FIN.

21 KW FRYER	17 KW FRYER	14 KW FRYER
-------------	-------------	-------------

480 VOLT PHASE LOAD

TOTAL KW	KW/PHASE		
	X-Y	X-Z	Y-Z
21	7	7	7
17	5.66	5.66	5.66
14	4.66	4.66	4.66
AMPS PER LINE			
	X	Y	Z
21	25	25	25
17	20	20	20
14	17	17	17

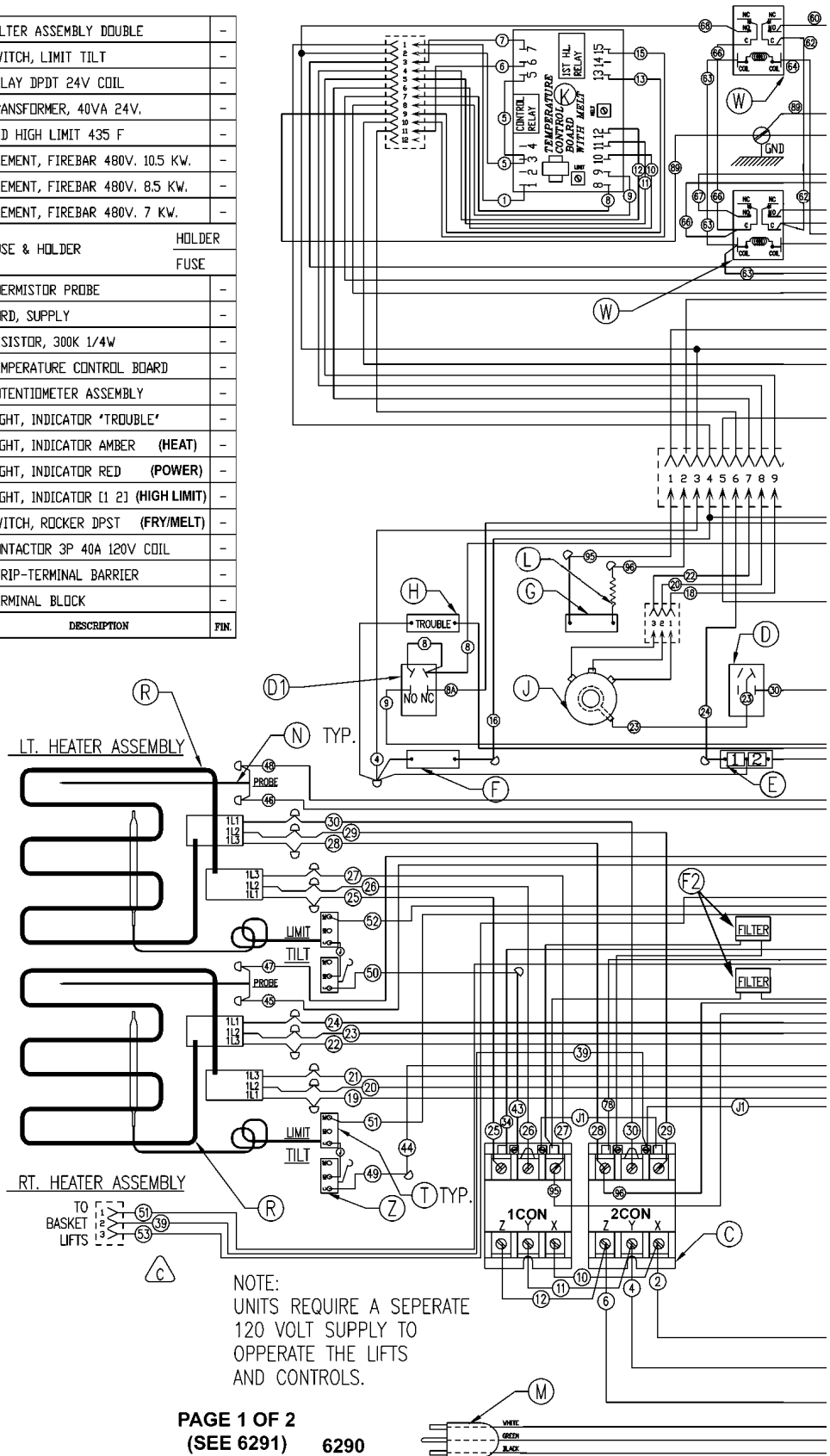

PAGE 1 OF 2  
(SEE 6291) 6290

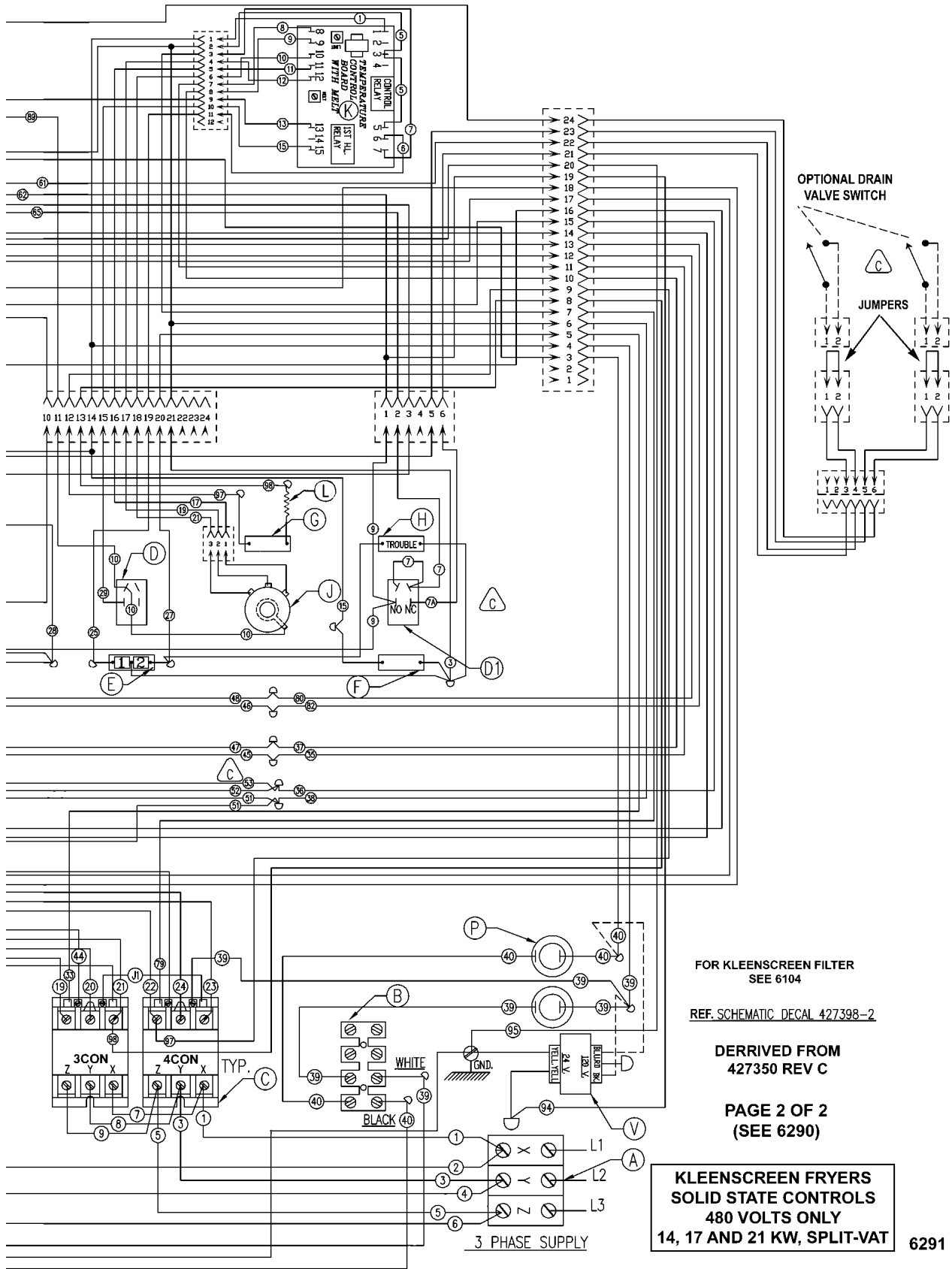

FOR KLEENSCREEN FILTER  
SEE 6104

REF. SCHEMATIC DECAL 427398-2

DERIVED FROM  
427350 REV C

PAGE 2 OF 2  
(SEE 6290)

**KLEENSCREEN FRYERS  
SOLID STATE CONTROLS  
480 VOLTS ONLY  
14, 17 AND 21 KW, SPLIT-VAT**

6291

1	1	F1	FILTER ASSEMBLY SINGLE	-
1	1	Z	SWITCH, LIMIT TILT	-
1	1	V	TRANSFORMER, 40 VA 24V.	240V.SYS 120V.SYS
1	1	T	2ED HIGH LIMIT 435 F	-
2	-	S	ELEMENT, FIREBAR 8.5KW	208 V. 240 V.
-	2	R	ELEMENT, FIREBAR 7KW	208 V. 240 V.
2	2	P	FUSE & HOLDER	HOLDER FUZE
1	1	N	THERMISTOR PROBE	-
1	1	K	COMPUTER CONTROL	RED BLACK
1	1	H	RELAY DPDT 240V COIL	-
1	1	G	RELAY, DPDT 24V COIL	-
1	1	F	TRANSFORMER 240-12V	-
1	1	E	BOARD, COMPUTER POWER SUPPLY	-
1	1	D	SWITCH, ROCKER DPST	-
4	4	C	CONTACTOR 3P 40A 230V COIL	-
1	1	B	STRIP-TERMINAL BARRIER	-
1	1	A	TERMINAL BLOCK	-
REQ.	REQ.	IT.	DESCRIPTION	FINL

208-240 VOLT PHASE LOAD

TOTAL KW	KW/PHASE		
	X-Y	X-Z	Y-Z
17	5.6	5.6	5.6
14	4.6	4.6	4.6
AMPS PER LINE 208 VOLT			
	X	Y	Z
17	47	47	47
14	39	39	39
AMPS PER LINE 240 VOLT			
	X	Y	Z
17	41	41	41
14	34	34	34

17 KW FRYER  
14 KW FRYER

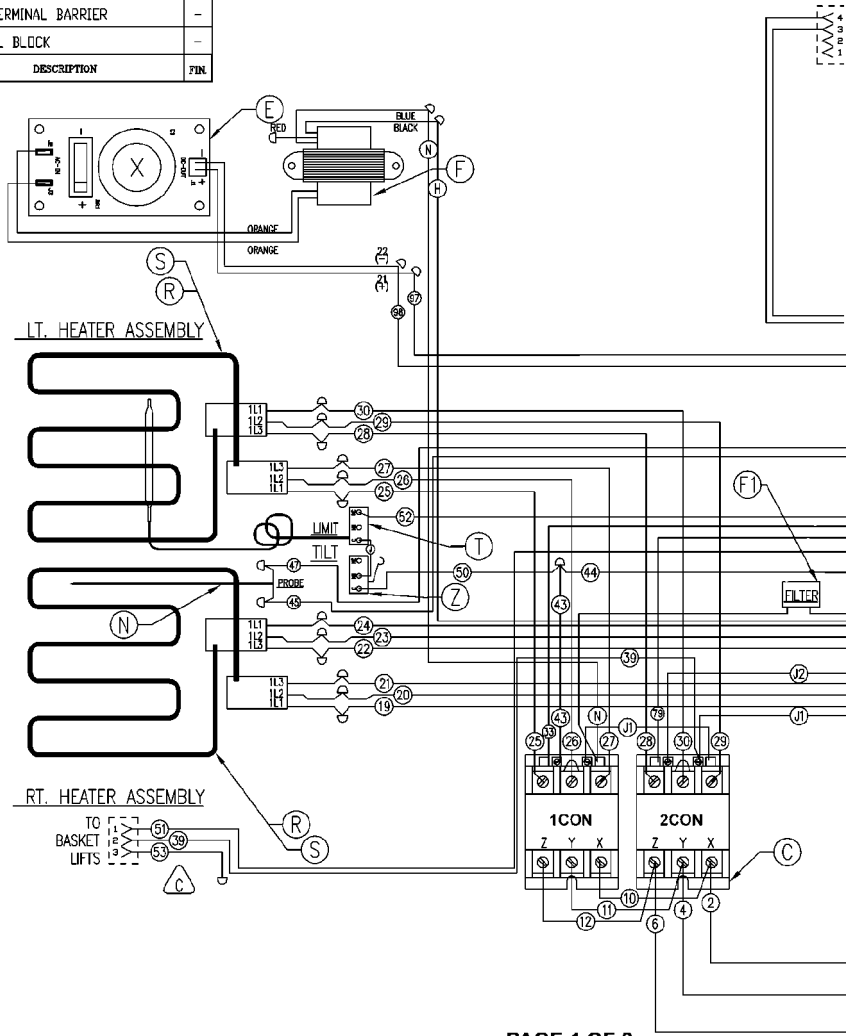

PAGE 1 OF 2  
(SEE 6293)

6292

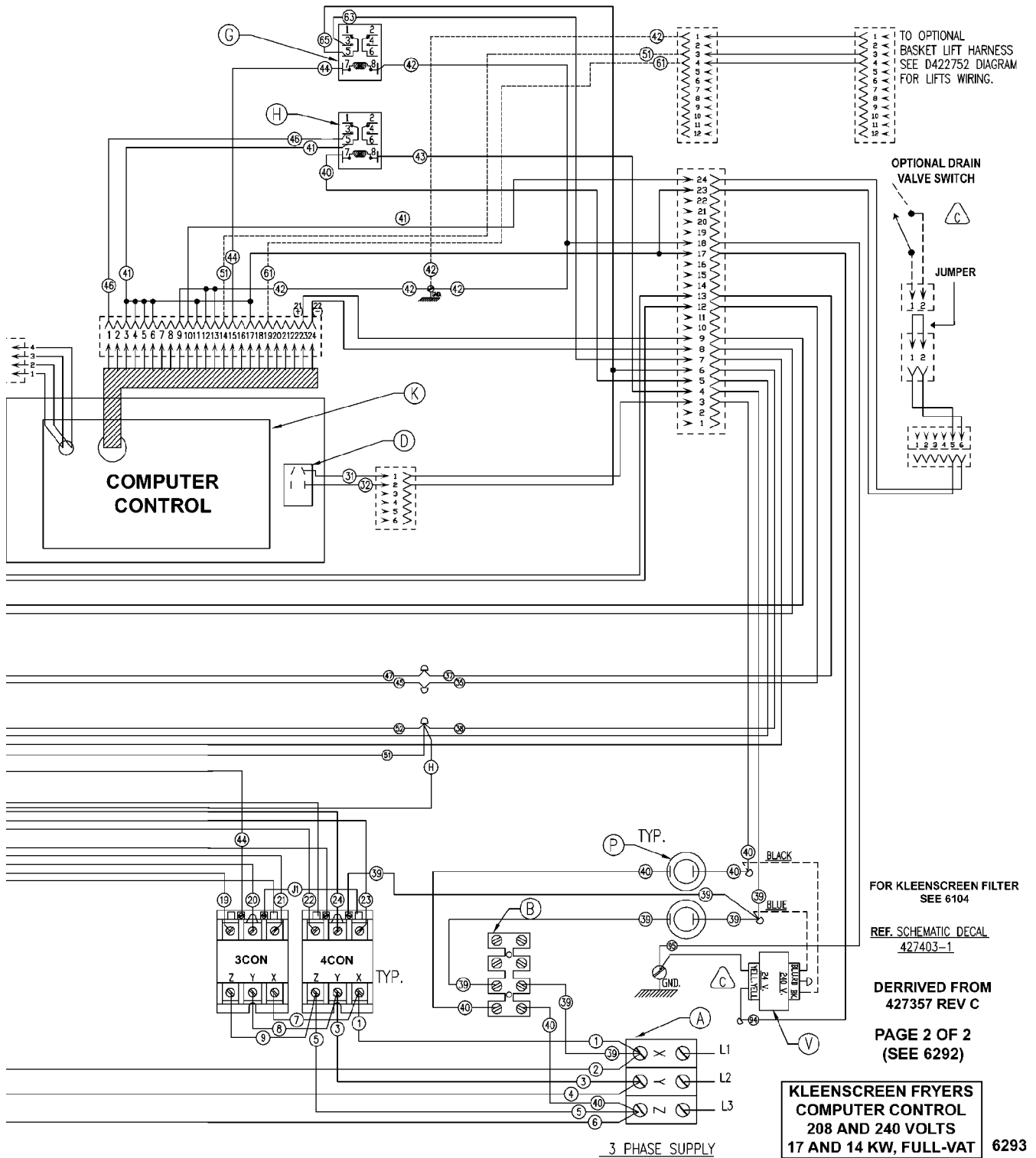

1	1	V	TRANSFORMER, 40 VA 24V.	240V.SYS 120V.SYS	-
1	1	Z	SWITCH, LIMIT TILT		-
*1	*1	X	CORD, SUPPLY - FILTER		-
*1	*1	W	RELAY, SPDT 24V. COIL		-
1	1	F1	FILTER ASSEMBLY SINGLE		-
1	1	U	HARNES-CABLE ASSEMBLY		-
1	1	T	2ED HIGH LIMIT 435 F		-
2	-	S	ELEMENT, FIREBAR 12KW	208 V. 240 V.	
-	2	R	ELEMENT, FIREBAR 10.5KW	208 V. 240 V.	
2	2	P	FUSE & HOLDER	HOLDER FUSE	
-	1	N	THERMISTOR PROBE		-
1	-	N	THERMISTOR PROBE		-
2	2	M	CIRCUIT BREAKER 50A 3 POLE		-
1	1	K	COMPUTER CONTROL	RED BLACK	
1	1	H	RELAY DPDT 240V COIL		-
1	1	G	RELAY, DPDT 24V COIL		-
1	1	F	TRANSFORMER 240-12V		-
1	1	E	BOARD, COMPUTER POWER SUPPLY		-
1	1	D	SWITCH, ROCKER DPST		-
4	4	C	CONTACTOR 3P 40A 230V COIL		-
1	1	B	STRIP-TERMINAL BARRIER		-
1	1	A	TERMINAL BLOCK		-
REQ.	REQ.	IT.	DESCRIPTION		FIN.

24 KW FRYER	21 KW FRYER
-------------	-------------

208-240 VOLT PHASE LOAD			
TOTAL KW	KW/PHASE		
	X-Y	X-Z	Y-Z
24	8	8	8
21	7	7	7
AMPS PER LINE 208 VOLT			
	X	Y	Z
24	67	67	67
21	58	58	58
AMPS PER LINE 240 VOLT			
	X	Y	Z
24	58	58	58
21	51	51	51

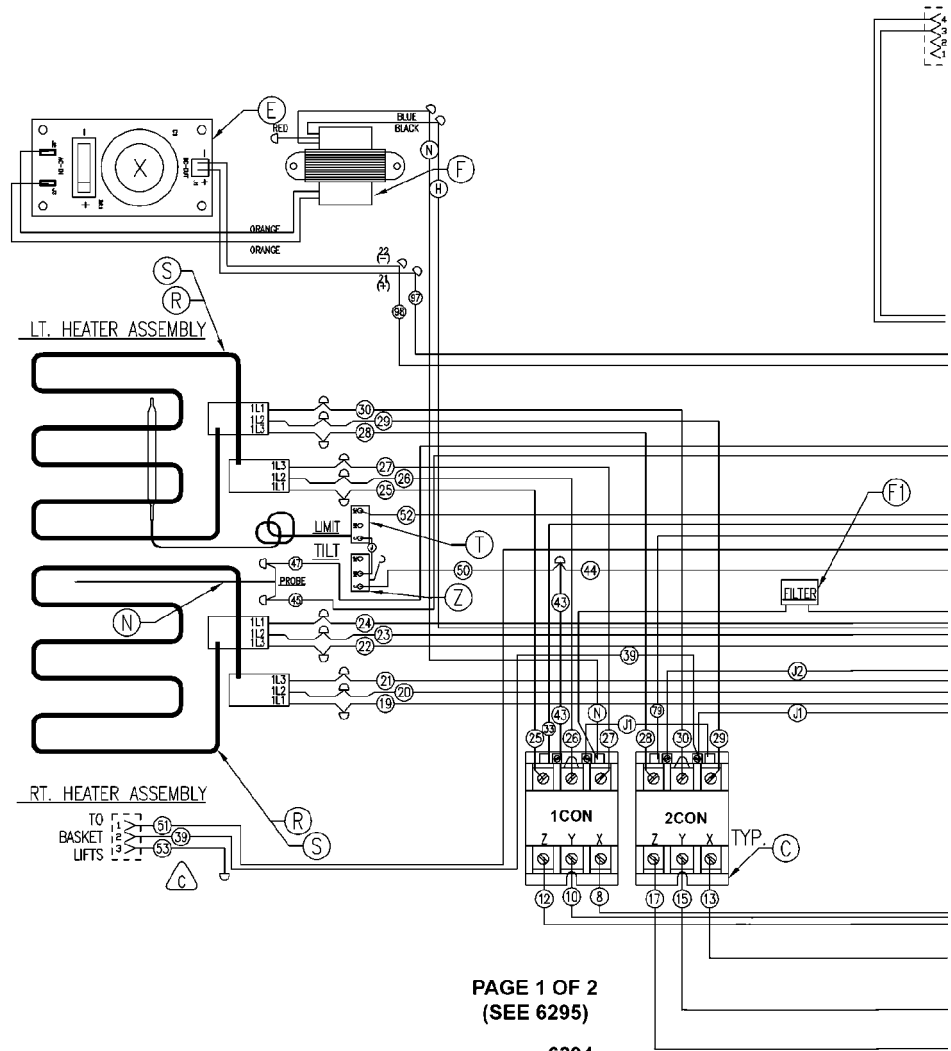

PAGE 1 OF 2  
(SEE 6295)

6294



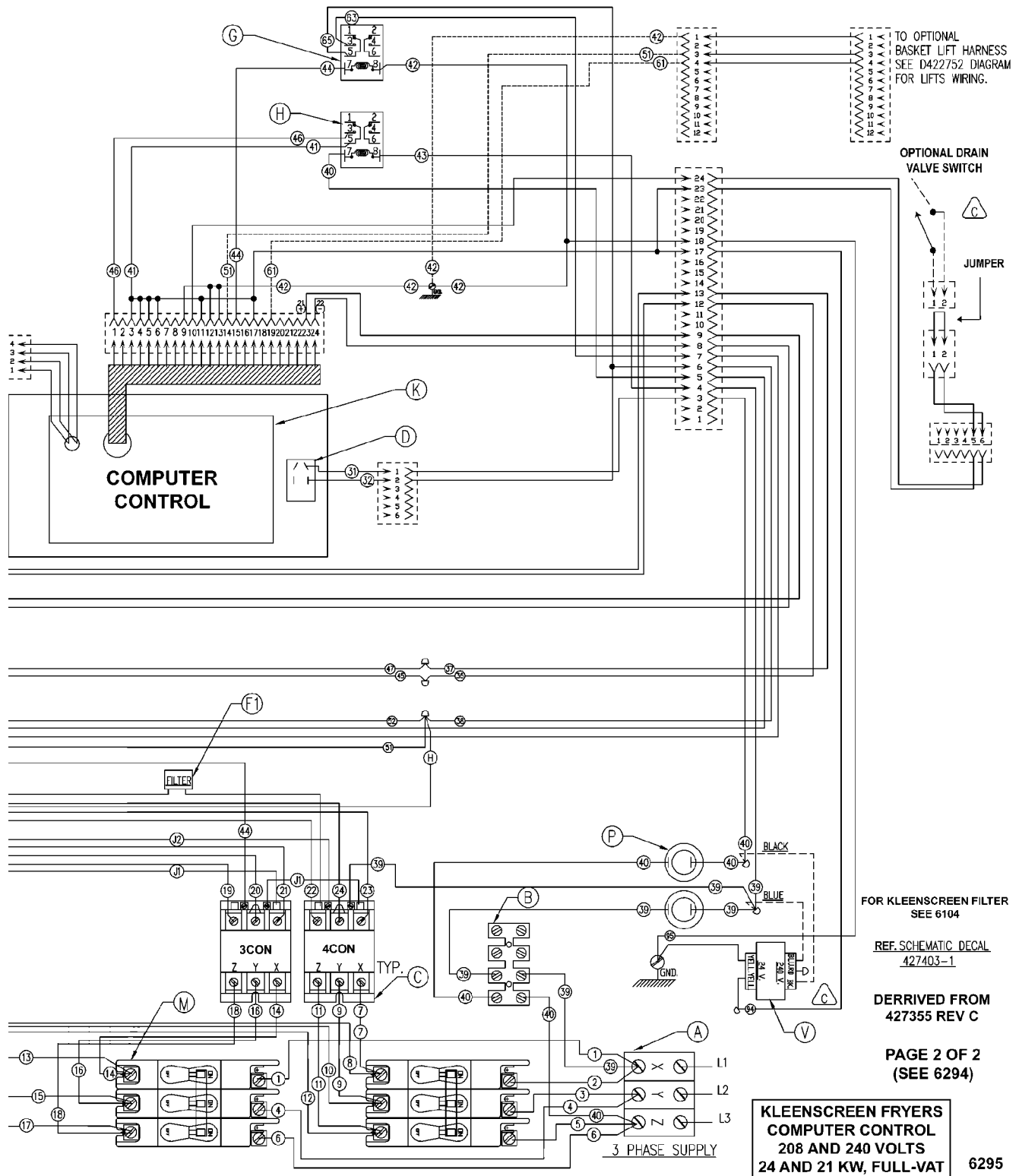

1	1	1	1	F1	FILTER ASSEMBLY SINGLE	-
1	1	1	1	Z	SWITCH, LIMIT TILT	-
1	1	1	1	V	TRANSFORMER, 40VA 120/24VAC	-
1	1	1	1	T	ZED HIGH LIMIT 435 F	-
2	-	-	-	R3	ELEMENT, FIREBAR 480V. 12 KW.	-
-	2	-	-	R3	ELEMENT, FIREBAR 480V. 10.5 KW.	-
-	-	2	-	R2	ELEMENT, FIREBAR 480V. 8.5 KW.	-
-	-	-	2	R1	ELEMENT, FIREBAR 480V. 7 KW.	-
2	2	2	2	P	FUSE & HOLDER	HOLDER FUSE
1	1	1	1	M	CORD, SUPPLY	-
1	-	-	-	N	THERMISTOR PROBE	-
-	1	1	1	N	THERMISTOR PROBE	-
1	1	1	1	K	COMPUTER CONTROL	RED BLACK
1	1	1	1	H	RELAY DPDT 120V COIL	-
1	1	1	1	G	RELAY, DPDT 24V COIL	-
1	1	1	1	F	TRANSFORMER 120-12V	-
1	1	1	1	E	BOARD, COMPUTER POWER SUPPLY	-
1	1	1	1	D	SWITCH, ROCKER DPST	-
4	4	4	4	C	CONTACTOR 3P 40A 120V COIL	-
1	1	1	1	B	STRIP-TERMINAL BARRIER	-
1	1	1	1	A	TERMINAL BLOCK	-
REQ.	REQ.	REQ.	REQ.	IT.	DESCRIPTION	FIN.

24 KW FRYER	21 KW FRYER	17 KW FRYER	14 KW FRYER
-------------	-------------	-------------	-------------

480 VOLT PHASE LOAD

TOTAL KW	KW/PHASE		
	X-Y	X-Z	Y-Z
24	8	8	8
21	7	7	7
17	5.66	5.66	5.66
14	4.66	4.66	4.66
AMPS PER LINE			
	X	Y	Z
24	29	29	29
21	25	25	25
17	20	20	20
14	17	17	17

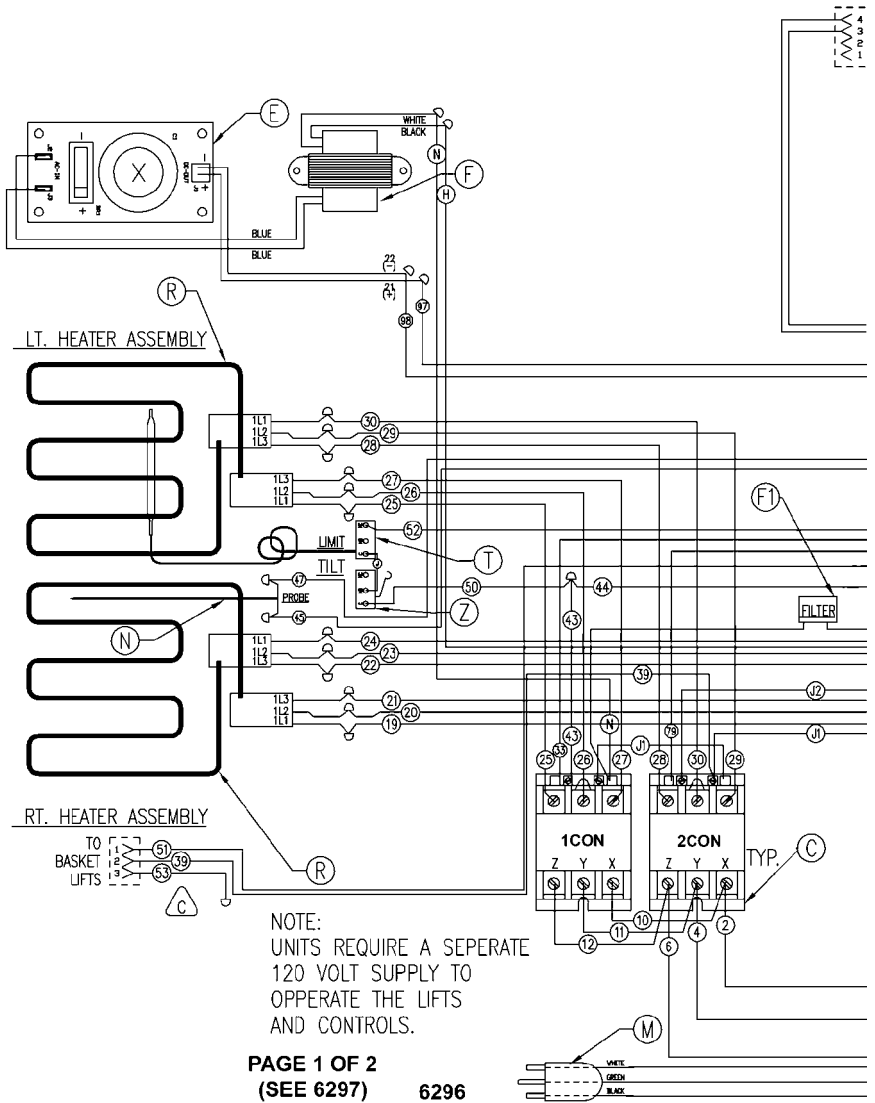

PAGE 1 OF 2  
(SEE 6297) 6296

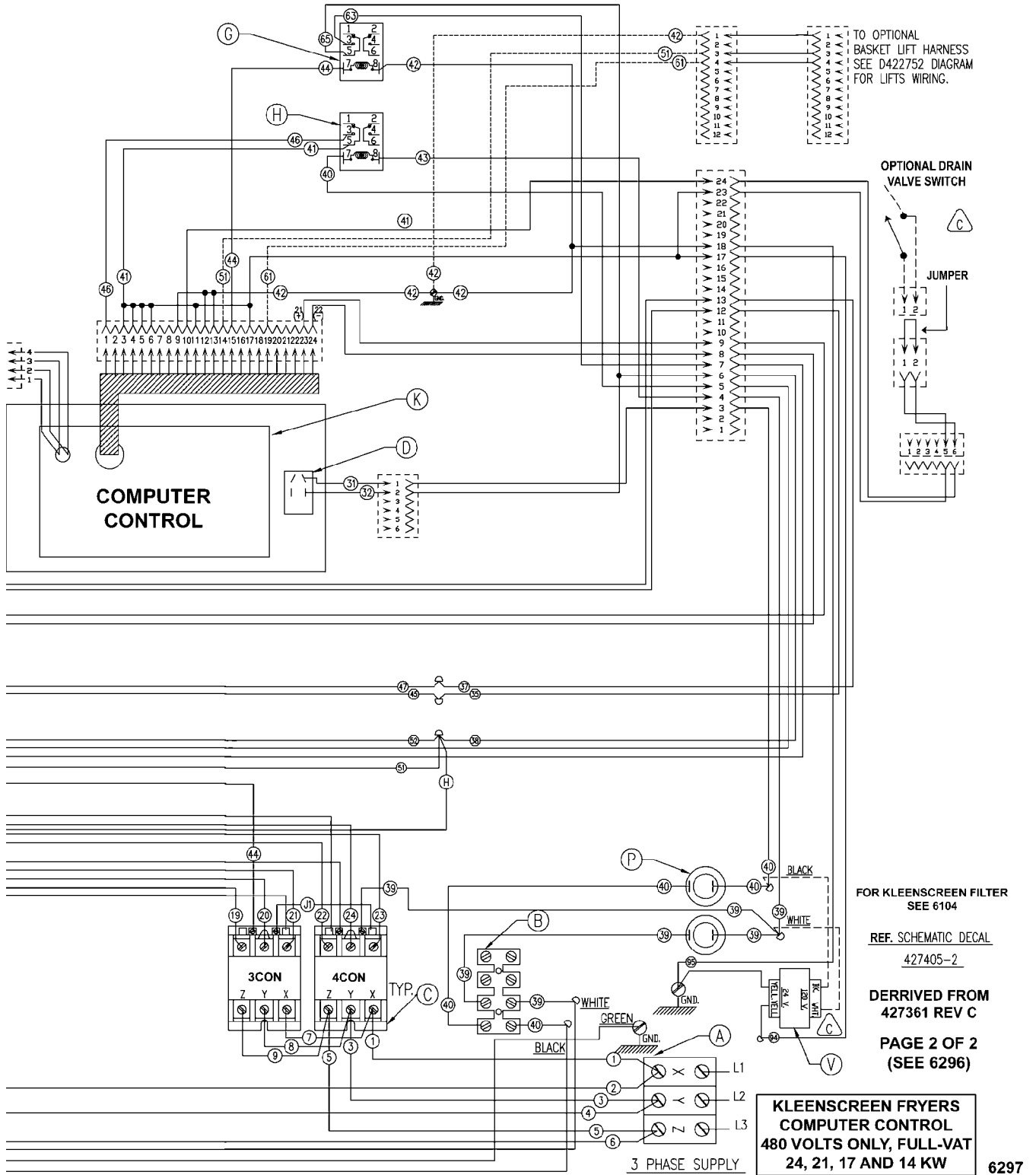

1	1	F2	FILTER ASSEMBLY DOUBLE	-
2	2	Z	SWITCH, LIMIT TILT	-
1	1	V	TRANSFORMER, 40 VA 24V.	240V.SYS 120V.SYS
2	2	T	2ED HIGH LIMIT 435 F	-
2	-	S	ELEMENT, FIREBAR 6.5KW	208 V. 240 V.
-	2	R	ELEMENT, FIREBAR 7KW	208 V. 240 V.
2	2	P	FUSE & HOLDER	HOLDER FUSE
2	2	N	THERMISTOR PROBE	-
1	1	K	COMPUTER CONTROL	RED BLACK
2	2	H	RELAY DPDT 240V COIL	-
2	2	G	RELAY, DPDT 24V COIL	-
1	1	F	TRANSFORMER 240-12V	-
1	1	E	BOARD, COMPUTER POWER SUPPLY	-
2	2	D	SWITCH, ROCKER DPST	-
4	4	C	CONTACTOR 3P 40A 230V COIL	-
1	1	B	STRIP-TERMINAL BARRIER	-
1	1	A	TERMINAL BLOCK	-
REQ.	REQ.	IT.	DESCRIPTION	FIN.

17 KW FRYER  
14 KW FRYER

208-240 VOLT PHASE LOAD

TOTAL KW	KW/PHASE		
	X-Y	X-Z	Y-Z
17	5.6	5.6	5.6
14	4.6	4.6	4.6
AMPS PER LINE 208 VOLT			
	X	Y	Z
17	47	47	47
14	39	39	39
AMPS PER LINE 240 VOLT			
	X	Y	Z
17	41	41	41
14	34	34	34

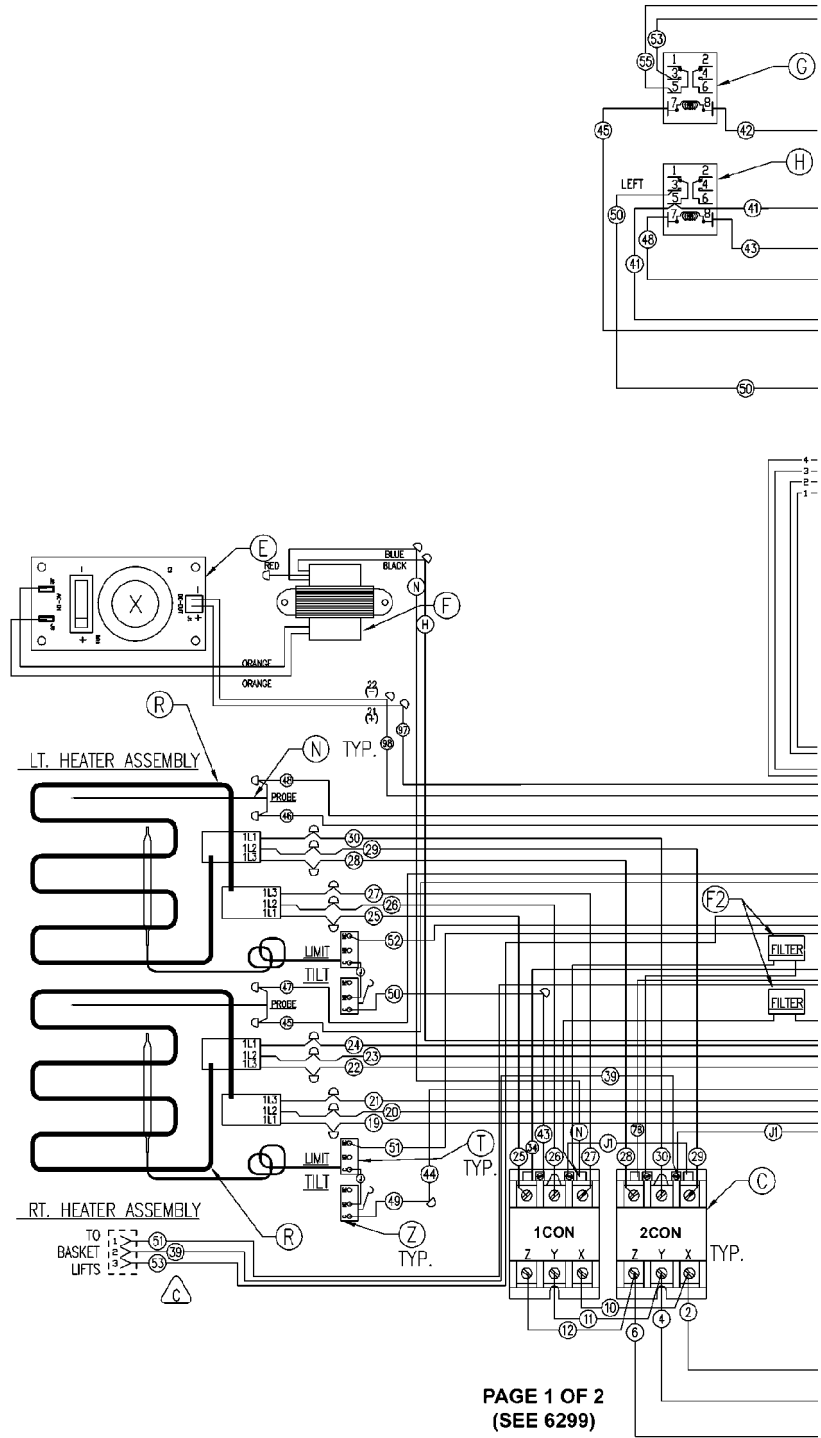

PAGE 1 OF 2  
(SEE 6299)

6298

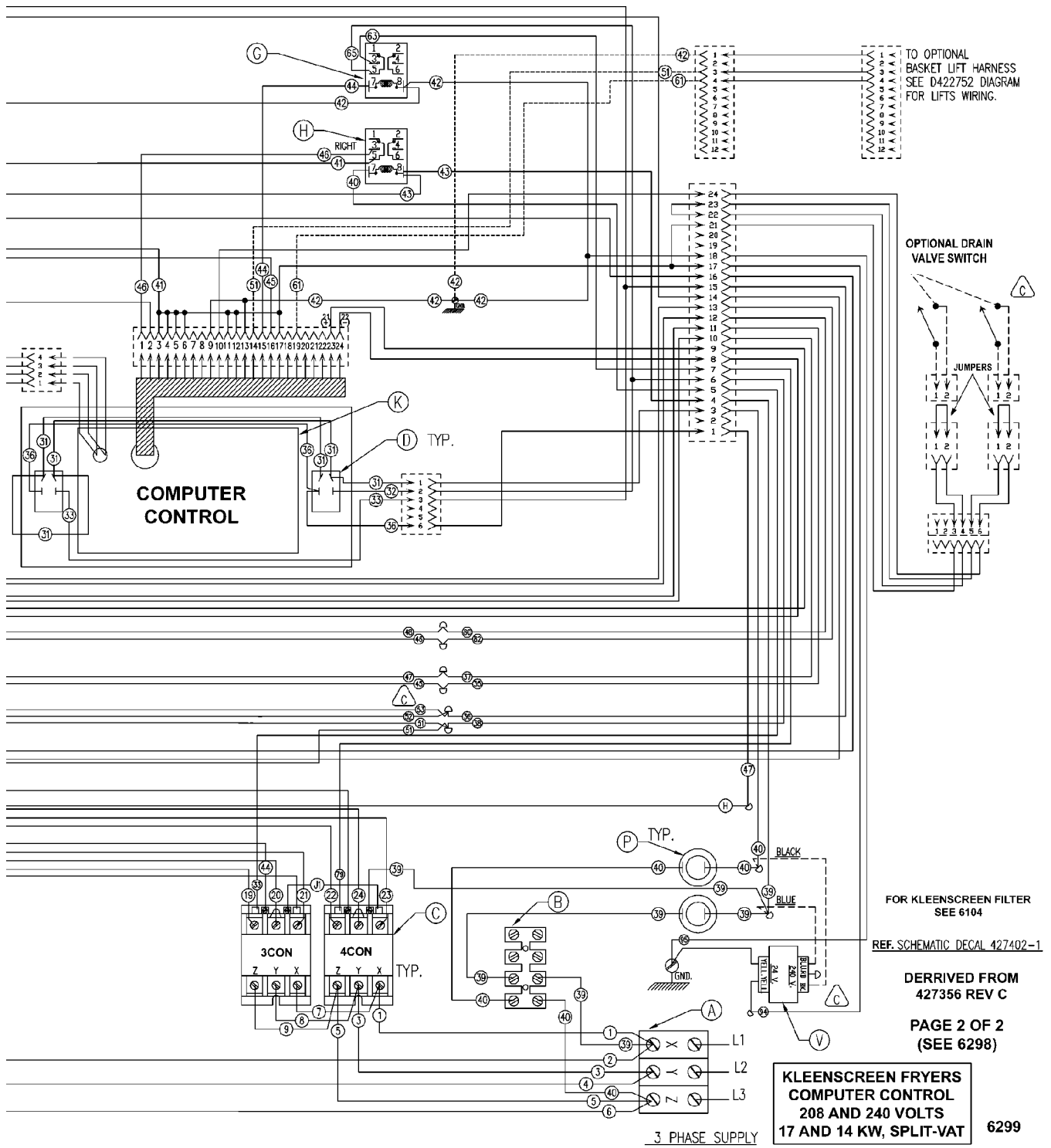

2	F2	FILTER ASSEMBLY DOUBLE	-
2	Z	SWITCH, LIMIT TILT	-
1	V	TRANSFORMER, 40 VA 24V.	240V.SYS 120V.SYS
2	I	2ED HIGH LIMIT 435 F	-
2	R	ELEMENT, FIREBAR 10.5KW	208 V. 240 V.
2	P	FUSE & HOLDER	HOLDER FUSE
2	N	THERMISTOR PROBE	-
2	M	CIRCUIT BREAKER 50A 3 POLE	-
1	K	COMPUTER CONTROL	RED BLACK
2	H	RELAY DPDT 240V COIL	-
2	G	RELAY, DPDT 24V COIL	-
1	F	TRANSFORMER 240-12V	-
1	E	BOARD, COMPUTER POWER SUPPLY	-
2	D	SWITCH, ROCKER DPST	-
4	C	CONTACTOR 3P 40A 230V COIL	-
1	B	STRIP-TERMINAL BARRIER	-
1	A	TERMINAL BLOCK	-
REQ.	REQ.	PT.	FIN.

21 KW FRYER

208-240 VOLT PHASE LOAD

TOTAL KW	KW/PHASE		
	X-Y	X-Z	Y-Z
21	7	7	7
AMPS PER LINE 208 VOLT			
	X	Y	Z
21	58	58	58
AMPS PER LINE 240 VOLT			
	X	Y	Z
21	51	51	51

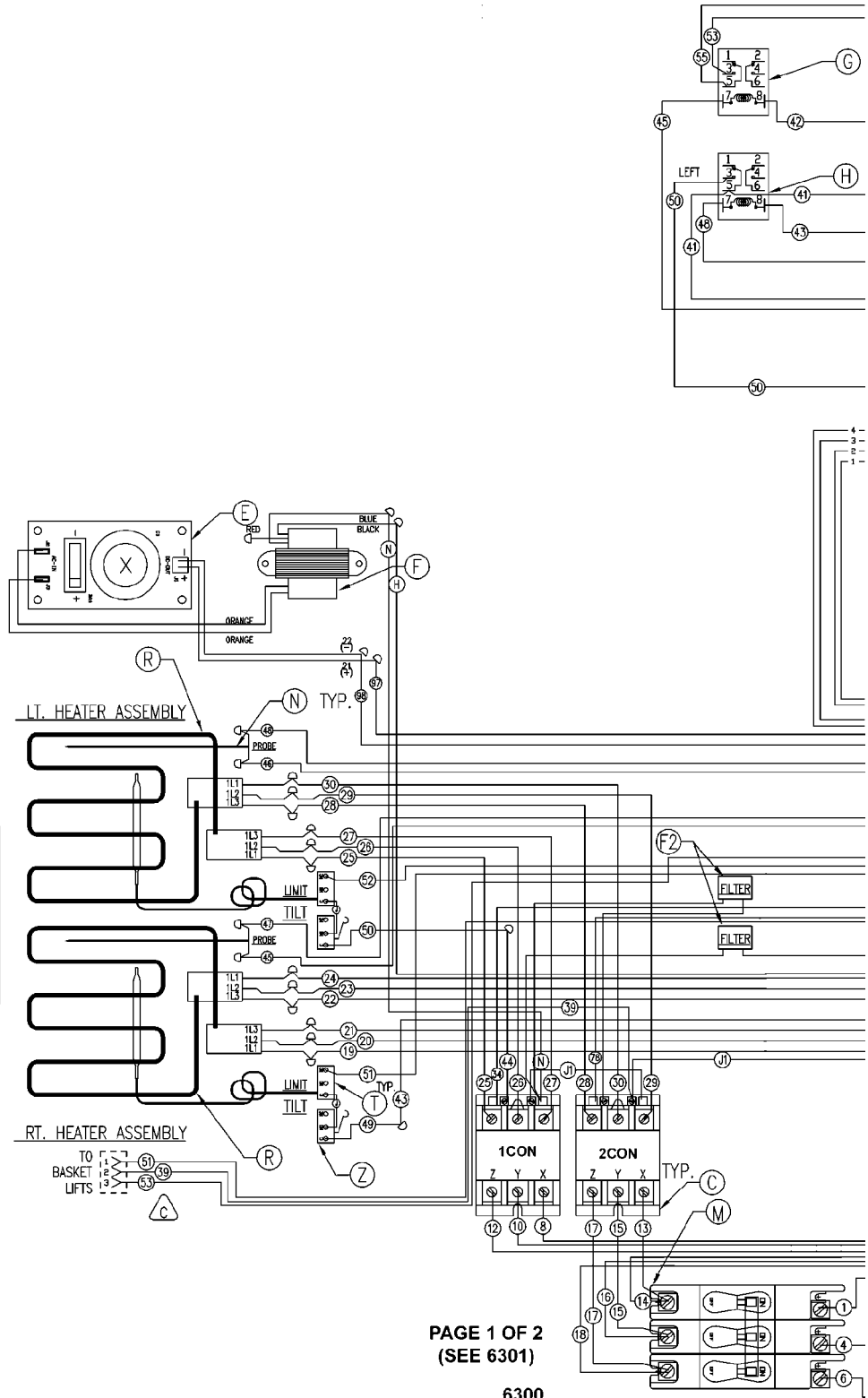

PAGE 1 OF 2  
(SEE 6301)

6300

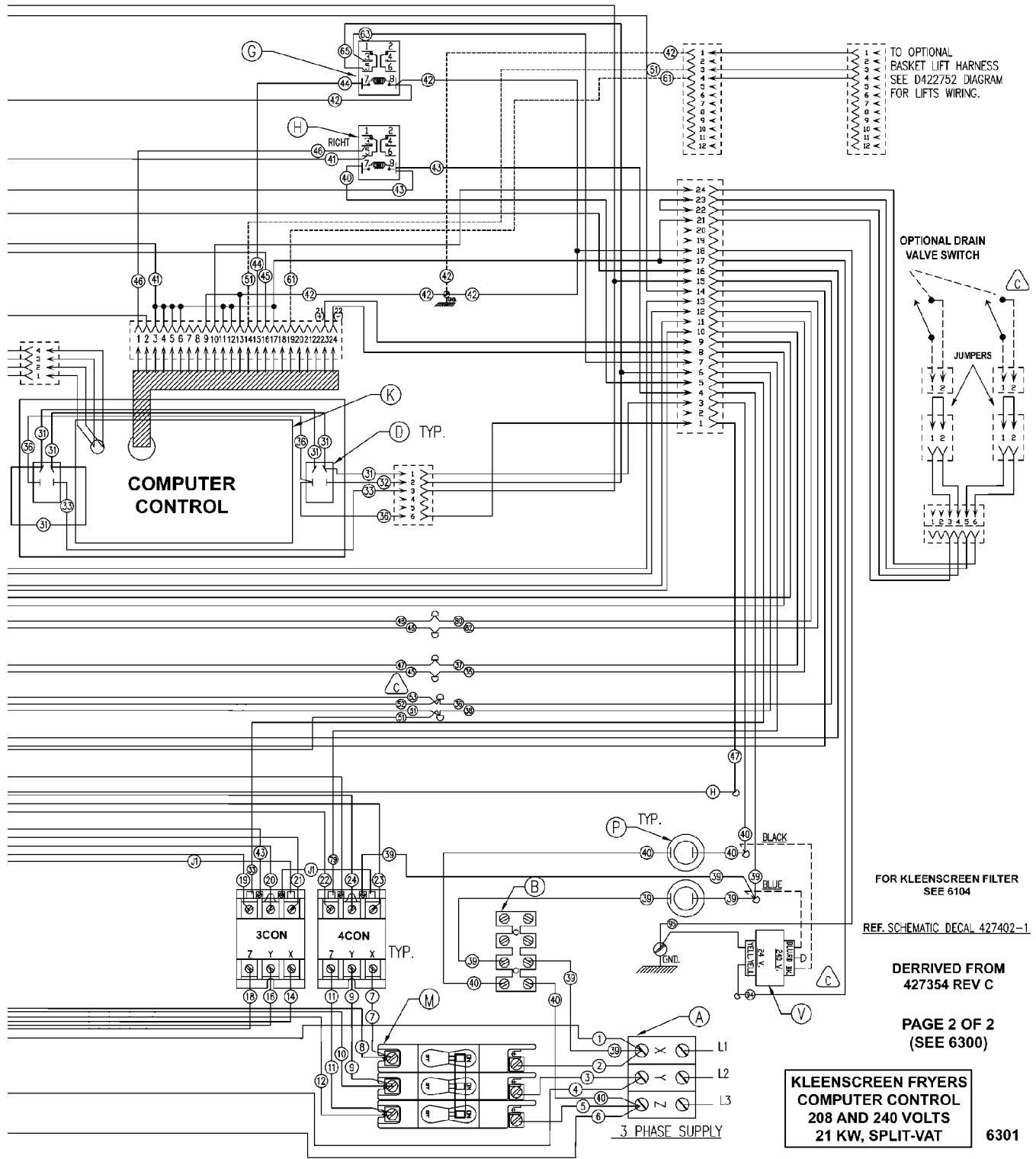

2	2	2	F2	FILTER ASSEMBLY DOUBLE	-
2	2	2	Z	SWITCH, LIMIT TILT	-
1	1	1	V	TRANSFORMER, 40VA 120/24VAC	-
2	2	2	T	2ED HIGH LIMIT 435 F	-
-	-	-	R3	ELEMENT, FIREBAR 480V. 10.5 KW.	-
-	-	-	R2	ELEMENT, FIREBAR 480V. 8.5 KW.	-
-	-	-	R1	ELEMENT, FIREBAR 480V. 7 KW.	-
2	2	2	P	FUSE & HOLDER	HOLDER FUSE
1	1	1	M	CORD, SUPPLY	-
2	2	2	N	THERMISTOR PROBE	-
1	1	1	K	COMPUTER CONTROL	RED BLACK
2	2	2	H	RELAY DPDT 120V COIL	-
2	2	2	G	RELAY, DPDT 24V COIL	-
1	1	1	F	TRANSFORMER 120-12V	-
1	1	1	E	BOARD, COMPUTER POWER SUPPLY	-
2	2	2	D	SWITCH, ROCKER DPST	-
4	4	4	C	CONTACTOR 3P 40A 120V COIL	-
1	1	1	B	STRIP-TERMINAL BARRIER	-
1	1	1	A	TERMINAL BLOCK	-
REQ.	REQ.	REQ.	QTY.	DESCRIPTION	FIN.
21 KW FRYER	17 KW FRYER	14 KW FRYER			

480 VOLT PHASE LOAD

TOTAL KW	KW/PHASE		
	X-Y	X-Z	Y-Z
21	7	7	7
17	5.66	5.66	5.66
14	4.66	4.66	4.66
AMPS PER LINE			
	X	Y	Z
21	25	25	25
17	20	20	20
14	17	17	17

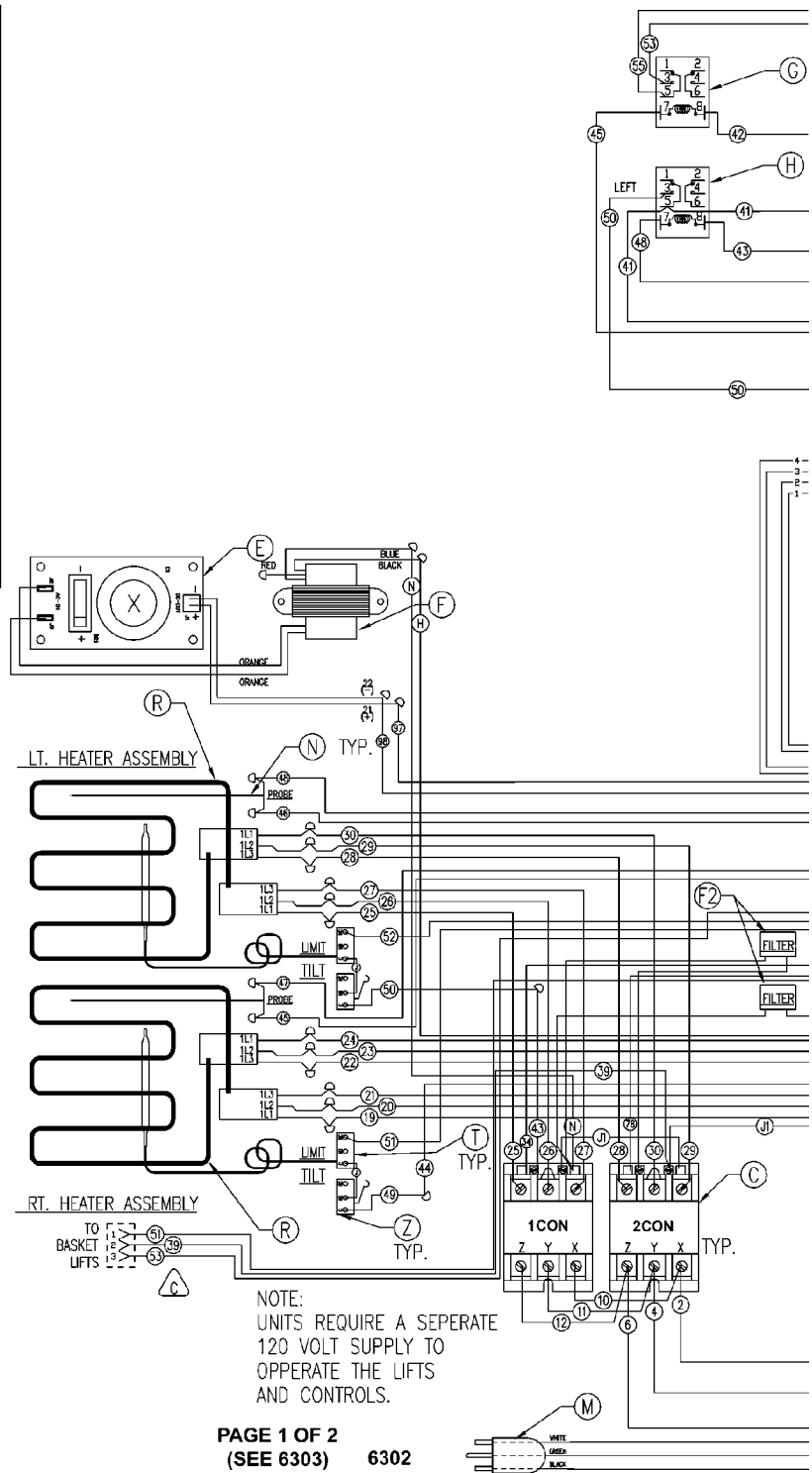



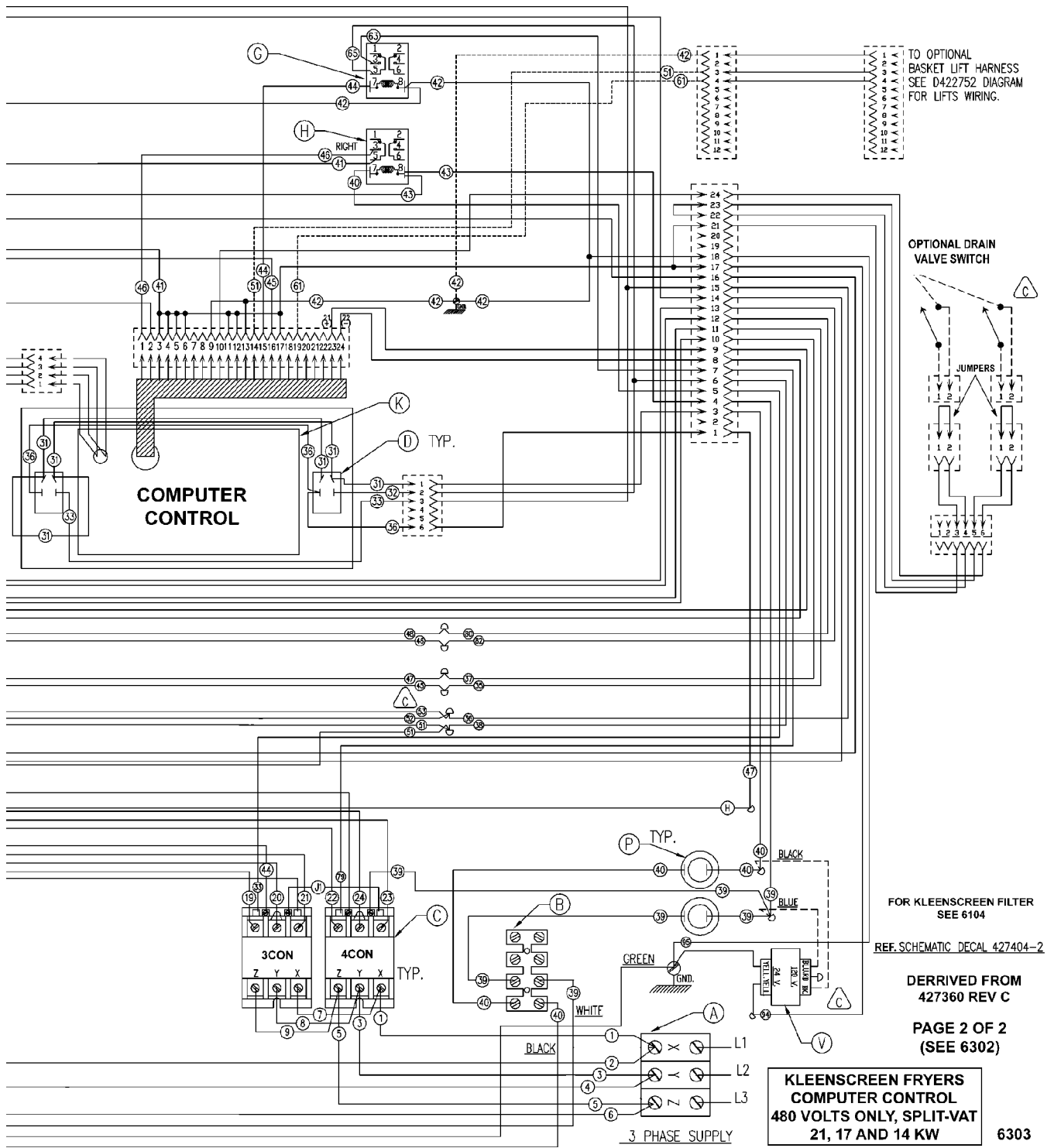

# TROUBLESHOOTING

## SOLID STATE CONTROL

SYMPTOM	POSSIBLE CAUSES
Fryer does not heat.	<ol style="list-style-type: none"> <li>1. Power switch OFF or inoperative.</li> <li>2. Main circuit breaker(s) OFF or the fryers internal circuit breaker(s), if applicable, OFF.</li> <li>3. Control circuit fuse 1FU or 2FU OPEN.</li> <li>4. Transformer 2T inoperative.</li> <li>5. Drain valve switch malfunction (if installed).</li> <li>6. Malfunctioning heat control relay R1 (full vat or right side split vat) or R2 on left side split vat only.</li> </ol>
Ventilator OFF, power switch ON, power light ON.	<ol style="list-style-type: none"> <li>1. Ventilator hood circuit breaker OPEN.</li> <li>2. Interlock wiring OPEN.</li> <li>3. Power switch inoperative.</li> </ol>
No heating light, power light ON.	<ol style="list-style-type: none"> <li>1. Temperature control set too low or not calibrated.</li> <li>2. Heating light inoperative.</li> <li>3. Contactor(s) malfunction.</li> <li>4. Control board malfunction.</li> </ol>
No heating light, power light ON, trouble light and first and second high limit lights ON.	<ol style="list-style-type: none"> <li>1. Low oil.</li> <li>2. First high limit inoperative (control board).</li> <li>3. Second high limit OPEN or tilt switch OPEN or tilt switch malfunction.</li> <li>4. Contactor(s) malfunction.</li> <li>5. Control board malfunction.</li> </ol>
Excessive time to melt shortening (more than 45 minutes).	<ol style="list-style-type: none"> <li>1. Melt cycle timing incorrect (control board).</li> <li>2. Heating elements malfunctioning.</li> <li>3. Supply power incorrect voltage.</li> </ol>
Fryer shuts down on first high limit and first high limit light ON.	<ol style="list-style-type: none"> <li>1. Low oil.</li> <li>2. Control not calibrated.</li> <li>3. Contactor(s) malfunction.</li> <li>4. Control board malfunction.</li> </ol>
Fryer shuts down on second high limit, power light ON, no first high limit light and second high limit light ON.	<ol style="list-style-type: none"> <li>1. Low oil.</li> <li>2. First high limit "light" inoperative.</li> <li>3. Second high limit OPEN or tilt switch OPEN or tilt switch malfunction.</li> <li>4. Contactor(s) malfunction.</li> <li>5. Control board malfunction.</li> </ol>
Thermostat out of calibration by more than 25°F.	<ol style="list-style-type: none"> <li>1. Probe touching element.</li> <li>2. Probe malfunction.</li> <li>3. Control board malfunction.</li> </ol>
Light(s) not ON when required.	<ol style="list-style-type: none"> <li>1. Light inoperative.</li> <li>2. Wiring problem.</li> </ol>

## COMPUTER CONTROL

**NOTE:** The computer control is also used in other equipment, therefore it is possible for unrelated error prompts to appear if a problem occurs in the computer main harness plug.

SYMPTOM	POSSIBLE CAUSES
Fryer does not heat.	<ol style="list-style-type: none"> <li>1. Power switch OFF or inoperative.</li> <li>2. Main circuit breaker(s) OFF or the fryers internal circuit breaker(s), if applicable, OFF.</li> <li>3. Control circuit fuse 1FU or 2FU OPEN.</li> <li>4. Drain valve switch malfunction (if installed).</li> <li>5. Malfunctioning heat control relay R2 (full vat or right side split vat) or R4 on left side split vat only.</li> <li>6. Contactor(s) malfunctioning.</li> <li>7. Computer power supply board or transformer 1T or 2T inoperative.</li> <li>8. Open pins 23 or 24 (12 VDC).</li> <li>9. Open 24 VAC pin 1 (full vat or right side split vat) or pin 2 on left side split vat only.</li> <li>10. Open pin 15 right heat output (full vat or right side split vat), or pin 16 left heat output on left side split vat only.</li> <li>11. Computer main harness wiring problem.</li> <li>12. Malfunctioning computer control.</li> </ol>
Fryer displays "HI TEMP" alarm message.	<ol style="list-style-type: none"> <li>1. Low oil.</li> <li>2. Frying oil temperature above 410°F, heating elements <u>not</u> turning OFF.               <ol style="list-style-type: none"> <li>A. Malfunctioning heat control relay R2 (full vat or right side split vat) or R4 on left side split vat only.</li> <li>B. Contactor(s) malfunctioning.</li> </ol> </li> <li>3. Malfunctioning computer control.               <ol style="list-style-type: none"> <li>A. Pin 15 right heat output (full vat or right side split vat), or pin 16 left heat output on left side split vat only, <u>not</u> turning OFF.</li> </ol> </li> </ol>
Fryer heats slowly.	<ol style="list-style-type: none"> <li>1. Incoming voltage incorrect.</li> <li>2. Heating element(s) malfunction.</li> </ol>
Fryer displays "CALL SERVICE"	<ol style="list-style-type: none"> <li>1. Probe malfunction.</li> <li>2. Failed self-check.</li> <li>3. Malfunctioning computer control.</li> </ol>
Fryer displays "IGN FAILURE"	<ol style="list-style-type: none"> <li>1. Pins 3, 4, 5 or 6 <u>not</u> connected to 24VAC.</li> </ol>
Fryer displays "DRAIN OPEN"	<ol style="list-style-type: none"> <li>1. Drain "ball" valve left OPEN.</li> <li>2. Pin 10 not connected to 24VAC.</li> <li>3. Drain valve switch malfunction (if installed).</li> </ol>
Fryer displays "OFF"	<ol style="list-style-type: none"> <li>1. Second high limit OPEN or tilt switch OPEN or tilt switch malfunction.</li> </ol>

## COMPUTER CONTROL HARNESS PIN-OUTS CHART

**NOTE:** The terms right and left throughout the table below have the following meanings: Right equals Full vat or right side split vat; Left equals left side, split vat only.

<b>COMPUTER CONTROL PIN-OUTS</b>			
PIN #	DESCRIPTION	PIN #	DESCRIPTION
1	Right power input "status"	13 <sup>2</sup>	24 VAC input ground
2	Left power input "status"	14	Right basket output
3 <sup>1</sup>	Right input	15	Right heat output
4 <sup>1</sup>	Left input	16	Left heat output
5 <sup>1</sup>	Right input	17 <sup>1</sup>	24 VAC main input
6 <sup>1</sup>	Left input	18	no connection
7	no connection	19	Left basket output
8	no connection	20	no connection
9 <sup>2</sup>	ground	21	no connection
10	Drain valve switch(es) (if installed) input "status"	22	no connection
11 <sup>1, 3</sup>	Door switch input "status"	23	Computer power input (+) 12 VDC nominal
12 <sup>1, 2</sup>	Full vat or Split vat mode Input	24	Computer power input (-) 12 VDC
<p><b>NOTES:</b></p> <ol style="list-style-type: none"> <li>1. 24VAC - control system main input to pin 17; jumpered to pins 3, 4, 5, 6, 11 &amp; 12 (split vat only). Input to jumpered pins must be present or computer control will not function properly.</li> <li>2. 24VAC ground - control system input to pin 13; jumpered to pins 9 &amp; 12 (full vat only). Input to jumpered pins must be present or computer control will not function properly.</li> <li>3. Pin 11 - door switch no longer used on these models. Input must remain or computer will display "DOOR OPEN".</li> </ol>			

## KLEENSCREEN FILTERING SYSTEM

SYMPTOM	POSSIBLE CAUSES
Oil not filtering, pump motor is ON.	<ol style="list-style-type: none"> <li>1. Filter screen plugged.</li> <li>2. Clog in filter system lines.</li> </ol> <p><b>NOTE:</b> If using solid shortening, when all filtered oil is returned to the vat and filter power switch is OFF, open the filter drawer approximately one inch. Allow the remaining shortening in the line to drain into the filter tank to prevent possible clogging after the shortening cools and solidifies. Close the filter drawer when complete.</p> <ol style="list-style-type: none"> <li>3. Oil/Shortening below 300°F to "thick".</li> <li>4. Filter valve switch malfunction.</li> <li>5. Filter valve mechanical malfunction.</li> <li>6. Pump is inoperative.</li> </ol>
Oil not discarding, pump motor ON.	<ol style="list-style-type: none"> <li>1. Filter screen plugged.</li> <li>2. Clog in filter system lines.</li> </ol> <p><b>NOTE:</b> If using solid shortening, when all filtered oil is returned to the vat and filter power switch is OFF, open the filter drawer approximately one inch. Allow the remaining shortening in the line to drain into the filter tank to prevent possible clogging after the shortening cools and solidifies. Close the filter drawer when complete.</p> <ol style="list-style-type: none"> <li>3. Oil/Shortening below 300°F to "thick".</li> <li>4. Discard valve switch malfunction.</li> <li>5. Discard valve mechanical malfunction.</li> <li>6. Discard hose connection not fully engaged.</li> <li>7. Pump is inoperative.</li> </ol>
Pump motor is not running.	<ol style="list-style-type: none"> <li>1. Filter power switch inoperative.</li> <li>2. Filter/discard handle not extended.</li> <li>3. Filter/discard valve switch malfunction.</li> <li>4. Filter relay malfunction.</li> <li>5. Pump motor inoperative.</li> </ol>

# - NOTES -

# - NOTES -

# CONDENSED SPARE PARTS LIST

## KLEENSCREEN FILTER

PART NUMBER	DESCRIPTION	NOTES
411496-B4	Lighted Rocker Switch, Filter	
417792-1	Pump and Motor Assy, Kleenscreen filter	
411497-A3	Relay, Filter Circuit, 24v Coil	

## ER SERIES ELECTRIC KLEENSCREEN FRYERS

PART NUMBER	DESCRIPTION	ERD	ERC	NOTES
411496-F7	"Tilt Limit Switch", "Filter valve switch" and "Discard valve switch".	X <sup>1</sup>	X <sup>2</sup>	
411496-B9	Rocker Switch, Momentary on/off, Center off	X		
416535-4	Relay, 24v Coil		X	
414146-2	Hi-limit Thermostat	X <sup>1</sup>	X <sup>2</sup>	
FE-023-55	Fuse, Holder	X <sup>1</sup>	X <sup>2</sup>	
FE-019-40	Fuse, 15 Amp	X <sup>1</sup>	X <sup>2</sup>	
414142-1	Temperature Probe, Thermistor	X <sup>1</sup>		
417876-1	Resistor, Heat Light	X <sup>1</sup>		
415144-12	Temperature Control Board	X <sup>1</sup>		
415638-G1	Potentiometer Assy.	X <sup>1</sup>		
411496-B1	Rocker Switch, Fry / Melt	X <sup>1</sup>		
411497-C3	Contactor, 3 Pole 40 Amp 120v Coil	X <sup>1</sup>	X <sup>2</sup>	
411497-C5	Contactor, 3 Pole 40 Amp 240v Coil	X <sup>1</sup>	X <sup>2</sup>	
418159-1	Cam Switch, Basket Lift	X <sup>1</sup>	X <sup>2</sup>	
418156-1	Gear Motor, Basket Lift	X <sup>1</sup>	X <sup>2</sup>	
416741-G5	Element, 208v 14kw,	X <sup>1</sup>	X <sup>2</sup>	
416741-G7	Element, 240v, 14kw	X <sup>1</sup>	X <sup>2</sup>	
416741-G9	Element, 208v 17kw,	X <sup>1</sup>	X <sup>2</sup>	
416741-G11	Element, 240v, 17kw	X <sup>1</sup>	X <sup>2</sup>	
422737-2	Temperature Probe, Thermistor		X <sup>2</sup>	
419574	Power Supply Board, Computer 12vac-12vdc		X <sup>2</sup>	
419557-7	Computer Control		X <sup>2</sup>	
416535-7	Relay, 240v Coil		X <sup>2</sup>	
419572-G2	Transformer, 240-12v		X <sup>2</sup>	
411500-12	Transformer, 120-24v	X <sup>1</sup>	X <sup>2</sup>	
411500-13	Transformer, 240-24v	X <sup>1</sup>	X <sup>2</sup>	
1 = COMMON TO STANDARD ERD SERIES FRYERS 2 = COMMON TO STANDARD ERC SERIES FRYERS				