

**Select**  
by **southbend**

**IMPORTANT FOR FUTURE REFERENCE**

Please complete this information and retain this manual for the life of the equipment:

Model #: \_\_\_\_\_

Serial #: \_\_\_\_\_

Date Purchased: \_\_\_\_\_

**OPERATOR'S MANUAL**

**Free-Standing, Floor Model**

**GFS Series Tube Fryers**

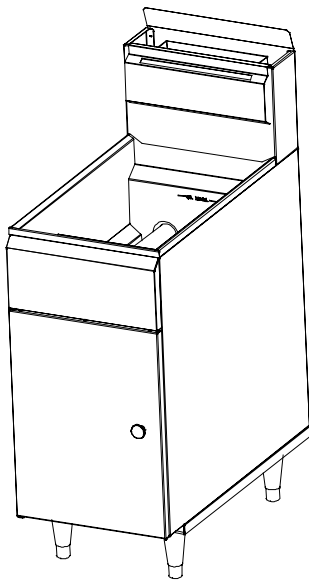

Model GFS35

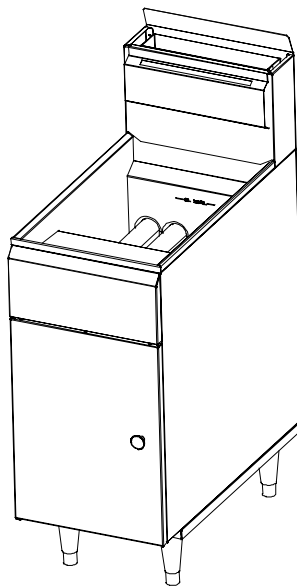

Model GFS45

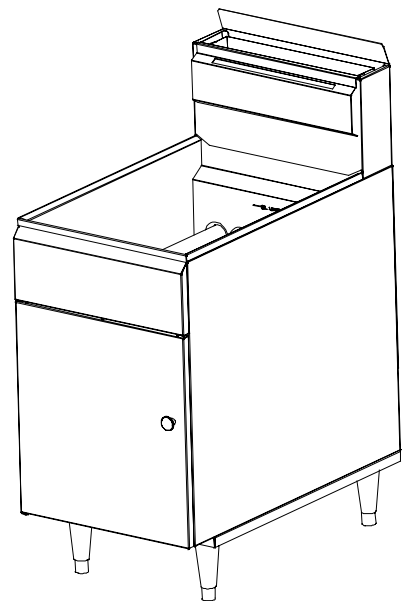

Model GFS65

**! WARNING**

Improper installation, adjustment, alteration, service or maintenance can cause property damage, injury or death. Read the installation, operating and maintenance instructions thoroughly before installing or servicing this equipment.

1100 Old Honeycutt Road, Fuquay-Varina, NC 27526  
(800) 348-2558 or (919) 552-9161 • FAX (800) 348-2558 or (919) 552-9798



# Safety Precautions

A0(Z )2184(A)(0(Rt)-0(Ds)TJETI53.001335788 77.4 -77.4 refI53.001335788 77.4 -77.4 refI53481335788 4746.72-77.4 refI5207

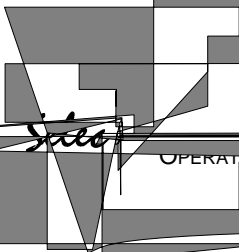
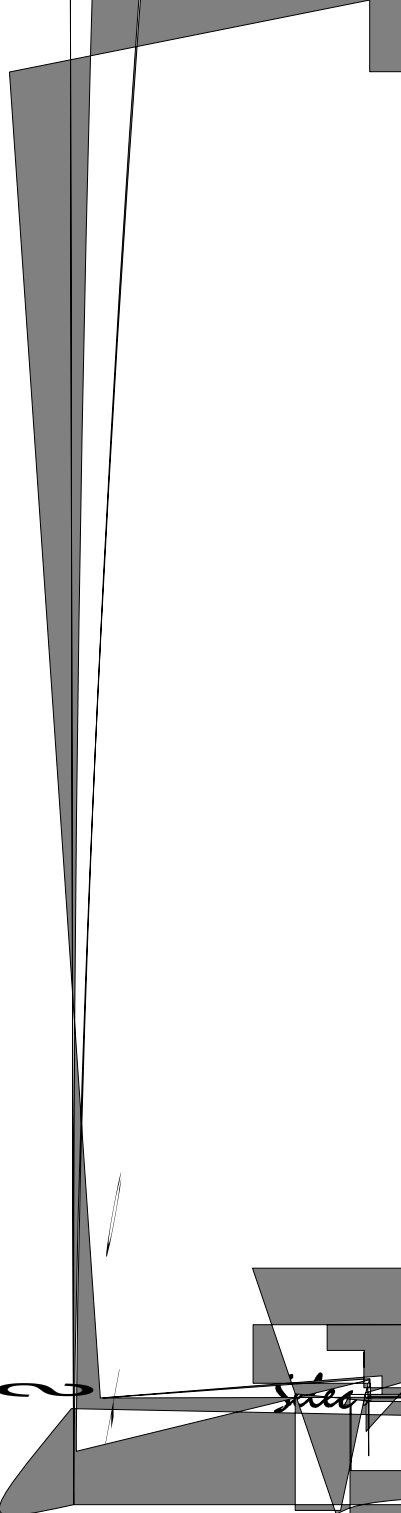

*Handwritten signature or mark.*

OPERATOR'S MANUAL FOR SERIES 1

1988





### Gas Supply Requirements and Burner Information

Supply pressure should be greater than 7" W.C. for natural gas or greater than 11" W.C. for propane. One 3/4" NPT male connector located on back (see illustrations on pages 4 and 7).

Model	Burners	Gas Type	Manifold Pressure	Number per Unit	Rate Each BTUs/Hour	Total Rate BTUs/Hour	Orifice Size
GFS35	Main	Natural	4" W.C.	3	35,000	105,000	#36 - 0.1065" dia.
		Propane	10" W.C.	3	30,000	90,000	#52 - 0.0635" dia.
	Pilot	Natural	4" W.C.	1	900	900	#77 - 0.0180" dia.
		Propane	10" W.C.	1	900	900	0.0110" dia.
GFS45	Main	Natural	4" W.C.	4	35,000	140,000	#36 - 0.1065" dia.
		Propane	10" W.C.	4	30,000	120,000	#52 - 0.0635" dia.
	Pilot	Natural	4" W.C.	1	900	900	#77 - 0.0180" dia.
		Propane	10" W.C.	1	900	900	0.0110" dia.
GFS65	Main	Natural	4" W.C.	5	35,000	175,000	#36 - 0.1065" dia.
		Propane	10" W.C.	5	30,000	150,000	#52 - 0.0635" dia.
	Pilot	Natural	4" W.C.	1	900	900	#77 - 0.0180" dia.
		Propane	10" W.C.	1	900	900	0.0110" dia.

### Electrical Requirement

No external electric power is required.

### Clearances

See page 9.



INSTALLATION

# INSTALLATION

## NOTICE

Installation must conform with local codes, or in the absence of local codes, with the *National Fuel Gas Code, ANSI Z223.1, Natural Gas Installation Code, CAN/CGA-B149.1, or the Propane Installation Code, CAN/CGA-B149.2*, as applicable.

## NOTICE

These installation procedures must be followed by qualified personnel or warranty will be void. Local codes regarding installation vary greatly from one area to another. The National Fire Protection Association, Inc. states in its NFPA 96 latest edition that local codes are the "authority having jurisdiction" when it comes to installation requirements for equipment.

### Step 1: Unpack

#### IMMEDIATELY INSPECT FOR SHIPPING DAMAGE

All containers should be examined for damage before and during unloading. The freight carrier has assumed responsibility for safe transit and delivery. If damaged equipment is received, either apparent or concealed, a claim must be made with the delivering carrier.

Apparent damage or loss must be noted on the freight bill at the time of delivery. The freight bill must then be signed by the carrier representative (Driver). If the bill is not signed, the carrier may refuse the claim. The carrier can supply the necessary forms.

A request for inspection must be made to the carrier within 15 days if there is concealed damage or loss that is not apparent until after the equipment is uncrated. The carrier should arrange an inspection. Be certain to hold all contents plus all packing material.

1. Uncrate carefully. Report any hidden damage to the freight carrier IMMEDIATELY.
2. Do not remove any tags or labels until unit is installed and working properly.

### Step 2: Install Flue Riser

The flue riser assembly is packed separately in the fryer shipping crate. Attach the flue riser to the top rear of the fryer (see illustration on page 7).



Installation

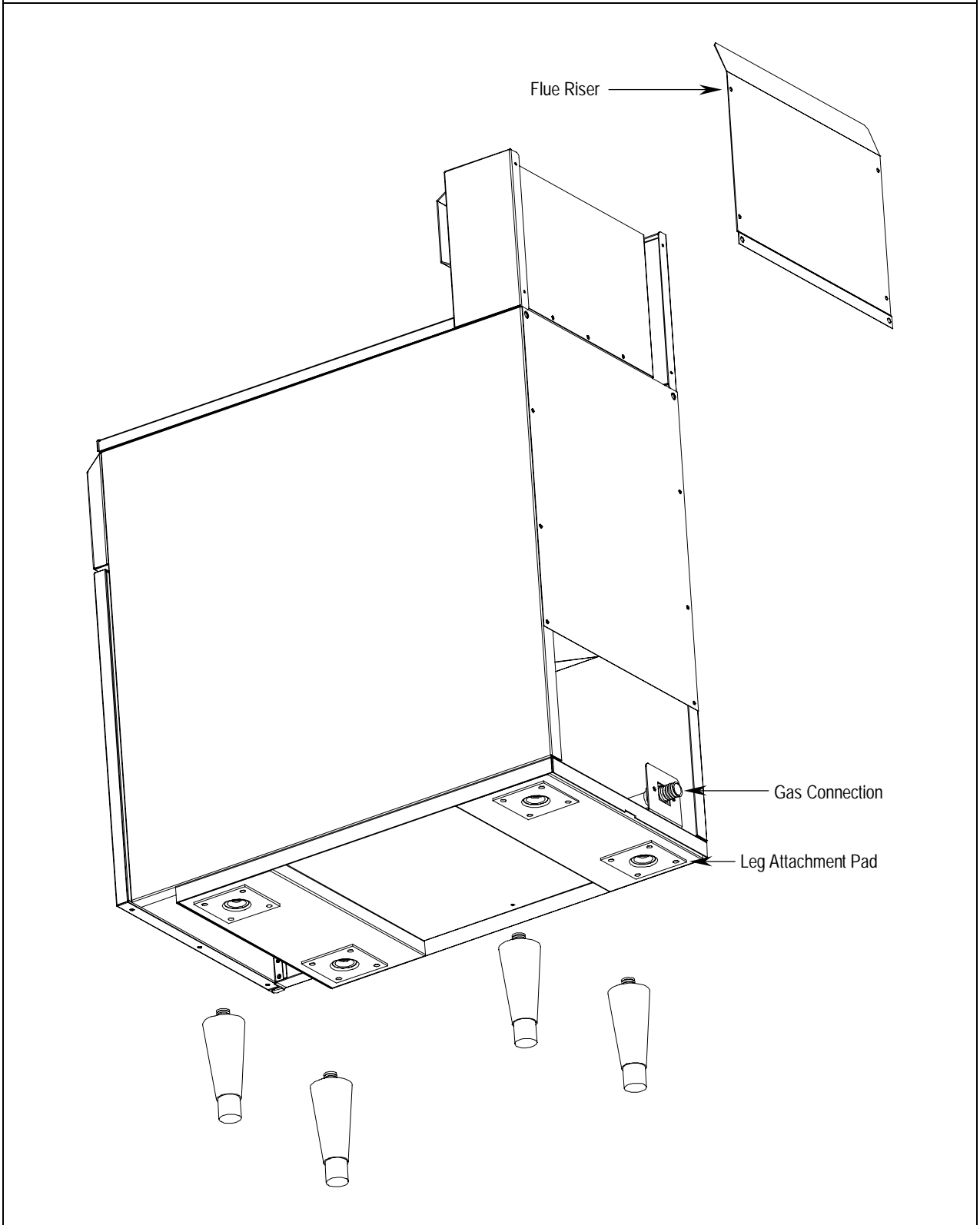

INSTALLATION



Step 3: Install the Legs (or Casters) and Restraints

A set of legs or casters is packed with the fryer. A threaded pad is fastened to the base frame at each corner (see illustration on page 7). Each leg or caster has a similar mating thread. When casters have been ordered, the casters are provided with a Zerk fitting for proper lubrication when required.

1. Raise fryer sufficiently to allow legs or casters to be screwed into the pads. For safety, "shore up" and support the fryer with an adequate blocking arrangement strong enough to support the load.
2. Screw the four legs or casters to the pads on the bottom of the fryer. When casters have been ordered, the casters having a locking-brake should be attached under the front of the fryer.
3. Lower the fryer gently. Never drop or allow the fryer to fall.
4. Use a level to make sure that the fryer is level. Each caster, or the tubular-end of each leg, can be screwed in or out to lower or raise each corner of the fryer. For fryers having casters, tighten the lock nuts after the unit has been leveled.
5. Attach restraints as required by local codes.

**NOTICE**

Unit must be level to assure maximum performance. Improper leveling may void warranty.

**NOTICE**

Adequate restraining means must be attached to rear of appliance when installed. Installation must conform to local codes as applicable.

 **WARNING**

If disconnection of the restraint is necessary to move the appliance for cleaning, etc., reconnect it when the appliance is moved to its original installed position.

 **WARNING**

For an appliance equipped with casters, the installation shall be made with a connector that complies with the Standard for *Connectors for Movable Gas Appliances, ANSI Z21.69* or *Connectors for Moveable Gas Appliances, CAN/CGA-6.16*, and a quick-disconnect device that complies with the Standard for *Quick-Disconnect Devices for Use With Gas Fuel, ANSI Z21.41*, or *Quick Disconnect Devices for Use with Gas Fuel, CAN1-6.9*. Adequate means must be provided to limit the movement of the appliance without depending on the connector and the quick-disconnect device or its associated piping to limit the appliance movement.

 **WARNING**

All GFS Series Fryers must be restrained to prevent tipping in order to avoid the splashing of hot liquid. The means of restraint may be the manner of installation, such as connection to a battery of appliances or installing the fryer in an alcove, or by separate means, such as adequate ties.





Step 4: Check Clearances and Ventilation

Select a firm, level location for your Southbend fryer. Leave clearance, whenever possible, so that access from the rear is possible to permit cleaning. If the unit is to be set on non-combustible flooring, such as a concrete slab, 3 inches minimum toe room must be provided to prevent restriction of the air opening in the bottom of the unit.

**! WARNING**

There must be adequate clearance between fryer(s) and construction. Clearance must also be provided in front for servicing and for operation.

Minimum Clearances:

	From Combustible Construction	From Non-Combustible Construction
Sides	7"	0"
Rear	7"	0"

*ALL GFS SERIES FRYERS SHALL BE INSTALLED WITH AT LEAST A 16 INCH SPACE BETWEEN THE FRYER AND SURFACE FLAMES FROM ADJACENT EQUIPMENT.*

No additional side and rear clearance is required for service as the fryer is serviceable from the front.

INSTALLATION

**! WARNING**

Improper ventilation can result in personal injury or death. Ventilation that fails to properly remove flue products can cause headaches, drowsiness, nausea, or could result in death.

All units must be installed in such a manner that the flow of combustion and ventilation air is not obstructed. Provisions for adequate air supply must also be provided. Do NOT obstruct the bottom front of the unit, as combustion air enters through this area. Be sure to inspect and clean the ventilation system according to the ventilation equipment manufacturer's instructions.

**NOTICE**

Proper ventilation is the owner's responsibility. Any problem due to improper ventilation will not be covered by the warranty.

Due to the variety of problems that can be caused by outside weather conditions, venting by canopies or wall fans is preferred over any type of direct venting. It is recommended that a canopy extend 6" past the appliance and the bottom edge be located 6'6" from the floor. Filters should be installed at an angle of 45° or more from the horizontal. This position prevents dripping of grease and facilitates collecting the run-off grease in a drip pan, unusually installed with a filter. A strong exhaust fan tends to create a vacuum in the room and may interfere with burner performance or may extinguish pilot flames. Fresh air openings approximately equal to the fan area will relieve such a vacuum. In case of unsatisfactory performance on any appliance, check the appliance with the exhaust fan in the "OFF" position. Do this only long enough to check equipment performance, then turn hood back on and let it run to remove any exhaust that may have accumulated during the test.

The exhaust fan should be installed at least 2 feet above the vent opening at the top of the fryer.

This unit is not intended to be connected directly to an outside flue.





Step 5: Gas Connection

A 3/4" male NPT line for the gas connection is located near the lower left rear corner of the fryer (see illustration on page 7). The serial plate (located inside the front door of the fryer) indicates the type of gas the unit is equipped to burn (natural gas or propane). The fryer should be connected ONLY to the type of gas for which it is equipped.

A millivoltage circuit diagram is located inside the front door of the fryer.

All Southbend equipment is adjusted at the factory; however, pilot height should be checked at installation and adjusted, if necessary (see page 22).

For orifice sizes and pressure regulator settings, see the chart on page 5. If the fryer is being installed at over 2,000 feet altitude and that information was not specified when ordered, contact the appropriate authorized Southbend Service Representative or the Southbend Service Department. Failure to install with proper orifice sizing will result in poor performance and may void the warranty.

If applicable, the vent line from the gas appliance pressure regulator shall be installed to the outdoors in accordance with local codes or, in the absence of local codes, with the *National Fuel Gas Code, ANSI Z223.1, Natural Gas Installation Code, CAN/CGA-B149.1*, or the *Propane Installation Code, CAN/CGA-B149.2*, as applicable.

An adequate gas supply is imperative. Undersized or low pressure lines will restrict the volume of gas necessary for satisfactory performance. A combination gas valve and pressure regulator, which is provided with each unit, is set to maintain a 4" W.C. manifold pressure for natural gas or 10.0" W.C. manifold pressure for propane gas. However, to maintain these conditions the pressure on the supply line, when all units are operating simultaneously, should not drop below 7" W.C. for natural gas or 11" W.C. for propane gas. Fluctuations of more than 25% on natural gas or 10% on propane gas will create problems and affect burner operating characteristics. A 1/8" tap to measure the manifold pressure is located on the combination gas valve, which is on the burner manifold located directly below the burners inside the cabinet.

Purge the supply line to clean out dust, dirt, or other foreign matter before connecting the line to the unit.

It is recommended that an individual manual shutoff valve be installed in the gas supply line to the unit.

Use pipe joint compound that is suitable for use with both natural and LP gas on all threaded connections.

**! CAUTION**

ALL PIPE JOINTS AND CONNECTIONS MUST BE TESTED THOROUGHLY FOR GAS LEAKS. USE ONLY SOAPY WATER FOR TESTING ON ALL GASES. NEVER USE AN OPEN FLAME TO CHECK FOR GAS LEAKS. ALL CONNECTIONS MUST BE CHECKED FOR LEAKS AFTER THE UNIT HAS BEEN PUT INTO OPERATION. TEST PRESSURE SHOULD NOT EXCEED 14" W.C.

**! CAUTION**

*THIS APPLIANCE AND ITS INDIVIDUAL COMBINATION GAS VALVE MUST BE DISCONNECTED FROM THE GAS SUPPLY PIPING SYSTEM DURING ANY PRESSURE TESTING OF THAT SYSTEM AT TEST PRESSURES IN EXCESS OF 1/2 PSIG (3.45 kPa).*

The appliance must be isolated from the gas supply piping system by closing its individual manual shutoff valve during any pressure testing of the gas supply piping system at test pressures equal to or less than 1/2 psi (3.45 kPa).

Connect the gas supply directly to the 3/4" male NPT connector located near the lower left rear corner of the fryer. When tightening the supply pipe, be sure to hold the mating connector extending from the unit securely with a wrench. This will prevent any damage or distortion to the internal piping and controls of the unit.

After connecting the gas supply, check again that the fryer is level. Use a long spirit level four ways; across the front and rear of the frypot, and along each edge.





**! CAUTION**

*IF YOU SMELL GAS DURING THE LIGHTING PROCEDURE, IMMEDIATELY SHUT OFF THE GAS*



# OPERATION

## NOTICE

These procedures must be followed by qualified personnel or warranty will be voided.

All Southbend GFS Series Tube Fryers are immersion tube fryers. This is the most efficient method of transmitting heat into the oil. The tubes are actually large heat exchangers. Each tube is heated by a burner at its front that propels its flame and heat into the tube, toward the rear, where it is vented into a flue box. The combined heat transfer area of the tubes is much greater than the other types using element coils or under-fired pots. Consequently, heat transfer per square inch is lower, as is the temperature, but because of the increased surface area, immersion tube fryers transfer more heat into the oil. The lower temperature of the heating surface prevents scorching and carbonization of the oil. Higher heat transfer rate gives faster recovery between loads.

Another advantage of immersion tube fryers is the cold zone. As oil is heated it passes between and over the tubes and rises into the frying zone, where it imparts heat into the product. After giving up heat, it descends to the cooler zone below the tubes. Food particles and crumbs are dropped and trapped in the cold zone as the oil awaits to be recirculated. The cold zone concept helps keep the oil circulating and clean of debris.

OPERATION

## WARNING BURN HAZARD

Contact with hot oil will cause severe burns. Always use caution. Oil at 200°F is more dangerous than boiling water.

## CAUTION

*NEVER OPERATE THE FRYER WITHOUT SUFFICIENT OIL TO COVER THE TUBES.*

## Lighting

## CAUTION

*IF YOU SMELL GAS DURING THE LIGHTING PROCEDURE, IMMEDIATELY SHUT OFF THE GAS SUPPLY UNTIL THE LEAK HAS BEEN CORRECTED.*

Open the burner compartment door and do the following:

1. Turn thermostat to "OFF" (lowest position).
2. Press down the knob of the combination gas valve, turn it counterclockwise to the "PILOT" position, and continue to press the knob down.

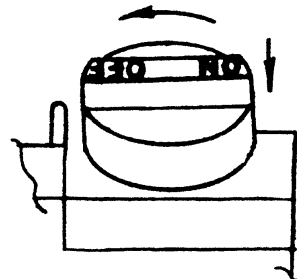



3. While pressing the knob down, use a lit match to ignite the pilot. Continue to press the knob down for about 30 seconds. If the pilot does not stay ignited when the knob is released, repeat the lighting procedure and keep the knob down longer. Adjustment of pilot flame may be necessary.
4. When the pilot stays ignited, turn the knob counterclockwise to the "ON" position. Do not press down on the knob in this step.
5. Do NOT turn the thermostat "ON" until the frypot is filled with oil or solid shortening.

### Shutdown Procedure

**Standby:** Turn knob on the combination gas valve to the "PILOT" position. At this setting, only the pilot burner will remain ignited.

**Complete Shutdown:** Turn knob on the combination gas valve, then press down on the knob and continue to turn to the "OFF" position.

### Relighting

#### **! WARNING**

In the event of a main burner ignition failure, a five minute purge period must be observed prior to re-establishing the ignition source.

1. Shut off all gas.
2. Wait five minutes.
3. Follow the "Lighting" procedure described on page 12.

### Filling the Frypot

1. Close drain valve completely before filling the frypot.
2. When the fryer is new, fill the frypot with water and clean thoroughly (see "Weekly Cleaning" on page 18) in order to remove protective coatings and any foreign matter.
3. The recommended solid shortening capacity for the fry pot is 35 pounds for Model GFS35, 45 pounds for Model GFS45, and 65 pounds for Model GFS65.
4. Remove the basket support frame when filling the frypot with solid shortening.



## Automatic Pilot Valve

The Automatic Pilot Valve provides an automatic safety shutoff for the fryer when the pilot flame is extinguished. When the pilot flame is burning, the valve is held open electromagnetically by the electrical current from a thermopile in the pilot flame. When the pilot flame goes out, generation of current ceases and the valve closes automatically.

## High Limit Control

The GFS Series Tube Fryers are equipped with a secondary heat control that prevents the oil temperature from rising above 450°F. (Because of the accuracy tolerance of the sensor, the oil temperature may reach as high as 475°F.)

In the event the fryer shuts down due to this condition, the oil must be cooled to below 400°F before the pilot burner can be re-ignited. When the oil has cooled, use the “Lighting” procedure on page 12 to place the fryer back in operation. If the problem persists, contact your Southbend Service Representative or the Southbend Service Department.

 **WARNING**

In the event a gas odor is detected, shut down equipment at the combination gas valve and contact the local gas company or gas supplier for service.

OPERATION



# COOKING HINTS

## User Tips

- Smoking oil means that the temperature is too high, or that the oil has broken down.
- Gum in frypot denotes a need for thorough cleaning (see “Weekly Cleaning” on page 18)
- Use different oil for oily foods (mackerel, nutmeg, etc.) than for foods with water-soluble flavors (potatoes, onions, etc.).
- Taste oil for quality. Replace it regularly.
- Poor oil cannot produce good food.

## Gas Saving Tips

Use the following tips to help develop energy-saving procedures and habits. Using less natural or propane gas saves energy, and money, too.

- Limit preheat time to 5 to 10 minutes.
- Set thermostat to desired temperature.
- Do not overheat. Never use temperatures higher than 375°F.
- Turn fryers off during slack periods.
- Filter oil daily. Clean frypot thoroughly at least once a week (see page 18).

## Frying Do's

- Make sure frypot is clean.
- Make sure thermostats are registering and functioning properly.
- Fill frypot only to proper frying level. An oil-level line is stamped on the frypot.
- Maintain proper level of oil in the frypot by occasionally adding fresh solid shortening as the frypot fries down.
- Keep heating tubes covered at all times when heat is on.
- Fry at temperature in the range 325°F to 375°F.
- Turn heat in the frypots to 200°F, or preferably off, between fry periods, or during any periods of time when this is practical.
- Fry foods in amounts only up to a full load; a full loading being the point where the temperature recovers to the dial setting and the thermostat turns off the burner before the food is completely fried or done.
- Remove food baskets from frypot as soon as food is done, allowing food to drain over frypot a minimum of 30 seconds.
- Keep oil as clean as possible at all times, removing immediately any floating burned particles.
- Make sure baskets are sound and don't leak food into the frypot.
- Drain frypot, filter oil, and remove all residue from cold zone at least once daily. Boil out frypot and baskets with detergent at least once a week, scraping off any foreign materials not yielding to the treatment. Rinse frypot several times by filling with fresh water and bringing to boil. Perform the weekly cleaning procedure (see page 18).
- Keep frypots covered when not in use.



## Frying Don'ts

- Don't turn on the fryer with no shortening in the frypot.
- Don't fill the frypot above the line on rear of frypot.
- Don't allow oil in frypot to fry down to the point where there is insufficient oil in which to fry a full load.
- Don't have heat on tubes when they are not entirely covered with frying oil.
- Don't allow oil in frypot to be heated above 375°F and never turn thermostats to 400°F or over, even when bringing up the temperature.
- Don't allow unnecessary moisture or breading materials to get into frypot.
- Don't allow oil in frypot to remain at frying temperature for long periods of time without frying taking place.
- Don't overload frypot with food to be fried.
- Don't pack the food too tightly in the baskets.
- Don't add foreign oils to frypot such as bacon, beef drippings, or waste oil.
- Don't fry bacon in frypot.
- Don't salt food over or near the frypot.
- Don't allow visible burned particles to remain floating in frypot.
- Don't allow exhaust stack accumulations to drip back into the frypot.

## Performance

COOKING HINTS

Typical Production	Model GFS35	Model GFS45	Model GFS65
Potatoes — Raw to Finished	65-70 lbs. per hour	100-105 lbs. per hour	115-120 lbs. per hour
— Blanched to Finished	280-285 lbs. per hour	320-325 lbs. per hour	355-360 lbs. per hour
Chicken — Raw to Finished	40-45 lbs. per hour	50-55 lbs. per hour	55-60 lbs. per hour
— Blanched to Finished	80-85 lbs. per hour	95-100 lbs. per hour	105-110 lbs. per hour





# CLEANING

Southbend equipment is constructed with the best quality materials and is designed to provide durable service when properly maintained. To expect the best performance, your equipment must be maintained in good condition and cleaned daily. Naturally, the frequency and extent of cleaning depends on the amount and degree of usage.

Following daily and more extensive periodic maintenance procedures will increase the life of your equipment. Climatic conditions (e.g., salt air) may result in the need for more thorough and more frequent cleaning in order to keep equipment performing at optimal levels.



## WARNING: BURN HAZARD

If necessary to move the fryer for cleaning, etc., drain oil first to avoid death or serious injury.

## NOTICE

Adequate restraining means must be attached to rear of appliance when installed. Installation must conform to local codes as applicable.



## WARNING

If disconnection of the restraint is necessary to move the appliance for cleaning, etc., reconnect it when the appliance is moved to its originally installed position.



## WARNING

For an appliance equipped with casters, the installation shall be made with a connector that complies with the Standard for *Connectors for Movable Gas Appliances, ANSI Z21.69* or *Connectors for Moveable Gas Appliances, CAN/CGA-6.16*, and a quick-disconnect device that complies with the Standard for *Quick-Disconnect Devices for Use With Gas Fuel, ANSI Z21.41*, or *Quick Disconnect Devices for Use with Gas Fuel, CAN1-6.9*. Adequate means must be provided to limit the movement of the appliance without depending on the connector and the quick-disconnect device or its associated piping to limit the appliance movement.

CLEANING

## Daily Cleaning

1. Turn combination gas valve knob to "PILOT" position.
2. Place suitable container under the drain and drain the frypot completely.
3. Remove the basket support frame and flush out any sediment remaining in the frypot with a little hot oil.
4. Wipe off the basket support frame and the inside of the frypot with a clean cloth.



## CAUTION

SOME AREAS OF THE FRYPOT MAY BE HOT!



## CLEANING

## GFS SERIES TUBE FRYERS

5. Close drain valve and strain the oil back into the frypot through several thicknesses of cheesecloth, or filter it back using a filter machine.

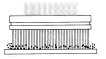

Darkened areas, called “heat tint,” sometimes appear on stainless steel surfaces where the area has been subjected to excessive heat. These darkened areas are caused by thickening of the protective surface of the stainless steel and are not harmful. Heat tint can normally be removed by the above cleaning techniques, but tint which does not respond to that procedure calls for a vigorous scouring in the direction of the polish lines, using SCOTCH-BRITE scouring pads or a STAINLESS scouring pad in combination with a powered cleanser. Heat tint action may be lessened by not applying, or by reducing, heat to equipment during slack periods.



# SERVICE

## NOTICE

**Warranty will be void and the manufacturer is relieved of all liability if:**

- (A) Service work is performed by other than a qualified technician,**
- OR**
- (B) Other than genuine Southbend replacement parts are installed.**

## WARNING

Adjustments and service work may be performed only by a qualified technician who is experienced in, and knowledgeable with, the operation of commercial gas cooking equipment. However, to assure your confidence, contact your Southbend Service Representative (or the Southbend Service Department) for reliable service, dependable advice or other assistance, and for genuine factory parts.

## WARNING

Appliances equipped with casters have been installed with a restraint to limit their movement to prevent damage to the gas supply connecting system. If disconnection of this restraint is necessary to move the appliance for cleaning, etc., reconnect it when the appliance is moved to its original installed position.

## Adjustments

All units are adjusted at the factory. In case of problems in operation at initial installation, check type of gas and manifold pressure and compare with information listed on the serial plate.

### Checking and Adjusting Main Burners

The main burners should burn with a steady blue flame, and the inner cone of the flame from each port should be about 3/4" long. The flame from each main burner should enter each heat tube without touching the front of the frypot or the sides, top, or bottom of each tube.

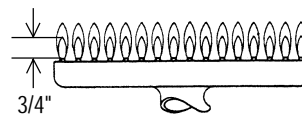

Normal Flame

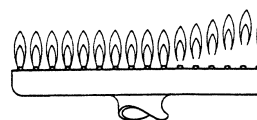

Blowing or Lifting Flames  
(too much air)

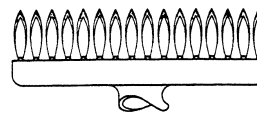

Yellow Tips  
(too little air or too much gas)

SERVICE

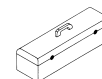

## Checking and Adjusting Pressure Regulator

The combination gas valve and pressure regulator is factory set at 4" W.C. for natural gas and 10" W.C. for propane gas. To check the manifold pressure, do the following:

1. Turn thermostat "OFF" (lowest position) and combination gas valve knob to the "PILOT" setting.
2. Remove pressure tap plug from burner manifold located directly below the burners in the cabinet.
3. Install a fitting appropriate to connect a manometer.
4. Turn combination gas valve to "ON" position and thermostat to "ON." The burners will ignite. Be certain that sufficient oil is covering the tubes.
5. With burners on, read manometer.
6. If the manometer does not read 4" W.C. for natural gas, or 10" W.C. for propane gas, adjust regulator.
7. Remove regulator adjustment screw cap (see diagram on page 24).
8. With small screwdriver rotate adjustment screw "CLOCKWISE" to increase or "COUNTERCLOCKWISE" to decrease pressure. Be sure to adjust with burners "ON."
9. Turn thermostat "OFF" and set combination gas valve knob to "PILOT" position.
10. Remove manometer and replace pressure tap plug.
11. Replace adjustment screw cap.

## Checking and Adjusting Calibration of Thermostat

All thermostat controls are carefully calibrated at the factory (i.e., the dial is properly set to control appliance temperatures accurately). Only a qualified appliance service technician should perform this adjustment.

1. To check appliance temperatures, use a thermocouple-type temperature test instrument or reliable thermometer. Place the thermocouple of test instrument or thermometer in the center of the frypot.
2. Turn the control dial to the temperature setting requiring the greatest accuracy. Allow enough time for temperature to stabilize, or until several temperature readings are identical.
3. Recalibrate if setting and actual temperature differ by more than 10°F.
4. Remove dial from dial shaft "B." Be careful that dial shaft does not rotate in either direction (which would change the dial setting).
5. Hold dial shaft "B" steady and with a screwdriver turn calibration screw "A" clockwise to decrease the temperature, or counterclockwise to increase the temperature.
6. Replace dial. Let the appliance operate until the temperature has stabilized before a final check is made to determine whether or not the calibration has been corrected.
7. Once correct, seal the calibration screw with glyptol.

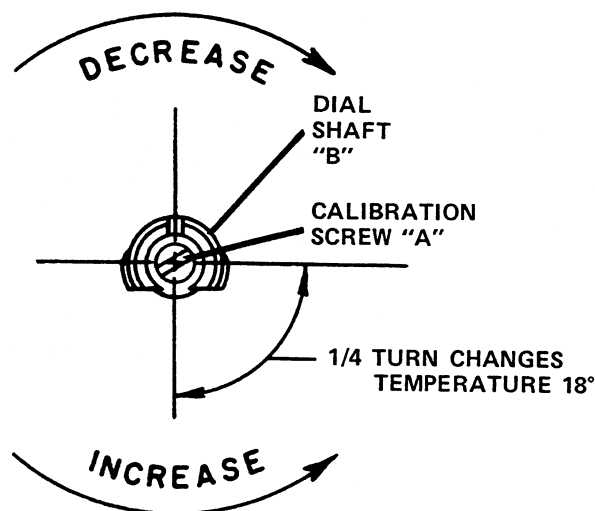

SERVICE



### Checking and Adjusting Auto Safety Pilot

The pilot flame should surround the thermopile for 1/2". It must be large and sharp enough to cause the thermopile to glow a dull red, or sufficient to hold the safety valve open.

1. Remove pilot adjustment cap (see wiring diagram on page 24 for location).
2. Adjust pilot key to provide properly sized flame.
3. Replace pilot adjustment cap.

### Converting from Natural Gas to LP Gas

Obtain a natural-to-LP gas conversion kit (part number 4440493) from your authorized Southbend parts distributor. The kit comes with five LP gas orifice spuds; Model GFS65 uses all five spuds, model GFS45 uses four, and model GFS35 uses three. In the following procedure, refer to the parts diagram on page 28 for Model GFS35, on page 30 for Model GFS45, or on page 32 for Model GFS65.

1. Remove the existing natural gas spud from each burner and replace it with an LP gas spud from the conversion kit.
2. Loosen the compression fitting at the pilot and remove the pilot tubing from the pilot.
3. Remove the two pilot mounting screws.
4. Remove the natural gas pilot orifice from the pilot and replace it with the LP gas pilot orifice from the conversion kit.
5. Remount the pilot assembly, reposition the pilot tubing, and tighten the compression fitting.
6. Partially depress and turn the combination gas valve knob to "OFF."
7. Remove the two screws that pass through the regulator, the regulator, and the gasket (see figure at right).
8. Install the new gasket and regulator from the conversion kit using the two screws in the conversion kit.
9. Turn the combination gas valve knob to "PILOT" and light the pilot, then turn the knob to "ON."
10. With the main burners on, test for leaks using a soap solution.
11. Check and adjust the pressure regulator (see procedure on page 21). The pressure should be 10" W.C. for propane gas.

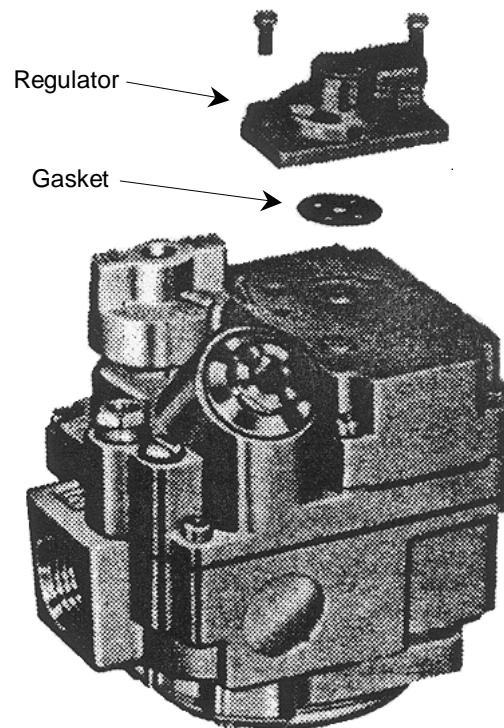

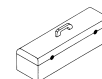

## Troubleshooting

Problem	Likely Cause
Burners do not come on	Gas supply to unit off. Combination gas valve is in "OFF" or "PILOT" position. Pilot not ignited. Thermostat not "ON."
Pilot will not stay ignited	Combination gas valve is in "OFF" position. Pilot gas not adjusted properly. Gas supply to unit off. Bad thermopile. Dirty thermopile connections at combination gas valve or high limit. Bad magnet assembly in combination gas valve. Clogged orifice. Draft condition. Air in gas line. Improper ventilation system. Oil excessively hot.
Pilot produces carbon deposits	Unit connected to wrong gas supply. Pressure not adjusted correctly. Pilot gas not adjusted correctly.
Burners produce carbon deposits	Wrong size orifices. Connected to wrong gas supply. Pressure not adjusted correctly. Flue obstructed.

NOTE: Vibrations or shock caused by shaking or pounding baskets on top surface or by slamming door may cause Hi-Limit Control Switch to open. If this condition persists, additional cushioning may be added to the rubber grommets supporting this control to absorb these shocks.



Wiring Diagram

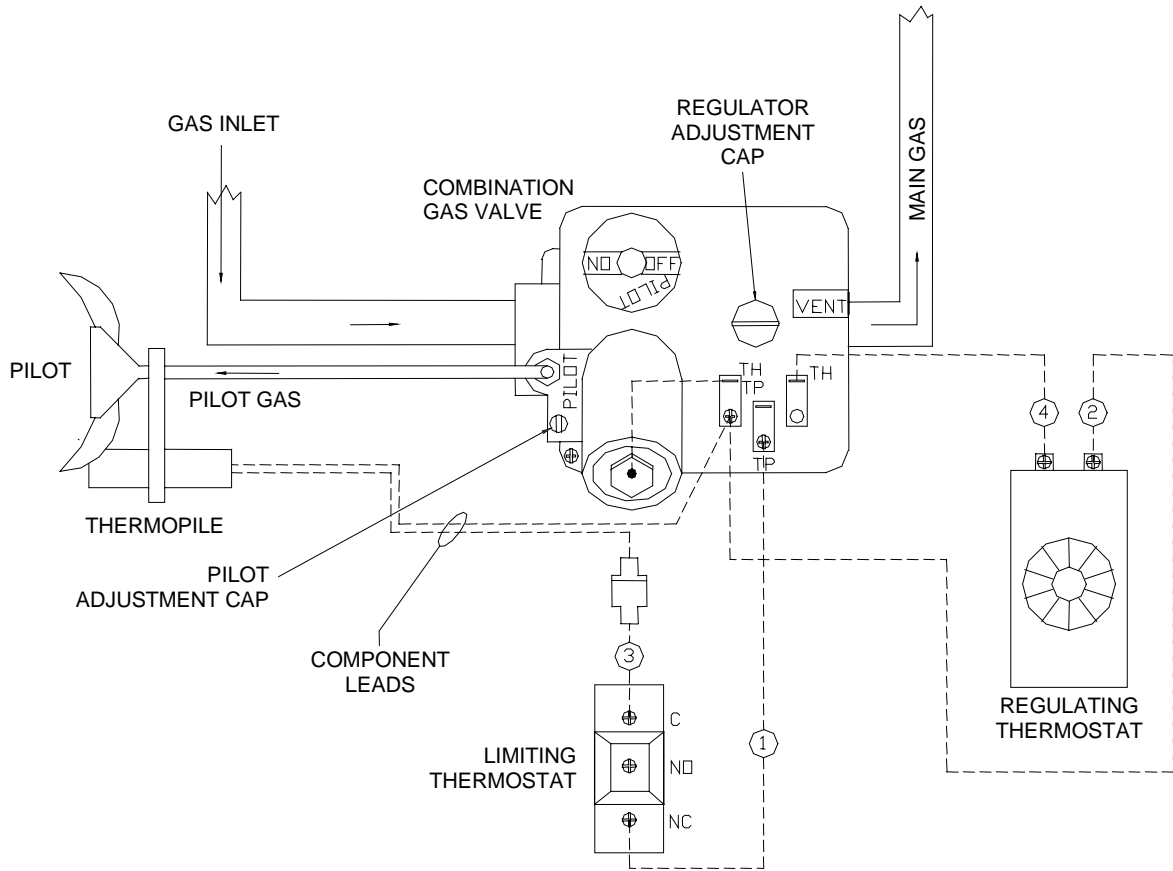

Notes:

1. High limit switch is set to 450°F.
2. Voltage measured across TP/TH and TP with main burner on should be greater than 100 mV.



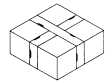

# PARTS

**NOTICE**

INSTALLATION OF OTHER THAN GENUINE SOUTHBEND PARTS WILL VOID THE WARRANTY ON THIS EQUIPMENT.

The serial plate is located inside the front door on the left side.

Replacement parts may be ordered either through a Southbend Authorized Parts Distributor or a Southbend Authorized Service Agency.

When ordering parts, please supply the Model Number, Serial Number, Part Number, and Description.

For parts not listed, consult a Southbend Authorized Parts Distributor or Southbend Authorized Service Agency. Consult the Southbend Authorized Parts/Service Distributor list for the Authorized Parts supplier in your area. If this list is not available, call Southbend at 1-800-348-2558 to obtain this list.

<b>Index of Parts Diagrams</b>	
Page Number	Description
26	Cabinet Parts for GFS35 and GFS45
27	Cabinet Parts for GFS65
28	Gas Train Parts for GFS35
30	Gas Train Parts for GFS45
32	Gas Train Parts for GFS65
34	Frypot Parts for GFS35
35	Frypot Parts for GFS45
36	Frypot Parts for GFS65

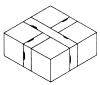

Cabinet Parts for GFS35 and GFS45

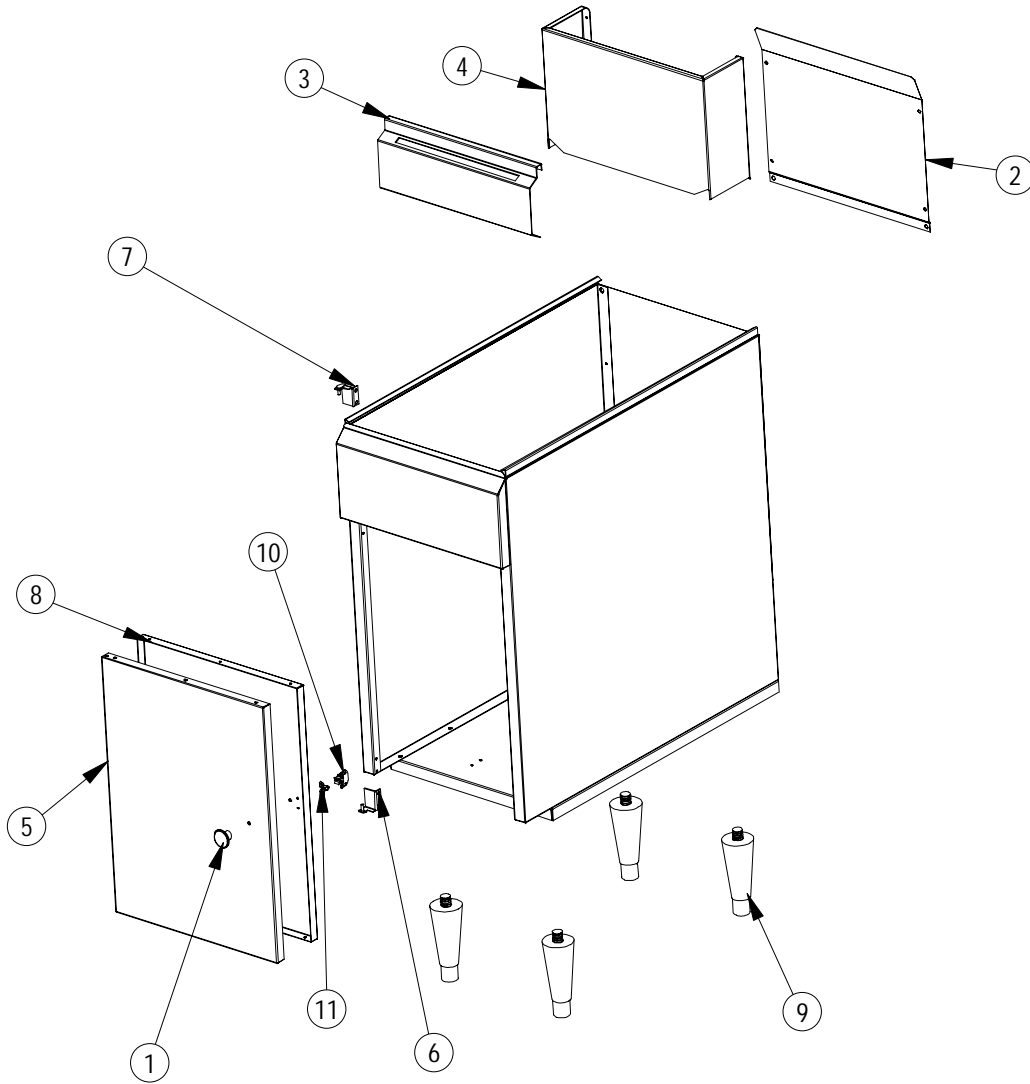

Key	Part Number	Qty	Description
1	1-2849	1	Knob, Door
2	1182216	1	Cover Splasher Rear
3	1182212	1	Fry Panel
4	1182209	1	Splasher Spot Weld
5	1182205	1	Door
6	1182025	1	Bracket, Bottom Door
7	1182024	1	Bracket, Top Door Weld Assembly
8	1182016	1	Panel, Inner Door
*	1172650	1	Leg Pad
9	1178205	1	Leg, Black (set of four)
*	1174265	1	Casters (optional, set of four)
*	1174262	1	Earthquake Legs (optional, set of four)
10	1164133	1	Catch, Door
11	1164132	1	Door Striker
* not shown on drawing.			

PARTS

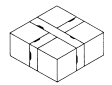

**Cabinet Parts for GFS65**

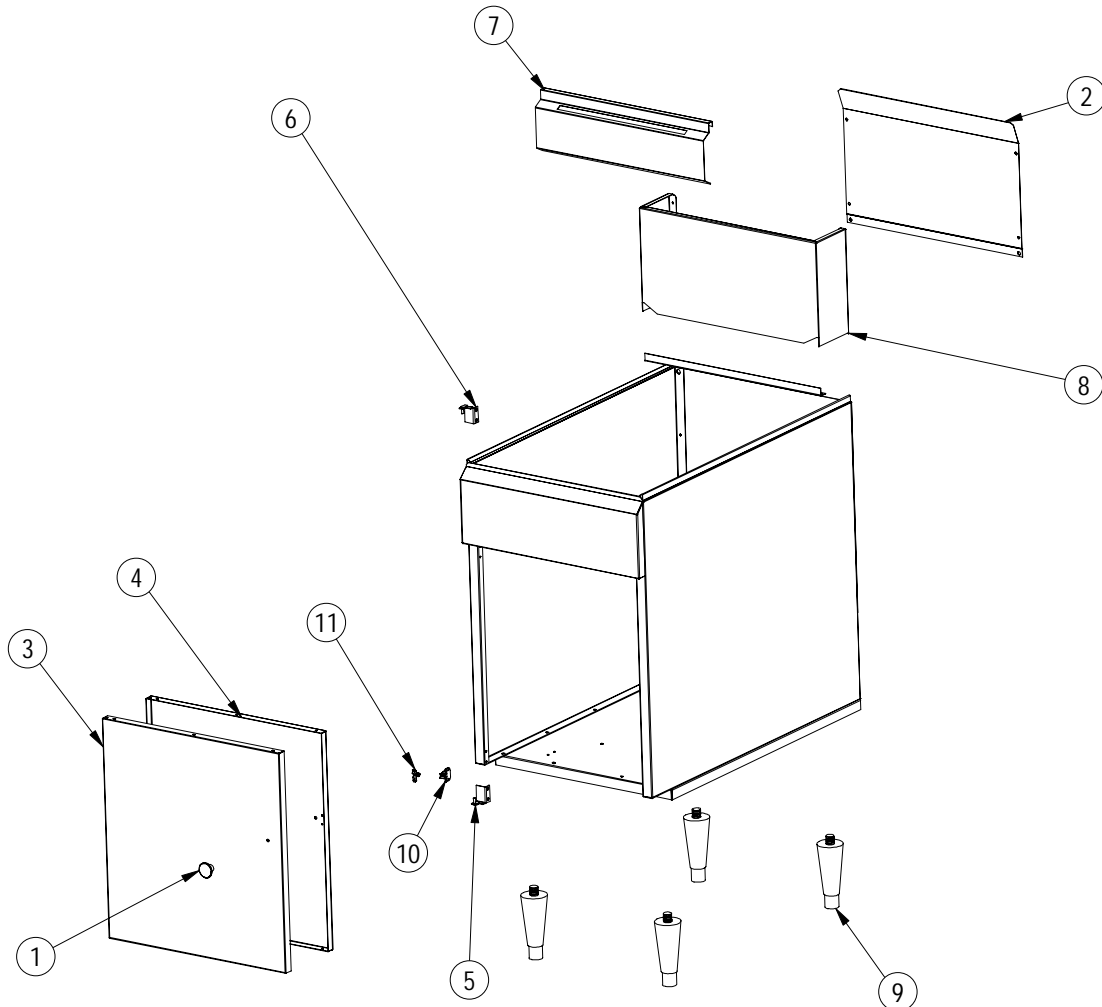

Key	Part Number	Qty	Description
1	1-2849	1	Knob, Door
2	1182246	1	Cover Flue Rear
3	1182228	1	Door
4	1182031	1	Panel Inner Door
5	1182025	1	Bracket, Bottom Door
6	1182024	1	Bracket, Top Door Weld Assembly
7	1182008	1	Fry Panel
8	1182007	1	Splasher Weld Assembly
*	1172650	4	Leg Pad
9	1178205	1	Leg, Black (set of four)
*	1174265	1	Casters (optional, set of four)
*	1174262	1	Earthquake Legs (optional, set of four)
10	1164133	1	Catch, Door
11	1164132	1	Door Striker

\* not shown on drawing.

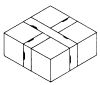

<b>Gas Train Parts for GFS35</b>			
See drawing on following page.			
Key	Part Number	Qty	Description
1	P5239-4	1	Union, Black, 1/2"
2	1182155	3	Burner, Fryer, 6 inch
3	1182154	1	Thermopile
4	1182152	1	Valve, Combination, Natural Gas
	1182153	1	Valve, Combination, LP Gas
5	1182151	1	Thermostat, Regulating
6	1182150	1	Thermostat, Limiting
7	1182508	1	Bracket, Support
8	1182055	1	Bracket, Manifold Support
9	1182047	1	Tubing Lower Pilot
10	1182040	3	Orifice, Main, Natural Gas (#36)
	1182043	3	Orifice, Main, Propane (#52)
11	1182034	3	Fitting, Gas Orifice
12	1182028	1	Tube, Upper Pilot
13	1182018	1	Tube Flex Gas
14	1182014	1	Manifold, 3 Burner
15	1175216	1	Nipple, 1/2 x 4-1/2, Black
16	1147007	1	Plug, Pipe Black. 1/8
17	1146909	2	Elbow, St. Black., 1/2" 90 Deg
18	1146806	1	Nipple, Pipe, Close, Black, 1/2 Inch
19	1061298	1	Union, Brass
20	1054197	1	Pilot Assembly, 0.018, Natural Gas
*	1054111	1	Pilot Orifice, Propane (0.011", orifice only)
21	1036604	3	Nut Air Collar
*	4440493	1	Natural-to-LP Gas Conversion Kit
* not shown on drawing.			

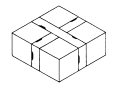

### Gas Train Parts for GFS35

See parts list on previous page.

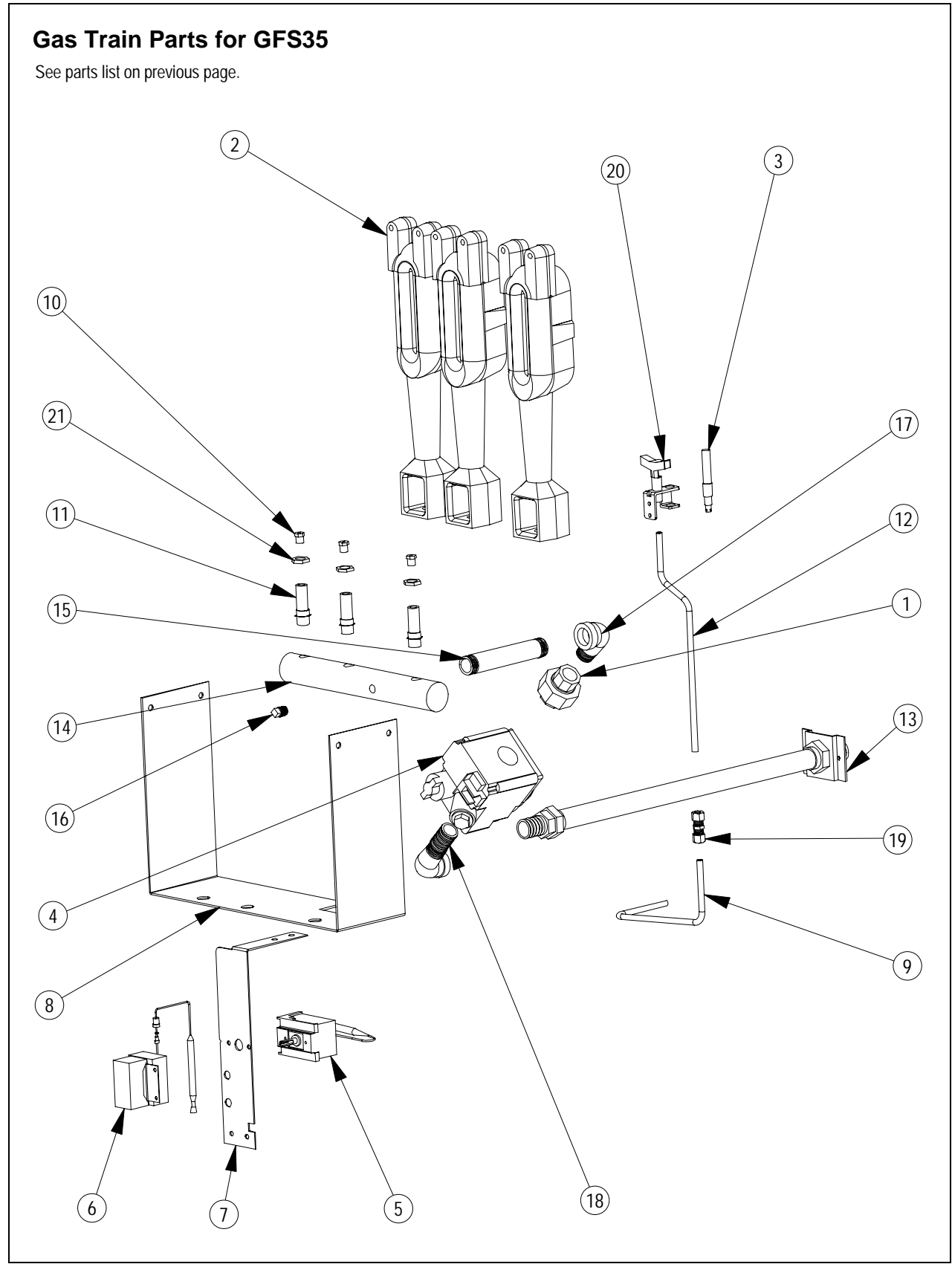

PARTS





**Gas Train Parts for GFS45**

See drawing on following page.

Key	Part Number	Qty	Description
1	P5239-4	1	Union, Black, 1/2"
2	1182237	1	Manifold, 4 Burner
3	1182155	4	Burner, Fryer, 6 Inch
4	1182154	1	Thermopile
5	1182152	1	Valve, Combination, Natural Gas
	1182153	1	Valve, Combination, LP Gas
6	1182151	1	Thermostat, Regulating
7	1182150	1	Thermostat, Limiting
8	1182058	1	Bracket, Support
9	1182056	1	Bracket, Manifold Support
10	1182047	1	Tubing Lower Pilot
11	1182040	4	Orifice, Main, Natural Gas (#36)
	1182043	4	Orifice, Main, Propane (#52)
12	1182034	4	Fitting, Gas Orifice
13	1182028	1	Tube, Upper Pilot
14	1182018	1	Tube Flex Gas
15	1175216	1	Nipple, 1/2 x 4-1/2, Black
16	1147007	1	Plug, Pipe Black. 1/8
17	1146909	2	Elbow, St. Black., 1/2" 90 Deg
18	1146806	1	Nipple, Pipe, Close, Black, 1/2 Inch
19	1061298	1	Union, Brass
20	1054197	1	Pilot Assembly, 0.018, Natural Gas
*	1054111	1	Pilot Orifice, Propane (0.011", orifice only)
21	1036604	4	Nut Air Collar
*	4440493	1	Natural-to-LP Gas Conversion Kit

\* not shown on drawing.



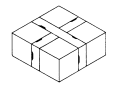

### Gas Train Parts for GFS45

See parts list on previous page.

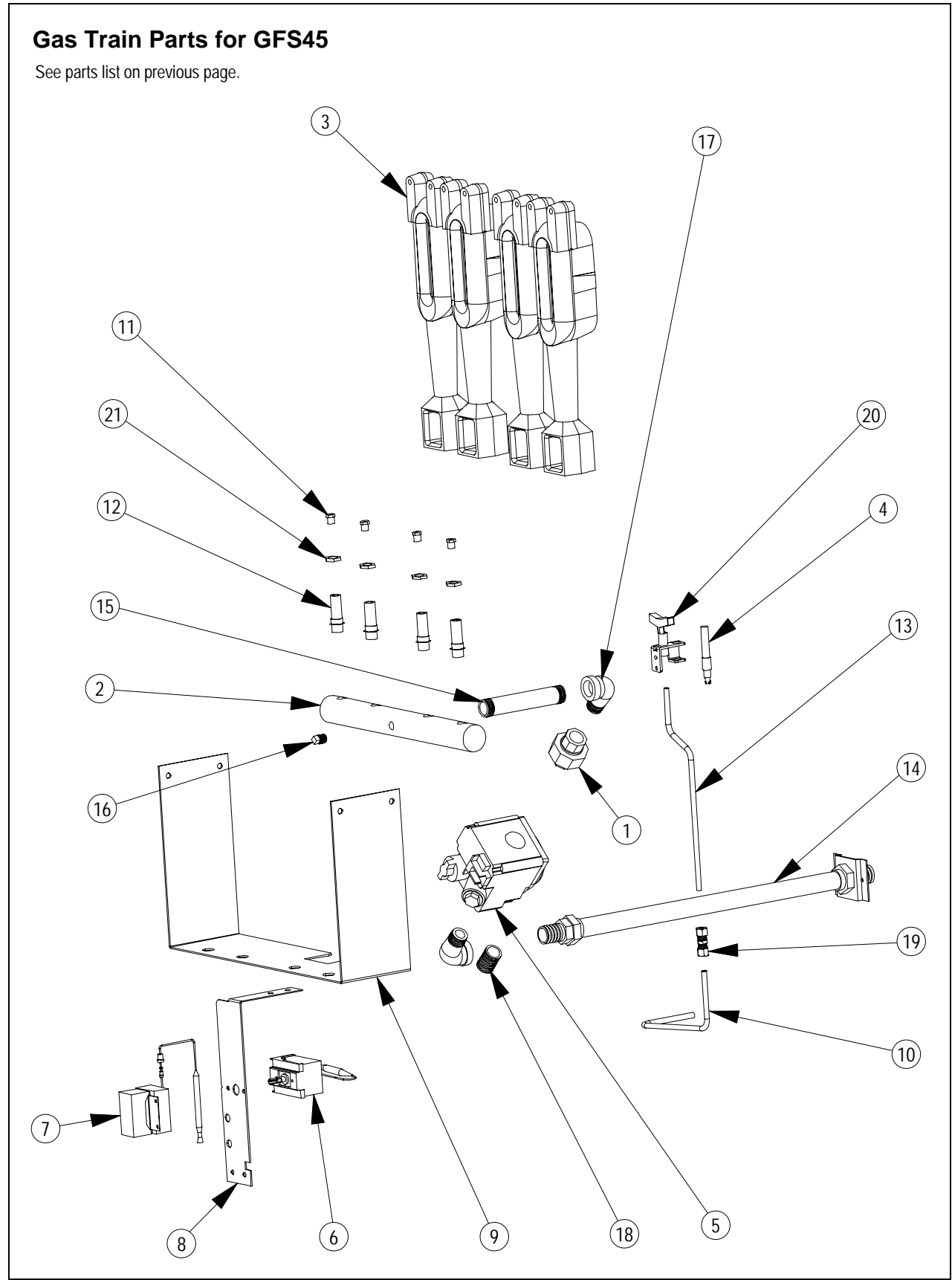

PARTS





**Gas Train Parts for GFS65**

See drawing on following page.

Key	Part Number	Qty	Description
1	P5239-4	1	Union, Black, 1/2"
2	1182243	1	Manifold, 5 Burner
3	1182155	5	Burner, Fryer, 6 Inch
4	1182154	1	Thermopile
5	1182152	1	Valve, Combination, Natural Gas
	1182153	1	Valve, Combination, LP Gas
6	1182151	1	Thermostat, Regulating
7	1182150	1	Thermostat, Limiting
8	1182058	1	Bracket, Support
9	1182057	1	Bracket, Manifold Support
10	1182047	1	Tubing Lower Pilot
11	1182040	5	Orifice, Main, Natural Gas (#36)
	1182043	5	Orifice, Main, Propane (#52)
12	1182034	5	Fitting, Gas Orifice
13	1182028	1	Tube, Upper Pilot
14	1182018	1	Tube Flex Gas
15	1175216	1	Nipple, 1/2 x 4-1/2, Black
16	1147007	1	Plug, Pipe Black. 1/8
17	1146909	2	Elbow, St. Black., 1/2" 90 Deg
18	1146806	1	Nipple, Pipe, Close, Black, 1/2 Inch
19	1061298	1	Union, Brass
20	1054197	1	Pilot Assembly, 0.018, Natural Gas
*	1054111	1	Pilot Orifice, Propane (0.011", orifice only)
21	1036604	5	Nut Air Collar
*	4440493	1	Natural-to-LP Gas Conversion Kit

\* not shown on drawing.



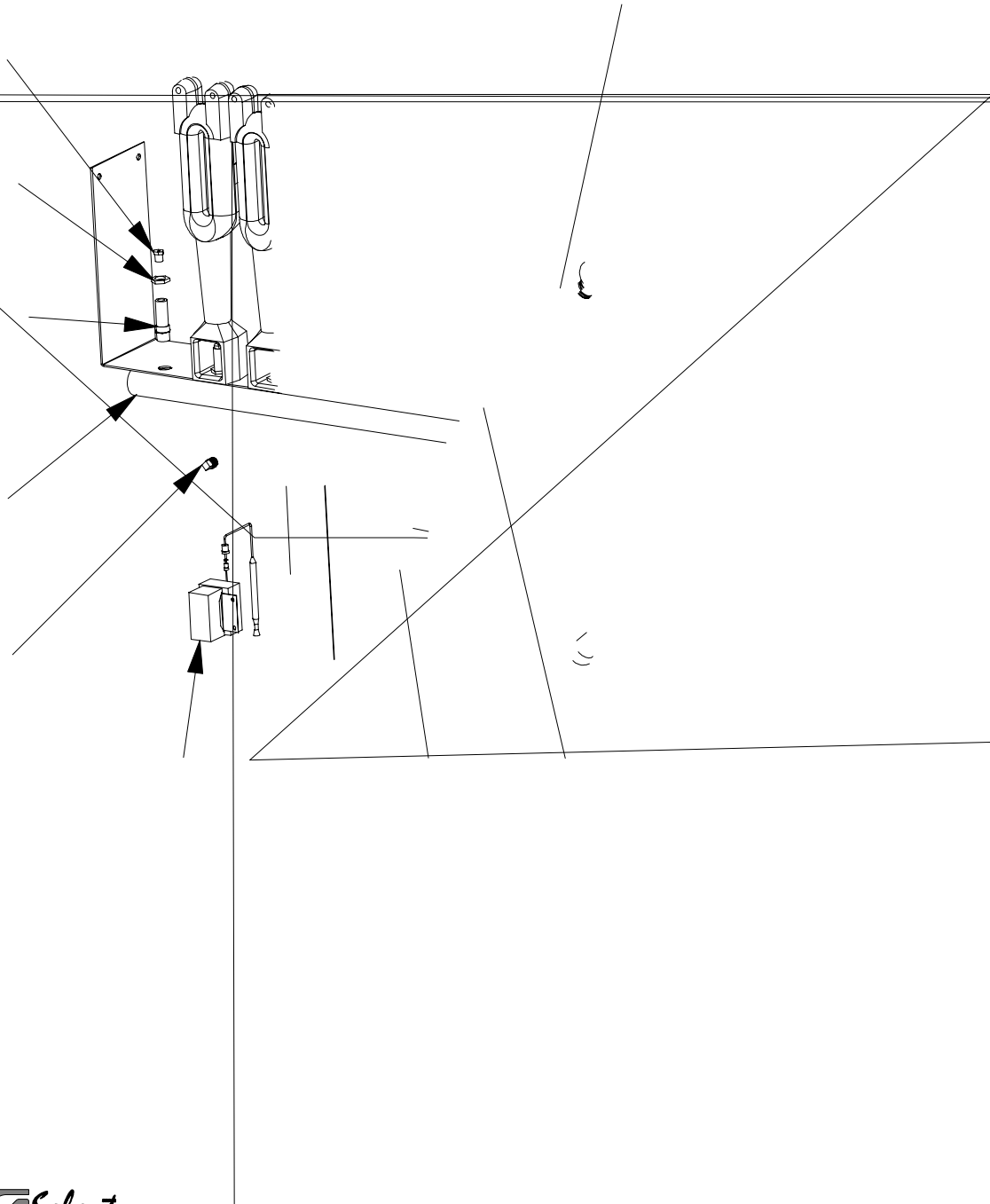
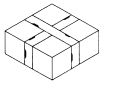

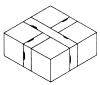

Frypot Parts for GFS35

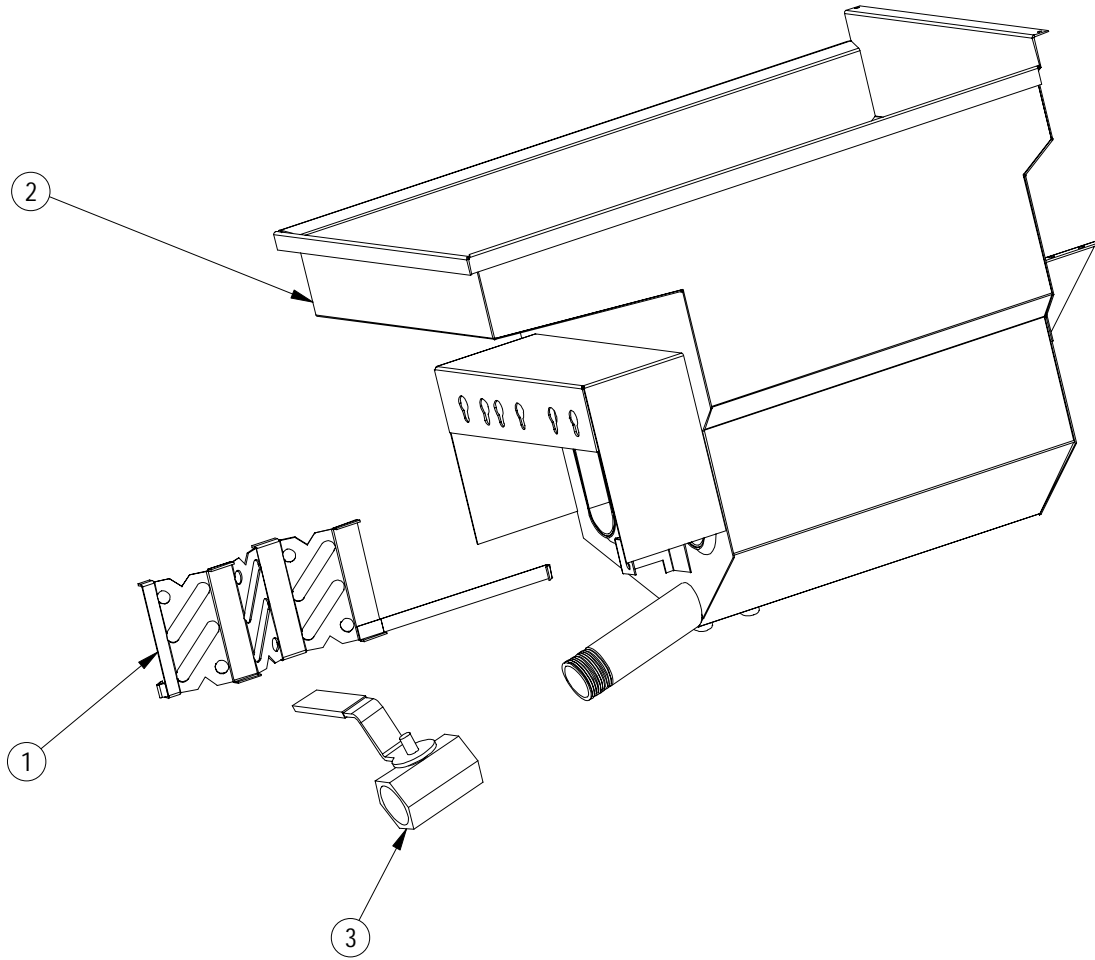

Key	Part Number	Qty	Description
1	1182262	3	Baffle Weld Assembly
2	1182258	1	Frypot Weld Assembly
3	1182238	1	Valve, Ball, 1-1/4 in
*	1036618	1	Thermostat Bulb Clamp
*	1140700	1	Screen, Tube Covering
*	P9181	2	Basket, Single
*	1176845	1	Drain Pipe Extension
*	1176846	1	Clean Out Rod (optional)

\* not shown on drawing.

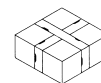

**Frypot Parts for GFS45**

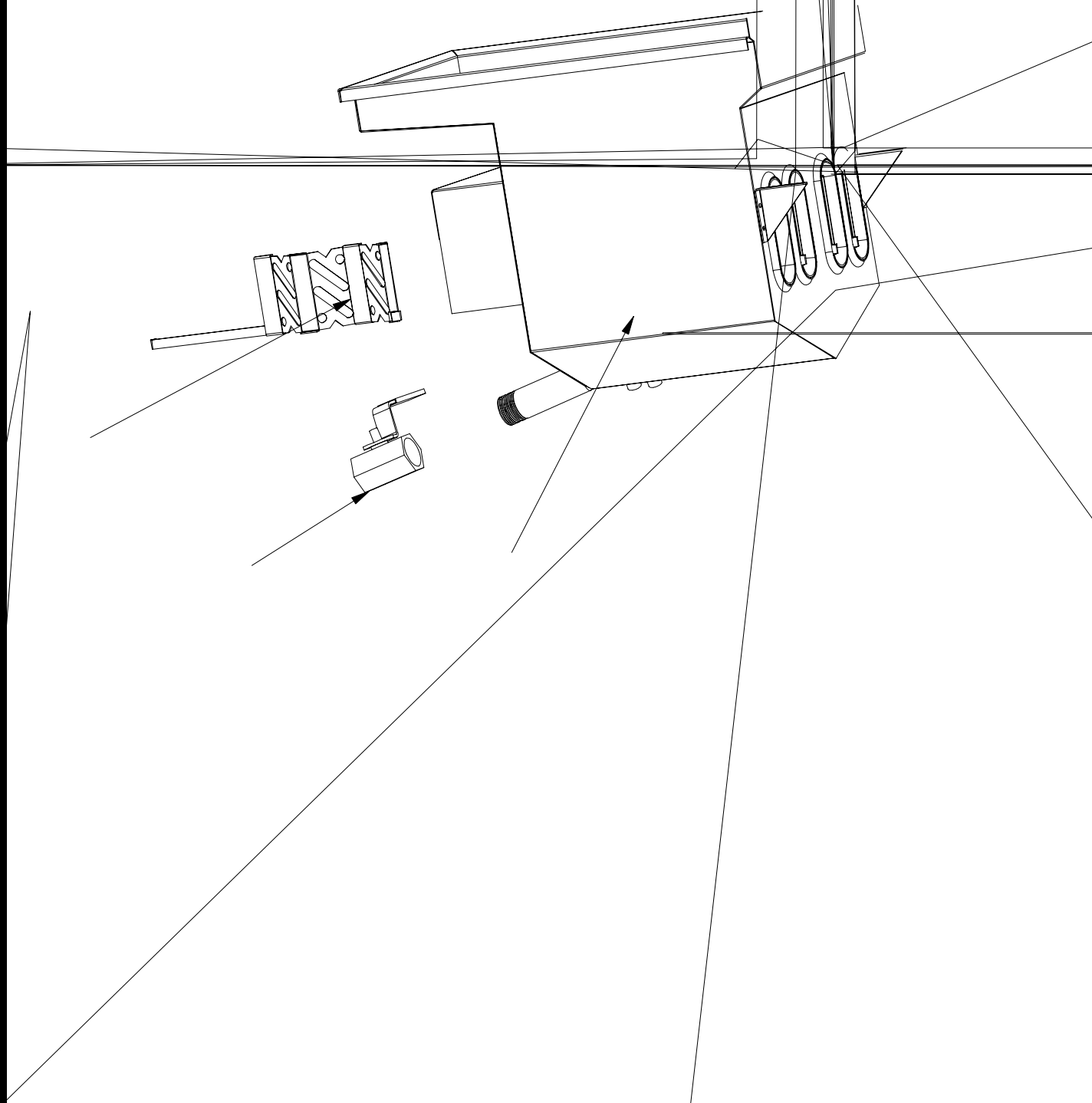

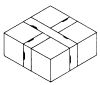

Frypot Parts for GFS65

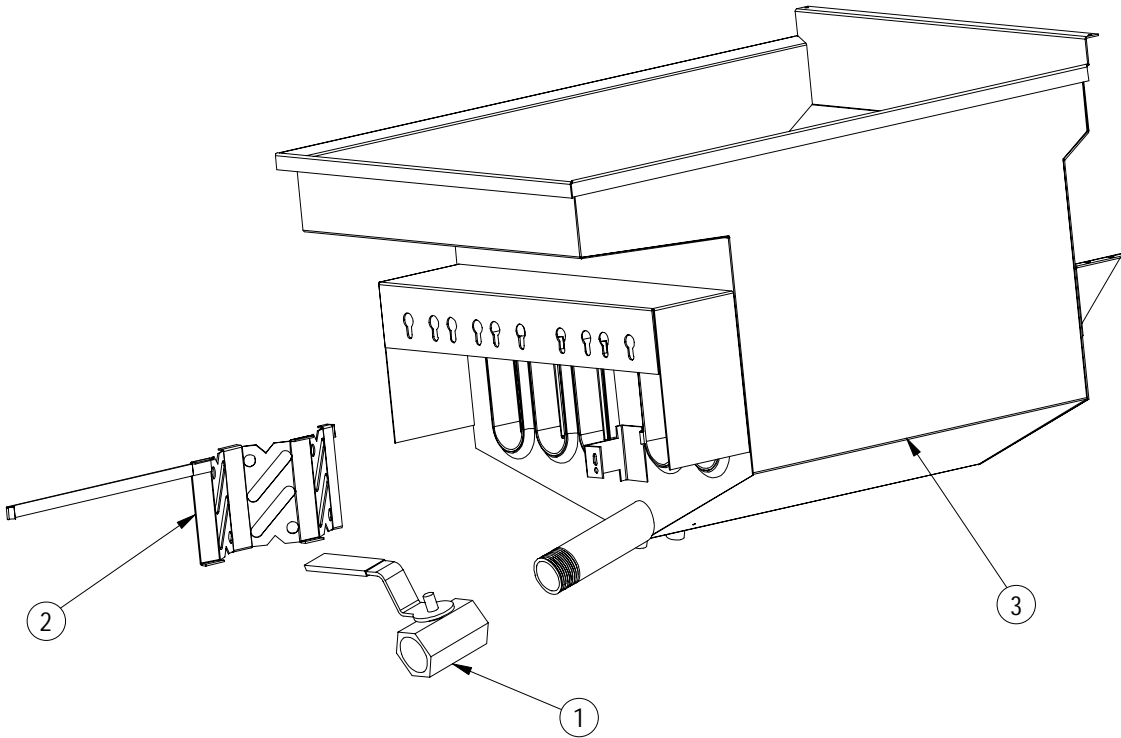

Key	Part Number	Qty	Description
1	1182238	1	Valve, Ball, 1-1/4 in
2	1182021	5	Baffle Weld Assembly
3	1182005	1	Frypot Weld Assembly
*	1036618	1	Thermostat Bulb Clamp
*	1140701	1	Screen, Tube Covering
*	P9183	2	Basket, Single
*	1176845	1	Drain Pipe Extension
*	1176846	1	Clean Out Rod (optional)

\* not shown on drawing.

GFS SERIES TUBE FRYERS



# FREE-STANDING, FLOOR MODEL GFS SERIES TUBE FRYERS

A product with the Southbend name incorporates the best in durability and low maintenance. We all recognize, however, that replacement parts and occasional professional service may be necessary to extend the useful life of this unit. When service is needed, contact a Southbend Authorized Service Agency, or your dealer. To avoid confusion, always refer to the model number, serial number, and type of your unit.



Southbend  
1100 Old Honeycutt Road, Fuquay-Varina, NC 27526  
(800) 348-2558 or (919) 552-9161 • FAX (800) 348-2558 or (919) 552-9798