

morphy richards®



Register online for your 2 year guarantee. See back of this instruction book for details.
(UK and Ireland customers only)
www.morphyrichards.co.uk



Deep Fat Fryer



Please read and keep these instructions

Getting the best from your new fryer...

*Do not attempt to move the fryer while it is still hot
- wait three hours after frying for your fryer to cool.*



DF45040 MUK Rev2

If you have a problem or complaint, please call our dedicated UK based helpline before returning your product to the retailer from where it was purchased.



UK Helpline: 0844 871 0952
Replacement Parts: 0844 873 0718
Ireland Helpline: 1800 409 119



For details of other Morphy Richards products, plus replacement parts and accessories, please see our website:

www.morphyrichards.com



IMPORTANT SAFETY INSTRUCTIONS

The use of any electrical appliance requires the following common sense safety rules.

Primarily there is danger of injury or death and secondly the danger of damage to the appliance. These are indicated in the text by the following two conventions:

WARNING: Danger to the person!

IMPORTANT: Damage to the appliance!

In addition we offer the following safety advice.

Your safety

- **WARNING:** Never attempt to move your fryer until it is completely cool. This can take up to three hours.
- **WARNING: To protect against the risk of electric shock, do not immerse the fryer body in water or other liquid.**
- Unplug from the electrical outlet when not in use and before cleaning. Allow to cool before putting on or taking off parts, and before cleaning the appliance.
- Never leave the fryer unattended when connected to the electricity supply.
- Never lean over the fryer when it is in use.
- When opening the lid, stand back as some hot steam may be released.
- Always use oven gloves when removing or replacing lid during use.
- Be careful not to touch those surfaces of the fryer which become hot when in use.

- This appliance is not intended for use by persons (including children) with reduced physical, sensory or mental capabilities, or lack of experience and knowledge, unless they have been given supervision or instruction concerning use of the appliance by a person responsible for their safety.

Product safety

- The fryer body must never be immersed in water.
- When unpacking the fryer, make sure all packing material is removed.
- Never connect the fryer to the electricity supply without oil in the tank.
- Never operate with the oil level below minimum mark (2.0 litres) or above maximum mark (2.2 litres).

Location

- This appliance is intended to be used in household and similar applications such as:

farm houses;

by clients in hotels, motels and other residential type environments;

bed and breakfast type environments.

It is not suitable for use in staff kitchen areas in shops, offices and other working environments.

- Place the appliance on a horizontal, flat and stable surface, away from a heating source and where it cannot be splashed by water.
- Allow adequate air space above and on all sides for air circulation.
- Do not use your fryer under cupboards or shelves.

- Do not use outdoors or near water.
- Do not use your fryer near or below combustible material, such as curtains.

Other safety considerations

- The use of attachments or tools not recommended or sold by Morphy Richards may cause fire, electric shock or injury.
- Do not operate any appliance with a damaged cord or plug or after the appliance malfunctions or has been damaged in any manner. Telephone the helpline number (the telephone number can be found on the front cover) for advice on examination and repair.
- Do not use the fryer for anything other than it's intended purpose.
- Always dry food before frying, e.g. chips which are too wet, as they can cause the hot oil to froth excessively.
- This appliance is not intended to be operated by means of an external timer or a separate remote control system.

Children

- Never allow a child to operate this appliance. Teach children to be aware of dangers in the kitchen, warn them of the dangers of reaching up to areas where they cannot see properly or should not be reaching.
- Children do not understand the dangers associated with operating electrical appliances. Never allow children to use this appliance.
- Children should be supervised to ensure that they do not play with the appliance.



Scalds

- Run cold water over the affected area immediately. Do not stop to remove clothing. Seek medical help immediately.

Mains cable

- The mains cable should reach from the socket to the base unit without straining the connections.
- Do not let the cable hang over the edge of the table or the counter and keep it away from any hot surface.
- Do not let the cable run across an open space e.g. between a lower socket and table.
- If the supply cable is damaged, it must be replaced by the manufacturer, its service agent or a similarly qualified persons in order to avoid a hazard.

ELECTRICAL REQUIREMENTS

Check that the voltage on the rating plate of your appliance corresponds with your house electricity supply which must be A.C. (Alternating Current).

If the socket outlets in your home are not suitable for the plug supplied with this appliance, the plug should be removed and the appropriate one fitted.

WARNING: The plug removed from the mains cable, if severed must be destroyed, as a plug with a bared flexible cord is hazardous if engaged into a live socket outlet.

Should the fuse in the 13 amp plug require changing, a 13 amp BS1362 fuse must be fitted.

WARNING: This appliance must be earthed.

FEATURES

- 1 Viewing window
- 2 Top cover
- 3 Handle lock
- 4 Handle
- 5 Top Cover Plate
- 6 Filter
- 7 Frying basket
- 8 Oil reservoir
- 9 Lid release button
- 10 Adjustable thermostat
- 11 Indicator light
- 12 Switch

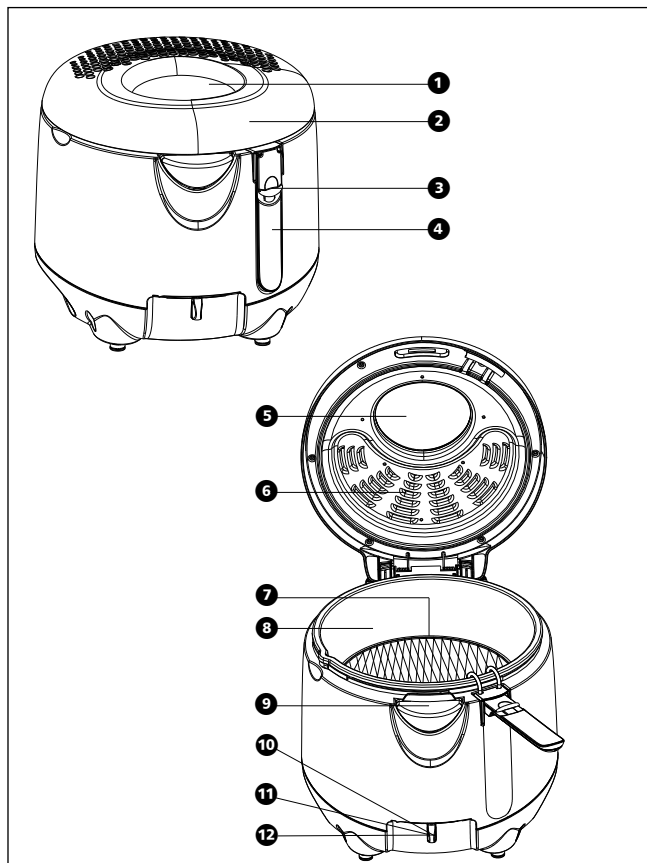

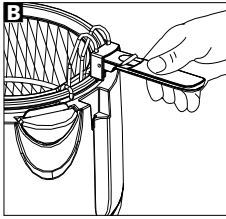
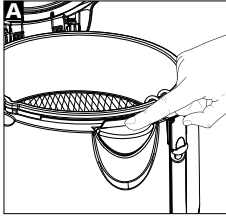

BEFORE FIRST USE

Refer to the assembly sequence on this page.

When unpacking the fryer, make sure all packaging material is removed.

WARNING: make sure that your fryer is disconnected from the electricity supply.

Remove the frying basket and lid, and wash these by hand in hot soapy water. Please note: do not leave in water to soak for a long period of time.

Dry all parts of your fryer thoroughly and replace the basket and lid.

(Please follow the cleaning instructions).

WARNING: Do not immerse the main unit in water.

OPERATION

Lid operation

Press the lid release button down and in, the lid is spring loaded and will rise up on it's own **A**.

In the upper position, the lid will lift out of it's guides at the back for easy cleaning. To replace, locate in the guides and slide back into position.

Close the lid by pressing down in the centre and ensure the locking catch is fully engaged.

Basket operation

Pull the basket handle to the horizontal position and hook over the tank to raise the basket **B**.

Location of basket to drain

The basket can be raised into the rest/drain position or removed completely.

Take the basket out of the fryer and place the required amount of food in the basket. (Refer to page 7 for quantities).

Lift the basket back into the rest/drain position, then close the lid.

Assembly / Disassembly sequence

The fryer has to be disassembled and assembled following this procedure.

- Open the lid and remove.
- Remove the basket.

Assembly is the reverse of the above process.

FILLING WITH OIL

Pour oil into the tank up to the maximum level indicated (approximately 2.2 litres of oil).

Lightly smear the inside of the viewing window with the oil to inhibit any condensation which could reduce visibility.

- Use good quality liquid vegetable oil, see getting the best from your fryer on page 5.

COOKING

WARNING: Never operate the fryer without oil in the bowl.

- 1 Lower the basket and close the lid.
- 2 Plug into the mains and switch the power on at the socket.
- 3 Adjust the adjustable thermostat from the off position to the required temperature.
- 4 The orange temperature light will illuminate.

- 5 Set the variable temperature control to the required setting, see 'frying times and temperature section'.
- 6 The fryer is now pre-heating the oil, the orange temperature light may go out and come back on once or twice during pre-heat. After approximately 15 minutes, the oil will be at the correct temperature.
- 7 Lift the lid.
 - Do not over fill the basket when frying, the food must be covered with the bubbling hot oil.

There are two methods of cooking in your fryer; one general method for most food types and another for home battered products.

General cooking method (with the basket)

- 1 Place the basket in the raised position. The basket should always be in the raised position when it is to be filled with food.
- 2 Place the food, which should be as dry as possible, into the raised basket. When frying frozen food, avoid adding ice particles to the hot oil. Remove the basket from the fryer, add the frozen food and shake the basket to remove excess ice and frost. The oil temperature and oil life expectancy will be improved.
- 3 Lower the basket onto the basket rest.
- 4 Lower the lid.
- 5 Lower the basket to the frying position.
 - You can observe the cooking process by raising the lid or looking through the viewing window to observe progress.
- 6 When the food is cooked, raise the lid, lift the basket out of the oil, give it a shake, and place it in its raised rest position for one minute to drain.

- 7 Lift the basket out and shake the fried food into a dish with oil absorbing kitchen paper.
- 8 Turn the adjustable thermostat to the off position after use.
- 9 After use, disconnect from the mains supply and allow to cool. Wipe any spilt oil from the fryer body.
 - You can store the basket in the oil.

Cooking home-battered foods (with the basket in lowered position)

This method allows for the fact that if wet batter is placed in the basket prior to cooking, the food may stick.

- 1 Leave the basket in the down position.
- 2 Coat the raw food in the batter and allow it to drain slightly to get rid of the excess coating.
- 3 Very carefully, slowly lower the coated food into the hot oil, using a suitable implement or tongs. This allows the batter to become solid and prevents it sealing to the mesh of the basket.

WARNING: Take care as the oil may spit as the food is added.

GETTING THE BEST FROM YOUR FRYER

Oil

- Always ensure that you use good quality oil for deep frying. We recommend liquid vegetable oils, alternatively use corn, groundnut or rapeseed oil. Avoid mixing oils of different types and quality.
- Solid fat (lard) and solid oil can be used, this should be first melted in a pan until softened, then carefully transferred into the fryer bowl.



- Change the oil when it becomes brown or cloudy in colour, usually after frying 15 times.
- **IMPORTANT:** Do not switch the fryer on until the fryer bowl is filled with oil or solid oil or lard.

Cooking

- Your food must always be completely dry in order to avoid overflowing, to prolong the use of the oil and to give a crisper finish to the food.
- Pieces of food should be of the same size and thickness.
- As a general guide, pre-cooked foods need a higher cooking temperature than raw foods.
- Do not overload the basket as it may cause a drop of temperature that may leave the food greasy.
- Cook your food thoroughly. Remember that your food may begin to turn golden brown before it is cooked through.
- Avoid leaving food to drain for too long in the basket as the food may become soft and lose its crunchiness.
- Select your cooking utensils with care. Do not use utensils that may melt. Metal utensils become hot and therefore should have insulated handles. When using metal utensils, take care not to damage the non-stick coating of the bowl.
- All foodstuffs contain moisture. When lowered into the hot oil, the water turns to steam. Most of the steam escapes harmlessly through the lid vent, but trapped steam may escape when opening the lid - so care is needed.

Chips

- Old potatoes are ideal for making chips. Your chips should be evenly sized so that they cook evenly. They should be rinsed in a colander under a cold tap and dried using a kitchen towel or absorbent paper. For best results, fry your chips for 10-12 minutes, shaking the basket at intervals to ensure chips get an overall browning.
- Whilst the frying times on page 7 state the maximum capacity for chips, for best results, we recommend no more than 700g of frozen chips or 900g of fresh chips are fried.

Emptying and cleaning

WARNING: Cleaning should only be carried out with the plug removed from the socket. The fryer should have completely cooled. Allow 3 hours for cooling.

- 1 Remove the lid.
- 2 Remove the basket.
- 3 Pour out the oil through fine muslin or absorbent paper placed in a suitable funnel into a container.
- 4 Wash the lid, basket, handle and the inside of the tank by hand with hot soapy water.
- The lid can be washed in a dishwasher. However, prolonged dishwasher use could discolour the lid.
- The basket should NOT be washed in a dishwasher.
- 5 Clean the body of the fryer with a warm moistened cloth, washing up liquid can be used.
- 6 Dry all parts of your fryer thoroughly and reassemble all parts. Refer to the assembly sequence.



- The outside of the bowl is not non-stick coated, if care is taken, it is unlikely to become dirty. If oil does drip down the exterior when the oil is being emptied out, make sure that it is hand washed thoroughly. The exterior may appear discoloured, this is quite normal and will not detract from the performance of the fryer.
- 7 Place the basket back into the tank.

FRYING TIMES AND TEMPERATURE CHART

These frying times are intended as a guide only and should be adjusted to suit quantity or thickness of food and your own taste. Times listed are normally the maximum time required.

Fresh cut chips
900g
190°C 10-12 min

Frozen chips
700g
190°C 12-15 min

Fresh cod or haddock
300g/400g (2 or 3 pieces)
190°C 8-10 min

Frozen cod or haddock
300g/400g
170°C 10-15 min

Frozen plaice
1x 150g piece
190°C 5-6 min

Whitebait
190°C 1-2 min
Just enough to cover the base of the basket.

Scampi fresh in crumbs
170°C 2-3 min
Just enough to cover the base of the basket.

Scampi frozen in crumbs
170°C 3-5min
Just enough to cover the base of the basket.

Beef burgers*
150°C/170°C 4-6 min
2oz/55g (4 pieces)
4oz/110g 5-10min
(2 pieces)

Fresh or defrosted chicken portions in crumbs*
2x 200g pieces
170°C 20-25 min

Frozen chicken portions in crumbs*
2x 200g pieces
170°C 25-30 min

Mushrooms
200g
190°C 2-3 min

Weights stated are the maximum advised.

*Chicken and beef burgers taint the oil, leaving a taste you may not want when frying other foods, if so, change the oil.

HELPLINE

If you have any difficulty with your appliance, do not hesitate to call. We are more likely to be able to help than the store from where you bought it.

Please have the following information ready to enable our staff to deal with your enquiry quickly:

- Name of the product.
- Model number as shown on the underside of the appliance.
- Serial number as shown on underside of the appliance.

UK Helpline
0844 871 0952

Replacement Parts
0844 873 0718

Ireland Helpline
1800 409 119

Website

You may also contact us through our website, or visit the site to browse and purchase appliances, spare parts and accessories from the extensive Morphy Richards range.

www.morphyrichards.com



REGISTERING YOUR TWO YEAR GUARANTEE

Your standard one year guarantee is extended for an additional 12 months when you register the product within 28 days of purchase with Morphy Richards. If you do not register the product with Morphy Richards within 28 days, your product is guaranteed for 1 year. To validate your 2 year guarantee register with us online at www.morphyrichards.co.uk

N.B. Each qualifying product needs to be registered with Morphy Richards individually.

Please note that the 2 year guarantee is only available in the UK and Ireland. Please refer to the one year guarantee for more information.

YOUR ONE YEAR GUARANTEE

It is important to retain the retailer's receipt as proof of purchase. Staple your receipt to this back cover for future reference.

Please quote the following information if the product develops a fault. These numbers can be found on the base of the product.

Model no.

Serial no.

All Morphy Richards products are individually tested before leaving the factory. In the unlikely event of any appliance proving to be faulty within 28 days of purchase, it should be returned to the place of purchase for it to be replaced.

Morphy Richards products are intended for household use only. See usage limitations within the location safety instructions.

Morphy Richards has a policy of continuous improvement in product quality and design. The company, therefore reserves the right to change the specification of its models at any time.

If the fault develops after 28 days and within 12 months of original purchase, you should contact the Helpline number quoting Model number and Serial number on the product, or write to Morphy Richards at the address shown.

You may be asked to return a copy of proof of purchase.

Subject to the exclusions set out below (see Exclusions), the faulty appliance will then be repaired or replaced and dispatched usually within 7 working days of receipt.

If, for any reason, this item is replaced during the 1 year guarantee period, the guarantee on the new item will be calculated from original purchase date. Therefore it is vital to retain your original till receipt or invoice to indicate the date of initial purchase.

To qualify for the 1 year guarantee, the appliance must have been used according to the instructions supplied. For example, crumb trays should have been emptied regularly.

EXCLUSIONS

Morphy Richards shall not be liable to replace or repair the goods under the terms of the guarantee where:

- 1 The fault has been caused or is attributable to accidental use, misuse, negligent use or used contrary to the manufacturer's recommendations or where the fault has been caused by power surges or damage caused in transit.
- 2 The appliance has been used on a voltage supply other than that stamped on the products.

3 Repairs have been attempted by persons other than our service staff (or authorised dealer).

4 The appliance has been used for hire purposes or non domestic use.

5 The appliance is second hand.

6 Morphy Richards are not liable to carry out any type of servicing work, under the guarantee.

7 Plastic filters for all Morphy Richards kettles and coffee makers are not covered by the guarantee.

8 Batteries and damage from leakage are not covered by the guarantee.

- This guarantee does not confer any rights other than those expressly set out above and does not cover any claims for consequential loss or damage. This guarantee is offered as an additional benefit and does not affect your statutory rights as a consumer.



For electrical products sold within the European Community. At the end of the electrical products useful life, it should not be disposed of with household waste. Please recycle where facilities exist. Check with your Local Authority or retailer for recycling advice in your country.

morphy richards

**The After Sales Division
Morphy Richards Ltd**
Mexborough, South Yorkshire,
England, S64 8AJ

Helplines (office hours)
UK 0844 871 0952
Spare Parts 0844 873 0718
Republic of Ireland 1800 409 119

DF45040 MUK Rev2 01/10

For details of other Morphy Richards products, plus replacement parts and accessories, please see our website:

www.morphyrichards.com

