



kitchen think

Instructions for Installation and Use

**Deep Fat Fryer
Model E3FX**

To the Installer

**Before installation fill in the product details on the back cover of this book.
The information can be found on the rating plate.**

To the User

**You must read the instructions prior to installing and using the appliance and
then retain them for future reference.**

CONTENTS

Introduction	3
For Your Safety	4
Know your Deep Fat Fryer	5
How to use your Deep Fat Fryer	5
Care and Cleaning	6
Troubleshooting	6
Installation	7
Electrical Connection	8
After Sales Service	10
Hotpoint Guarantee	11
Key Contacts	Back Cover

Retention of this Instruction Book

This Instruction Book must be kept handy for reference as it contains important details on the safe and proper use of the appliance.

If you sell or pass the appliance to someone else, or move house and leave it behind, make sure this Book is also provided so the new owner can become familiar with the appliance and safety warnings.

If the Book is lost or damaged a copy may be obtained from:
GDA LTD., Morley Way, Peterborough, PE2 9JB

Introduction

Your new 'deep fat fryer' is guaranteed* and will give lasting service. This guarantee is only applicable if the appliance has been installed in accordance with the installation instructions detailed in this booklet.

To help make best use of your cooking equipment, please read this booklet carefully.

The appliance is designed specifically for domestic use and responsibility will not be accepted for use in any other installation.

Before putting oil in the fryer for the first time, carefully clean the steel parts and the heater, to remove any residue left from manufacture.

*** The guarantee is subject to the provisions that the appliance:**

- (a) Has been used solely in accordance with this booklet.**
- (b) Has been properly connected to a suitable supply voltage as stated on the rating plate, attached to the appliance.**
- (c) Has not been subjected to misuse or accident or been modified or repaired by any person other than the manufacturers authorised employee or agent.**
- (d) Has been correctly installed.**



This appliance conforms with the following European Economic Community directives

- 73/23/EEC of 19/02/73 (Low Voltage) and subsequent modifications.
- 89/336/EEC of 03/05/89 (Electromagnetic Compatibility) and subsequent modifications.
- 93/68/EEC of 22/07/93 and subsequent modifications.

For Your Safety

When used properly your appliance is completely safe but as with any electrical product there are certain precautions that must be observed.

PLEASE READ THE BELOW PRECAUTIONS BEFORE USING YOUR APPLIANCE.

To maintain the efficiency and safety of this appliance, we recommend you do the following:

- only call the Service Centres authorised by the manufacturer.
- always use genuine spare parts.

ALWAYS:

- make sure you remove all packaging and dispose of safely.
- check the soundness of the appliance after it has been unpacked.
- make sure you understand the controls before using the appliance.
- keep children away from the appliance during use.
- take care to avoid heat/steam burns when operating the control.
- make sure the control is turned off when you have finished cooking and when not in use.
- disconnect from the power supply, and allow to cool, before cleaning or performing maintenance.
- refer servicing to a qualified appliance service engineer.
- keep the appliance clean as a build up of grease or fat from cooking can cause a fire.
- follow the basic principles of food handling and hygiene to prevent the possibility of bacterial growth.
- before putting oil into the bowl for the first time, carefully clean the steel parts and the heater, so as to remove any residue left from manufacture.
- use vegetable oil suitable for frying, we do not recommend oil from assorted seeds or sunflower oil.
- ensure there is at least the minimum 2 litres and a maximum of 2.7 litres, of oil in the bowl. Should the level drop below 2 litres during use, fresh oil must be added. It is advisable to add oil of the same type. (Maximum and Minimum measures are indicated on the bowl).
- change the oil regularly.
- if to be re-used, filter the oil before using again. Oil can be used several times, filtering removes excess deposits.
- even if oil is well filtered, small residual particles can catch fire during cooking.
- wait until the oil has reached the required temperature.
- dry food thoroughly before cooking and lower it slowly into the hot oil or fat.
- for frozen food it is advisable to defrost it at a low temperature and then fry it at a high temperature.
- note that in preparing certain dishes (fried potatoes) you will get the best results by precooking at 160°C and then subsequently cooking at 180°C.
- keep any ventilation slots clear of obstructions.

NEVER:

- attempt to install or repair the appliance without the assistance of qualified personnel.
- store items above the appliance that children may attempt to reach.
- use the appliance to heat up anything other than food.
- use the appliance as a room heater.
- dry any items on the appliance.
- install the appliance next to curtains or other soft furnishings.
- allow children to play with or tamper with the control.
- leave children unsupervised where cooking appliances are installed as all the cooking surfaces get hot during and after use.
- store chemicals, foodstuffs or pressurised containers in or on the appliance, or in cabinets immediately above or next to the appliance.
- use flammable or plastic items on or near the appliance.
- use adapters, multiple sockets and/or extension leads.
- turn on the fryer when the heater is out of the bowl.
- turn on the fryer without oil in the bowl.
- do not exceed the maximum of 2.7 litres of oil.
- fry too much food at a time, especially frozen food. This only lowers the temperature or the oil or fat too much, resulting in greasy food.
- avoid, if possible, adding salt or flavourings directly to the fryer. Quality of salt is reduced by the oil.
- pull on the appliance or the supply cable to unplug it from the electrical outlet.
- allow power cables of other appliances to come into contact with hot parts of this appliance.
- expose the appliance to atmospheric agents, such as rain or sunlight.
- operate the appliance with wet hands.
- operate the appliance when barefoot.
- allow anyone to sit or stand on any part of the appliance.
- leave anything on the surface when unattended and not in use.

Know your Deep Fat Fryer

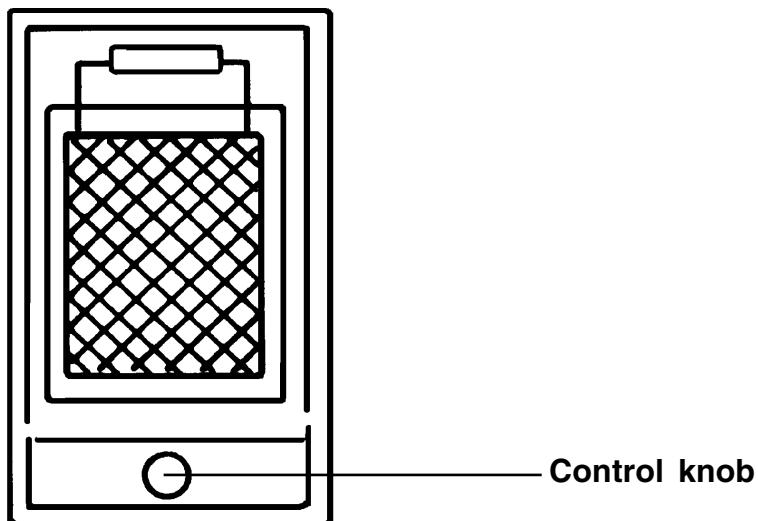

How To Use Your Deep Fat Fryer

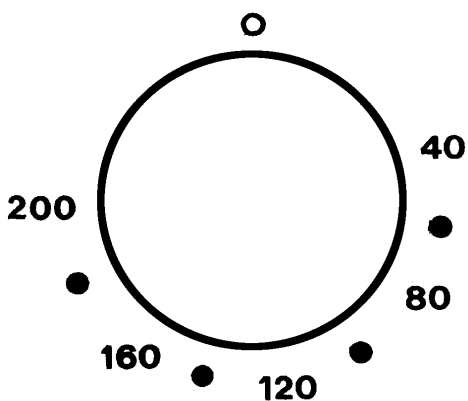

Using the control knob on the front panel you can set the temperature from 40°C to 200°C.

An indicator light comes on to show it is heating. This light will go out when the required temperature is reached.

A second light will come on when the fryer is switched on.

The fryer is equipped with a main thermostat that constantly maintains the temperature of the oil. A safety thermostat will automatically come into operation if the main thermostat fails - thus preventing the oil reaching too high a temperature, about 220°C.

The fryer is very simple to use as long as all points in the 'For Your Safety' section (page 4) are followed.

Return the control knob to 0 to turn off.

Care and Cleaning

Regular cleaning is recommended, to prolong the life of the fryer and to prevent the risk of fire.

Before cleaning or performing any cleaning or maintenance, disconnect the appliance from the power supply. Check that all controls are in the OFF position, '0', before reconnecting.

NEVER USE: Washing powder, harsh abrasive, scouring pads, aerosol cleaners or oven chemical cleaners of any kind.

Cleaning materials to avoid

- Household abrasive powders, eg. Vim.
- Oven chemical cleaners, aerosols and oven pads - Caustic cleaners such as these will etch the surface and attack the metal frame.
- Bath and sink cleaners may mark the surface.

The steel and/or painted parts must be cleaned using suitable products which are neither abrasive nor corrosive.

Avoid products based on chlorine (bleach etc.).

Avoid leaving acids or alkalis on the work surface (vinegar, salt, lemon juice etc.).

Wipe over the control knobs with a soft cloth wrung out in warm soapy water, or mild non-abrasive. Then, after wiping with a cloth wrung out in clear water, dry with a soft clean cloth.

Troubleshooting

Before calling service for assistance, check through the following list, there may be nothing wrong.

Nothing works.

Check to make sure that:

- the mains wall switch is switched on.
- try re-setting the safety thermostat:
 - remove the oil bowl.
 - unscrew the safety plug.
 - press the button.

If, despite all of these checks, the appliance does not function properly and problem persists, call Hotpoint Service (see KEY CONTACTS, back page), informing them of:

- The type of problem.
- The abbreviation used to identify the model (Mod. ...) as indicated on the warranty.

IMPORTANT:

Never call upon technicians not authorized by the manufacturer, and refuse to accept spare parts that are not original.

Installation

These instructions are intended for the qualified technician installing the appliance in order to insure that the installation, adjustments and maintenance procedures are performed correctly and comply with the regulations currently in effect.

Important: the appliance must be disconnected from the power supply before making any adjustments or performing any maintenance, etc.

The appliance is Type Y and therefore can be installed alongside of cabinets which are higher than the surface of the worktop. The following precautionary measures should be observed in order to ensure proper installation:

- a) Hoods must be installed in compliance with the required specifications contained in the instruction manual for the hood itself.
- b) The appliance can be installed on any counter top as long as it is 600 mm or more in width and resistant to temperatures of up to 100°C. The dimensions and the position of the hole are shown below.

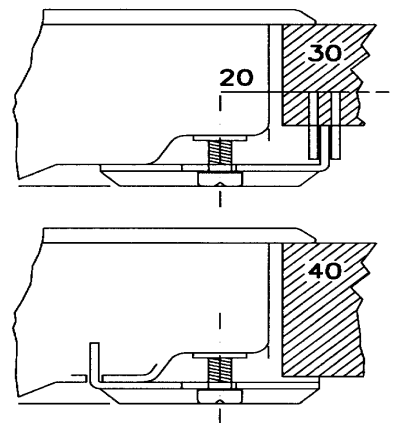
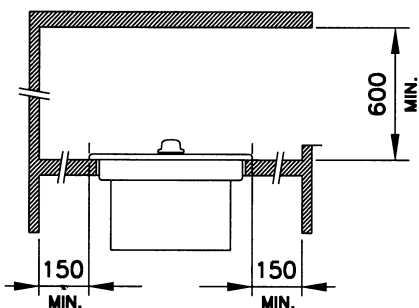
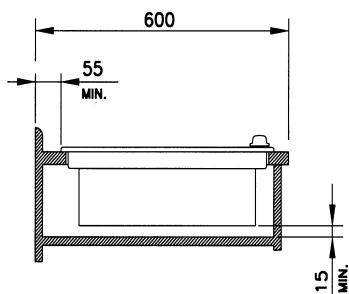
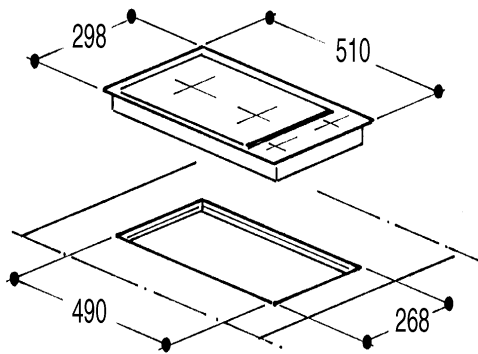

These measurements must absolutely be observed in so far as improper installation can cause the surrounding surface areas to overheat. It is recommended that the appliance be installed at a distance of at least 55 mm from the back wall or other vertical surfaces to ensure that the air circulates properly over the cooking area and to avoid overheating the surrounding surfaces. A seal or gasket is provided with the appliance, make sure that it adheres properly to the bottom part of the appliance frame. **The seal must be fitted properly around the entire perimeter of the appliance and especially along the corners in order to create a seal between the work top and the appliance itself so as to prevent spills or splashes from leaking into the cabinet below.**

The appliance must be fitted into the worktop using the fixing clamps - see diagram.

Very important

It is essential to install the appliance on a totally flat surface. Any damage caused due to incorrect fitting may alter the characteristics or impair performance. Insert the appliance into the hole, pressing firmly around the frame to make it adhere to the worktop.

Electrical Connection

Electrical Connection

THIS APPLIANCE MUST BE EARTHED.

The installation procedure must be carried out by a qualified electrician.

The electrical safety of this appliance is guaranteed only if the appliance is correctly earthed in compliance with the standards of electrical safety.

The manufacturer can under no circumstances be considered responsible for any damage that might occur due to incorrect earthing of this appliance.

Connecting the supply cord to the electrical mains:

The appliance must be connected to a double pole mains switch which must be installed between the appliance and the mains. The double pole mains switch must have a minimum of 3mm of space between the contacts, be sized to the load and comply with current regulations (the switch must not be able to disconnect the earth conductor).

The supply cord should conform to BS6004 conductor size 4mm² and must be positioned so that no part of it reaches a temperature of 50°C higher than room temperature.

Before making the connection, make sure that:

- the limiter switch (fuse) and the residual wiring can support the appliance load (see the rating plate).
- the mains system is properly earthed in compliance with current regulations and provisions.
- there is easy access to the socket or the double pole mains switch after the appliance is installed.
- the isolation switch must not be positioned directly above the appliance.

Power supply 230V
Power 2300W



After Sales Service

"No company is better positioned to offer an after sales service on a Hotpoint appliance than us - the manufacturer"

As part of our commitment to you, all Hotpoint appliances have the added benefit of a fully inclusive parts and labour guarantee for the first 12 months. In addition to this you also have the advantage of **free replacement parts for the first 5 years** when fitted by a Hotpoint engineer. When the 12 months parts and labour guarantee expires we offer the following after sales service options:

Repair Service and Information Help Desk

UK: 08709 066066

www.theservicecentre.co.uk

Republic of Ireland: 1850 302 200

Note: Our operators will require the Model number and the Serial number of your appliance

Available 364 days a year with a fast, effective and value for money service. We have the largest white goods repair service in the UK with over 1200 of our own fully trained engineers. All repairs include a parts and labour guarantee for 12 months from the date of the repair.

If you require any information or have any questions about your appliance, our operators are on hand with help and advice.

All this ensures that you will receive the best available after sales service possible.

Extended Warranties

UK: 08709 088 088

www.theservicecentre.co.uk

Republic of Ireland: 1850 502 200

Whether you have just one or a number of Hotpoint appliances in your kitchen, we offer two service cover plans to give you total peace of mind.

- Repair Protection Plan - FREE service repairs for a single Hotpoint appliance during the period of cover.
- Kitchen Cover - FREE service repairs for all your Hotpoint appliances less than 8 years old.

Genuine Parts and Accessories UK: 08709 077 077

www.theservicecentre.co.uk

Republic of Ireland: (01) 842 6836

A wide range of genuine parts and accessories are available from our hotline or through our web site.

Genuine parts and accessories, extended warranties and service repairs are all available on our web-site at:



www.theservicecentre.co.uk



Guarantee

"Satisfaction guaranteed or your money back"

We give you a unique 'satisfaction guaranteed' promise - **valid for 90 days** - after you have purchased your Hotpoint appliance. If there is a technical problem simply call Hotpoint Repair service or visit our web-site at www.theservicecentre.co.uk and where necessary, we will arrange for an engineer to call. If the technical problem is not resolved under this guarantee, **we will replace your machine or, if you prefer, give you your money back.**

All Hotpoint appliances carry a fully inclusive 12 month parts and labour guarantee as well as free replacement parts for the first 5 years (except microwaves, selected integrated appliances and cooker hoods, which have a one year guarantee) provided that they are fitted by a Hotpoint engineer.

Guarantee terms and conditions

Your guarantee is only applicable in the United Kingdom or Republic of Ireland and is subject to the following provisions that your appliance:

- Has been installed and used correctly in accordance with this instruction booklet.
- Has been used solely for domestic purposes and is located on domestic premises (ie. not for commercial or trade use).
- Has been properly connected to a suitable electrical supply voltage as stated on the appliance rating plate.
- Has not been subject to misuse, accident, modified or repaired by anyone other than one of our own service engineers.



For pre purchase information on any other Hotpoint product call: 08701 50 60 70
or visit: www.hotpoint.co.uk

Recycling & Disposal Information

As part of Hotpoint's continued commitment to helping the environment, Hotpoint reserves the right to use quality recycled components to keep down customer costs and minimise material wastage.

Please dispose of packaging and old appliances carefully.

To minimise risk of injury to children, remove the plug and cut mains cable off flush with the appliance. Dispose of these parts separately to ensure that the appliance can no longer be plugged into a mains socket.



Key Contacts

After Sales Service

Over 1200 trained specialists, directly employed by us, ensure that you can have complete confidence in both the appliances and services we offer.



Repair Service and Information Desk

UK: 08709 066 066

(Open 8 to 8 Mon - Fri, 8 to 6 Sat, 10 to 4 Sun & Bank Holidays)

www.theservicecentre.co.uk

Republic of Ireland: 1850 302 200

Note: Our operators will require the following information:

Model number:

Serial number:

Extended Warranties

UK: 08709 088 088

(Open 8 to 8 Mon - Sun)

www.theservicecentre.co.uk

Republic of Ireland: 1850 502 200

Genuine Parts and Accessories

UK: 08709 077 077

(Open 8-30 to 5-30 Mon - Fri & 9 to 12 Sat)

www.theservicecentre.co.uk

Republic of Ireland: (01) 842 6836