

Hurricane

Owner's Manual



The Ultimate In Style & Performance[®]

Pride
Mobility Products, Ltd.

Alber Technologies Limited,
Chantry Court, Sovereign Way,
Chester, England. CH1 4QN
Tel: 01244 394240 Fax: 01244 394254
Email: Info@alber.co.uk www.alber.co.uk

SAFETY GUIDELINES

Read and follow all of the instructions in this manual before you attempt to operate your Scooter for the first time.

The following symbols will be used throughout this Owner's Manual to identify warnings and cautions. It is very important for you to read and understand them completely.



WARNING! Failure to heed the warnings in this owner's manual may result in personal injury.



CAUTION! Failure to heed the cautions in this owner's manual may result in damage to your Scooter.

Please be sure to fill out and return your warranty card. Also, notify us of any change of address so that we can keep you apprised of important information about safety, new products, and new options that can increase your ability to use and enjoy your Scooter.

Your Hurricane:

Body Colour _____

Serial # _____

Purchase Date _____

Options _____

Your authorized Pride Mobility Products Ltd., provider:

Name _____

Address _____

Phone _____

CONTENTS

I. INTRODUCTION	5
II. SAFETY	6
Safety Precautions	6
Doors	7
Elevators	7
Ramps and Other Inclines	7
Driving Surfaces	8
III. SPECIFICATIONS	9
IV. DESCRIPTION	11
V. BATTERIES AND CHARGING	17
Reading your Battery Voltage	17
Charging your Batteries	17
Frequently Asked Questions (FAQs)	18
VI. OPERATION	22
Pre-ride Adjustments and Checks	22
Getting on Your Scooter	22
Operating Your Scooter	22
Getting Off Of Your Scooter	23
Auto Shutoff Feature	23
VII. COMFORT ADJUSTMENTS	24
Tiller Angle Adjustment	24
Seat Height Adjustment	24
Power Seat Actuator	24
Sliding Seat Adjustment	25
Seat Rotation	25
Armrest Width Adjustment	25
Armrest Height Adjustment	26
High-back Seat Headrest Adjustment	26
VIII. ASSEMBLY AND DISASSEMBLY	27
Assembly	27
Disassembly	29
IX. TROUBLESHOOTING	30
X. CARE AND MAINTENANCE	31
XI. WARRANTY	32

COPYRIGHT

Pride Mobility Products, Ltd. cannot be held responsible for any damage or injury incurred due to improper or unsafe use of a scooter. Nor can Pride be held responsible for any damage or injury incurred during or resulting from attempts to follow the instructions and recommendations set forth in this owner's manual or in any of the instructions displayed on or accompanying the product itself. If you do not feel capable of safely following any of the instructions and recommendations pertaining to your scooter, please contact your authorized Pride provider.

I. INTRODUCTION

Welcome to Pride Mobility Products, Ltd. (Pride). Congratulations on the purchase of your new Scooter. The Hurricane design combines the most advanced state-of-the-art components with modern, attractive styling. We are certain that the design features and trouble-free operation of your new Scooter will add convenience to your daily living.

At Pride, your safety is important to us. **Please read and follow all of the instructions in this manual before you attempt to operate your Scooter for the first time.** These instructions were produced for your benefit. Your understanding of these instructions is essential for the safe operation of your new Scooter.

This owner's manual is compiled from the latest specifications and product information available at the time of publication. We reserve the right to make changes, as they become necessary. Any changes to our products may cause slight variations between the illustrations and explanations in this manual and the product you purchased.

As an owner of a Pride product, you are invited to register your product's warranty and enroll in the Pride Owners Club. You may do so by filling out and returning your enclosed registration card or by visiting Pride's web site at www.pridemobility.com. As a registered member, each time you visit our site, you will have access to the most interactive and honest educational venue available today for people with mobility needs, their families and friends.

From the cover page of our site, click on the button that reads "Owners Club" to enter a page dedicated to current and potential Pride Mobility Product Owners. You will gain access to interviews, stories, recreation ideas, daily living tips, product and funding information, and interactive message boards. On these message boards you are invited to speak with other Pride customers as well as Pride representatives who are available to assist you with any questions or concerns you may have. You will receive a free gift simply for registering with the Pride Owners Club.

We want to hear your questions, comments, and suggestions about this manual. We would also like to hear about the safety and reliability of your new Scooter, as well as about the service you received from your Pride provider. Also, notify us of any change of address, so we can keep you apprised of important information about safety, new products, and new options that can increase your ability to use and enjoy your Scooter. Please feel free to write us at the address below:

Alber Technologies Limited,
Chantry Court, Sovereign Way,
Chester, England. CH1 4QN
Tel: 01244 394240 Fax: 01244 394254
Email: Info@alber.co.uk www.alber.co.uk

If you experience any problems with your Scooter that you are not able to solve, or if you do not feel confident in your ability to perform any of the instructions contained in this manual, please contact your local Pride provider. Once you understand how to operate and take care of your Scooter, we are certain that it will give you years of trouble-free service and enjoyment.

The Pride Team

II. SAFETY

It is imperative that you read this entire manual and understand all of the safety precautions before you attempt to operate your new Hurricane for the first time.

SAFETY PRECAUTIONS

- Make certain that the seat is locked into place and the key is removed from the key switch before getting on or off of your Scooter.
- Make sure that you set the 4 - 8 mph switch to 4 and the speed adjustment dial to the tortoise (slowest speed) setting when you begin using your Hurricane.
- Ensure the seat is in a locked position when you are operating your Scooter.
- Do not operate your Scooter while you are under the influence of alcohol.
- Check with your physician if you are taking any medication(s) that may affect your ability to operate your Scooter.
- Do not exceed the specifications in this manual.
- Do not carry passengers on your Hurricane, under any circumstances.
- Never drive your Scooter across the side of an incline or diagonally up or down an incline; do not stop, if possible, while driving up or down an incline.
- Keep both hands on the tiller and your feet on the floorboard at all times while operating your Scooter. This recommended driving position gives you the most control over your Scooter.
- Use extreme caution when driving on busy streets, in parking lots, or in shopping malls.
- Proceed with extreme caution when driving near raised surfaces or unprotected ledges or drop-offs (kerbs, porches, stairs, etc.).
- Drive slowly through turns.
- Make certain that the tyres are properly inflated (30 psi).
- Never use your Scooter as a seat in a moving vehicle. Your Scooter is not designed to be used as such and cannot protect you in the event of an automobile accident or an abrupt stop.
- Secure the batteries before loading your Hurricane into another vehicle for transport.
- Disconnect the batteries if you are not going to operate your Scooter for more than 48 hours.

WARNING! Do not expose the electronics to any type of moisture at any time (rain, snow, mist, or wash). Such exposure can damage the electronics. Never attempt to ride a Hurricane that has been exposed to moisture until it has dried thoroughly.

Do not operate or store your Hurricane where it may be exposed to inclement weather conditions such as rain, snow, mist, and below-freezing temperatures (such as storage on an outside car/van lift). Attempting to operate your Scooter in such conditions can damage the electronics and potentially result in loss of control.



Do not operate your Hurricane in icy or slippery conditions or on salted surfaces (i.e., walks or roads). Such use may result in an accident, personal injury, or adversely affect the performance and/or safety of your Scooter.

Always protect batteries from freezing temperatures and never charge a frozen battery. This damages the battery and may cause personal injury. Attempting to charge a battery in freezing conditions does not prevent a battery from freezing.

Contact your authorized Pride provider if you have any questions after reading this manual.

II. SAFETY

As you begin to use your Hurricane during your daily activities, you will encounter situations that may require some practice. Simply take your time as you operate your Scooter and you will soon be in full and confident control as you maneuver through doorways, on and off of elevators, up and down ramps, and over moderate terrain.

DOORS

- Determine if the door opens toward or away from you.
- Use your hand to turn the knob or push the handle or push-bar.
- Drive your Hurricane slowly forward to push the door open; or drive your Scooter slowly backwards as you pull the door open.

ELEVATORS

Modern elevators have a door-edge safety mechanism that, when pushed, reopens the elevator door(s).

- If you are in the doorway of an elevator when the door(s) begin to close, push on the rubber door edge or allow the rubber door edge to contact your Scooter to reopen the door.
- Use care that pocketbooks, packages, or Hurricane accessories do not become caught in the elevator doors.

RAMPS AND OTHER INCLINES

More and more buildings have ramps with specified degrees of inclination, designed for easy and safe scooter access. Some ramps may have turning switchbacks that require you to have good cornering skills on your Hurricane.

- Take slow, wide swings with your Scooter's front wheel(s) around any tight corners. If you do that, the rear wheels will follow a wide arc and will not cut the corner short, bump into, or get hung up on any railing corners.
- When driving down a ramp, keep your Hurricane's speed adjustment dial (see IV. "Description") set to the tortoise (slowest speed setting) to ensure a safely controlled descent.
- Avoid sudden stops and starts.

Other inclines may be natural or, if man-made, not designed specifically for scooters. Figure 1 illustrates your Hurricane's stability and its ability to climb grades under various weight loads and under controlled testing conditions.

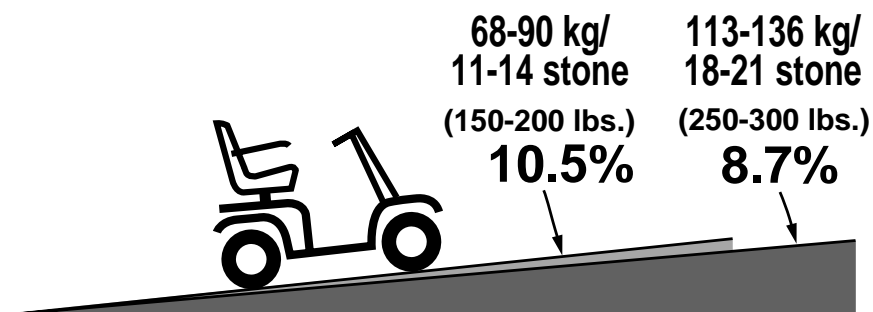

Figure 1. Maximum Recommended Incline Angle

II. SAFETY

The controlled tests show that, when you approach an incline, it is best to lean forward. See figures 2 and 3. This shifts the center of gravity of you and your Hurricane toward the front of the Scooter for improved stability.



WARNING! Do not exceed the incline guidelines or any other specifications presented in this manual.



Figure 2. Normal Driving Position

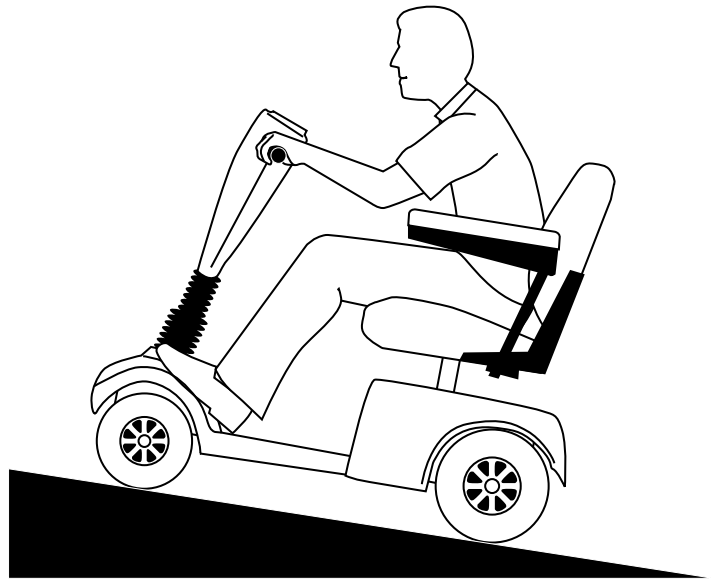

Figure 3. Increased Stability Driving Position

DRIVING SURFACES

Your Hurricane was designed to provide optimum stability under normal driving conditions — dry, level surfaces composed of concrete or asphalt. However, Pride recognizes that there will be times when you will operate your Hurricane on surfaces other than concrete or asphalt. For that reason, we also designed your Hurricane to perform admirably on packed soil, grass, and gravel.

- Feel free to use your Hurricane safely on lawns and in park areas.
- Avoid tall grass that can entangle the running gear.
- Packed soil, gravel, driveways, or roads will not present a problem for your Hurricane.
- Avoid loosely packed gravel and sand.
- If you feel unsure about a driving surface, avoid that surface.

III. SPECIFICATIONS

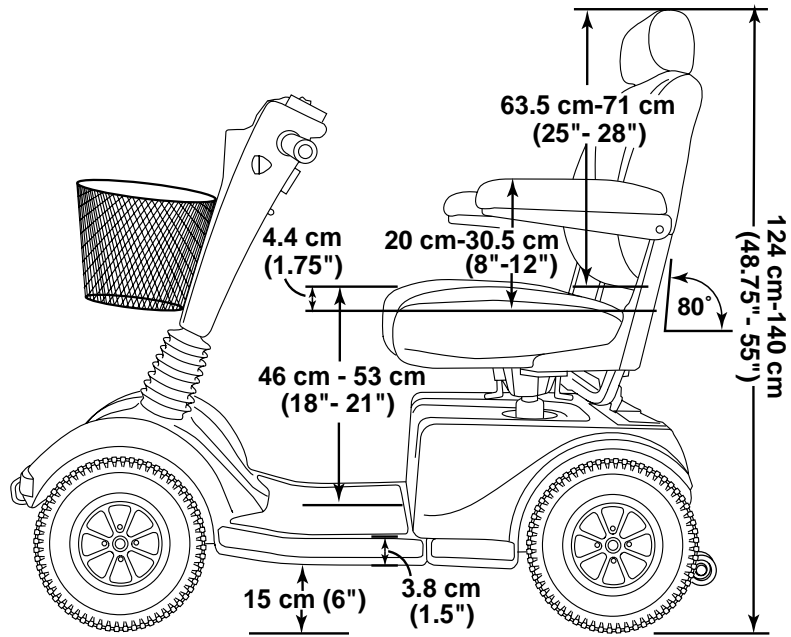
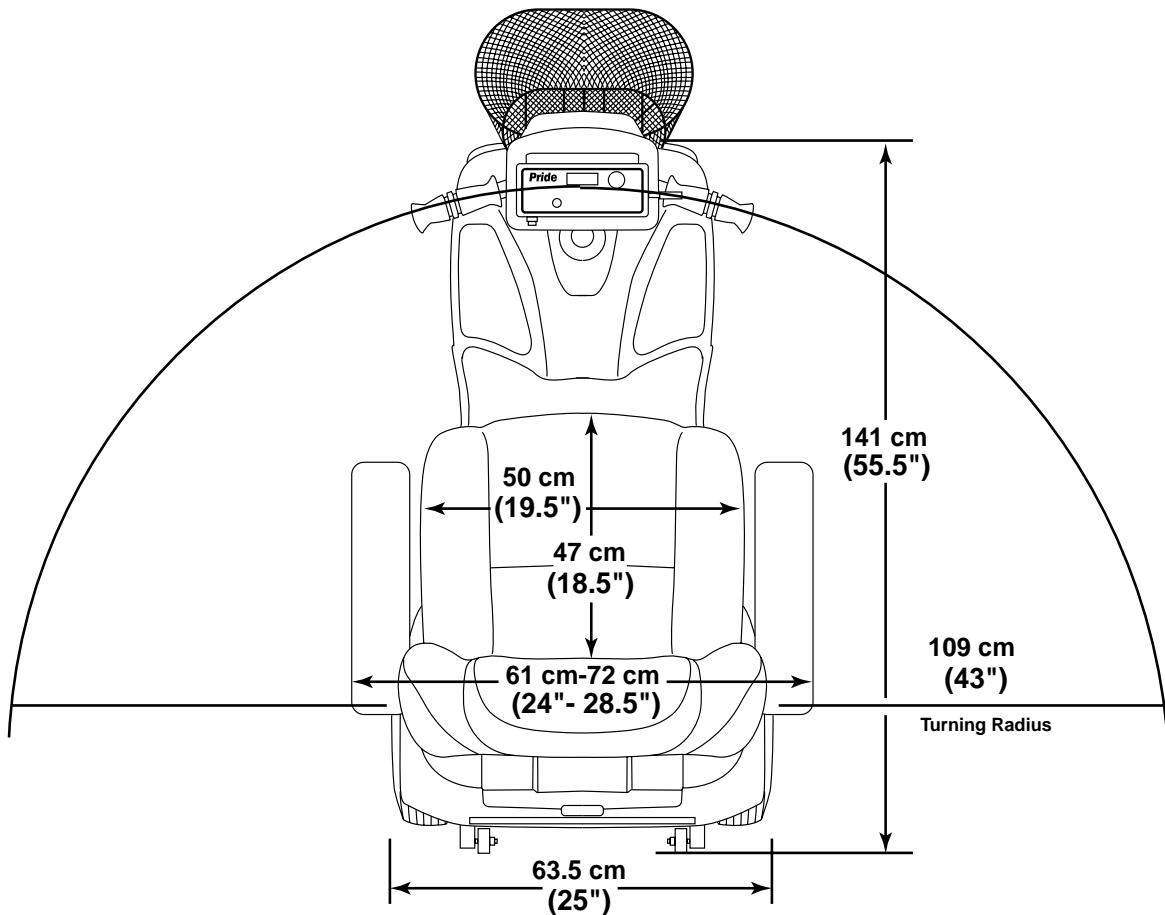

Figure 4. Hurricane Specifications



Specifications	
Length:	141 cm (55.5")
Width:	63.5 cm (25")
Tyres:	Type: Pneumatic Front: 10 cm x 29 cm (4" x 11.5") Rear: 10 cm x 30 cm (4" x 12")
Weight Capacity:	136 kg/21 stone (300 lbs.) maximum
Battery Type (not included):	Choices: Two 12V, 32 amp hours (AH), U-1 type SLA (sealed lead-acid) or gell cell
Horsepower:	2.0 HP (Peak)
Charger:	Onboard 5-amp charger
Speed (Max):	Variable up to 13 km/hr (8 mph) (60% reverse)
Maximum Grade:	Please refer to figure 1.
Range:	Up to 32 - 40 km (20 - 25 miles) per charge with 32 AH batteries Up to 40 - 48 km (25 - 30 miles) per charge with 40 AH batteries
Turning Radius:	109 cm (43")
Body Colours:	Candy Apple Red, Forest Green, Viper Blue, or Onyx Black
Seating:	Style: High back with headrest and sliders Dimensions: 49.5 cm (19.5") width (usable) x 63.5 cm - 71 cm (25" - 28") height (usable) x 47 cm (18.5") depth (usable) Seat cover material: Gray, brown, or beige vinyl Armrests: Match seat cover material User adjustable seat height from ground: 65 cm - 72 cm (25.5" - 28.5") User adjustable seat height from scooter deck: 46 cm - 53 cm (18" - 21")
Included Features:	Sliding seat, energy-saving auto shutoff feature, height adjustable armrests, front and rear suspension, full lighting package, front and rear bumpers, front basket, rearview mirror, hand brake, height adjustable armrests
Brakes:	Electronic regenerative braking and electromechanical disc brake
Rear Wheel Drive:	Sealed transaxle, 24 VDC motor
Wheels:	Pride MicroMag aluminum alloy wheels in black, red, or gold
Tiller Type:	Infinitely adjustable between forward stop and scooter deck
Freewheel Mechanism:	Freewheel release lever located on transaxle
Scooter Weight:	Total weight with batteries: w/two 12V, 32 AH batteries: 99 kg (219.5 lbs.) w/two 12V, 40 AH batteries: 106 kg (234.5 lbs.) Total weight without batteries: 76 kg (169.5 lbs.) Component Breakdown: Front Section: 25 kg (61.5 lbs.) Rear Section (without batteries or rear shroud): 31 kg (68.5 lbs.) Rear Plastic Shroud: 1.5 kg (3.5 lbs.) Seat: 16 kg (36 lbs.) Batteries (2 required): 11 kg (25 lbs.) each (12V, 32 AH) 15 kg (32.5 lbs.) each (12V, 40 AH)
Front-to-rear Lockup:	Lock pin and cam lever system
Ground Clearance:	15 cm (6")
Optional Accessories:	Cup holder, rear basket, dust cover, flag, oxygen holder, canopy, power elevating seat, crutch holder

IV. DESCRIPTION

Your Hurricane is an indoor/outdoor motorized electric scooter designed to enhance your personal mobility. It was designed to travel primarily on smooth surfaces such as sidewalks, roads, parking lots, floors, and driveways. For easy transportation or storage, you can disassemble your Hurricane into seven components. See figure 5. To decrease the rear section weight or to charge your batteries while your Scooter is disassembled, you can also remove the utility tray and its subcomponents from the rear section. For further information on disassembly, see VIII. “Assembly and Disassembly.” For further information on charging your batteries while your Hurricane is disassembled, see V. “Batteries and Charging.”

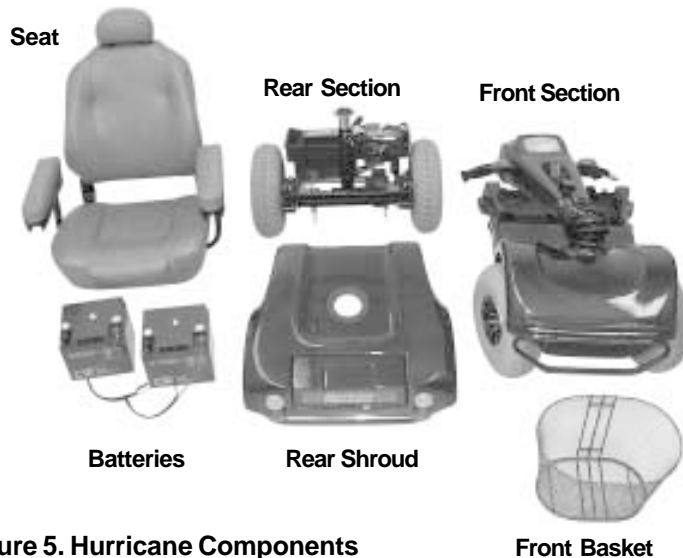

Figure 5. Hurricane Components

CONTROL CONSOLE ASSEMBLY

The control console assembly located on the front section houses all of the controls you need to operate your Hurricane. See figure 6.



WARNING! Do not expose the control console assembly to moisture. In the event it does become exposed to moisture, do not attempt to operate your Hurricane until it has thoroughly dried.

Tiller Adjustment Lever

This lever allows you to adjust the tiller between the forward stop and the scooter deck. For tiller adjustment instructions, see VII. “Comfort Adjustments.”

Hazard Light Switch

This switch enables you to control your Hurricane’s front and rear (amber) hazard lights.

- Toggle this switch to turn the hazard lights on and off.

Throttle Control Levers

These levers allow you to control your Hurricane’s forward and reverse speed up to the maximum speed you preset on the speed adjustment dial. For instructions on how to operate your Hurricane’s throttle control, see VI. “Operation.”

IV. DESCRIPTION

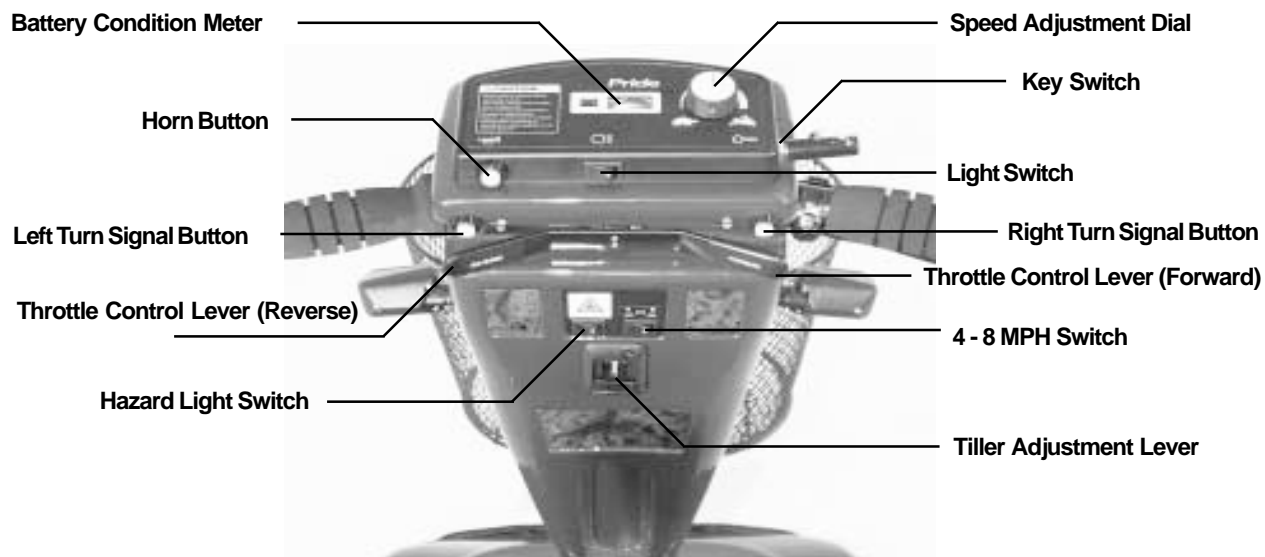

Figure 6. Control Console Assembly

Left and Right Turn Signal Buttons

Use these buttons to turn on the left and right turn signal (amber) lights.

- Push the appropriate turn signal button once to turn on the signal light before turning your scooter. Your Hurricane's turn signals are timed to shut off automatically.

Horn Button

This button activates a warning horn.

- Ensure the key is fully inserted into the key switch and press the horn button to sound the horn.

Battery Condition Meter

When your Hurricane's key is fully inserted, this meter indicates the approximate battery voltage strength. For further information on battery charging, see V. "Batteries and Charging."

Speed Adjustment Dial

This dial allows you to select and limit your Hurricane's speed up to the highest speed you set with the 4 - 8 mph switch (6.4 - 12.8 km/hr).

- Set the speed between the slowest (image of the tortoise) and the fastest (image of the hare) speed settings.

Key Switch

This switch enables you to power up and power down your Hurricane.

- Fully insert the key into the key switch to power up your Hurricane.
- Pull the key out to power down your Hurricane.



WARNING! If you remove the key from the key switch while your Hurricane is in motion, the electronic brakes engage and your Scooter comes to an abrupt stop!

IV. DESCRIPTION

Light Switch

This switch enables you to control your Hurricane's headlight and running (rear red) lights.

- Toggle this switch to turn your headlight and running lights on and off.

4 - 8 MPH Switch

This switch limits the top speed of your Hurricane to either 4 or 8 mph (6.4 or 12.8 km/hr).

- Toggle this switch to either 4 or 8.

NOTE: When driving indoors, set the switch to 4 mph (6,4 km/hr).

Power Seat Switch (Optional)

If your Hurricane is equipped with a power seat, this switch enables you to raise and lower the seat. For power seat adjustment directions, see VII. "Comfort Adjustments."



WARNING! Strict adherence to the following safety rules is vital:

- Do not attempt to raise or lower the seat while your Hurricane is in motion!
- Adjust the power seat only when your Hurricane is level and stationary!
- Drive your Scooter only with the seat in the lowest position!
- Do not operate your Hurricane with the power seat elevated!

Handbrake Lever

Your Hurricane is equipped with a handbrake lever, located on the tiller handle. See figure 7. This lever provides you with additional stopping power.

- Release the throttle and gently squeeze the handbrake lever to come to a stop.



CAUTION! If you do not release the throttle before using the handbrake, your Hurricane may not come to a complete stop.



Figure 7. Handbrake Lever

IV. DESCRIPTION

REAR SECTION

The onboard battery charger, charger cord, batteries, electronic controller module, main circuit breaker, freewheel lever, and the motor/transaxle assembly are located on the rear section of your Hurricane. See figure 8. (The batteries and motor/transaxle assembly are not shown in figure 8.) Refer to VIII. “Assembly and Disassembly” for instructions on removing the rear shroud.

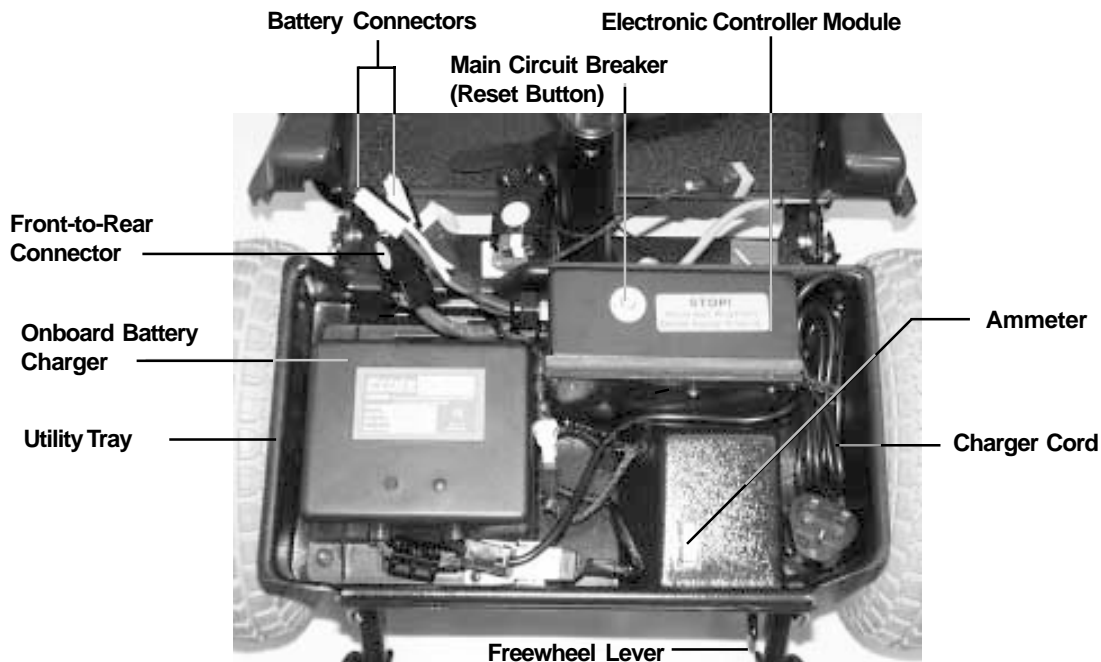

Figure 8. Utility Tray Components

Onboard Battery Charger

The onboard battery charger converts household current (AC) to direct current (DC) and charges your Hurricane’s batteries. See V. “Batteries and Charging.”

- The charger is located on the utility tray.
- The charger is a black box with a green LED indicator on the exterior of the case.
- The charger cord extends from the charger. Keep the cord coiled when not in use.



WARNING! For your safety, use only the supplied onboard battery charger.

Batteries

The batteries store the electrical energy that powers your Hurricane. For directions on charging your batteries, see V. “Batteries and Charging.”

Electronic Controller Module

This module is located behind the batteries and at the forward right corner of your Hurricane’s rear section. The electronic controller module receives electrical signals from the console controls and sends power to the motor, the brakes, and the lighting system.

IV. DESCRIPTION



WARNING! Do not expose the electronic controller module to moisture. If it does become exposed to moisture, do not attempt to operate your Hurricane until it has thoroughly dried.

Main Circuit Breaker

When the voltage in your Hurricane's batteries becomes low or your Scooter is heavily strained because of excessive loads, the main circuit breaker may trip to protect your Scooter's motor and electronics from damage.

- The main circuit breaker reset button is mounted on the electronic controller module cover.
- The main circuit breaker reset button pops out when the breaker trips.
- When the breaker trips, the entire electrical system of your Hurricane is shut down.
- Allow a minute or so for your Hurricane's electronics to "rest."
- Push in the reset button to reset the breaker.
- If the breaker trips frequently, you may need to charge your batteries more often or have your Pride provider perform a 50-amp load test on your Hurricane's batteries.
- If the main circuit breaker trips repeatedly, see your authorized Pride provider for service.

Anti-Tip Wheels (Not shown in photo)

The anti-tip wheels are an integral and important safety feature of your Hurricane which prevent your Scooter from tipping backwards on an incline. They are located at the rearmost part of your Hurricane. Do not, under any circumstances, remove the anti-tip wheels from your Scooter.

Manual Freewheel Lever

Whenever you want to push your Hurricane for short distances, you can put it in manual freewheel mode.

WARNING! It is important to remember that when your Hurricane is in freewheel mode, the braking system is disengaged.



Follow these safety rules when using the freewheel mode:

- **Do not disengage the drive motors when your Hurricane is on an incline; your Scooter could roll down on its own and cause injury!**
- **Before placing your Hurricane in or taking it out of freewheel mode, ensure the key is removed from the key switch.**
- **Never sit on a Scooter when it is in freewheel mode.**
- **When you have finished pushing your Scooter, always return it to the drive mode to lock the brakes.**

- The manual freewheel lever is located on the end of the motor/transaxle assembly at the right rear of the Hurricane.
- Pull up on the manual freewheel lever to disable the drive system and the brake system; you will then be able to push your Hurricane.
- Push down on the manual freewheel lever to reengage the drive system and the brake system and take your Hurricane out of freewheel mode.

Motor/Transaxle Assembly

The motor/transaxle assembly is the geared transmission and differential. It is a one piece, direct drive, fully sealed assembly which provides quiet operation with maximum power.

IV. DESCRIPTION

OPTIONAL ACCESSORIES

For information concerning these and other optional accessories, see your authorized Pride provider.



Cup Holder



Flag



Rear Basket



Oxygen Holder

V. BATTERIES AND CHARGING

Your Hurricane requires two long-lasting, 12-volt, deep-cycle batteries that are sealed and maintenance free. Recharge the batteries with the convenient 5-amp onboard battery charger. See figure 8.

Two important points to remember are:

- Charge your Hurricane's batteries with the supplied onboard battery charger prior to using it for the first time.
- Keep your batteries fully charged to keep your Hurricane running smoothly.

NOTE: Use only the onboard battery charger supplied with your Hurricane.

READING YOUR BATTERY VOLTAGE

The battery condition meter on the control console assembly indicates the approximate strength of your batteries. (The meter reads 26 volts when your batteries are fully charged.) To check the charge, you must first unplug the battery charger and insert the key into the key switch.

You can also use the ammeter to check your batteries' charge. The ammeter is located on the utility tray under the rear shroud. (The amperage reading should be at or near zero (0) when the batteries are fully charged.) The battery charger must be plugged into a wall outlet to obtain an ammeter reading.

CHARGING YOUR BATTERIES

You can charge your batteries with your Hurricane completely assembled or with your Hurricane disassembled, as described in VIII. "Assembly and Disassembly." We strongly recommend you charge your batteries while your Hurricane is fully assembled. However, if you are traveling and you disassemble your Hurricane to transport it, you may find it necessary to charge your batteries. In such instances, it is easier to take out the utility tray and batteries to perform the charging.

Follow these steps to safely charge your batteries while your Hurricane is fully assembled.

1. Position your Scooter close to a standard wall outlet.
2. Remove the key from the key switch.
3. Ensure the freewheel lever is in the down (drive) position.
4. Extend the charger power cord and plug it into the wall outlet. We recommend you charge your batteries for 8 to 14 hours.
5. When the batteries are fully charged, unplug the charger power cord from the wall outlet, recoil the cord, and place it neatly inside the utility tray.

NOTE: There is a charger inhibit on your Hurricane. Your Scooter does not run and the battery condition meter does not operate while the batteries are charging.

Follow these steps to safely charge your batteries with the utility tray and batteries removed.

1. Disassemble your Hurricane, as described in VIII. "Assembly and Disassembly."
2. Position your utility tray and batteries close to a standard wall outlet.
3. Plug both the 2-pin battery harnesses into the adjoining harnesses extending from the electronic controller module on the utility tray. See figure 9.
4. Extend the charger power cord and plug it into the wall outlet. We recommend you charge your batteries for 8 to 14 hours.

V. BATTERIES AND CHARGING

5. When the batteries are fully charged, unplug the charger power cord from the wall outlet, recoil the cord, and place it neatly inside the utility tray.
6. Unplug both battery harnesses.
7. Reassemble your Scooter as described in VIII. “Assembly and Disassembly.”

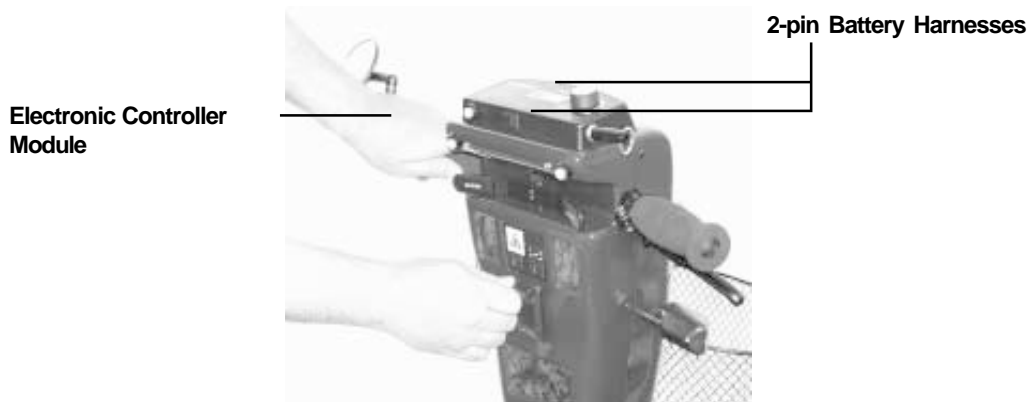

Figure 9. Utility Tray and Batteries

FREQUENTLY ASKED QUESTIONS (FAQs)

How does the charger work?

When your Hurricane's battery voltage is low, the charger works harder and sends more electrical current to the batteries to bring up their charge. As the voltage of the batteries approaches a full charge, the charger sends less electrical current to the batteries. When the batteries are fully charged, the current sent to them from the charger is at nearly zero amperage. Therefore, when the charger is plugged in, it maintains the charge on the batteries but does not overcharge them. Even though the charging maintenance feature is built into your Hurricane's onboard charger, we do not recommend that you charge your Hurricane's batteries for more than 24 consecutive hours.

What does the LED on the charger indicate?

The red LED indicates that the batteries are being charged. The green LED turns on after the batteries have been fully charged. In some instances, the green LED may stay on after the charger has been unplugged from the wall outlet. Although users may perceive this as a charger malfunction, it is normal. The green LED goes off after a few minutes, when the batteries reach 26 VDC.

Can I use a different charger?

For the safest, most efficient, and balanced charging of your Hurricane's batteries, you should simultaneously charge both batteries using only the manufacturer supplied onboard battery charger.

How often must I charge the batteries?

Two major factors must be considered when deciding how often to charge your Hurricane's batteries: all day Scooter use on a daily basis and infrequent Scooter use.

V. BATTERIES AND CHARGING

With these considerations in mind, you can determine just how often and for how long you should charge your Hurricane’s batteries. We designed the onboard charger so that it does not overcharge your PMV’s batteries; however, you may encounter some problems if you do not charge your batteries often enough and if you do not charge them on a regular basis. Following the five guidelines below provides safe and reliable battery operation and charging.

1. If you use your scooter daily, charge its batteries as soon as you finish using it for the day. Your scooter will be ready each morning to give you a “full day” of service. We recommend you charge your Hurricane’s batteries for 8 to 14 hours after daily use.
2. If you use your scooter once a week or less, charge its batteries at least once a week for 12 to 14 hours at a time.
3. Keep your Hurricane’s batteries fully charged.
4. Avoid deeply discharging your Hurricane’s batteries.
5. Do not charge your Hurricane’s batteries for more than 24 consecutive hours.

How can I get maximum range or distance per charge?

Rarely will you have ideal driving conditions—smooth, flat, hard driving surfaces with no wind or curves. You will often face hills, sidewalk cracks, uneven and loosely packed surfaces, curves, and wind. All of these driving conditions affect the distance or running time per battery charge. The following are a few suggestions for obtaining the maximum range per battery charge.

- Always fully charge your Hurricane’s batteries prior to your daily use.
- Maintain 30 psi (pounds per square inch) in all of your Hurricane’s tyres.
- Plan your route ahead to avoid as many hills, cracked, broken, or soft surfaces as possible.
- Limit your baggage weight to essential items.
- Try to maintain an even speed while your scooter is in motion.
- Avoid stop-and-go driving.

What type and size of battery should I use?

We recommend deep-cycle batteries that are sealed and maintenance free. Both sealed lead-acid (SLA) and gel cell are deep-cycle batteries that are similar in performance in your Hurricane. Do not use wet-cell batteries, which have removable caps.

NOTE: Do not remove the caps from sealed batteries. Water cannot be added to sealed batteries. Cap removal voids the battery warranty and may cause damage to the batteries and to your Hurricane.

Use these specifications to reorder deep-cycle batteries:

Battery Specifications	
Type:	Deep-cycle (SLA or gel cell)
Size:	U-1 (32 AH only)
Voltage:	12V each
Amperage:	32 AH or 40 AH

V. BATTERIES AND CHARGING

To change a battery in your Hurricane:

1. Remove the seat and the rear shroud. See VIII. “Assembly and Disassembly.”
2. Disconnect the battery tie-down strap.
3. Disconnect the battery cables from the electronic controller module.
4. Disconnect the battery cables from the battery terminals.
5. Remove the old battery.
6. Place a new battery in the battery well.
7. Connect the red battery cable to the positive (+) battery terminal.
8. Connect the black battery cable to the negative (-) battery terminal.
9. Reconnect the battery cables to the electronic controller module.
10. Reconnect the battery tie-down strap.
11. Reinstall the rear shroud and the seat.



WARNING! Battery posts, terminals and related accessories contain lead and lead compounds. Wash hands after handling.

Why do my new batteries seem weak?

Deep-cycle batteries employ a different chemical technology than that used in car batteries, nickel-cadmium batteries (nicads), or in other common battery types. Deep-cycle batteries are specifically designed to provide power, drain down their charge, and then accept a relatively quick recharge.

We work closely with our battery manufacturer to provide batteries that best suit your Hurricane’s specific electrical demands. Fresh batteries arrive daily at Pride and are shipped fully charged to our customers. During shipping, the batteries may encounter temperature extremes that may influence their initial performance. Heat diminishes the charge on the battery; cold slows the available power and extends the time needed to recharge the battery.

It may take a few days for the temperature of your Hurricane’s batteries to stabilize and adjust to their new room or ambient temperature.

More importantly, it takes a few charging cycles (a partial drain followed by a full recharge) to establish the critical chemical balance that is essential to a deep-cycle battery’s peak performance and long life.

Please follow these steps to properly break in your Hurricane’s new batteries for maximum efficiency and service life.

1. Fully recharge any new battery prior to its initial use. This initial charging cycle brings the batteries up to about 88% of their peak performance level.
2. Operate your new Hurricane in familiar and safe areas. Drive slowly at first, and do not travel too far from your home or familiar surroundings until you have become accustomed to your Hurricane’s controls and have properly broken in the batteries.
3. Fully recharge the batteries. This recharge should bring the batteries up to about 90% of their peak performance level.
4. Operate your Hurricane again.
5. Fully recharge the batteries again.
6. After four or five charging cycles, the batteries are able to receive a charge of 100% of their peak performance level and are able to last for an extended period of time.

V. BATTERIES AND CHARGING

How can I ensure maximum battery life?

Fully charged deep-cycle batteries provide reliable performance and extended battery service life. Keep your Hurricane's batteries fully charged whenever possible. Batteries that are deeply discharged, infrequently charged, or stored without a full charge may be permanently damaged and cause unreliable performance and limited service life.

How should I store my Hurricane and its batteries?

If you plan on not using your Hurricane for an extended period of time, it is best to:

- Fully charge the batteries prior to storage.
- Disconnect the battery harnesses from the electronic controller module.
- Store your Hurricane in a warm, dry environment.
- Avoid storing your Hurricane where it will be exposed to temperature extremes.



WARNING! If your Hurricane's batteries do become frozen, do not attempt to charge them. Cold or frozen batteries should be allowed to warm up for several days prior to recharging.

For prolonged storage, you may wish to place several boards under the frame of your Hurricane to raise the Scooter off the ground and take the weight off the tyres. This reduces the possibility of flat spots developing on the areas of the tyres contacting the ground.

VI. OPERATION

Familiarize yourself with the following checklist before you get on your Hurricane. Some of the checks must be performed prior to getting on your Scooter.

PRE-RIDE ADJUSTMENTS AND CHECKS

- Have you fully charged the batteries? See V. “Batteries and Charging.”
- Is the manual freewheel lever in the drive (down) mode? See IV. “Description.” Never leave the freewheel lever pulled up unless you are manually pushing your Scooter.
- Is your proposed path clear of people, pets, and obstacles?
- Have you planned your route to avoid adverse terrain and as many inclines as possible?
- Are you positioned comfortably in the seat? See “Getting On Your Scooter,” below.
- Is the seat at the proper height? See VII. “Comfort Adjustments.”
- Is the seat locked securely in place? See VII. “Comfort Adjustments.”
- Is the tiller handle at a comfortable setting and locked securely in place? See VII. “Comfort Adjustments.”
- Is the key fully inserted into the key switch? See IV. “Description.”
- Is the speed adjustment dial set to a slow setting? See IV. “Description.”
- Are you grasping the handgrips with a thumb resting on each side of the throttle control lever? See IV. “Description.”
- Does your Scooter’s horn work properly?

GETTING ON YOUR SCOOTER

- Make certain that the key is removed from the key switch.
- Stand at the side of your Scooter.
- Pull up on the seat rotation lever to unlock the seat and rotate the seat until it faces you; release the seat rotation lever to lock the seat securely in place.
- Position yourself comfortably and securely in the seat.
- Pull up on the seat rotation lever and rotate the seat until you face forward; release the seat rotation lever to lock the seat securely in place.
- Make certain that your feet are safely on the floorboard.

OPERATING YOUR SCOOTER

After planning your route:

- Set the 4 - 8 switch to your desired maximum speed of 4 or 8 mph (6.4 km/hr or 12.8 km/hr); then set the speed adjustment dial to your desired speed. We recommend you initially set the 4 - 8 switch to 4 and the speed adjustment dial to the tortoise.
- Insert the key into the key switch.
- With your hands on the handgrips, use your thumb to gently push the right throttle lever to disengage the brakes and move forward; the electric brake automatically disengages and your Scooter accelerates smoothly to the speed you set with the speed adjustment dial.
- Pull on the left handgrip to steer your Scooter to the left.
- Pull on the right handgrip to steer your Scooter to the right.
- Move the tiller to the center position to drive straight ahead.
- Gently release the throttle control lever to decelerate and come to a complete stop. The electric brake automatically engages when your Hurricane comes to a stop.

NOTE: To fully stop your Hurricane, release the throttle, then gently squeeze the handbrake.

V I . O P E R A T I O N

- To move in reverse, use your thumb to gently push the left throttle lever to disengage your Hurricane's brakes and move rearward.

NOTE: Your Hurricane's reverse speed is 40% slower than the speed you set with the speed adjustment dial and the 4 - 8 mph switch.

GETTING OFF OF YOUR SCOOTER

- Bring your Scooter to a complete stop.
- Make certain that the key is removed from the key switch.
- Pull up on the seat rotation lever to unlock the seat and rotate the seat until you are facing toward the side of your Scooter; release the seat rotation lever to lock the seat securely in place.
- Carefully get out of the seat and stand to the side of your Scooter.
- You may, if you wish, leave the seat facing to the side to facilitate boarding your Scooter the next time you are going to operate it.

AUTO SHUTOFF FEATURE

Your Hurricane is equipped with an energy-saving auto shutoff feature that is designed to preserve your Scooter's battery life. If you mistakenly leave the key in your Hurricane but do not use your Scooter for approximately 20 minutes, your Scooter automatically shuts down.

If your Hurricane auto shutoff feature takes effect, perform the following steps to resume normal operation.

- Remove the key from the key switch.
- Reinsert the key into the key switch.

VII. COMFORT ADJUSTMENTS

TILLER ANGLE ADJUSTMENT

You can adjust the tiller infinitely between the forward stop and the scooter deck.



WARNING! Remove the key before adjusting the tiller. Never attempt to adjust the tiller while your Scooter is in motion.

1. Pull up on the tiller adjustment lever. See figure 10.
2. Move the tiller to a comfortable position.
3. Release the tiller adjustment lever. The tiller will remain in that position.

NOTE: In order to lower the tiller to the scooter deck, you must first remove the seat and both batteries. See VIII. "Assembly and Disassembly."



Figure 10. Tiller Adjustment Lever

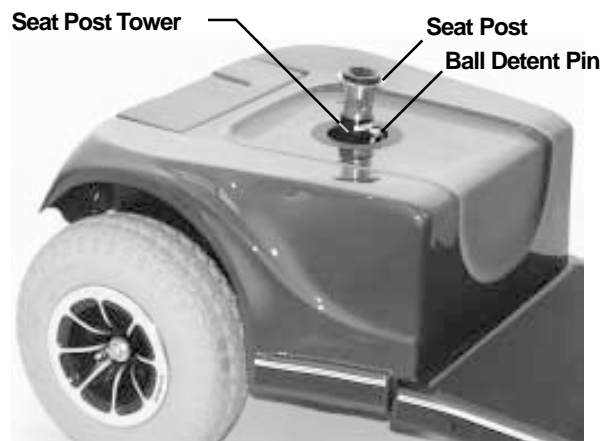

Figure 11. Seat Height Adjustment

SEAT HEIGHT ADJUSTMENT

The seat can be repositioned to one of three different heights.

1. Remove the seat from your Hurricane. See VIII. "Assembly and Disassembly."
2. Use the attached ring to pull and remove the ball detent pin from the seat post tower. See figure 11.
3. Raise or lower the seat post to the desired seat height.
4. Holding the seat post at that height, match up the holes in the seat post and in the seat post tower.
5. Fully insert the ball detent pin.
6. Replace the seat.

POWER SEAT ACTUATOR (OPTIONAL)

Your Hurricane may be equipped with a power seat actuator. The actuator raises and lowers the seat automatically.

WARNING! The power seat actuator is intended for operation only while your Scooter is stationary and on a level surface. Its purpose is to aid you in reaching objects.



Strict adherence to the following safety rules is vital to your safety:

- Do not attempt to raise or lower the seat while in motion!
- Do not operate your Scooter with the power seat elevated!

We recommend you drive the vehicle only with the seat in the lowest position.

VII. COMFORT ADJUSTMENTS

Operating Your Power Seat

1. Ensure your Hurricane is level and stationary.
2. Toggle on the power seat switch.
3. To raise the power seat, place your hands on the handgrips and use your thumb to push the right side of the lever.
4. Release the lever when you have attained your desired height.
5. To lower the power seat, place your hands on the handgrips and use your thumb to push the left side of the lever.
6. Release the lever when you have attained your desired height.
7. Ensure your seat is in the lowest position and toggle off the power seat switch before you attempt to drive your Hurricane again.

SLIDING SEAT ADJUSTMENT

You can move the sliding seat forward or rearward to suit your needs.

1. Pull up on the front-to-back seat release lever. See figure 12.
2. Slide the seat into a comfortable position.
3. Release the front-to-back seat release lever to lock the seat securely in place.

SEAT ROTATION

The seat lock lever locks the seat in one of four positions.

1. Pull up on the seat lock lever to unlock the seat. See figure 12.
2. Rotate the seat to the desired position.
3. Release the seat lock lever to lock the seat securely in place.

ARMREST WIDTH ADJUSTMENT

The armrest width of your Hurricane can be adjusted inward or outward.

1. Turn the armrest adjustment knobs at the back of the seat frame counterclockwise to loosen. See figure 12.
2. Slide the armrests in or out to the desired width.
3. Turn the armrest adjustment knobs clockwise to tighten.

NOTE: You can also lift up the armrests to allow getting on and off of your Hurricane easier.

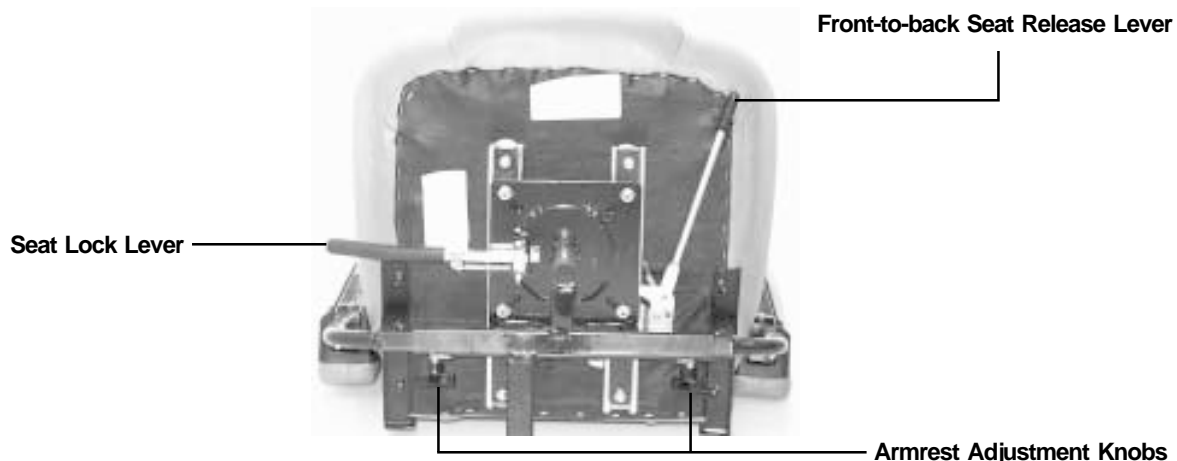

Figure 12. Seat Adjustments

VII. COMFORT ADJUSTMENTS

ARMREST HEIGHT ADJUSTMENT

You will need the following tools to adjust the height of the armrests:

- 5/32" hex key
- 1/8" hex key
- 7/16" wrench

1. Loosen the setscrew on the side of the height adjustment tube with the 1/8" hex key. See figure 13.
2. Loosen and remove the acorn nut and screw holding the height adjustment tube in place.
3. Raise or lower the height adjustment tube to the desired height.
4. Align the holes in the adjustment tube with the holes in the armrest upright.
5. Insert the screw through the holes in both the height adjustment tube and the armrest upright.
6. Install and tighten the acorn nut.
7. Tighten the setscrew on the side of the height adjustment tube.
8. Repeat for the other armrest.

HIGH-BACK SEAT HEADREST ADJUSTMENT

If your Hurricane is equipped with a high-back seat, it has an adjustable headrest that locks into three heights.

1. Press the lock release button to unlock the headrest. See figure 14.
2. Slide the headrest up or down until it locks into the desired position.

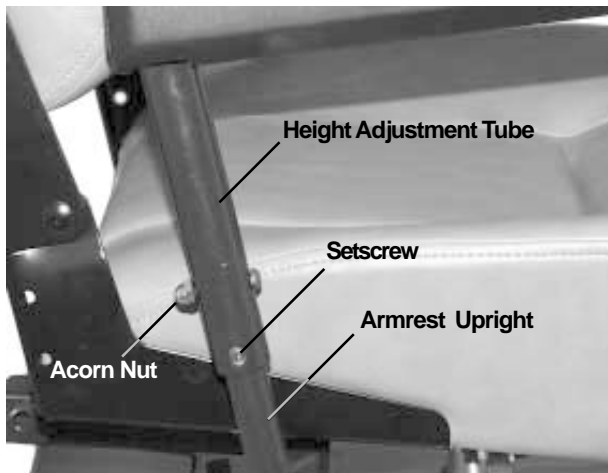

Figure 13. Armrest Height Adjustment



Figure 14. High-Back Seat Headrest Adjustment

VIII. ASSEMBLY AND DISASSEMBLY

No tools are required to assemble or disassemble your Hurricane. Always assemble or disassemble your Hurricane on a level, dry surface with sufficient room for you to work and move around your Scooter. Keep in mind that the disassembled sections of the Hurricane take up more floor space than the assembled Scooter.

ASSEMBLY

1. Place the freewheel lever in drive (down) position.
2. Position the front and rear sections next to each other. See figure 15.
3. Tilt the rear end to a horizontal position and insert the longer tube of the front end into the rear section first; make sure that the locking cam levers are vertically positioned and the locking pins are removed.
4. Slide the two sections of the unit together until the front half reaches its insertion limit.
5. Secure the front and rear sections with ball detent pins. See figure 16.
6. Ensure the tiller is in an upright position.
7. Push the locking cam levers back to their locked (down) position. See figure 17.
8. Clip the front basket onto the front of the tiller.
9. If you removed the utility tray from the rear component, replace the tray by aligning the reusable fasteners on the utility tray with those on the Scooter's rear component; gently press down on the utility tray to ensure it is secure.
10. Plug the large white 9-pin plastic connector from the front section of the Hurricane into the mating plug found on the control module on the utility tray. The two orange dots present on both plugs should be adjacent to each other and enable quick plug mating. See figure 18.

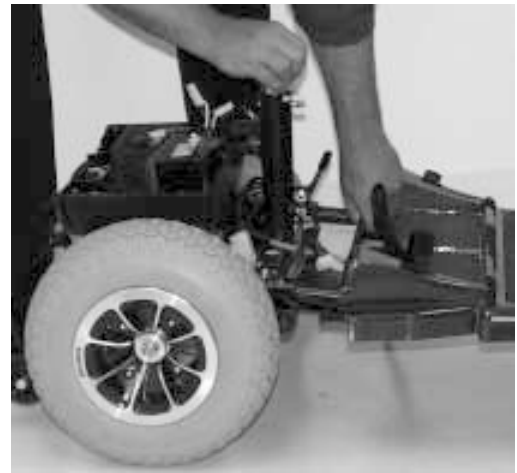

Figure 15. Position the Front and Rear Sections



Figure 16. Secure Sections with Ball Detent Pins



Figure 17. Push the Locking Cam Levers



Figure 18. Plug in the 9-pin Connector

VIII. ASSEMBLY AND DISASSEMBLY

11. Put the batteries in place and plug the 2-pin battery harnesses into the adjoining harnesses that are also located on the control module. See figures 19 and 20.
12. Connect the battery tie-down strap.
13. If you removed the utility tray from the rear component, connect the 6-pin motor harness plug. See figure 21.
14. Gently place the rear shroud over the seat pedestal.
15. Connect the rear light harness. See figure 22. Make sure that the rear plastic shroud does not make any contact with the rear wheels.
16. Slide the shroud down in place.
17. Carefully lift the seat and slide the small seat post (on the seat bottom) into the seat post tower. See figure 23.
18. Rotate the seat until it locks into place.



Figure 19. Put Batteries in Place



Figure 20. Connect Battery Harnesses



Figure 21. Connect Motor Harness Plug



Figure 22. Connect Rear Light Harness



Figure 23. Slide the Seat into Place

VIII. ASSEMBLY AND DISASSEMBLY

DISASSEMBLY

You can disassemble your Hurricane into seven or eight pieces: the seat, the front frame, the front basket, the rear frame, the rear shroud, and the two batteries; you can also remove the utility tray from the rear frame, if necessary. Place the Hurricane in an area where you have sufficient clearance to move the parts around. You need about 1.5 meters in all directions. You may need assistance to lift some of the Hurricane components. See III. “Specifications” for individual component weights.

1. Place the freewheel lever in the drive (down) position.
2. Pull up on the seat rotation lever to unlock the seat; then rotate the seat an eighth of a turn and lift the seat up and off of the Hurricane.
3. Gently lift the rear shroud off of the Hurricane. You will not be able to completely remove the rear shroud because of the rear light harness connection.
4. Unplug the rear light harness.
5. Unplug the large white 9-pin front-to-rear connector that attaches the front control console harness to the utility tray.
6. Unplug both battery harnesses and lift both batteries off of the Hurricane.



CAUTION! Failure to unplug both battery harnesses and the control console harness prior to disassembly could result in permanent damage to your Hurricane.

7. If you plan to remove the utility tray, disconnect the 6-pin motor harness plug. If you do not plan to remove the utility tray, go to step 10.

NOTE: You can decrease the weight of the rear component by removing the utility tray.

8. Lift up and remove the utility tray (optional).
9. Pull up on and remove the front basket.
10. Grab the handle grip on the tiller, pull upward on the release lever, and gently lower the tiller down to the center of the Hurricane chassis until it is fully lowered.
11. Remove the ball detent pins and lift the locking cam levers.
12. Separate the front section from the rear section.

IX. TROUBLESHOOTING

Any electromechanical device occasionally requires some troubleshooting. However, most of the problems that may arise can usually be solved with a bit of thought and common sense. Many of these problems occur because the batteries are not fully charged or because the batteries are worn down and can no longer hold a charge.

PROBLEM	POSSIBLE SOLUTIONS
All of my Scooter systems appear to be “dead.”	<p>One of the following actions may eliminate the problem.</p> <ul style="list-style-type: none"> ■ Ensure the key is fully inserted in the key switch. ■ Ensure the batteries are fully charged. ■ Push in the main circuit breaker reset button. ■ Ensure both battery harnesses are firmly connected to the electronic controller module and to the battery terminals. ■ Ensure the 9-pin connector is firmly attached.
My Scooter’s battery condition meter shows a full charge, but my Scooter does not move when I push the throttle.	<p>Ensure your Scooter was not left in freewheel mode. (Push down on the manual freewheel lever to restore normal operation.)</p> <p><i>NOTE: When the manual freewheel lever is pulled up, your Scooter’s brakes are disengaged and all power to the transaxle is cut.</i></p>
My Scooter’s main circuit breaker repeatedly trips.	<p>One of the following actions may eliminate the problem.</p> <ul style="list-style-type: none"> ■ Charge your Scooter’s batteries more frequently. ■ Have both of your Scooter’s batteries load tested by your authorized Pride provider. ■ Obtain a battery load tester at most any automotive parts store; follow the directions supplied with the load tester.
My Scooter’s battery condition meter dips way down and the motor surges or hesitates when I press the throttle control lever.	<p>One of the following actions may eliminate the problem.</p> <ul style="list-style-type: none"> ■ Fully charge your Scooter’s batteries. ■ Have your authorized Pride provider load test each battery. ■ Obtain a battery load tester at most any automotive parts store; follow the directions supplied with the load tester.

If you experience any problems with your Hurricane that you are not able to solve, immediately contact your authorized Pride provider for information, maintenance, and service.

X. CARE AND MAINTENANCE

The following areas require periodic inspection and/or care and maintenance.

TYRE PRESSURE:

- We recommend you maintain the tyre pressure at 30 psi for optimum scooter performance; overinflating a tyre can cause it to explode.

TYRE CONDITION AND TREAD WEAR:

- Regularly inspect your Hurricane's tyres for signs of wear.
- Use a rubber conditioner on your Hurricane's tyres to preserve them.
- Do not put rubber conditioner on tread area of tyres; the tyres may become dangerously slippery.

EXTERIOR SURFACES:

- Bumpers and trim benefit from an occasional application of rubber or vinyl conditioner.
- Do not use rubber or vinyl conditioner on your Hurricane's vinyl seat; it may become dangerously slippery.

BATTERY TERMINAL CONNECTIONS:

- Ensure the terminal connections remain tight and uncorroded.
- Ensure the batteries sit flat in the battery wells.
- Ensure the battery terminals face the rear of your Hurricane.

WIRING HARNESSSES:

- Regularly check all wiring connections.
- Regularly check all wiring insulation, including the charger power cord, for wear or damage.
- Repair or replace any damaged connector, connection, or insulation before you use your Hurricane.

SEAT POST:

- Periodically clean dirt and grime from the detached seat post with any lubricant solution; wipe away excess buildup with a soft cloth.

ABS PLASTIC SHROUDS:

- Apply a light coat of car wax to the shrouds to help retain their high gloss; the shrouds are formed from durable ABS plastic and coated with an advanced formula urethane paint.

AXLE BEARINGS AND THE MOTOR/TRANSAXLE HURRICANE ASSEMBLY:

- You do not need to lubricate these items, as they are all prelubricated and sealed.

CONSOLE, CHARGER, AND ELECTRONIC CONTROLLER MODULE:

- Keep these areas away from moisture.
- Let any of these areas dry thoroughly before operating your Hurricane if they have been exposed to moisture.

STORAGE:

- Refer to "How should I store my Hurricane and its batteries?" in V. "Batteries and Charging."

XI. WARRANTY

TWO-YEAR LIMITED WARRANTY

Structural frame components, including: platform, fork, seat post, and frame welds.
Drive train, including: transaxle, motor, and brake.

ONE-YEAR LIMITED WARRANTY

Your Pride Scooter is fully guaranteed for twelve (12) months from the date of purchase against faults arising due to defects in manufacture or materials. This warranty does not detract from, but is in addition to your legal rights.

All electronic parts, including controllers and battery chargers, have a one (1) year warranty. Servicing to the controller or battery charger must be carried out by your local Pride Mobility Products, Ltd., provider. Any attempt to open or dismantle these items renders the guarantee void on that item.

NOT COVERED UNDER WARRANTY

This guarantee does not extend to those items which may need replacement due to normal wear and tear (tyres, belts, bulbs, upholstery, plastic shrouds, motor brushes, fuses, and batteries), or damage to the product caused by misuse or accident for which Pride Mobility Products, Ltd., or its agent cannot be held responsible. This warranty does not include labor or service calls.

BATTERIES

Batteries are covered by a twelve (12) month warranty from the original manufacturer.

Gradual deterioration in performance due to being left in a discharged state, left in cold conditions for long periods of time, or worn out through heavy use is not covered.

SERVICE CHECKS AND WARRANTY SERVICE

Warranty service can be performed by an authorized Pride provider. Please contact your local Pride provider for advice on the current cost affecting the service visit.