

BASIC OPERATION INSTRUCTIONS

GC2TM Controller

ACN# 088 609 661

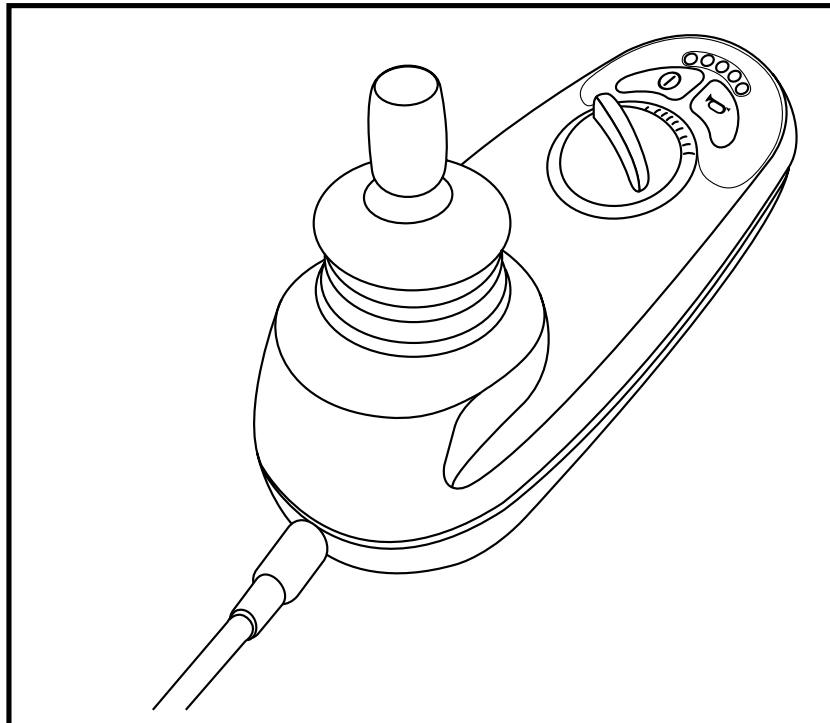

Pride
Mobility Products Corp.

SAFETY GUIDELINES



WARNING! An authorized Pride Provider or a qualified technician must perform the initial setup of this product and must perform all of the instructions in this manual.

The symbols below are used throughout this owner's manual and on the controller to identify warnings and important information. It is very important for you to read them and understand them completely.



WARNING! Indicates a potentially hazardous condition/situation. Failure to follow designated procedures can cause either personal injury, component damage, or malfunction. On the product, this icon is represented as a black symbol on a yellow triangle with a black border.



MANDATORY! These actions should be performed as specified. Failure to perform mandatory actions can cause personal injury and/or equipment damage. On the product, this icon is represented as a white symbol on a blue dot with a white border.



PROHIBITED! These actions are prohibited. These actions should not be performed at any time or in any circumstances. Performing a prohibited action can cause personal injury and/or equipment damage. On the product, this icon is represented as a black symbol with a red circle and a red slash.

NOTE: These instructions are compiled from the latest specifications and product information available at the time of publication. We reserve the right to make changes as they become necessary. Any changes to our products may cause slight variations between the illustrations and explanations in this manual and the product you have purchased. The latest/current version of this manual is available on our website.

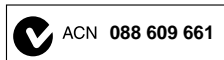

Copyright © 2008
Pride Mobility Products Corporation
INFMANU3785/Rev A/September 2008

TABLE OF CONTENTS

INTRODUCTION	5
GC2 CONTROLLER	7
PRECAUTIONARY GUIDELINES	7
OPERATING THE GC2 CONTROLLER	11
CONTROLLER COMMUNICATION CONNECTOR	13
LOCK MODE	14
THERMAL ROLLBACK	14
FAULT CODES	15
CARE AND MAINTENANCE	16
WARRANTY	16

LABEL INFORMATION

PRODUCT SAFETY SYMBOLS

The symbols below are used on the controller to identify warnings, mandatory actions, and prohibited actions. It is very important for you to read and understand them completely.



Read and follow the information in the owner's manual.



Avoid exposure to rain, snow, ice, salt, or standing water whenever possible. Maintain and store in a clean and dry condition.



EMI-RFI - This product has been tested and passed at an immunity level of 20 V/m.



Disposal and recycling - Contact your authorized Pride Provider for information on proper disposal and recycling of your Pride product and its packaging.



Use correct tie-down points for controller harness to prevent the harness from getting caught in the drive tires, pinched in the seat frame, or damaged when passing through doorways.

INTRODUCTION

WELCOME to Pride Mobility Products Corporation (Pride). The product you have purchased combines state-of-the-art components with **safety**, comfort, and styling in mind. We are confident that the design features will provide you with the conveniences you expect during your daily activities. Understanding how to **safely** operate and care for this product should bring you years of trouble free operations and service.

Read and follow all instructions, warnings, and notes in this manual and all other accompanying literature before attempting to operate this product for the first time. In addition, your **safety** depends upon you, as well as your provider, caretaker, or healthcare professional in using good judgement.

This manual is to be used in addition to the power base owner's manual that came with your power chair. If there is any information in this manual which you do not understand, or if you require additional assistance for setup or operation, please contact your authorized Pride Provider. **Failure to follow the instructions, warnings, and notes in this manual and those located on your Pride product can result in personal injury and/or product damage and will void Pride's product warranty.**

PURCHASER'S AGREEMENT

By accepting delivery of this product, you promise that you will not change, alter, or modify this product or remove or render inoperable or unsafe any guards, shields, or other safety features of this product; fail, refuse, or neglect to install any retrofit kits from time to time provided by Pride to enhance or preserve the safe use of this product.

INFORMATION EXCHANGE

We want to hear your questions, comments, and suggestions about this manual. We would also like to hear about the safety and reliability of your new Pride product, and about the service you received from your authorized Pride Provider. Please notify us of any change of address, so we can keep you apprised of important information about safety, new products, and new options that can increase your ability to use and enjoy your Pride product.

NOTE: If you ever lose or misplace your product registration card or your copy of this manual, contact us and we will be glad to send you a new one immediately.

My authorized Pride Provider Is:

Name: _____

Address: _____

Phone Number: _____

Purchase Date: _____

GC2 CONTROLLER

The GC2 controller is a fully-programmable, modular electronic controller system that allows you to operate your power chair. It is designed to allow the user to have complete control over chair movement and speed.

The controller has been pre-programmed to meet a typical user's needs. The program is set using either a personal computer with software provided by the controller manufacturer or with a hand-held programmer, also provided by the controller manufacturer.



WARNING! The controller program can affect speed, acceleration, deceleration, dynamic stability, and braking. If it is programmed incorrectly or outside of the safe limits as determined by your healthcare professional, it can create a dangerous situation. Only the power chair manufacturer, an authorized representative of the manufacturer, or a trained service technician should program the controller.

PRECAUTIONARY GUIDELINES

Before operating the GC2 controller, please read the following. These guidelines are provided for your benefit and will aid you in the safe operation of the control system.

- Turn off the power to the controller when transferring to or from your power chair.
- Follow all of the procedures and heed the warnings as explained in your power chair owner's manual.

Electromagnetic and Radio Frequency Interference (EMI/RFI)



WARNING! Laboratory tests have shown that electromagnetic and radio frequency waves can have an adverse affect on the performance of electrically-powered mobility vehicles.

Electromagnetic and Radio Frequency Interference can come from sources such as cellular phones, mobile two-way radios (such as walkie-talkies), radio stations, TV stations, amateur radio (HAM) transmitters, wireless computer links, microwave signals, paging transmitters, and medium-range mobile transceivers used by emergency vehicles. In some cases, these waves can cause unintended movement or damage to the control system. Every electrically-powered mobility vehicle has an immunity (or resistance) to EMI. The higher the immunity level, the greater the protection against EMI. This product has been tested and has passed at an immunity level of 20 V/m.



WARNING! Be aware that cell phones, two-way radios, laptops, and other types of radio transmitters may cause unintended movement of your electrically-powered mobility vehicle due to EMI. Exercise caution when using any of these items while operating your mobility vehicle and avoid coming into close proximity of radio and TV stations.



WARNING! The addition of accessories or components to the electrically-powered mobility vehicle can increase the susceptibility of the vehicle to EMI. Do not modify your power chair in any way not authorized by Pride.

WARNING! The electrically-powered mobility vehicle itself can disturb the performance of other electrical devices located nearby, such as alarm systems.

NOTE: For further information on EMI/RFI, go to the Resource Center on www.pridemobility.com. If unintended motion or brake release occurs, turn your power chair off as soon as it is safe to do so. Call Pride or your authorized Pride Provider to report the incident.

GC2 Controller Features

Figure 1 provides information on the GC2 components and connections. Use this diagram to familiarize yourself with the function and location of each component before using the GC2 controller.

The following functions are available with the GC2 controller:

- Joystick Control

The joystick is used to control the direction and speed of the power chair.

- Speed Adjustment

The user can increase or decrease the maximum speed of the power chair.

- Thermal Rollback

A safety feature designed to prevent the power chair from overheating and causing damage to the motors or controller.

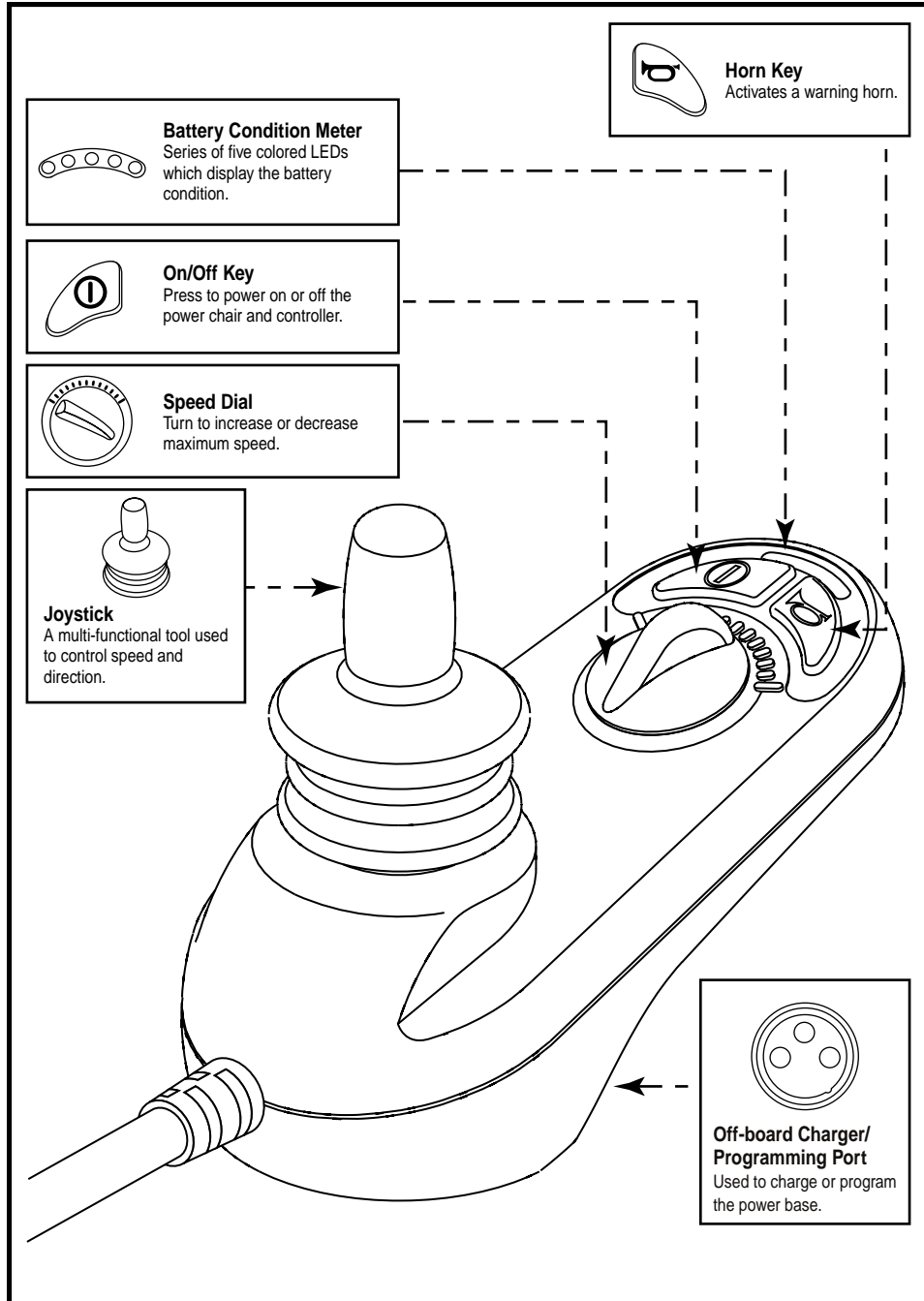

Figure 1. GC2 Components and Connections

OPERATING THE GC2 CONTROLLER

The GC2 controller is used to operate your power chair and all of its components.

The GC2 controller system consists of (see figure 2):

1. Joystick
2. Control panel
3. Joystick module
4. Off-board charging/programming socket
5. Power module
6. Controller communication connector

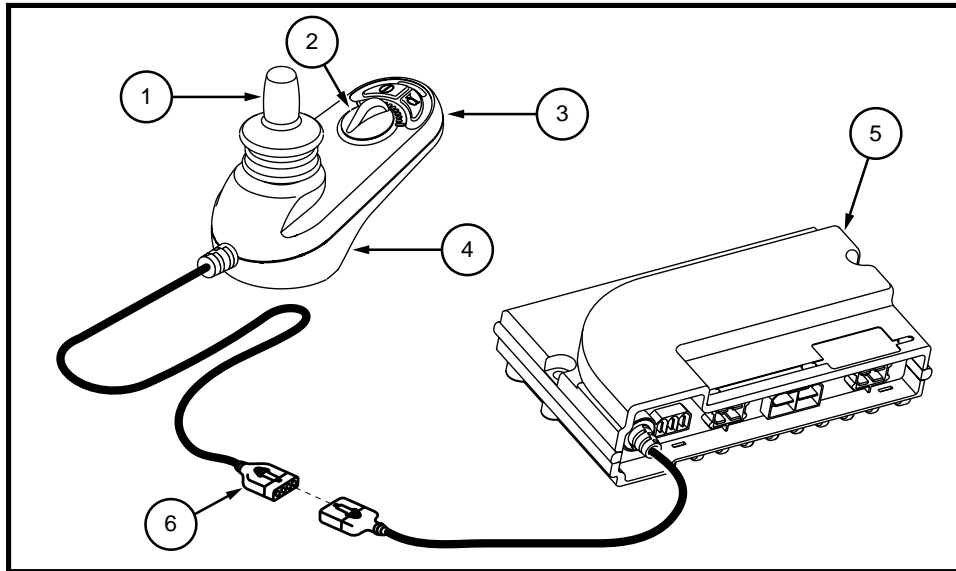

Figure 2. GC2 Controller

Joystick Control

The joystick controls the driving speed and direction of the power chair. When the joystick is at rest, it is in the neutral (center) position, and the chair is stationary. In order to drive the chair, the joystick must be taken out of neutral. Moving the joystick in any direction will switch the chair from neutral to drive, and the chair will move in the direction indicated by joystick position. The farther away from the neutral position the joystick is, the faster the chair will move in that direction. To stop chair movement, simply release the joystick or move it back to the neutral position. The chair's electromagnetic brakes will engage after the chair has come to a controlled stop.

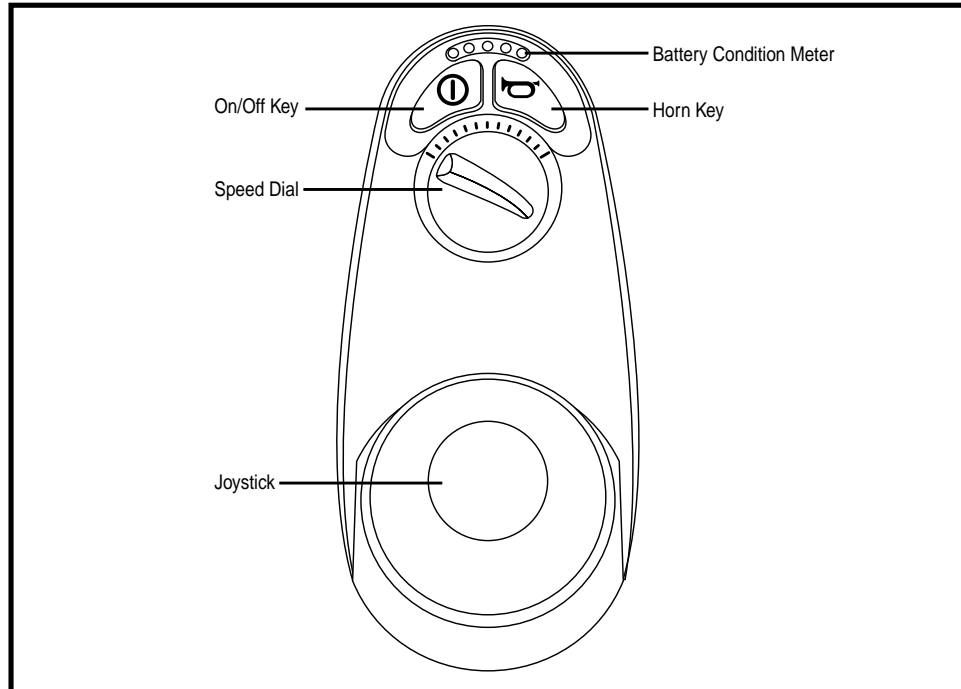

Figure 3. Controller Keypad

Control Panel

The control panel is located directly in front of the joystick. It contains keys and a dial that you will use to control your power chair. See figure 2.

On/Off Key

The on/off key turns the system on and off.



WARNING! Unless faced with an emergency situation, do not use the on/off key to stop the chair. This will cause the power chair to stop abruptly.

WARNING! Always turn the power off when you are stationary to prevent unexpected movement.

Horn Key

The horn key activates a warning horn.

Speed Dial

The GC2 controller provides a speed dial to control the speed of the power chair. See figure 3.

To change the speed:

1. Push the on/off key to power on the chair and the controller.
2. To increase your speed, turn the speed dial clockwise.
3. To decrease your speed, turn the speed dial counterclockwise.

***NOTE:** We recommend that the first few times you operate your power chair, you set the speed to the slowest setting until you become familiar with your new power chair.*

Battery Condition Meter

The battery condition meter consists of five LEDs arranged in an arc over the on/off and horn keys. See figure 1. When functioning as the battery condition meter, this indicates the status of the electrical system using LED codes. For example, as the battery voltage drops, the number of LEDs reduces from right to left. When the battery capacity drops to 10% or below, the left red LED will flash.

Battery condition meter codes are as follows:

- **Left Red LED Flashing Slowly or Steady:** Battery charge is low; Charge the batteries as soon as possible.
- **Red and Yellow LEDs Flashing:** Battery charge is low; Charge the batteries overnight.
- **Step up of LEDs:** The controller is in programming, inhibit, or charging mode.
- **All LEDs Flashing Quickly:** The joystick was not in the center position when the power was switched on, or the controller system detected a fault; Refer to the Fault Code Table.

CONTROLLER COMMUNICATION CONNECTOR

The controller communications connector provides the GC2 with a connection to the power module.



MANDATORY! Prevent controller harness damage! Avoid routing the controller harness on the outside of the armrest pad. Route the harness under the armrest or toward the inside of the armrest pad. Use correct tie-down points for the controller harness to prevent the harness from getting caught in the drive tires, pinched in the seat frame, or damaged when passing through doorways.

LOCK MODE

The controller is equipped with a feature that enables you to “lockout” unauthorized users.

To lock the controller:

1. While the power is on, press and hold the on/off key until it beeps (approximately 1 second).
2. Release the on/off key.
3. Move the joystick to the full forward position until it beeps.
4. Move the joystick to the full rearward position until it beeps.
5. Release the joystick. There will be one long beep. The controller system is now locked.

NOTE: The battery condition meter will be rippling from side to side. The sequence will continue until the power is turned off or until the controller is unlocked.

To unlock the controller:

1. Press the on/off key to turn on the controller. The battery condition meter will ripple the “locked” sequence.
2. Move the joystick to the full forward position until it beeps.
3. Move the joystick to the full rearward position until it beeps.
4. Release the joystick. There will be one long beep. The controller system is now unlocked.

THERMAL ROLLBACK

The GC2 controller is equipped with a thermal rollback circuit which monitors the temperature of the chair’s motors and controller. If either exceeds the safe operating temperature, the controller reduces the output to 50% of full operation level. This reduces the chair’s speed and allows a cool down period. Once the temperature returns to a safe level, the chair will resume normal operation.

FAULT CODES

The battery condition meter will flash fault codes when the controller system detects an abnormal condition in the electrical system. All of the battery condition meter LEDs will flash a number of times quickly, then pause, then flash again. The battery condition meter will continue to flash the fault codes until the problem is fixed. The table below identifies the individual fault codes. If any of these fault codes persist, contact your authorized Pride Provider.

Fault Code	Probable Cause(s)	Possible Solution
1 Flash	The batteries need charging. There is a bad connection to the batteries.	Check the battery connections. If the battery connections are good, then try charging the batteries.
2 Flashes	There is a bad connection on the left motor.	Check the left motor connections and wiring harnesses.
3 Flashes	The left motor has a short to a battery connection.	Contact your authorized Pride Provider.
4 Flashes	There is a bad connection on the right motor.	Check the right motor connections and wiring harnesses.
5 Flashes	The right motor has a short to a battery connection.	Contact your authorized Pride Provider.
6 Flashes	The charge inhibit has been activated.	Make sure that the battery charger is not connected to the power base.
7 Flashes	There is a joystick fault.	Make sure the joystick is in the center position and then power off and on again.
8 Flashes	There is a control system fault.	Check power module and joystick module connections and wiring.
9 Flashes	The park brakes have a bad connection.	Check the left and right motor connections and wiring.
10 Flashes	An excessive voltage has been applied to the control system.	Check the battery connections.

CARE AND MAINTENANCE

Refer to your power chair owner's manual for proper cleaning and disposal instructions.

WARRANTY

For two (2) years from the date of purchase, Pride will repair or replace at our option to the original purchaser, free of charge, the controller or any of its components found upon examination by an authorized representative of Pride to be defective in material and/or workmanship.

NOTES

NOTES

NOTES



Pride Mobility Products Corporation

182 Susquehanna Avenue
Exeter, PA 18643-2694
USA

Pride Mobility Products Company

380 Vansickle Road Unit 350
St. Catharines, Ontario L2R 6P7
Canada

Pride Mobility Products Ltd.

32 Wedgwood Road
Bicester, Oxon OX26 4UL
UK

Pride Mobility Products Australia Pty. Ltd.

21 Healey Road
Dandenong, 3175
Victoria, Australia

Pride Mobility Products Italia S.r.l.

Via del Progresso - ang. Via del Lavoro
Loc. Prato della Corte
00065-Fiano Romano (RM)

Pride Mobility Products Europe B.V.

Castricummer Werf 26
1901 RW Castricum
The Netherlands

www.pridemobility.com www.prideservice.com www.quantumrehab.com

