

Nutron[®] Series

**R50[™] LX, R51[™] ,
R51_{LX}, R51_{LXP}**

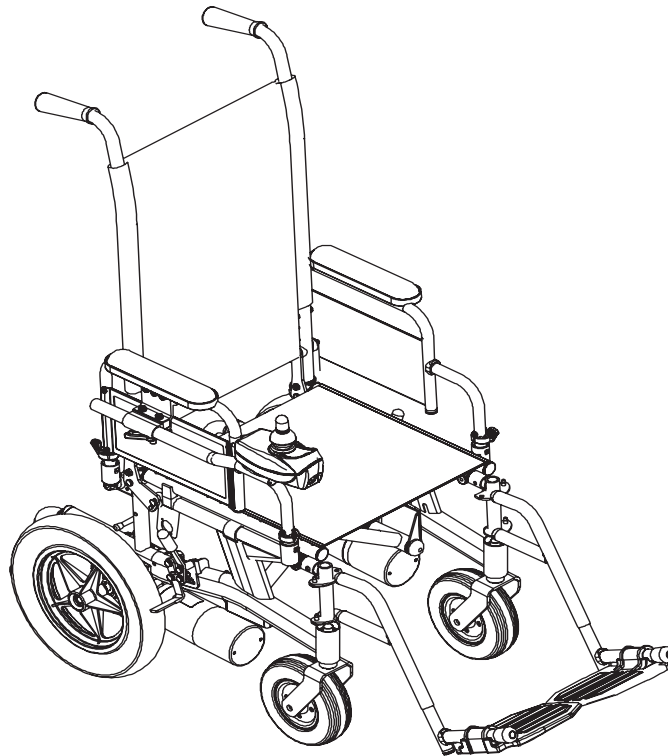

DEALER: This manual **MUST** be given to the user of the wheelchair.

USER: **BEFORE** using this wheelchair, read this manual and save for future reference.

For more information regarding Invacare products, parts, and services, please visit www.invacare.com



Yes, you can.™

⚠ WARNING

A QUALIFIED TECHNICIAN MUST PERFORM THE INITIAL SET UP OF THIS WHEELCHAIR. ALSO, A QUALIFIED TECHNICIAN MUST PERFORM ALL PROCEDURES IN THE SERVICE MANUAL.

WHEELCHAIR USERS: DO NOT SERVICE OR OPERATE THIS EQUIPMENT WITHOUT FIRST READING AND UNDERSTANDING (1) THE OWNER'S OPERATOR AND MAINTENANCE MANUAL AND (2) THE SEATING SYSTEM'S MANUAL (IF APPLICABLE). IF YOU ARE UNABLE TO UNDERSTAND THE WARNINGS, CAUTIONS, AND INSTRUCTIONS, CONTACT INVACARE TECHNICAL SUPPORT BEFORE ATTEMPTING TO SERVICE OR OPERATE THIS EQUIPMENT - OTHERWISE INJURY OR DAMAGE MAY RESULT.

DEALERS AND QUALIFIED TECHNICIANS: DO NOT SERVICE OR OPERATE THIS EQUIPMENT WITHOUT FIRST READING AND UNDERSTANDING (1) THE OWNER'S OPERATOR AND MAINTENANCE MANUAL, (2) THE SERVICE MANUAL (IF APPLICABLE) AND (3) THE SEATING SYSTEM'S MANUAL (IF APPLICABLE). IF YOU ARE UNABLE TO UNDERSTAND THE WARNINGS, CAUTIONS AND INSTRUCTIONS, CONTACT INVACARE TECHNICAL SUPPORT BEFORE ATTEMPTING TO SERVICE OR OPERATE THIS EQUIPMENT - OTHERWISE, INJURY OR DAMAGE MAY RESULT.

NOTE: Updated versions of this manual are available on www.invacare.com.

TABLE OF CONTENTS

REGISTER YOUR PRODUCT	6
SPECIAL NOTES	9
TYPICAL PRODUCT PARAMETERS	10
SECTION 1—GENERAL GUIDELINES	11
Repair or Service Information	11
Operating Information.....	11
Tire Pressure	12
Electrical Accessories	12
Grounding Instructions	13
Batteries.....	13
Charging Batteries	13
Rain Test.....	14
Weight Training	14
Weight Limitation.....	14
SECTION 2—EMI INFORMATION	15
SECTION 3—SAFETY/HANDLING OF WHEELCHAIRS	17
Safety/Handling of Wheelchairs.....	17
Stability and Balance.....	17
Coping With Everyday Obstacles.....	17
A Note to Wheelchair Assistants.....	18
Tilting.....	18
Tilting - Curbs.....	18
Stairways.....	19
Escalators	20
Transferring To and From Other Seats	20
Percentage of Weight Distribution	21
Reaching, Leaning and Bending - Forward	21
Reaching and Bending - Backward	22
SECTION 4—SAFETY INSPECTION/TROUBLESHOOTING	23
Safety Inspection Checklists.....	23
Inspect/Adjust Initially	23
Inspect/Adjust Weekly.....	24
Inspect/Adjust Monthly.....	24
Inspect/Adjust Periodically.....	24
Troubleshooting Guide.....	25
Checking Battery Charge Level.....	26

TABLE OF CONTENTS

SECTION 5—WHEELCHAIR OPERATION	27
Operating the Wheelchair.....	27
Turning the Power On/Off.....	27
Using the Joystick to Drive the Chair	28
Using the Horn.....	28
SPJ™ Joystick Switches and Indicators	29
Multi-Function Charger Port.....	29
On/Off Toggle Switch	29
Speed Control Knob	29
Joystick.....	29
Information Gauge Display	29
SECTION 6—FRONT RIGGINGS	31
Installing/Removing the Footrests.....	31
Installing.....	31
Removing	31
Adjusting the Footrest Height.....	32
Model PW93, PW93E, and PW93ST Footrests	32
Model 93M, 904A, PAL4A, and PAS4A Footrests	33
Replacing Heel Loops	33
Installing/Removing Elevating Legrests.....	34
Installing.....	34
Removing	34
Raising/Lowering Elevating Legrests and/or Adjusting Calfpads	34
Raising/Lowering Elevating Legrests	34
Adjusting Calfpads.....	35
Adjusting/Replacing Telescoping Front Rigging Support	35
SECTION 7—ARMS	37
Adjusting Armrest Height.....	37
Using Swing-Back Arms.....	38
Replacing Desk/Full Length Armrest Pad and/or Clothing Guards (Fixed Height Arms Only).	
38	
Armrest Pad	38
Clothing Guard.....	38
Removing/Installing Armrest.....	39
Removing	39
Installing.....	39
SECTION 8—BACK	40
Adjusting the Back Height	40
Using the Fold Down Back Canes (R5I, 5ILX and R5ILXP Models Only)	41

TABLE OF CONTENTS

Changing the Back Angle	41
SECTION 9—UPHOLSTERY/SEAT POSITIONING STRAP	43
Replacing Seat Upholstery	43
Replacing Back Upholstery	43
Replacing Seat Positioning Strap	44
SECTION 10—JOYSTICK	46
Preparing the Joystick For Use.....	46
Repositioning the Joystick.....	47
SECTION 11—CASTERS	48
Adjusting Forks	48
SECTION 12—BATTERIES	49
Warnings for Handling and Replacing Batteries	49
Using the Proper Batteries.....	49
Recommended Battery Types	50
Installing/Removing the Battery Boxes	51
Installing/Removing the Battery Tray	52
Installing/Removing the Batteries Into/From the Battery Boxes	53
Connecting Battery Cables	55
Direct Mount Method.....	55
Battery Clamp Method	58
Replacing the Battery Box Retaining Strap.....	61
Cleaning Battery Terminals	62
Charging Batteries	63
When To Charge Batteries	63
Description and Use of Battery Chargers.....	64
Connecting the Battery Charger	64
SECTION 13—CLUTCH/MOTOR LOCK	65
Engaging/Disengaging the Clutches.....	65
Disengaging/Engaging the Motor Lock Levers - R51LXP Only	66
Four Pole Motors.....	66
SECTION 14—WHEEL LOCKS	67
Installing/Adjusting/Using the Wheel Locks	67
Installing/Adjusting	67
Using	68
SECTION 15—ANTI-TIPPERS	69

TABLE OF CONTENTS

Installing/Removing the Anti-Tippers.....	69
Installing.....	69
Removing	69
SECTION 16—TRANSPORTING	71
Transporting the Nutron.....	71
Unfolding/Folding the Wheelchair	71
Unfolding	71
Folding	71
LIMITED WARRANTY	75

REGISTER YOUR PRODUCT

The benefits of registering:

1. Safeguard your investment.
2. Ensure long term maintenance and servicing of your purchase.
3. Receive updates with product information, maintenance tips, and industry news.
4. Invacare can contact you or your provider, if servicing is needed on your product.
5. It will enable Invacare to improve product designs based on your input and needs.

Register ONLINE at www.invacare.com

- or -

Complete and mail the form on the next page

Any registration information you submit will be used by Invacare Corporation only, and protected as required by applicable laws and regulations.



PRODUCT REGISTRATION FORM

Register **ONLINE** at www.invacare.com - or -
Complete and mail this form

Name _____

Address _____

City _____ State/Province _____

Zip/Postal Code _____

Email _____ Phone No. _____

Fold
here

Invacare Model No. _____ Serial No. _____

Purchased From _____ Date of Purchase: _____

1. Method of purchase: (check all that apply)

Medicare Insurance Medicaid Other _____

2. This product was purchased for use by: (check one)

Self Parent Spouse Other

3. Product was purchased for use at:

Home Facility Other

4. I purchased an Invacare product because:

Price Features (list features) _____

5. Who referred you to Invacare products? (check all that apply)

Doctor Therapist Friend Relative Dealer/Provider Other _____

Advertisement (circle one): TV, Radio, Magazine, Newspaper No Referral _____

6. What additional features, if any, would you like to see on this product?

Fold
here

7. Would you like information sent to you about Invacare products that may be available for a particular medical condition? Yes No

If yes, please list any condition(s) here and we will send you information by email and/or mail about any available Invacare products that may help treat, care for or manage such condition(s):

8. Would you like to receive updated information via email or regular mail about the Invacare home medical products sold by Invacare's dealers? Yes No

9. What would you like to see on the Invacare website?

10. Would you like to be part of future online surveys for Invacare products? Yes No

11. User's Year of birth: _____

If at any time you wish not to receive future mailings from us, please contact us at Invacare Corporation, CRM Department, 39400 Taylor Parkway, Elyria, OH 44035, or fax to 877-619-7996 and we will remove you from our mailing list.

To find more information about our products, visit www.invacare.com.

Cut Along Line



Fold
here

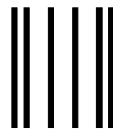

BUSINESS REPLY MAIL
FIRST-CLASS MAIL PERMIT NO. 196 ELYRIA OH

POSTAGE WILL BE PAID BY ADDRESSEE

NO POSTAGE
NECESSARY
IF MAILED
IN THE
UNITED STATES

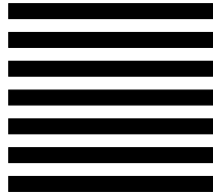

INVACARE CORPORATION
CRM DEPARTMENT
39400 TAYLOR PARKWAY
ELYRIA OH 44035-9836



Fold
here

Invacare Product Registration Form

Please Seal with
Tape Before Mailing

Cut Along Line



SPECIAL NOTES

WARNING/CAUTION notices as used in this manual apply to hazards or unsafe practices which could result in personal injury or property damage.

NOTICE

THE INFORMATION CONTAINED IN THIS DOCUMENT IS SUBJECT TO CHANGE WITHOUT NOTICE.

WHEELCHAIR USER

As a manufacturer of wheelchairs, Invacare endeavors to supply a wide variety of wheelchairs to meet many needs of the end user. However, final selection of the type of wheelchair to be used by an individual rests solely with the user and his/her healthcare professional capable of making such a selection.

WHEELCHAIR TIE-DOWN RESTRAINTS AND SEAT RESTRAINTS

Wheelchair users should **NOT** be transported in vehicles of any kind while in wheelchairs. As of this date, the Department of Transportation has not approved any tie-down systems for transportation of a user while in a wheelchair, in a moving vehicle of any type.

It is Invacare's position that users of wheelchairs should be transferred into appropriate seating in vehicles for transportation and use be made of the restraints made available by the auto industry. Invacare cannot and does not recommend any wheelchair transportation systems.

TYPICAL PRODUCT PARAMETERS

NUTRON R50LX, R5I, R5ILX, R5ILXP	
SEAT WIDTH RANGE	14, 16, 18 or 20 inches
SEAT DEPTH RANGE	16, 17 or 18 inches (17 and 18 in. by extension)
BACK HEIGHT RANGE STANDARD	16, 17 or 18 inches
SEAT-TO-FLOOR	17¾ or 19¾ inches
OVERALL WIDTH	21¾ inches to 27¾ inches (With joystick)
OVERALL HEIGHT LOW SEAT ADULT	33¾ inches to 37¾ inches 35¾ inches to 39¾ inches
OVERALL LENGTH	36½ inches to 47¼ inches
WEIGHT W/O BATTERIES AND FRONT RIGGINGS W/ BATTERIES AND PW93 FRONT RIGGINGS UI GEL CELL (14-INCH CHAIRS) 22NF GEL CELL (16, 18 OR 20 INCH CHAIRS) SHIPPING	82 pounds 145 pounds 110 pounds 157 pounds 128 pounds
DRIVE WHEELS/TIRES (FLAT FREE OR PNEUMATIC)	12½ inches x 2¼ inches
CASTERS W/PRECISION SEALED BEARINGS	8 x 1¾ inches semi pneumatic (standard) 8 x 2 inches pneumatic (optional) 6 x 2 inches semi pneumatic (optional)
ANTI-TIPPERS	Rotating, removable (standard)
FOOTREST/LEGREST	Swingaway, removable
ARMRESTS FIXED HEIGHT ADJUSTABLE HEIGHT	Desk and full length (standard) Desk and full length (optional)
UPHOLSTERY	Black nylon
BATTERIES BATTERY/SIZE (NOT SUPPLIED) TWO (2) REQUIRED	UI gel cell 22NF gel cell (not available on 14-inch wide wheel-chairs)
SPEED (M.P.H.)	0 to 4 (R50LX, R5I, R5ILX) or 0 to 6 (R5ILXP)
TURNING RADIUS	35 inches
*RANGE (VARIABLE)	12 - 14 miles with UI batteries 18 - 22 miles with 22NF batteries
**WEIGHT LIMITATION R50LX, R5I, R5ILX R5ILXP	250 lbs. 300 lbs.

*NOTE: Range will vary with battery conditions, surface, terrain and operating weight.

**NOTE: Includes seating system and accessories.

SECTION I—GENERAL GUIDELINES

Repair or Service Information

Set-up of the Electronic Control Unit is to be performed ONLY by individuals certified by Invacare. The final adjustments of the controller may affect other activities of the wheelchair. Damage to the equipment could occur under these circumstances. If non-certified individuals perform any work on these units, the warranty is void.

Operating Information

Performance adjustments should only be made by professionals of the healthcare field or persons fully conversant with this process and the driver's capabilities. Incorrect settings could cause injury to the driver, bystanders, damage to the chair and to surrounding property.

After the wheelchair has been set-up, check to make sure that the wheelchair performs to the specifications entered during the set-up procedure. If the wheelchair does not perform to specifications, turn the wheelchair off immediately and re-enter set-up specifications. Repeat this procedure until the wheelchair performs to specifications.

DO NOT shift your weight or sitting position toward the direction you are reaching as the wheelchair may tip over.

DO determine and establish your particular safety limits by practicing bending, reaching and transferring activities in the presence of a qualified healthcare professional BEFORE attempting active use of the wheelchair.

DO NOT attempt to reach objects if you have to move forward in the seat.

DO NOT attempt to reach objects if you have to pick them up from the floor by reaching down between your knees.

DO NOT lean over the top of the back upholstery to reach objects from behind as this may cause the wheelchair to tip over.

DO NOT use an escalator to move a wheelchair between floors. Serious bodily injury may occur.

Before attempting to transfer in or out of the wheelchair, every precaution should be taken to reduce the gap distance. Turn both casters parallel to the object you are transferring onto. Also be certain the power is off and the wheel locks are engaged to prevent the wheels from moving.

DO NOT engage or disengage the motor release levers until the power is in the off position.

Invacare strongly recommends proceeding down ramps or slopes at half speed or slower and to avoid hard braking or sudden stops.

DO NOT attempt to lift the wheelchair by lifting on any removable (detachable) parts. Lifting by means of any removable (detachable) parts of a wheelchair may result in injury to the user or damage to the wheelchair.

ALWAYS wear your seat positioning strap.

The seat positioning strap is a positioning belt only. It is not designed for use as a safety device withstanding high stress loads such as auto or aircraft safety belts. If signs of wear appear, belt MUST be replaced immediately.

Before performing any maintenance, adjustment or service verify that the ON/OFF switch on the joystick is in the off position.

Invacare products are specifically designed and manufactured for use in conjunction with Invacare accessories. Accessories designed by other manufacturers have not been tested by Invacare and are not recommended for use with Invacare products.

Avoid storage or use near external flame or combustible products.

DO NOT engage or disengage the motor locks/clutches until the power is in the OFF position.

DO NOT operate on roads, streets or highways.

DO NOT climb, go up or down ramps or traverse slopes greater than 9°.

DO NOT attempt to move up or down an incline with a water, ice or oil film.

DO NOT attempt to drive over curbs or obstacles. Doing so may cause your wheelchair to turn over and cause bodily harm or damage to the chair.

DO NOT leave the power button in the on position when entering or exiting your wheelchair.

DO NOT stand on the frame of the wheelchair.

DO NOT use the footplates as a platform. When getting in or out of the wheelchair, make sure that the footplates are in the upward position or swing footrests towards the outside of the chair.

Anti-tippers MUST be used at all times. When outdoors on wet, soft ground or gravel surfaces, anti-tippers may not provide the same level of protection against tipover. Extra caution must be observed when traversing such surfaces.

Tire Pressure

DO NOT use your wheelchair unless it has the proper tire pressure (p.s.i.). DO NOT overinflate the tires. Failure to follow these suggestions may cause the tire to explode and cause bodily harm. The recommended tire pressure is listed on the side wall of the tire.

Electrical Accessories

EXTREME care should be exercised when using oxygen in close proximity to electric circuits. Contact your oxygen supplier for instruction in the use of oxygen.

Grounding Instructions

DO NOT, under any circumstances, cut or remove the round grounding prong from any plug used with or for Invacare products. Some devices are equipped with three-prong (grounding) plugs for protection against possible shock hazards. Where a two-prong wall receptacle is encountered, it is the personal responsibility and obligation of the customer to contact a qualified electrician and have the two-prong receptacle replaced with a properly grounded three-prong wall receptacle in accordance with the National Electrical Code. If you must use an extension cord, use only a three-wire extension cord having the same or higher electrical rating as the device being connected. In addition, Invacare has placed RED/ORANGE WARNING TAGS on some equipment. DO NOT remove these tags.

Batteries

The warranty and performance specifications contained in this manual are based on the deep cycle gel cell batteries. Invacare strongly recommends their use as the power source for this unit.

Carefully read battery/battery charger information prior to installing, servicing or operating your wheelchair.

Charging Batteries

NEVER attempt to recharge the batteries by attaching cables directly to the battery terminals.

DO NOT attempt to recharge the batteries and operate the wheelchair at the same time.

DO NOT operate wheelchair with extension cord attached to the AC cable.

DO NOT attempt to recharge the batteries when the wheelchair has been exposed to any type of moisture.

DO NOT attempt to recharge the batteries when the wheelchair is outside.

DO NOT sit in the wheelchair while charging the batteries.

READ and CAREFULLY follow the manufacturer's instructions for each charger (supplied or purchased). If charging instructions are not supplied, consult a qualified technician for proper procedures.

After charging batteries, ALWAYS make sure that the battery charger cord is unplugged. Failure to do this could result in damage to the cord or personal injury to the user or bystanders.

Use of improper extension cord could result in risk of fire and electric shock.

When using an extension cord, use only a three (3) wire extension cord having at least 16 AWG (American Wire Gauge) wire and the same or higher electrical rating as the device being connected. Use of improper extension cord could result in risk of fire and electric shock.

Ensure the pins of the extension cord plug are the same number, size, and shape as those on the charger.

DO NOT under any circumstances cut or remove the round grounding plug from the charger AC cable plug or the extension cord plug.

Three (3) prong to two (2) prong adapters should not be used. Use of three (3) prong adapters can result in improper grounding and present a shock hazard to the user.

Rain Test

Invacare has tested its power wheelchairs in accordance with ISO 7176 Part 9 “Rain Test”. This provides the end user or his/her attendant sufficient time to remove his/her power wheelchair from a rain storm and retain wheelchair operation.

DO NOT leave power wheelchair in a rain storm of any kind.

DO NOT use power wheelchair in a shower or leave it in a damp bathroom while taking a shower.

DO NOT leave power wheelchair in a damp area for any length of time.

Direct exposure to rain or dampness will cause the chair to malfunction electrically and mechanically; may cause the chair to prematurely rust.

Check to ensure that the battery covers are secured in place, joystick boot is not torn or cracked where water can enter and that all electrical connections are secure at all times.

DO NOT use the joystick if the boot is torn or cracked. If the joystick boot becomes torn or cracked, replace immediately.

Weight Training

Invacare DOES NOT recommend the use of its wheelchairs as a weight training apparatus. Invacare wheelchairs have not been designed or tested as a seat for any kind of weight training. If occupant uses said wheelchair as a weight training apparatus, Invacare shall not be liable for bodily injury, and the warranty is void.

Weight Limitation

The Nutron R50LX, R51 and R51LX have a weight limitation, including the seating system, of 250 lbs. The Nutron R51LXP has a weight limitation of 300 lbs. Refer to Percentage of Weight Distribution on page 21.

Invacare recommends that only heavy-duty wheelchairs be used for individuals weighing more than 250 lbs. Further, the activity level of the individual wheelchair user is important. For instance, a 170 lbs active wheelchair user could subject the wheelchair to more stress than a 250 lbs user. Invacare recommends that very active users consider using heavy-duty wheelchairs.

SECTION 2—EMI INFORMATION

⚠ WARNING

CAUTION: IT IS VERY IMPORTANT THAT YOU READ THIS INFORMATION REGARDING THE POSSIBLE EFFECTS OF ELECTROMAGNETIC INTERFERENCE ON YOUR POWERED WHEELCHAIR.

Electromagnetic Interference (EMI) From Radio Wave Sources

Powered wheelchairs and motorized scooters (in this text, both will be referred to as powered wheelchairs) may be susceptible to electromagnetic interference (EMI), which is interfering electromagnetic energy (EM) emitted from sources such as radio stations, TV stations, amateur radio (HAM) transmitters, two way radios, and cellular phones. The interference (from radio wave sources) can cause the powered wheelchair to release its brakes, move by itself, or move in unintended directions. It can also permanently damage the powered wheelchair's control system. The intensity of the interfering EM energy can be measured in volts per meter (V/m). Each powered wheelchair can resist EMI up to a certain intensity. This is called its "immunity level." The higher the immunity level, the greater the protection. At this time, current technology is capable of achieving at least a 20 V/m immunity level, which would provide useful protection from the more common sources of radiated EMI.

There are a number of sources of relatively intense electromagnetic fields in the everyday environment. Some of these sources are obvious and easy to avoid. Others are not apparent and exposure is unavoidable. However, we believe that by following the warnings listed below, your risk to EMI will be minimized.

The sources of radiated EMI can be broadly classified into three types:

- 1) Hand-held Portable transceivers (transmitters-receivers with the antenna mounted directly on the transmitting unit. Examples include: citizens band (CB) radios, "walkie talkie", security, fire and police transceivers, cellular telephones, and other personal communication devices).

NOTE: Some cellular telephones and similar devices transmit signals while they are ON, even when not being used.

- 2) Medium-range mobile transceivers, such as those used in police cars, fire trucks, ambulances and taxis. These usually have the antenna mounted on the outside of the vehicle; and
- 3) Long-range transmitters and transceivers, such as commercial broadcast transmitters (radio and TV broadcast antenna towers) and amateur (HAM) radios.

NOTE: Other types of hand-held devices, such as cordless phones, laptop computers, AM/FM radios, TV sets, CD players, cassette players, and small appliances, such as electric shavers and hair dryers, so far as we know, are not likely to cause EMI problems to your powered wheelchair.

⚠ WARNING**Powered Wheelchair Electromagnetic Interference (EMI)**

Because EM energy rapidly becomes more intense as one moves closer to the transmitting antenna (source), the EM fields from hand-held radio wave sources (transceivers) are of special concern. It is possible to unintentionally bring high levels of EM energy very close to the powered wheelchair's control system while using these devices. This can affect powered wheelchair movement and braking. Therefore, the warnings listed below are recommended to prevent possible interference with the control system of the powered wheelchair.

Electromagnetic interference (EMI) from sources such as radio and TV stations, amateur radio (HAM) transmitters, two-way radios, and cellular phones can affect powered wheelchairs and motorized scooters.

FOLLOWING THE WARNINGS LISTED BELOW SHOULD REDUCE THE CHANCE OF UNINTENDED BRAKE RELEASE OR POWERED WHEELCHAIR MOVEMENT WHICH COULD RESULT IN SERIOUS INJURY.

- 1) Do not operate hand-held transceivers (transmitters receivers), such as citizens band (CB) radios, or turn ON personal communication devices, such as cellular phones, while the powered wheelchair is turned ON;
- 2) Be aware of nearby transmitters, such as radio or TV stations, and try to avoid coming close to them;
- 3) If unintended movement or brake release occurs, turn the powered wheelchair OFF as soon as it is safe;
- 4) Be aware that adding accessories or components, or modifying the powered wheelchair, may make it more susceptible to EMI (NOTE: There is no easy way to evaluate their effect on the overall immunity of the powered wheelchair); and
- 5) Report all incidents of unintended movement or brake release to the powered wheelchair manufacturer, and note whether there is a source of EMI nearby.

Important Information

- 1) 20 volts per meter (V/m) is a generally achievable and useful immunity level against EMI (as of May 1994) (the higher the level, the greater the protection);
- 2) The immunity level of the product is unknown.

Modification of any kind to the electronics of this wheelchair as manufactured by Invacare may adversely affect the RFI immunity levels.

SECTION 3—SAFETY/HANDLING OF WHEELCHAIRS

Safety/Handling of Wheelchairs

“Safety and Handling” of the wheelchair requires the close attention of the wheelchair user as well as the assistant. This manual points out the most common procedures and techniques involved in the safe operation and maintenance of the wheelchair. It is important to practice and master these safe techniques until you are comfortable in maneuvering around the frequently encountered architectural barriers.

Use this information only as a “basic” guide. The techniques that are discussed on the following pages have been used successfully by many.

Individual wheelchair users often develop skills to deal with daily living activities that may differ from those described in this manual. Invacare recognizes and encourages each individual to try what works best for him/her in overcoming architectural obstacles that they may encounter, however, ALL WARNINGS and CAUTIONS given in this manual MUST be followed. Techniques in this manual are a starting point for the new wheelchair user and assistant with “safety” as the most important consideration for all.

Stability and Balance

WARNING

ALWAYS wear your seat positioning strap.

The seat positioning strap is a positioning belt only. It is not designed for use as a safety device withstanding high stress loads such as auto or aircraft safety belts. If signs of wear appear, the belt must be replaced immediately.

To assure stability and proper operation of your wheelchair, you must at all times maintain proper balance. Your wheelchair has been designed to remain upright and stable during normal daily activities as long as you do not move beyond the center of gravity. DO NOT lean forward out of the wheelchair any further than the length of the armrests.

Coping With Everyday Obstacles

Coping with the irritation of everyday obstacles can be alleviated somewhat by learning how to manage your wheelchair. Keep in mind your center of gravity to maintain stability and balance.

A Note to Wheelchair Assistants

When assistance to the wheelchair user is required, remember to use good body mechanics. Keep your back straight and bend your knees whenever tilting wheelchair or traversing curbs, or other impediments.

⚠ WARNING

DO NOT attempt to lift the wheelchair by any removable (detachable) parts. Lifting by means of any removable (detachable) parts of a wheelchair may result in injury to the user or damage to the wheelchair.

Also, be aware of detachable parts such as arms or leg-rests. These must NEVER be used for hand-hold or lifting supports, as they may be inadvertently released, resulting in possible injury to the user and/or assistant(s).

When learning a new assistance technique, have an experienced assistant help you before attempting it alone.

Tilting

⚠ WARNING

DO NOT tilt the wheelchair without assistance.

When tilting the wheelchair, an assistant should grasp the back of the wheelchair on a non-removable (non-detachable) part. Inform the wheelchair occupant before tilting the wheelchair and remind him/her to lean back. Be sure the occupant's feet and hands are clear of all wheels.

Tilting - Curbs

After mastering the techniques of tilting the wheelchair, use this procedure to tackle curbs, short stairs, etc.

This procedure requires two (2) assistants. The second assistant should be positioned at the front of the wheelchair lifting upward on a non-removable (non-detachable) part of the wheelchair frame when lifting the wheelchair and stabilizing the wheelchair when the wheelchair is being lowered to the ground.

The first assistant should turn the anti-tippers so the wheels are pointing up, apply a continuous downward motion until the balance point is achieved and the front casters clear the curb. At this point, the assistants will feel a difference in the weight distribution.

⚠ WARNING

DO NOT let the wheelchair drop the last few inches to the ground. This could result in injury to the occupant.

Anti-tippers MUST BE used at all times. When outdoors on wet, soft ground or gravel surfaces, anti-tippers may not provide the same level of protection against tipover. Extra caution must be observed when traversing such surfaces.

Roll the wheelchair forward and SLOWLY lower the wheelchair in one continuous movement. Push the wheelchair forward until the rear wheels roll up and over the curb.

⚠ WARNING

Make sure anti-tipper wheels are pointing down towards the ground/floor before using the wheelchair.

Turn the anti-tipper wheels down toward the ground/floor.

Stairways

⚠ WARNING

DO NOT attempt to move an occupied power wheelchair between floors using a stairway. Use an elevator to move an occupied power wheelchair between floors. If moving a power wheelchair between floors by means of a stairway, the occupant **MUST** be removed and transported independently of the power wheelchair.

Extreme caution is advised when it is necessary to move an unoccupied power wheelchair up or down the stairs. Invacare recommends using two (2) assistants and making thorough preparations. Make sure to use only secure, non-detachable parts for hand-hold supports.

DO NOT attempt to lift the wheelchair by any removable (detachable) parts. Lifting by means of any removable (detachable) parts of a wheelchair may result in injury to the user or damage to the wheelchair.

The weight of the wheelchair without the user and batteries is between 80 and 127 lbs. Use proper lifting techniques (lift with your legs) to avoid injury.

1. Remove the occupant from the wheelchair.
2. Remove the battery boxes from the wheelchair. Refer to [Installing/Removing the Battery Boxes](#) on page 51.
3. If necessary, fold the wheelchair. Refer to [Transporting the Nutron](#) on page 71.
4. Bend your knees and keep your back straight.
5. Using non-removable (non-detachable) parts of the wheelchair, lift the wheelchair off of the ground and transfer the wheelchair up or down the stairs.

- The wheelchair should not be lowered until the last stair has been negotiated and the wheelchair has been carried away from the stairway.

Escalators

⚠ WARNING

DO NOT use an escalator to move a wheelchair between floors. Serious bodily injury may occur.

Transferring To and From Other Seats

⚠ WARNING

ALWAYS turn the wheelchair power **OFF** and engage the clutches to prevent the wheels from moving **BEFORE** attempting to transfer in or out of the wheelchair. Also make sure every precaution is taken to reduce the gap distance by turning both casters parallel to the object you are transferring onto.

⚠ CAUTION

When transferring, position yourself as far back as possible in the seat. This will prevent broken screws, damaged upholstery and the possibility of the wheelchair tipping forward.

NOTE: For this procedure, refer to FIGURE 3.1.

NOTE: This activity may be performed independently provided you have adequate mobility and upper body strength.

- Position the wheelchair as close as possible along side the seat to which you are transferring, with the casters pointing parallel to it.
- Engage clutches. Refer to [Engaging/Disengaging the Clutches](#) on page 65.
- Shift body weight into seat with transfer.

During independent transfer, little or no seat platform will be beneath you. Use a transfer board if at all possible.

MINIMUM GAP DISTANCE

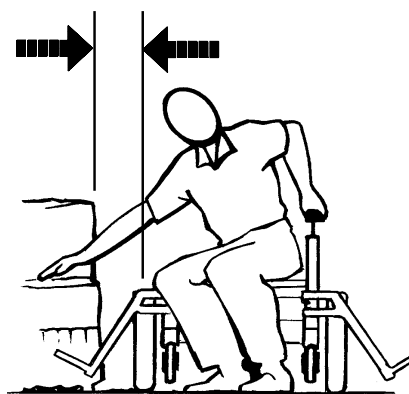

FIGURE 3.1 Transferring To and From Other Seats

Percentage of Weight Distribution

⚠ WARNING

DO NOT attempt to reach objects if you have to move forward in the seat or pick them up from the floor by reaching down between your knees.

Proper positioning is essential for your safety. When reaching, leaning, bending or bending forward, it is important to use the casters as a tool to maintain stability and balance.

Many activities require the wheelchair user to reach, bend and transfer in and out of the wheelchair. These movements will cause a change to the normal balance, center of gravity, and weight distribution of the wheelchair. To determine and establish your particular safety limits, practice bending, reaching and transferring activities in several combinations in the presence of a qualified healthcare professional before attempting active use of the wheelchair.

Reaching, Leaning and Bending - Forward

NOTE: For this procedure, refer to FIGURE 3.2.

1. Position the front casters as far forward as possible.
2. Engage clutches and, if applicable, wheel locks*.

⚠ WARNING

DO NOT attempt to reach objects if you have to move forward in the seat or pick them up from the floor by reaching down between your knees.

*Wheel locks are an option. You may order the wheelchair with or without wheel locks. Transfer to and from the wheelchair in the presence of a qualified healthcare professional to determine individual safety limits. Invacare strongly recommends ordering the wheel locks as an additional safeguard for the wheelchair user.

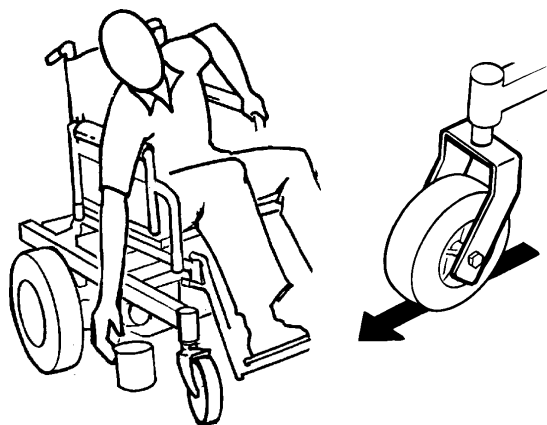

FIGURE 3.2 Reaching, Leaning and Bending - Forward

Reaching and Bending - Backward

⚠ WARNING

DO NOT lean over the top of the back upholstery. This will change your center of gravity and may cause you to tip over.

NOTE: For this procedure, refer to FIGURE 3.3.

1. Position wheelchair as close as possible to the desired object.
2. Point the front casters as far forward as possible to create the longest possible wheelbase.
3. Reach back only as far as your arm will extend without changing your sitting position.



FIGURE 3.3 Reaching and Bending - Backward

SECTION 4—SAFETY INSPECTION/TROUBLESHOOTING

NOTE: Every six (6) months or as necessary take your wheelchair to a qualified technician for a thorough inspection and servicing. Regular cleaning will reveal loose or worn parts and enhance the smooth operation of your wheelchair. To operate properly and safely, your wheelchair must be cared for just like any other vehicle. Routine maintenance will extend the life and efficiency of your wheelchair.

Safety Inspection Checklists

Initial adjustments should be made to suit your personal body structure needs and preference. Thereafter follow these maintenance procedures:

Inspect/Adjust Initially

- Ensure wheelchair rolls straight (no excessive drag or pull to one side).
- Ensure arms are secure but easy to release and adjustment levers engage properly.
- Ensure adjustable height arms operate and lock securely.
- Ensure arm pivot points are free of wear and looseness.
- Inspect seat and back upholstery for rips or sagging.
- Ensure armrest pads sit flush against arm tubes.
- Ensure seat release latch is functional. Replace if necessary.
- Ensure wheel mounting bolts are secure on drive wheels.
- Ensure no excessive side movement or binding when drive wheels are lifted and spun when disengaged (freewheeling).
- Ensure wheel/fork assembly has proper tension when caster is spun. Caster should come to a gradual stop.

△ CAUTION

As with any vehicle, wheels and tires should be checked periodically for cracks and wear and should be replaced as necessary.

- Loosen/tighten caster locknut if wheel wobbles noticeably or binds to a stop.
- Ensure all caster/wheel/fork/headtube fasteners are secure.
- Inspect tires for flat spots and wear.
- Clean upholstery and armrests.

Inspect/Adjust Weekly

- Inspect tires for flat spots and wear.

Inspect/Adjust Monthly

- Ensure arm pivot points are free of wear and looseness.
 - Ensure wheel mounting bolts are secure on drive wheels.
 - Ensure no excessive side movement or binding when drive wheels are lifted and spun when disengaged (free-wheeling).
 - Ensure wheel/fork assembly has proper tension when caster is spun. Caster should come to a gradual stop.
-

△ CAUTION

As with any vehicle, wheels and tires should be checked periodically for cracks and wear and should be replaced as necessary.

- Loosen/tighten caster locknut if wheel wobbles noticeably or binds to a stop.
- Ensure all caster/wheel/fork/headtube fasteners are secure.
- Inspect for any loose hardware on the wheelchair.
- Inspect seat positioning strap for any signs of wear. Ensure buckle latches. Verify hardware that attaches strap to frame is secure and undamaged. Replace if necessary.

Inspect/Adjust Periodically

- Ensure wheelchair rolls straight (no excessive drag or pull to one side).
- Ensure arms are secure but easy to release and adjustment levers engage properly.
- Ensure adjustable height arms operate and lock securely.
- Ensure armrest pads sit flush against arm tubes.
- Inspect seat and back upholstery for rips or sagging.
- Ensure seat release latch is not worn. Replace if necessary.
- Clean upholstery and armrests.
- Inspect the seat positioning strap for wear. Replace if worn or damaged.
- Inspect charger AC power cord for damage. Replace if necessary.

Troubleshooting Guide

SYMPTOM	PROBABLE CAUSE	SOLUTIONS
Batteries draw excessive current when charging.	Battery failure. Electrical malfunction.	Have batteries checked for shorted cell. Replace if necessary. Contact Dealer/Invacare for service.
Battery indicator flashes the charge level is low - immediately after recharge.	Battery failure. Malfunctioning battery charger. Electrical malfunction	Check batteries for shorted cell. Replace if necessary. Contact Dealer/Invacare for service. Contact Dealer/Invacare for service.
Battery indicator flashes the charge level is low - too soon after being recharged.	Batteries not charged. Weak batteries.	Have charger checked. Replace batteries if necessary. Contact Dealer/Invacare for service.
Motor “chatters” or runs irregular.	Electrical malfunction.	Contact Dealer/Invacare for service.
Joystick erratic or does not respond as desired.	Damaged motor coupling. Electrical malfunction. Controller programmed improperly.	Contact Dealer/Invacare for service. Contact Dealer/Invacare for service. Reprogram controller (Refer to MK5™ , EX™ or MK5 NX™ electronics owner’s manual supplied with wheelchair).
Wheelchair does not respond to commands.	Poor battery terminal connection.	Have terminals cleaned.
Power indicator off - even after recharging.	Electrical malfunction.	Contact Dealer/Invacare for service.

Checking Battery Charge Level

The following “Do’s” and “Don’ts” are provided for your convenience and safety.

DON'T	DO
Don't perform any installation or maintenance without first reading this manual.	Read and understand this manual and any service information that accompanies a battery and charger before operating the wheelchair.
Don't perform installation or maintenance of batteries in an area that could be damaged by battery spills.	Move the wheelchair to a work area before cleaning terminals, or opening battery box.
Don't make it a habit to discharge batteries to the lowest level.	Recharge as frequently as possible to maintain a high charge level and extend battery life.
Don't use randomly chosen batteries or chargers.	Follow recommendations in this manual when selecting a battery or charger.
Don't put new batteries into service before charging.	Fully charge a new battery before using.
Don't tip or tilt batteries.	Use a carrying strap to remove, move or install a battery.
Don't tap on clamps and terminals with tools.	Push battery clamps on the terminals. Spread clamps wider if necessary.
Don't mismatch your battery and chargers.	Use ONLY a GEL charger for a GEL battery.

SECTION 5—WHEELCHAIR OPERATION

⚠ WARNING

After **ANY** adjustments, repair or service and **BEFORE** use, make sure that all attaching hardware is tightened securely - otherwise injury or damage may result.

Set-up/programming of the Electronic Control Unit is to be performed **ONLY** by a qualified technician. The fine tuning adjustments of the controller may affect other activities of the wheelchair. Damage to the equipment could occur under these circumstances. **IF UNQUALIFIED INDIVIDUALS PERFORM ANY WORK ON THESE UNITS, THE WARRANTY IS VOID.**

Operating the Wheelchair

Turning the Power On/Off

NOTE: For this procedure, refer to FIGURE 5.1.

1. Turn the power on by moving the on/off switch up or down. The switch automatically retracts back to center position.

NOTE: After turning power on, all indicators will light briefly, and the display gauge will indicate one of the following:

- A. *The Current Battery Charge - Information gauge shows all LED's lit or partial LED's lit.*
 - B. *Out Of Neutral at Power Up - Information Gauge shows all LED's flashing slowly. This occurs when the power is turned on when the joystick is out of neutral. This feature prevents sudden and unexpected movements of the power chair.*
2. Turning the power off can be achieved by moving the on/off switch up or down. The switch automatically retracts back to center position.

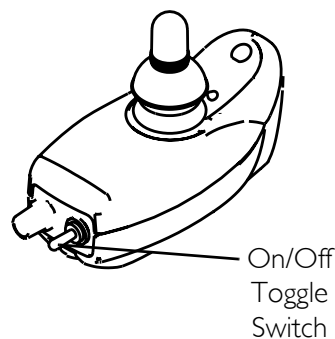
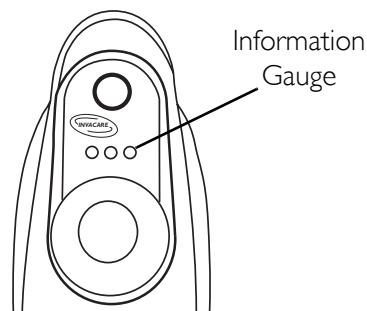

FIGURE 5.1 Operating the Wheelchair

Using the Joystick to Drive the Chair

NOTE: For this procedure, refer to FIGURE 5.2.

The joystick is located at the front of the joystick housing and provides smooth control of speed and direction. It is equipped with 360 degrees of mobility for ease of operation. The joystick is spring-loaded, and automatically returns to the upright (neutral) position when released. Pushing the joystick in a given direction causes the chair to move in that direction.

The joystick has proportional drive control, meaning that the further the joystick is pushed from the upright (neutral) position, the faster the wheelchair moves. The maximum speed, however, is limited by the setting of the speed control knob.

To slow the wheelchair to a stop, simply release the joystick. The wheelchair has automatic speed and direction compensation to minimize corrections.

When first learning to drive, select a SLOW speed and try to drive the wheelchair AS SLOWLY as possible by pushing the joystick slightly forward. This exercise will help you learn to utilize the full potential of the proportional control and allow you to start and stop smoothly.

To drive the wheelchair, perform the following:

1. Adjust speed control knob to the appropriate setting.
2. Turn the power on. Refer to [Turning the Power On/Off](#) on page 27.
3. Move the joystick in the following manner:

MOVEMENT	ACTION
FORWARD	Push forward on the joystick.
REVERSE	Pull back on the joystick.
Turn RIGHT	Move the joystick RIGHT.
Turn LEFT	Move the joystick LEFT.
STOP	Release the joystick and the wheelchair will quickly slow down.

Using the Horn

NOTE: For this procedure, refer to FIGURE 5.2.

1. Press the horn button located above the information gauge on the joystick housing.

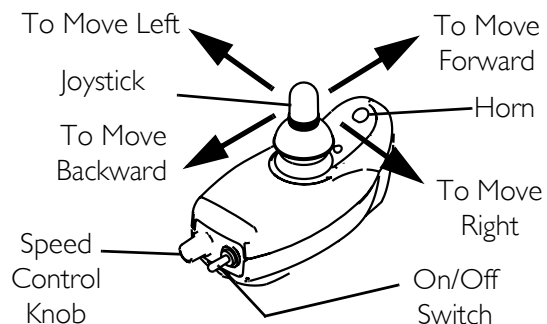

FIGURE 5.2 Using the Joystick to Drive the Chair

SPJ™ Joystick Switches and Indicators

NOTE: For the following information, refer to FIGURE 5.3.

Multi-Function Charger Port

Located at the front of the joystick housing. This provides easy access for charging the wheelchair batteries. This port also serves as the Remote Programmer Communication connection.

On/Off Toggle Switch

This toggle switch is located at the back of the joystick housing.

Speed Control Knob

The speed control knob is located on the back of the joystick housing. This rotary switch is used for controlling the speed and acceleration of the wheelchair.

1. Turn the knob clockwise to increase the speed of the wheelchair.
2. Turn the knob counterclockwise to decrease the speed of the wheelchair.

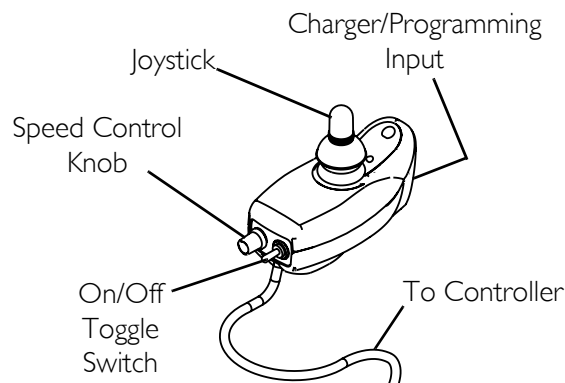

FIGURE 5.3 SPJ™ Joystick Switches and Indicators

Joystick

The joystick has proportional drive control, meaning that further the wheelchair is pushed from the upright (neutral) position, the faster it moves. Your top speed, however, is limited by the setting of the speed-control knob and programmed settings.

To slow the wheelchair to a stop, simply release the joystick. The wheelchair has automatic speed and direction compensation to minimize corrections.

Information Gauge Display

Located on the front of the joystick housing, it provides the following information to the user on the status of the wheelchair:

- Power is On.
- True state-of-battery-charge, including notification of when the battery requires charging:
 - A. GREEN LED is lit, indicating well charged batteries.
 - B. Only AMBER LEDs are lit, indicating batteries are moderately charged. Recharge batteries before taking a long trip.
 - C. Only RED LED is lit, indicating batteries are running out of charge. Recharge batteries as soon as possible.

The Information Gauge display also serves as a system diagnostic device when a fault is detected by the control module. A specific number of flashes of the LEDs indicates the type of fault detected. Refer to the following table of the diagnostic indications of the wheelchair status.

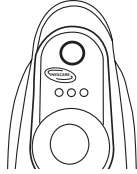
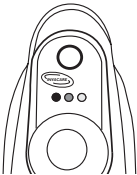
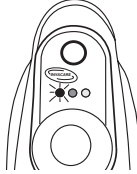
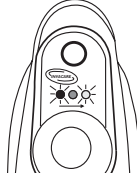
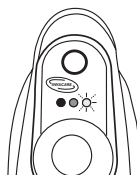
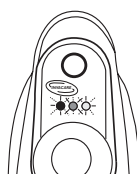
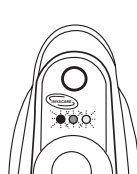
DISPLAY	DESCRIPTION	DEFINITION	COMMENTS
	All three (3) LEDs are off.	Power is Off.	
	All three (3) LEDs are on.	Power is On.	Fewer than three (3) LEDs on implies reduced battery charge.
	RED LED is flashing.	Battery charge is low.	The batteries should be charged as soon as possible.
	Left to Right “chase” alternating with steady display.	Joystick is in programming, inhibit and/or charging mode.	The steady LEDs indicate the current state of the battery charge.
	GREEN LED is flashing.	Joystick is in Speed Limit mode.	The current state of battery charge will be displayed at the same time.
	All LEDs are flashing slowly.	Joystick has detected Out-of-Neutral-at-Power-Up mode.	Release the joystick back to Neutral.
	All LEDs are flashing quickly.	Joystick has detected a fault.	Joystick uses Flash codes to indicate faults.

SECTION 6—FRONT RIGGINGS

⚠ WARNING

After **ANY** adjustments, repair or service and **BEFORE** use, make sure that all attaching hardware is tightened securely - otherwise injury or damage may result.

Installing/Removing the Footrests

NOTE: For this procedure, refer to FIGURE 6.1.

Installing

1. Turn footrest to the side (open footplate is perpendicular to wheelchair) and position mounting holes in the footrest hinge plates with hinge pins on the wheelchair frame.
2. Install the footrest hinge plates onto the hinge pins on the wheelchair frame.
3. Push the footrest towards the inside of the wheelchair until it locks into place.

NOTE: The footplate will be on the inside of the wheelchair when locked in place.

4. Repeat STEPS 1-3 for the opposite side of the wheelchair.

Removing

1. Push the footrest release lever inward and rotate the footrest outward.
2. Lift up on footrest and remove from the wheelchair.
3. Repeat STEPS 1-2 for the opposite side of the wheelchair.

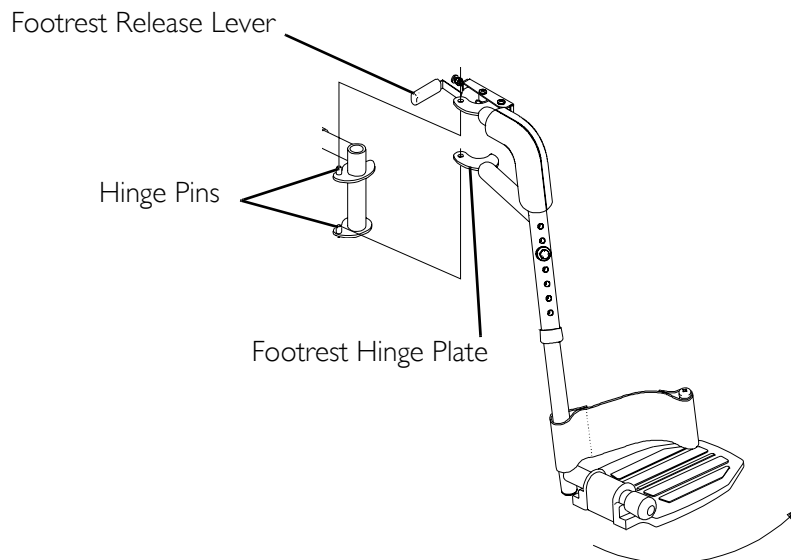

FIGURE 6.1 Installing/Removing the Footrests

Adjusting the Footrest Height

Model PW93, PW93E, and PW93ST Footrests

NOTE: For this procedure, refer to FIGURE 6.2.

1. Remove any accessory from the footrest(s).
2. Remove the footrest from the wheelchair. Refer to [Installing/Removing the Footrests](#) on page 31.

NOTE: Lay footrest on a flat surface to simplify procedure.

3. Remove the hex bolt, coved washers and locknut that secure the lower footrest to the footrest support.
4. Reposition the lower footrest to the desired height.
5. Reinstall hex bolt, coved washers and locknut that secure lower footrest to footrest support. Tighten securely.
6. Repeat STEPS 1-5 for the other footrest, if necessary.
7. Reinstall the footrest(s) onto the wheelchair. Refer to [Installing/Removing the Footrests](#) on page 31.
8. Reinstall any accessory onto the footrest(s).

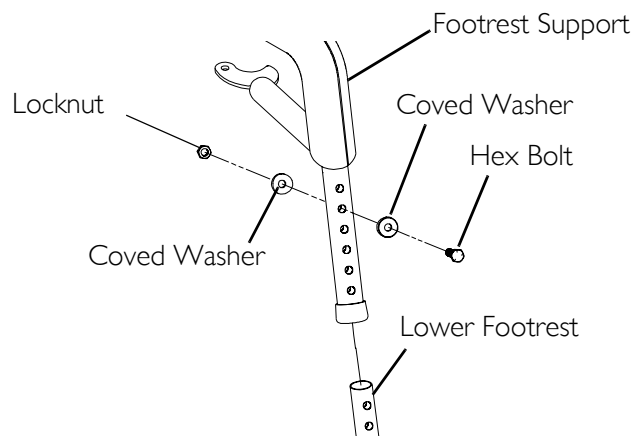

NOTE: PW93ST style footrest shown. PW93 and PW93E footrests adjust the same way.

FIGURE 6.2 Adjusting the Footrest Height - Model PW93, PW93E, and PW93ST Footrests

Model 93M, 904A, PAL4A, and PAS4A Footrests

NOTE: For this procedure, refer to FIGURE 6.3.

1. Loosen, but do not remove the lug bolt and locknut that secure the lower footrest to the footrest support.
2. Reposition the lower footrest to the desired height.
3. Securely tighten the lug bolt and locknut that secure the lower footrest to the footrest support.
4. Repeat STEPS 1-3 for the other footrest, if necessary.

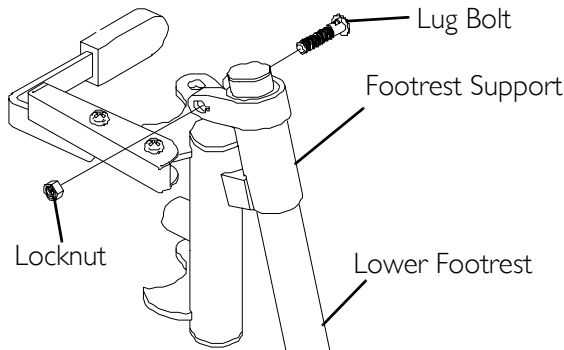

NOTE: 93M style footrest shown. 904A, PAL4A and PAS4A footrests adjust the same way.

FIGURE 6.3 Adjusting the Footrest Height - Model 93M, 904A, PAL4A, and PAS4A Footrests

Replacing Heel Loops

NOTE: For this procedure, refer to FIGURE 6.4.

1. Note the position of hex bolt, coved washers and locknut for reinstallation.
2. Remove the hex bolt, coved washers and locknut that secure the lower footrest to the footrest support.
3. Remove the lower footrest.
4. Remove the phillips bolt, spacer and locknut that secure the existing heel loop to the lower footrest.
5. Slide the existing heel loop off the lower footrest.
6. Replace heel loop.
7. Reverse STEPS 1-6 to reassemble.

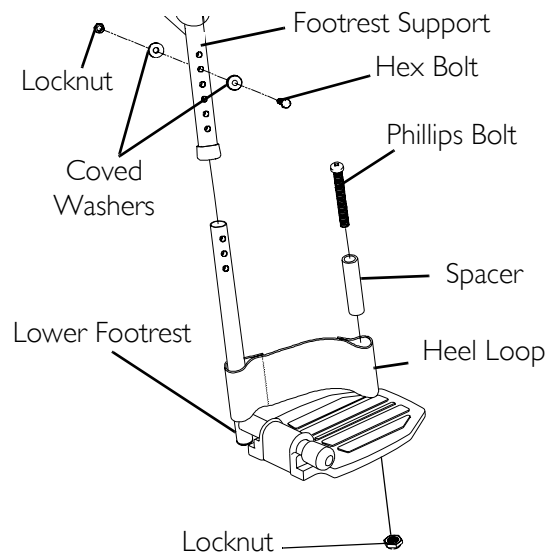

FIGURE 6.4 Replacing Heel Loops

NOTE: When securing heel loop to lower footrest, tighten the phillips screw and locknut until the spacer is secure.

Installing/Removing Elevating Legrests

NOTE: For this procedure, refer to FIGURE 6.5.

Installing

1. Turn legrest to side (open footplate is perpendicular to wheelchair) and position mounting holes in the legrest hinge plates with hinge pins on the wheelchair frame.
2. Install the legrest hinge plates onto the hinge pins on the wheelchair frame.
3. Rotate legrest toward the inside of the wheelchair until it locks in place.

NOTE: The footplate will be on the inside of the wheelchair when locked in place.

4. Repeat STEPS 1-3 for the other legrest.

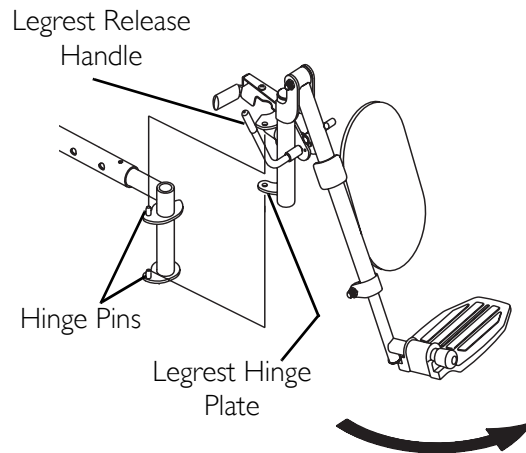

FIGURE 6.5 Installing/Removing Elevating Legrests

5. After seated in wheelchair, adjust footplate to correct height by loosening nut and sliding the lower footrest assembly up or down until desired height is achieved.

Removing

1. Push the legrest release handle toward the inside of the wheelchair (facing the front of the wheelchair) and swing the legrest to the outside of the wheelchair.
2. Lift up on the legrest and remove from the wheelchair.
3. Repeat STEPS 1-2 for the other legrest.

Raising/Lowering Elevating Legrests and/or Adjusting Calfpads

NOTE: For this procedure, refer to FIGURE 6.6.

Raising/Lowering Elevating Legrests

1. Perform one (1) of the following:
 - Raising - Pull back on the release lever until the leg is at the desired height.
 - Lowering - Support leg with one (1) hand. Push release lever downward with other hand.

Adjusting Calfpads

1. Turn calfpad towards the outside of the wheelchair.
2. Slide calfpad up or down until desired position is obtained.

NOTE: If one (1) of the top two (2) calfpad adjustment positions is being used, the legrest will need to be raised to avoid interference with the front stabilizers while going over obstacles or going up and down ramps. Refer to Raising/Lowering Elevating Legrests on page 34.

3. Turn the calfpad toward the inside of the wheelchair.

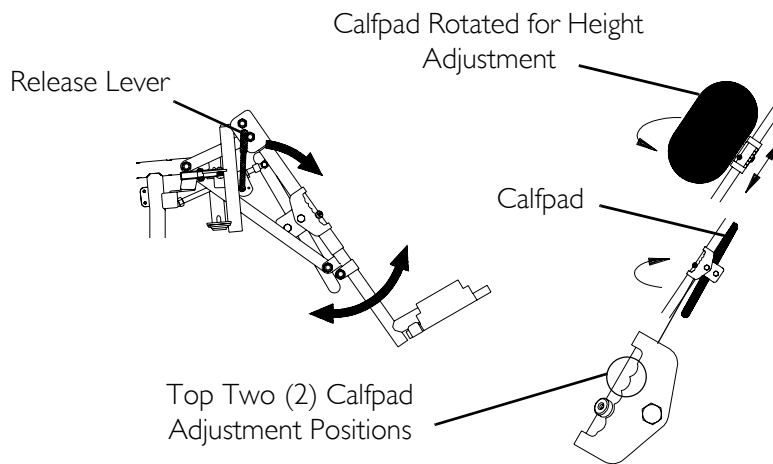

FIGURE 6.6 Raising/Lowering Elevating Legrests and/or Adjusting Calfpads

Adjusting/Replacing Telescoping Front Rigging Support

NOTE: For this procedure, refer to FIGURE 6.7.

NOTE: When adjusting the telescoping front rigging support depth, ensure the footplate does not interfere with the caster wheel rotation.

1. Lift up on the crossbraces until they release from the H-blocks on the wheelchair frame.
2. Remove the long socket bolt and locknut that secure the front H-block and spacer to the wheelchair frame and telescoping front rigging support.
3. Remove the front, and rear short socket bolts and the two (2) locknuts that secure telescoping front rigging support to wheelchair.

4. Perform one (1) of the following:

• Adjusting:

NOTE: Telescoping front rigging supports may be extended up to 2-inches from the wheelchair frame in 1-inch increments. This adjustment does not effect seat depth.

i. Position the telescoping front rigging support to the desired depth.

• Replacing:

i. Remove the existing telescoping front rigging support from the wheelchair frame.

ii. Insert the new telescoping front rigging support into the wheelchair frame.

iii. Position the telescoping front rigging support to the desired depth.

NOTE: The footplate will be on the inside of the wheelchair when locked in place.

5. Using the front and rear socket bolts and two (2) locknuts, secure the telescoping front rigging support to the wheelchair frame as shown in FIGURE 6.7.

6. Using the long socket bolt and locknut, secure the H-block and spacer to the wheelchair frame and the telescoping front rigging support as shown in FIGURE 6.7.

7. Snap crossbraces into H-blocks. Wiggle crossbraces to make sure they are secured in the H-blocks.

8. If necessary, repeat STEPS 1-8 on remaining telescoping front rigging support.

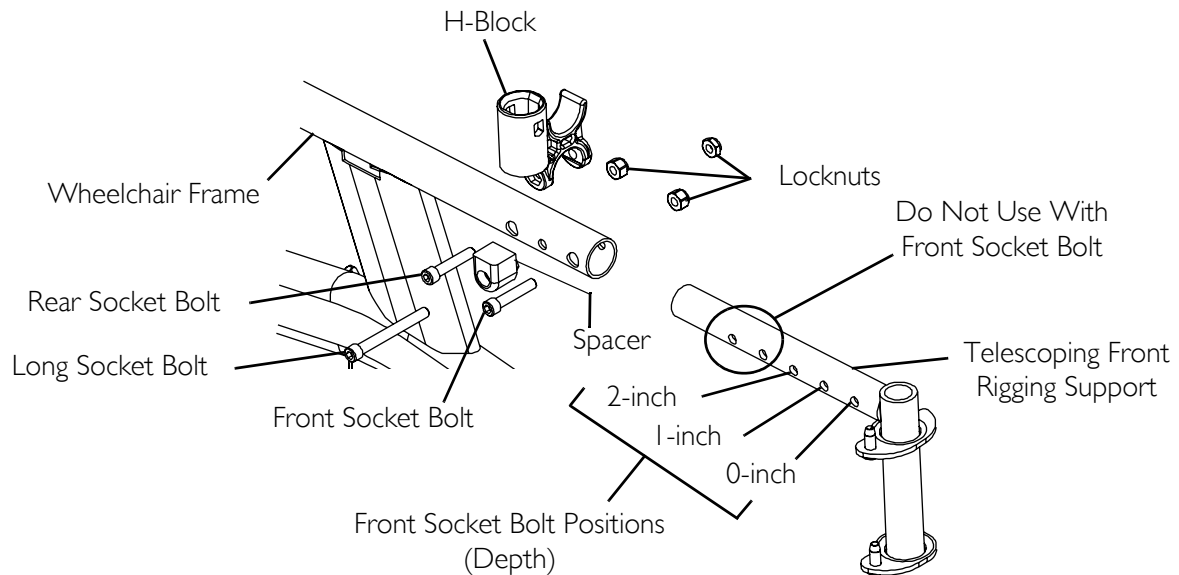

FIGURE 6.7 Adjusting/Replacing Telescoping Front Rigging Support

SECTION 7—ARMS

⚠ WARNING

After ANY adjustments, repair or service and BEFORE use, make sure all attaching hardware is tightened securely - otherwise injury or damage may result.

Adjusting Armrest Height

NOTE: For this procedure, refer to FIGURE 7.1.

⚠ WARNING

Make sure the height adjustment lever is in the locked position before using the wheelchair.

1. Unlock the armrest by flipping the height adjustment lever on the top front of the armrest to the up (horizontal) position.
2. Adjust armrest to one (1) of five (5) positions.

NOTE: Height adjustment lever MUST be in the unlocked position when placing armrest into the arm assembly.

3. Lock the armrest by pressing the height adjustment lever into the down (vertical) position when the desired armrest height is achieved.
4. Repeat STEPS 1-3 for other armrest.

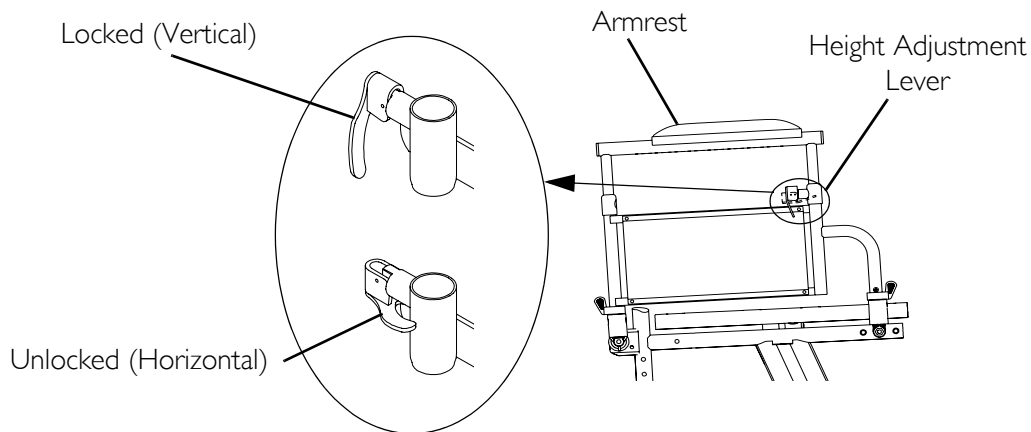

FIGURE 7.1 Adjusting Armrest Height

Using Swing-Back Arms

⚠ WARNING

Make sure the armrest release lever is in the locked position before using the wheelchair.

NOTE: For this procedure, refer to FIGURE 7.2.

1. Unlock the swing-back arms by rotating the armrest release lever toward the outside of the wheelchair.
2. Pull the front of the swing-back arm straight up/out of the arm socket and toward the rear of the wheelchair.
3. To use the swing-back arm, push the swing-back arm toward the front of the wheelchair and then downward into the arm socket.

NOTE: Armrest release lever MUST be in the unlocked position when placing armrest into the arm sockets.

4. Lock the swing-back arms by rotating the armrest release lever toward the inside of the wheelchair.

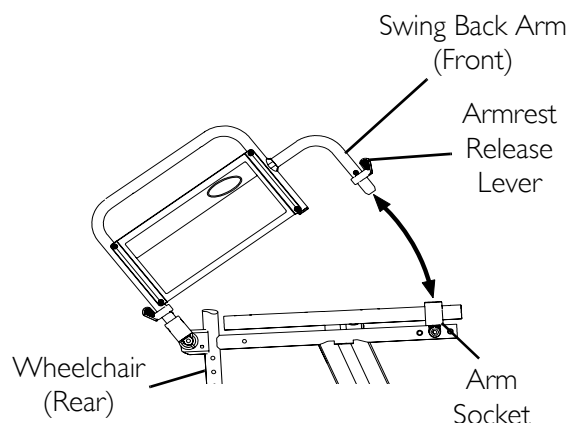

FIGURE 7.2 Using Swing-Back Arms

Replacing Desk/Full Length Armrest Pad and/or Clothing Guards (Fixed Height Arms Only)

NOTE: For this procedure, refer to FIGURE 7.3.

Armrest Pad

1. Remove the two (2) mounting screws that secure the armrest pad to the armrest assembly.
2. Replace armrest pad and securely tighten with the existing mounting screws.
3. Repeat STEPS 1 and 2 for the other armrest.

Clothing Guard

1. Remove the four (4) mounting screws that secure the existing clothing guard to the armrest assembly.
2. Install new clothing guard and securely tighten with the existing mounting screws.
3. Repeat STEPS 1 and 2 for the other clothing guard.

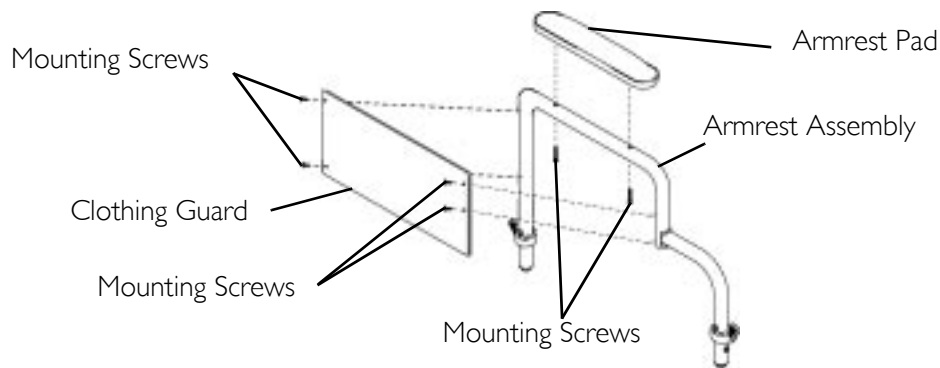

FIGURE 7.3 Replacing Desk/Full Length Armrest Pad and/or Clothing Guards (Fixed Height Arms Only)

Removing/Installing Armrest

⚠ WARNING

Make sure the armrest release lever is in the locked position before using the wheelchair.

NOTE: For this procedure, refer to FIGURE 7.4.

Removing

1. Unlock the armrest by turning the armrest release levers towards the outside of the wheelchair.
2. Lift armrest completely out of arm sockets from the wheelchair.

Installing

NOTE: Armrest release levers MUST be in the unlocked position when placing armrests into the arm sockets.

1. Place armrest into arm sockets located on the side of the wheelchair.
2. Lock the armrest by turning the armrest release levers towards the inside of the wheelchair.

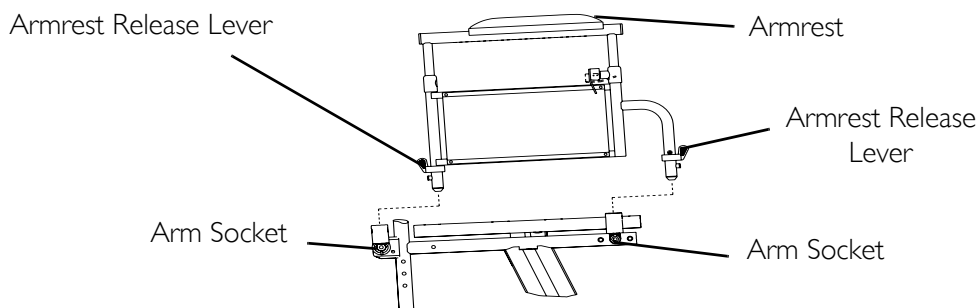

FIGURE 7.4 Removing/Installing Armrest

SECTION 8—BACK

⚠ WARNING

After ANY adjustments, repair or service and BEFORE use, make sure all attaching hardware is tightened securely - otherwise injury or damage may result.

Adjusting the Back Height

NOTE: For this procedure, refer to FIGURE 8.1.

NOTE: Back canes must be adjusted to the same height.

NOTE: Take note of the position and orientation of the back cane mounting hardware before removing. The fold down back canes use two (2) mounting screws to secure the two (2) back canes to the wheelchair frame, the adjustable angle back canes use four (4) mounting screws.

1. Remove the mounting screws and locknuts that secure the two (2) back canes to the back cane mounting tube.
2. Reposition the back canes to the desired height adjustment position as shown in FIGURE 8.1.
3. Reinstall the mounting screws and locknuts that secure the back canes to the back cane mounting tube and securely tighten.

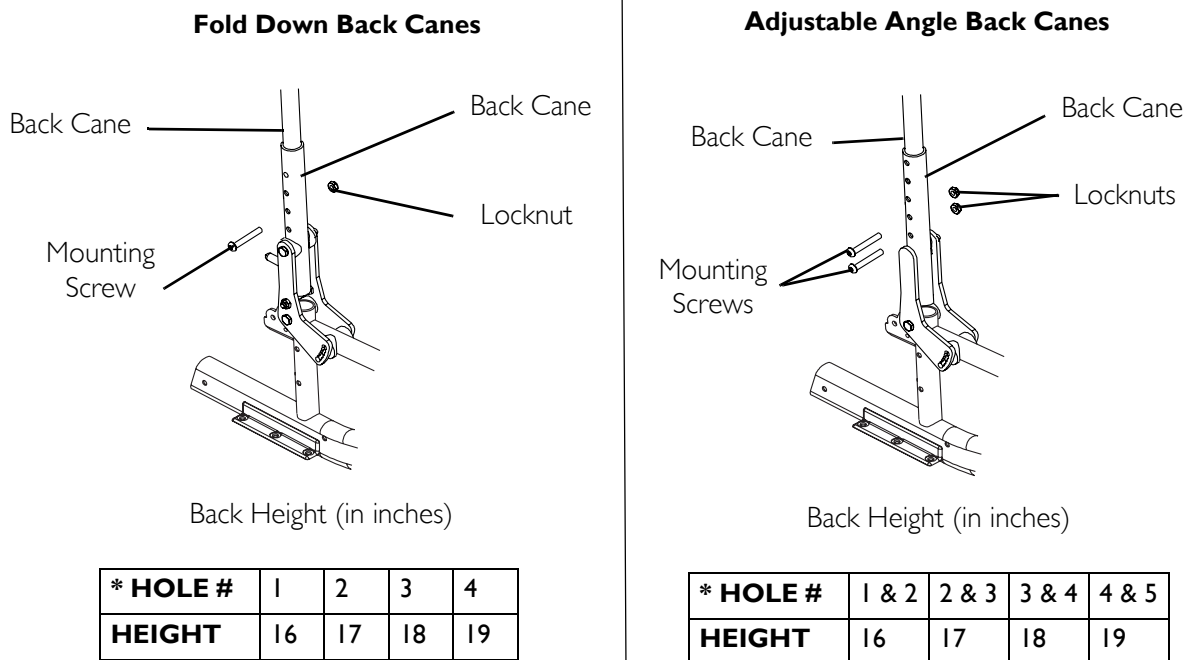

*NOTE: Holes numbered from bottom to top for reference only. There are no numbers on the back canes or wheelchair frame.

FIGURE 8.1 Adjusting the Back Height

Using the Fold Down Back Canes (R5I, 5ILX and R5ILXP Models Only)

⚠ WARNING

The back **MUST** be locked securely in place before using the wheelchair.

NOTE: For this procedure, refer to FIGURE 8.2.

1. Perform one (1) of the following:

- Unfold - Push/pull the back toward rear of wheelchair until it locks in place.
- Fold - Pull up on the back release latches and push the back toward the front of the wheelchair.

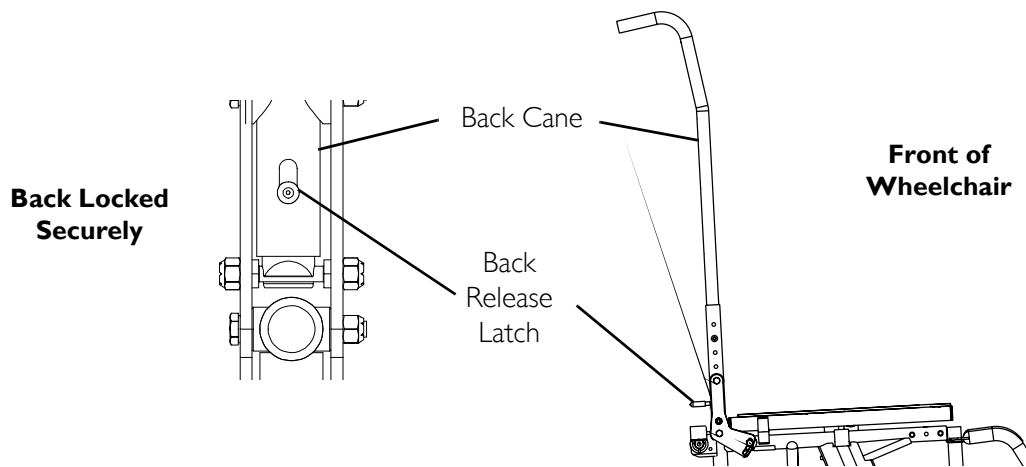

FIGURE 8.2 Using the Fold Down Back Canes (R5I, 5ILX and R5ILXP Models Only)

Changing the Back Angle

NOTE: For this procedure, refer to FIGURE 8.3.

⚠ WARNING

The following procedure must be performed by a qualified technician.

The seat depth and back angle of the wheelchair, as well as the large wheel position directly relate to the stability of the wheelchair. Any change to one (1) or any combination of the three (3) may cause the wheelchair to decrease in stability. Use **EXTREME** caution when using a new seating position for the first time.

1. Loosen, but do not remove the rear hex screw that secures the back angle plate to the wheelchair frame.
2. Remove the front hex screw, washer, and locknut that secure the back angle plate to the wheelchair frame.

3. Position the back angle plate to one (1) of six (6) back angles. Refer to Detail "A" of FIGURE 8.3.
4. Reinstall the front hex screw and washer, securely tighten with locknut. Refer to FIGURE 8.3 for correct hardware orientation.
5. Securely tighten the rear hex screw that secures the back adjustment plate to the wheelchair frame.

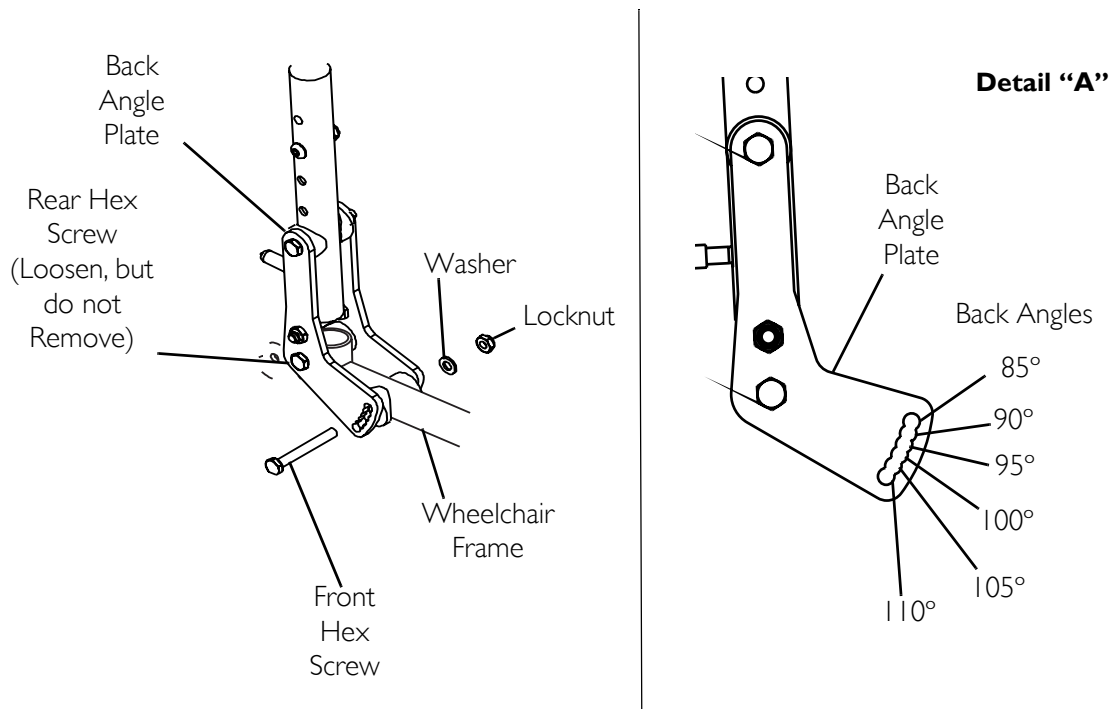

FIGURE 8.3 Changing the Back Angle

SECTION 9—UPHOLSTERY/SEAT POSITIONING STRAP

⚠ WARNING

After ANY adjustments, repair or service and BEFORE use, make sure all attaching hardware is tightened securely - otherwise injury or damage may result.

Replacing Seat Upholstery

NOTE: For this procedure, refer to FIGURE 9.1.

1. Remove the eight (8) phillips screws and washers that secure the existing seat upholstery to the crossbraces.
2. Remove existing seat upholstery from the crossbraces.
3. Line up mounting holes in new seat upholstery with mounting holes in the crossbraces.
4. Securely tighten with existing phillips screws and washers.

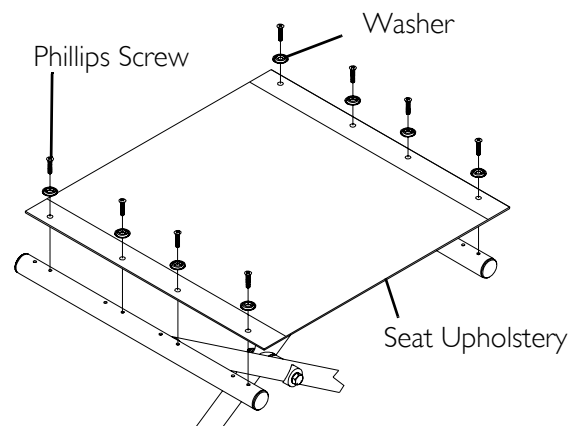

FIGURE 9.1 Replacing Seat Upholstery

NOTE: Clean upholstery with warm DAMP cloth and mild detergent to remove superficial soil.

⚠ WARNING

Laundering or moisture will reduce flame retardation of the upholstery.

Replacing Back Upholstery

NOTE: For this procedure, refer to FIGURE 9.2.

NOTE: Observe the position and orientation of the back cane mounting hardware before removing. The fold down back canes use two (2) mounting screws to secure the two (2) back canes to the wheelchair frame, all other back canes use four (4) mounting screws.

1. Remove the two (2) upholstery mounting screws and washers that secure the existing back upholstery to the back canes.
2. Remove the screws and locknuts that secure the two (2) back canes to the wheelchair frame.
3. Remove the two (2) back canes and the back upholstery from the wheelchair frame.

4. Pull the loose back canes out of the existing back upholstery.
5. Slide the loose back canes into the new back upholstery.
6. Secure the back canes to the wheelchair frame with the mounting screws and locknuts removed in STEP 1.
7. Secure the new back upholstery to the back canes with the two (2) existing upholstery mounting screws and washers.

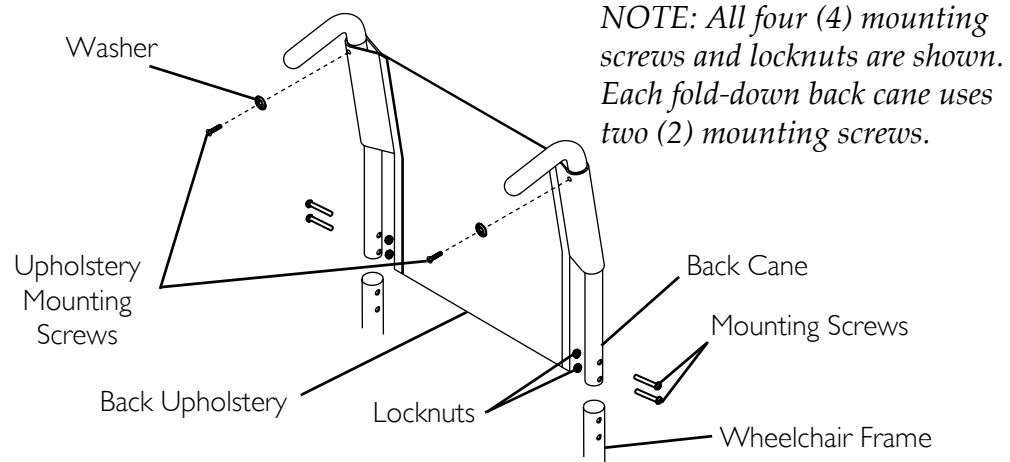

FIGURE 9.2 Replacing Back Upholstery

Replacing Seat Positioning Strap

NOTE: For this procedure, refer to FIGURE 9.3.

1. If necessary, remove the seat cushion from the seat upholstery.
2. Remove the two (2) rear phillips screws and washers that secure the seat upholstery and seat positioning strap to the crossbraces.
3. Remove the two (2) halves of the seat positioning strap from the crossbraces.
4. Position the two (2) new seat positioning strap halves between the seat upholstery and the crossbraces.
5. Reinstall the rear phillips screws and washers that secure the seat upholstery and seat positioning strap to the crossbraces.

NOTE: Washer is positioned on top of seat upholstery.

6. If necessary, reinstall the seat cushion onto the seat upholstery.

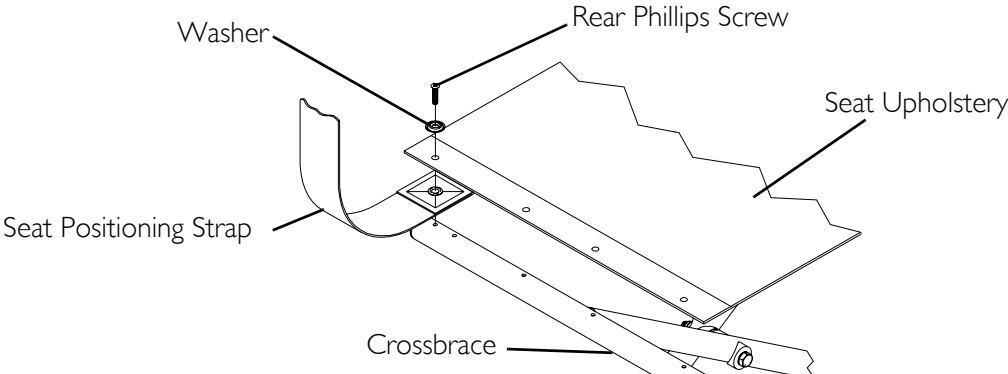

FIGURE 9.3 Replacing Seat Positioning Strap

SECTION 10—JOYSTICK

⚠ WARNING

After ANY adjustments, repair or service and BEFORE use, make sure all attaching hardware is tightened securely - otherwise injury or damage may result.

Preparing the Joystick For Use

NOTE: For this procedure, refer to FIGURE 10.1.

NOTE: The joystick is factory installed on the right side of the wheelchair. To reposition the joystick onto the left side of the wheelchair refer to [Repositioning the Joystick](#) on page 47. The joystick should be repositioned by a qualified technician.

1. Turn the adjustment lock lever to release the joystick mounting tube from the mounting bracket.
2. Slide joystick mounting tube to the desired position.
3. Turn the adjustment lock lever to secure the joystick mounting tube in the mounting bracket.

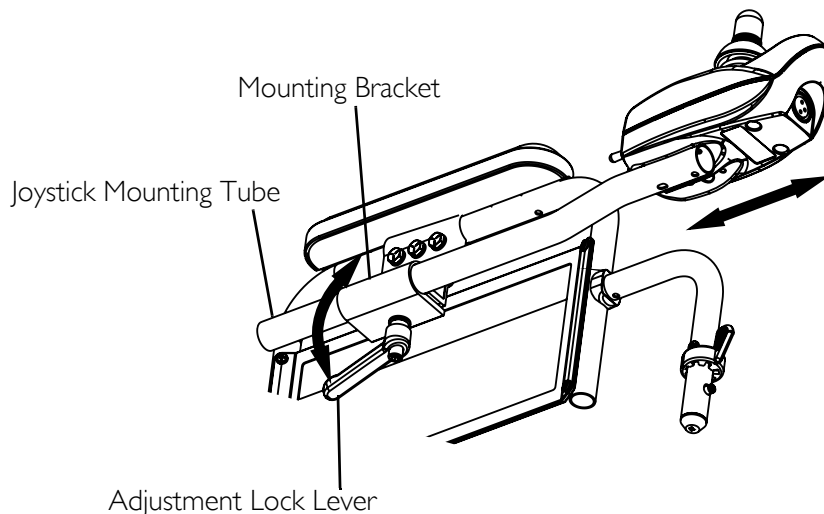

FIGURE 10.1 Preparing the Joystick For Use

Repositioning the Joystick

NOTE: For this procedure, refer to FIGURE 10.2.

1. Turn the adjustment lock lever to release the joystick mounting tube from the mounting bracket.
2. Remove the joystick from the wheelchair.
3. Remove the three (3) hex screws that secure the halves ($\frac{1}{2}$) of the mounting bracket to the arm tube.
4. Reposition mounting bracket on opposite arm tube ensuring the threaded plate of the mounting bracket is on the inside of the arm tube as shown in FIGURE 10.2.
5. Using the three (3) hex mounting screws and washers, secure the halves ($\frac{1}{2}$) of the mounting bracket to the arm tube.
6. Slide the joystick mounting tube through the mounting bracket to the desired position.
7. Turn the adjustment lock lever to secure the joystick mounting tube into the mounting bracket.

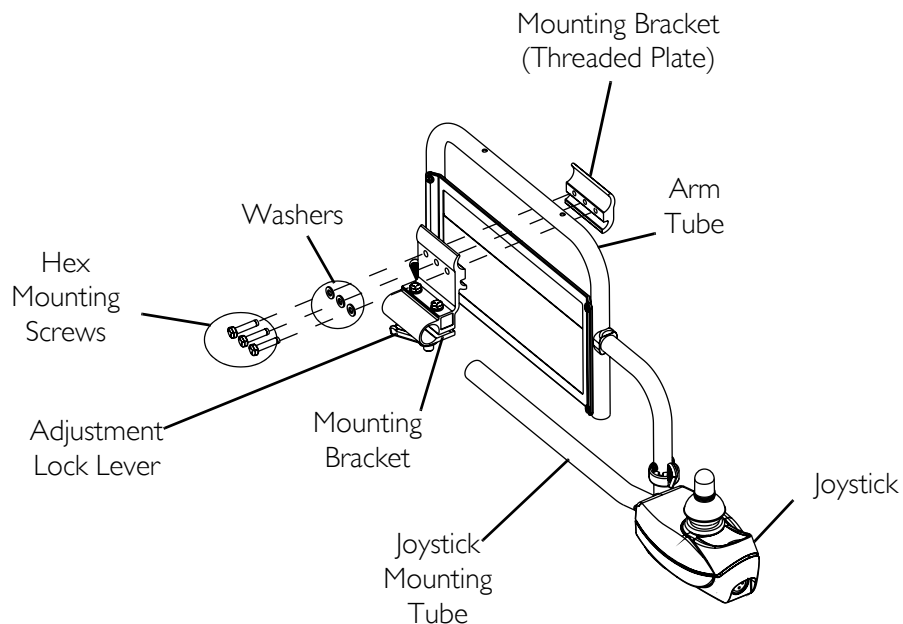

FIGURE 10.2 Repositioning the Joystick

SECTION 11—CASTERS

⚠ WARNING

After **ANY** adjustments, repair or service and **BEFORE** use, make sure that all attaching hardware is tightened securely - otherwise injury or damage may result.

Before performing any maintenance, adjustment or service verify that **ON/OFF** switch on the joystick is in the **OFF** position.

⚠ CAUTION

As with any vehicle, the wheels, casters and tires should be checked periodically for cracks and wear and should be replaced.

Adjusting Forks

NOTE: For this procedure, refer to FIGURE 11.1.

NOTE: It may be necessary to extend the telescoping front rigging support to gain access to the caster headtube hardware. Refer to [Adjusting/Replacing Telescoping Front Rigging Support](#) on page 35.

1. Remove the dust cover from the caster headtube.
2. To properly tighten caster journal system and guard against flutter, perform the following check:
 - A. Remove battery boxes from wheelchair. Refer to [Installing/Removing the Battery Boxes](#) on page 51.
 - B. Tip back the wheelchair to floor.
 - C. Pivot both forks and casters to top of their arc simultaneously.
 - D. Let casters drop to bottom of arc (wheels should swing once to one-side, then immediately rest in a straight downward position).
 - E. Adjust locknuts according to freedom of caster swing.
3. Test wheelchair for maneuverability.
4. Readjust locknuts, if necessary, and repeat STEPS 1-3 until correct.
5. Snap dust cover into the caster headtube.

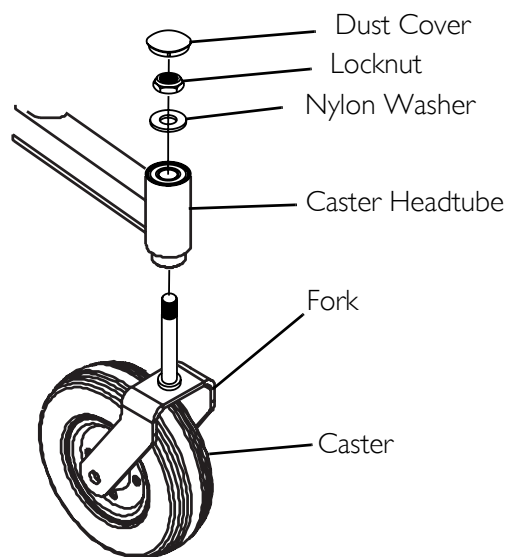

FIGURE 11.1 Adjusting Forks

SECTION 12—BATTERIES

Warnings for Handling and Replacing Batteries

⚠ WARNINGS

After ANY adjustments, repair or service and BEFORE use, make sure that all attaching hardware is tightened securely - otherwise injury or damage may result.

Make sure power to the wheelchair is off before performing this section.

The use of rubber gloves and chemical goggles or face shields is recommended when working with batteries.

Invacare strongly recommends that battery installation and battery replacement ALWAYS be done by a qualified technician.

ALWAYS use a battery lifting strap when lifting a battery. It is the most convenient method and assures that the battery acid will not spill. It also helps to prolong the life of the battery.

DO NOT tip the batteries. Keep the batteries in an upright position.

NEVER allow any of your tools and/or battery cable(s) to contact BOTH battery posts at the same time. An electrical short may occur and serious personal injury or damage may occur.

The POSITIVE (+) RED battery cable must connect to the POSITIVE (+) battery terminal, otherwise serious damage will occur to the electrical system.

NOTE: If there is battery acid in the bottom of the battery tray or on the sides of the battery(ies), apply baking soda to these areas to neutralize the battery acid. Before reinstalling the existing or new battery(ies), clean the baking soda from the battery tray or battery(ies) being sure to avoid contact with skin and eyes. Determine source of contamination. Never install/reinstall a battery with a cracked or otherwise damaged case.

Using the Proper Batteries

NOTE: For this procedure, refer to FIGURE 12.1.

1. Place battery on ground/flat surface.
2. Visually draw a horizontal and vertical centerline through the middle of battery (FIGURE 12.1).
3. Position the battery so that the terminals are above the horizontal centerline.
4. Visually inspect the battery to ensure the correct position of the POSITIVE and NEGATIVE terminals (FIGURE 12.1).

⚠ WARNING

Batteries with terminal configuration as shown in **FIGURE 12.1** must be used. Batteries that have the reverse terminal configuration **MUST NOT** be used - otherwise injury and damage may occur.

Terminals **MUST** have a cross hole in them as shown below.

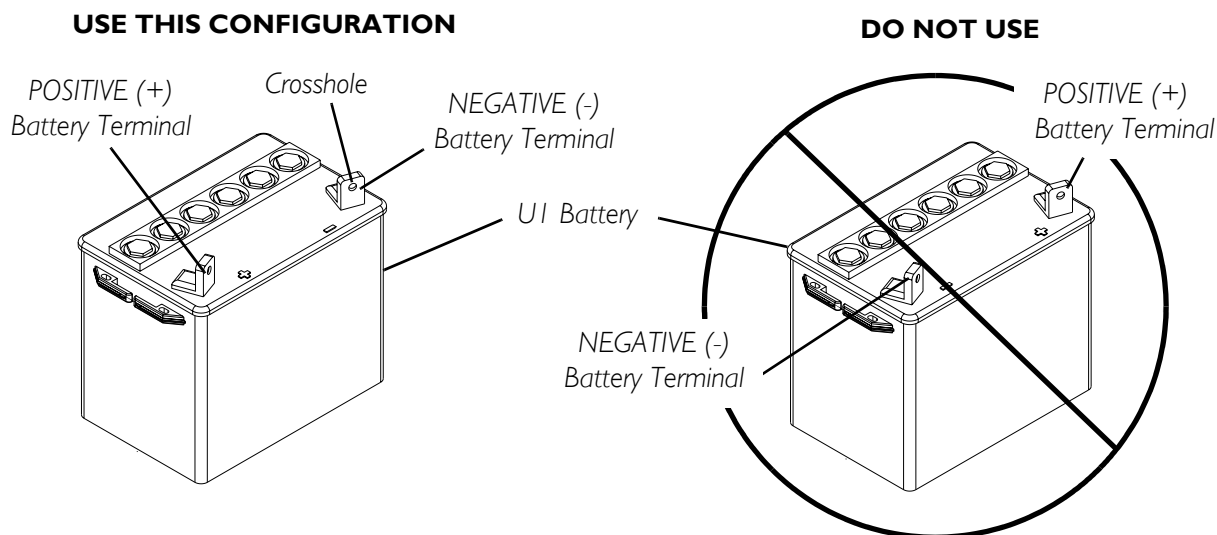

FIGURE 12.1 Using the Proper Batteries

Recommended Battery Types

⚠ WARNING

The warranty and performance specifications contained in this manual are based on the use of deep cycle gel cell batteries. Invacare strongly recommends their use as the power source for this unit.

⚠ CAUTION

Failure to use the correct battery size and/or voltage may cause damage to your wheelchair and give you unsatisfactory performance.

CHAIRSEATWIDTH	QTY	VOLTS	BATTERY SIZE	REMARKS
14 inches	2	12	U1	Deep Cycle
16, 18, 20 inches	2	12	22NF or U1	Deep Cycle

1. Remove the battery boxes and tray from the wheelchair. Refer to Installing/Removing the Battery Boxes on page 51 of the manual.

2. Remove the existing batteries from the battery boxes. Refer to Installing/Removing the Batteries Into/From the Battery Boxes on page 53.
3. Clean the new battery terminals. Refer to Cleaning Battery Terminals on page 62.
4. Install the new batteries into the battery boxes. Refer to Installing/Removing the Batteries Into/From the Battery Boxes on page 53 of this manual.
5. Install the battery boxes onto the wheelchair. Refer to Installing/Removing the Battery Boxes on page 51 of the manual.

Installing/Removing the Battery Boxes

⚠ WARNING

NEVER unplug the battery cables by pulling on the wires. Unplug the battery cables by pulling on the connector ONLY. Otherwise injury or damage may result.

NOTE: For this procedure, refer to FIGURE 12.2.

NOTE: To remove the battery boxes from the wheelchair, reverse the following procedure.

1. Verify that the on/off switch on the joystick is in the off position.
 2. Place the front battery box onto the battery tray and connect controller connector to the front battery box.
 3. Slide front battery box toward the front of the wheelchair.
 4. Place rear battery box onto the battery tray and connect the rear battery box to the front battery box.
 5. Connect the front battery box to the controller.
-

⚠ WARNING

The battery box retaining strap MUST be fastened securely and adjusted properly to hold battery boxes in place before using the wheelchair.

6. Connect the battery box retaining strap clip together and adjust if necessary.

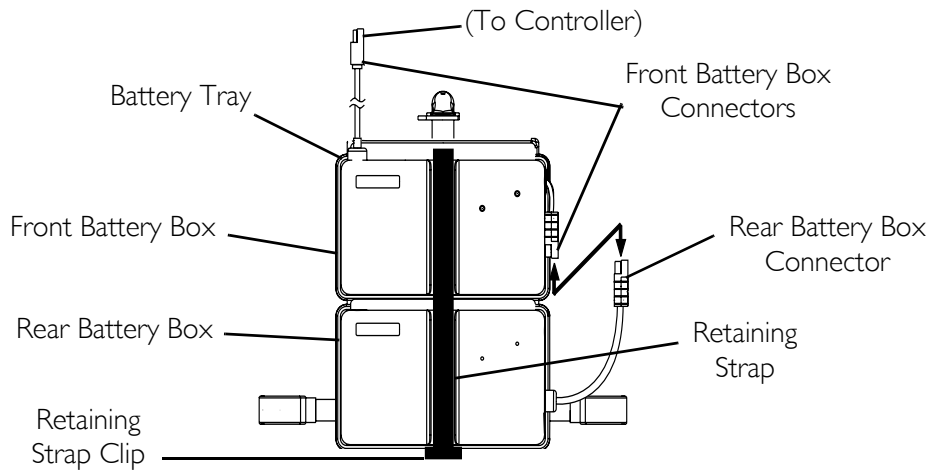
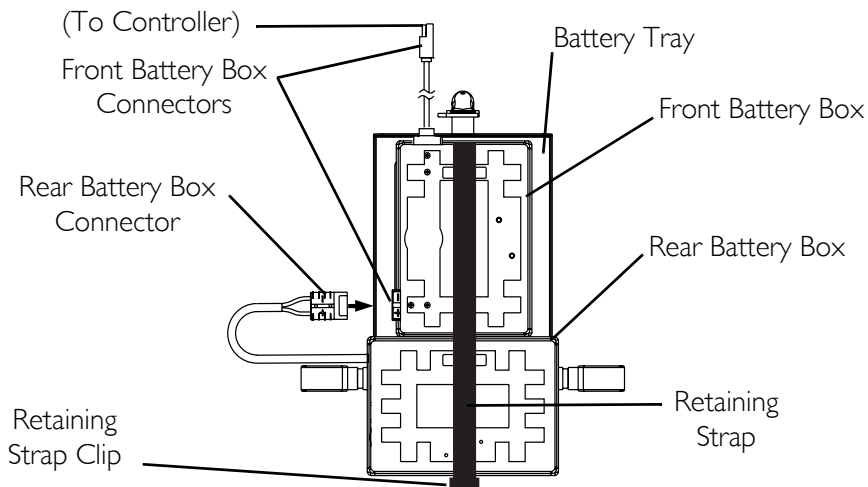
Detail “A” 16, 18, and 20-Inch Wide Wheelchair**Detail “B” 14-Inch Wide Wheelchair****FIGURE 12.2** Installing/Removing the Battery Boxes**Installing/Removing the Battery Tray**

NOTE: For these procedures, refer to FIGURE 12.3.

NOTE: To remove the battery tray from the wheelchair, reverse the following procedure.

1. Attach the key slot bracket located at the front of the battery tray over the crossbrace bolt bushing under the seat upholstery of the wheelchair.
2. Attach the hanger brackets to the wheelchair frame.

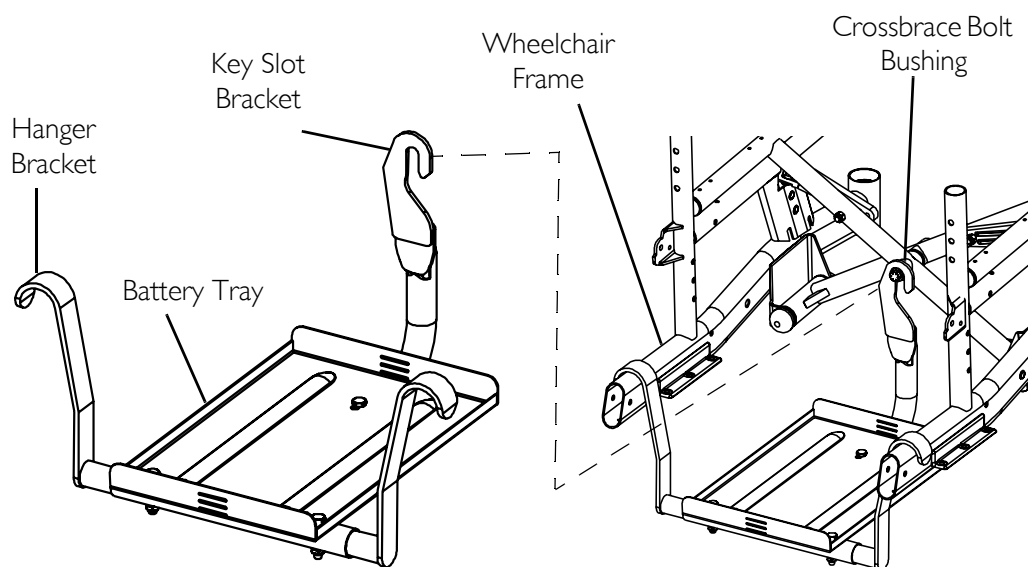

FIGURE 12.3 Installing/Removing the Battery Tray

Installing/Removing the Batteries Into/From the Battery Boxes

⚠ WARNING

Make sure power to the wheelchair is OFF before performing this procedure.

The use of rubber gloves and chemical goggles or face shields is recommended when working with batteries.

Invacare strongly recommends that battery installation and battery replacement ALWAYS be done by a qualified technician.

After ANY adjustments, repair or service and BEFORE use, make sure all attaching hardware is tightened securely - otherwise injury or damage may result.

ALWAYS use a battery lifting strap when lifting a battery. It is the most convenient method and assures that the battery acid will not spill. It also helps to prolong the life of the battery.

DO NOT tip the batteries. Keep the batteries in an upright position.

NOTE: For this procedure, refer to FIGURE 12.4.

NOTE: For changing or removing/installing the battery boxes, refer to Installing/Removing the Battery Boxes on page 51.

NOTE: To remove a battery from the battery box, reverse the following procedure.

NOTE: Have the following tools available:

TOOL	QTY	COMMENTS
Battery lifting strap	1	Refer to Note
1/2-inch (6 pt) box wrench	1	Not supplied
7/16-inch (6pt) Box Wrench	1	Not supplied
3/8-inch (6pt) Box Wrench	1	Not supplied
Diagonal cutters	1	Not supplied

NOTE: The battery lifting strap supplied is for Group 22 batteries ONLY. Refer to the battery manufacturer for the proper lifting strap and/or battery tools for U1 battery removal/installation.

NOTE: If there is battery acid in the bottom or on the sides of the battery box(es) or battery(ies), apply baking soda to these areas to neutralize the battery acid. Before reinstalling the new or existing battery(ies), clean the baking soda from the battery box(es) or battery(ies).

NOTE: When securing battery lifting strap to battery, observe polarity markings located on the ends of the battery lifting strap, (+) side to POSITIVE (+) battery terminal/post and (-) side to NEGATIVE (-) battery terminal/post.

1. If necessary, remove the battery boxes from the wheelchair. Refer to Installing/Removing the Battery Boxes on page 51.
2. Secure the battery lifting strap to battery terminal(s)/post(s).

△ CAUTION

Some battery manufacturers mold a carrying strap and/or hold down flanges directly into the battery case. Batteries which interfere with the battery box cannot be used for these applications. Attempting to “wedge” a battery into a battery box may damage the box and/or the battery.

3. Place batteries into battery box bottom.

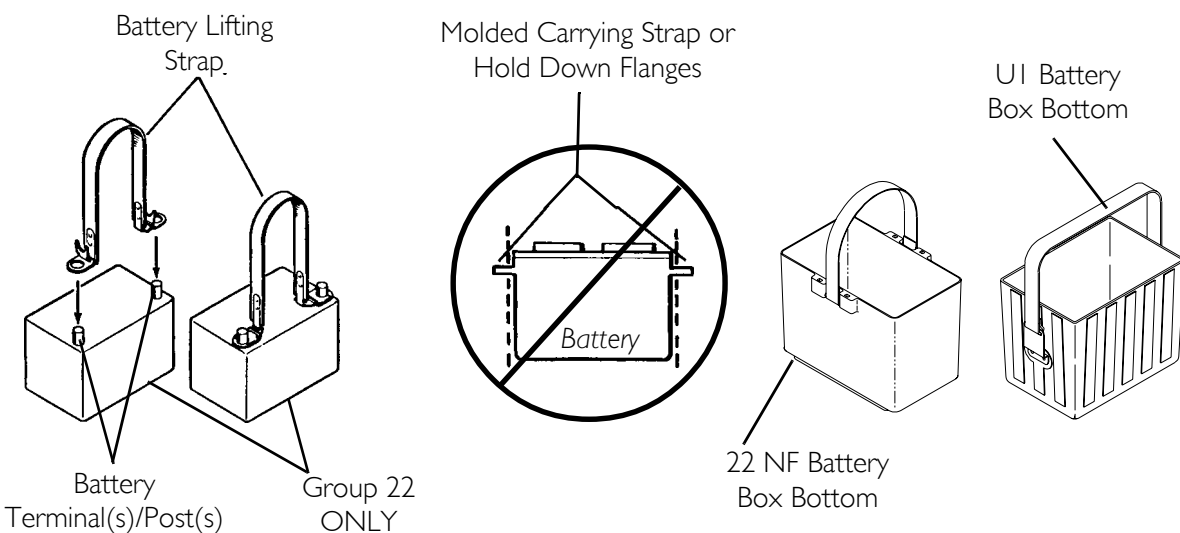

FIGURE 12.4 Installing/Removing the Batteries Into/From the Battery Boxes

Connecting Battery Cables

⚠ WARNING

The use of rubber gloves and chemical goggles or face shields is recommended when working with batteries.

NEVER allow any of your tools and/or battery cable(s) to contact **BOTH** battery terminal(s)/post(s) at the same time. An electrical short may occur and serious personal injury or damage may occur.

Perform one (1) of the following methods for connecting the battery cable(s):

- Dual U1 Batteries - Use direct mount method. Refer to FIGURE 12.5 and FIGURE 12.6.
- Dual Group 22NF Batteries with Mounting Holes in the Terminal(s)/Post(s) - Use direct mount method. Refer to FIGURE 12.5 and FIGURE 12.6.
- Dual Group 22NF Batteries without Mounting Holes in the Terminal(s)/Post(s) - Use battery clamp method. Refer to FIGURE 12.7, FIGURE 12.8 and FIGURE 12.9.

Direct Mount Method

NOTE: For this procedure, refer to FIGURE 12.5 and FIGURE 12.6.

1. Install battery terminal cap(s) onto battery cable(s):
 - A. Dual U1 Batteries -
 - i. ORANGE battery terminal cap onto RED battery cable.
 - ii. GREY battery terminal cap onto BLACK battery cable.
 - B. Dual Group 22NF Batteries -
 - i. RED battery terminal cap onto RED battery cable.
 - ii. BLACK battery terminal cap onto BLACK battery cable.

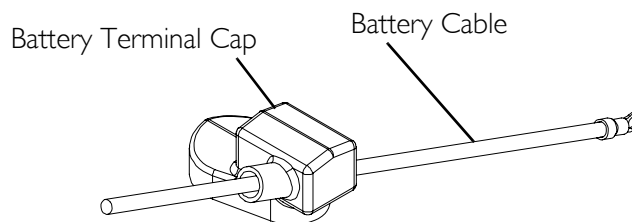

NOTE: Only one battery cable and terminal cap shown for clarity. Both caps install in the same manner.

FIGURE 12.5 Installing Battery Terminal Cap

△ CAUTION

When connecting the battery cables to the battery(ies), the battery cable(s) MUST be connected to the battery terminal(s)/post(s) as shown in Detail “A” or Detail “B” of FIGURE 12.6 (depending on battery type), otherwise damage to the battery cable may result when installing battery terminal caps.

2. Connect battery cable(s) to battery(ies) terminal(s)/post(s) as shown in Detail “A” or Detail “B” of FIGURE 12.6, depending on battery type:
 - A. NEGATIVE (-) BLACK battery cable to NEGATIVE (-) battery terminal/post.
 - B. POSITIVE (+) RED battery cable to POSITIVE (+) battery terminal/post.
3. Secure the battery cable(s)/ring terminal(s) to the battery terminal(s)/post(s), BLACK to NEGATIVE (-) and RED to POSITIVE (+), with the provided 1/4-20 x 7/8-inch hex flange screw and hex flange locknut as shown in Detail “A” or Detail “B” of FIGURE 12.6, depending on battery type. Securely tighten.
4. Verify all battery cable(s)/ring terminal(s) are correctly installed and securely tightened.
5. Slide terminal cap(s) down battery cable(s) and onto battery clamps (FIGURE 12.6).
6. Using the 11½-inch long tie-wrap, secure each terminal cap in place (Detail “C” of FIGURE 12.6).

NOTE: It will be necessary to trim excess tie-wrap in order to install the battery box top(s).

7. Install the battery box top(s).
8. Install the battery box(es) into the wheelchair. Refer to Installing/Removing the Battery Boxes on page 51.

NOTE: New battery(ies) MUST be fully charged BEFORE using, otherwise the life of the battery(ies) will be reduced.

9. If necessary, charge the battery(ies). Refer to Charging Batteries on page 63.

Detail “A” - Dual UI Batteries

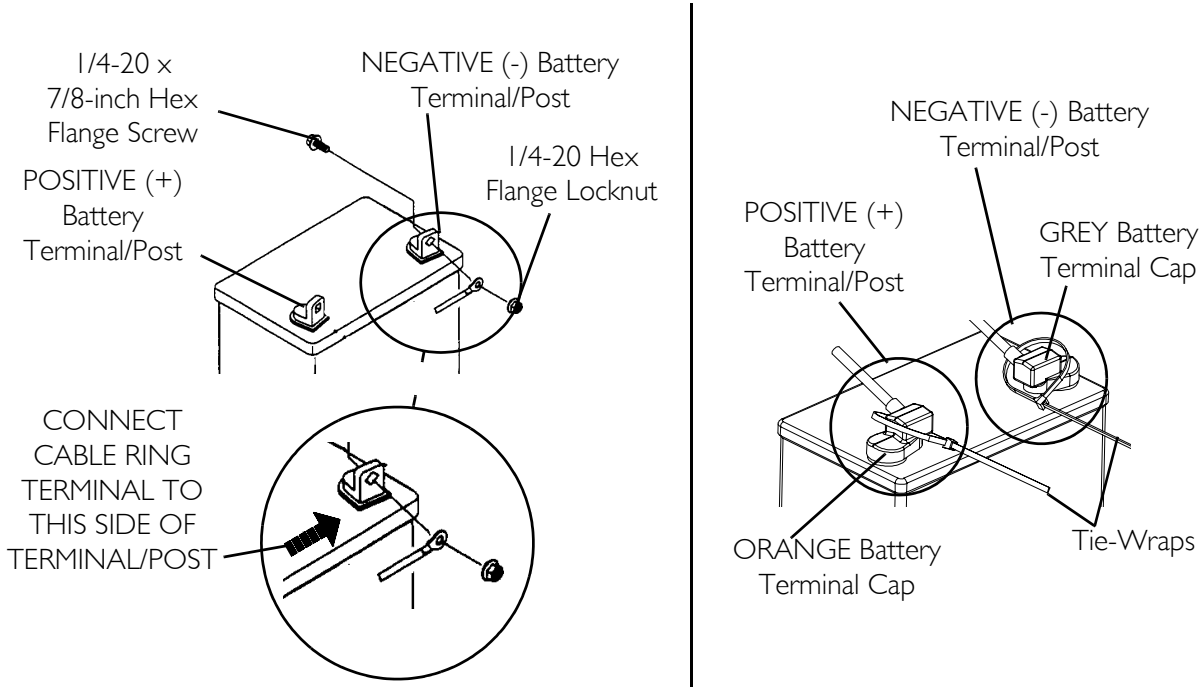

Detail “B” - Dual Group 22 NF Batteries

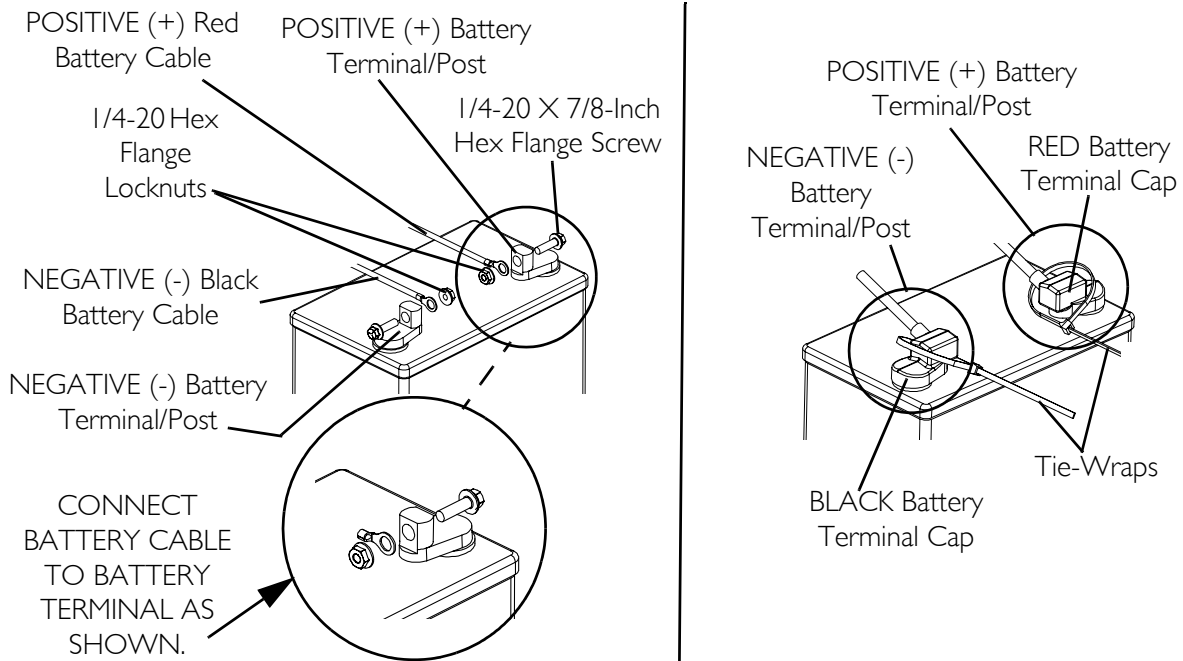

FIGURE 12.6 Connecting Battery Cables - Direct Mount Method

Battery Clamp Method

⚠ WARNING

The battery clamp of the **POSITIVE (+)** battery terminal/post **MUST** be mounted in the position shown in **FIGURE 12.7**, otherwise the battery box top cannot be installed properly.

NOTE: For this procedure, refer to FIGURE 12.7, FIGURE 12.8 and FIGURE 12.9.

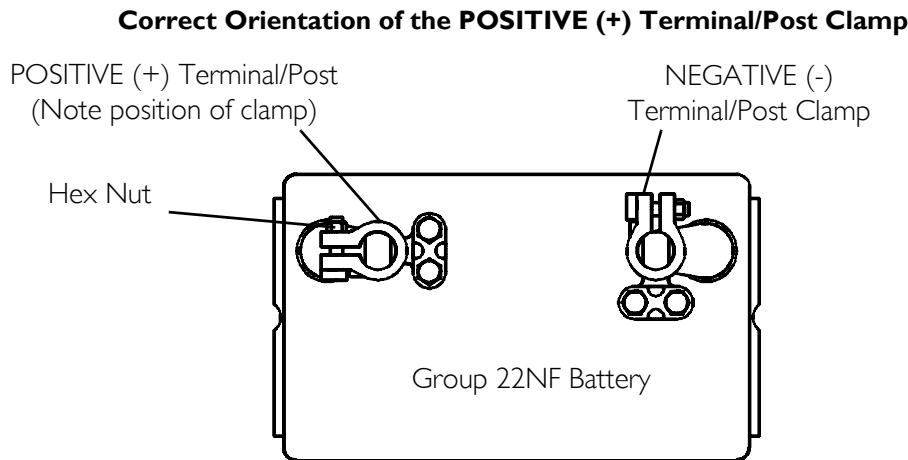

FIGURE 12.7 Connecting Battery Cables - Battery Clamp Method

1. Perform one (1) of the following:
 - If the battery clamp of the POSITIVE (+) battery terminal/post is NOT mounted in the orientation shown in FIGURE 12.7, perform the following:
 - i. Loosen the hex nut that secures the battery clamp to the POSITIVE (+) battery terminal/post.

⚠ CAUTION

When tightening the clamps, always use a box wrench. Pliers will “round off” the nuts. NEVER wiggle the battery terminal(s)/post(s) when tightening. The battery may become damaged.

- ii. Remove the battery clamp from the POSITIVE (+) battery terminal/post.
 - iii. Reposition the battery clamp on the POSITIVE (+) battery terminal/post as shown in FIGURE 12.7.
 - iv. Securely tighten the hex nut that secures the battery clamp to the positive (+) battery terminal/post.
- If the battery clamp on the POSITIVE (+) battery terminal/post is positioned as shown in FIGURE 12.7, proceed to STEP 2.

2. Install battery clamp covers onto battery cables (FIGURE 12.8) -
 - A. RED battery clamp cover onto RED battery cable.
 - B. BLACK battery clamp cover onto BLACK battery cable.

NOTE: Only one (1) battery cable and battery clamp cover are shown for clarity. Both battery clamp covers install in the same manner.

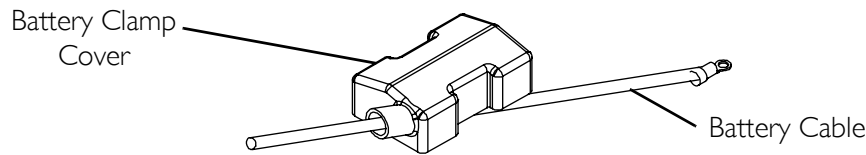

FIGURE 12.8 Installing Battery Clamp Cover

△ CAUTION

When connecting the battery cable/ring terminal(s) to the battery(ies) clamp(s), the battery cable(s) MUST be connected in the position shown in Detail “A” of FIGURE 12.9. Otherwise, damage can occur to the battery cable and/or battery clamp covers.

3. Connect battery cable(s) to battery(ies) terminal(s)/post(s) as shown in Detail “A” of FIGURE 12.9:
 - A. NEGATIVE (-) BLACK battery cable/ring terminal between the mounting plate and battery clamp of NEGATIVE (-) battery terminal/post.
 - B. POSITIVE (+) RED battery cable/ring terminal between the mounting plate and battery clamp of POSITIVE (+) battery terminal/post.
4. Secure the battery cable(s)/ring terminal(s) to the battery clamp(s), BLACK to NEGATIVE (-) and RED to POSITIVE (+), with existing hex screws as shown in Detail “A” of FIGURE 12.9. Securely tighten.
5. Verify battery cable ring terminal(s) are correctly installed and securely tightened.
6. Slide battery clamp covers down battery cables and onto battery terminals as shown in Detail “B” of FIGURE 12.9.
7. Using 11½-inch long tie-wraps, secure each terminal cap in place as shown in Detail “B” of FIGURE 12.9.

NOTE: It will be necessary to trim excess tie-wrap in order to install the battery box top(s).

8. Install the battery box top(s).
9. Install the battery box(es) into the wheelchair. Refer to Installing/Removing the Battery Boxes on page 51.

NOTE: New battery(ies) MUST be fully charged BEFORE using, otherwise the life of the battery(ies) will be reduced.

10. If necessary, charge the battery(ies). Refer to Charging Batteries on page 63.

Exploded View

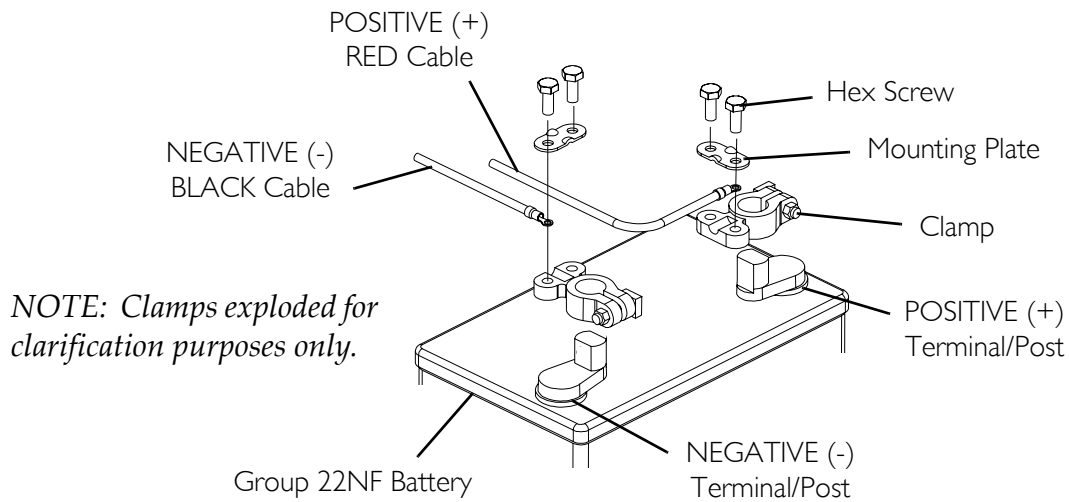

Top View

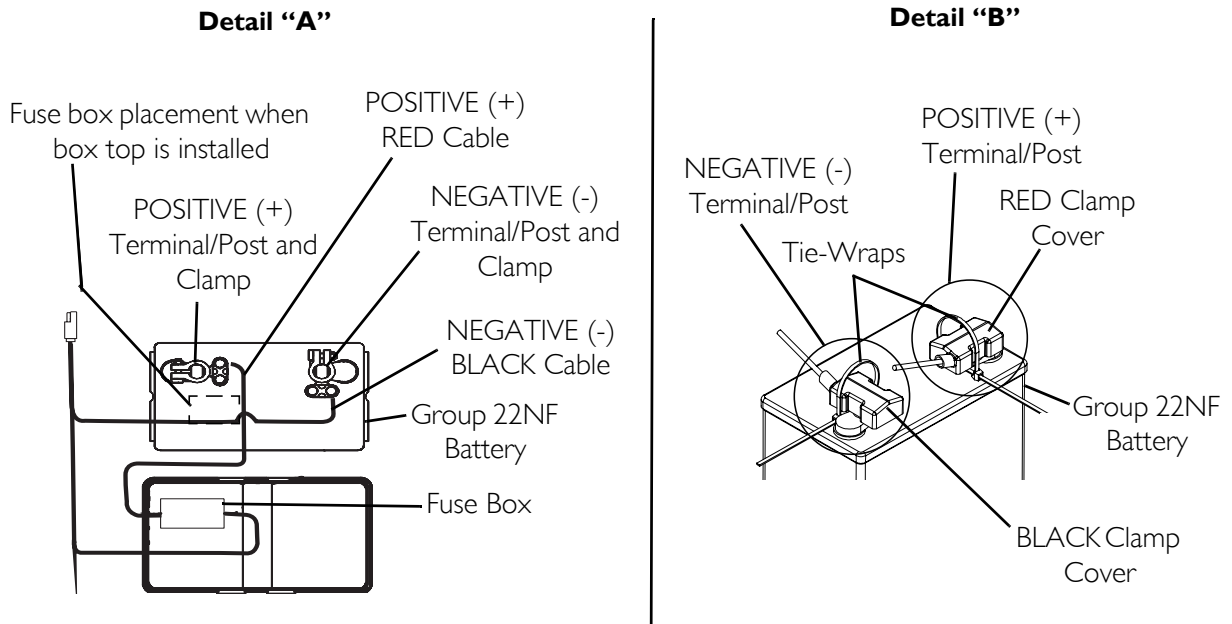

FIGURE 12.9 Connecting Battery Cables -Battery Clamp Method

Replacing the Battery Box Retaining Strap

NOTE: For this procedure, refer to FIGURE 12.10.

⚠ WARNING

The battery box retaining strap MUST be fastened securely and adjusted properly to hold battery boxes in place before using the wheelchair.

1. Remove the battery boxes from the wheelchair. Refer to Installing/Removing the Battery Boxes on page 51.
 2. Remove the battery tray from the wheelchair. Refer to Installing/Removing the Battery Tray on page 52.
-

⚠ WARNING

The retaining strap MUST be fed through the adjustable end of the battery box retaining strap buckle as shown in FIGURE 12.10.

NOTE: Observe the position and orientation of the battery box retaining strap as it passes through the slots of the battery tray and the adjustable end of the battery box retaining strap buckle.

3. Feed the existing battery box retaining strap through the adjustable end of the battery box retaining strap buckle.
4. Feed the existing battery box retaining strap through the slots in the battery box tray.
5. Install the NEW battery box retaining strap by reversing STEPS 3 and 4 as shown in FIGURE 12.10.
6. Reinstall the battery tray from the wheelchair. Refer to Installing/Removing the Battery Tray on page 52.
7. Reinstall the battery boxes from the wheelchair. Refer to Installing/Removing the Battery Boxes on page 51.

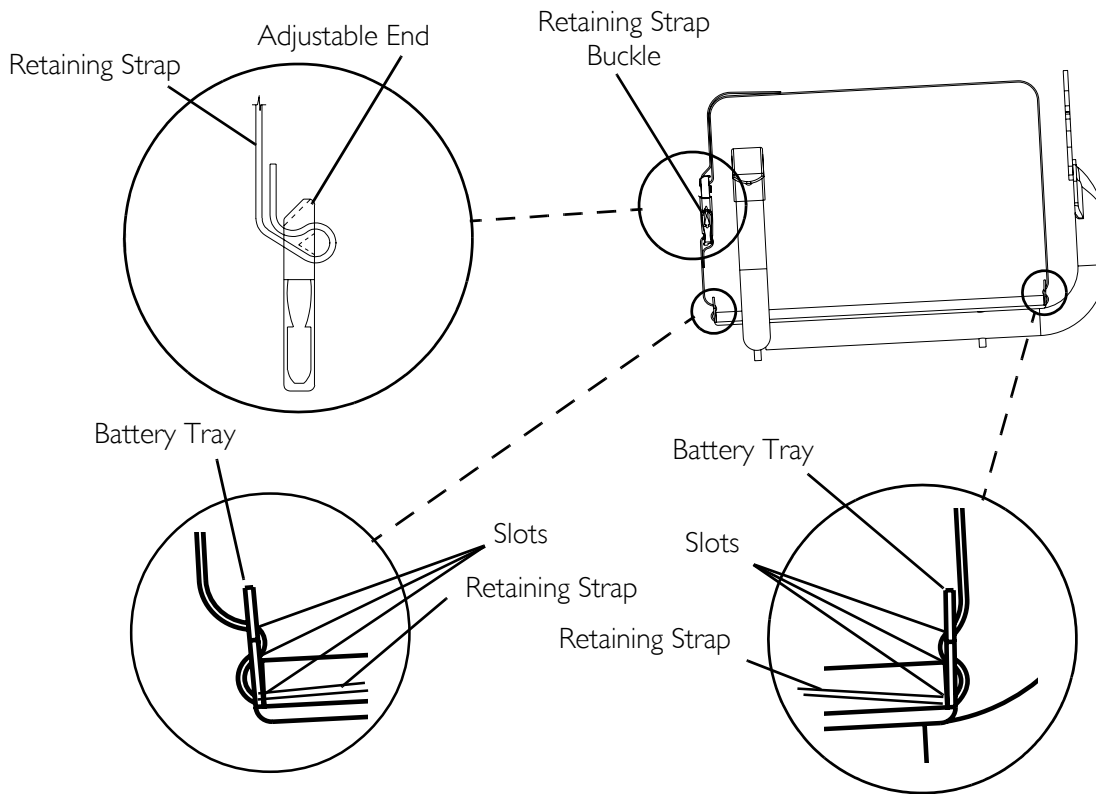

FIGURE 12.10 Replacing the Battery Box Retaining Strap

Cleaning Battery Terminals

⚠ WARNING

Most batteries are not sold with instructions. However, warnings are frequently displayed on the cell caps. Read them carefully.

DO NOT allow the liquid in the battery to come in contact with skin, clothes or other possessions. It is a form of acid and harmful or damaging burns may result. Should the liquid touch your skin, wash the area immediately and thoroughly with cool water. In serious cases or if eye contact is made, seek medical attention immediately.

NEVER smoke or strike a match near batteries. If the caps of the battery cells are removed, **NEVER** look directly into them while charging batteries.

1. Examine battery clamps and terminals for corrosion.
2. Verify that the plastic caps are in place over the battery cell holes.
3. Clean the terminals and inside the battery clamps by using a battery cleaning tool, wire brush, or medium grade sand paper.

NOTE: When done, these areas should be shiny, not dull.

4. Carefully dust off all metal particles.

Charging Batteries

When To Charge Batteries

NOTE: For this procedure, refer to FIGURE 12.11.

Recharge the batteries frequently. Do not wait until the battery charge is low to recharge. A battery's life is extended if the charge level is maintained well above a low condition.

Information Gauge - Located on the joystick housing. The information gauge is the primary source of user feedback.

The true state-of-battery-charge notification is as follows:

Any GREEN LED lit - Batteries are at full or well charged.

Only AMBER and RED LEDs lit - Batteries are moderately charged. Recharge before undertaking a long trip.

Only RED LED lit - Battery charge is low. Recharge as soon as possible.

NOTE: Accurate readings are displayed when in neutral.

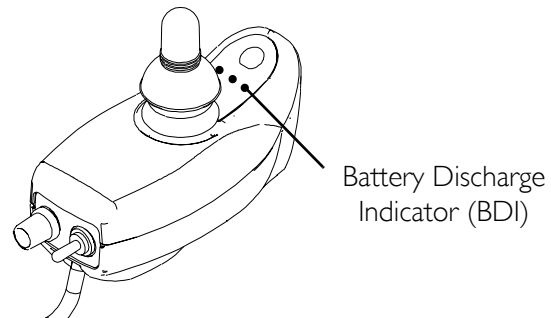

FIGURE 12.11 When To Charge Batteries

⚠ WARNINGS

Never attempt to recharge the batteries by attaching cables directly to the battery terminals or clamps. Use the recharging plug located on either the rear of the wheelchair frame or on the front of the joystick.

DO NOT attempt to recharge the batteries and operate the power wheelchair at the same time.

DO NOT attempt to recharge the batteries when the wheelchair has been exposed to ANY type of moisture.

DO NOT attempt to recharge the batteries when the wheelchair is outside.

DO NOT sit in the wheelchair while recharging the batteries.

During use and charging, unsealed batteries will vent hydrogen gas which is explosive in the right concentration with air.

⚠ CAUTION

New batteries MUST be fully charged prior to initial use of the wheelchair.

Always charge new batteries before initial use or battery life will be reduced.

NOTE: As a general rule, batteries should be recharged daily to assure the longest possible life and minimize the required charging time. Plan to recharge the batteries when it is anticipated the wheelchair will not be used for a long period of time.

The range per battery charge using recommended batteries should be approximately 5 to 9 hours of typical operation. Extensive use on inclines may substantially reduce per charge mileage.

Description and Use of Battery Chargers

The charger automatically reduces the charge from an initially high rate to a zero reading at a fully charged condition. If left unattended, the charger should automatically shut-off when full charge is obtained.

Some basic concepts which will help you understand this automatic process are:

The amount of electrical current drawn within a given time to charge a battery is called “charge rate”. If, due to usage, the charge stored in the battery is low, the charge rate is high, as indicated by the green light on the charger. Initially, the green light will stay illuminated for a short period of time followed by a longer period of off time. As a charge builds up, the charge rate is reduced, and the green light will stay illuminated for a longer period of time followed by a shorter off time.

NOTE: If performing the charging procedures independently, READ and CAREFULLY follow the individual instructions for each charger (supplied or purchased).

NOTE: If charging instructions are not supplied, consult a qualified service technician for proper procedures. Required items:

TOOL	QUANTITY	COMMENTS
Battery Charger	1	Supplied
Extension Cord*	1	Not Supplied

NOTE: 3-prong plug, 15 ampere current rating; industrial type

Connecting the Battery Charger

NOTE: For this procedure, refer to FIGURE 12.12.

1. Attach the battery charger connector to the charger port on the front of the joystick.
2. Plug the charger’s AC power cord, or extension, into the grounded 120 VAC wall outlet.
3. Wait until charging is complete.

NOTE: If the batteries need to be charged more often or take longer to charge than normal, they may need to be replaced. Contact an Invacare dealer for service.

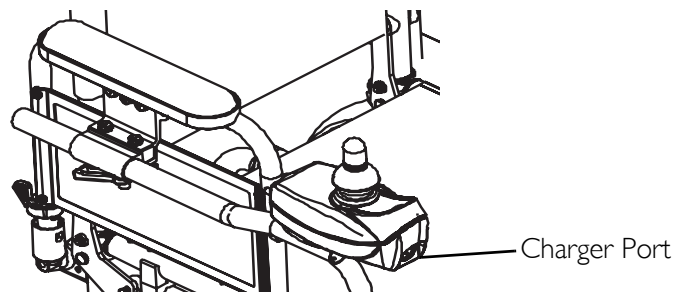

FIGURE 12.12 Charging Batteries

SECTION 13—CLUTCH/MOTOR LOCK

⚠ WARNING

After ANY adjustments, repair or service and BEFORE use, make sure all attaching hardware is tightened securely - otherwise injury or damage may result.

Engaging/Disengaging the Clutches

⚠ WARNING

DO NOT engage or disengage the clutches until the power is off.

NOTE: For this procedure, refer to FIGURE 13.1.

The clutch engagement/disengagement allows free-wheeling or joystick controlled operation. Free-wheeling allows an attendant to maneuver the wheelchair without power. To engage/disengage the clutches:

1. Locate the clutch handles on motors as shown in FIGURE 13.1.

⚠ CAUTION

If clutch handles are forced to engage in the wrong direction as shown in FIGURE 13.1, the motors will be damaged and will need to be replaced.

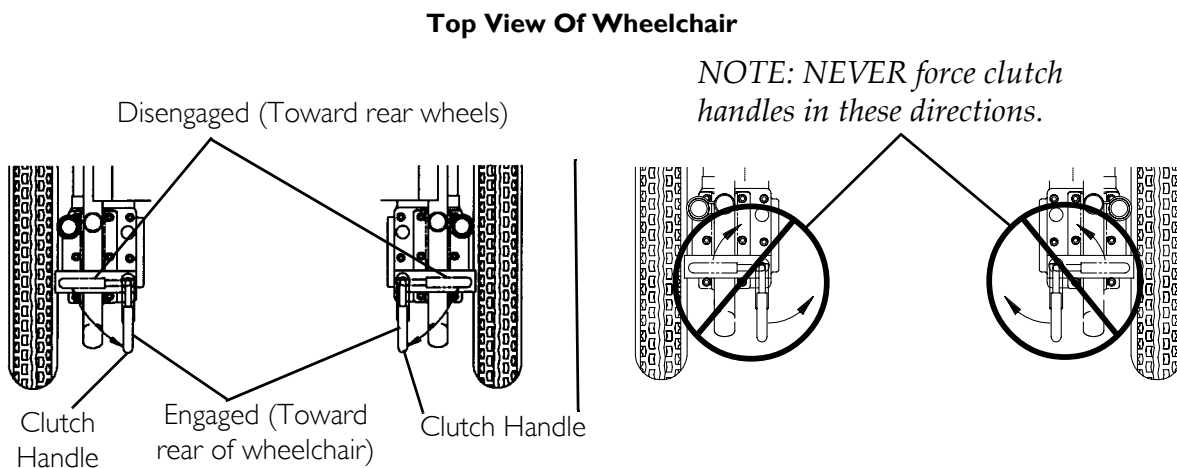

FIGURE 13.1 Engaging/Disengaging the Clutches

2. Perform one (1) of the following -

- To Engage: turn the clutch handles until they are pointing toward the rear of the wheelchair. NEVER try to turn the clutch handles toward the front of the wheelchair.

- To Disengage: turn the clutch handles until they are pointing toward the rear wheels. NEVER try to turn the clutch handles toward the inside of the wheelchair.

Disengaging/Engaging the Motor Lock Levers - R5 ILXP Only

⚠ WARNING

DO NOT engage or disengage motor locks until the power is in the off position.

NOTE: For this procedure, refer to FIGURE 13.2.

NOTE: Motor lock disengagement/engagement allows free-wheeling or joystick controlled operation. Free-wheeling allows an assistant to maneuver the wheelchair without power.

Four Pole Motors

1. Perform one (1) of the following:
 - Disengage (push) - Push motor lock levers downward.
 - Engage (drive) - Pull motor lock levers upward.

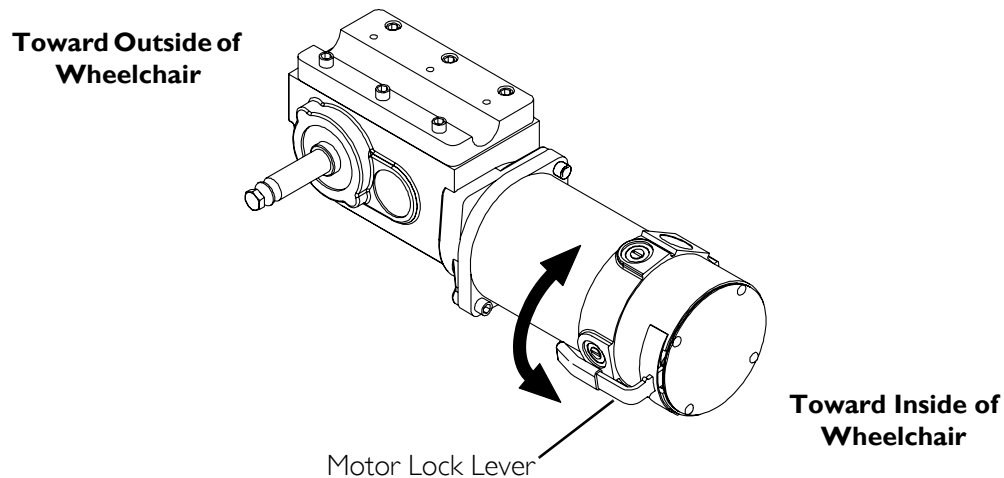

FIGURE 13.2 Disengaging/Engaging the Motor Lock Levers - R5 ILXP Only

SECTION 14—WHEEL LOCKS

⚠ WARNING

After ANY adjustments, repair or service and BEFORE use, make sure all attaching hardware is tightened securely. Otherwise, injury or damage may result.

NOTE: For this procedure, refer to FIGURE 14.1.

Installing/Adjusting/Using the Wheel Locks

⚠ WARNING

Wheel locks are an option on RWD (you can order with or without wheel locks). Transfer to and from the wheelchair in the presence of a qualified health care professional to determine individual safety limits. Invacare strongly recommends ordering the wheel locks as an additional safeguards for the wheelchair user.

Installing/Adjusting

NOTE: Before adjusting or replacing the wheel lock assemblies, ensure that the tires are inflated to the recommended psi on the side wall of tire.

NOTE: If necessary, remove threaded plastic insert from the wheel lock mounting hole in the wheelchair frame.

1. Position the wheel lock on the wheelchair frame.
2. Loosely install the hex screw and locknut that secures the wheel lock to the wheelchair frame.
3. Make sure wheel lock is disengaged from rear wheel.
4. Measure the distance between the wheel lock shoe and the rear wheel.
5. Slide the wheel lock along the wheelchair until the measurement is between 5/32 and 5/16-inches.
6. Tighten the wheel lock to the wheelchair frame.
7. Repeat STEPS 2-6 for the opposite wheel lock.
8. Disengage the clutches. Refer to Engaging/Disengaging the Clutches on page 65.
9. Engage the wheel locks and push against the wheelchair to determine if the wheel locks engage the rear wheels enough to hold the wheelchair.
10. Repeat STEPS 3-9 until the wheel locks engage the rear wheels enough to hold the wheelchair.
11. Engage clutches. Refer to Engaging/Disengaging the Clutches on page 65.

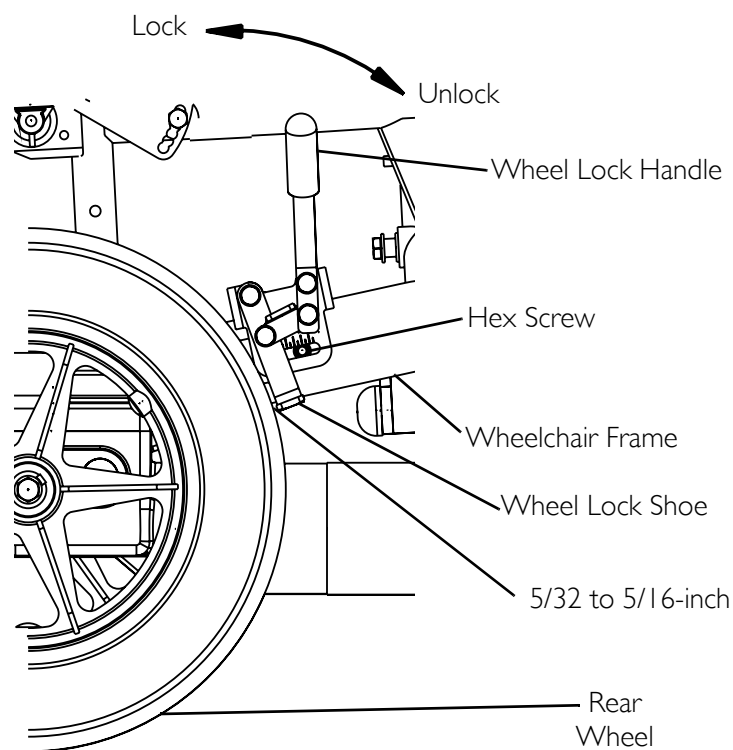

FIGURE 14.1 Installing/Adjusting/Using the Wheel Locks

Using

The wheelchair is equipped with a pair of independently operated wheel locks located just in front of the rear wheels.

1. To engage the wheel locks, grip the handle and push forward to the lock position.
2. To disengage, reverse STEP 1.

△ CAUTION

DO NOT use the wheel locks when the wheelchair power is on and the clutches are engaged - otherwise damage to the wheelchair may result.

NOTE: Use the wheel locks whenever the clutches are disengaged and the wheelchair is being pushed.

SECTION 15—ANTI-TIPPERS

⚠ WARNING

After **ANY** adjustments, repair or service and **BEFORE** use, make sure all attaching hardware is tightened securely - otherwise injury or damage may result.

Installing/Removing the Anti-Tippers

⚠ WARNING

Anti-tippers **MUST** be fully engaged and spring buttons fully protruding out of adjustment holes **BEFORE** using the wheelchair.

Ensure both anti-tippers have the same ground clearance.

A 1½ to 2-inch clearance between the bottom of the anti-tipper wheels and the ground/floor **MUST** be maintained at all times.

Anti-tippers **MUST** be used at all times. When outdoors on wet, soft ground or gravel surfaces, anti tippers may not provide the same level of protection against tipover. Extra caution must be observed when traversing such surfaces.

NOTE: For this procedure, refer to FIGURE 15.1.

Installing

1. Press the two (2) release buttons in and insert the anti-tippers with anti-tipper wheels pointing toward the ground/floor into the support tubes until the release buttons lock in place.
2. Measure the distance between the bottom of the anti-tipper wheels and the ground/floor.
3. If the distance between the bottom of the anti-tipper wheels and the ground/floor is not 1½-2-inches, do not use the anti-tippers. Replace anti-tippers and repeat STEPS 1 and 2.

Removing

1. Press release buttons in and remove the anti-tippers from the support tubes.

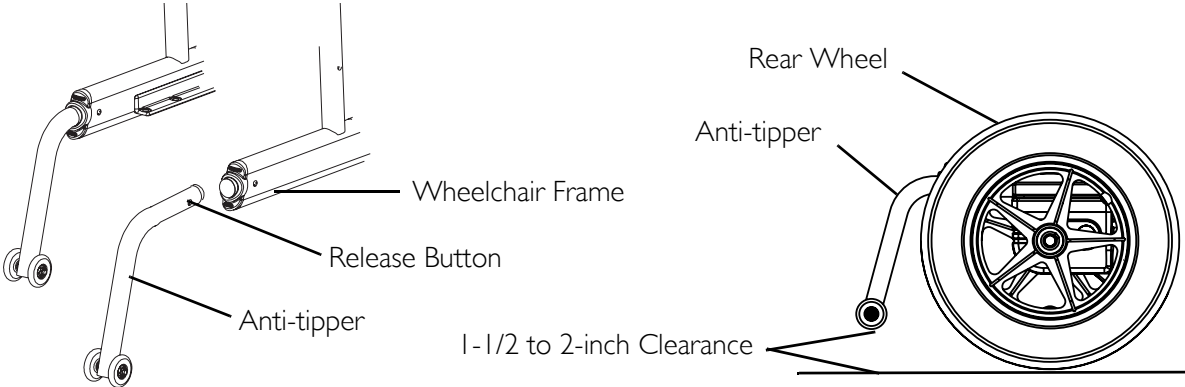

FIGURE 15.1 Installing/Removing the Anti-Tippers

SECTION 16—TRANSPORTING

⚠ WARNING

After **ANY** adjustments, repair or service and **BEFORE** use, make sure all attaching hardware is tightened securely - otherwise injury or damage may result.

Transporting the Neutron

⚠ WARNING

The weight of the wheelchair without the user and batteries is approximately 79 lbs. Use proper lifting techniques (lift with your legs) to avoid injury. Extreme caution is advised when it is necessary to move an unoccupied power wheelchair. Invacare recommends using two (2) assistants and making thorough preparations. Make sure to use **ONLY** secure, non-detachable parts for hand-hold supports.

NOTE: For this procedure, refer to FIGURE 16.1.

Unfolding/Folding the Wheelchair

⚠ WARNING

Keep hands and fingers clear of moving parts to avoid injury.

DO NOT place hand or fingers on the underside of the seat rail when opening or closing the wheelchair.

DO NOT sit or transfer into the wheelchair unless it is fully open and the seat rails are fully seated into the side frame H-blocks.

Unfolding

1. Push down on the seat rails until the seat rails are positioned in the seat guides.
2. Assemble the wheelchair by following the instructions in this manual.

Folding

1. Remove the anti-tippers. Refer to Installing/Removing the Anti-Tippers on page 69.
2. Remove the batteries. Refer to Installing/Removing the Battery Boxes on page 51.
3. Remove the footrests/legrests from the wheelchair. Refer to Installing/Removing the Footrests on page 31 or Installing/Removing Elevating Legrests on page 34.
4. Remove the battery tray from the wheelchair. Refer to Installing/Removing the Battery Tray on page 52.
5. Lift up on the seat rails of the wheelchair.

Refer to Installing/Removing the Battery Boxes on page 51
and Installing/Removing the Battery Tray on page 52.

Refer to Installing/Removing the Anti-Tippers
on page 69.

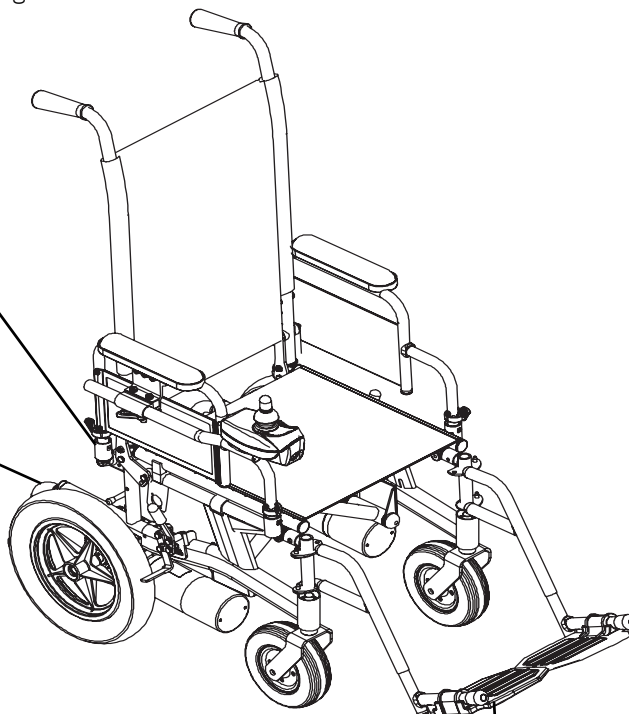

Refer to Installing/Removing the Footrests on page 31
or Installing/Removing Elevating Legrests on page 34.

FIGURE 16.1 Transporting the Nutron

NOTES

NOTES

LIMITED WARRANTY

PLEASE NOTE: THE WARRANTY BELOW HAS BEEN DRAFTED TO COMPLY WITH FEDERAL LAW APPLICABLE TO PRODUCTS MANUFACTURED AFTER JULY 4, 1975.

This warranty is extended only to the original purchaser/user of our products.

This warranty gives you specific legal rights and you may also have other legal rights which vary from state to state.

With regards to the original purchaser/user only, Invacare warrants the front and rear frames to be free from defects in materials and workmanship for a period of three (3) years from date of purchase; seat frame for a period of three (3) years from the date of purchase; electronics, motors and gearboxes for a period of one (1) year from the date of purchase; all remaining components for one (1) year from the date of purchase except upholstered materials, padded materials and tires/wheels. If within such warranty period any product shall be proven to be defective, such product shall be repaired or replaced, at Invacare's option. This warranty does not include any labor or shipping charges incurred in replacement part installation or repair of any such product. Invacare's sole obligation and your exclusive remedy under this warranty shall be limited to such repair and/or replacement.

For warranty service, please contact the dealer from whom you purchased your Invacare product. In the event you do not receive satisfactory warranty service, please write directly to Invacare at the address on the bottom of the back cover. Provide dealer's name address, date of purchase, indicate nature of the defect and, if the product is serialized, indicate the serial number. Do not return products to our factory without our prior consent.

LIMITATIONS AND EXCLUSIONS: THE FOREGOING WARRANTY SHALL NOT APPLY TO SERIAL NUMBERED PRODUCTS IF THE SERIAL NUMBER HAS BEEN REMOVED OR DEFACED, PRODUCTS SUBJECT TO NEGLIGENCE, ACCIDENT, IMPROPER OPERATION, MAINTENANCE OR STORAGE, COMMERCIAL OR INSTITUTIONAL USE, PRODUCTS MODIFIED WITHOUT INVACARE'S EXPRESS WRITTEN CONSENT INCLUDING, BUT NOT LIMITED TO, MODIFICATION THROUGH THE USE OF UNAUTHORIZED PARTS OR ATTACHMENTS; PRODUCTS DAMAGED BY REASON OF REPAIRS MADE TO ANY COMPONENT WITHOUT THE SPECIFIC CONSENT OF INVACARE, OR TO A PRODUCT DAMAGED BY CIRCUMSTANCES BEYOND INVACARE'S CONTROL, AND SUCH EVALUATION WILL BE SOLELY DETERMINED BY INVACARE. THE WARRANTY SHALL NOT APPLY TO PROBLEMS ARISING FROM NORMAL WEAR OR FAILURE TO ADHERE TO THESE INSTRUCTIONS. A CHANGE IN OPERATING NOISE, PARTICULARLY RELATIVE TO MOTORS AND GEARBOXES DOES NOT CONSTITUTE A FAILURE. ALL SUCH DEVICES WILL EXHIBIT A CHANGE IN OPERATING NOISE DUE TO AGING.

THE FOREGOING EXPRESS WARRANTY IS EXCLUSIVE AND IN LIEU OF ANY OTHER WARRANTIES WHATSOEVER, WHETHER EXPRESS OR IMPLIED, INCLUDING THE IMPLIED WARRANTIES OF MERCHANTABILITY AND FITNESS FOR A PARTICULAR PURPOSE, AND THE SOLE REMEDY FOR VIOLATIONS OF ANY WARRANTY WHATSOEVER, SHALL BE LIMITED TO REPAIR OR REPLACEMENT OF THE DEFECTIVE PRODUCT PURSUANT TO THE TERMS CONTAINED HEREIN, THE APPLICATION OF ANY IMPLIED WARRANTY WHATSOEVER SHALL NOT EXTEND BEYOND THE DURATION OF THE EXPRESS WARRANTY PROVIDED HEREIN. INVACARE SHALL NOT BE LIABLE FOR ANY CONSEQUENTIAL OR INCIDENTAL DAMAGES WHATSOEVER.

THIS WARRANTY SHALL BE EXTENDED TO COMPLY WITH STATE/PROVINCIAL LAWS AND REQUIREMENTS.



Yes, you can.™

Invacare Corporation www.invacare.com

USA
One Invacare Way
Elyria, Ohio USA
44036-2125
800-333-6900

Canada
570 Matheson Blvd E Unit 8
Mississauga Ontario
L4Z 4G4 Canada
800-668-5324

Invacare and Nutron are registered trademarks of Invacare Corporation. Yes, you can., MK5, EX, NX, R50, R51, and SPJ are trademarks of Invacare Corporation
© 2004 Invacare Corporation

Part No. I106645

Rev C - 10/04