

Ranger II Storm Series[®]
Wheelchairs
RWD

R2_{BASIC}
R2_{STANDARD}
R2_{250-S}

DEALER: THIS MANUAL MUST BE GIVEN TO THE USER
OF THE WHEELCHAIR.

USER: BEFORE USING THIS WHEELCHAIR, READ THIS
MANUAL AND SAVE FOR FUTURE REFERENCE.



Yes, you can.™

WARNING

DO NOT OPERATE THIS EQUIPMENT WITHOUT FIRST READING AND UNDERSTANDING THIS MANUAL. IF YOU ARE UNABLE TO UNDERSTAND THE WARNINGS, CAUTIONS, AND INSTRUCTIONS, CONTACT A HEALTHCARE PROFESSIONAL, DEALER OR TECHNICAL PERSONNEL IF APPLICABLE BEFORE ATTEMPTING TO USE THIS EQUIPMENT - OTHERWISE INJURY OR DAMAGE MAY RESULT.

SPECIAL NOTES

WARNING/CAUTION notices as used in this manual apply to hazards or unsafe practices which could result in personal injury or property damage.

NOTICE

THE INFORMATION CONTAINED IN THIS DOCUMENT IS SUBJECT TO CHANGE WITHOUT NOTICE.

WHEELCHAIR USER

As a manufacturer of wheelchairs, Invacare endeavors to supply a wide variety of wheelchairs to meet many needs of the end user. However, final selection of the type of wheelchair to be used by an individual rests solely with the user and his/her healthcare professional capable of making such a selection.

WHEELCHAIR TIE-DOWN RESTRAINTS AND SEAT POSITIONING STRAPS

Invacare recommends that wheelchair users NOT be transported in vehicles of any kind while in wheelchairs. As of this date, the Department of Transportation has not approved any tie-down systems for transportation of a user while in a wheelchair, in a moving vehicle of any type.

It is Invacare's position that users of wheelchairs should be transferred into appropriate seating in vehicles for transportation and use be made of the restraints made available by the auto industry. Invacare cannot and does not recommend any wheelchair transportation systems.

AS REGARDS RESTRAINTS - SEAT POSITIONING STRAPS - IT IS THE OBLIGATION OF THE DME DEALER, THERAPISTS AND OTHER HEALTH CARE PROFESSIONALS TO DETERMINE IF A SEAT POSITIONING STRAP IS REQUIRED TO ENSURE THE SAFE OPERATION OF THIS EQUIPMENT BY THE USER. SERIOUS INJURY CAN OCCUR IN THE EVENT OF A FALL FROM A WHEELCHAIR.

SAVE THESE INSTRUCTIONS

TABLE OF CONTENTS

The following procedures refer to R2^{STANDARD}, R2^{BASIC} and R2^{250-S} except where specified.

SPECIAL NOTES	2	PROCEDURE 8 - BATTERIES	32
SPECIFICATIONS	4	INSTALLING/REMOVING BATTERIES	
PROCEDURE 1 - GENERAL GUIDELINES	5	INTO/FROM BATTERY BOXES	32
REPAIR OR SERVICE INFORMATION	5	CONNECTING BATTERY CABLES	32
OPERATING INFORMATION	5	WHEN TO CHARGE BATTERIES	37
SAFETY/HANDLING OF WHEELCHAIRS	6	CHARGING BATTERIES	37
PROCEDURE 2 - SAFETY INSPECTION		REPLACING BATTERIES	38
CHECKLIST/TROUBLESHOOTING	11	INSTALLING/REMOVING BATTERY TRAY	39
SAFETY INSPECTION CHECKLIST	11	INSTALLING/REMOVING BATTERY BOXES	39
TROUBLESHOOTING - MECHANICAL	12	PROCEDURE 9 - ELECTRONICS	40
TROUBLESHOOTING - ELECTRICAL	12	PREPARING MKIV JOYSTICK FOR USE	40
CHECKING BATTERY CHARGE LEVEL	12	DISCONNECTING/CONNECTING MKIV	
MOTOR TESTING	14	CONTROLLER MOTOR AND BATTERY	
MOTOR BRUSH INSPECTION	15	LEADS	40
MOTOR LOCK TESTING	15	REPOSITIONING MKIV JOYSTICK	40
PROCEDURE 3 - ASSEMBLY/TRANSPORTING ...	16	REMOVING/INSTALLING MKIV	
ASSEMBLING/TRANSPORTING	16	CONTROLLER	41
PROCEDURE 4 - FRONT RIGGINGS	17	PROCEDURE 10 - RETAINING STRAP	42
INSTALLING/REMOVING FOOTRESTS	17	REPLACING BATTERY BOX RETAINING	
ADJUSTING FOOTREST HEIGHT	17	STRAP	42
REPLACING HEEL LOOPS	18	PROCEDURE 11 - WIRING HARNESS	43
INSTALLING/REMOVING ELEVATING		REPLACING WIRING HARNESS	43
LEGRESTS	18	PROCEDURE 12 - WHEELS/ANTI-TIPPER	44
RAISING/LOWERING ELEVATING LEGRESTS		DISENGAGING/ENGAGING MOTORS	
AND/OR ADJUSTING CALFPADS	19	WITH MOTOR LOCKS	44
ADJUSTING/REPLACING TELESCOPING		DISENGAGING/ENGAGING MOTORS	
FRONT RIGGING SUPPORT	19	WITH CLUTCHES	44
PROCEDURE 5 - ARMS	20	USING/INSTALLING/ADJUSTING WHEEL	
ADJUSTING ARMREST HEIGHT, REMOVING		LOCKS	45
OR REPLACING ARMRESTS	20	REPLACING PNEUMATIC TIRES AND TUBES -	
INSTALLING/REMOVING FLIP BACK		FRONT CASTERS AND REAR WHEELS	46
ARMRESTS - NON-RECLINER WHEELCHAIRS		INSTALLING/REPLACING REAR WHEELS	46
BUILT AFTER 10/2000 ONLY	20	INSTALLING/REPLACING FRONT CASTERS	47
ADJUSTING FLIP BACK ARMRESTS		REPLACING FRONT FORK	47
- NON-RECLINER WHEELCHAIRS BUILT		INSTALLING/REMOVING ANTI-TIPPERS	47
AFTER 10/2000 ONLY	21	INSTALLING OPTIONAL CLUTCH	
PROCEDURE 6 - UPHOLSTERY/		EXTENSION HANDLES - MOTORS	
POSITIONING STRAP	22	WITH CLUTCHES ONLY	48
REPLACING SEAT UPHOLSTERY	22	PROCEDURE 13 - MOTOR/GEARBOX	49
REPLACING SEAT POSITIONING STRAP	22	REPLACING MOTOR/GEARBOX	49
REPLACING BACK UPHOLSTERY	22	PROCEDURE 14 - RECLINER	50
PROCEDURE 7 - FRAME	25	RECLINER OPERATION	50
ADJUSTING SEAT WIDTH	25	REPLACING BACK OR HEADREST	
ADJUSTING SEAT DEPTH	26	UPHOLSTERY	50
INSTALLING BACK ASSEMBLY		ADJUSTING BACK OR HEADREST	
- WHEELCHAIRS BEFORE 10/2000 ONLY ..	26	UPHOLSTERY	51
CHANGING BACK HEIGHT	27	REPLACING LIMIT SWITCH/ACTUATOR	51
CHANGING BACK ANGLE	29	ADJUSTING LIMIT SWITCH	52
REPLACING BACK CANES - WHEELCHAIRS		REPLACING RECLINER CABLE	
AFTER 10/2000 ONLY	30	ASSEMBLIES	52
		REPLACING/ADJUSTING GAS CYLINDERS	53
		CHANGING BACK HEIGHT	55
		LIMITED WARRANTY	BACK COVER

SPECIFICATIONS

NOTE: All specifications are approximate.

SPECIFICATIONS

RANGER II STORM SERIES			
	R2_{250-S}	R2_{BASIC} and R2_{STANDARD}	
		ADULT FRAME	LOW FRAME
Seat Width Range:	16, 18 or 20-in.	14, 16, 18 or 20-in.	16, 18 or 20-in.
Seat Depth Range:	16, 17 or 18-in. (17 and 18-inch by extension)	16, 17 or 18-in. (17 and 18-inch by extension)	
Back Height Range:	16, 17, 18, 19 or 20-in.	16, 17, 18, 19 or 20-in.	
Back Angle Range:	90° to 105° - in 5° increments	90° to 105° - in 5° increments	
Seat-to-Floor:	18-in.	20-1/4-in.	18-in.
Overall Width (No joystick):	24-5/8 to 26-1/2-in.	24-5/8 to 26-1/2-in.	
Overall Height:	34-3/4 to 38-3/4-in.	36 to 40-in.	34-3/4 to 38-3/4-in.
Overall Length (with 93 front riggings):	42 to 44-3/4-inches (16-inch seat depth)	42 to 44-3/4-inches (16-inch seat depth)	
* Weight		BASIC	STANDARD
W/O Batteries:	94 lbs.	94 lbs.	101 lbs.
W/ Batteries (Gel Cell):	145 lbs.	169-159 lbs.	176-166 lbs.
Shipping:	128-133 lbs.	128-133 lbs.	135-140 lbs.
Rear Wheels/Tires: (Foam Filled or Pneumatic)	12-1/2 x 2-1/4 inches	12-1/2 x 2-1/4 inches	
Casters w/Precision Sealed Bearings:	8 x 1-3/4-inches Semi Pneumatic	8 x 1-3/4-inches Semi Pneumatic (Std) 8 x 2-inches Pneumatic (Opt)	
Anti-Tippers:	Rotating, Removable	Rotating, Removable	
Footrest:	Swingaway, Removable	Swingaway, Removable	
Armrests:	Flip Back Arms - Fixed (Std) or Adjustable (Opt) Height - Desk or Full Length	Flip Back Arms - Fixed (Std) or Adjustable (Opt) Height - Desk or Full Length	
Upholstery:	Black Nylon	Black Nylon	
Battery/Size (Not Supplied) (Two (2) Required):	U1	14-inch Width - U1 16, 18 and 20-inch Widths - 22NF	

** NOTE: 18-inch wide x 16-inch deep wheelchair with MKIV RII electronics.*

Performance

	R2_{250-S}	R2_{BASIC}	R2_{STANDARD}
Speed (M.P.H.):	0 to 3.6	0 to 4.5	0 to 5.5
** Range (variable):	12-14 miles	12-14 miles - U1 batteries 18-22 miles- 22NF batteries	12-14 miles - U1 batteries 18-22 miles- 22NF batteries
*** Weight Limitation:	250 lbs.	250 lbs.	300 lbs.

***NOTE: Range will vary with battery conditions, surface, terrain and operators weight.*

****NOTE: Includes seating systems and accessories.*

This Procedure Includes the Following:***Repair or Service Information******Operating Information******Safety/Handling of Wheelchairs*****REPAIR OR SERVICE INFORMATION**

Set-up of the Electronic Control Unit is to be performed **ONLY** by qualified technicians. The final tuning adjustments of the controller may affect other activities of the wheelchair. Damage to the equipment could occur under these circumstances. If any individual other than a qualified technician performs any work on these units, the warranty is void.

OPERATING INFORMATION**GENERAL WARNINGS**

Performance adjustments should only be made by professionals of the healthcare field or persons fully conversant with this process and the driver's capabilities. Incorrect settings could cause injury to the driver, bystanders, damage to the chair and to surrounding property.

After the wheelchair has been set-up, check to make sure that the wheelchair performs to the specifications entered during the set-up procedure. If the wheelchair does **NOT** perform to specifications, turn the wheelchair **OFF** immediately and reenter set-up specifications. Repeat this procedure until the wheelchair performs to specifications.

DO NOT shift your weight or sitting position toward the direction you are reaching as the wheelchair may tip over.

DO NOT engage or disengage the motor locks/clutches until the power is in the **OFF** position.

Wheel locks are an **OPTION** on this wheelchair, (you may order with or without wheel locks). Invacare strongly recommends ordering the wheel locks as an additional safeguard for the wheelchair user. Transfer to and from the wheelchair in the presence of a qualified healthcare professional to determine individual safety limits.

DO NOT operate on roads, streets or highways.

DO NOT climb, go up or down ramps or traverse slopes greater than 9°.

DO NOT attempt to move up or down an incline with a water, ice or oil film.

DO NOT attempt to drive over curbs or obstacles. Doing so may cause your wheelchair to turn over and cause bodily harm or damage to the chair.

DO NOT use parts, accessories, or adapters other than those authorized by Invacare.

DO NOT leave the power button **ON** when entering or exiting your wheelchair.

DO NOT stand on the frame of the wheelchair.

DO NOT use the footplates as a platform. When getting in or out of the wheelchair, make sure that the footplates are in the upward position or swing footrests towards the outside of the chair.

ALWAYS wear your seat positioning strap.

TIRE PRESSURE

DO NOT use your wheelchair unless it has the proper tire pressure (P.S.I.). **DO NOT** overinflate the tires. Failure to follow these suggestions may cause the tire to explode and cause bodily harm. The recommended tire pressure is listed on the side wall of the tire.

ELECTRICAL

EXTREME care should be exercised when using oxygen in close proximity to electric circuits. Contact your oxygen supplier for instruction in the use of oxygen.

GENERAL WARNINGS (CONTINUED)

GENERAL GUIDELINES

Grounding Instructions:

DO NOT, under any circumstances, cut or remove the round grounding prong from any plug used with or for Invacare products. Some devices are equipped with three-prong (grounding) plugs for protection against possible shock hazards. Where a two-prong wall receptacle is encountered, it is the personal responsibility and obligation of the customer to contact a qualified electrician and have the two-prong receptacle replaced with a properly grounded three-prong wall receptacle in accordance with the National Electrical Code. If you must use an extension cord, use ONLY a three-wire extension cord having the same or higher electrical rating as the device being connected. In addition, Invacare has placed RED/ORANGE WARNING TAGS on some equipment. DO NOT remove these tags.

BATTERIES

Only deep cycle, sealed case construction batteries should be used.

Carefully read battery/battery charger information prior to installing, servicing or operating your wheelchair.

RAIN TEST

INVACARE has tested its power wheelchairs in accordance with ISO 7176 Part 9 "Rain Test". This provides the end user or his/her assistant sufficient time to remove his/her power wheelchair from a rain storm and retain wheelchair operation.

DO NOT leave power wheelchair in a rain storm of any kind.

DO NOT use power wheelchair in a shower or leave it in a damp bathroom while taking a shower.

DO NOT leave power wheelchair in a damp area for any length of time.

Direct exposure to rain or dampness will cause the chair to malfunction electrically and mechanically; may cause the chair to prematurely rust.

Check to ensure that the battery covers are secured in place, joystick boot is NOT torn or cracked where water can enter and that all electrical connections are secure at all times.

DO NOT use the joystick if the boot is torn or cracked. If the joystick boot becomes torn or cracked, replace IMMEDIATELY.

WEIGHT TRAINING

Invacare DOES NOT recommend the use of its wheelchairs as a weight training apparatus. Invacare wheelchairs have NOT been designed or tested as a seat for any kind of weight training. If occupant uses said wheelchair as a weight training apparatus, INVACARE SHALL NOT BE LIABLE FOR BODILY INJURY AND THE WARRANTY IS VOID.

WEIGHT LIMITATION

The R2_{BASIC} has a weight limitation of 250 lbs. The R2_{STANDARD} has a weight limitation of 300 lbs.

The R2_{250-S} has a weight limitation of 250 lbs.

SAFETY/HANDLING OF WHEELCHAIRS

"Safety and Handling" of the wheelchair requires the close attention of the wheelchair user as well as the assistant. This manual points out the most common procedures and techniques involved in the safe operation and maintenance of the wheelchair. It is important to practice and master these safe techniques until you are comfortable in maneuvering around the frequently encountered architectural barriers.

Use this information only as a "basic" guide. The techniques that are discussed on the following pages have been used successfully by many.

Individual wheelchair users often develop skills to deal with daily living activities that may differ from those described in this manual.

Invacare recognizes and encourages each individual to try what works best for him/her in overcoming architectural obstacles that they may encounter, however, ALL WARNINGS and CAUTIONS given in this manual MUST be followed. Techniques in this manual are a starting point for the new wheelchair user and assistant with "safety" as the most important consideration for all.

Stability and Balance

WARNING

ALWAYS wear your seat positioning strap.

To assure stability and proper operation of your wheelchair, you must at all times maintain proper balance. Your wheelchair has been designed to remain upright and stable during normal daily activities as long as you do not move beyond the center of gravity. **DO NOT** lean forward out of the wheelchair any further than the length of the armrests.

Coping With Everyday Obstacles

Coping with the irritation of everyday obstacles can be alleviated somewhat by learning how to manage your wheelchair. Keep in mind your center of gravity to maintain stability and balance.

A Note to Wheelchair Assistants

When assistance to the wheelchair user is required, remember to use good body mechanics. Keep your back straight and bend your knees whenever tilting wheelchair or traversing curbs, or other impediments.

WARNING

DO NOT attempt to lift the wheelchair by any removable (detachable) parts. Lifting by means of any removable (detachable) parts of a wheelchair may result in injury to the user or damage to the wheelchair.

Also, be aware of detachable parts such as arms or leg-rests. These must **NEVER** be used for hand-hold or lifting supports, as they may be inadvertently released, resulting in possible injury to the user and/or assistant(s).

When learning a new assistance technique, have an experienced assistant help you before attempting it alone.

Percentage of Weight Distribution

WARNING

DO NOT attempt to reach objects if you have to move forward in the seat or pick them up from the floor by reaching down between your knees.

Many activities require the wheelchair user to reach, bend and transfer in and out of the wheelchair. These movements will cause a change to normal balance, center of gravity, and weight distribution of the wheelchair. To determine and establish your particular safety limits, practice bending, reaching and transferring activities in several combinations in the presence of a qualified healthcare professional **BEFORE** attempting active use of the wheelchair.

WARNING

Proper positioning is essential for your safety. When reaching, leaning, bending or bending forward, it is important to use the rear casters as a tool to maintain stability and balance.

Functional Reach From a Wheelchair

The approximate reach-limit values shown in the accompanying graphs were derived on the basis of a sample of 91 male and 36 female wheelchair users. Note the difference between the maximum and the comfortable reach limits, a subjective but important consideration in design.

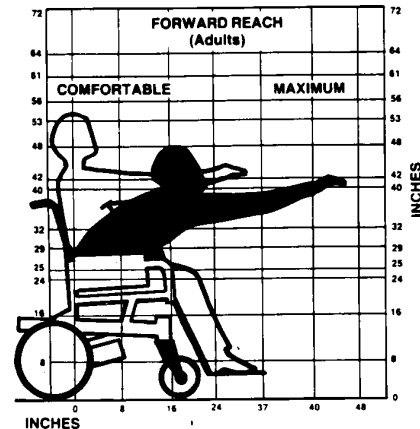

Reaching, Leaning, Bending and Bending - Forward

Position the rear casters so that they are extended as far forward as possible and engage motor locks/clutches.

WARNING

DO NOT attempt to reach objects if you have to move forward in the seat or pick them up from the floor by reaching down between your knees.

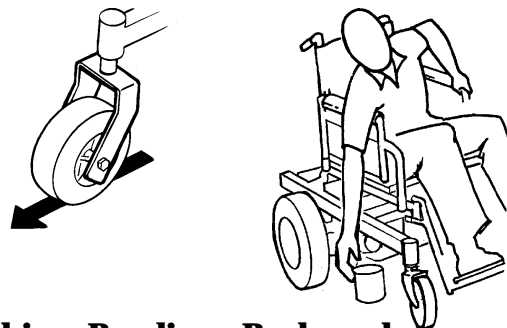

Reaching, Bending - Backward

WARNING

DO NOT lean over the top of the back upholstery. This will change your center of gravity and may cause you to tip over.

Position wheelchair as close as possible to the desired object. Point rear casters rearward to create the longest possible wheelbase. Reach back only as far as your arm will extend without changing your sitting position.



Stairways

WARNING

DO NOT attempt to move an occupied power wheelchair between floors using a stairway. Use an elevator to move an occupied power wheelchair between floors. If moving a power wheelchair between floors by means of a stairway, the occupant **MUST** be removed and transported independently of the power wheelchair.

Extreme caution is advised when it is necessary to move an **UNOCCUPIED** power wheelchair up or down the stairs. Invacare recommends using two (2) assistants and making thorough preparations. Make sure to use **ONLY** secure, non-detachable parts for hand-hold supports.

DO NOT attempt to lift the wheelchair by any removable (detachable) parts. Lifting by means of any removable (detachable) parts of a wheelchair may result in injury to the user or damage to the wheelchair.

Follow this procedure for moving the wheelchair between floors when an elevator is **NOT** available:

WARNING

The weight of the wheelchair without the user and batteries is still between 94 and 101 lbs. Use proper lifting techniques (lift with your legs) to avoid injury.

1. Remove the occupant from the wheelchair.
2. Remove the battery boxes from the rear of the wheelchair. Refer to INSTALLING/REMOVING BATTERY BOXES in PROCEDURE 8 of this manual.
3. Turn the anti-tippers so the wheels are pointing UP.
4. **Disengage the following:**

MOTORS w/MOTOR LOCKS - Motor locks. Refer to DISENGAGING/ENGAGING MOTORS WITH MOTOR LOCKS in PROCEDURE 12 of this manual.

MOTORS w/CLUTCHES - Clutches. Refer to DISENGAGING/ENGAGING MOTORS WITH CLUTCHES in PROCEDURE 12 of this manual.

5. After the wheelchair has been tilted back to the balance point, one assistant (in the rear) backs the wheelchair up against the first step, while securely grasping a non-removable (non-detachable) part of the wheelchair for leverage.
6. The second assistant, with a firm hold on a non-detachable part of the framework, lifts the wheelchair up and over the stair and steadies the wheelchair as the first assistant places one (1) foot on the next stair and repeats STEP 1.
7. The wheelchair should not be lowered until the last stair has been negotiated and the wheelchair has been rolled away from the stairway.

WARNING

Make sure anti-tipper wheels are pointing down towards ground/floor **BEFORE** using wheelchair.

8. Turn anti-tipper wheels down towards the ground/floor.
9. **Engage the following:**
MOTORS w/MOTOR LOCKS - Motor locks. Refer to DISENGAGING/ENGAGING MOTORS WITH MOTOR LOCKS in PROCEDURE 12 of this manual.
MOTORS w/CLUTCHES - Clutches. Refer to DISENGAGING/ENGAGING MOTORS WITH CLUTCHES in PROCEDURE 12 of this manual.

ESCALATORS? SORRY!

DO NOT use an escalator to move a wheelchair between floors. Serious bodily injury may occur.

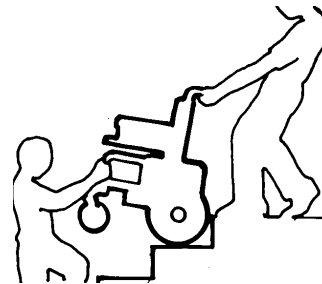

Transferring to and From Other Seats

WARNING

ALWAYS turn the wheelchair power OFF and engage the motor locks/clutches to prevent the wheels from moving **BEFORE** attempting to transfer in or out of the wheelchair. Also, make sure every precaution is taken to reduce the gap distance by turning both rear casters parallel to the object you are transferring onto.

CAUTION

When transferring, position yourself as far back as possible in the seat. This will prevent broken screws, damaged upholstery and the possibility of the wheelchair tipping forward.

NOTE: This activity may be performed independently provided you have adequate mobility and upper body strength.

1. Position the wheelchair as close as possible along side the seat to which you are transferring, with the rear casters parallel to it.
2. **Engage the following:**
MOTORS w/MOTOR LOCKS - Motor locks. Refer to DISENGAGING/ENGAGING MOTORS WITH MOTOR LOCKS in PROCEDURE 12 of this manual.
MOTORS w/CLUTCHES - Clutches. Refer to DISENGAGING/ENGAGING MOTORS WITH CLUTCHES in PROCEDURE 12 of this manual.
3. Shift body weight into seat with transfer.

During independent transfer, little or no seat platform will be beneath you. Use a transfer board if at all possible.



Tilting

WARNING
DO NOT tilt the wheelchair without assistance.

When tilting the wheelchair, an assistant should grasp the back of the wheelchair on a non-removable (non-detachable) part. Inform the wheelchair occupant before tilting the wheelchair and remind him/her to lean back. Be sure the occupant's feet and hands are clear of all wheels.

TILTING - CURBS.

After mastering the techniques of tilting the wheelchair, use this procedure to tackle curbs, short stairs, etc.

This procedure requires two (2) assistants. The second assistant should be positioned at the front of the wheelchair lifting upward on a non-removable (non-detachable) part of the wheelchair frame when lifting the wheelchair and stabilizing the wheelchair when the wheelchair is being lowered to the ground.

The first assistant should turn the anti-tippers so the wheels are pointing up, apply a continuous downward motion until the balance point is achieved and the front casters clear the curb. At this point, the assistants will feel a difference in the weight distribution.

Roll the wheelchair forward and slowly lower the wheelchair in one continuous movement. Do not let the wheelchair drop the last few inches to the ground. This could result in injury to the occupant. Push the wheelchair forward until the rear wheels roll up and over the curb.

WARNING
Make sure anti-tipper wheels are pointing down towards ground/floor BEFORE using wheelchair.

Turn the anti-tipper wheels down towards the ground/floor.

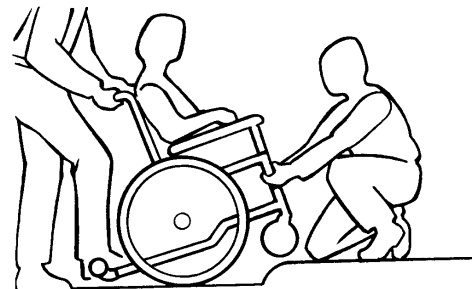

TILTING: CURBS

WARNING

CAUTION: IT IS VERY IMPORTANT THAT YOU READ THIS INFORMATION REGARDING THE POSSIBLE EFFECTS OF ELECTROMAGNETIC INTERFERENCE ON YOUR POWERED WHEELCHAIR.

Electromagnetic Interference (EMI) From Radio Wave sources

Powered wheelchairs and motorized scooters (in this text, both will be referred to as powered wheelchairs) may be susceptible to electromagnetic interference (EMI), which is interfering electromagnetic energy (EM) emitted from sources such as radio stations, TV stations, amateur radio (HAM) transmitters, two way radios, and cellular phones. The interference (from radio wave sources) can cause the powered wheelchair to release its brakes, move by itself, or move in unintended directions. It can also permanently damage the powered wheelchair's control system. The intensity of the interfering EM energy can be measured in volts per meter (V/m). Each powered wheelchair can resist EMI up to a certain intensity. This is called its "immunity level." The higher the immunity level, the greater the protection. At this time, current technology is capable of achieving at least a 20 V/m immunity level, which would provide useful protection from the more common sources of radiated EMI. This powered wheelchair model as shipped has an unknown immunity level.

WARNING

There are a number of sources of relatively intense electromagnetic fields in the everyday environment. Some of these sources are obvious and easy to avoid. Others are not apparent and exposure is unavoidable. However, we believe that by following the warnings listed below, your risk to EMI will be minimized.

The sources of radiated EMI can be broadly classified into three types:

- 1) Hand-held Portable transceivers (transmitters-receivers with the antenna mounted directly on the transmitting unit. Examples include: citizens band (CB) radios, "walkie talkie", security, fire and police transceivers, cellular telephones, and other personal communication devices. ****NOTE:** Some cellular telephones and similar devices transmit signals while they are ON, even when not being used;
- 2) Medium-range mobile transceivers, such as those used in police cars, fire trucks, ambulances, and taxis. These usually have the antenna mounted on the outside of the vehicle; and
- 3) Long-range transmitters and transceivers, such as commercial broadcast transmitters (radio and TV broadcast antenna towers) and amateur (HAM) radios.

NOTE: Other types of hand-held devices, such as cordless phones, laptop computers, AM/FM radios, TV sets, CD players, cassette players, and small appliances, such as electric shavers and hair dryers, so far as we know, are not likely to cause EMI problems to your powered wheelchair.

Powered Wheelchair Electromagnetic Interference (EMI)

Because EM energy rapidly becomes more intense as one moves closer to the transmitting antenna (source), the EM fields from hand-held radio wave sources (transceivers) are of special concern. It is possible to unintentionally bring high levels of EM energy very close to the powered wheelchair's control system while using these devices. This can affect powered wheelchair movement and braking. Therefore, the warnings listed below are recommended to prevent possible interference with the control system of the powered wheelchair.

Electromagnetic interference (EMI) from sources such as radio and TV stations, amateur radio (HAM) transmitters, two-way radios, and cellular phones can affect powered wheelchairs and motorized scooters. Following the warnings listed below should reduce the chance of unintended brake release or powered wheelchair movement which could result in serious injury.

- 1) Do not operate hand-held transceivers (transmitters receivers), such as citizens band (CB) radios, or turn ON personal communication devices, such as cellular phones, while the powered wheelchair is turned ON;
- 2) Be aware of nearby transmitters, such as radio or TV stations, and try to avoid coming close to them;
- 3) If unintended movement or brake release occurs, turn the powered wheelchair OFF as soon as it is safe;
- 4) Be aware that adding accessories or components, or modifying the powered wheelchair, may make it more susceptible to EMI (Note: There is no easy way to evaluate their effect on the overall immunity of the powered wheelchair); and
- 5) Report all incidents of unintended movement or brake release to the powered wheelchair manufacturer, and note whether there is a source of EMI nearby.

Important Information

- 1) 20 volts per meter (V/m) is a generally achievable and useful immunity level against EMI (as of May 1994) (the higher the level, the greater the protection);
- 2) The MKIV-RII has an unknown immunity level.

Modification of any kind to the electronics of this wheelchair as manufactured by Invacare may adversely affect the RFI immunity levels.

S A F E T Y I N S P E C T I O N

T R O U B L E S H O O T I N G

- This Procedure Includes the Following:***
- Safety Inspection Checklist***
 - Troubleshooting - Mechanical***
 - Troubleshooting - Electrical***
 - Checking Battery Charge Level***
 - Motor Testing***
 - Motor Brush Inspection***
 - Motor Lock Testing***

SAFETY INSPECTION CHECKLIST

Initial adjustments should be made to suit personal body structure and preference. Thereafter follow these maintenance procedures:

ITEM	INITIALLY	INSPECT/ ADJUST WEEKLY	INSPECT/ ADJUST MONTHLY	INSPECT/ ADJUST PERIODICALLY
GENERAL (MECHANICAL TROUBLESHOOTING) ● Wheelchair rolls straight (no excessive drag or pull to one side).	X			X
CLOTHING GUARDS ● Ensure all fasteners are secure.	X			X
ARMS - (PROCEDURE 5) ● Secure but easy to release; adjustment levers engage properly. ● Inspect for rips in upholstery. ● Armrest pad sits flush against arm tube.	X X X			X X X
*WHEEL LOCKS - (PROCEDURE 12) ● Do not interfere with tires when rolling. ● Pivot points free of wear and looseness. ● Wheel locks easy to engage.	X X X		X X	X
SEAT AND BACK UPHOLSTERY - (PROCEDURE 6) ● Inspect for rips or sagging.	X			
REAR WHEELS - (PROCEDURE 12) ● Axle bolts and locking tab washers are secure. ● No excessive side movement or binding when lifted and spun when disengaged (free-wheeling).	X X			X
FRONT CASTERS - (PROCEDURE 12) ● Inspect wheel/fork assembly for proper tension by spinning caster; caster should come to a gradual stop. ● Loosen/tighten locknut if wheel wobbles noticeably or binds to a stop. CAUTION: As with any vehicle, the wheels and tires should be checked periodically for cracks and wear, and should be replaced.	X X		X X	
CASTER/WHEEL/FORK/HEAD TUBE - (PROCEDURE 12) ● Ensure all fasteners are secure.	X	X		
TIRES - (PROCEDURE 12) ● Inspect for flat spots and wear. ● If pneumatic tires check for proper inflation. CAUTION: As with any vehicle, the wheels and tires should be checked periodically for cracks and wear, and should be replaced.	X X	X X		
CLEANING ● Clean upholstery and armrests.	X			X

NOTE: Every six (6) months take your wheelchair to a qualified technician for a thorough inspection and servicing. Regular cleaning will reveal loose or worn parts and enhance the smooth operation of your wheelchair. To operate properly and safely, your wheelchair must be cared for just like any other vehicle. Routine maintenance will extend the life and efficiency of your wheelchair.

WARNING

***Wheel locks are an OPTION on this wheelchair, (you may order with or without wheel locks). Transfer to and from the wheelchair in the presence of a qualified healthcare professional to determine individual safety limits. Invacare strongly recommends ordering the wheel locks as an additional safeguard for the wheelchair user.**

TROUBLESHOOTING - MECHANICAL

CHAIR VEERS LEFT/RIGHT	SLUGGISH TURN/ PERFORMANCE	CASTERS FLUTTER	SQUEAKS AND RATTLES	LOOSENESS IN CHAIR	CHAIR 3 WHEELS	SOLUTIONS
X	X	X			X	If pneumatic, check tires for correct and equal pressure.
X	X	X	X	X		Check for loose stem nuts/bolts.
X		X				Check that both casters contact ground at the same time.

TROUBLESHOOTING - ELECTRICAL

SYMPTOM	PROBABLE CAUSE	SOLUTIONS
Batteries draw excessive current when charging.	Battery failure. Electrical malfunction.	Check batteries for shorted cell. Replace if necessary (PROCEDURE 8). Contact Dealer/Invacare for Service.
Battery indicator flashes the charge level is low—immediately after re-charge.	Battery failure. Malfunctioning battery charger. Electrical malfunction.	Check batteries for shorted cell. Replace if necessary (PROCEDURE 8). Contact Dealer/Invacare for Service. Poor connections between charger and wheelchair. Contact Dealer/Invacare for Service.
Battery indicator flashes the charge level is low—too soon after being recharged.	Batteries not charged. Weak batteries. Electrical malfunction.	Have charger checked. Replace batteries if necessary (PROCEDURE 8). Contact Dealer/Invacare for Service.
Motor “chatters” or runs irregular.	Electrical malfunction.	Contact Dealer/Invacare for Service.
Wheelchair does not respond to commands. Power “ON”, battery indicator flashes.	One (1) or both motor locks/clutches disengaged.	Engage motor locks/clutches (PROCEDURE 12).
Only one (1) rear wheel turns.	Electrical malfunction. One (1) motor lock/clutch is disengaged.	Contact Dealer/Invacare for Service. Engage motor lock/clutch (PROCEDURE 12).
Joystick erratic or does not respond as desired.	Electrical malfunction. Controller Programed improperly.	Contact Dealer/Invacare for Service. Reprogram controller (Refer to MCC-MKIV controller manual supplied with wheelchair).
Wheelchair does not respond to commands. Power indicator OFF—even after recharging.	Poor battery terminal connection. Electrical malfunction.	Clean terminals (PROCEDURE 8). Contact Dealer/Invacare for Service.

NOTE: For additional troubleshooting information and explanation of error codes, refer to the individual CONTROLLER MANUAL supplied with each wheelchair.

CHECKING BATTERY CHARGE LEVEL (FIGURE 1)

WARNING

Invacare recommends that the following procedures be performed by a qualified service technician.

The following “Do’s” and “Don’ts” are provided for your convenience and safety.

DON'T	DO
Don't perform any installation or maintenance without first reading this manual.	Read and understand this manual and any service information that accompanies a battery and charger before operating the wheelchair.
Don't perform installation or maintenance of batteries in an area that could be damaged by battery spills.	Move the wheelchair to a work area before checking the fluid level, adding distilled water, cleaning terminals, or opening battery box.
Don't make it a habit to discharge batteries to the lowest level.	Recharge as frequently as possible to maintain a high charge level and extend battery life.
Don't use randomly chosen batteries/chargers.	Follow recommendations in this manual when selecting a battery or charger.
Don't put new batteries into service before charging.	Fully charge a new battery before using.

SAFETY INSPECTION

TROUBLESHOOTING

DON'T	DO
Don't tip or tilt batteries.	Use a carrying strap to remove, move or install a battery.
Don't use ordinary tap water.	ONLY use distilled water to refill.
Don't overfill cells.	Keep the liquid level in the cells at the "split ring" level.
Don't use uneven levels of distilled water in cells.	Maintain the liquid in all cells at the "split ring" level.
Don't tap on clamps or terminals with tools.	Push battery clamps onto terminals. Spread clamps wider if necessary.
Don't mismatch your battery and chargers.	Use ONLY a GEL charger for a GEL or sealed battery and a regular charger for regular batteries.

*NOTE: The following test can also be performed through the controller of the wheelchair along with a remote programmer. Refer to the individual **CONTROLLER MANUAL** supplied with each wheelchair.*

Field Load Test

Old batteries lose their ability to store and release power, due to increased internal resistance. This means that as you try to take power from the battery, some of that power is used up in the process of passing through the battery, resulting in less voltage at the posts. The more power drawn, the lower the voltage available. When this lost voltage drops the output 1.0 volts under load (2.0 for a pair), replace the batteries.

Testing under load is the only way to spot this problem. While special battery load testing equipment is available, it is costly and difficult to transport.

Use a digital voltmeter to check battery charge level at charger connector. It is located on side of wheelchair frame.

NOTE: READ the instructions CAREFULLY before using the digital voltmeter.

1. Ensure that power is OFF.
2. Make sure batteries are fully charged. An extremely discharged battery will exhibit the same symptoms as a bad one.
3. Remove the footrests from the wheelchair and place the front of the wheelchair against a wall, workbench or other stationary object.

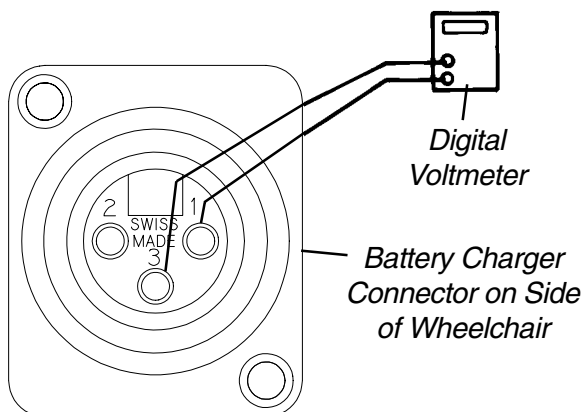

FIGURE 1 - BATTERY CHARGE LEVEL

4. Place the voltmeter leads into the charger plug on the wheelchair. Most digital voltmeters are not affected by polarity, however, analog meters (meters with swinging needles) can be and should be used carefully. A good meter reading should be 25.5 to 26 VDC.
5. Have two (2) individuals (one [1] on each arm) apply as much downward pressure as possible on the arms of the wheelchair.
6. Turn power ON and push joystick forward, trying to drive the wheelchair through the stationary object. This puts a heavy load on the batteries as they try to push through the stationary object. Read meter while motors are straining to determine the voltage under load.

If the voltage drops to less than 23.5 volts from a pair of fully charged batteries while under load, they should be replaced regardless of the unloaded voltages.

Using Hydrometer to Check Battery Cells (Lead Acid) (FIGURE 2)

NOTE: Perform this procedure when a digital voltmeter is not available.

WARNING

NEVER smoke or strike a match near the batteries. If the caps of battery cells are removed, NEVER look directly into them when charging battery.

The use of rubber gloves and safety glasses is recommended when testing the battery cells.

When reading a hydrometer, DO NOT allow any liquid to come in contact with your eyes or skin. It is a form of acid and can cause serious burns, and in some cases, blindness. If you do get battery acid on you, flush the exposed areas with cool water IMMEDIATELY. If the acid comes into contact with eyes or causes serious burns, get medical help IMMEDIATELY.

The battery acid can damage your wheelchair, clothing, and household items. Therefore, take readings cautiously and only in designated areas.

ONLY use distilled water when topping off the battery cells.

WARNING

Most batteries are not sold with instructions. However, warnings are frequently noted on the cell caps. Read them carefully.

1. Remove the battery boxes from the wheelchair. Refer to INSTALLING/REMOVING BATTERY BOXES in PROCEDURE 8 of this manual.
 2. Remove the battery caps from the battery.
 3. Squeeze the air from the hydrometer.
 4. Place the hydrometer into a battery cell.
- NOTE: DO NOT fill hydrometer more than 3/4 full.*
5. Draw up sufficient acid to cover float balls.
 6. Tap lightly to remove air bubbles.
 7. Number of floating balls indicates charge.

NUMBER OF FLOATING BALLS

0	Discharged
1	25% Charged
2	50% Charged
3	75% Charged
4	100% Charged
* 5	Overcharged

* Check charging system.

8. Flush the liquid back into the same cell after reading the float. Repeat this step until all cells have been properly read. A shorted or dead cell can be detected when it is the only cell that doesn't charge.
9. Flush hydrometer in cold running water by allowing the water to rise into the hydrometer as far as possible. Do this several times to guard against burn damage.
10. Replace the battery caps.
11. Install the battery boxes onto the wheelchair. Refer to INSTALLING/REMOVING BATTERY BOXES in PROCEDURE 8 of this manual.

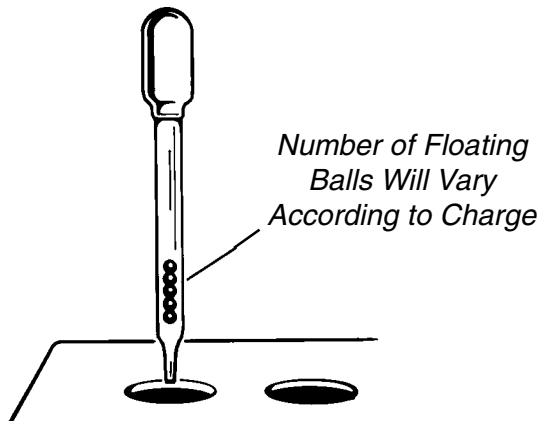

FIGURE 2 - USING HYDROMETER TO CHECK BATTERY CELLS (LEAD ACID)

MOTOR TESTING (FIGURE 3)

WARNING

Invacare recommends that the following procedures be performed by a qualified service technician.

1. On the 4-pin motor connector, locate the two (2) contacts in the red and black housings.
2. Set the digital multimeter to measure ohms.
3. Measure the resistance between the two (2) motor contacts.

NOTE: A normal reading is between 1 and 5 ohms (Ω). A reading of 0 ohms (Ω) or in excess of 15 ohms (Ω) indicates a problem. High readings are generally caused by bad connections and/or damaged brushes. Contact authorized dealer or Invacare.

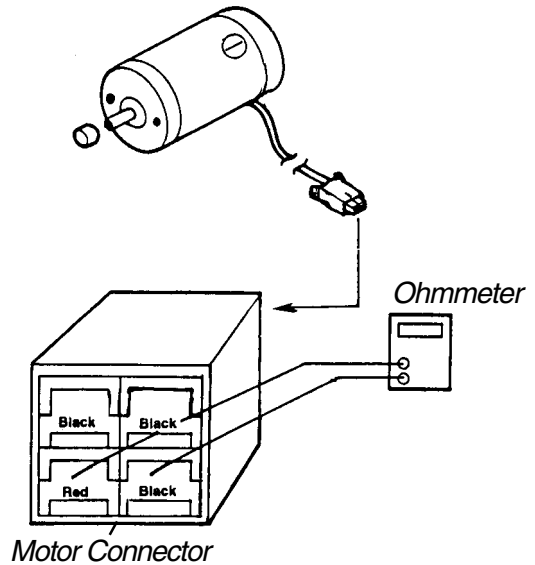

FIGURE 3 - MOTOR TESTING

MOTOR BRUSH INSPECTION (FIGURE 4)

WARNING

Invacare recommends that the following procedures be performed by a qualified service technician.

There are two (2) contact brushes on the motors located under the brush caps on the motor housing. If these caps are hard to remove they are either overtightened or the motor has become very hot. Let motors cool. If caps still cannot be removed, it is recommended that the motor be sent to Invacare Technical Services for inspection/repair.

NOTE: It is very important to note which way the brush comes out of the motor. The brush MUST be placed into the motor exactly the same way to ensure good contact with the commutator.

- Once the motor brush caps have been removed, pull the brushes out of the motor. The end of the brushes should be smooth and shiny and the spring should not be damaged or discolored. If one or both of the brushes are damaged, only the damaged or worn brushes need be replaced. It is very important that any time a brush is replaced, it must be "burned in". This is accomplished by running the motor for one hour in each direction with a half hour break in-between. This should also be done with little or no load on the motor, i.e., put the rear of the wheelchair up on blocks and run the wheelchair. A motor with only one brush replaced will only carry a small percentage of its rated load capacity until the NEW brush is burned in.

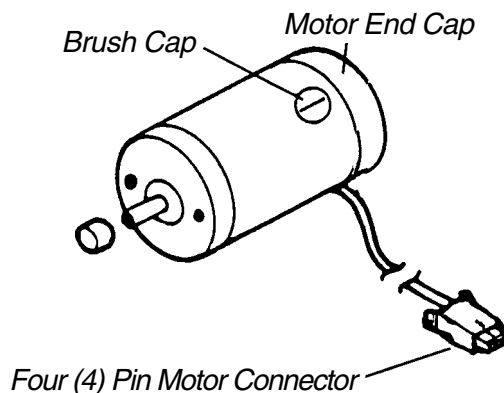

FIGURE 4 - MOTOR BRUSH INSPECTION

MOTOR LOCK TESTING (FIGURE 5)

WARNING

Invacare recommends that the following procedures be performed by a qualified service technician.

- On the four-pin motor connector, locate the side by side connectors in the black housings.
- Set the digital multimeter to read ohms.
- Measure the resistance between the two (2) brake contacts. A normal reading is 100 ohms (Ω). A reading of 0 ohms (Ω) or a very high reading; i.e., MEG ohms or O.L. (out of limit) indicates a shorted brake or an open connection respectively. If either condition exists, it is recommended that the motor be sent to Invacare Technical Service for inspection/repair.

CAUTION

A short circuited brake will damage the brake output section in the controller. DO NOT connect a bad electromechanical brake to a good controller module. A shorted electromechanical brake MUST be replaced.

NOTE: A bad motor can damage the controller module but a bad controller will NOT damage a motor.

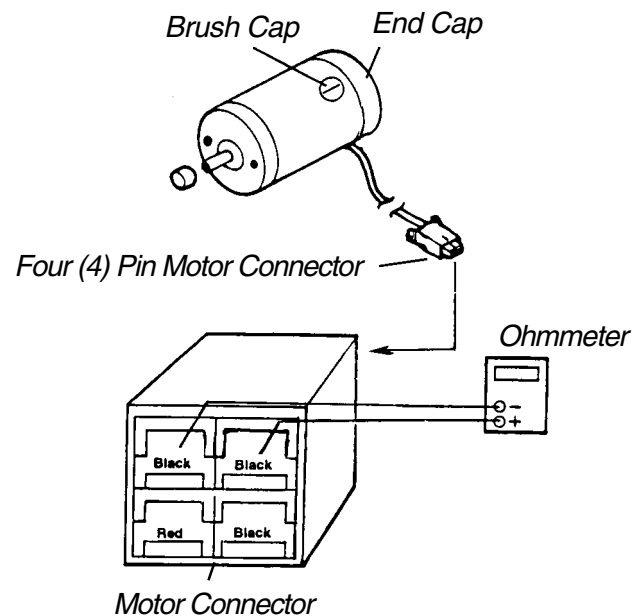

FIGURE 5 - MOTOR LOCK TESTING

This Procedure Includes the Following:
Assembling/Transporting

WARNING
 After ANY adjustments, repair or service and BEFORE use, make sure all attaching hardware is tightened securely - otherwise injury or damage may result.

ASSEMBLING/TRANSPORTING (FIGURE 1)

WARNING
 The following assembly procedure should be performed only by a qualified technician.
 The weight of the wheelchair without the user and batteries is still 94 lbs. Use proper lifting techniques (lift with your legs) to avoid injury. Extreme caution is advised when it is necessary to move an UNOCCUPIED power wheelchair. Invacare recommends using two (2) assistants and making thorough preparations. Make sure to use ONLY secure, non-detachable parts for hand-hold supports.

Unfolding/Folding Wheelchair

WARNING
 Keep hands and fingers clear of moving parts to avoid injury.

UNFOLDING.

1. Push down on the seat rails until the seat rails are positioned in the seat guides.
2. Assemble the wheelchair. Refer to FIGURE 1.

FOLDING.

1. Remove the batteries and footrests/legrests from the wheelchair. Refer to FIGURE 1.
2. Remove the battery tray from the wheelchair. Refer to FIGURE 1.
3. Lift up on the seat rails of the wheelchair.

- **ASSEMBLING** - Install the back assembly*.
 - **TRANSPORTING** - No need to remove the back assembly for transporting.
- *Refer to INSTALLING BACK ASSEMBLY in PROCEDURE 7 of this manual.

- **ASSEMBLING** - Install the battery tray and batteries*.
 - **TRANSPORTING** - Remove the batteries and battery tray*.
- *Refer to INSTALLING/REMOVING BATTERY TRAY and INSTALLING/REMOVING BATTERY BOXES in PROCEDURE 8 of this manual.

- **ASSEMBLING** - Install the electronics*.
 - **TRANSPORTING** - No need to remove the electronics for transporting.
- *Refer to PREPARING MKIV JOYSTICK FOR USE in PROCEDURE 9 of this manual.

- **ASSEMBLING** - Install the footrests/legrests*.
 - **TRANSPORTING** - Remove the footrests/legrests*.
- *Refer to INSTALLING/REMOVING FOOTRESTS or INSTALLING/REMOVING ELEVATING LEGRESTS in PROCEDURE 4 of this manual.

- **ASSEMBLING** - Install the anti-tippers*.
 - **TRANSPORTING** - Remove the anti-tippers*.
- *Refer to INSTALLING/REMOVING ANTI-TIPPERS in PROCEDURE 12 of this manual.

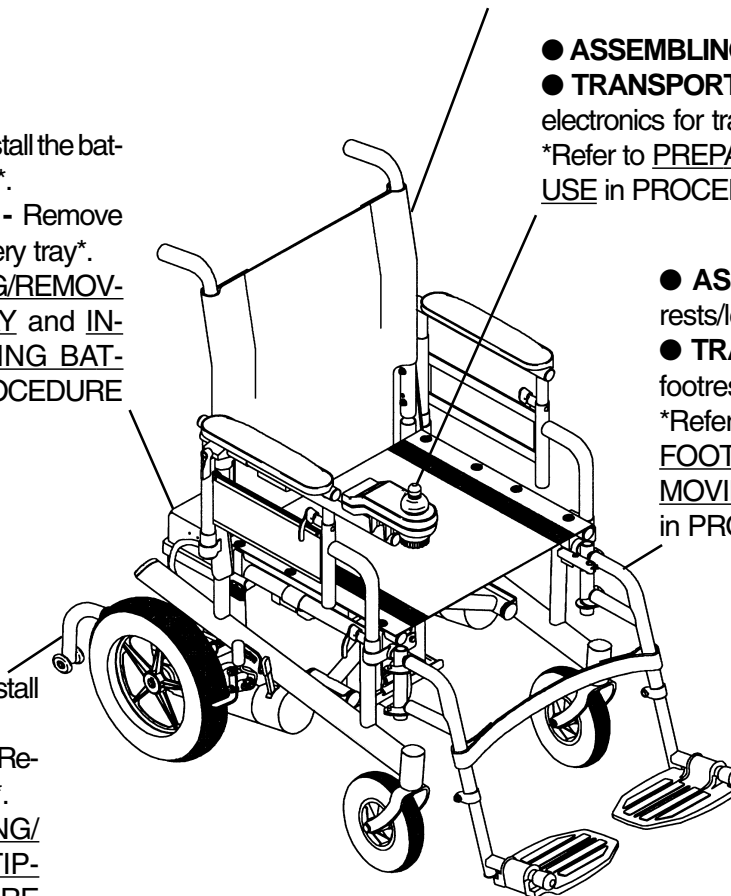

FIGURE 1 - ASSEMBLING/TRANSPORTING

This Procedure Includes the Following:
Installing/Removing Footrests
Adjusting Footrest Height
Replacing Heel Loops
Installing/Removing Elevating Legrests
Raising/Lowering Elevating Legrests and/or
Adjusting Calfpads
Adjusting/Replacing Telescoping Front
Rigging Support

WARNING

After ANY adjustments, repair or service and BEFORE use, make sure all attaching hardware is tightened securely - otherwise injury or damage may result.

INSTALLING/REMOVING FOOTRESTS (FIGURE 1)

Installing

1. Turn the footrest to the side (open footplate is perpendicular to wheelchair) and position the mounting holes in the footrest hinge plates with the hinge pins on the wheelchair frame.
 2. Install the footrest hinge plates onto the hinge pins on the wheelchair frame.
 3. Push the footrest towards the inside of the wheelchair until it locks into place.
- NOTE: The footplate will be on the inside of the wheelchair when locked in place.*
4. Repeat STEPS 1-3 for opposite side of wheelchair.

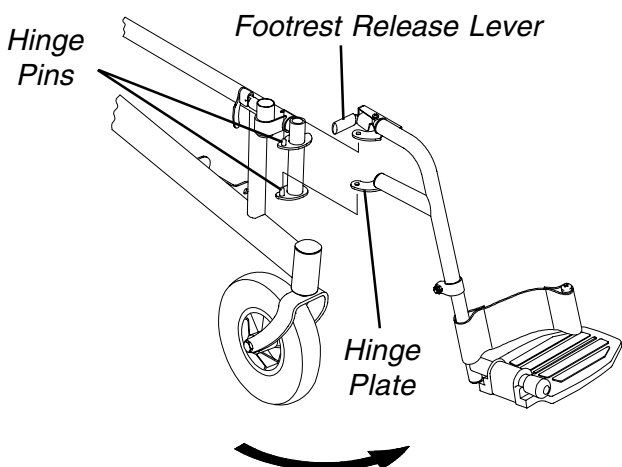

FIGURE 1 - INSTALLING/REMOVING FOOTRESTS

Removing

1. Push the footrest release lever inward and rotate the footrest outward.
2. Lift up on the footrest and remove from the wheelchair.
3. Repeat STEPS 1-2 for the opposite side of the wheelchair.

ADJUSTING FOOTREST HEIGHT

All Footrests Except Model P93M Footrests (FIGURE 2)

1. Remove any accessory from the footrest(s).
 2. Remove the footrest from the wheelchair. Refer to INSTALLING/REMOVING FOOTRESTS in this procedure of the manual.
- NOTE: Lay the footrest on a flat surface to simplify this procedure.*
3. Remove the hex bolt, coved washers and locknut that secure the lower footrest to the footrest support.
 4. Reposition the lower footrest to the desired height.
 5. Reinstall the hex bolt, coved washers and locknut that secure the lower footrest to the footrest support and tighten securely.
 6. Repeat STEPS 1-5 for the opposite side of the wheelchair footrest, if necessary.
 7. Reinstall the footrest(s) onto the wheelchair. Refer to INSTALLING/REMOVING FOOTRESTS in this procedure of the manual.
 8. Reinstall any accessory onto the footrest(s).

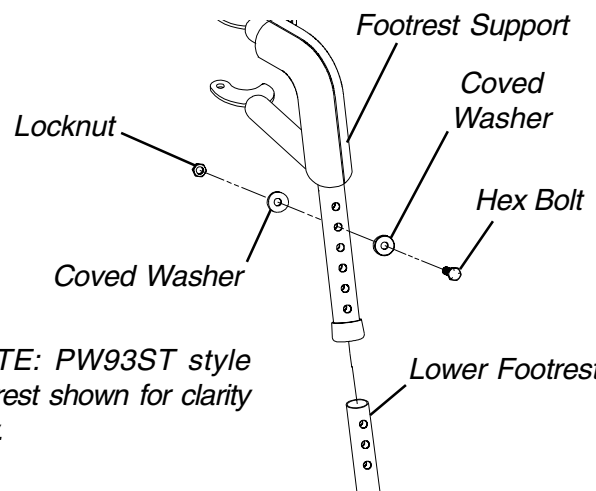

NOTE: PW93ST style footrest shown for clarity only.

FIGURE 2 - ADJUSTING FOOTREST HEIGHT - ALL FOOTRESTS EXCEPT MODEL P93M FOOTRESTS

P93M Model Footrests (FIGURE 3)

1. Loosen, but do not remove the lug bolt and locknut that secure the lower footrest to the footrest support.
2. Reposition the lower footrest to the desired height.
3. Securely tighten the lug bolt and locknut that secure the lower footrest to the footrest support.
4. Repeat STEPS 1-3 for the opposite side of the wheelchair footrest, if necessary.

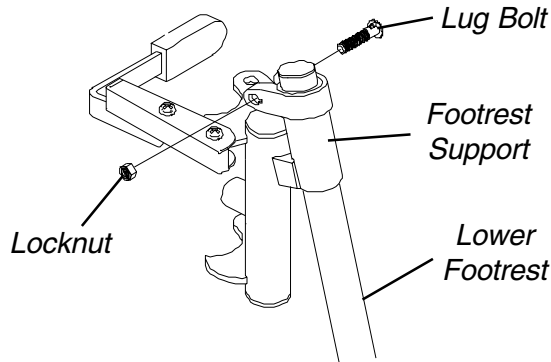

FIGURE 3 - ADJUSTING FOOTREST HEIGHT - P93M MODEL FOOTRESTS

REPLACING HEEL LOOPS (FIGURE 4)

1. Note the position the hex bolt, covered washers and locknut for reinstallation.
2. Remove the hex bolt, covered washers and locknut that secure the lower footrest to the footrest support.
3. Remove the lower footrest.
4. Remove the phillips bolt and locknut that secure the existing heel loop to the lower footrest.
5. Slide the existing heel loop off the lower footrest.
6. Replace heel loop.
7. Reverse STEPS 1-6 to reassemble.

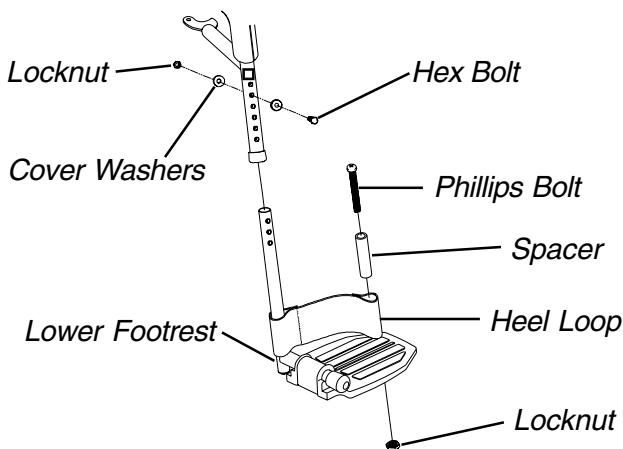

FIGURE 4 - REPLACING HEEL LOOPS

NOTE: When securing the heel loop to the lower footrest, tighten the phillips screw and locknut until the spacer is secure.

INSTALLING/REMOVING ELEVATING LEGRESTS (FIGURE 5)

Installing

1. Turn the legrest to the side (open footplate is perpendicular to wheelchair) and position the mounting holes in the legrest hinge plates with the hinge pins on the wheelchair frame.
2. Install the legrest hinge plates onto the hinge pins on the wheelchair frame.
3. Rotate legrest toward the inside of the wheelchair until it locks in place.

NOTE: The footplate will be on the inside of the wheelchair when locked in place.

4. Repeat STEPS 1-3 for the opposite legrest.
5. After seated in wheelchair, adjust footplate to correct height by loosening the nut and sliding the lower footrest assembly up or down until desired height is achieved.

Removing

1. Push the legrest release handle toward the inside of the wheelchair (facing the front of the wheelchair) and swing the legrest to the outside of the wheelchair.
2. Lift up on the legrest and remove from the wheelchair.
3. Repeat STEPS 1-2 for the opposite side of the wheelchair.

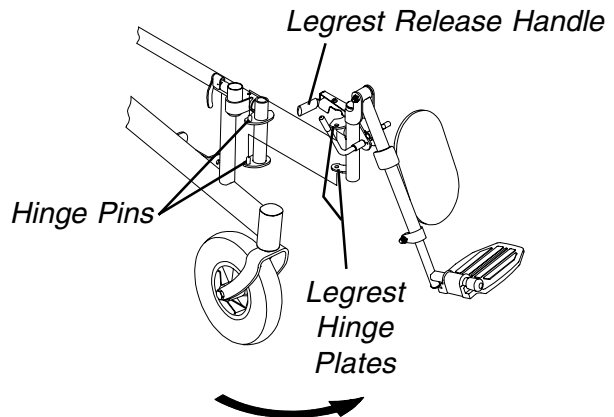

FIGURE 5- INSTALLING/REMOVING ELEVATING LEGRESTS

RAISING/LOWERING ELEVATING LEGRESTS AND/OR ADJUSTING CALFPADS (FIGURE 6)

Raising/Lowering Elevating Legrests

1. Perform one (1) of the following:
 - RAISING - Pull back on the release lever until the leg is at the desired height.
 - LOWERING - Support leg with one (1) hand and push release lever downward with other hand.

Adjusting Calfpads

1. Turn the calfpad towards the outside of the wheelchair.
2. Slide calfpad up or down until the desired position is obtained.

NOTE: If one (1) of the top two (2) calfpad adjustment positions is being used, the legrest will need to be raised to avoid interference with the front stabilizers while going over obstacles or going up and down ramps. Refer to RAISING/LOWERING ELEVATING LEGRESTS in this procedure of the manual.

3. Turn the calfpad towards the inside of the wheelchair.

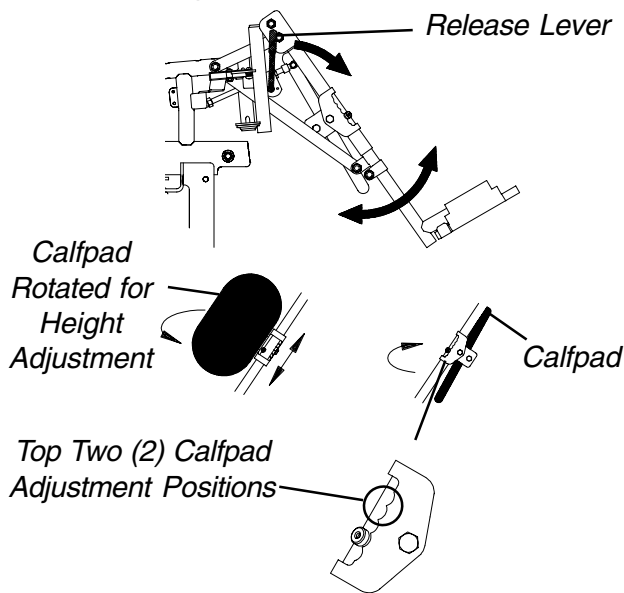

FIGURE 6- RAISING/LOWERING ELEVATING LEGRESTS AND/OR ADJUSTING CALFPADS

ADJUSTING/REPLACING TELESCOPING FRONT RIGGING SUPPORT (FIGURE 7)

1. Lift up on the crossbraces until they release from the H-blocks on the wheelchair frame.
2. Remove the phillips bolt and locknut that secure the H-block to the wheelchair frame.

3. Remove the two (2) locknuts and socket bolts that secure the support assembly to the wheelchair.

Adjusting

1. Position the support assembly to the desired depth.

NOTE: The two (2) support assemblies may be positioned at different depths depending on the need of the user.
2. Insert the front socket bolt into the wheelchair frame and the mounting hole in the telescoping front rigging support determined in STEP 1 and securely tighten with the locknut.
3. Insert the rear socket bolt through the wheelchair frame and the telescoping front rigging support and securely tighten with the locknut.
4. Resecure the H-block to the wheelchair with the phillips bolt and locknut.
5. Snap the crossbraces into the H-blocks. Wiggle the crossbraces to make sure they are secured in H-blocks.

Replacing

NOTE: Observe the position of the current support assembly before removal to ensure correct position of new support assembly.

1. Remove existing support assembly from wheelchair.
2. Adjust the telescoping front rigging support. Refer to ADJUSTING TELESCOPING FRONT RIGGING SUPPORT in this procedure of the manual.

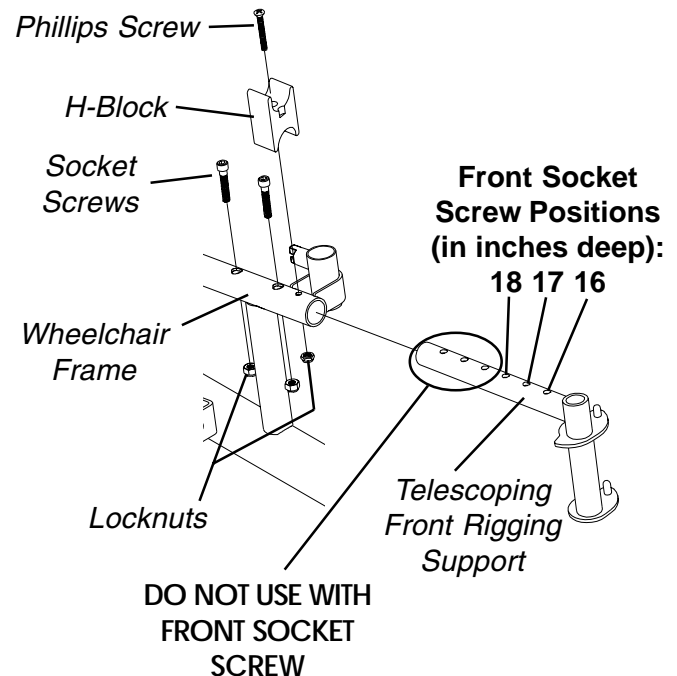

FIGURE 7 - ADJUSTING/REPLACING TELESCOPING FRONT RIGGING SUPPORT

ARMS

This Procedure Includes the Following:
Adjusting Armrest Height, Removing or Replacing Armrests
Installing/Removing Flip Back Armrests - Non-Recliner Wheelchairs Built After 10/2000 ONLY
Adjusting Flip Back Armrests - Non-Recliner Wheelchairs Built After 10/2000 ONLY

WARNING
 After ANY adjustments, repair or service and BEFORE use, make sure all attaching hardware is tightened securely - otherwise injury or damage may result.

ADJUSTING ARMREST HEIGHT, REMOVING OR REPLACING ARMRESTS (FIGURE 1)

WARNING
 Make sure the locking mechanism is secured before using the wheelchair.

Adjusting Armrest Height

1. Unlock the armrest by flipping the height adjustment lever on the top front of the arm to the UP (HORIZONTAL) position.
2. Adjust armrest to desired height.

NOTE: Height adjustment lever MUST be in the unlocked position when placing armrest into the arm assembly.

3. Lock the armrest by pressing the height adjustment lever into the DOWN (VERTICAL) position when the desired height is achieved.

Removing Armrests

1. Unlock the armrest by flipping the armrest release lever located on the side rail to the UP (HORIZONTAL) position.
2. Remove the armrest from the wheelchair.

Replacing Armrests

NOTE: Armrest release lever MUST be in the unlocked position when placing armrest into the arm sockets.

1. Lock the armrest by pressing the armrest release lever into the DOWN (VERTICAL) position.

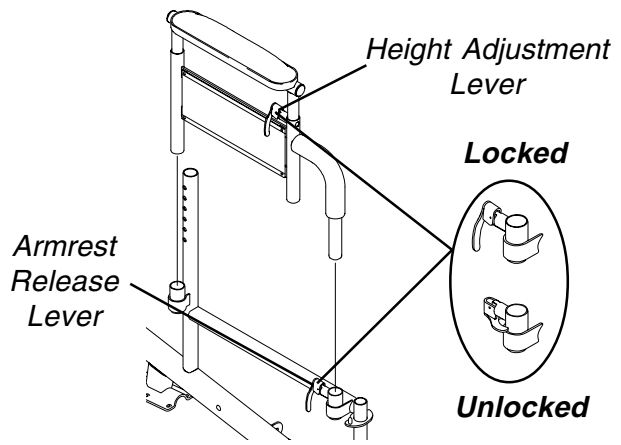

FIGURE 1 - ADJUSTING ARMREST HEIGHT, REMOVING OR REPLACING ARMRESTS

INSTALLING/REMOVING FLIP BACK ARMRESTS - NON-RECLINER WHEELCHAIRS BUILT AFTER 10/2000 ONLY (FIGURE 2)

WARNING
 Make sure the flip back armrest release and height adjustment levers are in the locked position before using the wheelchair.

NOTE: Flip back armrest release lever must be in unlocked position when placing armrest into the arm sockets.

Installing

1. Slide the flip back armrest into the arm sockets on the wheelchair frame.
2. Install the quick release pin through the rear arm socket and flip back armrest.
3. Lock flip back armrest by pressing flip back armrest release lever into the DOWN (VERTICAL) position.
4. Lift up on flip back armrest to make sure the armrest is locked in place.
5. Repeat STEPS 1-4 for opposite flip back armrest.

Removing

1. Unlock flip back armrest by pulling flip back armrest release lever into the UP (HORIZONTAL) position.
2. Remove the quick release pin that secures the flip back armrest to the wheelchair frame.
3. Pull up on the flip back armrest and remove the armrest from the arm sockets.
4. Repeat STEPS 1-3 for the opposite flip back armrest, if necessary.

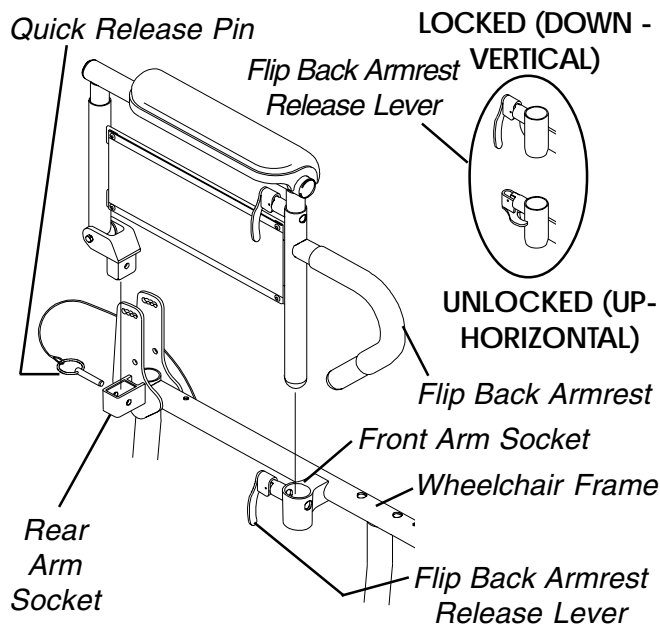

FIGURE 2 - INSTALLING/REMOVING FLIP BACK ARMRESTS - NON-RECLINER WHEELCHAIRS BUILT AFTER 10/2000 ONLY

ADJUSTING FLIP BACK ARMRESTS - NON-RECLINER WHEELCHAIRS BUILT AFTER 10/2000 ONLY (FIGURE 3)

Positioning Flip Back Armrests for User Transfer

1. Unlock the flip back armrest by pulling the armrest release lever into the UP (HORIZONTAL) position.
2. Pull up on the flip back armrest and remove the armrest from the front arm socket.
3. Continue to pull up on the flip back armrest until the armrest is out of the way.
4. Repeat STEPS 1-3 for opposite flip back armrest, if necessary.

Positioning Flip Back Armrests for Use

1. Make sure the flip back armrest release lever is in the UP (HORIZONTAL) position.
2. Install the flip back armrest into the front arm socket.

3. Lock flip back armrest by pressing flip back armrest release lever into the DOWN (VERTICAL) position.
4. Lift up on flip back armrest to make sure the armrest is locked in place.
5. Repeat STEPS 1-4 for opposite flip back armrest, if necessary.

Adjusting

1. Unlock top of flip back armrest by pulling height adjustment lever into the UP (HORIZONTAL) position.
2. Adjust top of the flip back armrest to the desired height.
3. Lock top of flip back armrest by pushing height adjustment lever into the DOWN (VERTICAL) position.
4. Lift up on flip back armrest to make sure the armrest is locked in place.
5. Repeat STEPS 1-4 for opposite flip back armrest, if necessary.

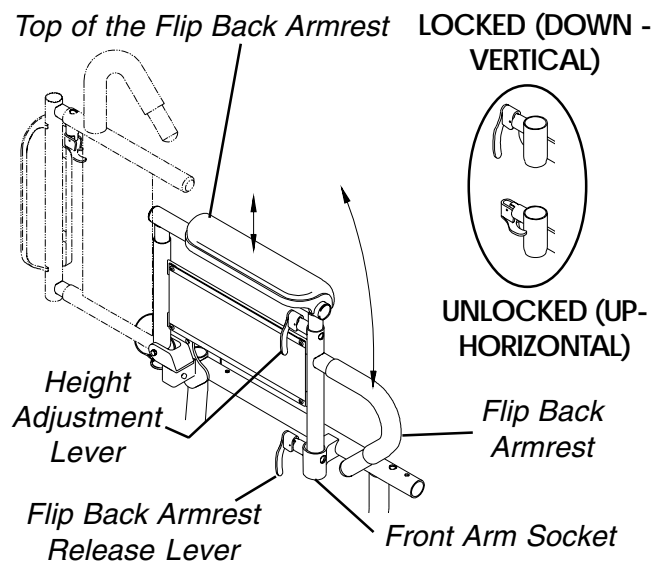

FIGURE 3- ADJUSTING FLIP BACK ARMRESTS - NON-RECLINER WHEELCHAIRS BUILT AFTER 10/2000 ONLY

This Procedure Includes the Following:
 Replacing Seat Upholstery
 Replacing Seat Positioning Strap
 Replacing Back Upholstery

WARNING
 After ANY adjustments, repair or service and BEFORE use, make sure all attaching hardware is tightened securely - otherwise injury or damage may result.

REPLACING SEAT UPHOLSTERY (FIGURE 1)

1. Remove the eight (8) phillips screws that secure the existing seat upholstery to the crossbraces.
2. Remove existing seat upholstery from the crossbraces.
3. Line up mounting holes in new seat upholstery with mounting holes in the crossbraces.
4. Securely tighten with existing phillips screws.

NOTE: Clean upholstery with warm DAMP cloth and mild detergent to remove superficial soil.

WARNING
 Laundering or moisture will reduce flame retardation of the upholstery.

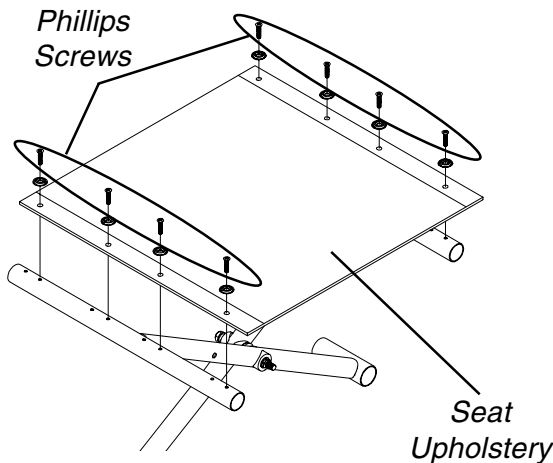

FIGURE 1 - REPLACING SEAT UPHOLSTERY

REPLACING SEAT POSITIONING STRAP (FIGURE 2)

1. Remove the seat cushion from the seat upholstery.
2. Remove the two (2) rear phillips screws and washers that secure the seat upholstery and seat positioning strap to the crossbraces.
3. Remove the two (2) halves of the seat positioning strap from the crossbraces.
4. Reposition the two (2) new seat positioning strap halves between the seat upholstery and crossbraces.
5. Reinstall the rear phillips screws and washers that secure the seat upholstery and seat positioning strap to the crossbraces.

NOTE: Washer is positioned on top of seat upholstery.

6. Reinstall the seat cushion onto the seat upholstery.

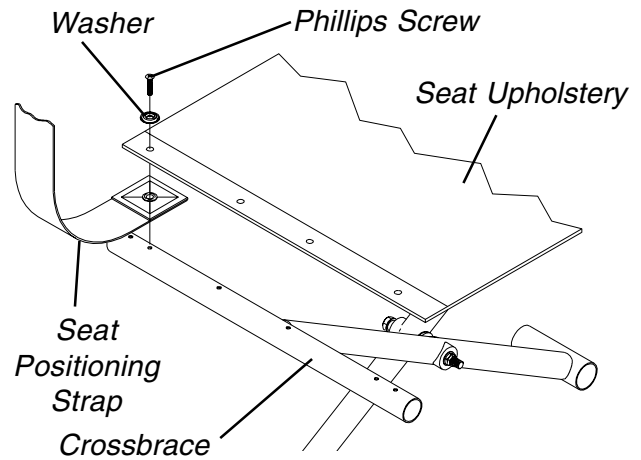

FIGURE 2 - REPLACING SEAT POSITIONING STRAP

REPLACING BACK UPHOLSTERY

Wheelchairs Before 10/2000 (FIGURE 3)

1. Remove one (1) armrest from the wheelchair.
2. On the side of the wheelchair that the armrest was removed, remove the hex bolt and locknut that secures the spreader bar to the back cane.
3. Cut the tie-wraps that secure the bottom of the existing back upholstery to the wheelchair frame.
4. Remove the two (2) phillips screws and washers that secure the existing back upholstery to the back canes.
5. On the side of the wheelchair that the armrest was removed, remove the two (2) hex bolts, washers and locknuts that secure the back cane to the mounting plates.

NOTE: The insert in the back cane will slide out of the back cane.

NOTE: Remove only ONE (1) back cane from the wheelchair.

- Slide the back cane out of the spreader bar and the existing back upholstery.

NOTE: Make sure the clamp on the spreader bar is loose before removing the back cane from the wheelchair, otherwise the back cane can be scratched.

- Pull the existing back upholstery up and over the mounted back cane.
- Install the new back upholstery over the mounted back cane.
- Slide the loose back cane through the new back upholstery and spreader bar.
- Install the insert into the back cane.

NOTE: To keep the insert lined up for reinstallation onto the mounting plate, install one (1) of the hex bolts through the back cane from the inside of the wheelchair to hold the insert in place.

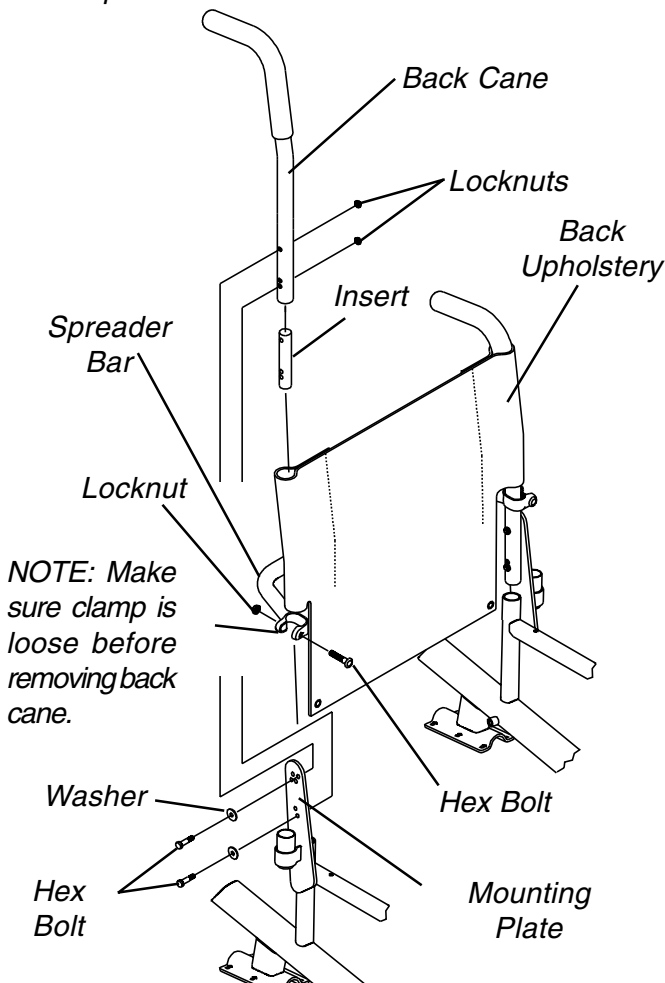

FIGURE 3- REPLACING BACK UPHOLSTERY - WHEELCHAIRS BEFORE 10/2000

- Slide the other hex bolt and washer through the mounting plate, insert and back cane and loosely tighten with a locknut.

*NOTE: Refer to the opposite back cane for the correct hex bolt mounting positions to ensure the desired back angle, or refer to **CHANGING BACK ANGLE** in this procedure of the manual.*

- Remove the hex bolt that was holding the insert in place and install the through the mounting plate, insert and back cane and secure with the other locknut.

WARNING

The back canes **MUST** be fastened securely to the mounting plates **BEFORE** using the wheelchair. Use Loctite® 242 and torque to 75-inch pounds.

- Secure the back cane to mounting plate with the two (2) hex bolts, washers and locknuts. Use Loctite 242 and torque to 75-inch pounds.
- Secure the top of the new back upholstery to the back canes with the two (2) existing phillips screws.
- Secure the bottom of the existing back upholstery to the wheelchair frame with new tie wraps.

NOTE: Clean upholstery with warm DAMP cloth and mild detergent to remove superficial soil.

WARNING

Laundering or moisture will reduce flame retardation of the upholstery.

NOTE: When replacing the back upholstery, follow these guidelines for spreader bar height:

BACK HEIGHT (in inches):	16-17	18-19	20
✦ SPREADER BAR HEIGHT (in inches):	5	7	9

✦ Height of Spreader Bar from Bottom of Back Canes to Top of Spreader Bar Clamp.

- Make sure the spreader bar is at the correct height for the corresponding back height.
- Reinstall the bolt and locknut that secures the spreader bar to the back cane and torque to 60-inch pounds.
- Reinstall the armrest onto the wheelchair.

**Wheelchairs Built After 10/2000
(FIGURE 4)**

1. Flip the armrests up and out of the way. Refer to USING/ADJUSTING FLIP BACK ARMRESTS in PROCEDURE 5 of this manual.
2. Cut the tie-wraps that secure the bottom of the existing back upholstery to the wheelchair frame.
3. Remove the two (2) phillips screws and washers that secure the existing back upholstery to the back canes.
4. Remove the two (2) hex bolts, washers and locknuts that secure one (1) back cane to the wheelchair frame.

NOTE: It is necessary to remove only one (1) back cane to replace the back upholstery.

5. Pull the loose back cane out of the existing back upholstery.
6. Pull the existing back upholstery up and over the mounted back cane.
7. Install new back upholstery over mounted back cane.
8. Slide the loose top half of the back cane through the new back upholstery.
9. Using the mounted back cane as a guide, reinstall the two (2) hex bolts that secure the top half of the back cane to the bottom half of the back cane.

NOTE: Make sure the back canes are mounted to the same height.

WARNING

The top and bottom half of the back canes **MUST** be tightened securely together **BEFORE** using the wheelchair, otherwise injury or damage may occur. Use Loctite 242 on the hex bolts and torque to 75-inch pounds.

10. Use Loctite 242 on the hex bolts and torque into the back canes to 75-inch pounds.
11. While holding the hex bolt, reinstall the locknut and torque to 75-inch pounds.
12. Repeat STEP 11 for the other hex bolt and locknut.
13. Securely tighten the new back upholstery to the back canes with the two (2) phillips screws and washers.
14. Secure the bottom of the new back upholstery to the wheelchair frame with tie-wraps.

NOTE: Clean upholstery with warm DAMP cloth and mild detergent to remove superficial soil.

WARNING

Laundering or moisture will reduce flame retardation of the upholstery.

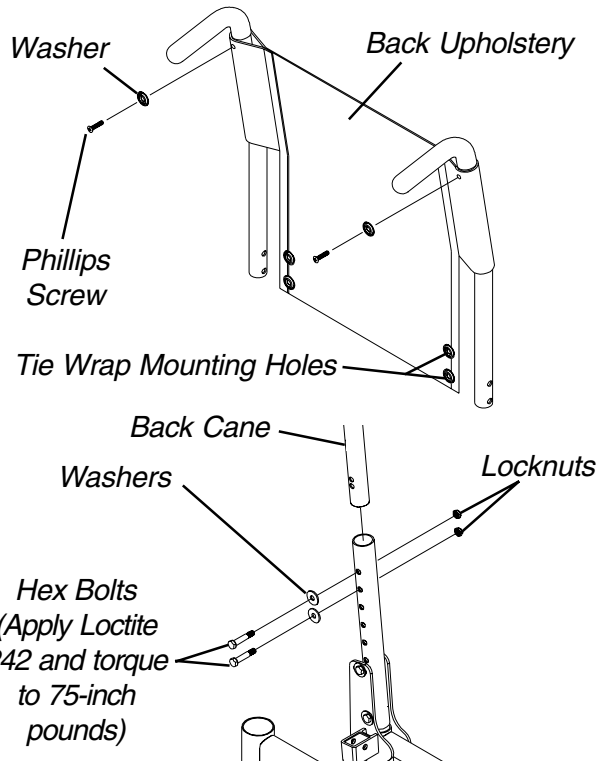

**FIGURE 4 - REPLACING BACK UPHOLSTERY -
WHEELCHAIRS BUILT AFTER 10/2000**

This Procedure Includes the Following:
Adjusting Seat Width
Adjusting Seat Depth
Installing Back Assembly - Wheelchairs Before 10/2000 ONLY
Changing Back Height
Changing Back Angle
Replacing Back Canes - Wheelchairs Built After 10/2000 ONLY

WARNING

The following procedures should only be performed by a qualified technician.

After ANY adjustments, repair or service and BEFORE use, make sure all attaching hardware is tightened securely - otherwise injury or damage may result.

**ADJUSTING SEAT WIDTH
(FIGURE 1)**

1. Remove the battery boxes and battery tray from the wheelchair. Refer to INSTALLING/REMOVING BATTERY BOXES and INSTALLING/REMOVING BATTERY TRAY in PROCEDURE 8 of this manual.

2. Remove the existing back and seat upholstery from the wheelchair. Refer to REPLACING BACK UPHOLSTERY and REPLACING SEAT UPHOLSTERY in PROCEDURE 6 of this manual.

NOTE: If adjusting the seat width of the wheelchair, the back and seat upholstery MUST be changed as well.

3. Remove the hex screws and locknuts that secure the two (2) pivot links to the wheelchair frame and crossbraces. Refer to the following chart to determine if new pivot links will be needed:

PIVOT LINK SEAT WIDTH RANGE (in inches)
14-15, 16-18 and 19-20

4. Remove the black dust covers from the bottom of the crossbraces.

NOTE: Note position of the tie wraps that secure the wiring harness to the crossbraces.

5. Cut the tie wraps that secure the wiring harness to the crossbrace.

6. Remove the hex screws, washers and locknuts that secure the bottom of the two (2) crossbraces to the wheelchair frame.

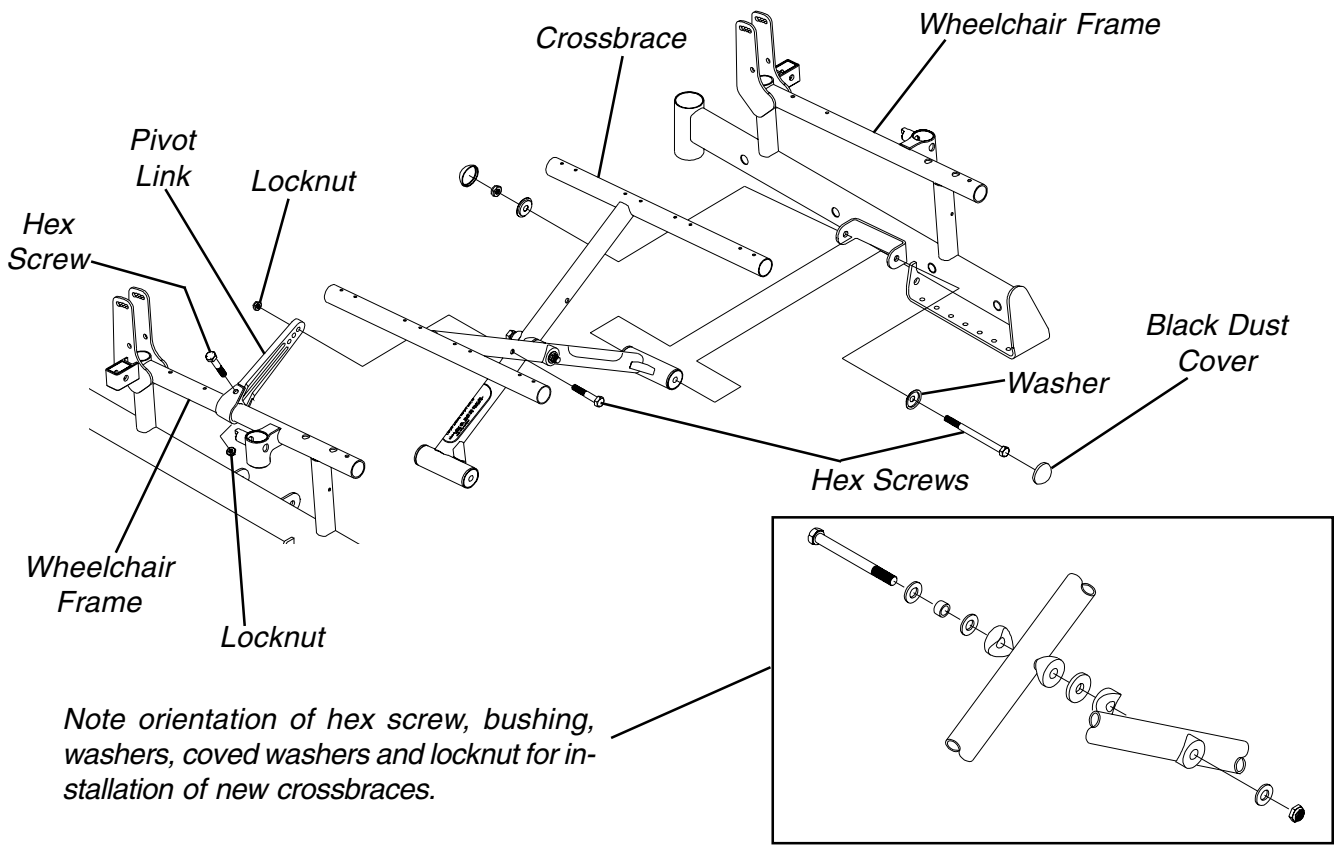

FIGURE 1 - ADJUSTING SEAT WIDTH

FRAME

- Remove the hex screw, coved spacers, washers and locknut that secure the two (2) existing crossbraces together.

NOTE: Note coved spacer, washer and locknut order for reinstallation.

- Assemble the two (2) new crossbraces together. Refer to FIGURE 1 for hardware orientation.
- Reinstall the hex screws, washers and locknuts that secure the bottom of the two (2) new crossbraces to the wheelchair frame and tighten.
- Reinstall the hex screws and locknuts that secure the pivot links to the wheelchair frame and crossbraces and tighten.
- Secure wiring harness to the new crossbraces with tie wraps.
- Reinstall the black dust covers onto the bottom of the crossbraces.
- Install the new back and seat upholstery onto the wheelchair. Refer to REPLACING BACK UPHOLSTERY and REPLACING SEAT UPHOLSTERY in PROCEDURE 6 of this manual.
- Reinstall the battery tray and battery boxes/batteries onto the wheelchair. Refer to INSTALLING/REMOVING BATTERY TRAY and INSTALLING/REMOVING BATTERY BOXES in PROCEDURE 8 of this manual.

ADJUSTING SEAT DEPTH (FIGURE 2)

- Remove the existing seat upholstery from the wheelchair. Refer to REPLACING SEAT UPHOLSTERY in PROCEDURE 6 of this manual.

NOTE: If adjusting seat depth of the wheelchair, the seat upholstery MUST be changed as well.

- Remove the two (2) plug buttons from the ends of the crossbraces that are towards the front of the wheelchair.

NOTE: The two (2) plug buttons will be used in the ends of the seat extensions.

- Install the two (2) seat extension tubes into the ends on the crossbraces. Line up the **second** mounting hole from the **rear** of the seat extension tube with the front mounting hole in the crossbrace.
- Install the new seat upholstery onto the wheelchair. Make sure to line up the mounting holes in the seat extension tubes with the new seat upholstery. Refer to REPLACING SEAT UPHOLSTERY in PROCEDURE 6 of this manual.

- Install plug buttons into the ends of the seat extension tubes.

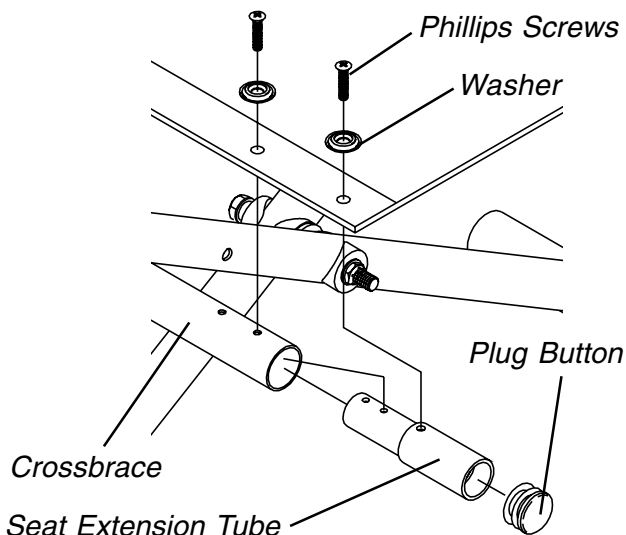

FIGURE 2 - ADJUSTING SEAT DEPTH

INSTALLING BACK ASSEMBLY - WHEELCHAIRS BUILT BEFORE 10/2000 ONLY (FIGURE 3)

- Position the back assembly on the seat upholstery with the back canes and spreader bar facing UP.
- Locate the two (2) back canes between the two (2) back cane mounting plates.

NOTE: The back canes will fit tightly between the back cane mounting plates. Some marring of NON-VISIBLE portions of the back canes and back cane mounting plates is possible.

- Slide the two (2) inserts into the back canes. Make sure the mounting holes in the inserts and the back canes line up.
- Determine the mounting holes in the back cane mounting plates for the necessary back angle. Refer to CHANGING BACK ANGLE in this procedure of the manual.
- Install the two (2) **LOWER** hex bolts and washers through the back cane mounting plate, back cane and insert at the position determined in STEP 4.
- Secure the hardware in STEP 5 with two (2) locknuts. Use Loctite 242 and tighten to 75-inch pounds.
- Flip the back assembly to the UP position as shown in FIGURE 3.

- Install the two (2) **UPPER** hex bolts and washers through the back cane mounting plate, back cane and insert at the position determined in STEP 4.

WARNING

The back canes **MUST** be fastened securely to the mounting plates **BEFORE** using the wheelchair. Use Loctite 242 and torque to 75-inch pounds.

- Secure the hardware in STEP 8 with two (2) locknuts. Use Loctite 242 and tighten to 75-inch pounds.

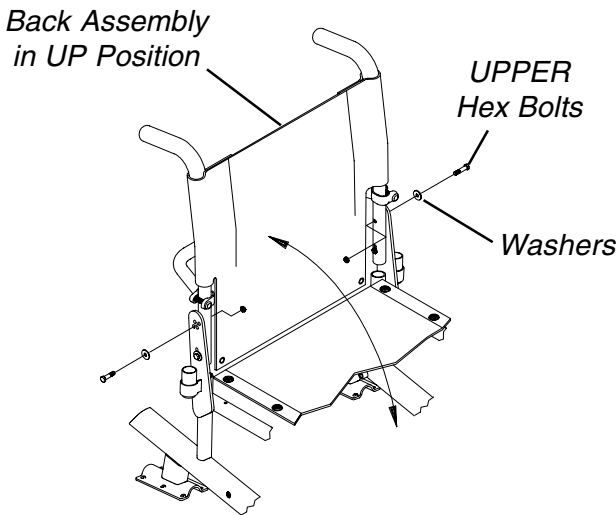
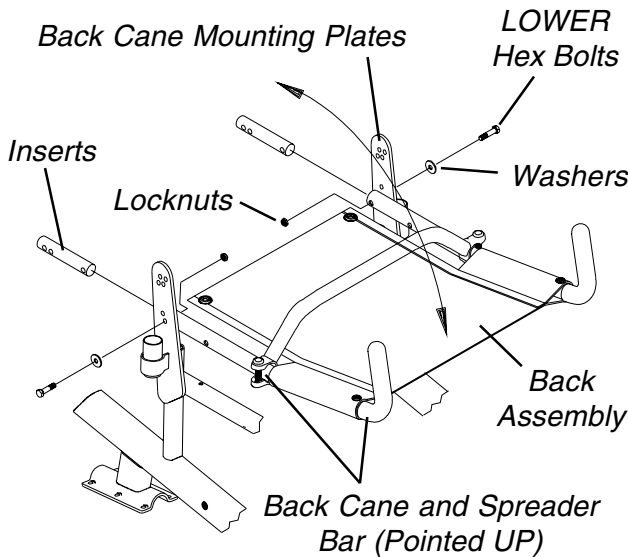

FIGURE 3 - INSTALLING BACK ASSEMBLY - WHEELCHAIRS BUILT BEFORE 10/2000 ONLY

CHANGING BACK HEIGHT

Wheelchairs Built Before 10/2000 (FIGURE 4)

NOTE: If changing the back height, new back upholstery may be needed as well. Refer to the following chart to determine if new back upholstery is needed:

BACK UPHOLSTERY HEIGHT RANGES		
16-17-INCHES	OR	18-20-INCHES

If the back height required is within the range of the original back height, only new back canes will be needed.

If the back height required is **NOT** within the range of the original back height, new back upholstery and new back canes will be needed.

NOTE: Existing hardware and inserts will be reused.

- Remove the armrests from the wheelchair.

NOTE: Note position of the four (4) hex screws that secure the back canes to the wheelchair frame to ensure proper back angle during installation of new back canes.

- Cut the tie wraps that secure the bottom of the back upholstery to the wheelchair frame.
- Remove the four (4) hex bolts that secure the existing back canes to the seat frame.
- Remove the back canes, back upholstery and spreader bar from the wheelchair.
- Remove the inserts from the existing back canes.
- Remove the two (2) phillips screws that secure the back upholstery to the back canes.
- Loosen, but do not remove the two (2) hex bolts and locknuts securing the spreader bar to the existing back canes.

NOTE: Make sure the clamps on the spreader bar are loose before removing the back canes from the spreader bar, otherwise the back canes can be scratched.

- Slide the existing back canes out of the back upholstery and spreader bar.
- Slide the new back canes through the existing/new back upholstery and spreader bar.
- Loosely tighten the hex bolts that secure the spreader bar to the new back canes.
- Slide the inserts into the bottom of the new back canes.
- Line up the mounting holes of the inserts with the mounting holes in the back canes.

NOTE: To keep the inserts lined up for reinstallation onto the wheelchair, install one (1) of the hex bolts through the back cane from the inside of the wheelchair to hold the insert in place.

13. Line up the mounting holes in the back canes with the mounting holes in the mounting plate.

NOTE: If a reference for the proper mounting holes for the back angle required is needed, or if changing the original back angle, refer to CHANGING BACK ANGLE in this procedure of the manual.

14. Slide the other two (2) hex bolts through the mounting plate, insert a back cane and loosely tighten with two (2) of the locknuts.

15. Remove the two (2) hex bolts that were holding the inserts in place and install through the mounting plates, inserts and back canes and secure with the other locknuts.

WARNING

The back canes **MUST** be fastened securely to the seat frame **BEFORE** using the wheelchair. Use Loctite 242 and torque to 75-inch pounds.

16. Secure the two (2) new back canes to the wheelchair frame with the existing four (4) hex bolts, washers and locknuts. Use Loctite 242 and torque to 75-inch pounds.

17. Secure the top of the existing/new back upholstery to the back canes with the two (2) existing phillips screws.

18. Secure the bottom of the existing/new back upholstery to the wheelchair frame with new tie-wraps.

NOTE: Clean upholstery with warm DAMP cloth and mild detergent to remove superficial soil.

WARNING

Laundering or moisture will reduce flame retardation of the upholstery.

NOTE: When replacing the back assembly or changing back height, follow these guidelines for spreader bar height:

BACK HEIGHT (in inches):	16-17	18-19	20
★ SPREADER BAR HEIGHT (in inches):	5	7	9

★ Height of Spreader Bar from Bottom of Back Canes to Top of Spreader Bar Clamp.

19. Reposition the spreader bar at the correct height for the corresponding back height and torque the mounting hardware to 60-inch pounds.

20. Reinstall the armrests onto the wheelchair.

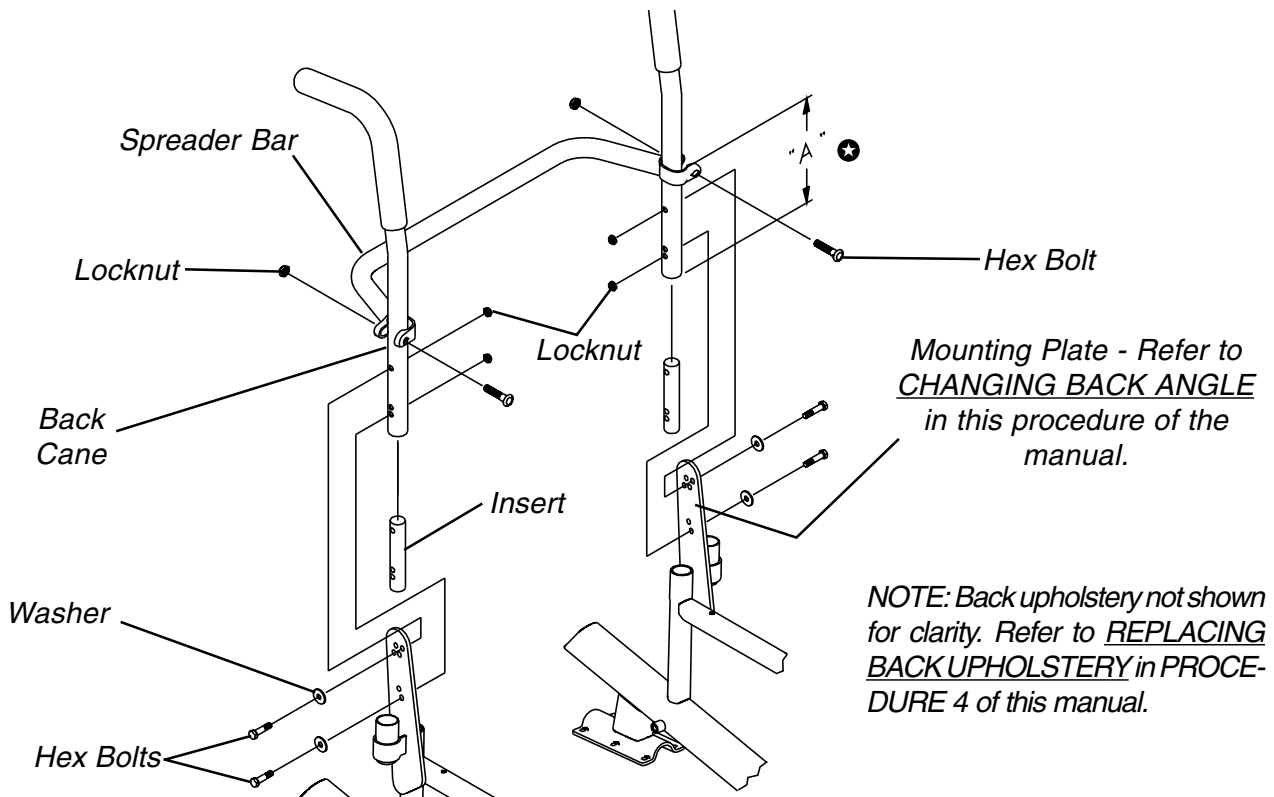

FIGURE 4 - CHANGING BACK HEIGHT - WHEELCHAIRS BUILT BEFORE 10/2000

Wheelchairs Built After 10/2000 (FIGURE 5)

1. Remove the two (2) hex bolts, washers and locknuts that secure the top half of the back cane to the bottom half of the back cane.
2. Reposition the back cane to one (1) of five (5) pairs of height adjustment holes:

⊛ HOLE PAIR #	1	2	3	4	5
Back Height (in inches)	16	17	18	19	20

⊛ Holes numbered from bottom to top for reference only. (There are no numbers on the back canes.)

3. Reinstall the two (2) hex bolts that secure the top half of the back cane to the bottom half of the back cane.

WARNING

The top and bottom half of the back canes **MUST** be tightened securely together **BEFORE** using the wheelchair, otherwise injury or damage may occur. Use Loctite 242 on the hex bolts and torque to 75-inch pounds.

4. Use Loctite 242 on the hex bolts and torque into the back canes to 75-inch pounds.
5. While holding the hex bolt, reinstall the locknut and torque to 75-inch pounds.
6. Repeat STEP 5 for the other hex bolt and locknut.
7. Repeat STEPS 1-6 for the opposite back cane.

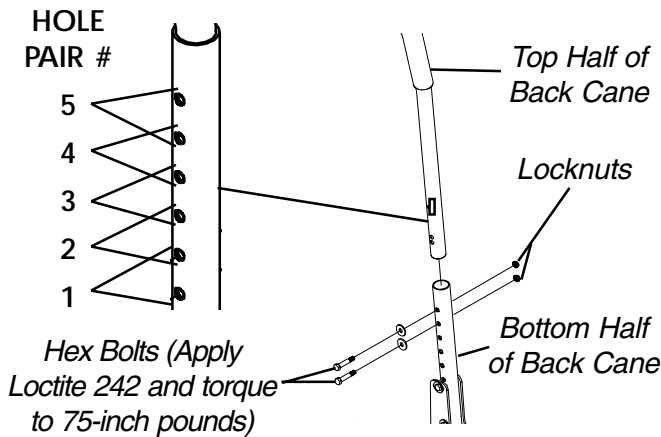

FIGURE 5 - CHANGING BACK HEIGHT - WHEELCHAIRS BUILT AFTER 10/2000

CHANGING BACK ANGLE

Wheelchairs Built After 10/2000 (FIGURE 6)

1. Flip the armrests up and out of the way. Refer to USING/ADJUSTING FLIP BACK ARMRESTS in PROCEDURE 5 of this manual.
2. Remove the TOP hex bolt, two (2) washers and locknut that secure the back cane to the mounting plate on the wheelchair frame.

3. Refer to DETAIL "B" in FIGURE 6 to determine the mounting plate hole for the desired back angle.
4. Reposition the back cane to the position determined in STEP 3.
5. Reinstall TOP hex bolt, two (2) washers and locknut. Refer to FIGURE 6 for correct hardware orientation.

WARNING

The back canes **MUST** be tightened securely to the wheelchair frame **BEFORE** using the wheelchair, otherwise injury or damage may occur. Use Loctite 242 on the hex bolt and torque to 75-inch pounds.

6. Use Loctite 242 on the hex bolt and torque the hex bolt to 75-inch pounds.
7. Repeat STEPS 2-6 for opposite side of wheelchair.

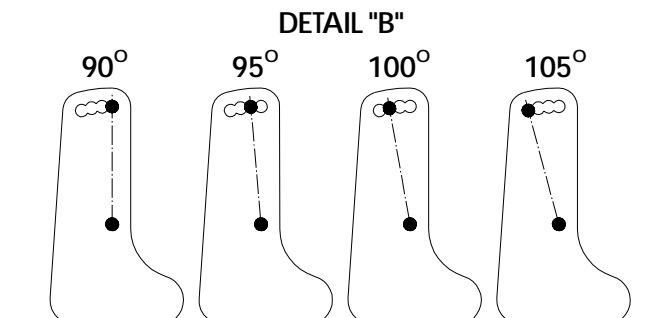
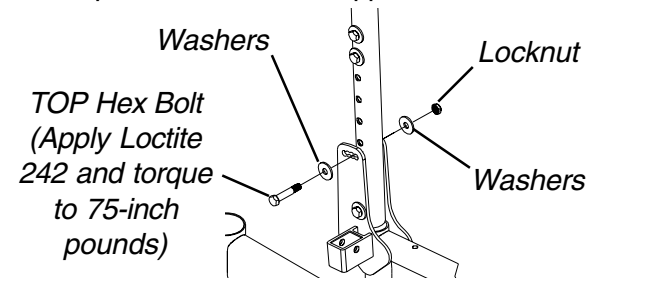

FIGURE 6 - CHANGING BACK ANGLE - WHEELCHAIRS BUILT AFTER 10/2000

Wheelchairs Built Before 10/2000 (FIGURE 7)

1. Remove armrests from the wheelchair.
2. Remove the hex bolt, washer and locknut from the top mounting hole of **mounting plate** and **back cane**.

NOTE: To keep inserts lined up for reinstallation onto wheelchair, install one (1) of the hex bolts through back cane from the inside of the wheelchair to hold the insert in place.

3. Remove hex screw, washer and locknut from bottom mounting hole of **mounting plate** and **back cane**.
4. Reposition back canes into the desired mounting holes of the **mounting plate** to obtain a back angle between 85° and 105° in 5° increments.
5. Use Loctite 242 and torque hex bolts to 75-inch pounds.
6. Reinstall the armrests onto the wheelchair.

FRAME

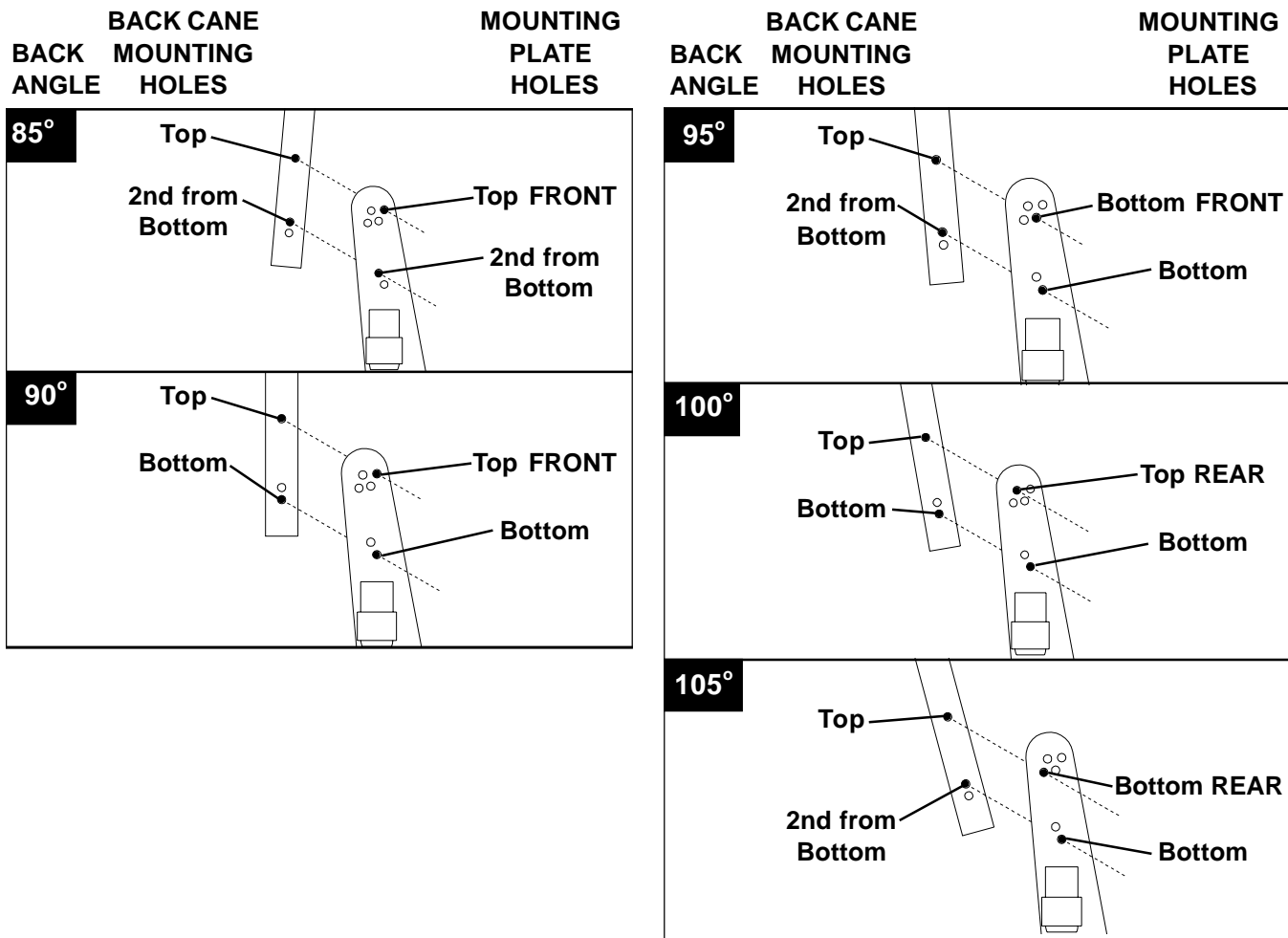

FIGURE 7 - CHANGING BACK ANGLE - WHEELCHAIRS BUILT BEFORE 10/2000

REPLACING BACK CANES - WHEELCHAIRS BUILT AFTER 10/2000 ONLY (FIGURE 8)

Top Half of Back Canes

1. Flip the armrests up and out of the way. Refer to USING/ADJUSTING FLIP BACK ARMRESTS in PROCEDURE 5 of this manual.

NOTE: If the back height of the wheelchair is staying the same, note the position of the existing top half of the back cane(s) before removing from the wheelchair.

2. Remove the phillips screw and washer that secure the back upholstery to the existing top half of the back cane.
3. Slide the back upholstery up to expose the two (2) hex bolts, washers and locknuts.
4. Remove the two (2) hex bolts, washers and locknuts that secure the existing top half of the back cane to the bottom half of the back cane.
5. Remove the existing top half of the back cane from the bottom half of the back cane.

6. Perform one (1) of the following:
 - A. Install the new top half of the back cane through the back upholstery and into the bottom half of the back cane at the existing position noted.
 - B. Install the new top half of the back cane through the back upholstery and into the bottom half of the back cane to one (1) of the following new positions:

⊕ HOLE PAIR #	1	2	3	4	5
Back Height (in inches)	16	17	18	19	20

⊕ Holes numbered from bottom to top for reference only. (There are no numbers on the back canes.)

7. Reinstall the two (2) hex bolts that secure the new top half of the back cane to the bottom half of the back cane.

WARNING

The top and bottom half of the back canes **MUST** be tightened securely together **BEFORE** using the wheelchair, otherwise injury or damage may occur. Use Loctite 242 on the hex bolts and torque to 75-inch pounds.

8. Use Loctite 242 on the hex bolts and torque into the back canes to 75-inch pounds.
9. While holding the hex bolt, reinstall the locknut and torque to 75-inch pounds.
10. Repeat STEP 9 for the other hex bolt and locknut.
11. Securely tighten back upholstery to the new top half of the back cane with the phillips screw and washer.
12. Repeat STEPS 2-11 for the opposite side of the wheelchair, if necessary.

Bottom Half of Back Canes

1. Flip the armrests up and out of the way. Refer to USING/ADJUSTING FLIP BACK ARMRESTS in PROCEDURE 5 of this manual.
2. Remove phillips screw and washer that secure back upholstery to the existing top half of the back cane.
3. Slide the back upholstery up to expose the two (2) hex bolts, washers and locknuts.
4. Remove the two (2) hex bolts, washers and locknuts that secure the top half of the back cane to the existing bottom half of the back cane.
5. Remove the top half of the back cane from the existing bottom half of the back cane.

NOTE: If the back angle of the wheelchair is staying the same, note the position of the existing bottom half of the back cane(s) before removing from the wheelchair.

6. Remove the two (2) hex bolts, four (4) washers and two (2) locknuts that secure the bottom half of the back cane to the wheelchair.
7. Remove the existing bottom half of the back cane from the wheelchair.

NOTE: The existing insert will be reused.

8. Remove the insert from the existing bottom half of the back cane.
9. Install the insert into the new bottom half of the back cane and line up the mounting holes.
10. Install the new bottom half of the back cane onto the wheelchair at the position noted.

NOTE: If the back angle needs to be changed, refer to CHANGING BACK ANGLE in this procedure of the manual.

11. Reinstall the two (2) hex bolts, four (4) washers and two (2) locknuts that secure the new bottom half of the back cane to the wheelchair.

WARNING

The back canes **MUST** be tightened securely to the wheelchair frame **BEFORE** using the wheelchair, otherwise injury or damage may occur. Use Loctite 242 on the hex bolts and torque to 75-inch pounds.

12. Use Loctite 242 on the hex bolts and torque the hex bolts to 75-inch pounds.
13. Securely tighten back upholstery to the top half of the back cane with the phillips screw and washer.
14. Repeat STEPS 2-13 for the opposite side of the wheelchair, if necessary.

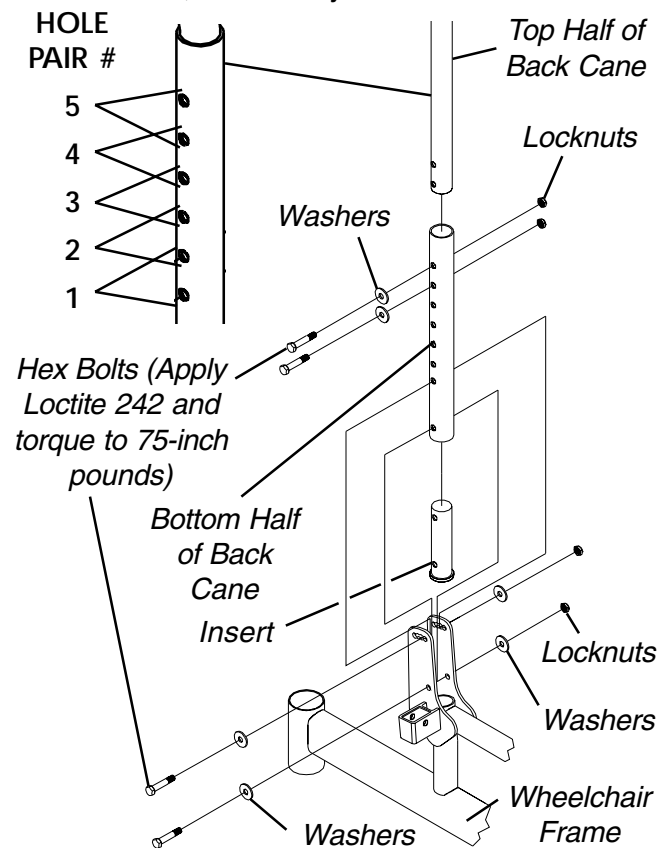

FIGURE 4 - REPLACING BACK CANES - WHEELCHAIRS BUILT AFTER 10/2000 ONLY

- This Procedure includes the following:**
- Installing/Removing Batteries into/From Battery Boxes
 - Connecting Battery Cables
 - When to Charge Batteries
 - Charging Batteries
 - Replacing Batteries
 - Installing/Removing Battery Tray
 - Removing/Installing Battery Boxes

NOTE: When securing battery lifting strap to battery, observe polarity markings located on the ends of the battery lifting strap, (+) side to POSITIVE (+) battery terminal/post and (-) side to NEGATIVE (-) battery terminal/post.

1. If necessary, remove the battery boxes from the wheelchair. Refer to INSTALLING/REMOVING BATTERY BOXES in this procedure of the manual.
2. Secure the battery lifting strap to battery terminal(s)/post(s) (FIGURE 1).

WARNING

After ANY adjustments, repair or service and BEFORE use, make sure all attaching hardware is tightened securely - otherwise injury or damage may result.

CAUTION

Some battery manufacturers mold a carrying strap and/or hold down flanges directly into the battery case. Batteries which interfere with the battery box cannot be used for these applications. Attempting to "wedge" a battery into a battery box may damage the box and/or the battery.

3. Place batteries into battery box bottom.

INSTALLING/REMOVING BATTERIES INTO/FROM BATTERY BOXES (FIGURE 1)

NOTE: To remove the battery(ies) from the battery box(es), reverse the following procedure.

NOTE: Have the following tools available:

TOOL	QTY	COMMENTS
Battery Lifting Strap	1	See Note
1/2-inch (6 pt) Box Wrench	1	Not Supplied
7/16-inch (6pt) Box Wrench	1	Not Supplied
3/8-inch (6pt) Box Wrench	1	Not Supplied
Diagonal Cutters	1	Not Supplied

***NOTE:** The Battery Lifting strap supplied is for Group 22 NF Batteries ONLY. Refer to the battery manufacturer for the proper lifting strap and/or battery tools for U1 battery removal/installation.

WARNING

Always use a battery lifting strap when lifting a battery. It is the most convenient method and assures that the battery acid will not spill. It also helps to prolong the life of the battery.

DO NOT tip the batteries. Keep the batteries in an upright position.

NOTE: If there is battery acid in the bottom or on the sides of the battery box(es) or battery(ies), apply baking soda to these areas to neutralize the battery acid. Before reinstalling the NEW or existing battery(ies), clean the baking soda from the battery box(es) or battery(ies).

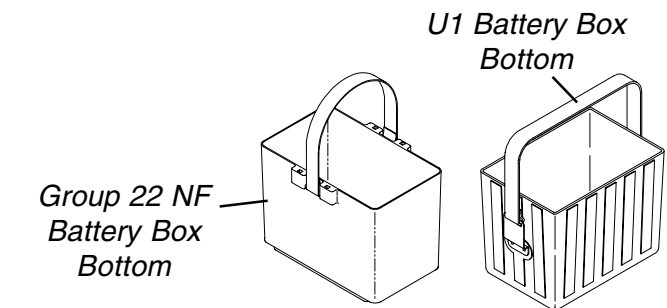
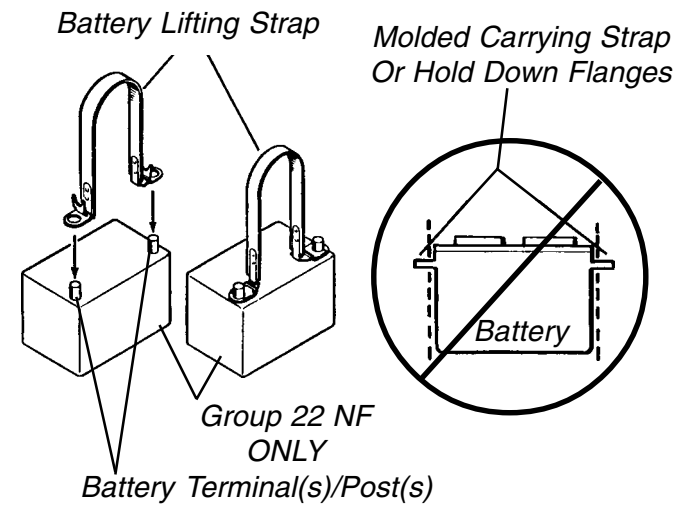

FIGURE 1 - INSTALLING/REMOVING BATTERIES INTO/FROM BATTERY BOXES

CONNECTING BATTERY CABLES

WARNING

NEVER allow any of your tools and/or battery cable(s) to contact BOTH battery terminal(s)/post(s) at the same time. An electrical short may occur and serious personal injury or damage may occur. The use of rubber gloves and safety glasses is recommended when working with batteries.

CAUTION

When connecting the battery cables to the battery(ies), the battery cable(s) MUST be connected to the battery terminal(s)/post(s) as shown in DETAIL "A" or DETAIL "B" of FIGURE 3 (depending on battery type), otherwise damage to the battery cable may result when installing battery terminal caps.

B
A
T
T
E
R
I
E
S

Dual U1 or Dual Group 22 NF Battery Boxes

Perform one (1) of the following methods for connecting the battery cable(s):

- A. **FOR DUAL U1 BATTERIES** - Use direct mount method. Refer to FIGURES 2, 3 AND 4.
- B. **FOR DUAL GROUP 22 NF BATTERIES THAT HAVE MOUNTING HOLES IN THE BATTERY TERMINAL(S)/POST(S)** - Use direct mount method. Refer to FIGURES 2 AND 3.
- C. **FOR DUAL GROUP 22 NF BATTERIES THAT DO NOT HAVE MOUNTING HOLES IN THE BATTERY TERMINAL(S)/POST(S)** - Use battery clamp method. Refer to FIGURES 5, 6 AND 7.

DIRECT MOUNT METHOD (FIGURE 2, 3 AND 4).

- 1. Install battery terminal cap(s) onto battery cable(s) as follows (FIGURE 2):

DUAL U1 BATTERIES:

- A. ORANGE battery terminal cap onto RED battery cable.
- B. GRAY battery terminal cap onto BLACK battery cable.

DUAL GROUP 22 NF BATTERIES:

- A. RED battery terminal cap onto RED battery cable.
- B. BLACK battery terminal cap onto BLACK battery cable.

INSTALLING BATTERY TERMINAL CAPS

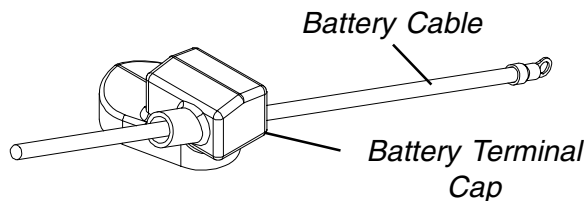

NOTE: Only one (1) battery cable and terminal cap shown for clarity. Both caps install in the same manner.

FIGURE 2 - CONNECTING BATTERY CABLES - DIRECT MOUNT METHOD

- 2. Connect battery cable(s) to battery(ies) terminal(s)/post(s) as follows (DETAIL "A" or DETAIL "B" of FIGURE 3, depending on battery type):
 - A. NEGATIVE (-) BLACK battery cable to NEGATIVE (-) battery terminal/post.
 - B. POSITIVE (+) RED battery cable to POSITIVE (+) battery terminal/post.
- 3. Secure the battery cable(s)/ring terminal(s) to the battery terminal(s)/post(s), BLACK to NEGATIVE (-) and RED to POSITIVE (+), with the provided 1/4-20 x 7/8-inch hex flange screw and hex flange locknut. Securely tighten. (DETAIL "A" or DETAIL "B" of FIGURE 3, depending on battery type).
- 4. Verify all battery cable(s)/ring terminal(s) are correctly installed and securely tightened.
- 5. Slide terminal cap(s) down battery cable(s) and onto battery clamps (FIGURE 3).
- 6. Secure each terminal cap in place with a tie-wrap (Use tie-wraps 11-1/2-inches long) (FIGURE 3).

NOTE: It will be necessary to trim excess tie-wrap in order to install the battery box top(s).

- 7. Install the battery box top(s).
- 8. Install the battery box(es) into the wheelchair. Refer to INSTALLING/REMOVING BATTERY BOX(ES) in this procedure of the manual.

NOTE: New Battery(ies) MUST be fully charged BEFORE using, otherwise the life of the battery(ies) will be reduced.

- 9. If necessary, charge the battery(ies). Refer to CHARGING BATTERIES in this procedure of the manual.

BATTERIES

DETAIL "A"
DUAL U1 BATTERIES

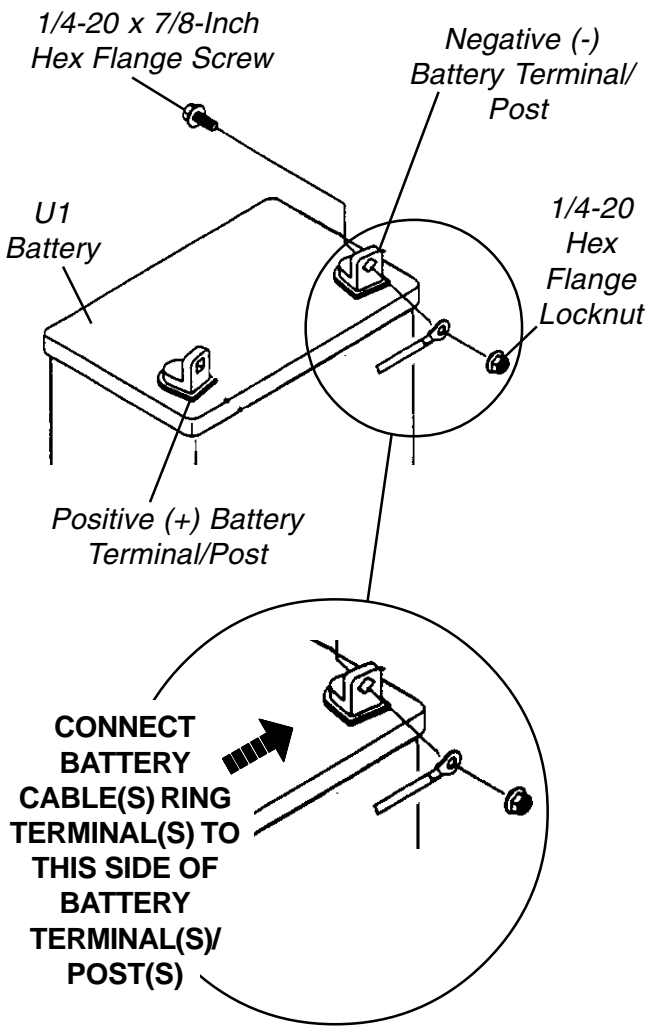

DETAIL "B"
DUAL GROUP 22 NF BATTERIES

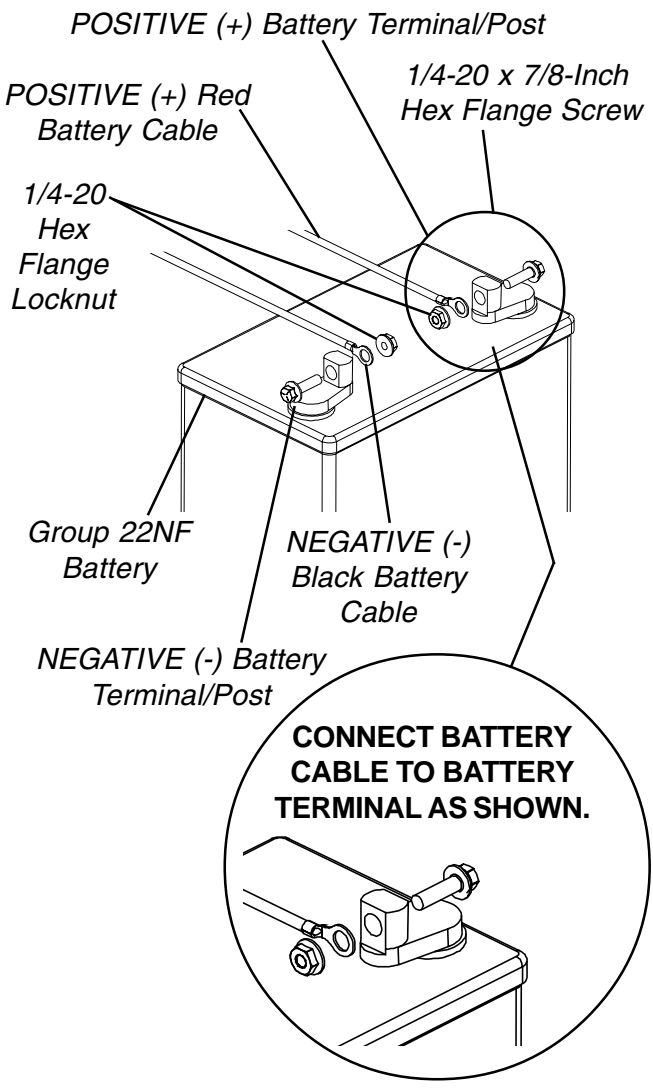

DUAL U1 BATTERIES

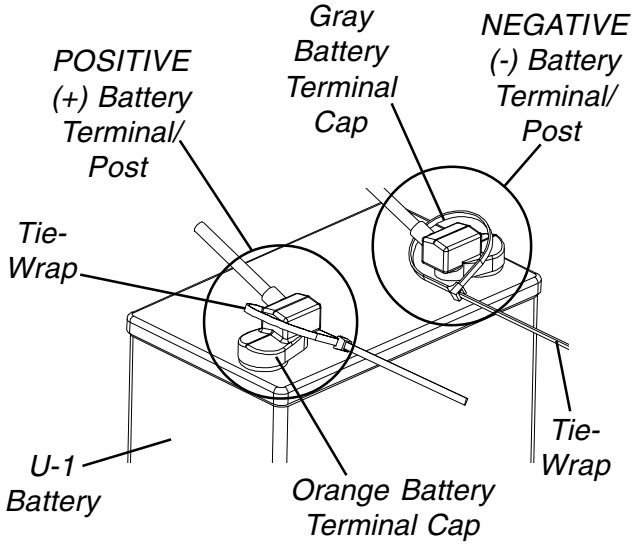

DUAL GROUP 22 NF BATTERIES

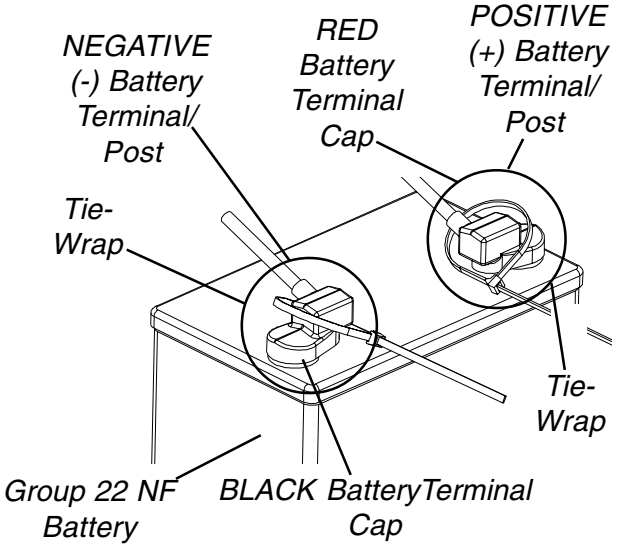

FIGURE 3 - CONNECTING BATTERY CABLES - DIRECT MOUNT METHOD

BATTERY CLAMP METHOD (FIGURES 4, 5 AND 6).

CAUTION

The battery clamp of the POSITIVE (+) battery terminal/post MUST be mounted in the position shown in FIGURE 5, otherwise the battery box top cannot be installed properly.

1. Perform one (1) of the following:
 - A. If the battery clamp of the POSITIVE (+) battery terminal/post is **NOT** mounted in the orientation shown in FIGURE 5, perform the following:
 - Loosen the hex nut that secures the battery clamp to the POSITIVE (+) battery terminal/post.
 - B. If the battery clamp on the POSITIVE (+) battery terminal/post is positioned as shown in FIGURE 4, proceed to STEP 2.

CORRECT ORIENTATION OF THE POSITIVE (+) BATTERY TERMINAL/POST BATTERY CLAMP

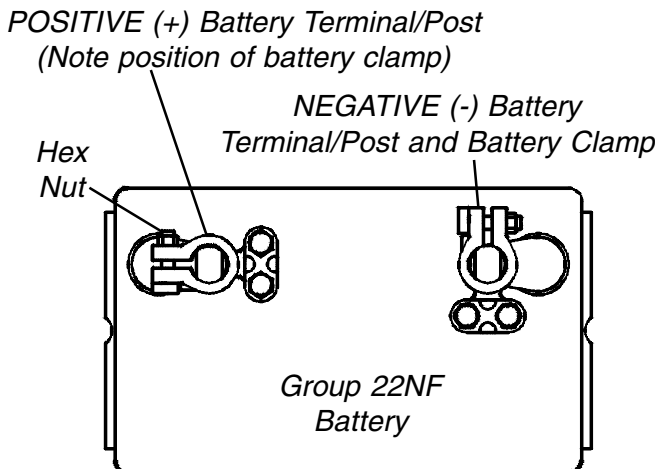

FIGURE 4 - CONNECTING BATTERY CABLES - BATTERY CLAMP METHOD

2. Install battery clamp covers onto battery cables as follows: (FIGURE 5)
 - A. RED battery clamp cover onto RED battery cable.
 - B. BLACK battery clamp cover onto BLACK battery cable.

NOTE: Only one (1) battery cable and battery clamp cover are shown for clarity. Both battery clamp covers install in the same manner.

INSTALLING BATTERY CLAMP COVERS

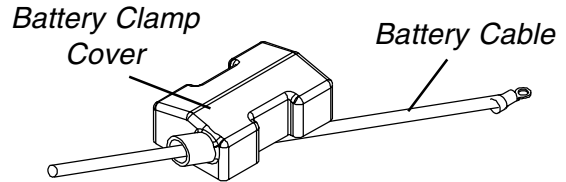

FIGURE 5 - CONNECTING BATTERY CABLES - BATTERY CLAMP METHOD

CAUTION

When connecting the battery cable/ring terminal(s) to the battery(ies) clamp(s), the battery cable(s) MUST be connected in the position shown in DETAIL "A", otherwise damage may occur to the battery cable and/or battery clamp covers.

3. Connect battery cable(s) to battery(ies) terminal(s)/post(s) as follows (DETAIL "A"):
 - A. NEGATIVE (-) BLACK battery cable/ring terminal between the mounting plate and battery clamp of NEGATIVE (-) battery terminal/post.
 - B. POSITIVE (+) RED battery cable/ring terminal between the mounting plate and battery clamp of POSITIVE (+) battery terminal/post.
 4. Secure the battery cable(s)/ring terminal(s) to the battery clamp(s), BLACK to NEGATIVE (-) and RED to POSITIVE (+), with existing hex screws. Securely Tighten. (DETAIL "A")
 5. Verify battery cable ring terminal(s) are correctly installed and securely tightened.
 6. Slide battery clamp covers down battery cables and onto battery terminals. (DETAIL "B")
 7. Secure each terminal cap in place with a tie-wrap (Use tie-wraps 11-1/2-inches long). (DETAIL "B")
- NOTE: It will be necessary to trim excess tie-wrap in order to install the battery box top(s).*
8. Install the battery box top(s).

9. Install the battery box(es) into the wheelchair. Refer to INSTALLING/REMOVING BATTERY BOX(ES) in this procedure of the manual.

10. If necessary, charge the battery(ies). Refer to CHARGING BATTERIES in this procedure of the manual.

NOTE: New Battery(ies) **MUST** be fully charged **BEFORE** using, otherwise the life of the battery(ies) will be reduced.

CONNECTING BATTERY CABLE(S) TO BATTERY(IES) TERMINAL(S)/POST(S)

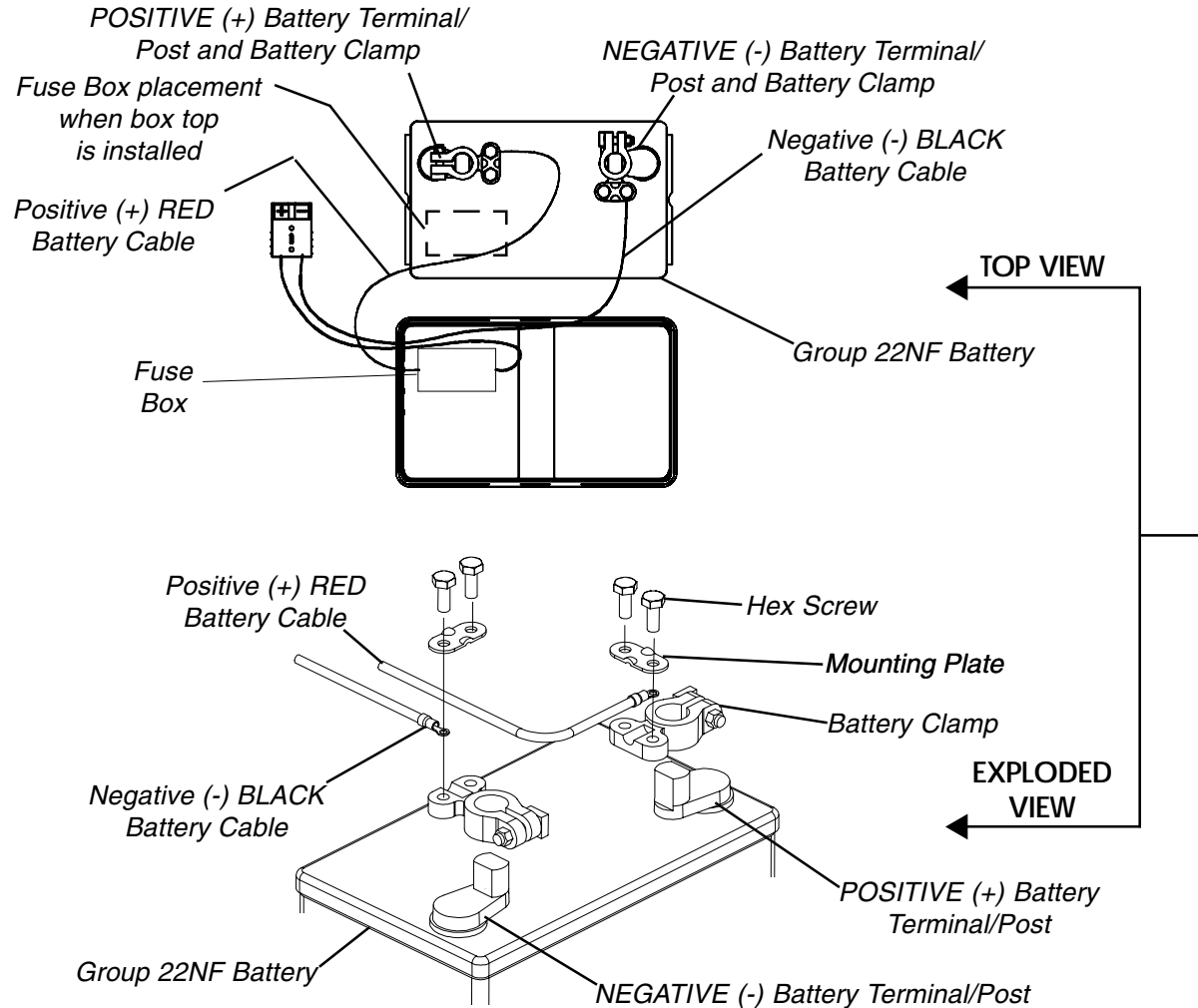

NOTE: Battery clamps exploded away for clarification purposes only.

DETAIL "B"

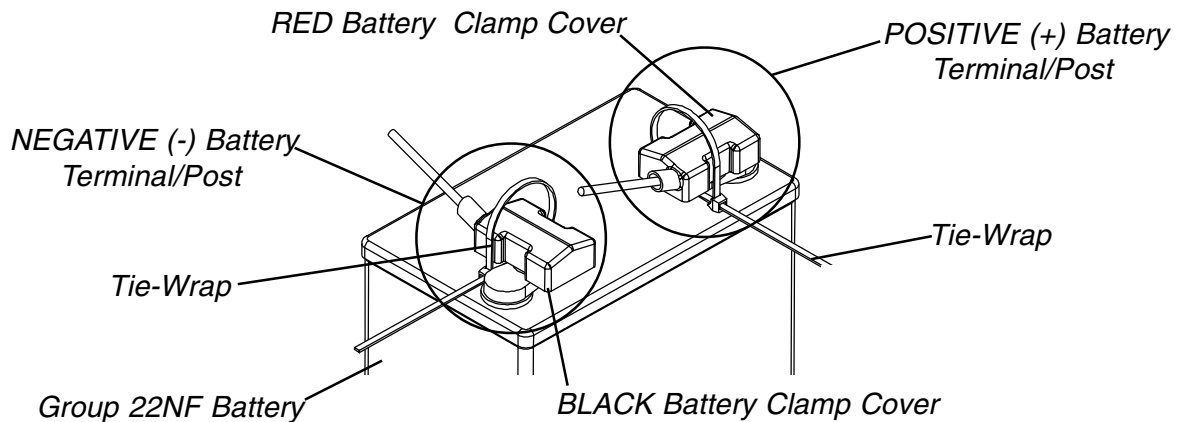

FIGURE 6 - CONNECTING BATTERY CABLES - BATTERY CLAMP METHOD

WHEN TO CHARGE BATTERIES (FIGURE 5)

It is advantageous to recharge frequently rather than only when necessary. In fact, a battery's life is extended if the charge level is maintained well above a low condition.

MKIV RII Joystick

BATTERY DISCHARGE INDICATOR (BDI) is located at the front of the joystick housing and provides information on the remaining charge in the batteries. At FULL charge the BDI will be GREEN. As batteries becomes discharged, the BDI indicator will turn AMBER (YELLOW), then RED and finally FLASHING RED. If BDI is FLASHING RED, the user should charge batteries as soon as possible.

NOTE: Accurate readings are displayed when in neutral.

MCC-MKIV X, A or A+ Joystick

BATTERY GAUGE DISPLAY (BGD) is the bar graph display located on the joysticks. It will keep you informed as to power availability. A visual warning is given before power becomes too low to operate the wheelchair. At full charge the two (2) LEFT segments and the farthest RIGHT segment of the bar graph will be illuminated. As the battery becomes discharged, the farthest RIGHT segment will progressively move to the LEFT until only the last two (2) bars (LEFT) are illuminated. At this level the last two (2) bars (LEFT) will start to Flash ON and OFF to indicate that the user should charge the batteries as soon as possible.

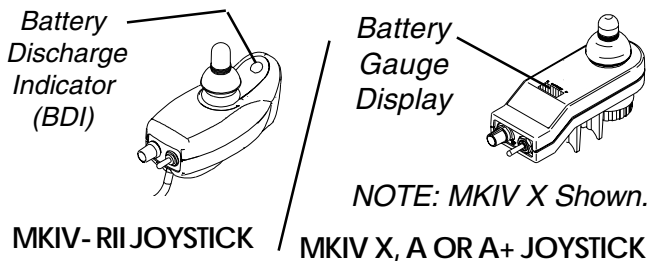

FIGURE 5 - WHEN TO CHARGE BATTERIES

CHARGING BATTERIES (FIGURE 6)

WARNING

Never attempt to recharge the batteries by attaching cables directly to the battery terminals or clamps. Use the recharging plug located on either the side of the wheelchair frame or on the front of the joystick.

DO NOT attempt to recharge the batteries and operate the power wheelchair at the same time.

During use and charging, unsealed batteries will vent hydrogen gas which is explosive in the right concentration with air.

CAUTION

Always charge new batteries fully BEFORE initial use or battery life will be reduced.

NOTE: As a general rule, batteries should be recharged daily to assure the longest possible life and minimize the required charging time. Plan to recharge the batteries when it is anticipated the wheelchair will not be used for a long period of time.

The range per battery charge using recommended batteries should be approximately 5 to 9 hours of typical operation. Extensive use on inclines may substantially reduce per charge mileage.

Description and Use of Battery Chargers

A charger automatically reduces the charge from an initially high rate to a zero reading at a fully charged condition.

SHUTOFF PROCEDURE.

R2_{BASIC/STANDARD} The charger should automatically shut-off when full charge is obtained.

R2_{250 SERIES} The charger output and green light will stay ON until the power switch on the battery charger is moved to the OFF position.

There are some basic concepts which will help you understand this automatic process:

The amount of electrical current drawn within a given time to charge a battery is called "charge rate". If, due to usage, the charge stored in the battery is low, the charge rate is high. (**R2_{BASIC/STANDARD} only** - this is indicated by the green light on the charger. Initially, the green light will stay illuminated for a short period of time followed by a longer period of off time.)

As a charge builds up, the charge rate is reduced, and the following will occur:

R2_{BASIC/STANDARD} The green light will stay illuminated for a longer period of time followed by a shorter off time.

R2_{250 SERIES} Battery charger rate decreases to a "trickle charge".

NOTE: If performing the charging procedures independently, READ and CAREFULLY follow the individual instructions for each charger (supplied or purchased).

NOTE: If charging instructions are not supplied, consult a qualified service technician for proper procedures.

Required Items:

TOOL	QUANTITY	COMMENTS
Battery Charger	1	Supplied
⊕ Extension Cord	1	Not Supplied

⊕ 3-prong plug, 15 ampere current rating; industrial type

Wheelchairs Equipped With MCC-Mark IV Joystick (Detail "A" of FIGURE 6)

1. Attach the battery charger connector to the charger cable/battery harness.

2. Plug the charger's AC power cord, or extension, into the grounded 120 VAC wall outlet.
3. Wait until charging is complete.

NOTE: Allow eight (8) hours for normal charging. Larger batteries (greater than 55 ampere-hours) or severely discharged batteries may require up to sixteen (16) hours to be properly charged and equalized.

NOTE: R2_{BASIC/STANDARD} Only - If charger operates for sixteen (16) hours and is unable to fully charge batteries, an internal timer turns charger off and begins to fast blink green light.

NOTE: If the batteries need to be charged more often or take longer to charge than normal, they may need to be replaced. Contact an Invacare dealer for service.

Wheelchairs Equipped With Mark IV RII Joystick (Detail "B" of FIGURE 6)

1. Attach the battery charger connector to the charger port on the FRONT of the joystick.
2. Plug the charger's AC power cord, or extension, into the grounded 120 VAC wall outlet.
3. Wait until charging is complete.

NOTE: Allow eight (8) hours for normal charging. Larger batteries (greater than 55 ampere-hours) or severely discharged batteries may require up to sixteen (16) hours to be properly charged and equalized.

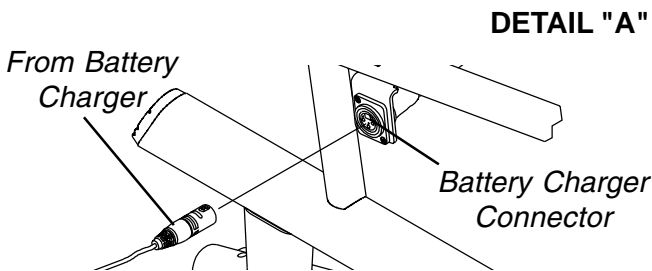

DETAIL "B"

Front View of Joystick

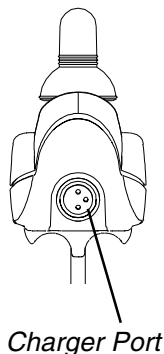

Top View of Wheelchair

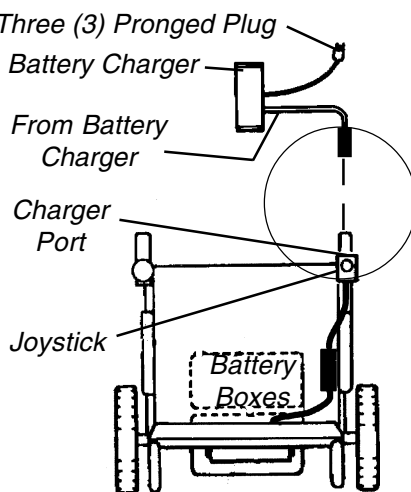

FIGURE 6 - CHARGING BATTERIES

REPLACING BATTERIES

WARNING

Most batteries are not sold with instructions. However, warnings are frequently noted on the cell caps. Read them carefully, otherwise injury or damage can occur.

NOTE: Invacare recommends that both batteries be replaced if one (1) battery is defective.

Recommended Battery Types

WARNING

The warranty and performance specifications contained in this manual are based on the use of deep cycle gel cell or sealed lead acid batteries. Invacare strongly recommends their use as the power source for this unit.

CAUTION

Failure to use the correct battery size and/or voltage may cause damage to your wheelchair and give you unsatisfactory performance.

NOTE: All R2_{250-S} wheelchairs use U1 batteries. Refer to the chart below for R2_{BASIC} and R2_{STANDARD} wheelchairs.

SEAT WIDTH OF CHAIR	QTY	VOLTS	BCI STOCK NO.	REMARKS
14-inches	2	12	U1	Deep Cycle
16,18, 20-inches	2	12	22NF	Deep Cycle

1. Remove the battery boxes from the wheelchair. Refer to REMOVING/INSTALLING BATTERY BOXES in this procedure of the manual.
2. Remove existing batteries from battery boxes. Refer to INSTALLING/REMOVING BATTERIES INTO/FROM BATTERY BOXES in this procedure of the manual.
3. Clean the new battery terminals.
4. Install new batteries into battery boxes. Refer to INSTALLING/REMOVING BATTERIES INTO/FROM BATTERY BOXES in this procedure of the manual.

Cleaning Battery Terminals

WARNING

DO NOT allow the liquid in the battery to come in contact with skin, clothes or other possessions. It is a form of acid and harmful or damaging burns may result. Should the liquid touch your skin, wash the area immediately and thoroughly with cool water. In serious cases or if eye contact is made, seek medical attention IMMEDIATELY.

NEVER smoke or strike a match near batteries. If the caps of the battery cells are removed, NEVER look directly into them while charging batteries.

1. Examine battery clamps and terminals for corrosion.
2. Verify plastic caps are in place over battery cell holes.
3. Clean the terminals and inside the battery clamps by using a battery cleaning tool, wire brush, or medium grade sand paper.

NOTE: When done, areas should be shiny, not dull.

4. Carefully dust off all metal particles.

INSTALLING/REMOVING BATTERY TRAY (FIGURE 7)

NOTE: To remove the battery tray from the wheelchair, reverse the following procedure.

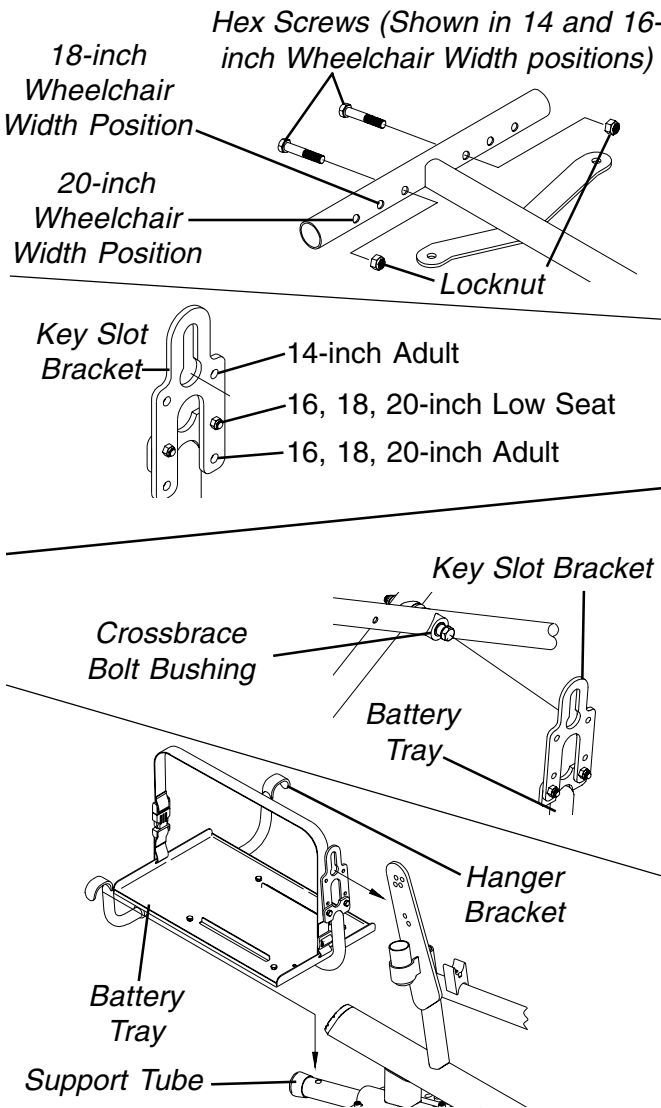

FIGURE 7 - INSTALLING/REMOVING BATTERY TRAY

1. Remove hex screws and locknuts from battery tray.
- NOTE: The hex screws will be positioned in correct mounting holes for the corresponding width of the wheelchair.*

2. Secure the hanger brackets to the battery tray in the mounting holes where the hex screws were mounted.
3. Attach the key slot bracket located at the front of the battery tray over the crossbrace bolt bushing under the seat upholstery of the wheelchair.

NOTE: If wheelchair is 14-inch wide and equipped with MKIV RII electronics, it may be necessary to turn battery tray slightly away from controller to install the battery tray.

4. Attach the hanger brackets to the support tubes on the wheelchair frame.

INSTALLING/REMOVING BATTERY BOXES (FIGURE 8)

WARNING

NEVER unplug the battery cables by pulling on the wires. Unplug the battery cables by pulling on the connector ONLY. Otherwise injury or damage may result.

NOTE: To remove the battery boxes from the wheelchair, reverse the following procedure.

1. Verify joystick ON/OFF switch is in the OFF position.
2. Position battery boxes onto battery tray. Make sure battery cables on battery boxes are on same side as the battery connectors on the wheelchair frame.
3. Connect the battery cables from the battery boxes to the battery connectors on the wheelchair frame.
4. Connect the battery box retaining strap clip together.

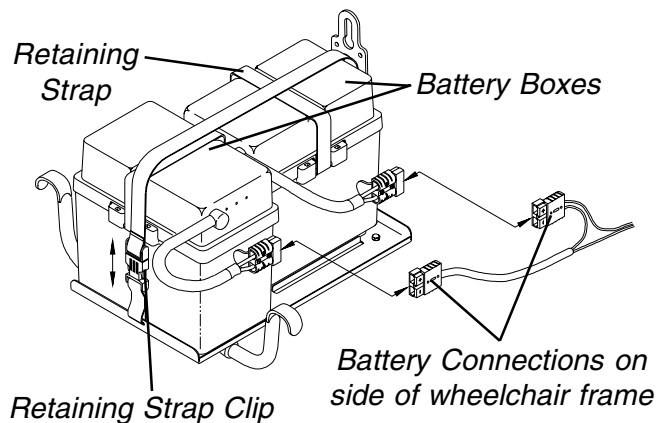

NOTE: Wheelchair Frame not shown for clarity.

FIGURE 8 - INSTALLING/REMOVING BATTERY BOXES

This Procedure includes the following:

- Preparing MKIV Joystick for Use*
- Disconnecting/Connecting MKIV Controller Motor and Battery Leads*
- Repositioning MKIV Joystick*
- Removing/Installing MKIV Controller*

WARNING

After ANY adjustments, repair or service and BEFORE use, make sure all attaching hardware is tightened securely - otherwise injury or damage may result.

PREPARING MKIV JOYSTICK FOR USE (FIGURE 1)

NOTE: The MKIV joystick is factory installed on the right side of the wheelchair. To reposition the MKIV joystick onto the left side of the wheelchair, refer to REPOSITIONING MKIV JOYSTICK in this procedure of the manual.

1. Turn the lever on the adjustment lock to release the adjustment lock from joystick mounting tube.
2. Remove the joystick mounting tube from the adjustment lock.
3. Reposition the joystick mounting tube so that the joystick is facing towards the front of the wheelchair.
4. Slide joystick mounting tube to the desired position.
5. Turn the lever on the adjustment lock to secure the adjustment lock to the joystick mounting tube.

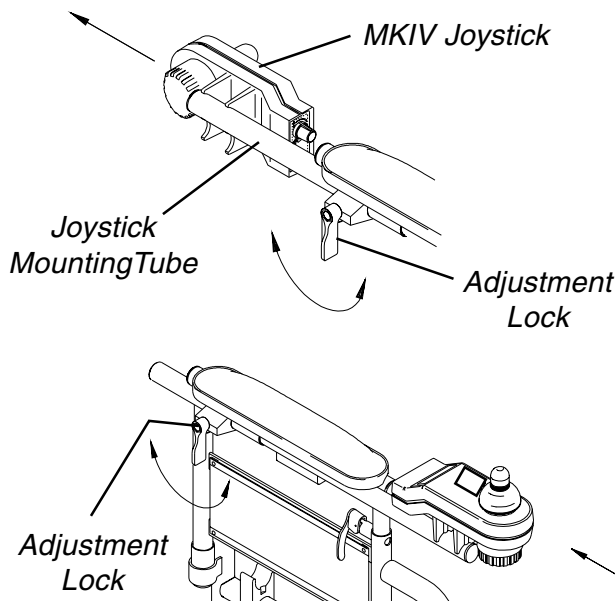

FIGURE 1 - PREPARING MKIV JOYSTICK FOR USE

DISCONNECTING/CONNECTING MKIV CONTROLLER MOTOR AND BATTERY LEADS (FIGURE 2)

NOTE: To connect MKIV controller motor and battery leads, reverse the following procedure.

1. Disconnect the fastening straps that secure the nylon boot around the connected motor and battery leads.
2. Disconnect the controller left/right motor and battery leads from leads secured to wheelchair with tie wraps.

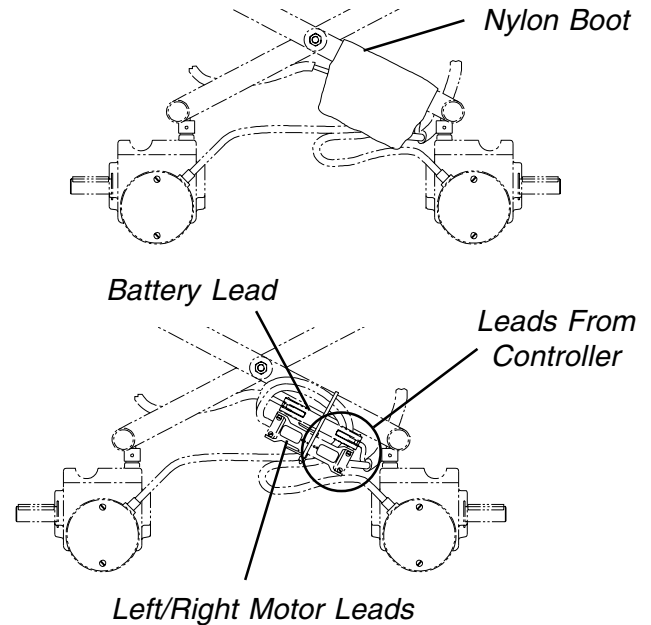

FIGURE 2 - DISCONNECTING/CONNECTING MKIV CONTROLLER MOTOR AND BATTERY LEADS

REPOSITIONING MKIV JOYSTICK (FIGURE 3)

1. Turn the lever on the adjustment lock to release the adjustment lock from joystick mounting tube (**tube**).
2. Remove the joystick from the wheelchair.
3. Remove the three (3) hex screws that secure the joystick mounting bracket (**bracket**), threaded hole half clamp and opened hole half clamp to the arm tube.
4. Reposition threaded hole half clamp and opened hole half clamp on opposite arm tube. Make sure threaded hole half clamp is on the inside of the arm tube.
5. While holding the two (2) half clamps, install front hex screw into the two (2) half clamps and securely tighten.
6. Line up the mounting holes of joystick mounting bracket with the mounting holes in the two (2) half clamps.

7. Secure the joystick mounting bracket to the two (2) half clamps with the remaining two (2) hex screws.
8. Slide tube through bracket to the desired position.
9. Slide the adjustment lock over the end of the tube and secure the adjustment lock to the tube by turning the lever on the adjustment lock.

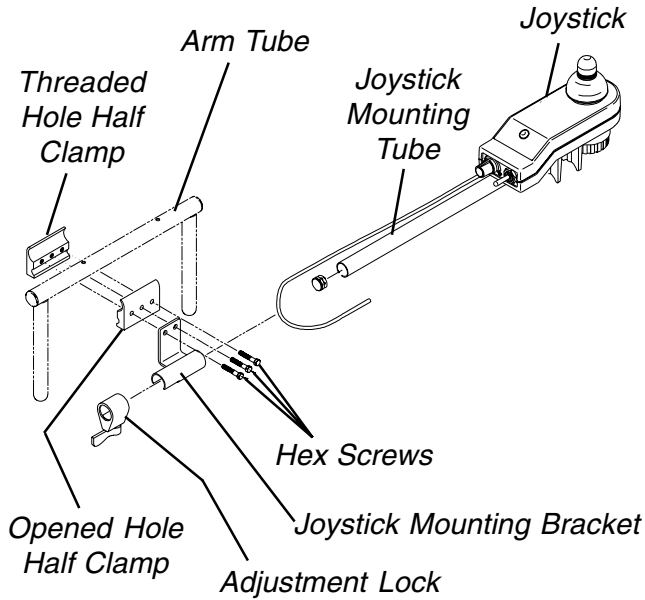

FIGURE 3 - INSTALLING MKIV JOYSTICK

REMOVING/INSTALLING MKIV CONTROLLER (FIGURE 4)

1. Disconnect the left/right motor leads and battery leads.
2. Remove the two (2) hex screws that secure the MKIV controller onto the wheelchair.

NOTE: When installing the MKIV controller onto the wheelchair, use Loctite 242 on hex screws.

3. Install the MKIV controller onto the wheelchair by reversing STEPS 1 and 2.

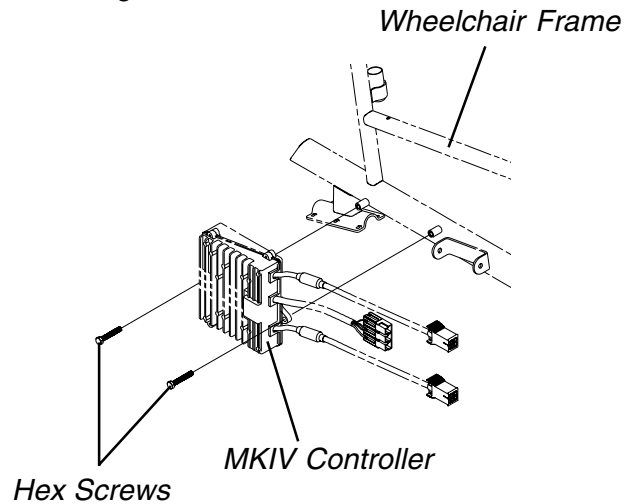

FIGURE 4 - REMOVING/INSTALLING MKIV CONTROLLER

ELECTRONICS

RETAINING STRAP

This Procedure includes the following:
Replacing Battery Box Retaining Strap

WARNING
After ANY adjustments, repair or service and BEFORE use, make sure all attaching hardware is tightened securely - otherwise injury or damage may result.

REPLACING BATTERY BOX RETAINING STRAP (FIGURE 1)

1. Remove the battery boxes. Refer to INSTALLING/REMOVING BATTERY BOXES in PROCEDURE 8 of this manual.

WARNING
The retaining strap MUST be fed through the adjustable end of the battery box retaining strap clip as shown in FIGURE 1.

2. Feed the existing battery box retaining strap through the adjustable end of the battery box retaining strap buckle.

3. Feed the existing battery box retaining strap through the slot in the battery box tray.
4. Feed the new battery box retaining strap through the inside of the slot in the battery box tray.
5. Feed the new battery box retaining strap through the adjustable end of the battery box retaining strap buckle.
6. Reinstall the battery box. Refer to INSTALLING/REMOVING BATTERY BOXES in PROCEDURE 8 of this manual.

WARNING
The Battery Box Retaining Strap MUST be fastened securely in place before using the wheelchair.

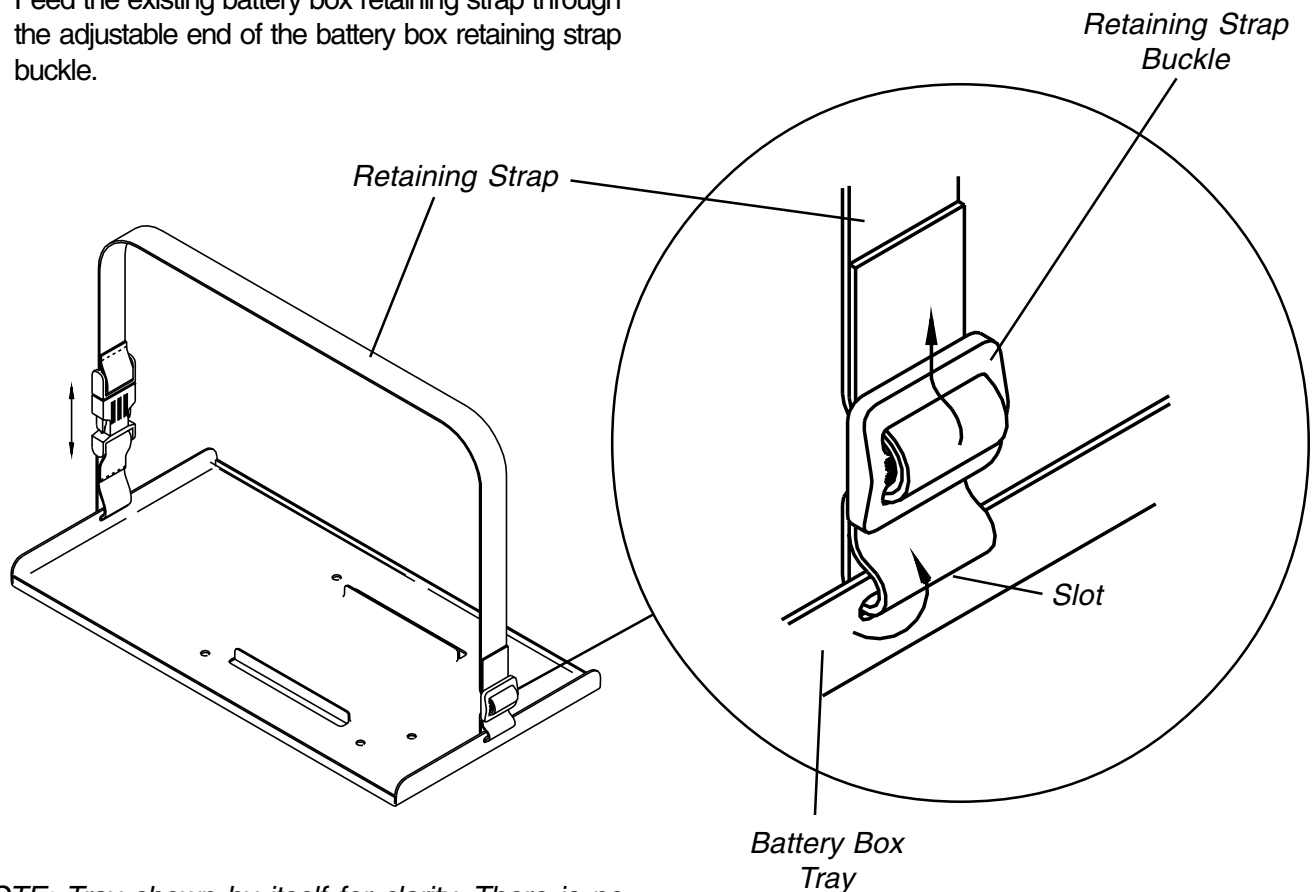

NOTE: Tray shown by itself for clarity. There is no need to remove the tray from the wheelchair if the retaining strap is being replaced.

FIGURE 1 - REPLACING BATTERY BOX RETAINING STRAP

This Procedure includes the following:
Replacing Wiring Harness

WARNING
 After ANY adjustments, repair or service and BEFORE use, make sure all attaching hardware is tightened securely - otherwise injury or damage may result.

REPLACING WIRING HARNESS (FIGURE 1)

WARNING
 The following procedure should be performed only by an authorized Invacare dealer or qualified technician.

Disassembly

1. Remove the battery boxes. Refer to INSTALLING/REMOVING BATTERY BOXES in PROCEDURE 8 of this manual.
2. **Disconnect the following cables:**
 - a. The right and left motor connectors from the controller connectors.
 - b. The wiring harness (BLUE) from the controller connector (BLUE).

3. Remove the four (4) phillips screws that secure the battery connectors and battery connector spacers to the wheelchair frame.
4. Remove the two (2) phillips screws, washers and locknuts that secure the charger cable to the charger cable mounting bracket.
5. Cut the tie wrap that secures the wiring harness and motor cables to the crossbraces.
6. Remove the wiring harness from the wheelchair.

Reassembly

1. Secure the two (2) battery connectors of the new battery harness and the battery connector spacers to the wheelchair frame with the four (4) phillips screws.
2. Secure the charger cable to existing mounting bracket on the seat frame with the two (2) phillips screws, washers and locknuts.
3. **Connect the following cables:**
 - a. The right and left motor connectors to the controller connectors.
 - b. The wiring harness (BLUE) to the controller connector (BLUE).
4. Re-secure the wiring harness and motor cables to the crossbraces with new tie wrap.
5. Reinstall the battery boxes. Refer to INSTALLING/REMOVING BATTERY BOXES in PROCEDURE 8 of this manual.

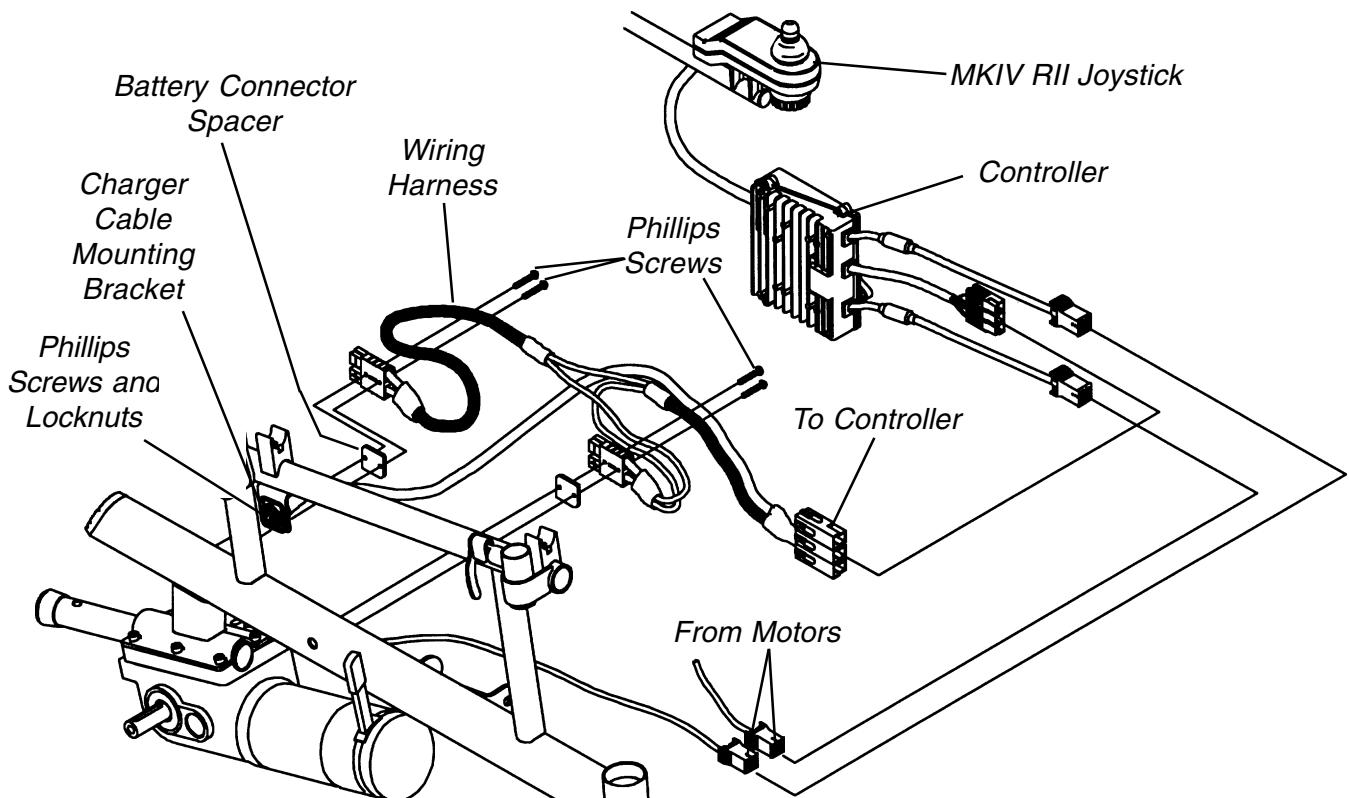

FIGURE 1 - REPLACING WIRING HARNESS

- This Procedure includes the following:*
- Disengaging/Engaging Motors With Motor Locks*
 - Disengaging/Engaging Motors With Clutches*
 - Using/Installing/Adjusting Wheel Locks*
 - Replacing Pneumatic Tires and Tubes - Front Casters and Rear Wheels*
 - Installing/Replacing Rear Wheels*
 - Installing/Replacing Front Casters*
 - Replacing Front Fork*
 - Installing/Removing Anti-Tippers*
 - Installing Optional Clutch Extension Handles - Motors With Clutches Only*

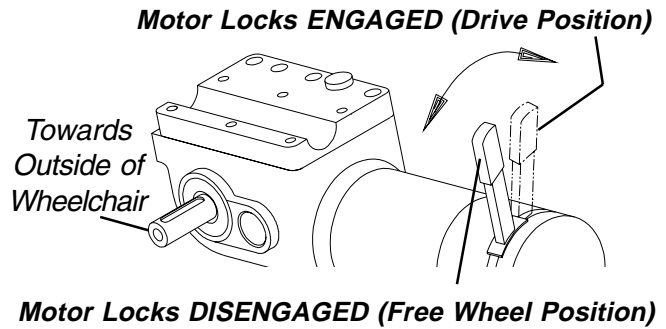

FIGURE 1 - DISENGAGING/ENGAGING MOTORS WITH MOTOR LOCKS

DISENGAGING/ENGAGING MOTORS WITH CLUTCHES (FIGURES 2 AND 3)

WARNING
DO NOT engage or disengage the clutches until the power is in the OFF position.

The clutch engagement/disengagement allows freewheeling or joystick controlled operation. Freewheeling allows an attendant to maneuver the wheelchair without power. To engage/disengage the clutches:

NOTE: If the wheelchair is equipped with clutch extension handles, refer to STEP 1 below. If wheelchair is not equipped with clutch extension handles, proceed to STEP 2.

WARNING
The tabs on the battery box connectors MUST be assembled as shown in FIGURE 2. Otherwise the connectors will not engage completely and clutch handles could disengage connectors.

DISENGAGING/ENGAGING MOTORS WITH MOTOR LOCKS (FIGURE 1)

WARNING
DO NOT engage or disengage the motor locks until the power is in the OFF position.

The motor lock disengagement/engagement allows freewheeling or joystick controlled operation. Freewheeling allows an attendant to maneuver the wheelchair without power. To disengage/engage the motor locks:

1. Locate the motor lock levers on the motors.
2. Perform one (1) of the following:
DISENGAGE - push motor lock levers until they are pointing towards outside of wheelchair (free wheeling position).
ENGAGE - pull motor lock handles until they are pointing straight up (drive position).

14-INCH WIDE WHEELCHAIRS 16-20-INCH WIDE WHEELCHAIRS

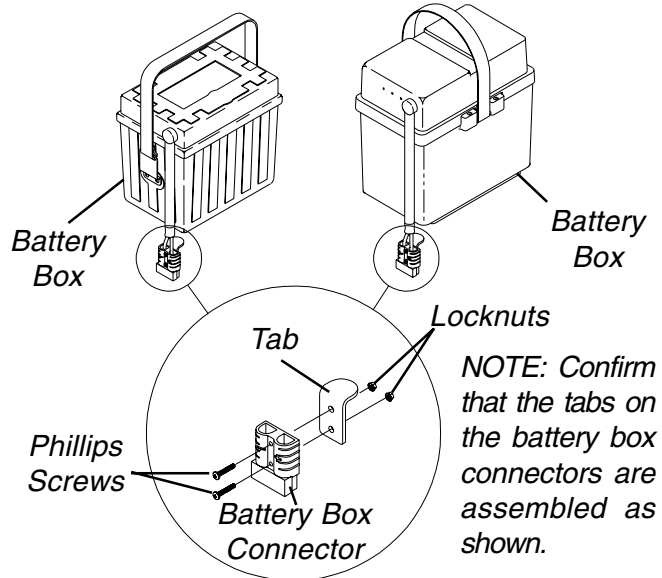

FIGURE 2 - BATTERY BOX CONNECTOR TABS

1. Confirm that the tabs on the battery box connectors are assembled as shown in FIGURE 2.

NOTE: If tab on the battery box connectors is not assembled as shown in FIGURE 2, remove the phillips screws and locknuts to assemble the tab onto the connector correctly.

2. Locate the clutch handles on motors (FIGURE 3).

CAUTION

If clutch handles are forced to engage in the wrong direction (FIGURE 3), the motors will be damaged and will need to be replaced.

3. Perform one (1) of the following (FIGURE 3):

ENGAGE - Turn clutch handles until they are pointing towards rear of wheelchair. **NEVER** try to turn the clutch handles towards the **FRONT** of the wheelchair.

DISENGAGE - Turn clutch handles until they are pointing towards rear wheels. **NEVER** try to turn the clutch handles towards the **INSIDE** of the wheelchair.

TOP VIEW OF WHEELCHAIR

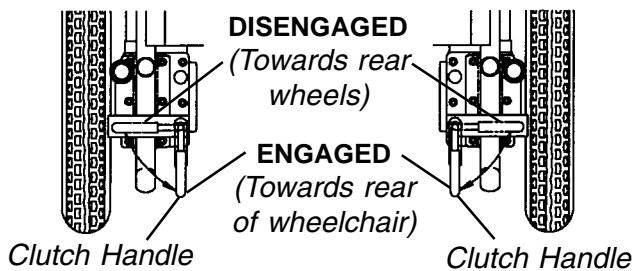

NEVER Force clutch handles in these directions

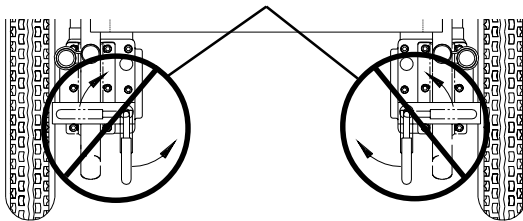

FIGURE 3 - DISENGAGING/ENGAGING MOTORS WITH CLUTCHES

USING/INSTALLING/ADJUSTING WHEEL LOCKS* (FIGURES 4 AND 5)

WARNING

*Wheel locks are an **OPTION** on this wheelchair, (you may order with or without wheel locks). Transfer to and from the wheelchair in the presence of a qualified healthcare professional to determine individual safety limits. Invacare strongly recommends ordering the wheel locks as an additional safeguard for the wheelchair user.

Using Wheel Locks

The wheelchair is optionally equipped with a pair of independently operated wheel locks located just in front of the rear wheels.

1. To engage the wheel locks, grip the handle and push forward to the lock position.
2. To release, reverse STEP 1.

IMPORTANT NOTE: *DO NOT attempt to drive the wheelchair when the wheel locks are engaged.*

NOTE: Use the wheel locks to hold the wheelchair whenever the motor locks are disengaged.

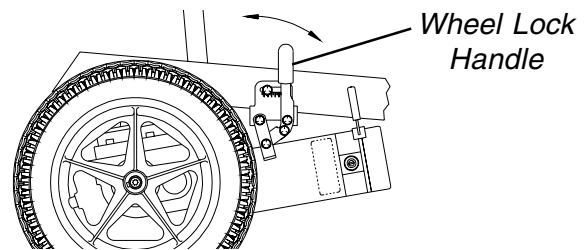

FIGURE 4 - USING WHEEL LOCKS

Installing/Adjusting Wheel Locks

NOTE: Before adjusting or replacing the wheel lock assemblies, ensure that the tires are inflated to the recommended psi on the side wall of tire.

1. Position the wheel lock on the wheelchair frame.
2. Loosely install the hex screw that secures the wheel lock to the wheelchair frame.
3. Make sure wheel lock is disengaged from rear wheel.
4. Measure the distance between the **WHEEL LOCK SHOE** and the **REAR WHEEL**.
5. Slide the wheel lock along the wheelchair until the measurement is between 5/32 and 5/16-inches.
6. Tighten the wheel lock to the wheelchair frame.
7. Repeat this procedure for the opposite wheel lock.

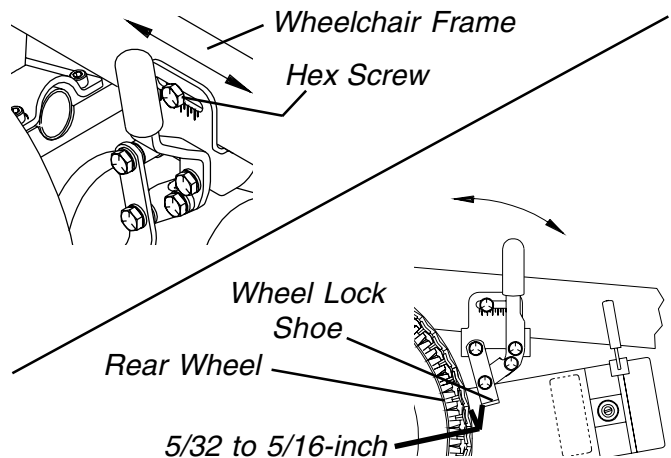

FIGURE 5 - INSTALLING/ADJUSTING WHEEL LOCKS

8. Disengage the following:

MOTORS w/MOTOR LOCKS - Motor locks. Refer to DISENGAGING/ENGAGING MOTORS WITH MOTOR LOCKS in this procedure of the manual.

MOTORS w/CLUTCHES - Clutches. Refer to DISENGAGING/ENGAGING MOTORS WITH CLUTCHES in this procedure of the manual.

9. Engage the wheel locks and push against the wheelchair to determine if the wheel locks engage the rear wheels enough to hold the wheelchair.

10. Repeat STEPS 3-8 until the wheel locks engage the rear wheels enough to hold the wheelchair.

11. Engage the following:

MOTORS w/MOTOR LOCKS - Motor locks. Refer to DISENGAGING/ENGAGING MOTORS WITH MOTOR LOCKS in this procedure of the manual.

MOTORS w/CLUTCHES - Clutches. Refer to DISENGAGING/ENGAGING MOTORS WITH CLUTCHES in this procedure of the manual.

3. Install the new/existing rear wheel onto the motor drive shaft. Make sure the chamfered side of the wheel hub is pointing away from the wheelchair.
4. Install washer onto motor drive shaft.
5. Install the **NEW** locking tab washer onto the motor drive shaft. Make sure the locking tab is in line with the keyway of the rear wheel.
6. Apply Loctite 242 to the hex screw.
7. Install the hex screw. Use a torque wrench only and torque to 90-inch pounds.
8. Examine head of hex screw and locking tab washer. Make sure one (1) of the tabs on locking tab washer is parallel with one (1) of the flats on head of hex screw.
9. If one (1) of the tabs on the locking tab washer is NOT parallel with one (1) of the flats on the head of the hex screw (FIGURE 6), **TIGHTEN** the hex screw until the closest flat and locking tab are parallel.

REPLACING PNEUMATIC TIRES AND TUBES - FRONT CASTERS AND REAR WHEELS

WARNING

DO NOT use your power wheelchair unless it has the proper tire pressure (p.s.i.). DO NOT overinflate the tires. Failure to follow these suggestions may cause the tire to explode and cause bodily harm.

If tires are pneumatic, replacement of tire or tube MUST be performed by a qualified technician.

NOTE: If front casters or rear wheels are pneumatic, under-inflation causes excessive wear which results in poor performance of the tires.

INSTALLING/REPLACING REAR WHEELS (FIGURE 6)

WARNING

NEVER use a locking tab washer more than once. ALWAYS use a NEW locking tab washer when installing the rear wheels.

1. Remove the hex screw, lockwasher and washer that secure the existing rear wheel assembly to the wheel hub assembly.
2. Use a wheel puller to remove the existing rear wheel assembly from the motor drive shaft.

NOTE: The keystone in the wheel hub MUST lineup with the cutout in the gearbox drive shaft.

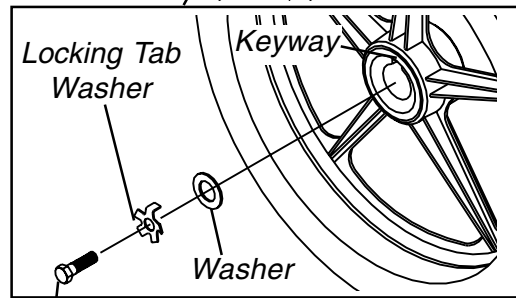
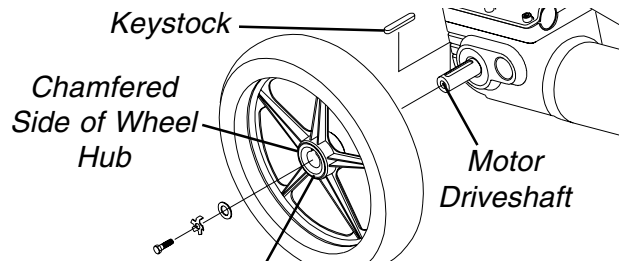

Hex Screw (Apply Loctite 242 and use a Torque Wrench only to Torque to 90-inch pounds)

TIGHTEN Hex Screw if Locking Tab is not Parallel with Flat on Head (STEP 9)

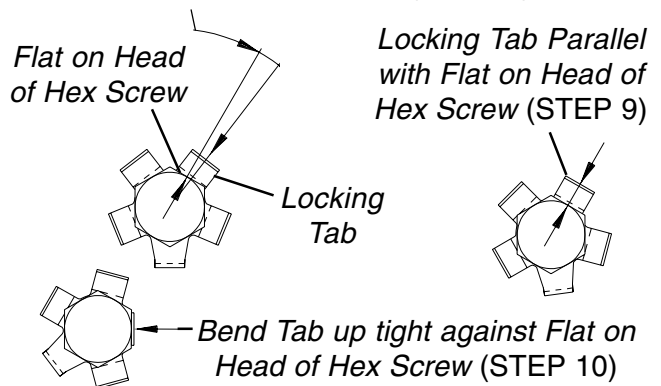

FIGURE 6 - INSTALLING/REPLACING REAR WHEELS

NOTE: Tighten hex screw only. DO NOT loosen hex screw to make one of the tabs on the locking washer parallel.

10. Bend the parallel tab of locking tab washer up tight against flat of the hex screw (FIGURE 6).

INSTALLING/REPLACING FRONT CASTERS (FIGURE 7)

1. Remove the hex screw, spacers and locknut that secure the front caster to the fork.
2. Remove the front caster from the fork.
3. Replace front caster and reverse STEPS 1-2.

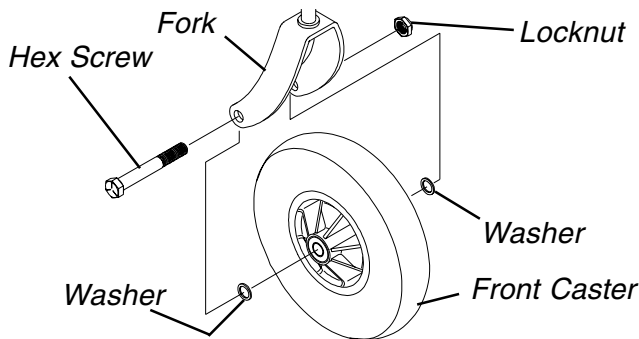

FIGURE 7 - INSTALLING/REPLACING FRONT CASTERS

REPLACING FRONT FORK (FIGURE 8)

1. Remove the front caster assemblies from the front fork. Refer to INSTALLING/REPLACING FRONT CASTERS in this procedure of the manual.
 2. Remove the head tube cap.
 3. Remove the locknut and nylon washer.
 4. Drop the front fork out of the caster head tube.
 5. Slide the new front fork into the caster head tube.
- NOTE: Check bearing assemblies. Replace if necessary.*
6. Make sure front fork is completely in caster head tube.
 7. Install nylon washer and secure with locknut.

WARNING
Improper positioning of the washer will prohibit the free movement of the front forks.

8. Install front caster assemblies onto the front fork. Refer to INSTALLING/REPLACING FRONT CASTERS in this procedure of the manual.
9. To properly tighten caster journal system and guard against flutter, perform the following check:
 - a. Tip front of wheelchair off floor.
 - b. Pivot forks and casters to top of their arc simultaneously.

- c. Let casters drop to bottom of arc (wheels should swing once to one-side, then immediately rest in a straight downward position).
- d. Adjust locknuts according to freedom of caster swing.
- e. Test wheelchair for maneuverability.

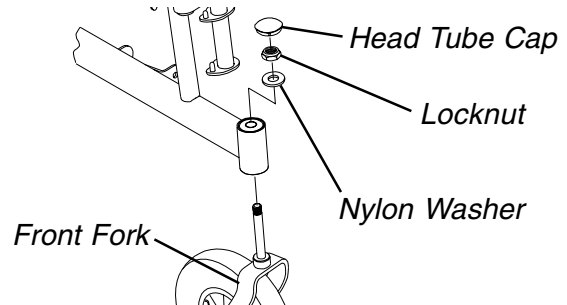

FIGURE 8 - REPLACING FRONT FORK

INSTALLING/REMOVING ANTI-TIPPERS (FIGURE 9)

WARNING
Anti-tippers **MUST** be fully engaged and spring buttons fully protruding out of adjustment holes.

1. Press the release buttons IN and insert the anti-tippers with the anti-tipper wheels pointing toward the ground/floor into the support tubes until the release buttons lock in place.
2. Measure the distance between the bottom of the anti-tipper wheels and the ground/floor.

*NOTE: A 1-1/2 to 2-inch clearance between the bottom of the anti-tipper wheels and the ground/floor **MUST** be maintained at all times.*

3. If the distance between the bottom of the anti-tipper wheels and the ground/floor is not 1/1/2 to 2-inches, do not use the anti-tippers. Replace anti-tippers and repeat STEPS 1 and 2.

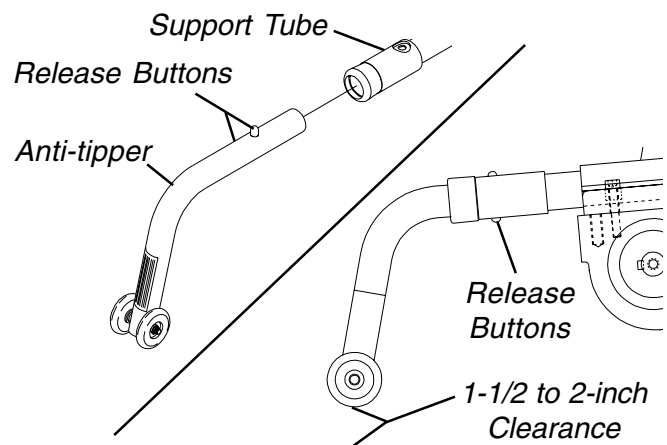

FIGURE 9 - INSTALLING/REMOVING ANTI-TIPPERS

WHEELS / ANTI-TIPPER

INSTALLING OPTIONAL CLUTCH EXTENSION HANDLES - MOTORS WITH CLUTCHES ONLY (FIGURE 10)

1. Turn the power to the wheelchair to the OFF position.
2. Position the clutch extension handle by the clutch handle on the motor as shown in FIGURE 10.

NOTE: If the clutch handle on the motor is equipped with a rubber tip, remove the rubber tip before installing the clutch extension handle.

3. Slide clutch extension handle onto the clutch handle on the motor.

NOTE: If necessary, lightly tap the clutch extension handle onto the clutch handle with a plastic mallet. Make sure the vertical portions of both handles are in line.

4. Securely tighten set screw on clutch extension handle.
5. Repeat STEPS 2-4 for opposite side of wheelchair.

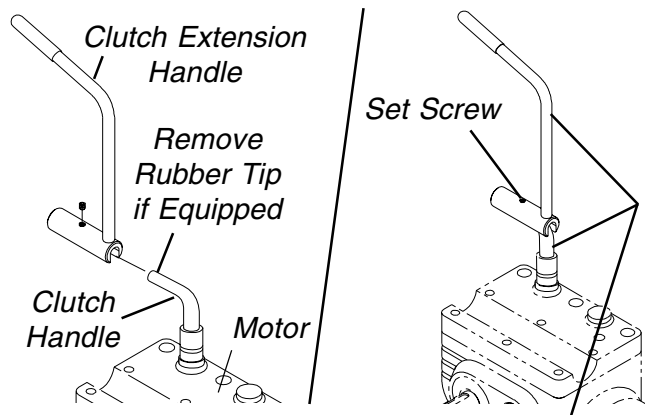

NOTE: Make sure vertical portions of both handles are in line.

FIGURE 10 - INSTALLING OPTIONAL CLUTCH EXTENSION HANDLES - MOTORS WITH CLUTCHES ONLY

This Procedure includes the following:
Replacing Motor/Gearbox

WARNING
 After ANY adjustments, repair or service and BEFORE use, make sure all attaching hardware is tightened securely - otherwise injury or damage may result.

CAUTION
 The longer socket screws must be positioned in the mounting holes on the OUTSIDE of the wheelchair frame and the short socket screws must be in the mounting holes on the INSIDE of the wheelchair frame. Otherwise damage to the gearbox casting can result.

REPLACING MOTOR/GEARBOX (FIGURE 1)

WARNING
 The following procedure should only be performed by a qualified technician.

NOTE: The following procedure can be followed for either BASIC , STANDARD or 250 SERIES motor/gearboxes.

1. Remove the battery boxes. Refer to INSTALLING/REMOVING BATTERY BOXES in PROCEDURE 8 of this manual.
2. Disconnect the right and/or left motor connector from the controller.
3. Remove the rear wheels from the wheelchair. Refer to INSTALLING/REPLACING REAR WHEELS in PROCEDURE 12 of this manual.
4. Remove the six (6) socket screws that secure the motor/gearbox and support tube to the wheelchair frame.
5. Reposition new motor/gearbox on wheelchair frame.
6. Position the support tube between the wheelchair frame and the new motor/gearbox. Make sure the alignment hole in the support tube is positioned with the alignment pin on the motor mount plate.

NOTE: The alignment pin is the longest of the three (3) pins and is located in the center of the wheelchair frame motor mount plate. Refer to DETAIL "A" in FIGURE 1.

NOTE: When the alignment hole in the support tube is positioned with the alignment pin on the wheelchair frame, the anti-tipper wheels should be pointing down towards the ground/floor.

7. Use Loctite 242 and securely tighten the support tube and motor/gearbox to the wheelchair frame with the six (6) socket screws. Torque to 60-inch pounds.
8. Reinstall the rear wheels onto the wheelchair. Refer to INSTALLING/REPLACING REAR WHEELS in PROCEDURE 12 of this manual.
9. Reconnect the right and/or left motor connector to the controller.
10. Repeat procedure for opposite side of the wheelchair, if necessary.
11. Reinstall the battery boxes. Refer to INSTALLING/REMOVING BATTERY BOXES in PROCEDURE 8 of this manual.

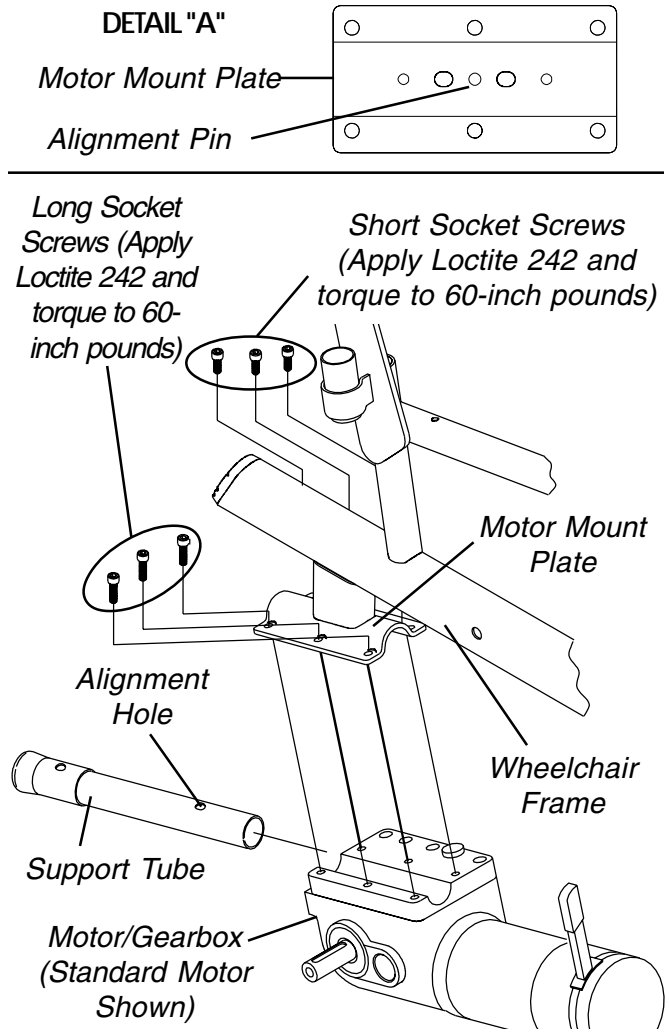

FIGURE 1 - REPLACING MOTOR/GEARBOX

<p><i>This Procedure Includes the Following:</i></p> <p><i>Recliner Operation</i></p> <p><i>Replacing Back or Headrest Upholstery</i></p> <p><i>Adjusting Back or Headrest Upholstery</i></p> <p><i>Replacing Limit Switch/Actuator</i></p> <p><i>Adjusting Limit Switch</i></p> <p><i>Replacing Recliner Cable Assemblies</i></p> <p><i>Replacing/Adjusting Gas Cylinders</i></p> <p><i>Changing Back Height</i></p>
--

3. Stand behind the wheelchair and grasp both back canes firmly.
4. Pull up on the handles of the recliner cable assemblies to release the gas cylinders.
5. **SLOWLY**, push down on the back canes while squeezing the handles of the recliner cable assemblies in a continuous motion.
6. When the back reaches the desired angle, **SLOWLY** let go of the handles of the recliner cable assemblies.
7. To return the back to the full upright position, reverse the above steps keeping in mind proper body mechanics.

RECLINER OPERATION (FIGURE 1)

WARNING

ALWAYS make sure that the wheelchair is stable BEFORE using the recliner option.

NEVER operate the wheelchair while in any recline position over 105° RELATIVE TO THE SEAT FRAME. If the limit switch does not stop the wheelchair from operating in a recline position greater than 105° RELATIVE TO THE SEAT FRAME, do not operate the wheelchair. Adjust the limit switch or have the wheelchair serviced by a dealer or qualified technician.

Both gas cylinders MUST be operational and adjusted properly BEFORE using the recliner. DO NOT operate the recliner option if only one (1) of the gas cylinders is operational or adjusted properly.

TO HEALTHCARE PROFESSIONALS/ASSISTANTS:

Make sure the occupant of the wheelchair is properly positioned.

When returning the occupant of the wheelchair to the full upright position, more body strength will be required for approximately the last twenty (20) degrees of incline (reverse recline). Make sure to use proper body mechanics (use your legs) or seek assistance if necessary to avoid injury.

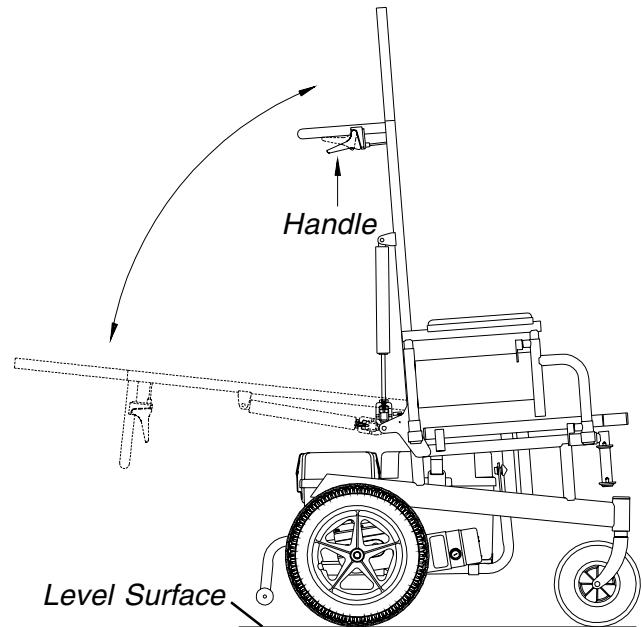

FIGURE 1 - RECLINER OPERATION

1. Make sure the wheelchair is on a level surface.
2. Inform the occupant of the wheelchair that the wheelchair is about to be reclined.

REPLACING BACK OR HEADREST UPHOLSTERY (FIGURE 2)

Replacing Back Upholstery

1. Remove the ten (10) or twelve (12) phillips screws (depending on back height) that secure the back upholstery to the back canes.
2. Remove the existing back upholstery from the back canes.
3. Install the new back upholstery onto the back upholstery.
4. Install the ten (10) or twelve (12) phillips screws (depending on back height) that secure the back upholstery to the recliner back canes.
5. Adjust the back upholstery to the desired tautness. Refer to ADJUSTING BACK OR HEADREST UPHOLSTERY in this procedure of the manual.

NOTE: If the back upholstery HEIGHT is being changed, the back canes must also be changed. Refer to CHANGING BACK HEIGHT in this procedure of the manual.

NOTE: If the back upholstery HEIGHT is being changed, it may be necessary to replace the recliner cable assemblies as well. Refer to REPLACING RECLINER CABLES in this procedure of the manual.

Replacing Headrest Upholstery

1. Remove the six (6) phillips screws that secure the headrest upholstery to the headrest extensions.
2. Remove the existing headrest upholstery from the headrest extensions.
3. Install the new headrest upholstery onto the headrest extensions.
4. Install the six (6) phillips screws that secure the headrest upholstery to the headrest extensions.
5. Adjust the headrest upholstery to the desired tautness. Refer to ADJUSTING BACK OR HEADREST UPHOLSTERY in this procedure of the manual.

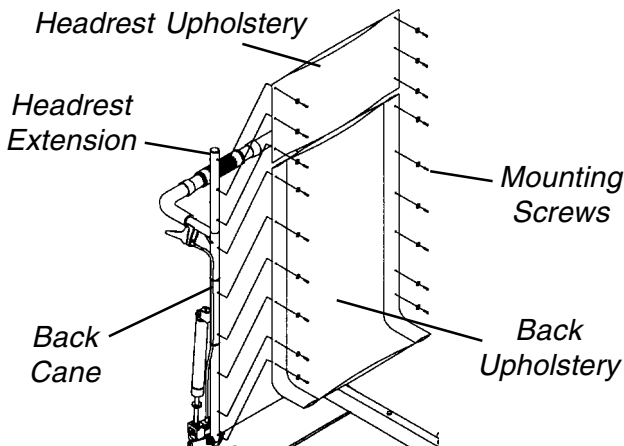

FIGURE 2 - REPLACING BACK OR HEADREST UPHOLSTERY

ADJUSTING BACK OR HEADREST UPHOLSTERY (FIGURE 3)

1. Rotate the spreader bar either:
 - COUNTERCLOCKWISE** (away from back upholstery) to **LOOSEN** back/headrest upholstery
 - OR**
 - CLOCKWISE** (towards back upholstery) to **TIGHTEN** back/headrest upholstery

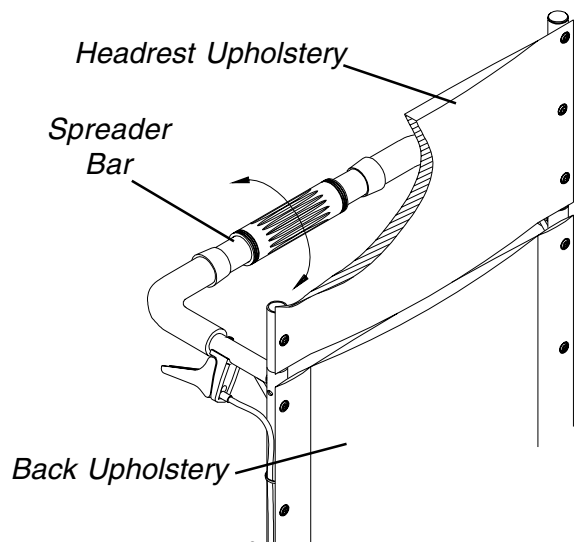

FIGURE 3 - ADJUSTING BACK OR HEADREST UPHOLSTERY

REPLACING LIMIT SWITCH/ACTUATOR (FIGURE 4)

1. Remove nylon boot from motor and battery leads. Refer to DISCONNECTING/CONNECTING MKIV CONTROLLER MOTOR AND BATTERY LEADS in PROCEDURE 9 of this manual.
2. Remove primary portion of wiring harness from controller. Refer to REPLACING WIRING HARNESS in PROCEDURE 11 of this manual.
3. Cut the tie wraps that secure the limit switch wire to the seat frame.
4. Remove the phillips screw that secures the wire retainer to the inside of the seat frame.
5. Remove the two (2) phillips screws and washers that secure the actuator to the gas cylinder pivot block.
6. Remove the two (2) phillips screws and washers that secure the limit switch sensor to the seat frame.
7. Remove main wiring harness and limit switch sensor.

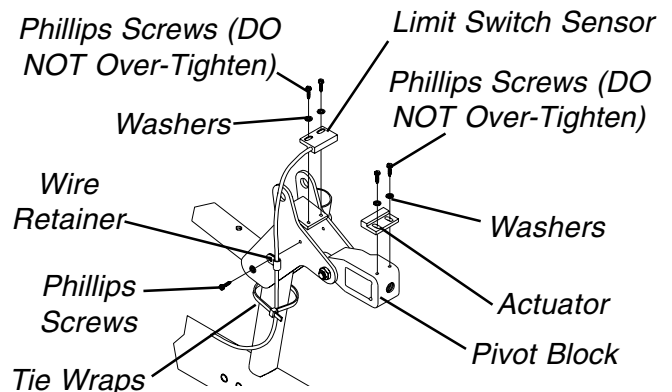

FIGURE 4 - REPLACING LIMIT SWITCH/ACTUATOR

RECLINER

CAUTION

DO NOT over tighten the phillips screws that secure the actuator to the pivot block. Damage to the actuator will occur.

8. Secure the **NEW** actuator to the pivot block with the two (2) phillips screws and washers.

CAUTION

DO NOT over tighten the phillips screws that secure the limit switch to the chair frame. Damage to the limit switch will occur.

9. Position the limit switch sensor onto the seat frame.
10. Secure limit switch sensor to the seat frame with the two (2) phillips screws and washers.
11. Secure the wire retainer onto the **INSIDE** of the seat frame with the phillips screw.
12. Tie wrap the limit switch wire to the seat frame.
13. Reinstall primary portion of wiring harness from controller. Refer to REPLACING WIRING HARNESS in PROCEDURE 11 of this manual.
14. Reinstall nylon boot onto motor and battery leads. Refer to DISCONNECTING/CONNECTING MKIV CONTROLLER MOTOR AND BATTERY LEADS in PROCEDURE 9 of this manual.
15. Adjust the limit switch. Refer to ADJUSTING LIMIT SWITCH in this procedure of the manual.

ADJUSTING LIMIT SWITCH (FIGURE 5)

WARNING

NEVER operate the wheelchair while in any recline position over 105° RELATIVE TO THE SEAT FRAME. If the limit switch does not stop the wheelchair from operating in a recline position greater than 105° RELATIVE TO THE SEAT FRAME, do not operate the wheelchair. Adjust the limit switch or have the wheelchair serviced by a dealer or qualified technician.

1. Recline the back of the wheelchair until the gas cylinder rod measures 3-21/32 of an inch.
2. Turn the power of the joystick to the ON position.

NOTE: ALL segments of the bar graph on the joystick should start to flash on and off and wheelchair should not operate.

3. **IF** the wheelchair operates, proceed to the following steps to adjust the actuator on the pivot block:
 - A. Loosen, but do not remove, the two (2) phillips screws and washers that secure the actuator to the pivot block.
 - B. Slide the actuator UP (towards the top of the wheelchair).

CAUTION

DO NOT over tighten the phillips screws that secure the actuator to the pivot block. Damage to the actuator will occur.

- C. Only tighten the two (2) phillips screws and washers that secure the actuator to the pivot block until the actuator does not move.
- D. Repeat **STEPS 1, 2** and **3** until the wheelchair does not operate when the gas cylinder rod is 3-21/32-inch long.

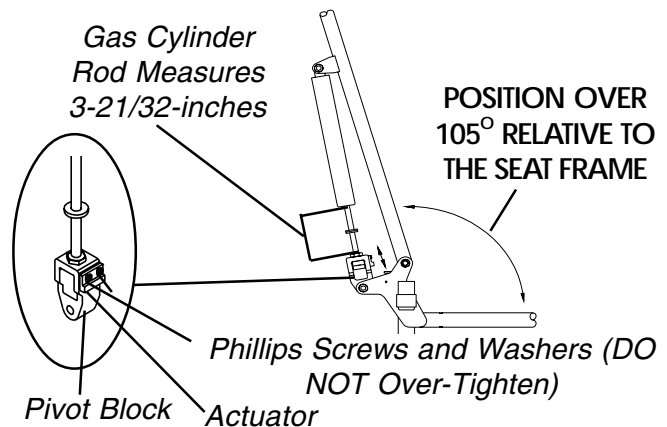

FIGURE 5 - ADJUSTING LIMIT SWITCH

REPLACING RECLINER CABLE ASSEMBLIES (FIGURE 6)

NOTE: There are three (3) different cable lengths depending on back height:

CABLE LENGTH	BACK HEIGHT
Short	18-1/2 and 20-inches
Medium	22 and 24-inches
Long	26-inches

WARNING

Replace **ONE (1)** recliner cable assembly at a time to avoid injury.

1. Cut the tie wraps that secure the existing recliner cable assembly to the back cane.
2. Remove the pan screw that secures the handle of the existing recliner cable assembly to the back cane.
3. Loosen the jam nut on the gas cylinder rod.

4. Remove the socket screw, washer, nylon washers and locknut that secure the TOP of the gas cylinder to the mounting bracket on the back cane.
5. Unscrew the gas cylinder from the operator of the existing recliner cable assembly but do not remove the gas cylinder from the pivot block.
6. Remove the operator of the existing recliner cable assembly from the pivot block.
7. Finger tighten jamnut until it bottoms out on the cylinder rod (FIGURE 6).
8. Screw cylinder rod of the gas cylinder into pivot block until shoulder of shoulder of the cylinder rod is flush with inside of pivot block (FIGURE 6).
9. Position the operator of the recliner cable assembly on the inside of recliner seat frame.
10. Place cable operator into pivot block.
11. Thread cylinder rod into cable operator **ONLY** to the point where there is no slack in cable, no angular movement in cable operator, and recliner cable operator assembly is no more than a space equal to or less than 1/16-inch away from pivot block (FIGURE 6).
12. Visually inspect the trigger assembly to ensure that the cable fitting is seated properly in the trigger assembly and that cable end is completely snapped down into slot (FIGURE 6).
13. Line up the mounting holes of the gas cylinder and the bracket of the back cane.
14. Reinstall the socket screw through the mounting bracket of the back cane, nylon washer, gas cylinder, nylon washer, mounting bracket and washer and securely tighten with the existing locknut. **Torque to 75-inch pounds.**
15. Adjust the gas cylinders. Refer to ADJUSTING GAS CYLINDERS in this procedure of the manual.

CAUTION

DO NOT force the gas cylinder rod into the operator of the recliner cable assembly.

DO NOT cross thread the operator of the recliner cable assembly with the gas cylinder.

If a space EQUAL to or LESS THAN 1/16-inch between the operator of the cable assembly and the pivot block is not obtainable, DO NOT use the recliner cable assembly.

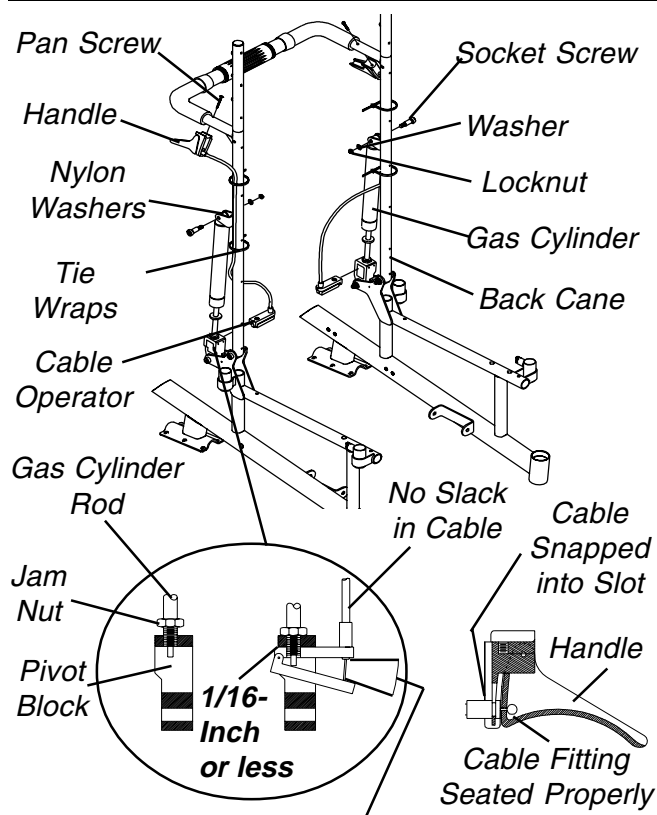

NO Angular Movement in Operator of the Recliner Cable Assembly

FIGURE 6 - REPLACING RECLINER CABLE ASSEMBLIES

REPLACING/ADJUSTING GAS CYLINDERS (FIGURE 7)

WARNING

Replace ONE (1) gas cylinder at a time to avoid injury.

Both gas cylinders **MUST** be operational and adjusted properly **BEFORE** using the recliner. **DO NOT** operate the recliner if only one (1) of the gas cylinders is operational or adjusted properly.

Replacing Gas Cylinder

1. Loosen the jam nut on existing gas cylinder rod.
2. Remove the socket screw, washer, nylon washers and locknut that secure the **TOP** of the gas cylinder to mounting bracket on back cane.
3. Unscrew the existing gas cylinder from the operator of the recliner cable assembly and the pivot block and remove the existing gas cylinder from the wheelchair.
4. Finger tighten jamnut on **NEW** gas cylinder until it bottoms out on the cylinder rod (FIGURE 7).
5. Screw the cylinder rod of the new gas cylinder into the pivot block until the shoulder of the cylinder rod is flush with the inside of the pivot block (FIGURE 7).

CAUTION

DO NOT force the gas cylinder rod into the operator of the recliner cable assembly.

DO NOT cross thread the operator of the recliner cable assembly with the gas cylinder.

If a space EQUAL to or LESS THAN 1/16-inch between the operator of the cable assembly and the pivot block is not obtainable, DO NOT use the recliner cable assembly.

6. Position the operator of the recliner cable assembly on the inside of the recliner seat frame.
7. Place cable operator into pivot block.
8. Thread cylinder rod into cable operator **ONLY** to the point where there is no slack in cable, no angular movement in cable operator, and recliner cable operator assembly is no more than a space equal to or less than 1/16-inch away from pivot block (FIGURE 7).
9. Visually inspect the trigger assembly to ensure that the cable fitting is seated properly in the trigger assembly and that cable end is completely snapped down into slot (FIGURE 7).
10. Press the operator of the recliner cable assembly to extend the new gas cylinder.

11. Line up the mounting holes of the new gas cylinder and the bracket of the back cane.
12. Reinstall the socket screw through the mounting bracket of the back cane, nylon washer, new gas cylinder, nylon washer, mounting bracket and washer and securely tighten with the existing locknut. **Torque to 75-inch pounds.**
13. Adjust the new gas cylinders. Refer to ADJUSTING GAS CYLINDERS in this procedure of the manual.

Adjusting Gas Cylinder

1. To adjust the **LEFT** gas cylinder:
Squeeze the handle of the **RIGHT** recliner cable assembly and try to recline the back. The back should not recline.
2. If the **LEFT** side of the back releases without squeezing the handle of the **LEFT** recliner cable assembly, perform the following steps:
 - A. Finger tighten the jam nut on the rod of the gas cylinder until it bottoms out on the rod of the cylinder (FIGURE 7).
 - B. Turn the jam nut on the **LEFT** gas cylinder **COUNTERCLOCKWISE** approximately one-half (1/2) revolution.

NOTE: The gas cylinder rod will turn.

- C. Repeat STEP 1.
- D. Repeat STEP B until the **LEFT** side of the back **DOES NOT** recline.
3. To adjust the **RIGHT** gas cylinder:
Repeat **STEPS 1** and **2** for the **LEFT** handle of the cable assembly.

CAUTION

Damage to the gas cylinder rod WILL occur if the following steps are NOT followed when the jam nut is torqued against the pivot block.

4. Using **NO LARGER** than 1/4-inch wide, fine toothed pliers, wrap masking tape around the teeth of the pliers two (2) or (3) revolutions.
5. Using **NO** excessive force, hold the gas cylinder rod just above the jam nut.
6. While holding the gas cylinder rod and using a 17mm wrench, turn the jam nut **CLOCKWISE** and torque the **RIGHT** and **LEFT** jam nuts against the **RIGHT** and **LEFT** pivot blocks to **13 ft. lbs.**

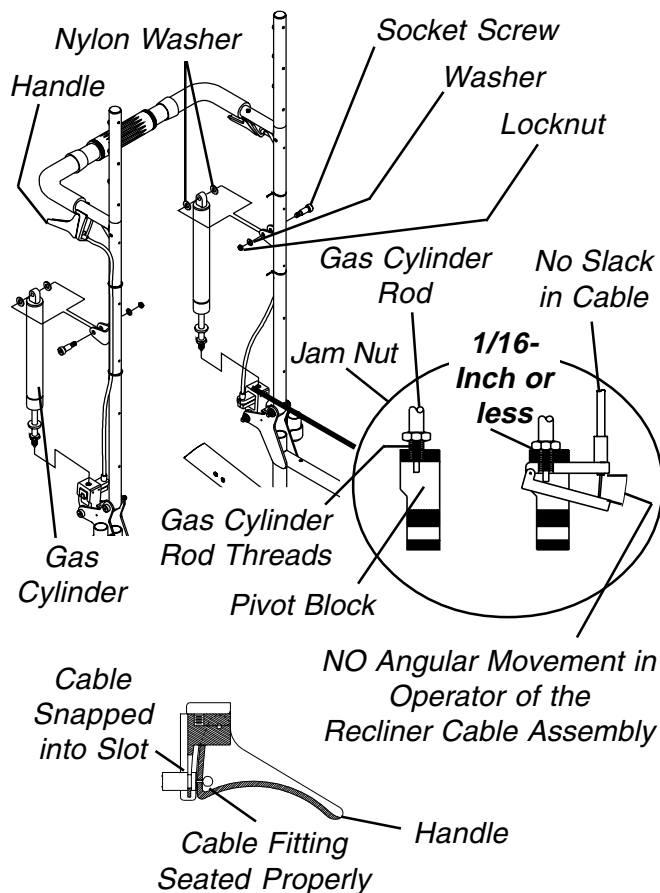

FIGURE 7 - REPLACING/ADJUSTING GAS CYLINDERS

CHANGING BACK HEIGHT (FIGURE 8)

1. Press the push pins on the headrest extension tubes in and remove the headrest extension from the back canes.
2. Remove the existing recliner back upholstery from the wheelchair. Refer to REPLACING BACK OR HEADREST UPHOLSTERY in this procedure of the manual.
3. Remove the recliner cables from the back canes. Refer to REPLACING RECLINER CABLE ASSEMBLIES in this procedure of the manual.
4. Remove the shoulder screws, washers and locknuts that secure the **TOP** of the gas cylinders to the back canes.
5. Remove the shoulder screws, washers and locknuts that secure the back canes to the seat frame.
6. Turn the spreader bar on the existing back canes **CLOCKWISE** (toward back upholstery) and remove the spreader bar from the existing back canes.
7. Thread spreader bar onto the new back cane handles by rotating the spreader bar **COUNTERCLOCKWISE** (away from the back canes).

NOTE: If the spreader bar does not thread onto the back canes, do not force. Turn the spreader bar around and repeat STEP 7.

8. Line up the two (2) bottom mounting holes of the back canes with the two (2) mounting holes in the seat frame.

WARNING

The back canes **MUST** be fastened securely to the seat frame **BEFORE** using the wheelchair. Torque to 13 ft. lbs.

9. Reinstall the shoulder screw, washer and locknut through the back cane and seat frame mounting holes.
10. **Torque to 13 ft. lbs.**
11. Reinstall the shoulder screw through the mounting bracket of the back cane, nylon washer, mounting hole in the **TOP** of the gas cylinder, nylon washer, mounting bracket and washer.
12. Securely tighten with the existing locknut.
13. **Torque to 75-inch pounds.**
14. Reinstall the recliner cable assemblies onto the back canes. Refer to REPLACING RECLINER CABLE ASSEMBLIES in this procedure of the manual.

NOTE: There are three (3) different cable lengths depending on back height:

CABLE LENGTH	BACK HEIGHT
Short	18-1/2 and 20-inches
Medium	22 and 24-inches
Long	26-inches

NOTE: New recliner cables will be needed if the back height is changed to a height not within the length of the original cable.

15. Install the new back upholstery onto the back canes. Refer to REPLACING BACK OR HEADREST UPHOLSTERY in this procedure of the manual.
16. Reinstall the headrest extension onto the recliner back canes.
17. Adjust the tautness of the back and headrest upholstery. Refer to ADJUSTING BACK OR HEADREST UPHOLSTERY in this procedure of the manual.

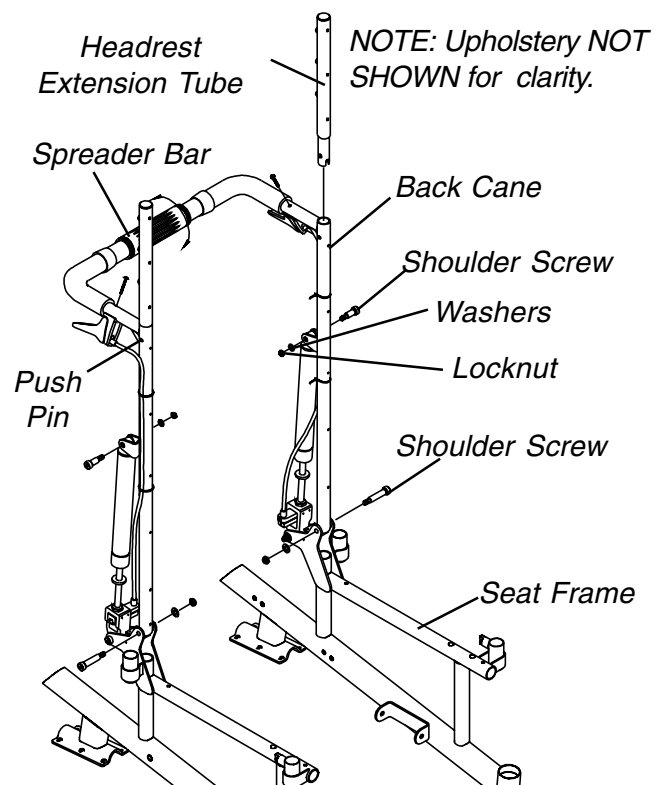

FIGURE 8 - CHANGING BACK HEIGHT

LIMITED WARRANTY

PLEASE NOTE: THE WARRANTY BELOW HAS BEEN DRAFTED TO COMPLY WITH FEDERAL LAW APPLICABLE TO PRODUCTS MANUFACTURED AFTER JULY 4, 1975.

This warranty is extended only to the original purchaser/user of our products.

This warranty gives you specific legal rights and you may also have other legal rights which vary from state to state.

With regards to the original purchaser/user only, Invacare warrants the side frames and crossbraces to be free from defects in materials and workmanship for a period of five (5) years from date of purchase; electronics for a period of one (1) year from the date of purchase; motors and gearboxes for a period of eighteen (18) months for Ranger II models with motors that have motor locks and a period of twelve (12) months for Ranger II models with motors that have clutches from the date of purchase; all remaining components (including gas cylinders for recliners) for one (1) year from the date of purchase except upholstered materials, padded materials and tires/wheels. If within such warranty period any product shall be proven to be defective, such product shall be repaired or replaced, at Invacare's option. This warranty does not include any labor or shipping charges incurred in replacement part installation or repair of any such product. Invacare's sole obligation and your exclusive remedy under this warranty shall be limited to such repair and/or replacement.

For warranty service, please contact the dealer from whom you purchased your Invacare product. In the event you do not receive satisfactory warranty service, please write directly to Invacare at the address at the bottom of this page. Provide dealer's name, address, date of purchase, indicate nature of the defect and, if the product is serialized, indicate the serial number. Do not return products to our factory without our prior consent.

LIMITATIONS AND EXCLUSIONS: THE FOREGOING WARRANTY SHALL NOT APPLY TO SERIAL NUMBERED PRODUCTS IF THE SERIAL NUMBER HAS BEEN REMOVED OR DEFACED, PRODUCTS SUBJECT TO NEGLIGENCE, ACCIDENT, IMPROPER OPERATION, MAINTENANCE OR STORAGE, COMMERCIAL OR INSTITUTIONAL USE, PRODUCTS MODIFIED WITHOUT INVACARE'S EXPRESS WRITTEN CONSENT (INCLUDING, BUT NOT LIMITED TO, MODIFICATION THROUGH THE USE OF UNAUTHORIZED PARTS OR ATTACHMENTS; PRODUCTS DAMAGED BY REASON OF REPAIRS MADE TO ANY COMPONENT WITHOUT THE SPECIFIC CONSENT OF INVACARE, OR TO A PRODUCT DAMAGED BY CIRCUMSTANCES BEYOND INVACARE'S CONTROL, AND SUCH EVALUATION WILL BE SOLELY DETERMINED BY INVACARE. THE WARRANTY SHALL NOT APPLY TO PROBLEMS ARISING FROM NORMAL WEAR OR FAILURE TO ADHERE TO THESE INSTRUCTIONS.

THE FOREGOING WARRANTY IS EXCLUSIVE AND IN LIEU OF ALL OTHER EXPRESS WARRANTIES. IMPLIED WARRANTIES, IF ANY, INCLUDING THE IMPLIED WARRANTIES OF MERCHANTABILITY AND FITNESS FOR A PARTICULAR PURPOSE, SHALL NOT EXTEND BEYOND THE DURATION OF THE EXPRESSED WARRANTY PROVIDED HEREIN AND THE REMEDY FOR VIOLATIONS OF ANY IMPLIED WARRANTY SHALL BE LIMITED TO REPAIR OR REPLACEMENT OF THE DEFECTIVE PRODUCT PURSUANT TO THE TERMS CONTAINED HEREIN. INVACARE SHALL NOT BE LIABLE FOR ANY CONSEQUENTIAL OR INCIDENTAL DAMAGES WHATSOEVER. THIS WARRANTY SHALL BE EXTENDED TO COMPLY WITH STATE/PROVINCIAL LAWS AND REQUIREMENTS.

Invacare Corporation

www.invacare.com



Yes, you can.™

USA
One Invacare Way
Elyria, Ohio USA
44036-2125
800-333-6900

Canada
5970 Chedworth Way
Mississauga, Ontario
L5R 3T9, Canada
905-890-8838

Invacare is a registered trademark of Invacare Corporation.

© 2000 Invacare Corporation
Form No. 95-148

Part No. 1058610

Rev K (2) - 9/00