

On Chair Mounting Kit



Assembly, Installation and Operating Instructions

Model Nos. OCMK01 and OCMK78

Yes, you can.™

SAVE THESE INSTRUCTIONS

NOTE: Check all parts for shipping damage. In case of damage, DO NOT use. Contact Carrier/Invacare for further instruction.

SAFETY SUMMARY

To ensure the safe installation of the On Chair Mounting Kit for the ContourU seating system, these instructions must be followed:

GENERAL WARNINGS

DO NOT install this equipment without first reading and understanding this instruction sheet. If you are unable to understand the **Warnings, Cautions and Instructions**, contact a healthcare professional, dealer or technical personnel if applicable before attempting to install this equipment - otherwise, injury or damage may occur.

Unless otherwise noted, installation and adjustments should be made while the wheelchair is unoccupied

INSTALLATION WARNINGS

The position of the On Chair Mounting Kit in the different mounting bracket configurations is directly related to the chair's stability. When the On Chair Mounting Kit is installed on a **TILT** and/or **RECLINING** wheelchair, the wheelchair's stability may decrease. It may be necessary to reposition the **FRONT CASTERS, REAR WHEELS, BACK ANGLE, TILT-IN-SPACE, RECLINE POSITION** and/or **SEAT DEPTH** before use. Refer to appropriate wheelchair owner's manual. Use **EXTREME** caution when using a new seating position.

Before final tightening, ensure that the brackets will not interfere with the operation of the wheelchair, or be in a position to injure the patient or any attendant.

After **ANY** adjustments, repair or service and **BEFORE** use, make sure that all attaching hardware is tightened securely.

USER WARNINGS

Skin condition should be checked frequently after the installation of any new seating system.

Your therapist and physician should be consulted if you have any questions regarding individual limitations and needs.

Working with your therapist, physician, and rehabilitation technology supplier is the best way to assure that the ContourU seating system choice matches your individual needs.

As the needs of the individual become more complex, the ContourU seating system evaluation becomes more important.

IMPORTANT INFORMATION

The best way to avoid problems related to pressure sores is to understand their causes and your role in a skin management program.

Your therapist and physician should be consulted if you have questions regarding individual limitations and needs.

All seats and/or backs should be selected carefully. Working with your therapist, and physician is the best way to assure that a seat choice matches your individual needs.

As the needs of the individual become more complex, the seat evaluation becomes more important.

INSTALLATION INFORMATION:

Before you install the On Chair Mounting Kit, determine where the ContourU back cushion must be placed in relation to the seat cushion. Find the appropriate recline angle and seat depth, and estimate where the clamps will be mounted. Remove any obstacles on the wheelchair back canes and seat rails that might interfere with installation.

The adjustable mounting brackets can be placed in different configurations. It is important to determine first where the ContourU seating system will be placed in relation to the wheelchair frame.

To maintain the original center of gravity (CG) of the wheelchair user, the ContourU back will normally be placed between or behind the back uprights.

INSTALLATION OF THE ON CHAIR MOUNTING KIT BACK MOUNTING HARDWARE (FIGURE 1)

NOTE: Refer to GENERAL and INSTALLATION WARNINGS in the SAFETY SUMMARY in this instruction sheet.

NOTE: The wheelchair hardware consists of two (2) fixed release clamps and two (2) twist release clamps. The wheelchair hardware must be mounted facing forward (in front of the canes) with the twist release clamps at the top and the fixed release clamps at the bottom.

NOTE: The back mounting brackets should be placed on the back cane without interfering with other wheelchair parts or accessories.

1. Install the four (4) L brackets to the ContourU back. Refer to INSTALLING THE BACK L BRACKETS in this procedure of the instruction sheet.
2. Install the J brackets onto the L brackets. Refer to INSTALLING/ADJUSTING THE BACK J BRACKETS in this instruction sheet.
3. Position the back onto the back canes in the desired location.
4. On the back cane, mark the bottom edge of the two (2) lower J brackets and the top edge of the two (2) upper J brackets as shown in DETAIL "A" of FIGURE 1.
5. Remove the mounting screw, washer, lock washer, and internal threaded mounting screw from one of the fixed release clamps.

6. Install the fixed release clamp onto the back cane so that the fixed release clamp is facing the front of the wheelchair and the bottom edge is aligned with the mark made in STEP 4 as shown in DETAIL "B" of FIGURE I.
7. Using the mounting screw, washer, lock washer, and internal threaded mounting screw, secure the fixed release clamp to the back cane. Securely tighten.
8. Repeat STEPS 5-6 to install remaining fixed release clamp.
9. Remove the mounting screw, washer, lock washer, and internal threaded mounting screw from one of the twist release clamps.
10. Install the twist release clamp onto the back cane so that the twist release clamp is facing the front of the wheelchair and the top edge is aligned with the mark made in STEP 4 as shown in DETAIL "B" of FIGURE I.
11. Using the mounting screw, washer, lock washer, and internal threaded mounting screw, secure the fixed release clamp to the back cane. Securely tighten.
12. Repeat STEPS 8-9 to install remaining twist release clamp.
13. Install the ContourU back onto the chair. Refer to INSTALLING/REMOVING THE CONTOUR U SEATING SYSTEM BACK in this instruction sheet.
14. If back depth and or angle adjustments are necessary refer to ADJUSTING THE CONTOUR U SEATING SYSTEM BACK in this instruction sheet.

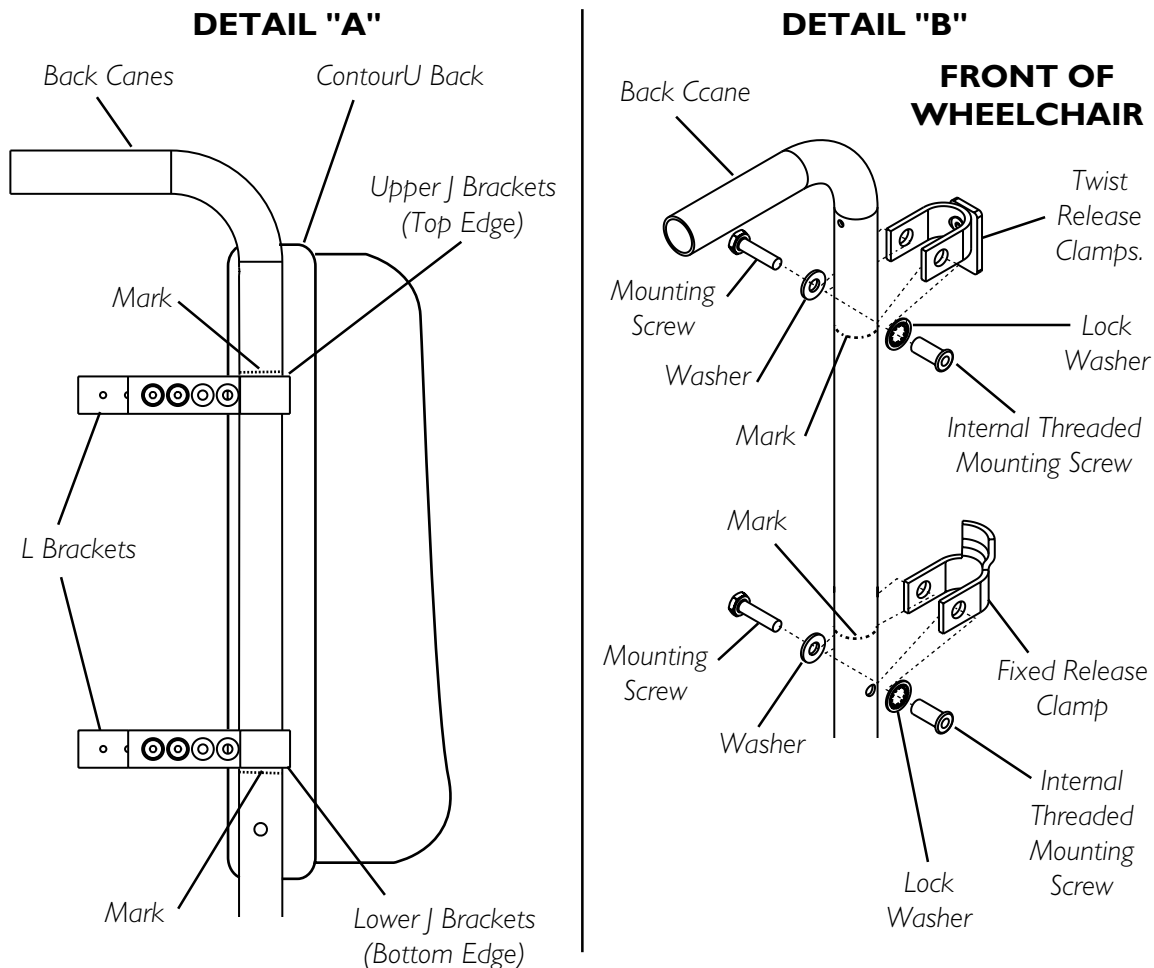

FIGURE I - INSTALLATION OF THE ON CHAIR MOUNTING KIT BACK MOUNTING HARDWARE

INSTALLING THE BACK L BRACKETS (FIGURE 2)

NOTE: When mounting the L brackets to the wood backed ContourU cushion the L brackets may be reversed to allow for greater seat depth adjustments as shown in DETAIL "A" of FIGURE 2.

1. Position the ContourU Back between the back canes and determine the mounting positions for the four (4) L brackets to obtain the desired back depth.
2. If mounting L bracket to a pan back, pull to remove the ContourU cushion from the pan back.
3. Align L bracket with the edge of the seat back and two (2) desired mounting holes as shown in FIGURE 1.
4. Perform one (1) of the following:
 - A. PAN BACK: Using a backing plate and two (2) mounting screws, secure the L bracket to the pan back.
 - B. WOOD BACK: using two (2) mounting screws secure the L bracket to the wood back.
5. Repeat STEPS 3-4 for remaining three (3) L brackets.
6. If mounting L bracket to a pan back, reinstall the ContourU cushion onto the back pan.

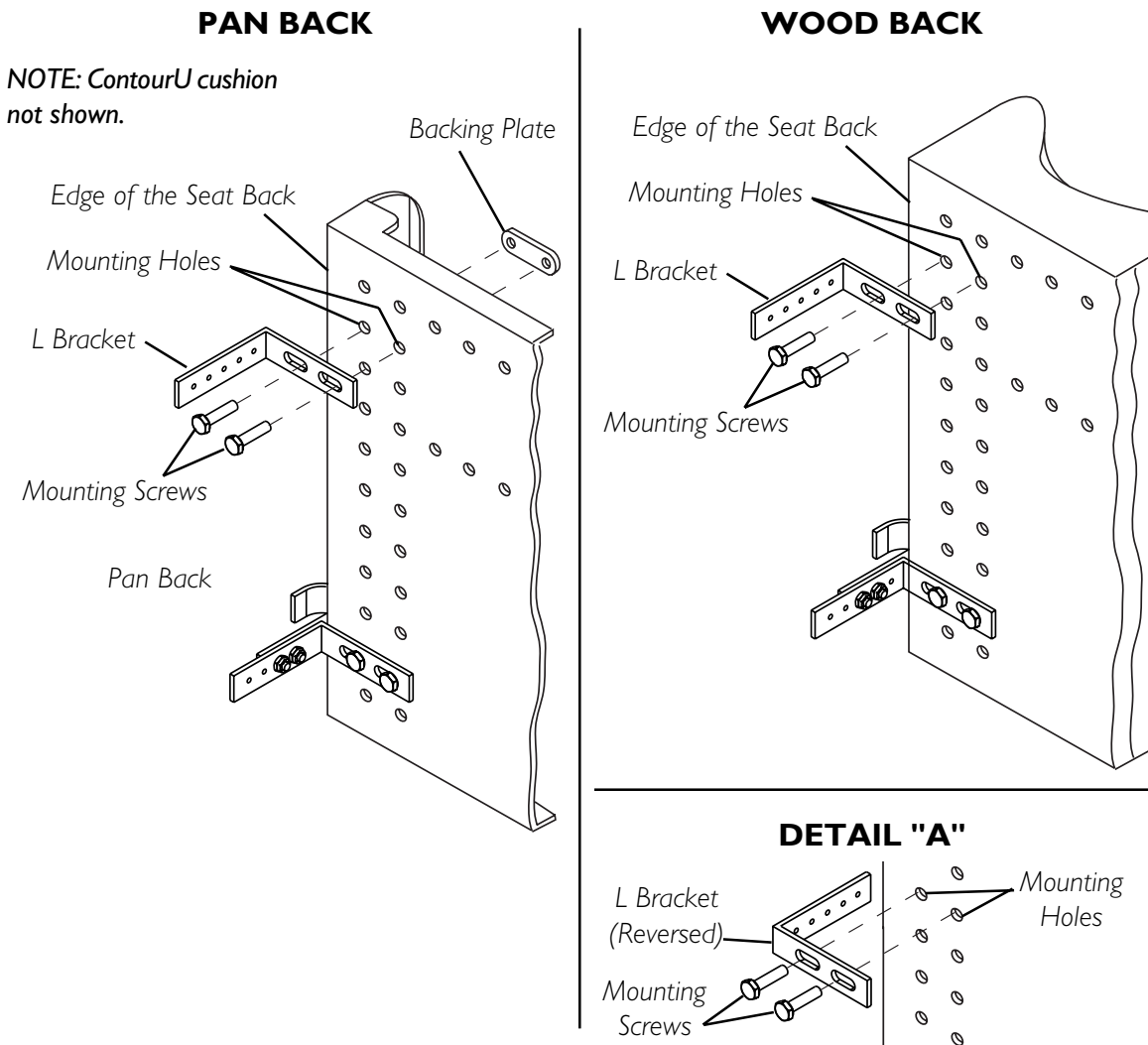

FIGURE 2 - INSTALLING THE BACK L BRACKETS

INSTALLING THE BACK J BRACKETS (FIGURE 3)

1. Position the ContourU back between the back canes to determine the approximate mounting position of the J brackets to obtain the desired depth.
2. Align two (2) of four (4) mounting holes of the J bracket with two (2) of five (5) mounting holes on the L bracket as shown in FIGURE 3.
3. Using two (2) mounting screws and locknuts, secure the J bracket to the L bracket. Securely tighten mounting hardware.
4. Repeat STEPS 2-3 with three (3) remaining brackets.

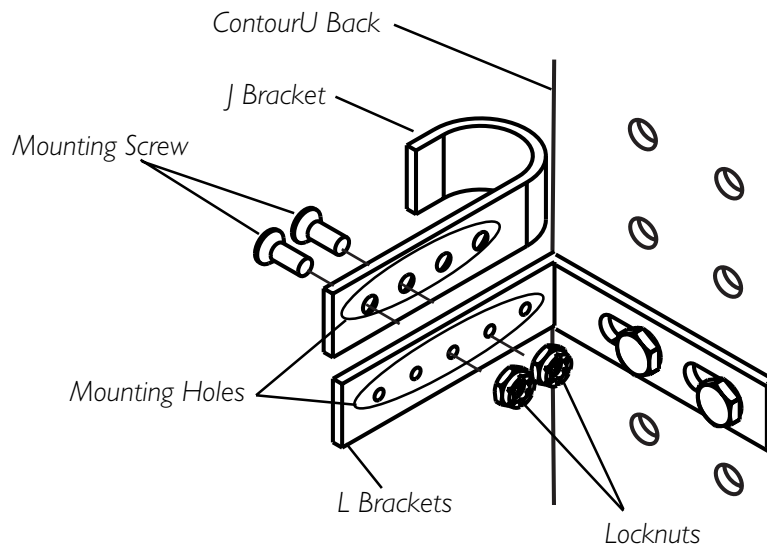

FIGURE 3 - INSTALLING THE BACK J BRACKETS

INSTALLING/REMOVING THE CONTOUR U SEATING SYSTEM BACK (FIGURE 4)

Installing

1. Ensure that the twist release clamps are in the OPEN position as shown in DETAIL "A" of FIGURE 4.
2. Position the two (2) lower J brackets securely into the two (2) fixed release clamps as shown in FIGURE 4.
3. Position the upper two (2) J brackets against the back canes just below the two (2) twist release clamp.
4. Rotate the two (2) twist release clamps to the CLOSED position as shown in DETAIL "B" of FIGURE 4.

Removing

1. Rotate the two (2) twist release clamps to the OPEN position as shown in DETAIL "B" of FIGURE 4.
2. tilt the top of the ContourU back forward away from the back canes.
3. Pulling UP, remove the ContourU back from the back canes.

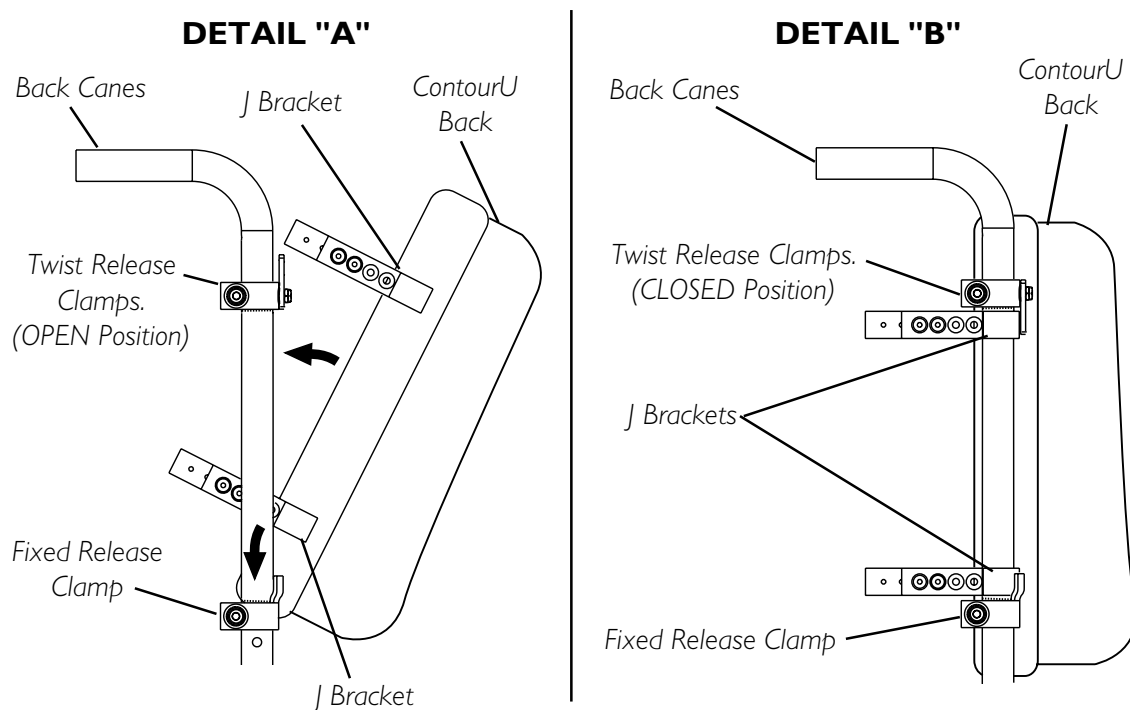

FIGURE 4 - INSTALLING/REMOVING THE CONTOUR U BACK

ADJUSTING THE ON CHAIR MOUNTING KIT MOUNTING HARDWARE FOR THE CONTOUR U SEATING SYSTEM BACK

NOTE: Refer to GENERAL and INSTALLATION WARNINGS in the SAFETY SUMMARY in this instruction sheet.

ADJUSTING THE CONTOUR U BACK DEPTH (FIGURE 5)

NOTE: There are six (6) depth adjustments available on the ContourU with a pan back.

NOTE: There are twelve (12) depth adjustments available on the ContourU with a wood back. Six (6) mounting positions with the L brackets facing the front of the wheel chair and six (6) mounting positions with the L brackets facing the rear of the wheel chair as shown in FIGURE 5.

NOTE: All four (4) J brackets should be adjusted to the same depth unless back angle adjustment is necessary. Refer to ADJUSTING THE CONTOUR U SEATING SYSTEM BACK ANGLE in this instruction sheet after performing this procedure.

1. If necessary, remove the ContourU back. Refer to INSTALLING/REMOVING THE CONTOUR U SEATING SYSTEM BACK in this instruction sheet.
2. Remove the two (2) mounting screws and locknuts that secure the J bracket to the L bracket.
3. Align two (2) mounting holes of the J bracket with two (2) mounting holes of the L bracket to acquire the desired depth as shown in DETAIL "A" of FIGURE 5 .
4. Reinstall the two (2) mounting screws and locknuts that secure the J bracket to the L bracket. Securely tighten.
5. Repeat STEPS 3-4 to adjust the remaining three (3) J and L brackets.
6. Reinstall the ContourU back onto the wheelchair. Refer to REMOVING/INSTALLING THE CONTOUR U SEATING SYSTEM BACK in this instruction sheet.
7. Ensure the ContourU back is set to the desired depth. If necessary repeat STEPS 1-7 until desired depth is achieved.

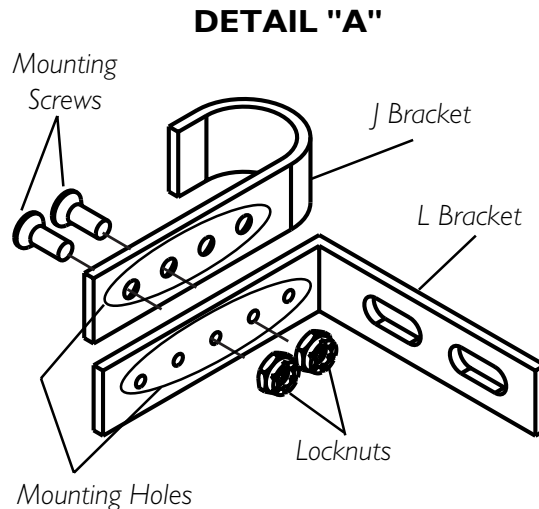

DEPTH ADJUSTMENTS

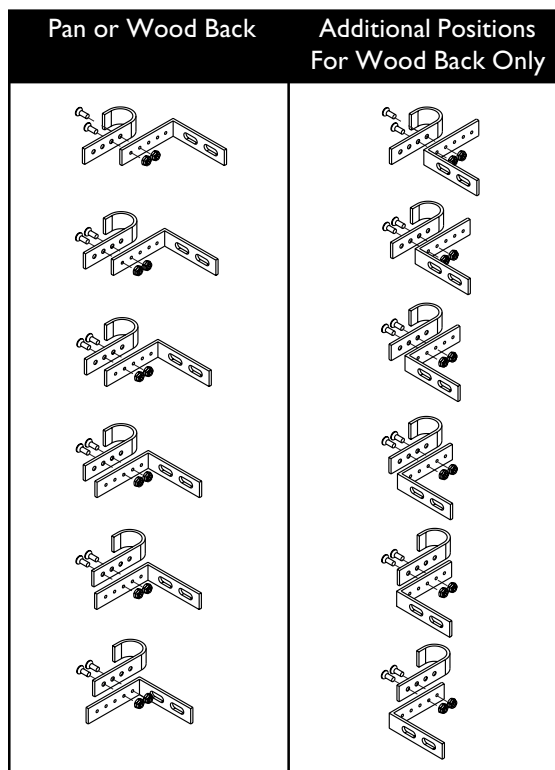

FIGURE 5 - ADJUSTING THE CONTOUR U SEATING SYSTEM BACK DEPTH

ADJUSTING THE CONTOUR U SEATING SYSTEM BACK ANGLE (FIGURE 6)

NOTE: Before performing this procedure all four (4) J brackets must be adjusted to the same depth. Refer to ADJUSTING THE CONTOUR U SEATING SYSTEM BACK DEPTH in this instruction sheet.

NOTE: The back to seat angle is adjusted by repositioning the top and/or the bottom J brackets.

NOTE: Adjustments made to J bracket(s) on one side of the ContourU back MUST be also be made to the remaining J bracket(s) on the opposite side of the ContourU back.

1. If necessary, install the ContourU back. Refer to REMOVING/INSTALLING THE CONTOUR U SEATING SYSTEM BACK in this instruction sheet.
2. With the ContourU back installed on the wheelchair, determine which J bracket mounting positions are necessary to achieve the desired back angle adjustment.
3. Remove the ContourU back. Refer to REMOVING/INSTALLING THE CONTOUR U SEATING SYSTEM BACK in this instruction sheet.
4. Remove the two (2) mounting screws and locknuts that secure the J bracket to the L bracket as shown in DETAIL "A" of FIGURE 6.
5. Align two (2) mounting holes of the J bracket with two (2) mounting holes of the L bracket to acquire the desired angle.
6. Reinstall the two (2) mounting screws and locknuts that secure the J bracket to the L bracket. Securely tighten.
7. Repeat STEPS 4-6 to adjust the remaining J and L brackets as necessary to achieve the desired back angle.
8. Reinstall the ContourU back onto the wheelchair. Refer to REMOVING/INSTALLING THE CONTOUR U SEATING SYSTEM BACK in this instruction sheet.
9. Ensure the ContourU back is set to the desired angle and does not interfere. If necessary repeat STEPS 1-7 until desired depth is achieved.

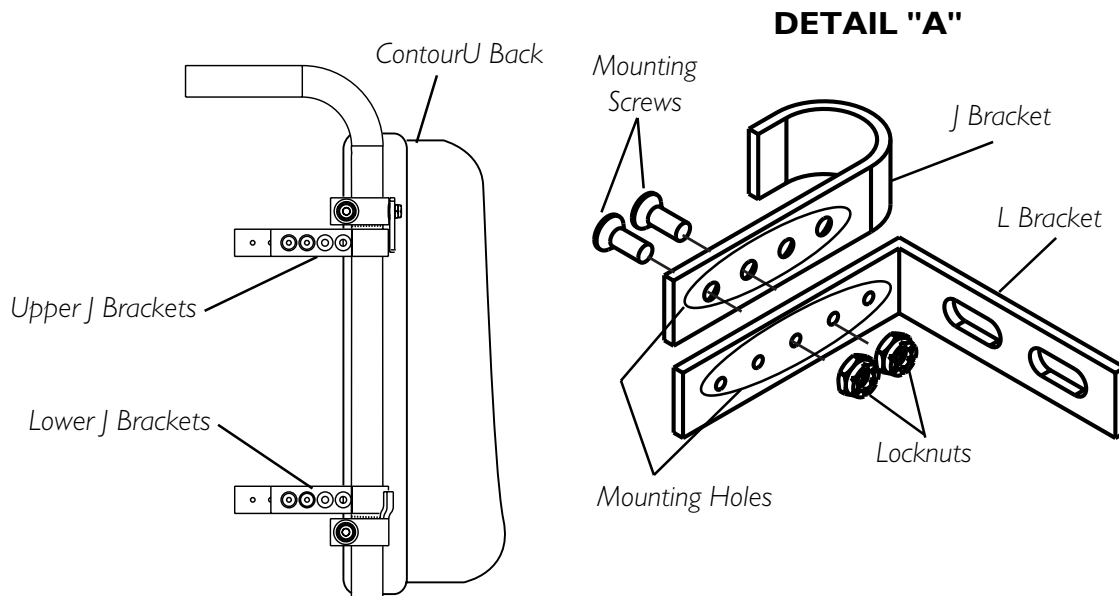

FIGURE 6 - ADJUSTING THE CONTOUR U SEATING SYSTEM BACK ANGLE

INSTALLATION OF ON CHAIR MOUNTING KIT SEAT MOUNTING HARDWARE (FIGURE 7)

NOTE: Refer to GENERAL and INSTALLATION WARNINGS in the SAFETY SUMMARY in this instruction sheet.

NOTE: The wheelchair hardware consists of two (2) fixed release clamps and two (2) twist release clamps. The wheelchair hardware must be mounted facing up (on top of the seat rails) with the twist release clamps at the front and the fixed release at the rear of the seat rails.

NOTE: The seat mounting brackets should be placed on the seat rail without interfering with other wheelchair accessories.

1. Install the L brackets onto the ContourU seat. Refer to INSTALLING THE SEAT L BRACKETS in this instruction sheet.
2. Install the J brackets onto the L brackets. Refer to INSTALLING/ADJUSTING THE SEAT J BRACKETS in this instruction sheet.
3. Position the ContourU seat onto the seat rails in the desired location.
4. On the seat rails, mark the front edge of the two (2) front J brackets and the rear edge of the two (2) rear J brackets as shown in DETAIL "A" of FIGURE 7.
5. Remove the mounting screw, washer, lock washer, and internal threaded mounting screw from one of the fixed release clamps.
6. Install the fixed release clamp onto the seat rail so that the open end of the fixed release clamp is facing the front of the wheelchair and aligned with the mark made in STEP 4 as shown in DETAIL "B" of FIGURE 7.
7. Using the mounting screw, washer, lock washer, and internal threaded mounting screw, secure the fixed release clamp to the seat rail. Securely tighten.
8. Repeat STEPS 5-6 to install remaining fixed release clamp.
9. Remove the mounting screw, washer, lock washer, and internal threaded mounting screw from one of the twist release clamps.
10. Install the twist release clamp onto the seat rail so that open end of the twist release clamp is facing the rear of the wheelchair and is aligned with the mark made in STEP 4 as shown in DETAIL "B" of FIGURE 7.
11. Using the mounting screw, washer, lock washer, and internal threaded mounting screw, secure the twist release clamp to the back cane. Securely tighten.
12. Repeat STEPS 8-9 to install remaining twist release clamp.
13. Install the ContourU seat on to the wheelchair. Refer to INSTALLING/REMOVING THE CONTOUR U SEATING SYSTEM SEAT in this instruction sheet.
14. If seat depth and or angle adjustments are necessary refer to ADJUSTING THE CONTOUR U SEATING SYSTEM SEAT in this instruction sheet.

DETAIL "A"

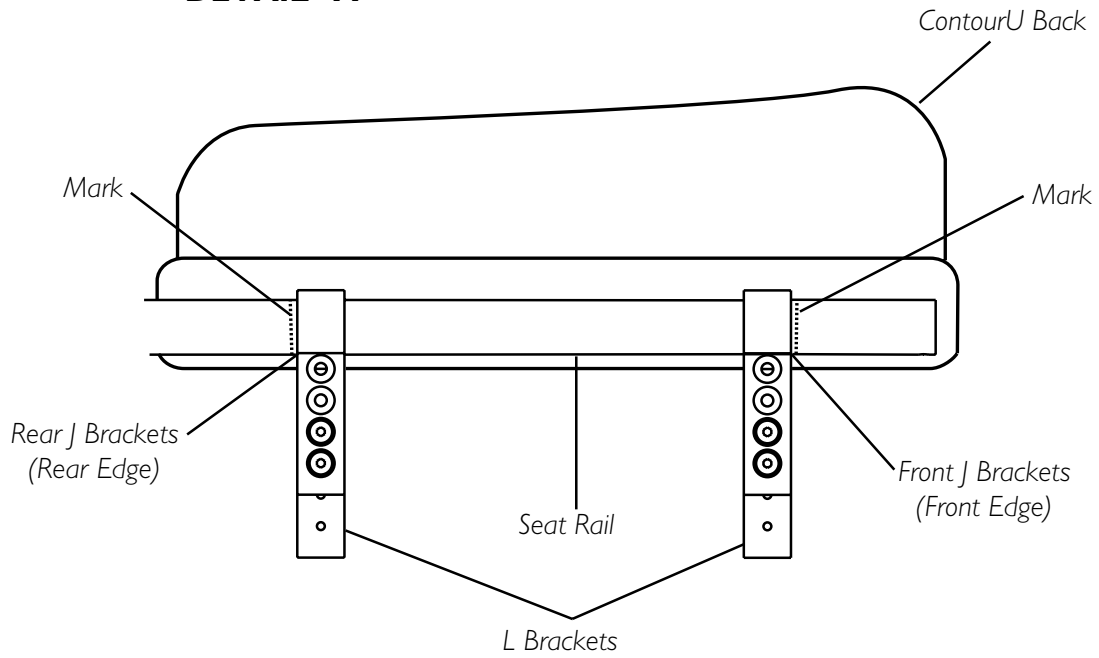

DETAIL "B"

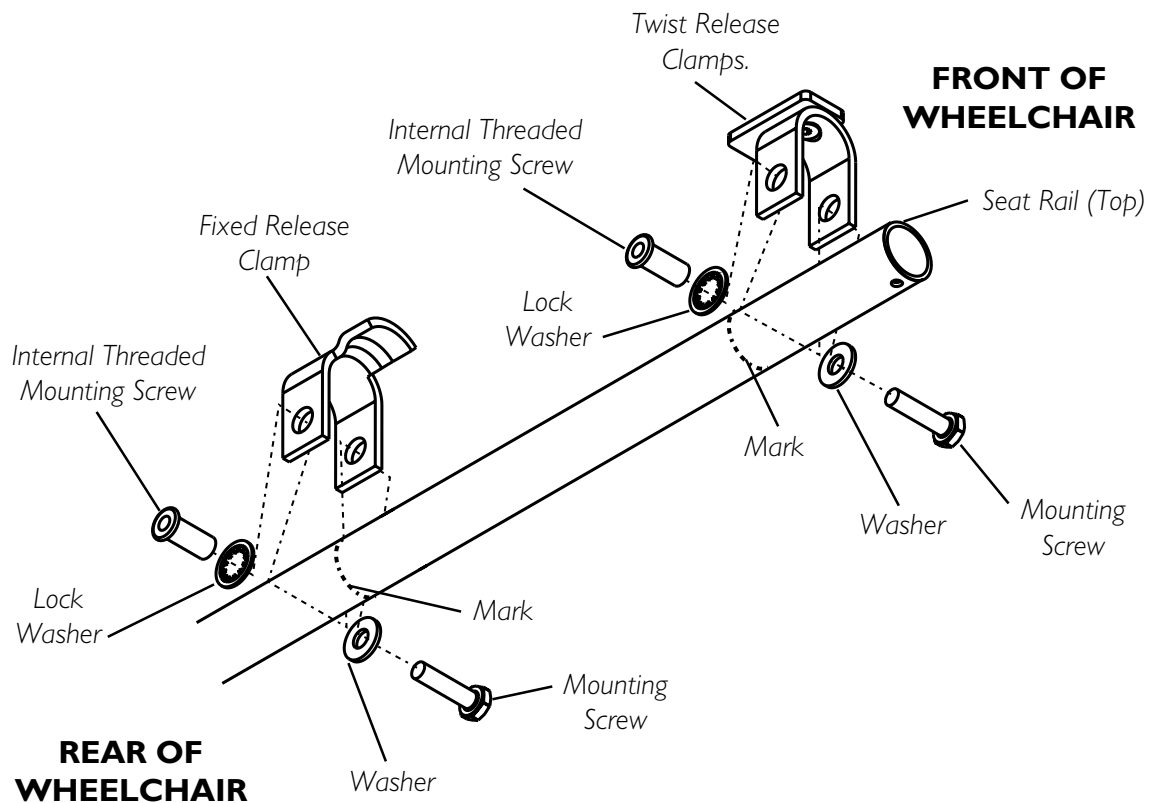

FIGURE 7 - INSTALLATION OF THE ON CHAIR MOUNTING KIT SEAT MOUNTING HARDWARE

INSTALLING THE SEAT L BRACKETS (FIGURE 8)

NOTE: When mounting the L brackets to the wood backed ContourU seat the L brackets may be reversed to allow for a wider range of seat height adjustments and shown in DETAIL "A" of FIGURE 8.

1. Position the ContourU seat between the seat rails and determine the mounting positions for the four (4) L brackets and seat depth.
2. If mounting L bracket to a pan seat, pull to remove the ContourU cushion from the seat pan.
3. Align L bracket with the edge of the ContourU seat and two (2) desired mounting holes as shown in FIGURE 8.
4. Perform one (1) of the following:
 - A. SEAT PAN: Using a backing plate and two (2) mounting screws, secure the L bracket to the seat pan back.
 - B. WOOD BACKED SEAT: Using two (2) mounting screws secure the L bracket to the wood backing of the seat cushion.
5. Repeat steps 3-4 for remaining three (3) L brackets.
6. If mounting L bracket to a seat pan, reinstall the ContourU cushion onto the seat pan.

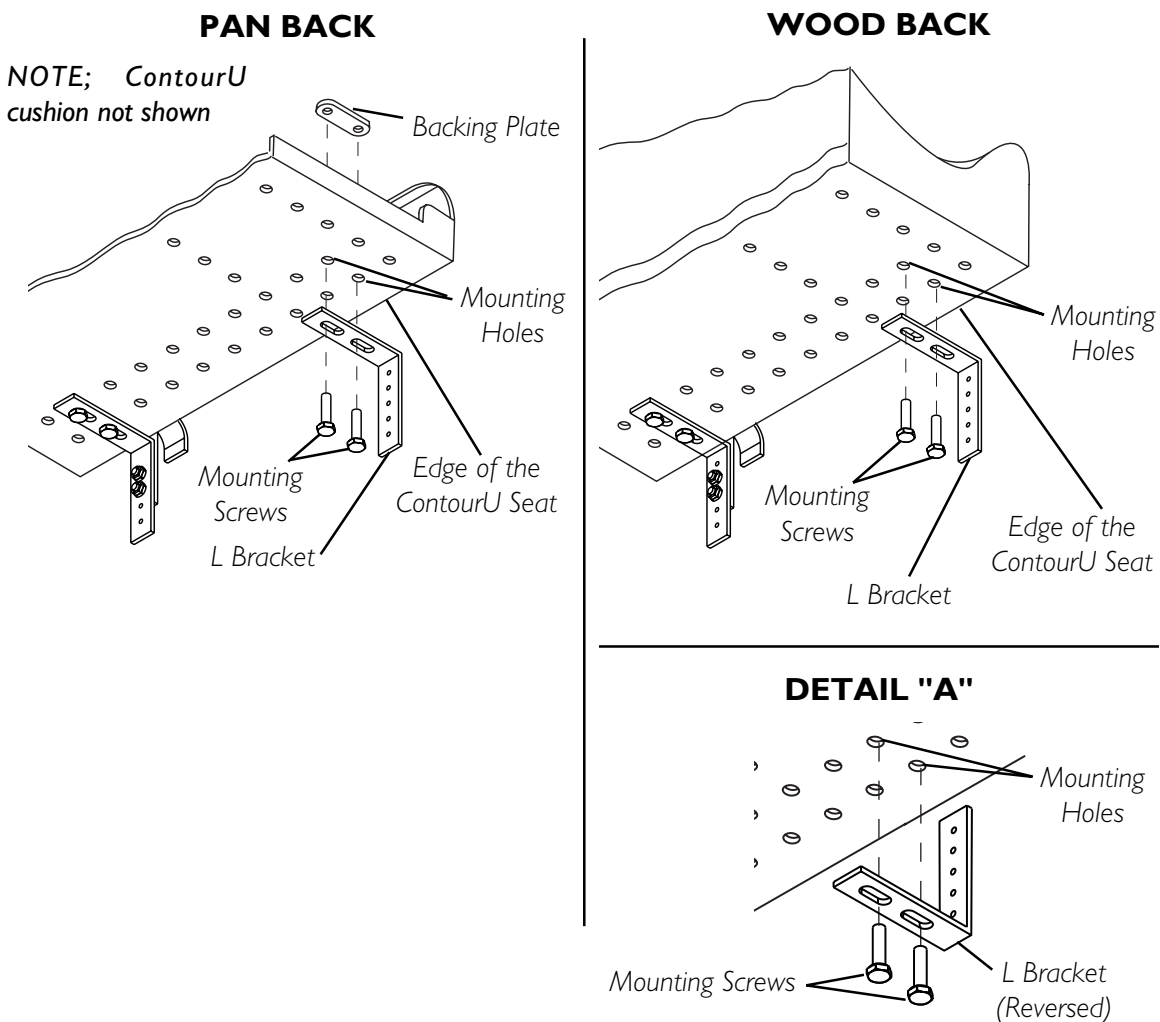

FIGURE 8 - INSTALLING THE SEAT L BRACKETS

INSTALLING THE SEAT J BRACKETS (FIGURE 9)

1. Position the ContourU seat between the seat rails to determine the approximate mounting position of the J brackets to ensure the appropriate height setting.
2. Align two (2) of four (4) mounting holes of the J bracket with two (2) of five (5) mounting holes on the L bracket as shown in FIGURE 9.
3. Using two (2) mounting screws and locknuts, secure the J bracket to the L bracket. Securely tighten mounting hardware.
4. Repeat STEPS 2-3 with three (3) remaining J brackets.
5. Install the ContourU seat. Refer to INSTALLING/REMOVING THE CONTOUR U SEATING SYSTEM SEAT in this instruction sheet.
6. Position the user into the wheelchair to determine if seat height adjustments are needed to properly fit the ContourU seat to the user. Refer to the wheelchair owner's manual.

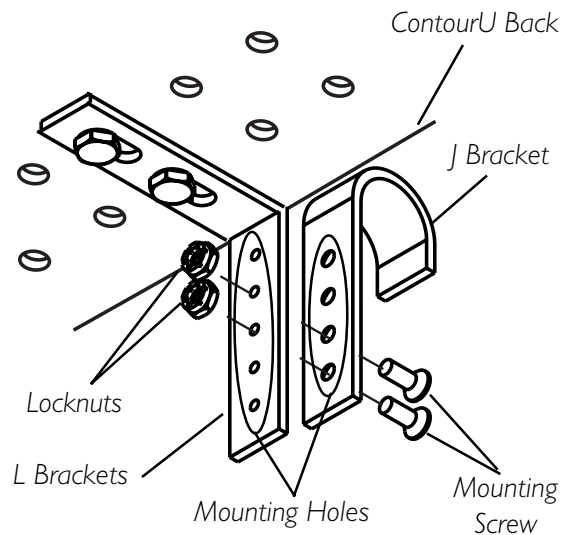

FIGURE 9 - INSTALLING THE SEAT J BRACKETS

INSTALLING/REMOVING THE CONTOUR U SEATING SYSTEM SEAT (FIGURE 10)

Installing

1. Ensure that the twist release clamps are in the OPEN position as shown in DETAIL "A" of FIGURE 10.
2. Position the rear J brackets securely into the fixed release clamps as shown in FIGURE 10.
3. Position the front J brackets onto the seat rail just below the twist release clamp.
4. Rotate the twist release clamps to the CLOSED position as shown in DETAIL "B" of FIGURE 10.

Removing

1. Rotate the two (2) twist release clamps to the OPEN position as shown in DETAIL "B" of FIGURE 10.
2. tilt the front of the ContourU seat up away from the seat rails.
3. Pulling UP, remove the ContourU seat from the seat rails.

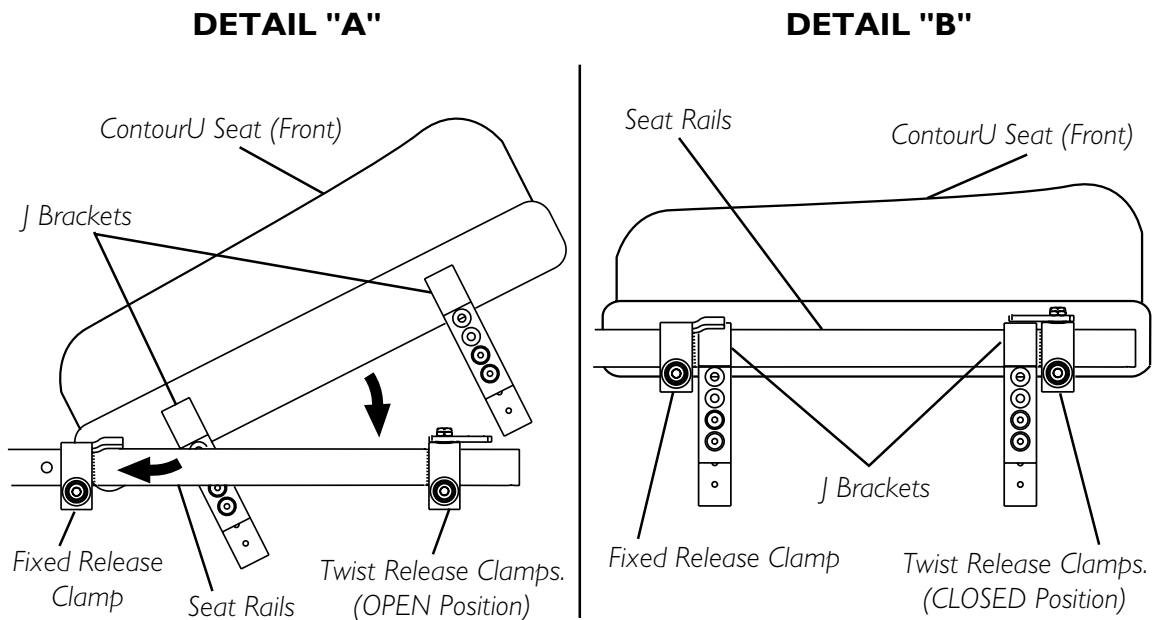

FIGURE 10 - INSTALLING/REMOVING THE CONTOUR U SEATING SYSTEM SEAT

ADJUSTING THE ON CHAIR MOUNTING KIT MOUNTING HARDWARE FOR THE CONTOUR U SEATING SYSTEM SEAT

NOTE: Refer to GENERAL and INSTALLATION WARNINGS in the SAFETY SUMMARY in this instruction sheet.

ADJUSTING THE CONTOUR U SEAT HEIGHT (FIGURE 11)

NOTE: There are six (6) height adjustments available on the ContourU seat with a seat pan.

NOTE: There are twelve (12) height adjustments available on the ContourU seat with a wood back. Six (6) mounting positions with the L brackets facing the front of the wheelchair and six (6) mounting positions with the L brackets facing the rear of the wheelchair.

NOTE: All four (4) J brackets must be adjusted to the same height unless seat angle adjustments are necessary. Refer to ADJUSTING THE CONTOUR U SEATING SYSTEM SEAT ANGLE in this instruction sheet after performing this procedure.

1. If necessary, remove the ContourU seat. Refer to REMOVING/INSTALLING THE CONTOUR U SEATING SYSTEM SEAT in this instruction sheet.
2. Remove the two (2) mounting screws and locknuts that secure the J bracket to the L bracket.
3. Align two (2) mounting holes of the J bracket with two (2) mounting holes of the L bracket to acquire the desired height as shown in DETAIL "A" of FIGURE 11.
4. Reinstall the two (2) mounting screws and locknuts that secure the J bracket to the L bracket. Securely tighten.
5. Repeat STEPS 3-4 to adjust the remaining three (3) J and L brackets.
6. Reinstall the ContourU seat onto the wheelchair. Refer to REMOVING/INSTALLING THE CONTOUR U SEATING SYSTEM SEAT in this instruction sheet.
7. Ensure the ContourU seat is set to the desired height. If necessary repeat STEPS 1-7 until desired height is achieved.

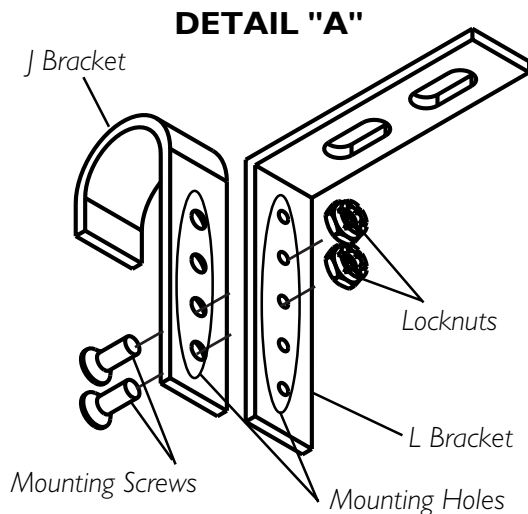

DEPTH ADJUSTMENTS

Pan or Wood Back	Additional Positions For Wood Back Only

FIGURE 11 - ADJUSTING THE CONTOUR U SEATING SYSTEM SEAT HEIGHT

ADJUSTING THE CONTOUR U SEATING SYSTEM SEAT ANGLE (FIGURE 12)

NOTE: Before performing this procedure all four (4) J brackets must be adjusted to the same height. Refer to ADJUSTING THE CONTOUR U SEAT HEIGHT in this instruction sheet.

NOTE: The seat angle is adjusted by repositioning the front and/or the rear J brackets.

NOTE: Adjustments made to J bracket(s) on one side of the ContourU seat MUST be also be made to the remaining J bracket(s) on the opposite side of the ContourU seat.

1. If necessary, install the ContourU seat. Refer to REMOVING/INSTALLING THE CONTOUR U SEATING SYSTEM SEAT in this instruction sheet.
2. With the ContourU seat installed on the wheelchair, determine which J bracket mounting positions are necessary to achieve the desired seat angle adjustment.
3. Remove the ContourU seat. Refer to REMOVING/INSTALLING THE CONTOUR U SEATING SYSTEM SEAT in this instruction sheet.
4. Remove the two (2) mounting screws and locknuts that secure the J bracket to the L bracket as shown in DETAIL "A" of FIGURE 12.
5. Align two (2) mounting holes of the J bracket with two (2) mounting holes of the L bracket to acquire the desired depth.
6. Reinstall the two (2) mounting screws and locknuts that secure the J bracket to the L bracket. Securely tighten.
7. Repeat STEPS 4-6 to adjust the remaining J and L brackets as necessary to achieve the desired seat angle.
8. Reinstall the ContourU back onto the wheelchair. Refer to REMOVING/INSTALLING THE CONTOUR U SEATING SYSTEM SEAT in this instruction sheet.
9. Ensure the ContourU seat is set to the desired angle and does not interfere with wheelchair operation or accessories. If necessary repeat STEPS 1-7 until desired depth is achieved.

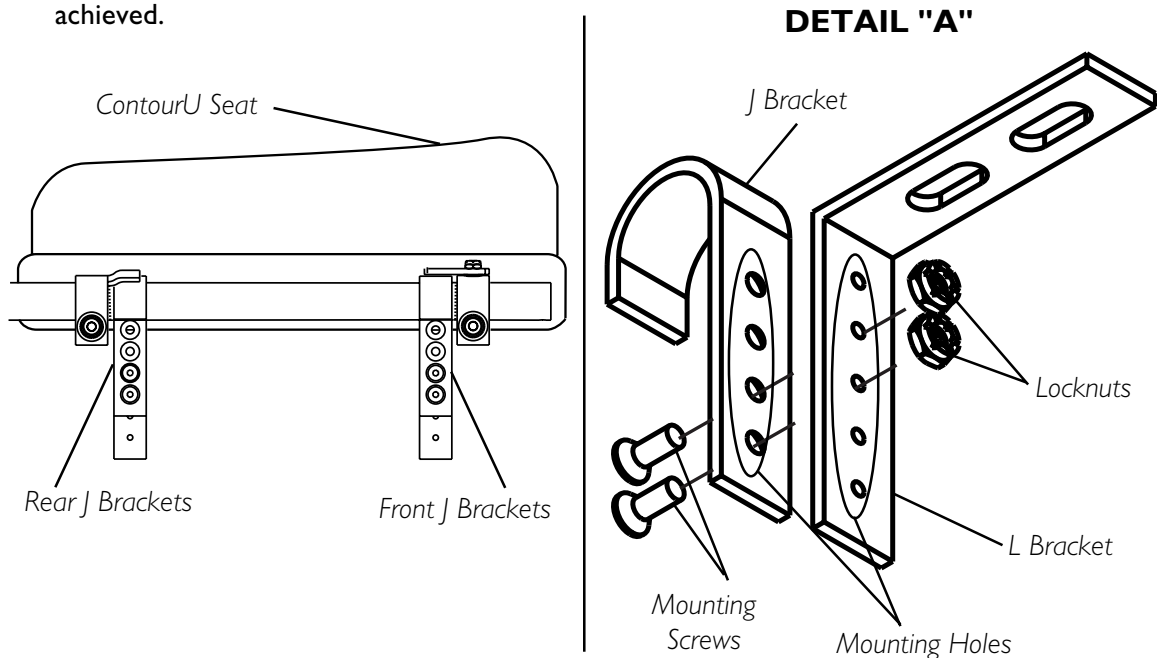

FIGURE 12 - ADJUSTING THE CONTOUR U SEATING SYSTEM SEAT ANGLE



Yes, you can.™

Invacare Corporation www.invacare.com

USA
One Invacare Way
Elyria, Ohio USA
44036-2125
800-333-6900

Canada
570 Matheson Blvd E Unit 8
Mississauga Ontario
L4Z4G4 Canada
800-668-5324

Invacare is a registered trademark of
Invacare Corporation.
Yes, you can. is a trademark of Invacare
Corporation.
© 2002 Invacare Corporation
Part No. 1106654 Rev A (I) 4/01