

Use & Care

G U I D E

Resource Saver automatic washer

A Note to You	2
Washer Safety	3
Parts and Features	4
Operating Your Washer	5
Using your washer.....	5
The high efficiency spray rinse system	7
Loading	7
Selecting a fabric speed and cycle time	7
ACCUWASH™ temperature control system	9
MAGIC CLEAN® lint filter	10
Understanding normal washer sounds	10
Understanding what happens in each cycle.....	11
Caring for Your Washer	12
Troubleshooting	13
Requesting Assistance or Service	17
Warranty	20

In the U.S.A. for assistance or service,
call the Consumer Assistance Center:

1-800-253-1301

In Canada for assistance or service,
see page 18.



www.whirlpool.com

A NOTE TO YOU

Thank you for buying a WHIRLPOOL® appliance.

The Whirlpool Brand is committed to designing quality products that consistently perform for you to make your life easier. To ensure that you enjoy years of trouble-free operation, we developed this Use and Care Guide. It is full of valuable information about how to operate and maintain your appliance properly and safely. Please read it carefully.

Also, complete and mail the **Ownership Registration Card** provided with your appliance. The card helps us notify you about any new information on your appliance.

Please record your model's information.

Whenever you call to request service for your appliance, you need to know your complete model number and serial number. You can find this information on the model and serial number label (see the diagram on the "Parts and Features" page for the location of the label). Also, record the other information shown in the next column.

Model Number _____

Serial Number _____

Purchase Date _____

Dealer Name _____

Dealer Address _____

Dealer Phone _____

Keep this book and the sales slip together in a safe place for future reference.

Our Consumer Assistance Center number is toll free.

1-800-253-1301

To find detailed product information, the location of the nearest Whirlpool dealer or authorized servicer, to purchase an accessory item, or register your appliance on-line, please visit our Web site at www.whirlpool.com

In Canada, for assistance or service, see the "Requesting Assistance or Service" section.

In Canada, visit our Web site at www.whirlpool.com/canada

WASHER SAFETY

Your safety and the safety of others is very important.

We have provided many important safety messages in this manual and on your appliance. Always read and obey all safety messages.



This is the safety alert symbol.

This symbol alerts you to hazards that can kill or hurt you and others.

All safety messages will be preceded by the safety alert symbol and the word "DANGER" or "WARNING." These words mean:

⚠ DANGER

You will be killed or seriously injured if you don't follow instructions.

⚠ WARNING

You can be killed or seriously injured if you don't follow instructions.

All safety messages will identify the hazard, tell you how to reduce the chance of injury, and tell you what can happen if the instructions are not followed.

IMPORTANT SAFETY INSTRUCTIONS

WARNING – To reduce the risk of fire, electric shock, or injury to persons when using the washer, follow basic precautions, including the following:

- Read all instructions before using the washer.
- Do not wash articles that have been previously cleaned in, washed in, soaked in, or spotted with gasoline, dry-cleaning solvents, other flammable, or explosive substances as they give off vapors that could ignite or explode.
- Do not add gasoline, dry-cleaning solvents, or other flammable, or explosive substances to the wash water. These substances give off vapors that could ignite or explode.
- Under certain conditions, hydrogen gas may be produced in a hot water system that has not been used for 2 weeks or more. **HYDROGEN GAS IS EXPLOSIVE.** If the hot water system has not been used for such a period, before using the washing machine, turn on all hot water faucets and let the water flow from each for several minutes. This will release any accumulated hydrogen gas. As the gas is flammable, do not smoke or use an open flame during this time.
- Do not allow children to play on or in the washer. Close supervision of children is necessary when the washer is used near children.
- Before the washer is removed from service or discarded, remove the door.
- Do not reach into the washer if the tub or agitator is moving.
- Do not install or store the washer where it will be exposed to the weather.
- Do not tamper with controls.
- Do not repair or replace any part of the washer or attempt any servicing unless specifically recommended in this Use and Care Guide or in published user-repair instructions that you understand and have the skills to carry out.
- See Installation Instructions for grounding requirements.

– SAVE THESE INSTRUCTIONS –

PARTS AND FEATURES

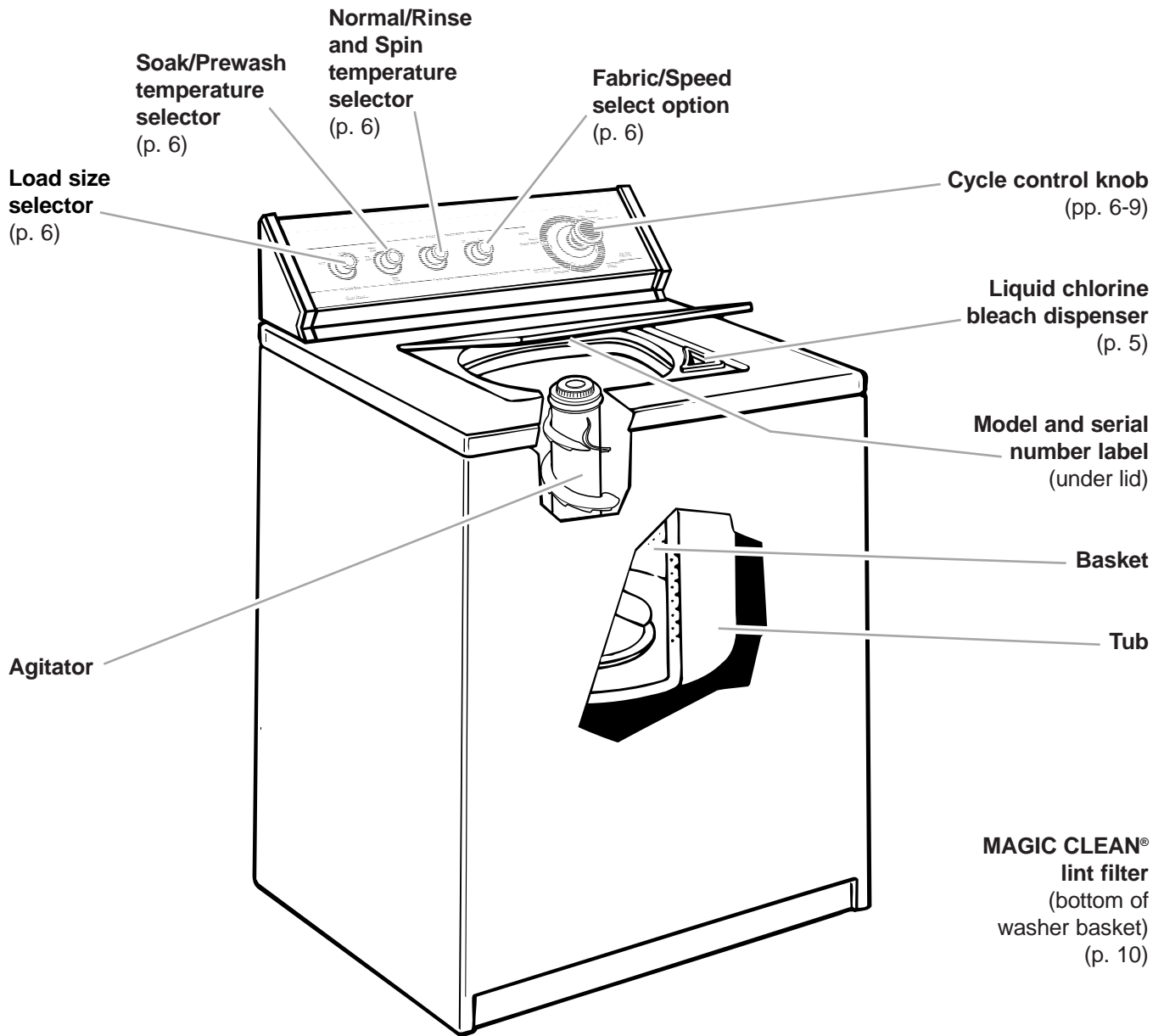

CONTROL PANEL

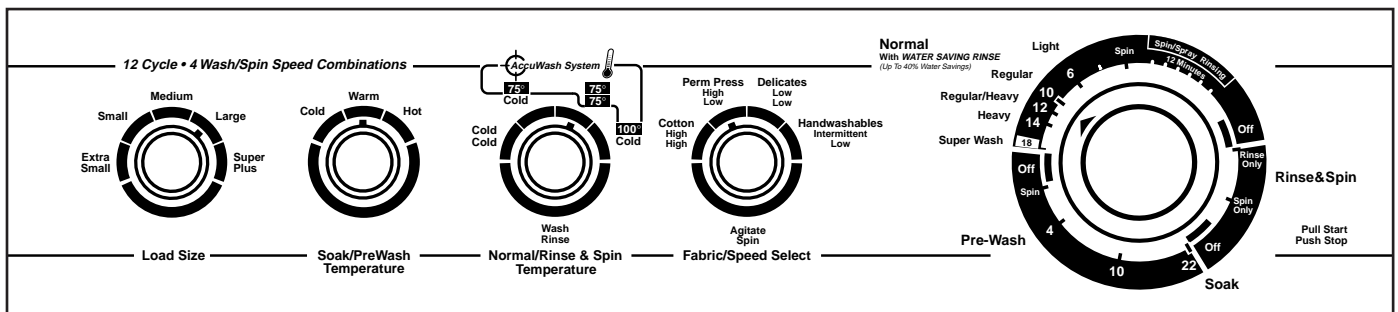

OPERATING YOUR WASHER

USING YOUR WASHER

⚠ WARNING



Fire Hazard

Never place items in the washer that are dampened with gasoline or other flammable fluids.

No washer can completely remove oil.

Do not dry anything that has ever had any type of oil on it (including cooking oils).

Doing so can result in death, explosion, or fire.

⚠ WARNING



Electrical Shock Hazard

Plug into a grounded 3 prong outlet.

Do not remove ground prong.

Do not use an adapter.

Do not use an extension cord.

Failure to follow these instructions can result in death, fire, or electrical shock.

1. Measure detergent and pour it into the washer.

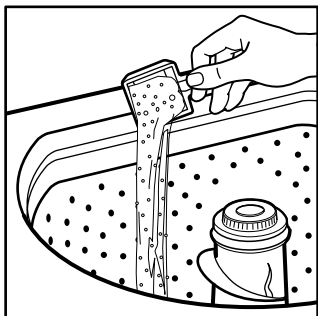

- If desired, you may also add powder or liquid color-safe bleach.
- Use less detergent when using a small load size.

2. Drop a sorted load of clothes loosely into your washer, filling to the top row of holes.

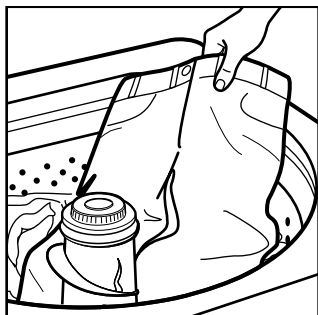

- Load evenly to maintain washer balance. Mix large and small items.
- Items should move easily through the wash water. Overloading can cause poor cleaning.
- To reduce wrinkling of

permanent press clothes and some synthetic knits, use a large load size to provide more space (see step 5).

3. (OPTIONAL STEP) Pour measured liquid chlorine bleach into the

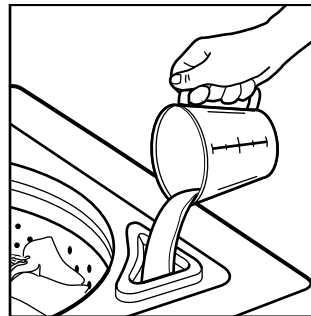

liquid chlorine bleach into the liquid chlorine bleach dispenser. Bleach will be diluted automatically during the wash part of the cycle.

- Never use more than 1 cup (250 mL) for a full load. Use less with a smaller load size.
- Follow the manufac-

turer's directions for safe use.

- To avoid spilling, use a cup with a pouring spout. Do not let bleach splash, drip, or run down into the washer basket.
- Make sure you use only liquid chlorine bleach in this dispenser.

continued on next page

USING YOUR WASHER (CONT.)

4. Close the washer lid.

5. Turn the **Load Size** selector to the correct setting for your wash load and the type of fabric being washed.

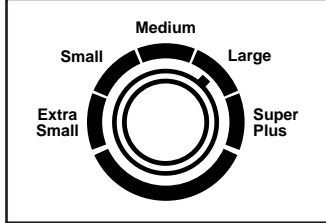

- Your washer has 5 load size settings.
- Choose a load size that allows the load to move freely for best fabric care. See “Loading” later in this section.

• Change the setting after the washer has started filling by turning the selector to a different setting.

6. If a Soak or Prewash cycle is desired, set the

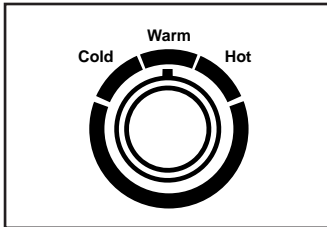

Soak/PreWash Temperature selector to the water temperature that matches the type of fabrics and soils in your load.

- Follow garment label instructions.
- Select Cold (colors that bleed, light soils), Warm (bright colors, moderate to light soils), or Hot (whites and pastels, heavy or greasy soils) water.

7. Select a Normal wash temperature or a Rinse and Spin temperature with the

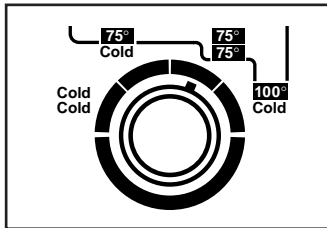

Normal/Rinse and Spin Temperature selector. Match the water temperature with the type of fabrics and soils in your load.

Your washer uses the ACCUWASH™ temperature control to regulate incoming hot and cold water in the Normal wash cycle and Rinse and Spin cycle (see the “ACCUWASH™ Temperature Control System” section).

8. Turn the **Fabric/Speed Select** to the setting that matches the type of fabric in your load. See the “Selecting a Fabric Speed and Cycle Time” section.

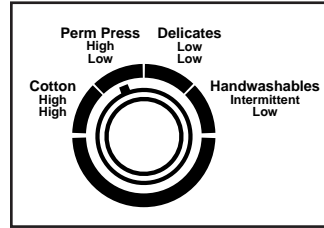

• The selector lets you customize your wash cycles for 4 types of fabrics: Cotton, Permanent Press, Delicates and Handwashables.

- The selections will provide different agitation and spin speeds.

9. Push in the Cycle Control knob and turn it to the wash cycle you want. See the “Selecting a Fabric Speed and Cycle Time” section.

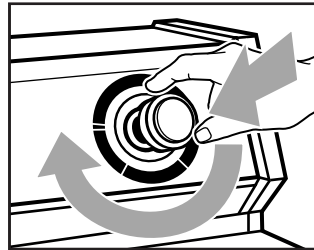

• Reduce the wash time when using a small load size setting.

10. Pull out the Cycle Control knob to start the washer.

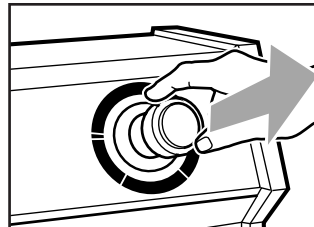

NOTE: To stop the washer at any time, push in the Cycle Control knob. To restart the washer, close the lid (if open) and pull out the Cycle Control knob.

THE HIGH EFFICIENCY SPRAY RINSE SYSTEM

The washing portion for this system ends with a drain and spin the same as do traditional wash cycles. After that, the spray rinse system begins.

- The washer continues to spin at the end of the wash cycle. There is no fill.
- Fresh water is added as the machine spins the load. Repeated spinning with spray rinses achieves excellent rinsing results and uses less water than does a traditional rinse cycle.

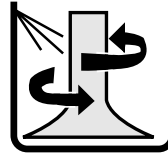

Spray rinsing and spinning

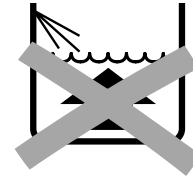

No fill

NOTES: To assure proper spray rinsing:

- Do not open the washer lid during spray rinsing.
- **Do not use liquid fabric softeners.** You could stain your clothes. Use a fabric softener sheet in the dryer instead.

LOADING

Loading suggestions

For these suggested full-sized loads, set the Load Size selector to the highest load size setting.

SUPER Capacity PLUS Washers			
Heavy Work Clothes 3 pair pants 3 shirts 4 pair jeans 1 coverall 1 overall	Delicates 3 camisoles 1 quilted robe 4 slips 4 panties 2 bras 2 nighties 1 baby's dress	Towels 10 bath towels 10 hand towels 14 wash cloths 1 bath mat	Mixed Load 3 double sheets 4 pillowcases 8 T-shirts 6 pair shorts 2 shirts 2 blouses 8 handkerchiefs

SELECTING A FABRIC SPEED AND CYCLE TIME

This section describes the available wash cycles and will help you make the best cycle selections for your wash loads. The Fabric/Speed Select is used with the Cycle Control knob to design a cycle to match the fabrics and soil levels in your load.

- The washer pauses briefly throughout each cycle. These pauses are normal. Refer to "Understanding normal washer sounds" to learn more about the sounds you may hear during a wash cycle.
- Refer to "Understanding what happens in each cycle" later in this section to learn what happens during a wash cycle.

SELECTING A FABRIC SPEED AND CYCLE TIME (CONT.)

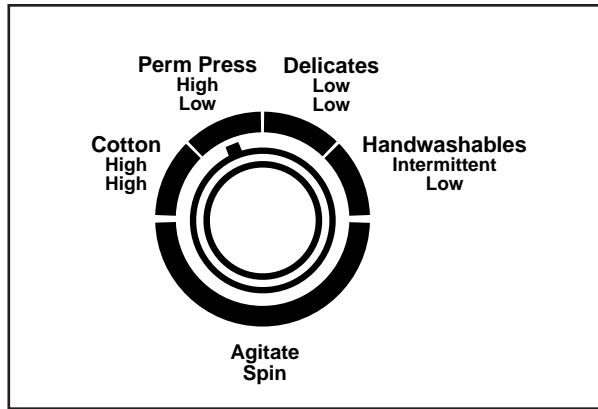

Fabric/Speed Select

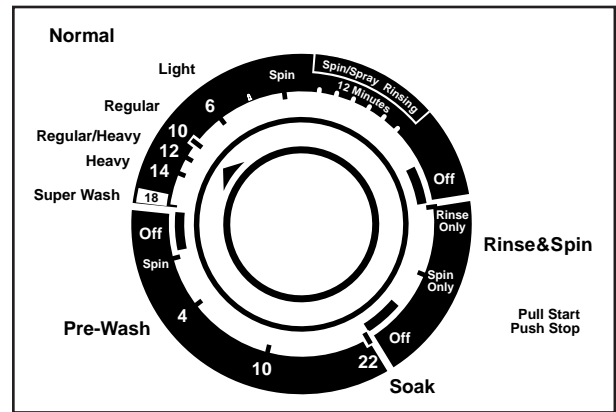

Cycle Control knob

Normal cycle

The Normal cycle is used with the Fabric/Speed Select to provide the best wash and spin action for your load. Select 6, 10, 12 or 14 minutes of wash time depending on the soil levels in your load. (See chart below.)

Super Wash - Select the 18-minute Super Wash feature to wash heavily soiled loads that need maximum soil removal.

LOAD TYPE	FABRIC/SPEED SELECT SETTING	Agitation	Spin	CYCLE CONTROL KNOB SETTING	COMMENTS
Sturdy fabrics Maximum soil	Cotton	High	High	Super Wash 18 minutes	<ul style="list-style-type: none"> Maximum soil removal
Sturdy fabrics	Perm Press or Cotton	High High	Low High	Heavy 14 minutes	<ul style="list-style-type: none"> Removes heavy soils
Cottons	Perm Press or Cotton	High High	Low High	Regular/Heavy 12 minutes	<ul style="list-style-type: none"> Removes moderate to heavy soils
Permanent press Synthetic fabrics	Perm Press or Cotton	High High	Low High	Regular 10 minutes	<ul style="list-style-type: none"> Removes moderate soils
Delicates Washable knits Linens	Delicates	Low	Low	Light 6 minutes	<ul style="list-style-type: none"> Provides gentle cleaning for light soils Better removal of water for faster drying times
Hand-washables	Handwashables	Intermittent	Low	Light 6 Minutes	<ul style="list-style-type: none"> Provides gentle cleaning for special-care items

SELECTING A FABRIC SPEED AND CYCLE TIME (CONT.)

Rinse and Spin cycle

When washing heavily soiled clothes, or washing special-care items, you may find an extra rinse and spin is needed. An extra spin only may help shorten drying times for some heavy fabrics or special-care items by removing excess water.

- For a rinse and spin, turn the Cycle Control knob to Rinse Only.
- For a spin only, turn the Cycle Control knob to Spin Only.

NOTE: Rinse water temperature and spin speed will be the same as your previous wash cycle unless new selections are made.

Soak Cycle

The Soak cycle features brief periods of agitation and soak time to help remove heavy soils and stains that need pretreatment. Select 10 or 22 minutes of soak time, depending on the soil level of your load.

For high speed agitation, set the Fabric/Speed Select to Cotton or Perm Press.

For low speed agitation, set the Fabric/Speed Select to Delicates.

For intermittent agitation, set the Fabric/Speed Select to Handwashables.

- Select a Soak/Prewash Temperature to match the type of fabric and soils in your load.
- Use the amount of detergent or presoak additive recommended by manufacturer.

- The Soak cycle automatically advances into the Pre-Wash cycle.
- After the cycle ends, set a new wash cycle.

Pre-Wash Cycle

The Pre-Wash cycle features 4 minutes of agitation to help remove heavy soils and stains that need pretreatment. This cycle provides additional washing prior to the desired cycle. Because the Pre-Wash cycle does not rinse, a new wash cycle should be selected after the Pre-Wash cycle ends.

For high speed agitation, set the Fabric/Speed Select to Cotton or Perm Press.

For low speed agitation, set the Fabric/Speed Select to Delicates.

For intermittent agitation, set the Fabric/Speed Select to Handwashables.

- Select a Soak/Prewash Temperature to match the type of fabric and soils in your load.
- Use Pre-Wash for heavily soiled loads that need more than one wash.
- After the cycle ends, set a new wash cycle.

ACCUWASH™ TEMPERATURE CONTROL SYSTEM

Your washer uses the ACCUWASH automatic temperature control in the Normal wash cycle and Rinse and Spin cycle. ACCUWASH maintains a uniform water temperature by regulating incoming hot and cold water. This helps eliminate undissolved detergent and ensures consistent cleaning results.

- Select a wash water temperature of 75°F (24°C) for items that bleed, handwashables, or lightly soiled items.
- Select a wash water temperature of 100°F (38°C) for cleaning whites and bright colors or moderately to heavily soiled items.

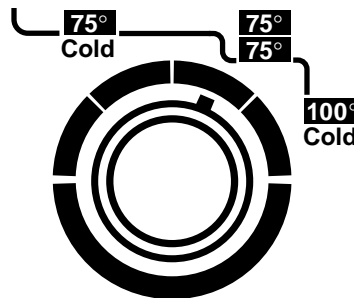

MAGIC CLEAN[®] LINT FILTER

Your washer has a self-cleaning lint filter at the bottom of the basket. Wash and rinse water flow over the filter during agitation, separating the lint from the water. The lint spins out of the system during the spin part of the cycle.

If your washer drains into a tub, remove any lint collected in the tub or strainer.

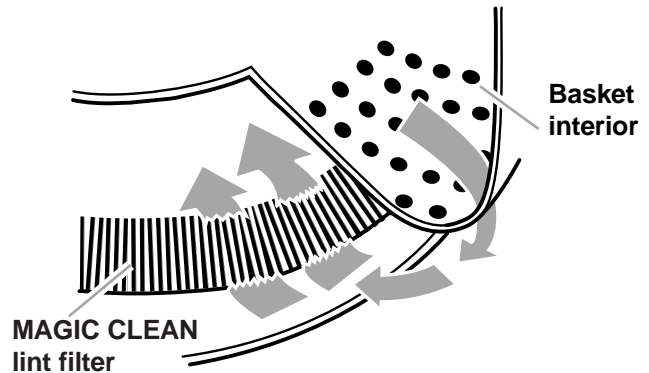

UNDERSTANDING NORMAL WASHER SOUNDS

Your new washer may make sounds your old one didn't. Because the sounds may be unfamiliar, you may be concerned about them. Don't be; most of them are normal.

The following describes some of the sounds you may hear and what causes them.

During washing

When you select a small load size setting, your washer has a lower water level. This may cause a clicking sound from the upper part of the agitator.

During drain

If water is drained quickly from your washer (depending on your installation), you may hear air being pulled through the pump during the end of draining.

After drain and before spin

When the cycle changes from draining to spinning, you may hear gears engaging.

UNDERSTANDING WHAT HAPPENS IN EACH CYCLE

When the Cycle Control knob is set to a number and pulled out, the washer fills (to the selected load size) before agitation and timing start. The washer begins agitating immediately after filling; agitation occurs with the washer lid up or down.

During agitation, the XTRA ROLL ACTION™ agitator

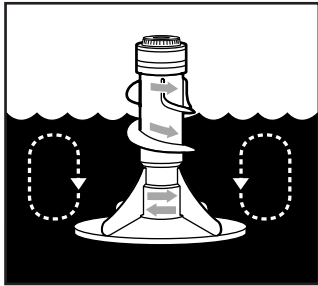

creates a continuous rollover action that provides a thorough cleaning of the wash load.

After agitation starts, the Cycle Control knob turns clockwise until it points to an Off area and the cycle ends.

NOTE: The washer pauses briefly throughout each cycle. These pauses are normal for washer operation.

Sequence of cycles

WASH	
	Fill
	Wash selected time
	Drain No agitation
	Spin

RINSE	
	Continues to spin-No fill
	Spray rinses-Spin
	Spin
	Off

CARING FOR YOUR WASHER

CLEANING YOUR WASHER

Cleaning the exterior

Use a soft, damp cloth or sponge to wipe up any spills such as detergent or bleach. Occasionally wipe the outside of your washer to keep it looking new.



Cleaning the interior

Clean your washer interior by mixing 1 cup (250 mL) of chlorine bleach and 2 cups (500 mL) of detergent. Pour this into your washer and run it through a complete cycle using hot water. Repeat this process if necessary.

NOTE: Remove any hard water deposits using only cleaners labeled as washer safe.

WINTER STORAGE, MOVING, VACATION CARE

Install and store your washer where it will not freeze. Because some water may stay in the hoses, freezing can damage your washer. If storing or moving your washer during freezing weather, winterize it.

To winterize washer:

1. Shut off both water faucets.
2. Disconnect and drain water inlet hoses.
3. Put 1 quart (1 L) of R.V.-type antifreeze in the basket.
4. Run washer on Rinse Only for about 30 seconds to mix the antifreeze and water.
5. Unplug washer or disconnect power.

To use washer again:

1. Flush water pipes and hoses.
2. Reconnect water inlet hoses.
3. Turn on both water faucets.
4. Plug in washer or reconnect power.
5. Run the washer through a complete cycle with 1 cup (250 mL) of detergent to clean out antifreeze.

Non-use or vacation care:

Operate your washer only when you are at home. If you will be on vacation or not using your washer for an extended period of time, you should:

- Unplug the power supply cord or turn off electrical power to the washer.
- Turn off the water supply to the washer. This helps avoid accidental flooding (due to a water pressure surge) while you are away.

INLET HOSES

Replace inlet hoses after 5 years of use to reduce the risk of hose failure. Inspect and replace inlet hoses if bulges, kinks, cuts, wear, or leaks are found.

When replacing your inlet hoses, mark the date of replacement on the label with a permanent marker.

TROUBLESHOOTING

COMMON WASHING PROBLEMS

Problem...	Cause...	Solution ...
Washer leaks NOTE: After checking these, check household plumbing.	<ul style="list-style-type: none"> ● Fill hoses not tight. ● Fill hose washers not properly seated. ● Drain hose clamp not properly installed or is off. ● Drain is clogged. ● Tub moved forward during unloading, causing water to deflect off tub ring. ● Unit not level, causing water to deflect off tub ring. ● Fill or spray rinses are deflecting off load. Washer is overloaded or load is unbalanced. 	<ul style="list-style-type: none"> ● Tighten hoses. See Installation Instructions. ● Reseat (reposition) washers. See Installation Instructions. ● Clamp drain hose. ● Unclog drain. Sink and standpipe must be able to handle 17 gallons (64 L) of water per minute. ● Ensure tub is centered before starting washer. ● Ensure front feet are installed and nuts are tightened. Level washer. ● Redistribute the load, or reduce load size.
Washer won't drain/spin	<ul style="list-style-type: none"> ● Drain hose is clogged. ● Lid is open. ● End of drain hose more than 72 inches (183 cm) above floor. ● Too much detergent – excessive sudsing. ● Low voltage or using an extension cord. 	<ul style="list-style-type: none"> ● Unclog hose. See Installation Instructions for proper installation of drain hose. ● Close the lid. ● Lower drain hose. ● Use less detergent. ● Check electrical source or call electrician. Do not use extension cords.
Wet loads	<ul style="list-style-type: none"> ● Wrong spin speed for load being washed. ● Cold rinses. 	<ul style="list-style-type: none"> ● Choose a high spin speed. ● Cold rinses leave loads wetter than warm rinses. This is normal.
Washer continues to fill/drain or cycle stuck NOTE: Washer pauses briefly throughout each cycle. This is normal.	<ul style="list-style-type: none"> ● Top of drain hose is lower than water level in washer. ● Drain hose fits too tightly into standpipe. ● Drain hose taped into standpipe. 	<ul style="list-style-type: none"> ● Raise the drain hose. It must be higher for proper operation. ● Adjust drain hose for loose yet secure fit. See Installation Instructions. ● Do not seal off drain hose with tape. The hose needs an air gap.
Washer makes noise	<ul style="list-style-type: none"> ● Load is unbalanced. ● Washer is not level. ● Nuts on front feet not tight. ● Yellow shipping strap with cotter pins not completely removed. 	<ul style="list-style-type: none"> ● Redistribute load. ● Level washer. Reset rear leveling legs. See Installation Instructions. ● Tighten nuts. ● See Installation Instructions.

continued on next page

COMMON WASHING PROBLEMS (CONT.)

Problem...	Cause...	Solution...
Washer makes noise (cont.)	<ul style="list-style-type: none"> ● Gears engaging after drain and before spin. ● Upper part of agitator clicks during wash. 	<ul style="list-style-type: none"> ● This is normal. ● This is normal.
Won't fill/rinse/agitate or wrong temperature	<ul style="list-style-type: none"> ● Power cord not plugged in. ● Timer (Cycle Control knob) dial is not lined up. ● Water inlet valve screens are plugged. ● Water is turned off. ● Hot and cold hoses are reversed. ● Inlet hose is kinked. 	<ul style="list-style-type: none"> ● Plug in power cord. ● Turn timer knob to the right slightly and pull to start. ● Clean screens. ● Turn on water. ● Reverse hoses. ● Straighten hoses.
Washer stops	<ul style="list-style-type: none"> ● Power cord not plugged in. ● No power at plug. ● Fuse blown or circuit breaker open. ● Using an extension cord. ● Timer dial is not lined up. ● Timer knob not pulled out. ● Machine is overloaded. 	<ul style="list-style-type: none"> ● Plug in power cord. ● Check electrical source or call electrician. ● Replace fuse or reset circuit breaker. If problem continues, call electrician. ● Do not use extension cords. ● Turn timer to the right slightly and pull to start. ● Set and pull out knob. ● Wash smaller loads.
Agitator operation	<ul style="list-style-type: none"> ● The top of the agitator moves only in one direction. ● The top of the agitator is loose. 	<ul style="list-style-type: none"> ● This is normal. ● This is normal.
Water level seems too low or washer not completely filling	<ul style="list-style-type: none"> ● The top of the agitator is much higher than the highest water level. This creates a perception of the washer not being full. 	<ul style="list-style-type: none"> ● This is normal.
Washer tub is crooked	<ul style="list-style-type: none"> ● Tub is pulled forward when unloading. ● Tub moves. ● Unit not level. 	<ul style="list-style-type: none"> ● Push tub to center before starting. ● This is normal. ● Ensure front feet are installed and nuts tightened. Level washer. Reset rear leveling legs. See Installation Instructions.

COMMON WASHING PROBLEMS (CONT.)

Problem...	Cause...	Solution...
Residue or lint on load	<ul style="list-style-type: none"> ● Improper sorting. ● Overloading. ● Paper or tissue in pockets. ● Not enough detergent. ● Detergent not dissolving. ● Wash water colder than 70°F (21°C). 	<ul style="list-style-type: none"> ● Sort lint givers (towels, chenille) from lint takers (corduroy, synthetics). Also sort by color. ● Lint can be trapped in load if overloaded. Wash smaller loads. ● Clean out pockets before washing. ● Use enough detergent to hold lint in water. ● Use wash water warmer than 70°F (21°C). ● Use wash water warmer than 70°F (21°C).
Tearing	<ul style="list-style-type: none"> ● Overloading. Improper use of washer. ● Improper use of chlorine bleach. ● Sharp items not removed from pockets; fasteners not fastened. ● Items damaged before washing. 	<ul style="list-style-type: none"> ● Loads should move freely during wash. Wash smaller loads. ● Do not pour chlorine bleach directly on load. Wipe up bleach spills. Undiluted bleach will damage fabrics. ● Clean out pockets before washing. Zip zippers before washing. ● Mend rips and broken threads in seams before washing.
Stains on load	<ul style="list-style-type: none"> ● Improper use of fabric softener. ● Iron (rust) in water. ● Not enough detergent used, causing soil to be redeposited. ● Dye transfer due to not sorting loads properly. ● Dye transfer due to not unloading washer promptly. ● Not removing load promptly. 	<ul style="list-style-type: none"> ● Do not use liquid fabric softener. Use a fabric softener sheet in the dryer instead. ● Install an iron filter. ● Use enough detergent to remove soil and hold it in suspension. ● Sort dark clothing from whites and lights. ● Unload the washer as soon as it stops. ● Unload the washer as soon as it stops.
Load is wrinkled	<ul style="list-style-type: none"> ● Wrong spin speed for fabrics being washed. ● Overloading. ● Wash water not warm enough to relax wrinkles. ● Hoses reversed. 	<ul style="list-style-type: none"> ● Use a setting with a low spin speed. ● Loads should move freely during wash. Wash smaller loads. ● If safe for fabric, use 100°F (38°C) wash water. Use cold rinse water. ● Reverse hoses.

continued on next page

COMMON WASHING PROBLEMS (CONT.)

Problem...	Cause...	Solution...
Load is tangled/twisted	<ul style="list-style-type: none"> ● Overloading. ● Clothes wrapped around agitator. 	<ul style="list-style-type: none"> ● Loads should move freely during wash. Wash smaller loads. ● Do not wrap items around agitator.
Clogged dispensers or bleach leaking	<ul style="list-style-type: none"> ● Use of color-safe bleach in chlorine bleach dispenser. ● Improper use of chlorine bleach. 	<ul style="list-style-type: none"> ● Add powder or liquid color-safe bleach directly to the basket. Do not use chlorine bleach dispenser for color-safe bleach. ● Always measure bleach before adding to the dispenser. Carefully pour into the dispenser. Wipe up bleach spills.
Gray whites, dingy colors	<ul style="list-style-type: none"> ● Dye transfer. ● Wash temperature too low. ● Not enough detergent. ● Hard water. 	<ul style="list-style-type: none"> ● Sort dark clothes from whites and lights. ● If safe for fabric, use 100°F (38°C) wash water. ● Use more detergent for washing heavy soils in cold or hard water. ● Use more detergent when washing in hard water.

REQUESTING ASSISTANCE OR SERVICE

IF YOU NEED ASSISTANCE OR SERVICE IN THE U.S.A.

Call the Whirlpool Consumer Assistance Center toll free at 1-800-253-1301. Our consultants are available to assist you.



When calling:

Please know the purchase date, and the complete model and serial number of your appliance (see "A Note to You"). This information will help us better respond to your request.

Our consultants provide assistance with:

- Features and specifications on our full line of appliances
- Installation information
- Use and maintenance procedures

- Accessory and repair parts sales
- Specialized customer assistance (Spanish speaking, hearing impaired, limited vision, etc.)
- Referrals to local dealers, service companies, and repair parts distributors.

Whirlpool service technicians are trained to fulfill the product warranty and provide after-warranty service, anywhere in the United States.

To locate the authorized Whirlpool service company in your area, you can also look in your telephone directory Yellow Pages.

IF YOU NEED REPLACEMENT PARTS

If you need to order replacement parts, we recommend that you only use FSP® factory authorized parts. FSP replacement parts will fit right and work right, because they are made to the same exacting specifications used to build every new WHIRLPOOL® appliance.

To locate FSP replacement parts in your area, call our Consumer Assistance Center telephone number or your nearest authorized service center.

FOR FURTHER ASSISTANCE

If you need further assistance, you can write to Whirlpool with any questions or concerns at:

Whirlpool Brand Home Appliances
Consumer Assistance Center
c/o Correspondence Dept.
2000 North M-63
Benton Harbor, MI 49022-2692

Please include a daytime phone number in your correspondence.

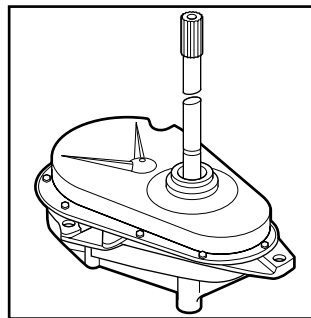

Gearcase assembly covered by your warranty.

IF YOU NEED ASSISTANCE OR SERVICE IN CANADA

1. If the problem is not due to one of the items listed in "Troubleshooting"*

Contact the dealer from whom you purchased your appliance, or call the Inglis Limited Consumer Assistance Centre toll free, **8:30 a.m. – 6 p.m. (EST)**, at **1-800-461-5681**.



2. If you need service* ...

Contact your nearest Inglis Limited Appliance Service branch or authorized servicing outlet to service your appliance. (See list below.)

* When asking for assistance or service, please provide a detailed description of the problem, your appliance's complete model and serial numbers, and the purchase date. (See the "A Note to You" section.) This information will help us respond properly to your request.

Inglis Limited Appliance Service – Consumer Services

Direct service branches:

BRITISH COLUMBIA		1-800-665-6788
ALBERTA		1-800-661-6291
ONTARIO (except 807 area code)	Ottawa area Outside the Ottawa area	1-800-267-3456 1-800-807-6777
MANITOBA, SASKATCHEWAN and 807 area code in ONTARIO		1-800-665-1683
QUEBEC	Montreal (except South Shore) South Shore Montreal Quebec City Sherbrooke	1-800-361-3032 1-800-361-0950 1-800-463-1523 1-800-567-6966
ATLANTIC PROVINCES		1-800-565-1598

FOR FURTHER ASSISTANCE

If you need further assistance, you can write to Inglis Limited with any questions or concerns at:

Consumer Relations Department
Inglis Limited
1901 Minnesota Court
Mississauga, Ontario L5N 3A7

Please include a daytime phone number in your correspondence.

NOTES

WHIRLPOOL® AUTOMATIC WASHER WARRANTY (U.S.A.)

LENGTH OF WARRANTY	WHIRLPOOL WILL PAY FOR
FULL ONE-YEAR WARRANTY FROM DATE OF PURCHASE	FSP® replacement parts and repair labor to correct defects in materials or workmanship. Service must be provided by an authorized Whirlpool service company.
LIMITED FIVE-YEAR WARRANTY FROM DATE OF PURCHASE	FSP replacement parts for any part of gearcase assembly if defective in materials or workmanship. The gearcase assembly is shown in the "Requesting Assistance or Service" section of this book. FSP replacement parts for any top and lid rust.
LIMITED TEN-YEAR WARRANTY FROM DATE OF PURCHASE	FSP replacement parts for outer tub should it crack, or fail to contain water, due to defective materials or workmanship.
WHIRLPOOL WILL NOT PAY FOR	
<p>A. Service calls to:</p> <ol style="list-style-type: none"> 1. Correct the installation of your washer. 2. Instruct you how to use your washer. 3. Replace house fuses or correct house wiring or plumbing. <p>B. Repairs when your washer is used in other than normal, single-family household use.</p> <p>C. Pickup and delivery. Your washer is designed to be repaired in the home.</p> <p>D. Damage to your washer caused by accident, misuse, fire, flood, acts of God, or use of products not approved by Whirlpool.</p> <p>E. Any labor costs during the limited warranties.</p> <p>F. Replacement parts or repair labor costs for units operated outside the United States.</p> <p>G. Repairs to parts or systems resulting from unauthorized modifications made to the appliance.</p>	

9/97

WHIRLPOOL CORPORATION SHALL NOT BE LIABLE FOR INCIDENTAL OR CONSEQUENTIAL DAMAGES. Some states do not allow the exclusion or limitation of incidental or consequential damages, so this exclusion or limitation may not apply to you. This warranty gives you specific legal rights, and you may also have other rights which vary from state to state.

Outside the United States, a different warranty may apply. For details, please contact your authorized Whirlpool dealer.

If you need assistance or service, first see the "Troubleshooting" section of this book. After checking "Troubleshooting," additional help can be found by checking the "Requesting Assistance or Service" section. In the U.S.A., call our Consumer Assistance Center at **1-800-253-1301**.

For warranty information in Canada:

Please contact your authorized Whirlpool dealer or call the Consumer Assistance Centre at 1-800-461-5681 (toll free) between 8:30 a.m. and 6 p.m. EST from anywhere in Canada.

For assistance or service in Canada:

If you need assistance or service in Canada, first see the "Troubleshooting" section of this book. After checking "Troubleshooting," additional help can be found by checking the "Requesting Assistance or Service" section.