



**MONTERINGSANVISNING · INSTALLATION INSTRUCTIONS
MONTAGEANLEITUNG · INSTRUCTIONS DE MONTAGE**

Saab 9-3 M03-

Engine/cabin heater

Accessories Part No.	Group	Date	Instruction Part No.	Replaces
12 787 161	9:87-42	Jun 02	12 788 928	

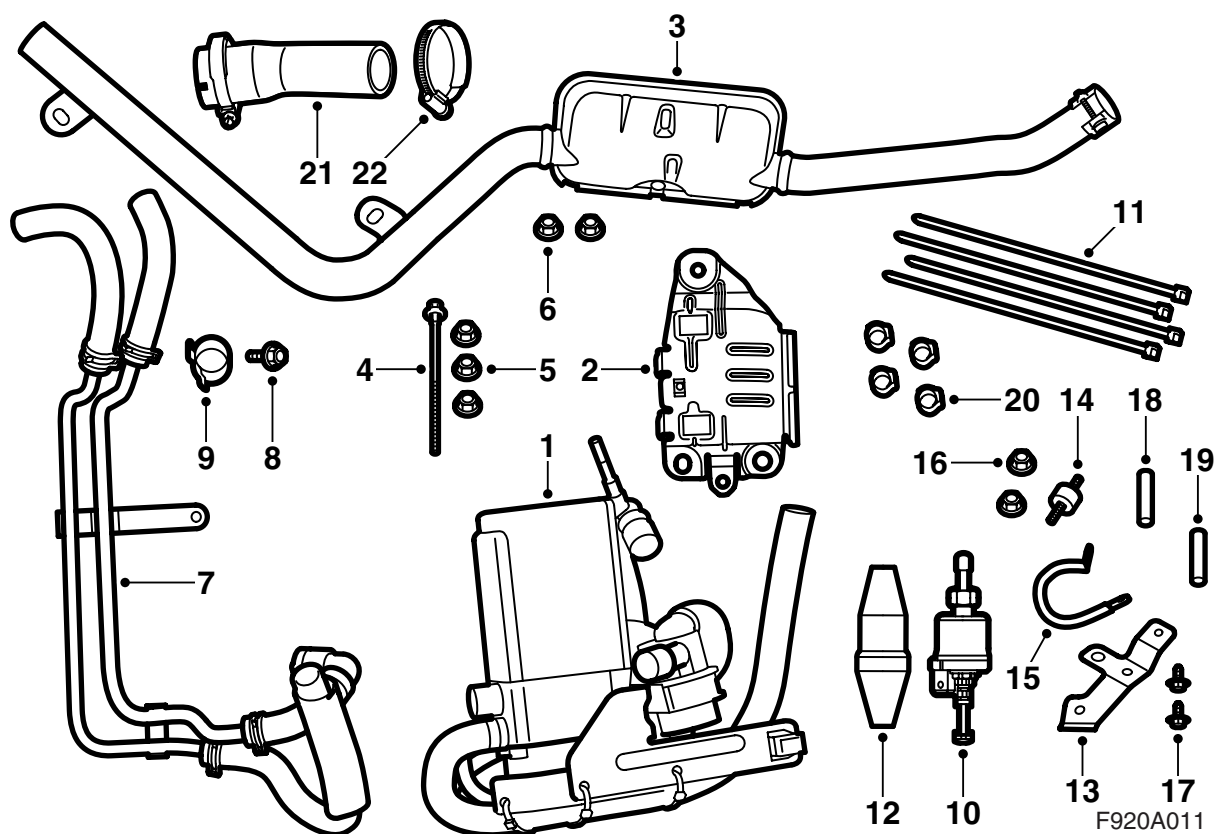

Heater mounting kit

- 1 Petrol heater
- 2 Holder
- 3 Exhaust system
- 4 Bolt M6x100
- 5 Nut M8 (x3)
- 6 Nut M6 (x2)
- 7 Coolant hoses/pipes
- 8 Bolt
- 9 Hose clip (x3)
- 10 Fuel Pump
- 11 Cable tie (x20)
- 12 Protective cover, petrol pump
- 13 Bracket, fuel pump
- 14 Vibration damper
- 15 Clamp
- 16 Nut M6 (x2)
- 17 Screw (x2)
- 18 Joint hose
- 19 Joint hose
- 20 Hose clip, fuel line (x4)
- 21 Hose
- 22 Hose clip (x2) (One is mounted on hose (21))

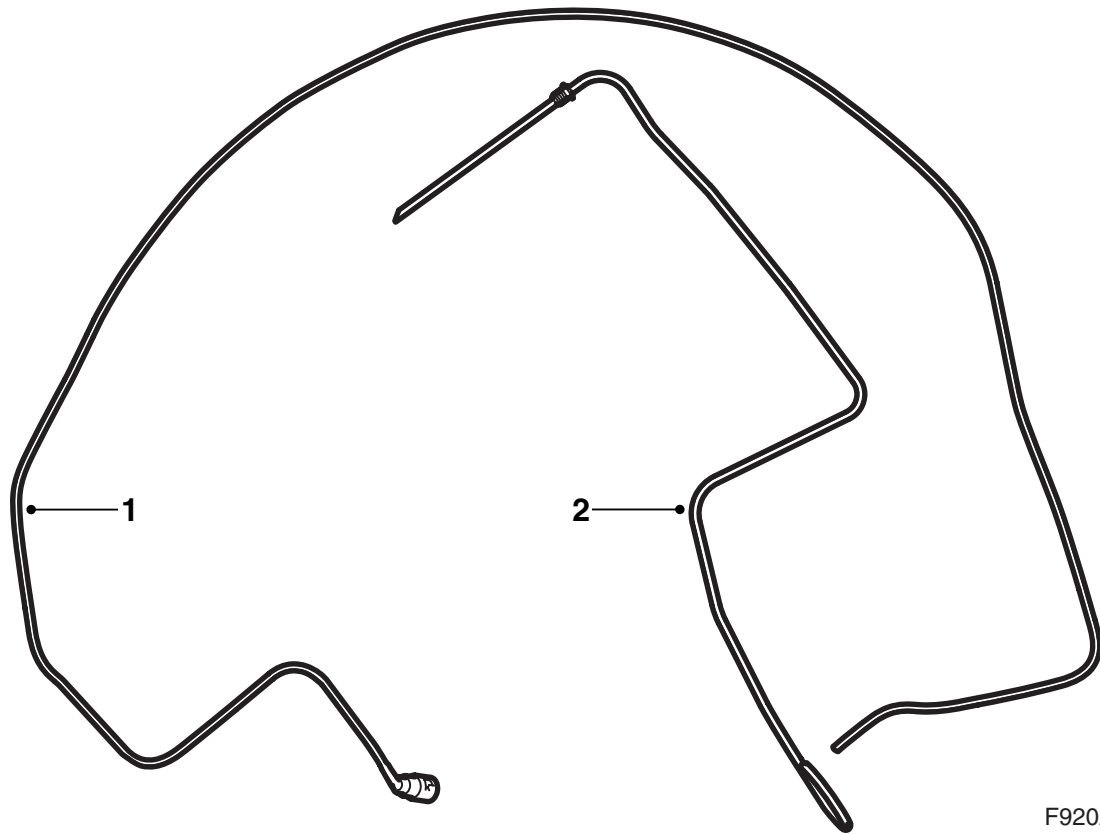

F920A012

Fuel line kit

- 1 Fuel line (pump-heater)
- 2 Fuel line (tank to pump)

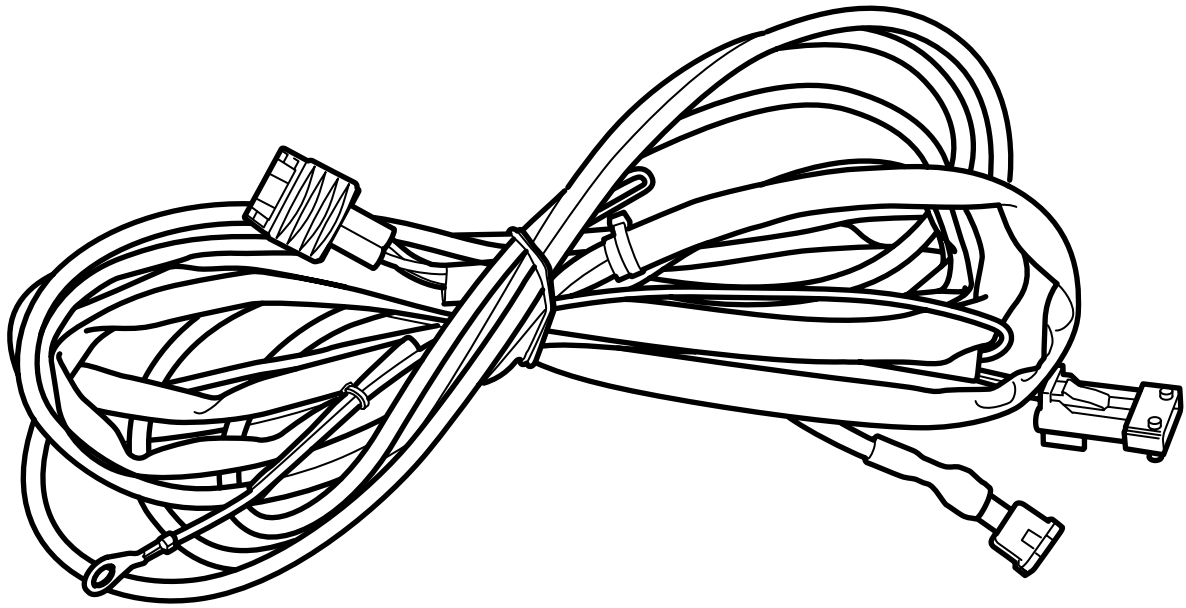

F920A013

Electrical connection kit

Wiring harness

Important

 **WARNING**

Work on the heater involves dismantling the vehicle fuel system and emptying the fuel tank. When carrying out the work the following points should therefore be observed:

- Provide good ventilation! Use approved extractors for removing fuel fumes if they are available.
- Use protective gloves! Prolonged contact with fuel can cause skin irritation.
- Keep a class BE fire extinguisher close at hand. Observe the risk of sparks, e.g. in connection with breaking electrical circuits, short circuiting, etc.
- Smoking is absolutely forbidden.
- Use protective goggles.

Important

The flexible bellows on the forward section of the exhaust system must not be bent more than 5° from its neutral alignment. This means that if the forward section is hanging free, the bellows must not be bent further than the amount already caused by the weight of the system.

Excessive loading of the pipe can lead to residual deformations in the components which can cause noise, leakage and eventually failure.

Preparations

Reduction of fuel pressure

- 1 Let the engine idle.
- 2 Remove fuse No. 2 (fuel pump) from the electrical centre located in front of the battery in the engine compartment.
- 3 When the engine has stopped the ignition key must be turned to the OFF position.
- 4 Refit the fuse.

Emptying the fuel tank

Important

Pay attention to cleanliness when working on the fuel system. Prevent dirt from entering the tank and fuel lines.

Be careful not to damage the non-return valve in the fuel tank when inserting and removing the suction pipe of the emptying unit.

The fuel tank is not fitted with a drain plug. Where work on the fuel system requires emptying of the fuel tank this is done with an emptying unit via the filler pipe.

Before emptying read carefully through the instructions supplied with the emptying unit.

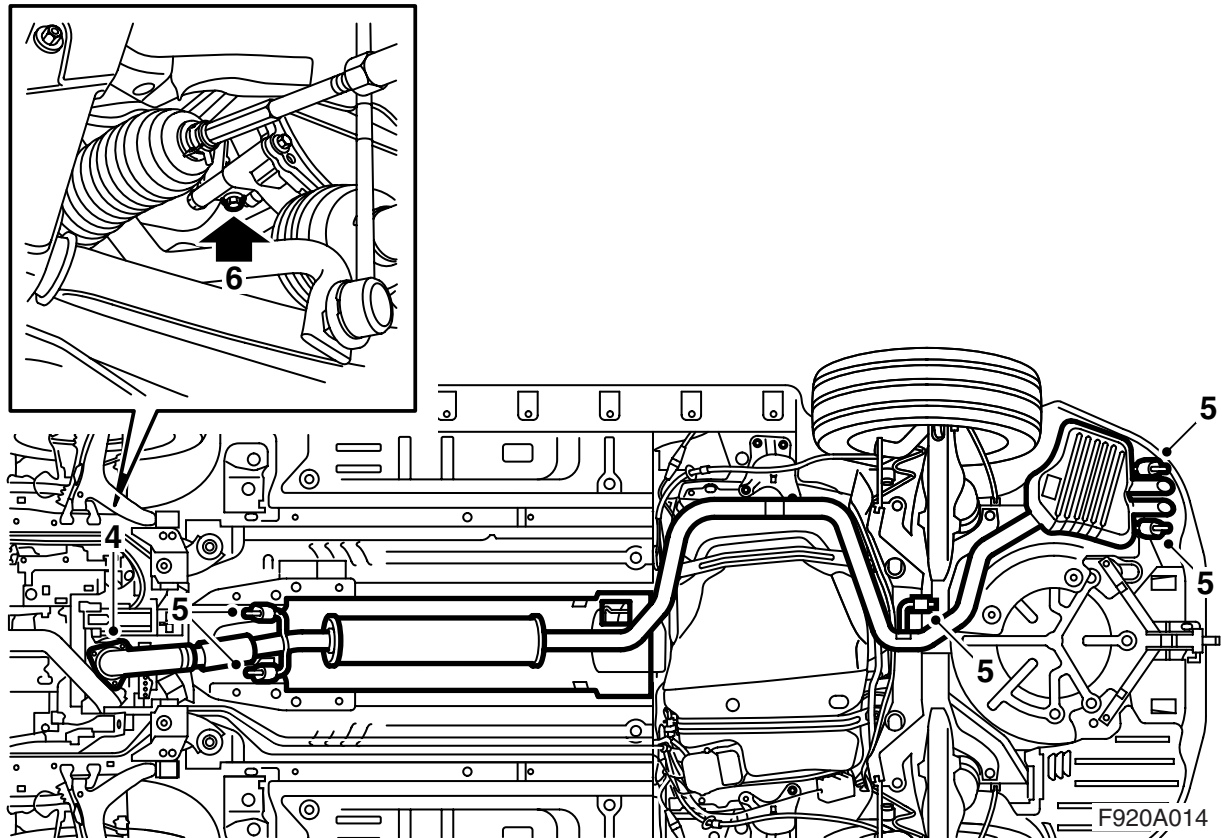

- 1 Disconnect the negative battery cable.
- 2 Remove the cap from the expansion tank.
- 3 Raise the car.
- 4 Remove the bolts from the forward section of the exhaust system.
- 5 Remove the exhaust system.
- 6 Place a receptacle under the engine, open the drain plug on the bottom of the coolant pump and drain the coolant.

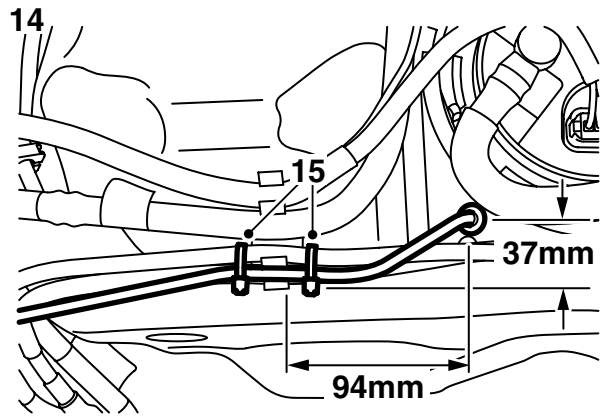
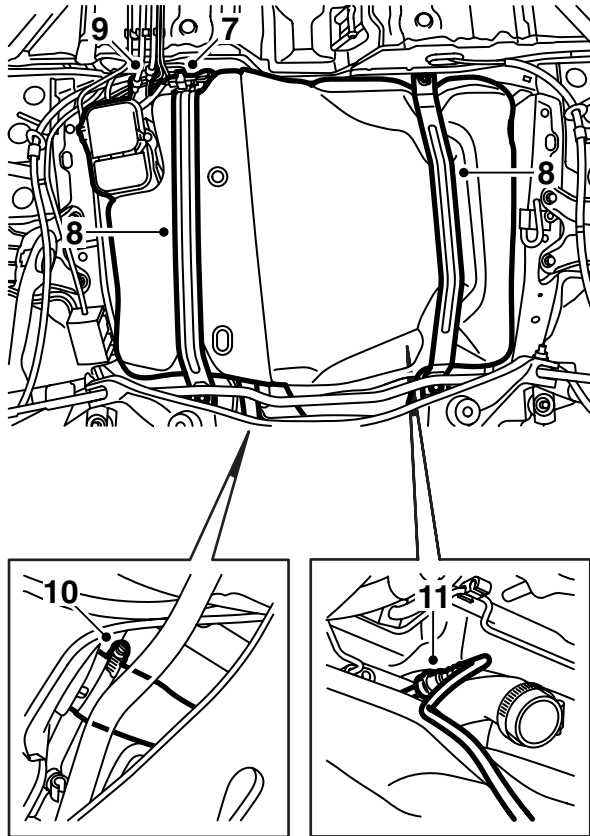

F920A015

- 7 Unplug the connector at the front of the fuel tank and detach the wiring harness from its mounting.
- 8 Place a pillar jack under the fuel tank and undo the tank mounting straps.
- 9 Separate the fuel lines using tool 83 95 261 and plug the fuel line tank connections in order to prevent fuel spill.
- 10 Remove the filler pipe hose from the fuel tank.
- 11 Carefully lower the fuel tank until the joint in the carbon filter vent hose becomes accessible. Separate the joint in the carbon filter vent hose and the joint in the fuel filler vent hose.
- 12 Lower the fuel tank completely and lift away to a work bench.
- 13 Mark the position of the hole where the heater fuel pipe is to be inserted.
- 14 Drill a 10.5 mm hole in the tank.
- 15 Push the fuel pipe into the tank until the seal locates against the tank and fasten the pipe to the other fuel lines with a cable tie on each side of the fuel line holder.
- 16 Remove the hose which is connected to the fuel filler pipe (the hose clip must be split with a saw) and fit the hose from the set.
Tightening torque 4 Nm (3 lbf ft)
- 17 Place the fuel tank on a pillar jack, lift the tank slightly and connect the fuel filler vent hose. Lift the fuel tank completely and connect the remaining fuel lines.
- 18 Fit the fuel tank mounting straps.
Tightening torque 24 Nm (18 lbf ft)
- 19 Plug in the connector at the front of the fuel tank and fit the wiring harness into its mounting.
- 20 Fit the drain plug in the bottom of the coolant pump.
- 21 Lower the vehicle until it is just over the floor.

Important

Be careful to prevent drill swarf from falling into the tank.

- 15 Push the fuel pipe into the tank until the seal locates against the tank and fasten the pipe to the other fuel lines with a cable tie on each side of the fuel line holder.

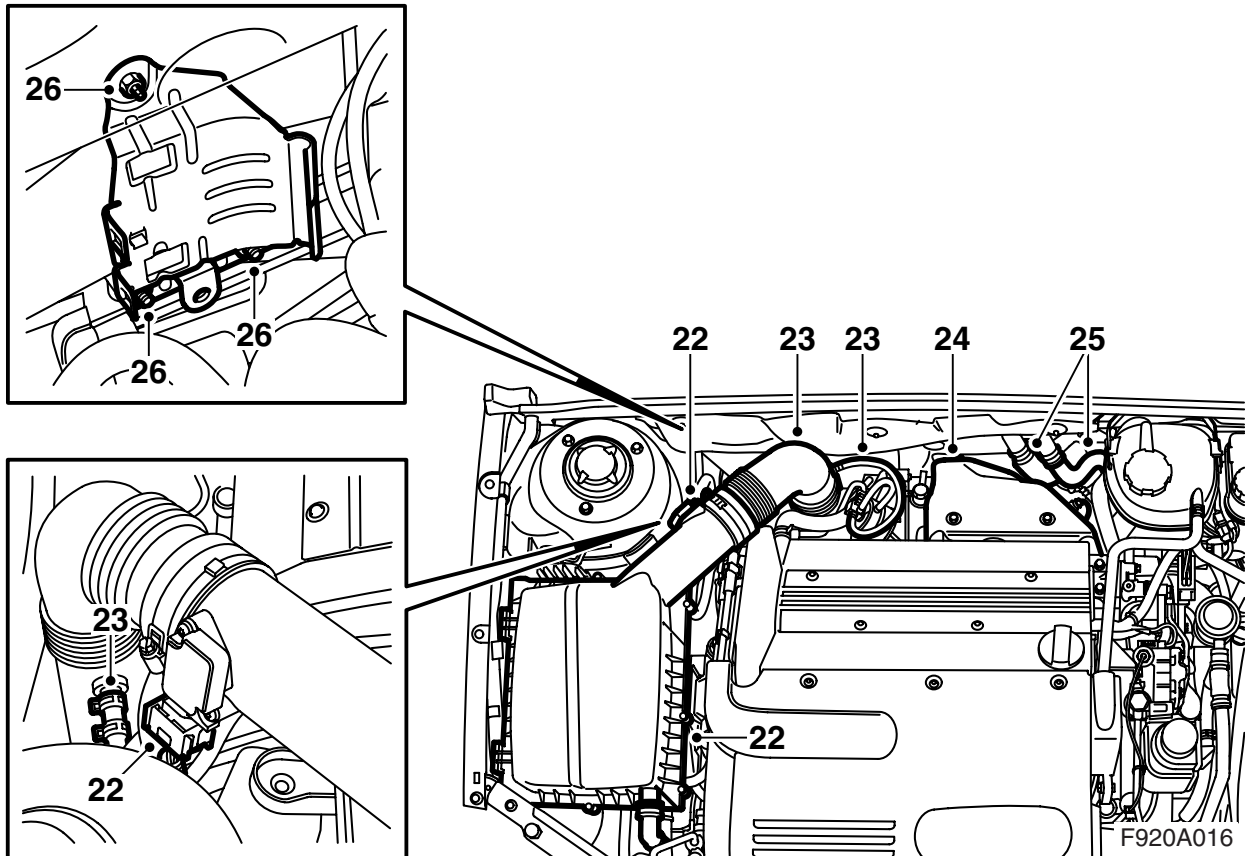

- 22 Unplug the connector from the air mass sensor, separate the intake hose and remove the air filter cover. Remove the hose from the air filter cover (if such a hose is fitted).
- 23 Remove from the turbo intake pipe the small hose to the control valve (APC valve) and the hose to the carbon filter vent-valve. Remove the intake pipe.
- 24 Remove the heat shield from the turbo compressor (two screws and a catch).
- 25 Remove the coolant hoses from the connections to the heat exchanger and remove from the thermostat housing the hose which is nearest to the expansion tank.

Important

Retain the hose clip, it is required for re-assembly.

- 26 Fit the heater mounting bracket to the bulkhead.

Tightening torque 24 Nm (18 lbf ft)

Using benzine, clean an area between the suspension strut mounting bolts on the top of the right-hand suspension turret nearest to the engine. Remove the extra label from the heater and affix it to the cleaned area.

Important

Under no circumstances may this label conceal any part of another label or plate.

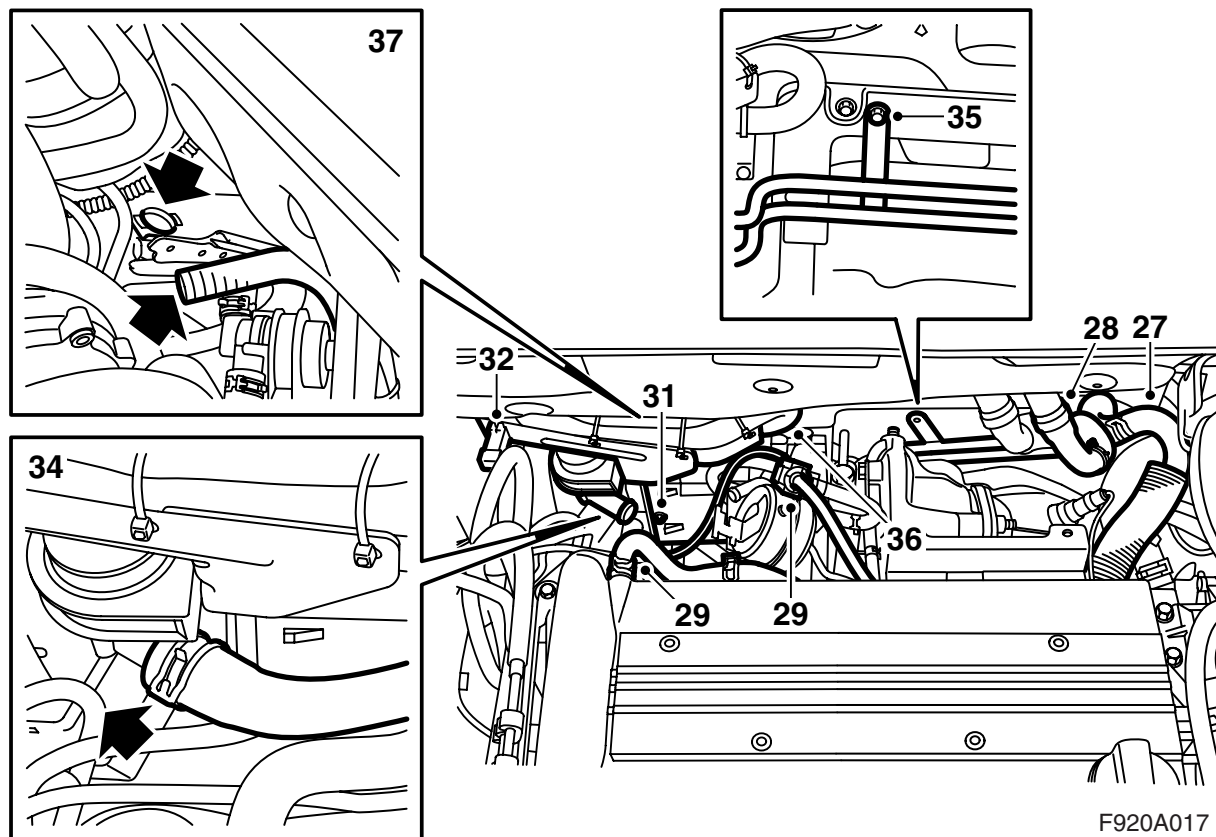

F920A017

27 Fit the hose clips (including the old clip) onto the new coolant hoses. Connect the hose/pipe assembly between the thermostat housing connection and the heat exchanger connection nearest to the expansion tank. Do not screw the assembly to the bulkhead.

Important

The heat shield on the hose should be slid towards the thermostat housing so that the hose clip fits into the cut-out in the heat shield.

- 28 Connect the other coolant hose to the heat exchanger connection.
- 29 Remove the control valve (APC valve) and remove the crankcase ventilation hose from the turbo compressor.
- 30 Remove the plugs from the heater inlet and outlet ports. Push aside the cable tie holding the heater connector and detach the connector from its mounting on the heater.

31 Protect the suspension turret and from above manoeuvre the heater into place on its mounting.

Note

The connector mounting can be bent slightly to facilitate assembly.

Tightening torque 9 Nm (6.5 lbf ft)

Bend the connector mounting back into its original shape.

- 32 Fit the connector into its mounting and reposition the cable tie around the connector.
- 33 Connect the lower coolant hose to the heater and tighten the hose clip.
- 34 Connect the upper coolant hose to the heater and tighten the hose clip.
- 35 Attach the coolant pipe mounting to the brake pipe cover plate on the bulkhead.
- 36 Connect the crankcase ventilation hose to the turbo compressor and fit the control valve (APC valve)
- 37 Connect the inlet hose of the heater to the fixing in the hole in the longitudinal frame member.

Important

Check that the drainage hose is free from the intake hose. If the wiring harness channel on the heater is severely bent the drainage can be affected.

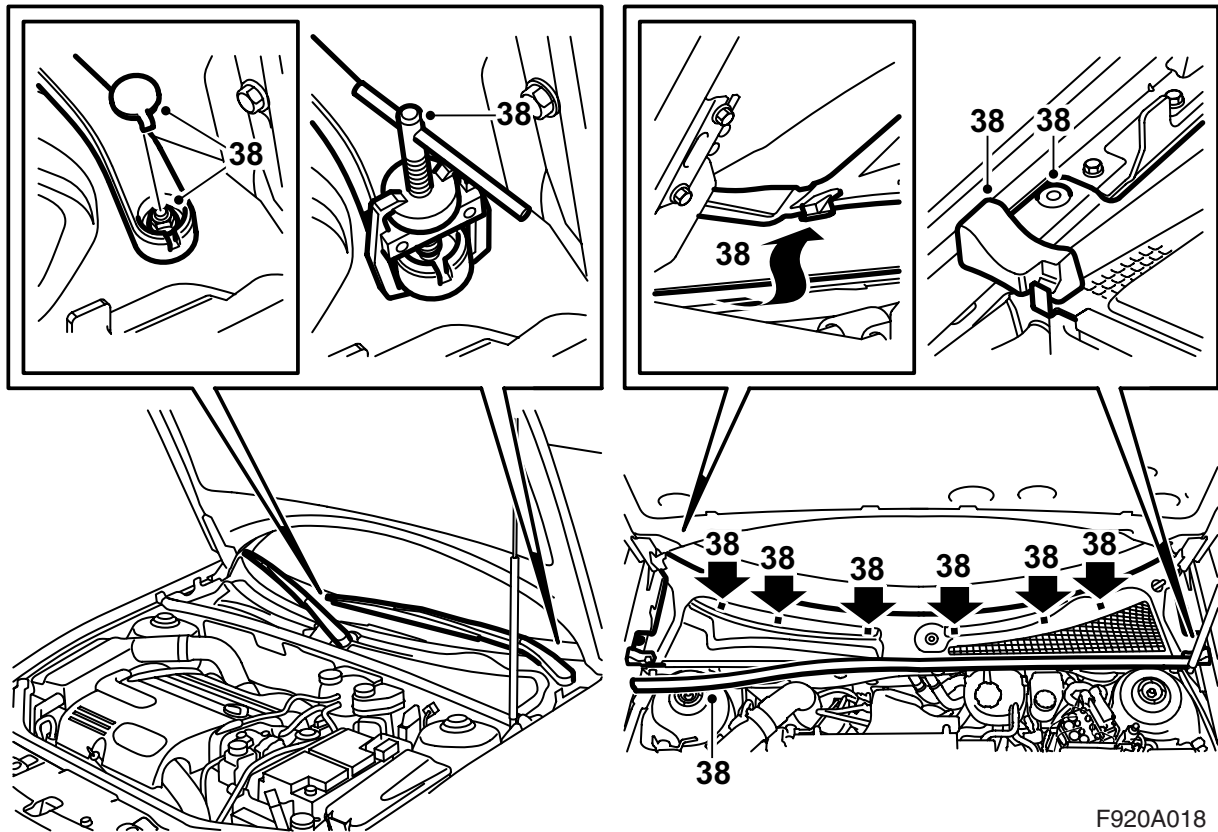

F920A018

- 38 Remove the wiper arms using puller 85 80 144. Remove also the bonnet seal and the cover over the bulkhead space.

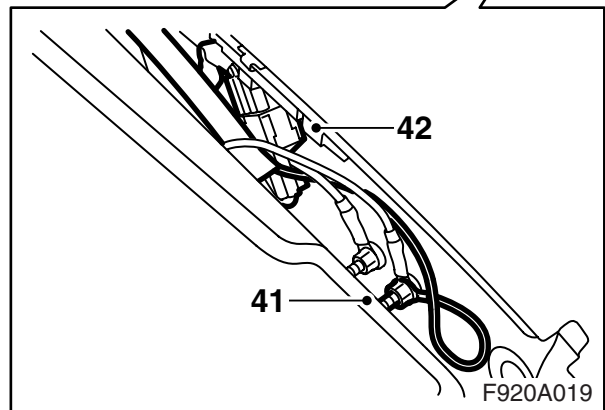
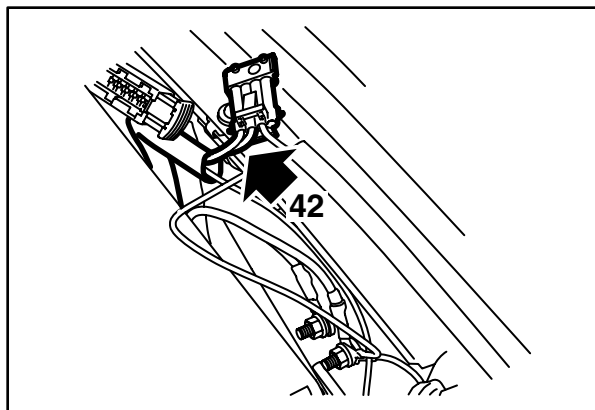
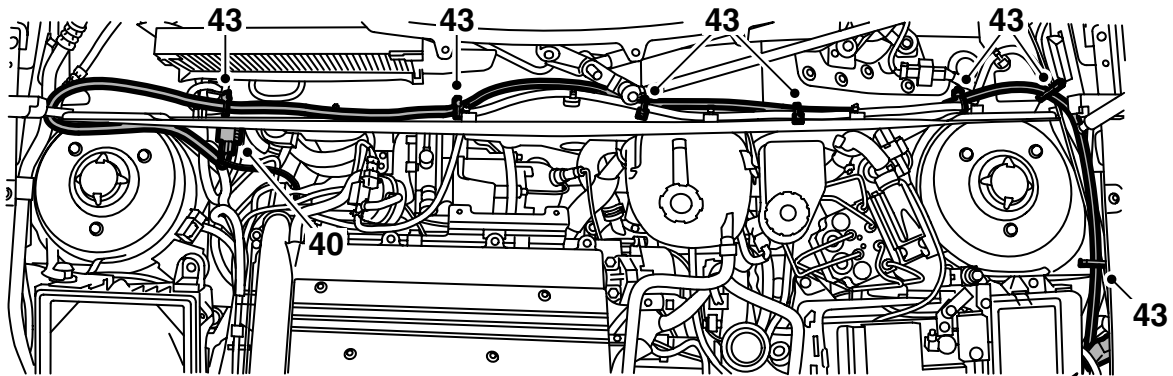

- 39 Locate the "Pre Acc" outlet between the engine bay main fuse box and the front wing and remove any adhesive tape or dummy connector.
- 40 Plug the wiring harness from the installation set into the connector on the heater and route it through the bulkhead space to the "Pre Acc" outlet adjacent to the engine compartment electrical centre.

Important

The wiring harness must be located in the seals by the front wings.

- 41 Connect the ground cable to the front grounding point (G30A) in the engine bay main fuse box.
- 42 Connect the wiring harness to the four pole "Pre Acc" outlet.

Note

If the four pole "Pre Acc" outlet is already used, connect into the existing connector as follows

- Unplug "Pre Acc"
- remove the seal from the connector on the heater wiring harness and detach the cables from the connector block
- fit the cables into the connector which was plugged into "Pre-Acc", red cable (RD) in position 1 and green cable (GN) in position 2
- Plug in the connector to "Pre Acc".

- 43 Fasten the wiring harness with cable ties (x7). Position the "Pre-Acc" outlet between the wiring harness and the front wing.

Important

Check that the drainage hose at the filter is correctly fitted.

- 44 Thread the fuel pump wiring harness down alongside the fuel lines against the back edge of the frame member.

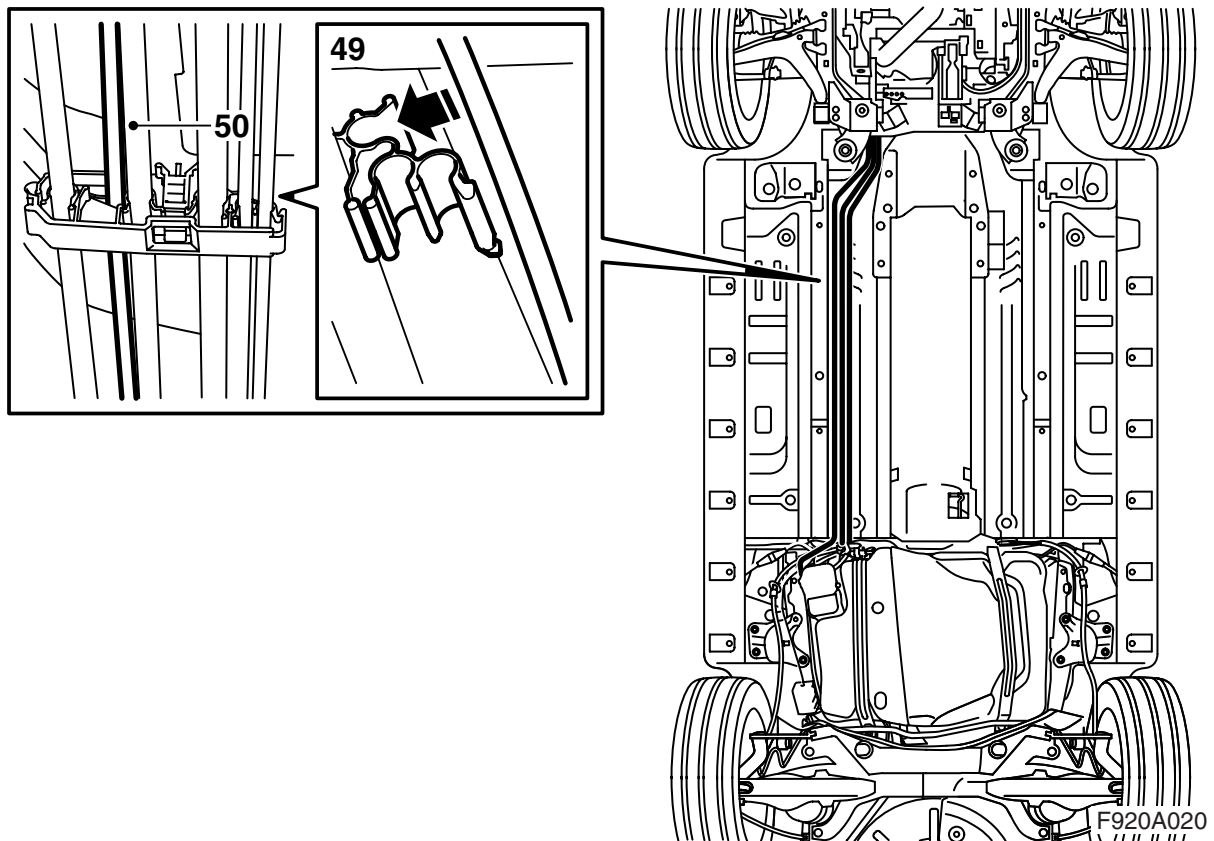

- 45 Raise the car.
- 46 Pull down the fuel pump wiring harness.
- 47 Thread the fuel pump fuel line up between the heater and the longitudinal frame member.
- 48 Connect the fuel line to the heater.
- 49 Fit the fuel pump fuel line into the clips on the underside of the vehicle floor. The fuel line should be located in the upper groove of each clip.
- 50 Open the clips on the underside of the floor and locate the fuel line in the grooves. Close the clips and fasten the fuel line with cable ties (x7) between the clips.

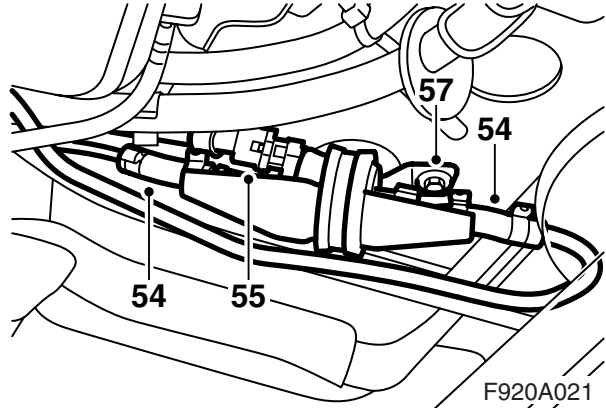
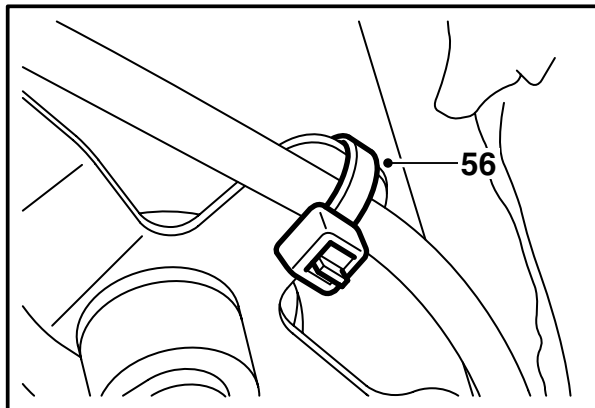
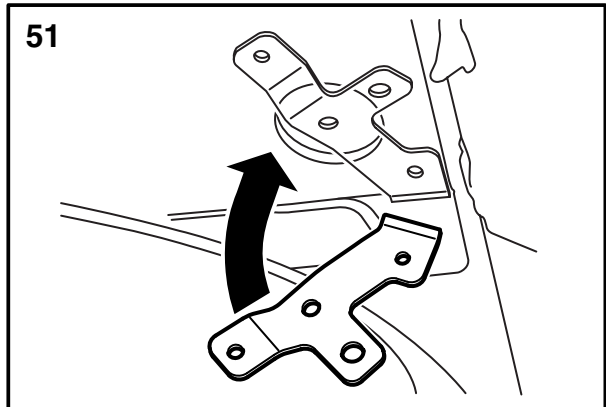
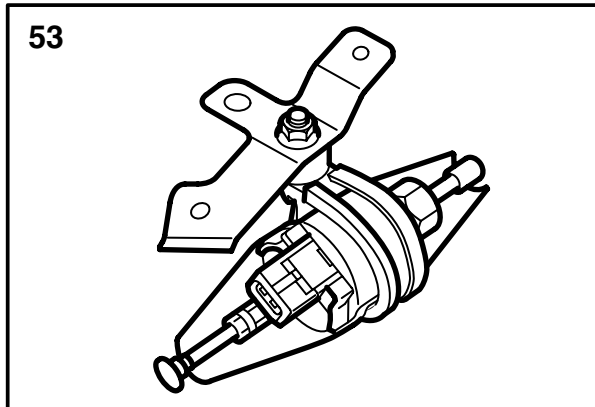

- 51 Position the fuel pump bracket up against the vehicle floor, on the right-hand side in front of the fuel tank, and drill holes using a 3.5 mm drill.
- 52 Deburr the holes and remove loose swarf and paint particles. Clean with Teroson Cleaner FL and apply Standox 1K primer. Apply a finishing coat.
- 53 Fit the fuel pump with vibration damper and protective cover onto the bracket.

Important

The smaller diameter connection should point towards the centre of the car and slightly forwards. The protective cover should be positioned under the pump.

- 54 Connect the fuel lines to the fuel pump using a joint hose and two hose clips for each connection. The joint hose which has a smaller diameter at one end should be arranged so that this end fits onto the smaller diameter connection of the pump. Attach the long fuel line to the pump bracket by threading a cable tie through the hole in the bracket.
- 55 Connect the wiring harness to the fuel pump.
- 56 Attach the harness to the bracket using a cable tie.
- 57 Screw the bracket with the pump assembly onto the floor of the vehicle.

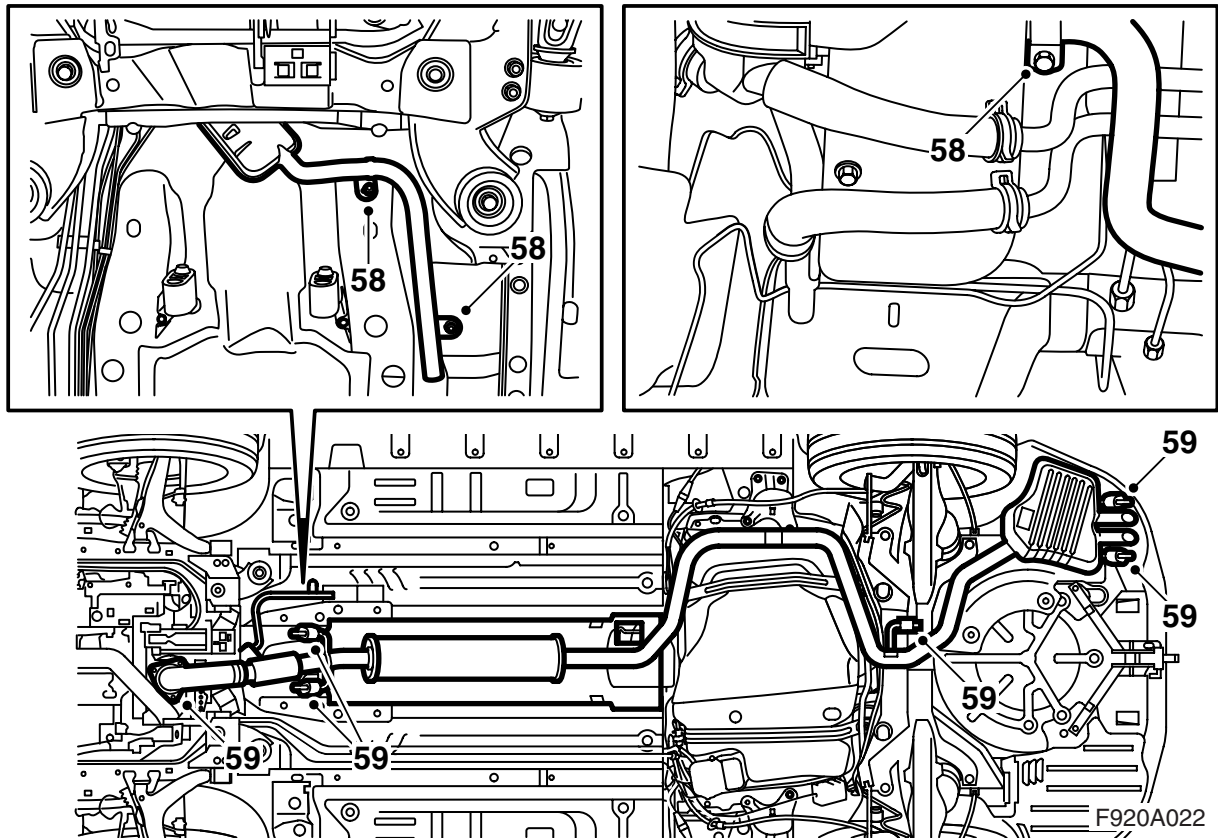

58 Manoeuvre the heater exhaust pipe up towards the heater and fit the end of the pipe onto the exhaust port of the heater. Fasten the exhaust pipe to the floor of the vehicle with the two nuts.

Tightening torque 5 Nm (3.5 lbf ft)

59 Fit the vehicle exhaust system.

Tightening torque 22 Nm (16.5 lbf ft)

60 Lower the vehicle until it is just over the floor.

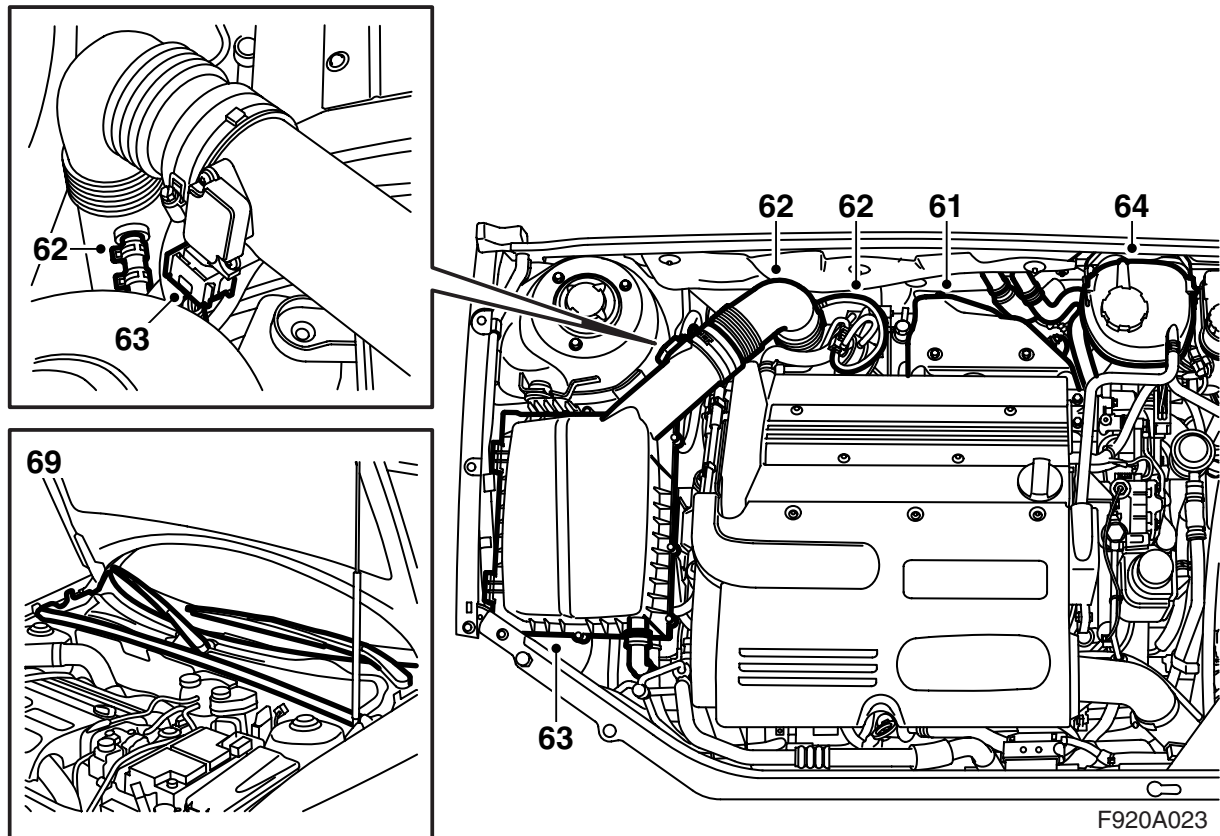

- 61 Fit the heat shield to the turbo compressor (two screws and a catch).
- 62 Fit the turbo intake pipe and then connect to the pipe the small hose from the control valve (APC valve) and the hose from the carbon filter vent valve.
- 63 Fit the air filter cover and plug the connector into the air mass sensor. Attach the hose to the air filter cover (if such a hose is fitted).
- 64 Fill with coolant and check the system for leaks. Fit the expansion tank cap.
- 65 Connect the negative battery cable.
- 66 Connect the diagnostic tool, select car and model year, select "All", select "Add/Remove", select the accessory and then "Add".
- 67 Bleed the cooling system in the following way:

Note

The A/C or ACC should be turned OFF.

Fill the coolant system to the MAX level. Close the expansion tank cap. Start the engine and run at varying engine speeds until the radiator fan cuts in. Carefully open the expansion tank cap and top up to the MAX level. Close the cap. Switch off the engine and if necessary top the coolant up to the MAX level.

- 68 Start the heater by pushing the "CUSTOMIZE" button on the SIDC, select "Parking heater", push "SET", select "Manual control", push "SET", select "Heater on", push "SET" and check that the heater starts (it has a delay of about 1 minute). If necessary top up the cooling system (engine switched off).
- 69 Fit the cover over the bulkhead space, fit the bonnet seal and the wiper arms.
- 70 Adjust the clock/date.
- 71 **Programme the heater** Turn the ignition switch to the ON position, push the "CUSTOMIZE" button on the SIDC, select "Parking heater", push "SET", select "Manual control" and check that the heater starts or select "Timer setting", "Timer", select a timer; "A", "B" or "C", programme in a suitable time and push "SET". Check that the heater starts at the programmed time.

Select "Manual control", press "SET", select "Heater off", press "SET" and check that the heater stops. Select "Back", press "SET", select "Finish" and press "SET".