

1. THE ENVIRONMENT - DISPOSAL INSTRUCTIONS .....	20
2. PRECAUTIONS FOR USE .....	21
3. SAFETY PRECAUTIONS .....	22
4. INSTALLATION AND CONNECTION .....	23
4.1 Positioning and levelling the appliance .....	24
4.2 Electrical connection .....	24
4.3 Overall dimensions .....	24
5. GETTING TO KNOW YOUR APPLIANCE .....	25
6. BEFORE INSTALLATION .....	25
7. OPERATION .....	26
7.1 Electronic controls .....	26
7.2 Temperature display .....	26
7.3 Temperature setting .....	26
7.4 Low-temperature alarm .....	27
7.5 Storage Temperatures .....	27
7.6 Filling the cellar with bottles .....	29
7.7 Practical hints for storing and enjoying wines .....	29
8. ACCESSORIES .....	30
9. CLEANING AND MAINTENANCE .....	30
9.1 Defrosting the wine cellar .....	30
9.2 Cleaning the wine cellar .....	30
9.3 Switching off the wine cellar .....	30
9.4 Operating noises .....	31
9.5 Identifying and Dealing with Malfunctions. ....	32
10. SOME HINTS FOR SAVING MONEY .....	34



**INSTRUCTIONS FOR THE INSTALLER:** *these are intended for the **qualified engineer** who is to install, commission and test the appliance*



**INSTRUCTIONS FOR THE USER:** *these provide recommendations for use, a description of the controls and the correct procedures for cleaning and maintaining the appliance*



## **1. THE ENVIRONMENT - DISPOSAL INSTRUCTIONS**

OUR WINE CELLARS ARE PACKAGED USING NON-POLLUTANT, ENVIRONMENT-FRIENDLY, RECYCLABLE MATERIALS. WE URGE YOU TO COOPERATE BY DISPOSING OF THE PACKAGING PROPERLY. CONTACT YOUR LOCAL DEALER OR THE COMPETENT LOCAL ORGANISATIONS FOR THE ADDRESSES OF COLLECTION, RECYCLING AND DISPOSAL FACILITIES.

NEVER LEAVE ALL OR PARTS OF THE PACKAGING LYING AROUND: PACKAGING PARTS, AND ESPECIALLY PLASTIC BAGS, MAY REPRESENT A SUFFOCATION HAZARD FOR CHILDREN.

**IMPORTANT: YOUR OLD APPLIANCE MUST ALSO BE DISPOSED OF PROPERLY.**

DELIVER THE APPLIANCE TO YOUR LOCAL ORGANISATION AUTHORISED TO COLLECT SCRAPPED APPLIANCES. PROPER DISPOSAL ALLOWS THE INTELLIGENT RECOVERY OF VALUABLE MATERIALS. REFRIGERATION APPLIANCES CONTAIN GASES WHICH MAY DAMAGE THE ENVIRONMENT; IT IS IMPORTANT TO ENSURE THAT THE REFRIGERATION CIRCUIT PIPELINES ARE NOT DAMAGED UNTIL THE COMPETENT SERVICE HAS TAKEN DELIVERY OF THE APPLIANCE.

BEFORE SCRAPPING YOUR APPLIANCE IT IS IMPORTANT TO REMOVE DOORS AND LEAVE SHELVES IN POSITION AS FOR USE, TO ENSURE THAT CHILDREN CANNOT ACCIDENTALLY BECOME TRAPPED INSIDE DURING PLAY. ALSO, CUT THE POWER SUPPLY LEAD AND REMOVE IT AND THE PLUG.

**BY LAW, APPLIANCES MUST ONLY BE DISPOSED OF AT SUITABLY EQUIPPED FACILITIES.**

## 2. PRECAUTIONS FOR USE



ELECTRICAL CONNECTION: SEE INSTALLATION INSTRUCTIONS FOR SAFETY REGULATIONS FOR ELECTRIC OR GAS APPLIANCES AND FOR VENTILATION FUNCTIONS.

IN YOUR INTEREST AND TO ENSURE YOUR SAFETY, BY LAW ALL ELECTRIC APPLIANCES MUST ONLY BE INSTALLED AND SERVICED BY QUALIFIED STAFF, IN ACCORDANCE WITH THE RELEVANT REGULATIONS.

GAS OR ELECTRIC APPLIANCES MUST ALWAYS BE DISCONNECTED BY SUITABLY SKILLED PEOPLE.



THIS MANUAL CONSTITUTES AN INTEGRAL PART OF THE APPLIANCE: TAKE GOOD CARE OF IT AND KEEP IT TO HAND THROUGHOUT THE APPLIANCE'S LIFE CYCLE. **WE URGE YOU TO READ THIS MANUAL AND ALL THE INFORMATION IT CONTAINS CAREFULLY BEFORE USING THE APPLIANCE. INSTALLATION MUST BE CARRIED OUT BY QUALIFIED STAFF IN COMPLIANCE WITH THE RELEVANT REGULATIONS.** THIS APPLIANCE IS INTENDED FOR HOUSEHOLD USE AND COMPLIES WITH THE **EEC DIRECTIVES** CURRENTLY IN FORCE. THE APPLIANCE IS BUILT TO PROVIDE THE FOLLOWING FUNCTION: **COOLING OF DRINKS**; ALL OTHER USES ARE TO BE CONSIDERED IMPROPER.

**THE MANUFACTURER DECLINES ALL LIABILITY FOR USES OTHER THAN THOSE STATED ABOVE.**



NEVER USE THIS APPLIANCE FOR COOLING ROOMS.



THIS APPLIANCE IS TAGGED UNDER EUROPEAN DIRECTIVE 2002/96/EC ON WASTE ELECTRICAL AND ELECTRONIC EQUIPMENT (WEEE).

THIS DIRECTIVE CONTAINS THE REGULATIONS GOVERNING THE COLLECTION AND RECYCLING OF DECOMMISSIONED APPLIANCES THROUGHOUT THE EUROPEAN UNION.



NEVER OBSTRUCT THE OPENINGS AND SLITS PROVIDED FOR VENTILATION AND HEAT DISPERSAL.



SETTING THE THERMOSTATS TOO LOW IN SUMMER CAUSES CONSIDERABLY INCREASED ICE FORMATION ON THE BACK OF THE APPLIANCE, SIGNIFICANTLY REDUCING ITS EFFICIENCY. DURING THE SUMMER OR WHENEVER THE WEATHER IS PARTICULARLY HOT AND/OR HUMID, THE WINE CELLAR SHOULD BE KEPT AT A FAIRLY HIGH SETTING TO PREVENT ICE FROM BUILDING UP IN THE BACK OF THE INTERIOR, CAUSING LOSS OF EFFICIENCY.



DURING OPERATION, THE APPLIANCE'S REAR SURFACE MAY HEAT UP CONSIDERABLY; THIS IS QUITE NORMAL AND DOES NOT INDICATE A MALFUNCTION.



THE NAMEPLATE WITH THE TECHNICAL DATA, SERIAL NUMBER AND MARKING ARE IN THE BOTTOM LEFT-HAND CORNER OF THE WINE CELLAR'S INTERIOR.

**THE NAMEPLATE MUST NEVER BE REMOVED.**



IT IS BEST TO OPEN THE DOOR AS LITTLE AS POSSIBLE, PARTICULARLY IN HOT WEATHER. OPENING THE DOOR OFTEN OR LEAVING IT OPEN WILL CAUSE VARIATIONS IN TEMPERATURE INSIDE THE APPLIANCE WHICH MIGHT LEAD DETERIORATION OF THE WINE'S CONDITION.



*The manufacturer declines all responsibility for injury or damage caused by failure to comply with the above regulations or deriving from tampering with even just one part of the appliance and the use of non-original spare parts.*

### 3. SAFETY PRECAUTIONS

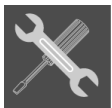

**INSTRUCTIONS FOR THE INSTALLER:** THESE ARE INTENDED FOR THE QUALIFIED ENGINEER WHO IS TO INSTALL, COMMISSION AND TEST THE APPLIANCE.



THE APPLIANCE MUST BE TRANSPORTED IN ITS PACKAGING BY AT LEAST TWO PEOPLE AND INSTALLED BY QUALIFIED STAFF TO PREVENT DAMAGE OR INJURY.



THE REFRIGERANT IN THE APPLIANCE'S CIRCUIT IS OF R134 a.TYPE.



THE REFRIGERANT IS ALSO HARMFUL TO THE EYES: TAKE GREAT CARE IN CASE OF LEAKS FROM THE REFRIGERATION CIRCUIT.

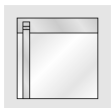

NEVER ATTEMPT TO MOVE THE APPLIANCE BY PULLING ON THE DOOR OR THE HANDLE. TAKE CARE THAT THE DOOR DOES NOT CLOSE AGAIN, TRAPPING YOUR FINGERS.



ON INSTALLATION, IF ANY MANUFACTURING DEFECTS OR DAMAGE CAUSED IN TRANSIT ARE NOTED, CALL YOUR NEAREST SERVICE CENTRE AT ONCE.



FOR INSTALLATION AND CONNECTION, FOLLOW THE INSTRUCTIONS PROVIDED IN THIS MANUAL ONLY.

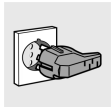

IN CASE OF MALFUNCTIONS, DISCONNECT THE APPLIANCE FROM THE POWER SUPPLY BY REMOVING THE PLUG, WITHOUT PULLING ON THE POWER SUPPLY LEAD.



ALL REPAIRS OR OTHER WORK NOT COVERED BY THIS MANUAL MUST BE CARRIED OUT BY A QUALIFIED ENGINEER, TO BE FOUND AT AN AUTHORISED SERVICE CENTRE. **NEVER ATTEMPT TO REPAIR THE APPLIANCE YOURSELF.**



NEVER STORE SPRAY CANS CONTAINING FLAMMABLE GASES INSIDE THE APPLIANCE. ANY LEAKS MAY CONSTITUTE A SERIOUS THREAT TO USERS' SAFETY.



THE USE OF ELECTRICAL APPLIANCES (SUCH AS ICE-CREAM MAKERS OR WHISKS) INSIDE THE APPLIANCE IS FORBIDDEN.

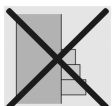

NEVER LEAN ON THE APPLIANCE'S SHELVES AND DRAWERS OR USE THEM AS STEPS.



THE APPLIANCE IS INTENDED FOR USE BY ADULTS KEEP CHILDREN AT A SAFE DISTANCE AND NEVER ALLOW THEM TO PLAY WITH IT.



## 4. INSTALLATION AND CONNECTION

Always place the wine cellar in a dry place with satisfactory ventilation. Never expose it to direct sunlight or install it outdoors. Depending on its climate class (stated on the nameplate inside), the wine cellar can be used in different temperature conditions:

Class	Ambient temperature
SN (Subnormal)	from + 10° C to + 32° C
N (Normal)	from + 16° C to + 32° C
ST (Subtropical)	from + 18° C to + 38° C
T (Tropical)	from + 18° C to + 43° C

Never place the wine cellar close to heat sources unless strictly necessary. If this is unavoidable, a suitable insulating panel must be used to allow the appliance to function properly. Otherwise, place the appliance at least 3 cm from electric or gas cookers and at least 30 cm from combustion or radiation heating systems.

To allow proper cooling of the condenser, the wine cellar must not be placed too close to the wall. Leave a gap of at least 5 cm between the back of the appliance and the wall. There must be an opening of at least 200 cm<sup>2</sup> behind the wine cellar. If the wine cellar is installed underneath a wall cupboard, the distance between the two must be at least 5 cm.

Take care not to scratch or damage the floor when installing the appliance on parquet or linoleum.

The surface on which the appliance is to be placed must be level. Do not use a frame or similar.

The appliance can be installed as a freestanding unit against a wall, built into a kitchen element, or lined up with other appliances (see figures below).

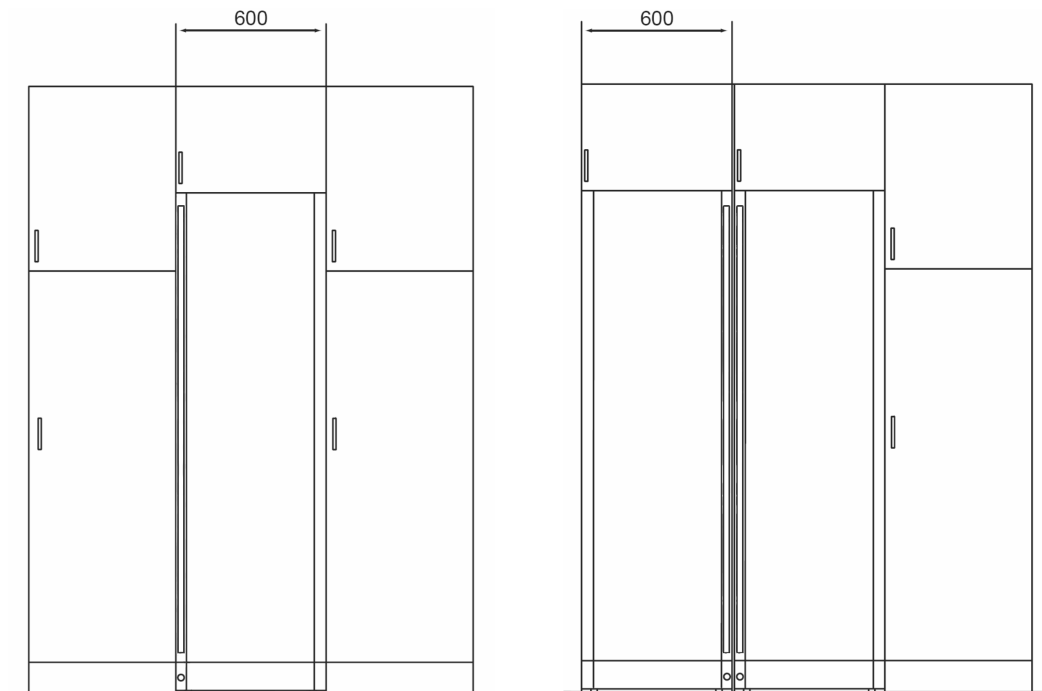



#### 4.1 Positioning and levelling the appliance

Place the wine cellar on a firm, level surface. To compensate for any unevenness in the floor, the appliance has 2 adjustable feet. To adjust them, turn the screw as shown in figure 1 to level the appliance.

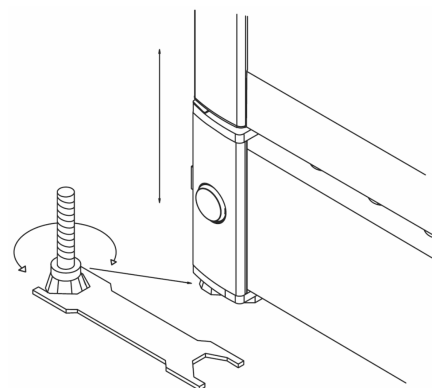

#### 4.2 Electrical connection

Before switching the wine cellar on for the first time, leave it standing upright for about two hours. Then connect the appliance's power supply lead to a mains socket with earth contact, installed in accordance with electrical safety regulations. The rated voltage and frequency are stated on the nameplate inside the wine cellar. The appliance must be connected to the electrical mains and earthed in compliance with the relevant regulations and requirements. The appliance is able to withstand brief voltage fluctuations of not more than 15% below or 10% above the rated value. If the power supply lead has to be replaced, this operation must only be carried out by an authorised Smeg technical service engineer.

#### 4.3 Overall dimensions

The drawing below shows the appliance's maximum overall dimensions with the door open.

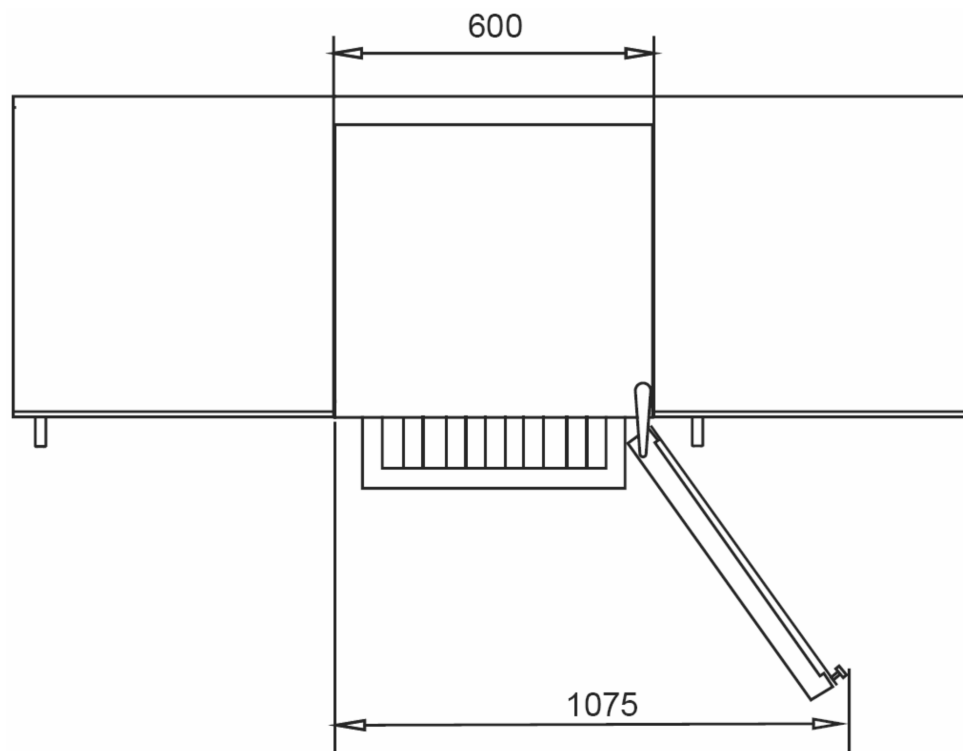



## 5. GETTING TO KNOW YOUR APPLIANCE

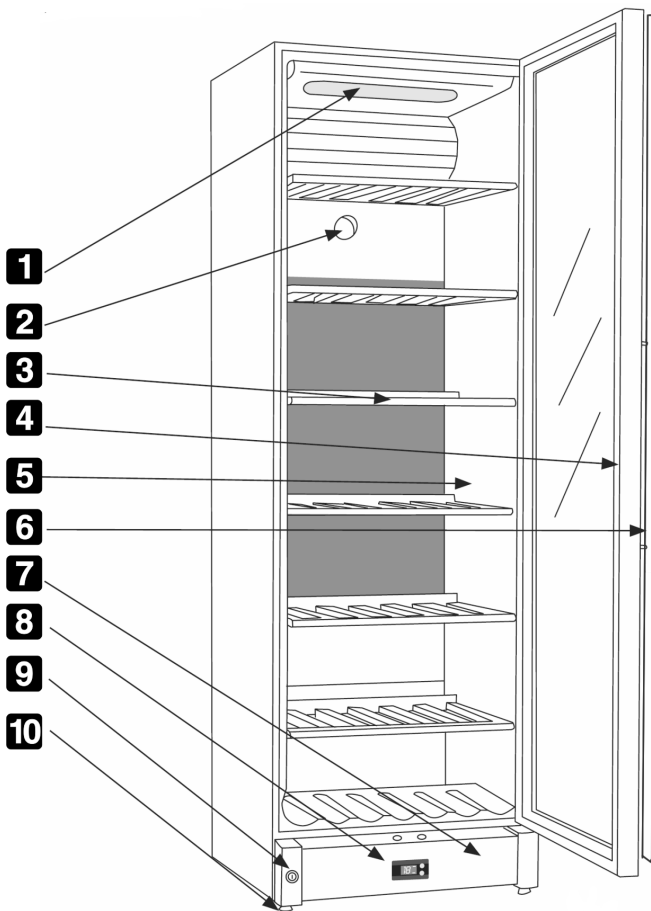

- 1** INTERIOR LIGHT
- 2** ACTIVATED CARBON FILTER
- 3** WOODEN SHELVES
- 4** SEAL
- 5** DATAPLATE
- 6** DOOR HANDLE
- 7** KICK PLATE
- 8** CONTROL PANEL
- 9** LOCK
- 10** ADJUSTABLE FEET

## 6. BEFORE INSTALLATION



Never leave packaging residues unattended in the home. Separate waste packaging materials by type and consign them to the nearest separate disposal centre.



The inside of the appliance should be cleaned to remove all manufacturing residues. For further information about cleaning, see "9. Cleaning and maintenance".

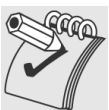

On first use or after a lengthy power blackout, the appliance should be run for about 2 hours before bottles are placed inside.



## 7. OPERATION

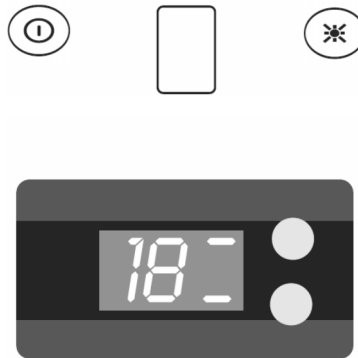

### 7.1 Electronic controls

The electronic controls ensure that the set temperatures are maintained at the top and bottom of the cabinet. This is accomplished by complex control of the refrigerating system, the heating element and the fan.

Following any power failure, the temperature settings are automatically recalled.

The electronic controls have the following functions:

- Temperature setting
- Temperature display
- Automatic defrosting
- Troubleshooting, emergency and service programs
- Low-temperature alarm

① On/off switch

\* The light switch is used to select either continuous illumination or illumination only when the door is opened.

### 7.2 Temperature display

The display shows the actual temperature at the top or bottom of the cabinet. To switch the display between the top and bottom sections, short-press the top and bottom buttons respectively, which section is shown is indicated by a line of light in the display just beside the buttons. The temperature display has a built-in filter that simulates the actual temperature in the bottles. The displayed temperature is therefore not affected by transient fluctuations in air temperature.

### 7.3 Temperature setting

The temperature is set using the two buttons on the control panel. The upper button is used to set the temperature at the top of the cabinet. The lower button is used to set the temperature at the bottom.

Deactivate the childproof lock by pressing the button for 3 seconds. The display then starts flashing and shows the current temperature setting for the zone concerned.

This applies to both buttons/sections. When the display starts flashing, the temperature can be set by scrolling the setting between 22 and 5°C. When the desired setting is displayed, release the button for 3 seconds. The setting will then be stored and the childproof lock reactivated.

**Note that the bottom section cannot be given a higher temperature setting than the top section.**

The highest available temperature setting for the bottom section is therefore identical to the actual setting for the top section.





### 7.4 Low-temperature alarm

If the temperature has been below 2°C for more than 1 hour, the display flashes and Lo/actual temperature are alternately shown. Wine cannot mature properly at sub-zero temperatures.

**Two-zone setting for serving temperature** Typical serving temperature settings for the top and bottom sections are 16°C and 6°C respectively. With these settings, a suitable temperature gradient will be achieved in the cabinet for the storage of various types of wine distributed from top to bottom.

It is recommended that wine be served at a temperature which is a couple of degrees lower than the desired drinking temperature as the wine will be warmed slightly when it is poured into the glass.

**Single-zone setting for long-term storage** For long-term wine storage, the top and bottom sections should both be set at 12°C. With identical settings for the top and bottom sections, the controls will maintain an even temperature throughout the cabinet. However, the temperature in the room will gradually affect the temperature in the cabinet through its door and sides, creating a slight temperature gradient from top to bottom. The controls will maintain the set temperature at the bottom of the cabinet, and any deviation from the setting will therefore occur at the top. The difference will vary from 0 to 3°C, depending on the ambient temperature.

### 7.5 Storage Temperatures

As you will certainly already know, to enjoy the flavour and bouquet of each wine at its best, it should be stored and drunk at a specific temperature. The following table lists these temperatures in relation to the type of wine.

WINE	TEMPERATURE
Young whites	10° - 12° C
Mature whites	12° - 14° C
Young, light rosés	10° - 12° C
Mature, full-bodied rosés	12° - 14° C
Nouveau reds	10° - 14° C
Young, light reds with low tannin	14° - 16° C
Mature, full-bodied reds with high tannin	16° - 18° C
Very mature and cask-aged reds	16° - 18° C
Sweet and aromatic sparkling wines	8° C
Sweet and aromatic red sparkling wines	10° - 12° C
“Charmat method” sparkling wines	8° - 10° C
“Long Charmat method” sparkling wines	10° - 12° C
“Traditional method” sparkling wines without year	8° - 10° C
“Traditional method” sparkling wines with year	10° - 12° C
Dessert wines	10° - 18° C
Fortified or liqueur wines	10° - 18° C



### 7.5.1 White wines

White wines are generally more acidic than reds and contain less tannin.

To be enjoyed at its best, an acidic drink should usually be stored at a slightly lower temperature than other types, and so these wines should be stored at a temperature between 10°C and 14°C.

Young, fresh, aromatic white wines can be served at a temperature as low as 10°C, while for less aromatic wines 12°C is recommended. For full, mature white wines which have aged in the bottle for a few years, higher temperatures are acceptable and they can be served at between 12°C and 14°C.

Serving a white wine at a higher temperature means emphasising its “sweet” properties, while the acidity and sharpness considered pleasant and desirable in wines of this kind will be less noticeable.

### 7.5.2 Rosé wines

Generally, the rules for serving rosé wines are the same as for whites. However, it is important to consider these wines' tannin content and serve them at a higher temperature if necessary so that their flavour is not too sharp. Tannin content permitting, young, fresh rosé wines are served between 10°C and 12°C, while more robust, full-bodied types, including more mature wines, can be served between 12°C and 14°C.

### 7.5.3 Red wines

The serving temperature for red wines depends on a great deal of factors, but in view of their higher tannin and lower acidity than whites, they are usually served at higher temperatures. Young red wines with low tannin are usually served between 14° and 16°C, while for more full-bodied types 16°C or in exceptional cases even 18°C may be recommended.

Young, red wines with low tannin and a fairly uncomplicated structure can be served at between 12°C and 14°C without tasting too sharp, and will still be very pleasant. This rule certainly applies to “nouveau” wines, made by a special method which reduces their tannin content; they can be appreciated to the full at cooler temperatures than other red wines.

### 7.5.4 Sparkling wines

In view of large number of types of sparkling wines on the market, there would be little sense in laying down one rule to fit them all. Sweet, aromatic white sparkling wines can be served at a temperature as low as 8°C; their aromatic nature means they are excellent at low temperatures.

Sweet red sparkling wines such as Brachetto may be served at temperatures between 10°C and 12°C; here again, the more aromatic sparkling wines are suitable for lower temperatures, even down to 8°C, while those with a slightly higher tannin content require temperatures as high as 14°C.

Dry sparkling wines made by the “Charmat method” or “Martinotti method”, such as some Prosecco wines, can be served at temperatures between 8°C and 10°C.

Sparkling wines made by the “traditional method” and the “méthode Champenoise”, such as Champagne, require special consideration. In general these sparkling wines are served at temperatures between 8°C and 10°C. However, for prestige wines marked with the vintage, or sparkling wines that have been aged for a long time, even 12°C may be advisable to allow the development of the complex bouquet that has been slowly and painstakingly built up over the years.

### 7.5.5 Dessert wines and fortified wines

These two types of wine generally both contain a high alcohol percentage and they are both often also sweet. However, there are dry dessert wines, such as Marsala, with a sugar content so low as to be almost imperceptible on the palate. For these wines, the serving temperature depends on which features you wish to emphasise. If you prefer to accentuate the wine's sweetness, the complexity of its bouquet and its austerity, it should be served at a high temperature, between 14°C and 18°C; remember that in this case its alcohol content will also be more in evidence.

If you require a fresher sensation, or to reduce the sweetness of over-sweet wines, serve at a lower temperature, between 10°C and 14°C.

Young, fresh, dry dessert wines can be served at colder temperatures, below 10°C, this makes the alcohol content considerably less noticeable. However, remember that as the temperature is reduced the bouquet also becomes less evident. One of these wines' key characteristics is the charm and complexity of their bouquet; serving them too cold also means sacrificing this important feature.



## 7.6 Filling the cellar with bottles

The cellar's shelves are able to take up to **198** Bordeaux bottles of **750 ml**, depending on the storage method used. The diagrams below show two traditional methods for storing 3/4 litre bottles. Arrangement A gives a capacity of 115 bottles, while with arrangement B the cellar can take up to 198 bottles.

If the bottles are of different shapes and sizes, this number may be smaller.

To ensure the circulation of air through the cellar is not obstructed, the bottles must be placed so that their bottoms do not touch the rear wall.

If you wish to place hot bottles inside the appliance, cool them to room temperature before doing so.

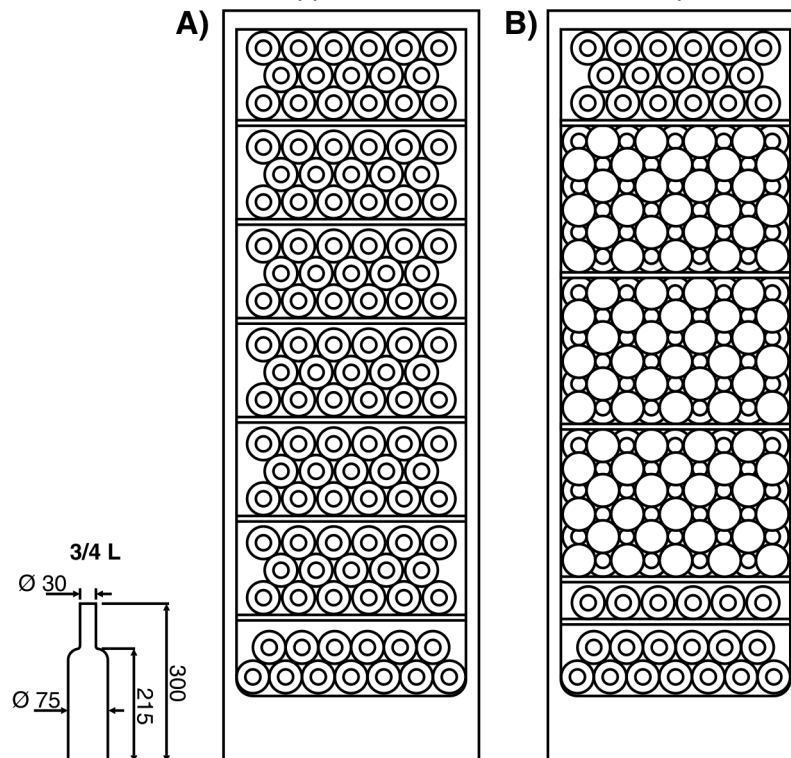

## 7.7 Practical hints for storing and enjoying wines

- Wines in the bottle must always be stored out of their original packaging (boxes or crates);
- Once opened, bottles must be placed so that the wine covers the whole of the cork. There must be no air between the cork and the liquid;
- Before serving, wine should be brought slowly to the ideal serving temperature: for example, a rosé should be placed on the table about 2-3 hours before serving and a red 3-4 hours before. White wine should be served straight from the refrigerator. Sparkling wines and Champagne should be chilled in the refrigerator a short time before serving.



## 8. ACCESSORIES

### Spacers

The spacer on the rear of the appliance assures satisfactory air circulation. Close the cap on itself and secure it at the top.

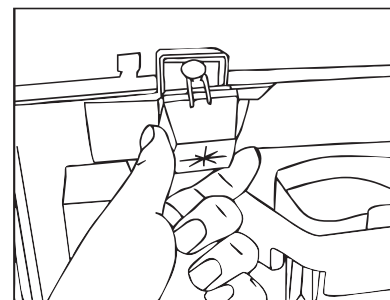

## 9. CLEANING AND MAINTENANCE

*Before carrying out any operations, disconnect the appliance from the electricity supply.*



### 9.1 Defrosting the wine cellar

The wine cellar has automatic defrosting. During normal operation of the appliance, frost forms on its rear wall when the compressor is working and melts when it is not in operation. When the compressor is not working, the frost which has built up on the back wall melts and the water flows into the opening provided in the bottom of the body of the refrigerator. From here, it flows into the tray on the compressor, where it evaporates.

**Warning:** the amount of ice which forms on the rear wall may vary with changes in weather conditions (temperature and humidity), the frequency with which the door is opened, the appliance's operating temperatures and the number of bottles stored inside.

*The formation of condensation on the inside surfaces of the wine cellar during normal use is quite normal and does not indicate a malfunction.*



### 9.2 Cleaning the wine cellar

Before cleaning, disconnect the plug from the electrical mains. Clean the outside using only water and a gentle liquid detergent or an ordinary detergent for washable surfaces (such as a window-cleaning product). Never use products containing abrasives or substances which may attack the lacquered or painted parts, acids or chemical solvents. Use a sponge or a soft cloth.

Do not use steam cleaners to clean the inside; the procedures and products recommended for the outside should be used.

Never wash removable wooden parts in the dishwasher; use only warm water and washing-up liquid or water and vinegar. Take care not to wet the electrical lighting components with water or detergents.

Clean the seals with warm water and then dry.

Take care not to block the defrosting water drainage hole with cleaning residues (foam or soap). Keep it unobstructed and clean it periodically with a toothpick.

To allow the appliance to operate at full efficiency, periodically also clean the outside of its rear with a cloth, to prevent excessive dust and dirt from collecting and interfering with its operation.

### 9.3 Switching off the wine cellar

If the wine cellar is to be out of use for some time, press the  button on the control panel. Then empty the cellar, disconnect it from the electrical mains, and once it has defrosted dry any residual moisture which has collected. Leave the door ajar to prevent the humidity and trapped air from creating unpleasant smells.

*The appliance should not be left unattended for more than 3-4 days. If you are to be away for some time, it is best to switch the wine cellar off.*





### 9.4 Operating noises

The wine cellar is cooled by means of a compression system. In order to maintain the preset temperature inside the wine cellar, the compressor comes into operation in response to the level of cooling required, and may operate continuously if necessary. When the compressor starts up a humming sound will be heard, tending to drop in volume after a few minutes. Other normal wine cellar operating noises are a gurgling and a rustling due to the refrigerant flowing through the pipes in the circuit. These noises are perfectly normal and do not mean that the appliance is malfunctioning. If they are over-loud, there may be other causes. In this case, check that:

- The wine cellar is properly levelled on the floor and does not vibrate when the compressor is in operation: **adjust the feet provided as appropriate;**
- the shelves are correctly fitted and securely in place: **fit correctly;**
- **the bottles on the various shelves are stable and not touching:** the vibration due to operation of the compressor may generate some noise;
- do not place **kitchen units or other appliances so that they are touching the wine cellar**



### 9.5 Identifying and Dealing with Malfunctions.

Your new wine cellar has been designed and built to strict quality standards. This section is intended to enable you to identify the origin of any malfunctions which may occur before contacting your local authorised After-Sales Service.

PROBLEM	POSSIBLE CAUSE	PROBABLE SOLUTION
Noisy operation		- see point "9.4 Operating noises"
The compressor starts up too often or operates continuously:	<ul style="list-style-type: none"> <li>- compressor and condenser cooling inadequate:</li> <li>- rise in outside temperature;</li> <li>- door opened often or for long periods;</li> </ul>	<ul style="list-style-type: none"> <li>- check that the rear of the appliance is properly ventilated as explained in point "4. installation and connection" and that the condenser is not over-dirty;</li> <li>- try not to open the door too often.</li> </ul>
The compressor does not start up:	<ul style="list-style-type: none"> <li>- Switch turned off;</li> <li>- power supply lead not connected to the electrical mains;</li> <li>- mains socket not supplying electrical power;</li> <li>- Room temperature too high.</li> </ul>	<ul style="list-style-type: none"> <li>- Press button ;</li> <li>- connect the cable to the power supply;</li> <li>- contact the utility company</li> </ul>
Cooling inside the wine cellar insufficient:	<ul style="list-style-type: none"> <li>- Inside temperature set too high (meaning reduced cooling effect).</li> <li>- door opened often or for long periods.</li> </ul>	<ul style="list-style-type: none"> <li>- Adjust the temperature using keys  or  as described in point "7.3 Temperature setting";</li> <li>- open the door less often and for as short a time as possible</li> </ul>
Too much condensation forming inside the wine cellar:	<ul style="list-style-type: none"> <li>- check that the door gaskets are providing an airtight seal on the wine cellar;</li> <li>- door opened often or for long periods;</li> </ul>	<ul style="list-style-type: none"> <li>- In case of cracks, try to soften the gasket by pulling it with one hand and sliding your closed fingers along the inside;</li> <li>- open the door less often and for shorter times, especially when the appliance is working in warm, humid conditions;</li> </ul>
Water in bottom of wine cellar:	<ul style="list-style-type: none"> <li>- "Condensation drain" opening blocked</li> </ul>	<ul style="list-style-type: none"> <li>- Clear the drain opening</li> </ul>
Door hard to open just after closing:		<ul style="list-style-type: none"> <li>- if you attempt to open a door again just after closing it, considerable strength is required. This is because of the vacuum caused by cooling of the warm air that has entered the appliance.</li> </ul>





## Instructions for the User

GB-IE

### AFTER-SALES SERVICE - READING THE NAMEPLATE.

IF THE PROBLEMS WITH THE PRODUCT YOU HAVE PURCHASED ARE NOT AMONGST THOSE DESCRIBED ABOVE AND IF YOU NEED MORE INFORMATION, PLEASE CONTACT THE AUTHORISED AFTER-SALES SERVICE. YOU WILL FIND THE ADDRESS AND TELEPHONE NUMBER IN YOUR LOCAL TELEPHONE DIRECTORY.

WHEN CONTACTING THE AFTER-SALES SERVICE, PLEASE BE READY TO INFORM OUR CALL SERVICE OPERATORS CLEARLY OF THE MODEL OF THE PRODUCT YOU HAVE PURCHASED AND THE SERIAL NUMBER MARKED ON THE NAMEPLATE INSIDE THE BODY OF THE WINE CELLAR.

		SERIAL N.
MODEL		
Type... SCV115		Serial No....20061602735
GROSS VOLUME REFRIG. 414 l NET VOLUME REFRIG. 368 l		
220-240 V ~ 50 Hz 1.5 A 350 W Temperature Class. SN-ST		
<hr/>		
REFRIG. R600A 0.065 KG		
Polyurethane foam with Cyclopentane Refrigerating circuit with R 600a		
VKG 861	104384	
o-X861.005-A1030466		



## 10. SOME HINTS FOR SAVING MONEY

The following is some simple, practical advice which will allow you to run your wine cellar to best effect, with peak performance and lower power consumption:

- 1 **Place** the wine cellar in the coolest part of the kitchen, well away from the cooker, radiators and the window, to protect it from variations in temperature.
- 2 **The correct distance from the wall** is at least 5 centimetres. This leaves enough room around the wine cellar for effective ventilation, necessary to prevent overheating and high power consumption.
- 3 **Never place bottles** touching the sides of the wine cellar.
- 4 **Do not place bottles inside the wine cellar** when they are still hot. This would tend to cause ice to form on the sides.
- 5 **The coldest area** is at the bottom; arrange wines depending on the temperature required.
- 6 Only open the door for the time strictly necessary for removing or inserting bottles, especially in hot weather. Opening the door often and for long periods causes the temperature inside the wine cellar to rise. This might cause the wines' quality to deteriorate and also increase the appliance's power consumption, as it has to reduce the temperature back to the set level.
- 7 **After disconnecting the power supply**, make sure that the condenser and the coil on the back of the appliance are clean. The layer of dust which forms disperses the low temperature and considerably increases power consumption.
- 8 If the wine cellar is to be out of use for a long period, it is best to empty it and switch it off.