

# PARTS LIST LISTA DE PIEZAS



## PORT-A-CUT IV

### MODELS:

PAC IV-51E    PAC IV-53E    PAC IV-75E    PAC IV-8KM  
PAC IV-9W    PAC IV-10Y    PAC IV-11R    PAC IV-13H  
PAC IV-13.5R    PAC IV-14KC    PAC IV-14KCR    PAC IV-14KM  
PAC IV-16KM    PAC IV-16BV    PAC IV-18BV    PAC IV-18H  
PAC IV-20H (Engine Mounted Fuel Tank)  
PAC IV-20H (Cowl Mounted Fuel Tank)

This Document Supersedes ONLY The "Parts List" Section of Document P/N 0A7669 "PAV IV Operating Instruction & Parts List".

Continue Usage Of P/N 0A7669 "Operating Instructions & Parts List" As "Operating Instructions" For 8KM, 9W, 10Y, 11R, 16BV, 18BV Models.

Este documento reemplaza SOLAMENTE a la "Lista de Piezas" del documento P/N 0A7669 "Instrucciones de Operación y Lista de Piezas del PAV IV".

Continúa el uso de P/N 0A7669 "Instrucciones de Operación y Lista de Piezas" como "Instrucciones de Operación" para los modelos 8KM, 9W, 10Y, 11R, 16BV, 18BV.

# TARGET

17400 West 119th Street  
Olathe, Kansas 66061  
Customer Service..... 800-288-5040  
Corp. Office..... 913-928-1000  
Cust. Service FAX..... 800-825-0028  
Corp. Office FAX..... 913-438-7951  
Customer Service, Int'l..... 913-928-1258  
Int'l. FAX..... 913-438-7938  
Internet..... <http://www.targetblue.com>

**Target Latin America, Mexico,  
Caribbean, Central & South  
America**

17400 West 119th Street  
Olathe, Kansas 66061  
Phone..... 913-928-1255  
Fax..... 913-438-7938

# PARTS LIST INDEX



For quick supply of spare parts and to avoid any lost time, it is essential to quote the data on the manufacturer's plate fixed to the machine and the part description to be replaced with every order.

<b>Model Designation Key</b>			
<b>Model</b>	<b>POWER SOURCE</b>	<b>Model</b>	<b>POWER SOURCE</b>
PACIV-51E	5 HP Baldor Electric (1 Phase)	PACIV-14KC	14 HP Kohler Command (Electric)
PACIV-53E	5 HP Baldor Electric (3 Phase)	PACIV-14KCR	14 HP Kohler Command (Recoil)
PACIV-75E	7-1/2 HP Baldor Electric (3 Phase)	PACIV-14KM *	14 HP Kohler Magnum
PACIV-8KM *	8 HP Kohler Magnum	PACIV-16KM	16 HP Kohler Magnum
PACIV-9W *	9 HP Wisconsin	PACIV-16BV *	16 HP Briggs & Stratton
PACIV-10Y **	10 HP Yanmar Diesel	PACIV-18BV *	18 HP Briggs & Stratton
PACIV-11R *	11 HP Robin	PACIV-18H *	18 HP Honda
PACIV-13H	13 HP Honda	PACIV-20H	20 HP Honda
PACIV-13.5R	13.5 HP Robin		

\* **Model Out Of Production – Shown For Service Parts Only**  
 \*\* **10Y Model Available Only Upon Special Request**

<b>DESCRIPTION</b>	<b>PAGE</b>
Warnings .....	4 - 5
Figures & Parts Lists & Wiring Diagrams:	
1. Frame Group.....	6 - 9
2. Engine & Blade Shaft Group .....	10 - 15
3. Drivematic Group .....	16 – 18
4. Fuel Tank Group – 20H.....	19
5. Accessories.....	20 - 21
6. Wide Cutting Kits (3/4" & 1" Wide) (Special Option).....	22 - 24
7. Electrical Components (7-1/2 Electric Model Only).....	25
8. Wiring Diagram: 75E.....	26
9. Wiring Diagram: 51E.....	27
10. Wiring Diagram: 53E.....	27
11. Wiring Diagram: 8KM.....	28
12. Wiring Diagram: 9W.....	28
13. Wiring Diagram: 10Y.....	29
14. Wiring Diagram: 11R.....	29
15. Wiring Diagram: 13H.....	30
16. Wiring Diagram: 14KM.....	30
17. Wiring Diagram: 14KC .....	31
18. Wiring Diagram: 14KCR.....	32
19. Wiring Diagram: 16KM.....	33
20. Wiring Diagram: 16BV / 18BV.....	34
21. Wiring Diagram: 18H & 20H.....	35
22. Wiring Diagram: 20H (Red Stripe Wire Harness) .....	36
23. Wiring Diagram: 20H (Blue Stripe Wire Harness).....	37
Decal Descriptions and Locations .....	38 - 40
Engine Mounting Locations & Base Attaching Points.....	41
Option Availability Chart - Per Model.....	43 - 45
Repair and Spare Parts .....	45
Additional Warnings .....	Back Cover

## INDICE DE LA LISTA DE PIEZAS



Para una rápida provisión de las piezas de repuesto y para evitar cualquier pérdida de tiempo, con cada orden de compra es esencial mencionar los datos de la placa del fabricante fijada a la máquina y la descripción de la pieza a ser reemplazada.

<b>Clave de Designación de Modelos</b>			
<b>Modelo</b>	<b>FUENTE DE ENERGIA</b>	<b>Modelo</b>	<b>FUENTE DE ENERGIA</b>
PACIV-51E	5 HP, Baldor Eléctrico (1 Fase)	PACIV-14KC	14 HP, Kohler Command (Electric)
PACIV-53E	5 HP, Baldor Eléctrico (3 Fases)	PACIV-14KCR	14 HP, Kohler Command (Recoil)
PACIV-75E	7-1/2 HP, Baldor Eléctrico (3 Fases)	PACIV-14KM *	14 HP, Kohler Magnum
PACIV-8KM *	8 HP, Kohler Magnum	PACIV-16KM	16 HP, Kohler Magnum
PACIV-9W *	9 HP, Wisconsin	PACIV-16BV *	16 HP, Briggs & Stratton
PACIV-10Y **	10 HP, Yanmar Diesel	PACIV-18BV *	18 HP, Briggs & Stratton
PACIV-11R *	11 HP, Robin	PACIV-18H *	18 HP, Honda
PACIV-13H	13 HP, Honda	PACIV-20H	20 HP, Honda
PACIV-13.5R	13.5 HP Robin		

\* Modelo fuera de producción – Se muestra para piezas de repuesto solamente  
 \*\* Modelo 10Y disponible como pedido especial solamente

<b>DESCRIPCION</b>	<b>PAGINA</b>
Advertencias.....	4 – 5
Listas de Ilustraciones y Piezas y Diagramas de Cableado:	
1. Grupo de Marco .....	6 - 9
2. Grupo del Motor y Eje de la Hoja.....	10 - 15
3. Transmisión Automática .....	16 – 18
4. Grupo de tanque de combustible – 20H .....	19
5. Accesorios .....	20 - 21
6. Equipos para Corte Ancho (3/4" y 1" de Ancho) (Opción Especial) .....	22 - 24
7. Componentes Eléctricos (Modelo Eléctrico 7-1/2 Solamente) .....	25
8. Diagrama de Cableado: 75E.....	26
9. Diagrama de Cableado: 51E.....	27
10. Diagrama de Cableado: 53E.....	27
11. Diagrama de Cableado: 8KM.....	28
12. Diagrama de Cableado: 9W .....	28
13. Diagrama de Cableado: 10Y.....	29
14. Diagrama de Cableado: 11R .....	29
15. Diagrama de Cableado: 13H .....	30
16. Diagrama de Cableado: 14KM.....	30
17. Diagrama de Cableado: 14KC .....	31
18. Diagrama de Cableado: 14KCR .....	32
19. Diagrama de Cableado: 16KM.....	33
20. Diagrama de Cableado: 16BV / 18BV .....	34
21. Diagrama de Cableado: 18H / 20H.....	35
22. Diagrama de Cableado: 20H .....	36
23. Diagrama de Cableado: 20H .....	37
Descripciones y Localizaciones de Calcomanías .....	38 - 40
Localizaciones del Montaje del Motor y Puntos de Colocación de Bases .....	41
Tabla de Disponibilidad de Opciones - Por Modelo .....	43 - 45
Piezas de Repuesto y Reparación .....	45
Advertencias Adicionales .....	Cubierta Posterior

## SAFETY FIRST!!



**WARNING: FAILURE TO COMPLY WITH THESE WARNINGS  
AND INSTRUCTIONS COULD RESULT IN DEATH OR SERIOUS INJURY.**



Each machine is supplied with an operating instruction manual. Operators and maintenance people of this equipment must read and be familiar with the safety warnings in the operation manual. Failure to obey the warnings may result in serious injury or death. Follow instructions strictly to ensure long service in normal operation. If you do not have an operator's manual (P/N 0A7768), call TOLL FREE 1-800-288-5040.



Read the entire operator's manual before operating this machine. Understand all the warnings, instructions and controls. If you do not have an operator's manual (P/N 0A7768) call TOLL FREE 1-800-288-5040.



Always park the machine on a level surface with the engine "OFF" and the ignition switch set in the "OFF" position before performing any maintenance. Let the machine cool down! Disconnect battery!



The manufacturer accepts no responsibility caused by unsuitable use or modifications.



For repairs and service parts, contact you authorized DB/T dealer.



This saw was designed for certain applications only DO NOT modify this saw or use for any application other than for which it was designed. If you have any questions relative to its application, DO NOT use the saw until you have contacted Diamant Boart Inc. and we have advised you.

Dimas North America  
17400 West 119th Street  
Olathe, Kansas 66061  
Telephone: 1-800-288-5040

# ¡SEGURIDAD ANTE TODO!

## ADVERTENCIAS

**ADVERTENCIA: EL NO RESPETAR ESTAS ADVERTENCIAS E INSTRUCCIONES DE OPERACION PUEDE PROVOCAR GRAVES LESIONES O LA MUERTE.**



Cada máquina se suministra con un manual de instrucciones de operación. Los operadores y los mecánicos de este equipo deben leer y familiarizarse con las advertencias de seguridad dadas en este manual. El no respetar las advertencias puede provocar graves lesiones o la muerte. Siga las instrucciones al pie de la letra para asegurar una larga vida de servicio durante operación normal. Si no tiene un manual del operador (N/P 0A7768), llame a su concesionario Target más cercano. Si se necesitan ejemplares adicionales, llamar SIN CARGO al 1-800-288-5040.



Lea todo este manual y familiarícese con el funcionamiento de la máquina antes de ponerla en marcha. Entienda todas las advertencias, instrucciones y controles. Si no tiene un manual del operador (N/P 0A7768), llame a su concesionario Target más cercano. Si se necesitan ejemplares adicionales, llamar SIN CARGO al 1-800-288-5040.



Siempre estacione la máquina en una superficie plana con el motor APAGADO y el interruptor de encendido puesto en la posición APAGADO (OFF) antes de hacer trabajos de mantenimiento en la máquina. ¡Deje que la máquina se enfríe! ¡Desconecte la batería! El fabricante no se hace responsable del uso o modificaciones indebidas!



El fabricante no se hace responsable del uso o modificaciones indebidas!



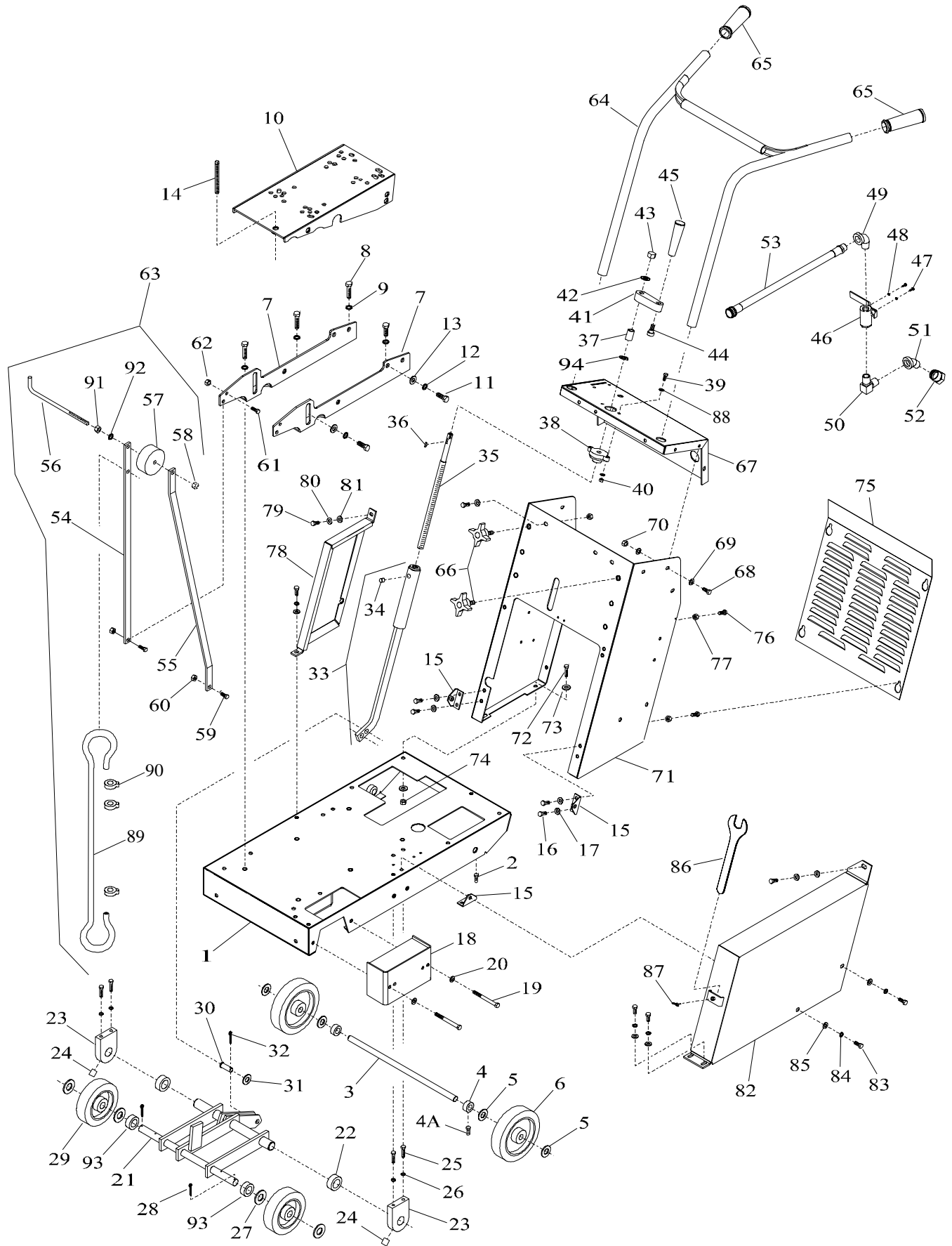
Para reparaciones y piezas de repuesto, póngase en contacto con el concesionario DB/T autorizado.



Esta sierra fue diseñada para ciertas aplicaciones solamente. NO la modifique ni utilice para ninguna otra aplicación salvo aquéllas para las cuales fue diseñada. En caso de dudas respecto a su aplicación, NO use la sierra sin antes haber consultado por escrito a Diamant Boart, Inc. y haber recibido nuestras indicaciones.

Diamant Boart, Inc.  
17400 West 119th Street  
Olathe, Kansas 66061  
1-800-288-5040

**FIGURE 1 – Frame Group / Grupo de Marco**



**FIGURE 1 – Parts List (Items 1 - 62)** (See Notes for Items Marked With “C” or “D”)

(REV 12-11-03)

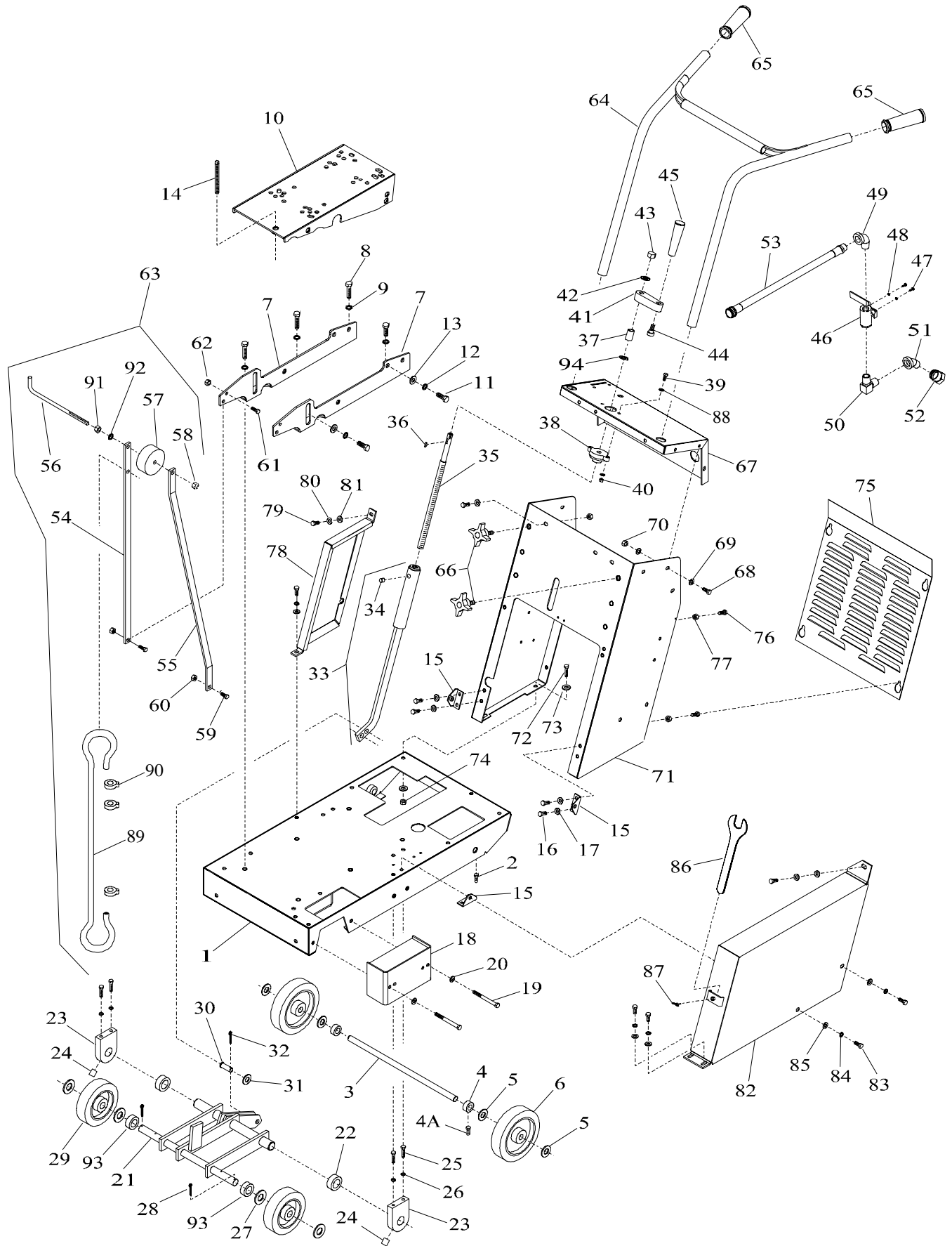
Diag Loc.	Part No.	Qty Req	Description (* Denotes Metric Item)	Diag Loc.	Part No.	Qty Req	Description (* Denotes Metric Item)
*1	167835	1	Frame Weldment (Metric)	36	020010	1	Key, Woodruff (ANSI #405)
2	020551	2	Setscrew, Socket Hd., 5/16"-18 x 1/4"	37	167878	1	Spacer, Zinc Plated
3	139579	1	Axle, Rear	38	542190434	1	Bearing, 1/2" Bore
4	049923	2	Collar, Lock, 5/8" Bore	*39	139761	2	Capscrew, Hex Hd., M6 x 1.0 x 20mm
4A	020551	2	Setscrew, Socket Hd., 5/16"-18 x 1/4"	*40	139745	2	Locknut, Fiber, M6 x 1.0
5	020747	4	Washer, Flat, 5/8" USS	41	-----	--	<b>Use Item 41C or 41D (See Note C or D)</b>
6	040126	2	Wheel, 6" OD, 5/8" Bore	41C	139024	1	Crank, Handle (Not Available-Use Item ??)
*7	167833	2	Support, Engine Base (Metric)	41D	177922	1	Crank, Handle
*8	139749	6	Capscrew, Hex Hd., M10 x 1.5 x 25mm	42	020788	1	Lockwasher, Split, 1/2"
*9	162004	6	Lockwasher, Split, M10	43	030210	1	Nut, Acorn, 1/2"-13 UNC
*10	167831	1	Base, Engine (Metric)	44	-----	--	<b>Use Item 44C or 44D (See Note C or D)</b>
*11	139741	4	Capscrew, Hex Hd., M12 x 1.75 x 30mm	44C	139022	1	Bolt, Shoulder, 1/2" DIA, 3/8"-16 UNC
12	020788	4	Lockwasher, Split, 1/2"	44D	-----	--	-----
13	020745	4	Washer, Flat, 1/2"	45	-----	--	<b>Use Item 45C or 45D (See Note C or D)</b>
*14	167439	1	Capscrew, Hex Hd, M12 x 1.75 x 100mm	45C	139100	1	Handle, Plastic, 3/8"-16 UNC
*15	167819	3	Bracket, Guard Mounting (Metric)	45D	032242	1	Handle, Aluminum, Revolving (Press Fit)
*16	197227	6	Capscrew, Hex Hd., M8 x 1.25 x 20mm	46	139021	1	Valve, Water
*17	020785	6	Lockwasher, Split, M8	47	020405	2	Screw, Round Hd, Phillips, #10-24 x 3/8"
18	167837	1	Shaft Guard Weldment	48	020782	2	Lockwasher, Split, #10
*19	177067	2	Capscrew, Hex Hd., M8 x 1.25 x 85mm	49	-----	--	<b>Use Item 49C or 49D (See Note C or D)</b>
*20	020785	2	Lockwasher, Split, M8	49C	020810	1	Fitting, 90 Street Elbow, 1/2" NPT
21	167775	1	Front Axle Weldment	49D	-----	--	-----
22	043260	2	Collar, 1" Bore	50	-----	--	<b>Use Item 50C or 50D (See Note C or D)</b>
*23	167781	2	Pivot Block (Metric)	50C	167897	1	Fitting, 90 Male Elbow, 1/2" NPT
24	041175	2	Grease Fitting	50D	-----	--	-----
*25	139749	4	Capscrew, Hex Hd., M10 x 1.5 x 25mm	51	-----	--	<b>Use Item 51C or 51D (See Note C or D)</b>
*26	162004	4	Lockwasher, Split, M10	51C	167960	1	Fitting, 45 Street Elbow, 1/2" NPT
27	020768	4	Washer, Flat, 3/4" SAE	51D	-----	--	-----
28	020614	2	Cotter Pin, 1/8" Dia x 1" Long	52	045642	1	Hose Fitting & Filter Washer
29	040091	2	Wheel, 5" DIA	53	-----	--	<b>Use Item 53C or 53D (See Note C or D)</b>
30	160164	1	Pin, Yoke	53C	167892	1	Hose Assy, 1/2" ID x 40" Long
31	020766	1	Washer, Flat, 1/2" SAE	53D	176177	1	Hose Assy, 1/2" ID x 49" Long
32	177239	1	Pin, Rue Ring, 1/2" DIA	54	167906	1	Bar, Pointer, Straight
33	-----	--	<b>Use Item 33C or 33D (See Note C or D)</b>	55	167908	1	Bar, Pointer, Offset
33C	177026	1	Adjustment Nut w/ Fitting, 5/8-11UNC	56	041231	1	Rod, Pointer, 3/8"-16 UNC
33D	177954	1	Adjustment Nut w/ Fitting, 5/8-8 ACME	57	041220	1	Wheel, 3" Dia, w/Bushing
34	-----	--	<b>Use Item 34C or 34D (See Note C or D)</b>	58	020199	1	Locknut, Fiber, 3/8"-16 UNC
34C	040139	1	Grease Fitting	*59	139749	2	Capscrew, Hex Hd., M10 x 1.5 x 25mm
34D	163140	1	Grease Fitting (2-5/8" Long)	*60	139748	2	Locknut Fiber, M10 x 1.5
35	-----	--	<b>Use Item 35C or 35D (See Note C or D)</b>	*61	197227	1	Capscrew, Hex Hd., M8 x 1.25 x 20mm
35C	167789	1	Screw, Adjustment, 5/8-11UNC	*62	139738	1	Locknut, Fiber, M8 x 1.25
35D	177915	1	Screw, Adjustment, 5/8-8 ACME				

**Notes:**

**C) These Items (Marked with a C) Effective from First Unit Production (S/N 167250) To Approx. February, 2000.**

**D) These Items (Marked with a D) Effective Spring (Approx. February) 2000.**

**FIGURE 1 – Frame Group / Grupo de Marco**





**FIGURE 1 – Parts List (Items 63 - 99)** (See Notes for Items Marked With “C” or “D”)

(REV 12-2-99)

Diag Loc.	Part No.	Qty Req	Description (* Denotes Metric Item)	Diag Loc.	Part No.	Qty Req	Description (* Denotes Metric Item)
63	177025	1	Front Pointer Assy (# 54-59 & #89-92)	88	020762	2	Washer, Flat, 1/4" SAE
64	167911	1	Handle Bar Weldment	89	172137	1	Rope, 5/32" x 80" Long (Nylon)
65	139568	2	Grip, Handle Bar	90	162761	3	Clamp, Hose
66	177557	2	Knob, Handle, 3/8"-16 UNC	91	020136	1	Nut, Std. Hex, 3/8"-16
				92	020786	1	Lockwasher, Split, 3/8"
67	-----	--	<b>Use Item 67C or 67D (See Note C or D)</b>				
67C	167800	1	Control Panel Weldment, PC Blue	93	041160	2	Collar, Lock, 3/4" Bore
67D	177909	1	Control Panel Weldment, PC Black	94	020766	1	Washer, Flat, 1/2" SAE
*68	197227	9	Capscrew, Hex Hd., M8 x 1.25 x 20mm	95	-----	--	<b>Use Item 95C or 95D (See Note C or D)</b>
69	020763	9	Washer, Flat, 5/16" SAE	95C	-----	--	-----
*70	139738	9	Locknut, Fiber, M8 x 1.25	95D	177923	1	Latch, Crank Handle, Zinc Plated
*71	177930	1	Cowl Weldment, PC Blue (Metric)				
*72	139749	4	Capscrew, Hex Hd., M10 x 1.5 x 25mm	96	-----	--	<b>Use Item 96C or 96D (See Note C or D)</b>
				96C	-----	--	-----
*73	173014	4	Washer, Flat, M10	96D	171710	1	Washer, Wave Spring, .28 ID
*74	139748	4	Locknut, Fiber, M10 x 1.5				
75	167807	1	Cover, Rear Cowl, PC Black (See Note "E")	97	-----	--	<b>Use Item 97C or 97D (See Note C or D)</b>
*76	167925	4	Capscrew, Flange Hd., M8 x 1.25 x 30mm	97C	-----	--	-----
*77	139738	4	Locknut, Fiber, M8 x 1.25	97D	161531	1	Washer, Fiber, .75x.265x.093" Thick
78	167814	1	Shield, RH (See Note "E")	98	-----	--	<b>Use Item 98C or 98D (See Note C or D)</b>
*79	197227	3	Capscrew, Hex Hd., M8 x 1.25 x 20mm	98C	-----	--	-----
80	020785	3	Lockwasher, Split, 5/16"	98D	139761	1	Capscrew, Hex Hd., M6 x 1.00 x 20mm
81	020763	3	Washer, Flat, 5/16" SAE				
				99	-----	--	<b>Use Item 99C or 99D (See Note C or D)</b>
82	167825	1	Belt Guard (Standard)	99C	-----	--	-----
—	167969	1	Belt Guard (Tall) (5E,7.5E,14KM, 18-20H)	99D	139745	1	Locknut, Fiber, M6 x 1.00
—	177002	1	Belt Guard (10Y Only)				
—	177595	1	Belt Guard (14KCR)				
*83	197227	5	Capscrew, Hex Hd., M8 x 1.25 x 20mm				
*84	020785	5	Lockwasher, Split, M8				
85	020763	5	Washer, Flat, 5/16" SAE				
86	163988	1	Wrench, 1-1/16" Open End				
*87	197170	1	Wing Bolt, M6 x 1.0 x 16mm				

**Notes:**

**C) These Items (Marked with a C) Effective from First Unit Production (S/N 167250) To Approx. February, 2000).**

**D) These Items (Marked with a D) Effective Spring (Approx. February, 2000).**

**E) These Items Used Only On Drivematic Equipped Models Effective Spring (Approx. February) 2000. Eliminated from Push Models – can be purchased separately for Push models Effective Spring 2000.**



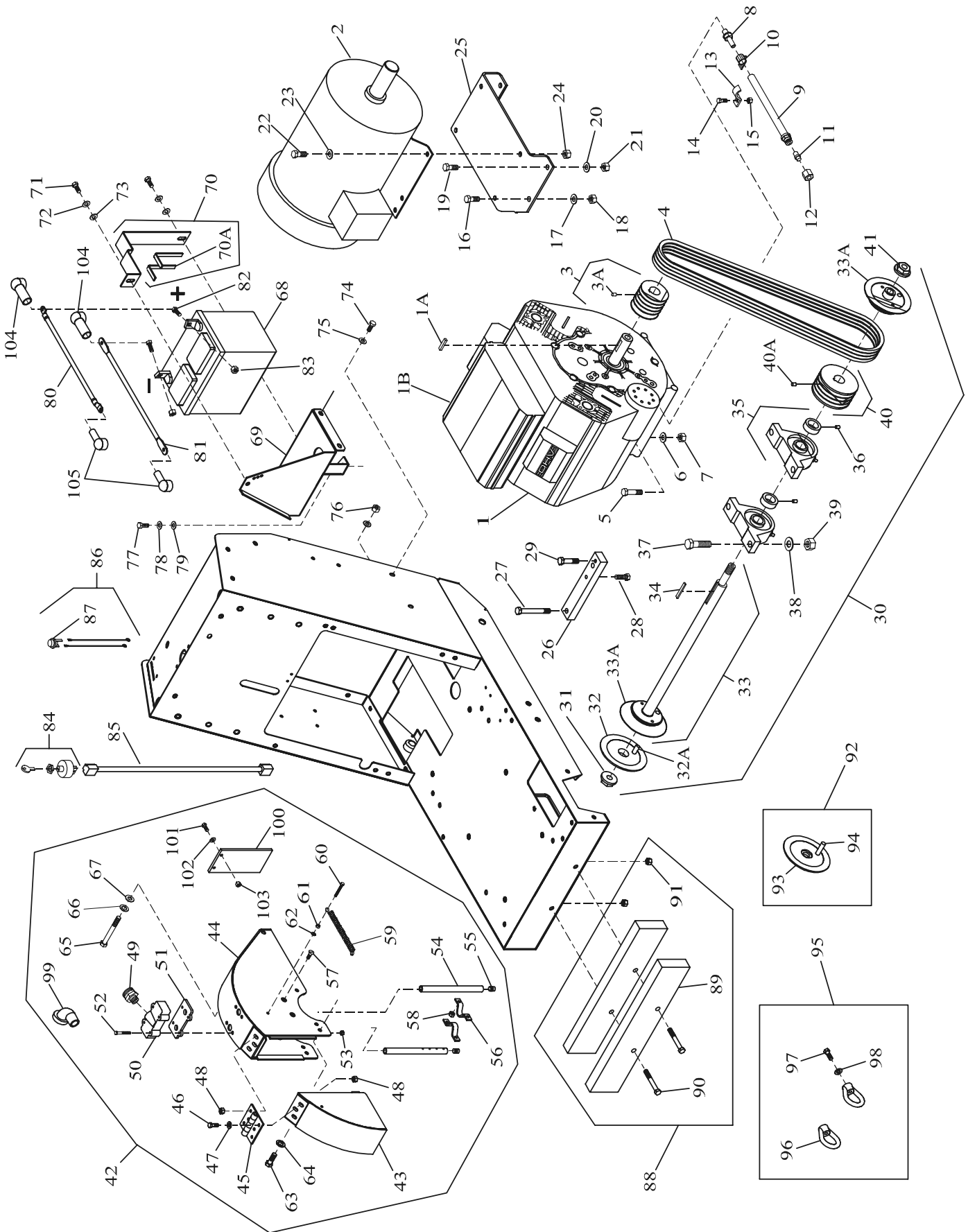
**FIGURE 2 - Parts List (Items 1 – 12)**

(REV 11-25-02)

DIAG LOC.	PART NO.	QTY REQ	DESCRIPTION (* Denotes Metric Item)	DIAG LOC.	PART NO.	QTY REQ	DESCRIPTION (* Denotes Metric Item)
1	139214	1	Engine, 8KM	4	161499	2	V-Belt, 3VX355 (51E, 53E)
—	011401	1	Engine, 9W	—	163857	3	V-Belt, 3VX425 (75E)
—	177015	1	Engine, 10Y (Diesel)	—	163869	3	V-Belt, 3VX375 (10Y)
—	177118	1	Engine, 11R	—	161499	3	V-Belt, 3VX355 (8KM, 11R, 13H, 13.5R, 14KC)
—	167821	1	Engine, 13H	—	163857	3	V-Belt, 3VX425 (14KCR)
—	196010	1	Engine, 13.5R	—	172281	3	V-Belt, 3VX400 (9W, 14KM)
—	167861	1	Engine, 14KC (Electric Start Only)	—	163869	4	V-Belt, 3VX375 (16KM, 18H, 20H)
—	177607	1	Engine, 14KCR (Recoil Start Only)	—	161499	4	V-Belt, 3VX355 (16BV, 18BV)
—	167996	1	Engine, 14KM				
—	139250	1	Engine, 16KM				
—	139697	1	Engine, 16BV				
—	167981	1	Engine, 18BV	*5	139765	4	Capscrew, Hex., M10x1.5x40mm (10Y, 13.5R, 16KM)
—	177282	1	Engine, 18H (No Longer Available)				
—	177461	1	Engine, 20H (See Note J)	*—	167748	4	Capscrew, Hex Hd., M10x1.5x65mm (18H, 20H)
—	190334	1	Engine, 20H, Modified (See Note J)	*—	139766	4	Capscrew, Hex Hd, M10x1.5x45mm (11R, 13H)
—	<b>190092</b>	<b>1</b>	<b>Engine, 20H (See Note J)</b>	*—	047792	4	Capscrew, Hex Hd, M10 x 1.5 x 30 mm (8KM)
				*—	167749	4	Capscrew, Hex Hd, M10 x 1.5 x 90 mm (9W)
1A	020067	1	Key, 1/4" Sq. x 1-1/4"	—	020323	4	Capscrew, Hex Hd., 3/8-16UNC x 1" (Full Thread) (14KC, 14KCR)
—	020078	1	Key, 1/4" Sq. x 3/4" (14KM, 16KM)				
—	177608	1	Key, Bevel, 1/4" Sq. x 2-5/8" (14KCR)	*—	173058	4	Capscrew, Hex Hd., M8x1.25x45mm (16BV, 18BV)
1B	-----	1	Element, Air Cleaner (See Note "A")	6	173014	4	Washer, Flat, M10 (8KM, 9W, 10Y, 11R, 13H, 13.5R, 16KM, 20H)
—	177528	1	Element, Air Cleaner (18H, 20H)	—	020743	4	Washer, Flat, 3/8" (14KC)
				*—	020742	4	Washer, Flat, 5/16" (16BV, 18BV)
				*7	139748	4	Locknut, Fiber, M10 x 1.5 (8KM, 9W, 10Y, 11R, 13H, 13.5R, 16KM, 18H, 20H)
2	177014	1	Motor, Electric (51E)	—	020786	4	Lockwasher, Split, 3/8" (14KC, 14KCR)
—	000923	1	Motor, Electric (53E)	*—	020199	2	Locknut, Fiber, 3/8"-16 (14KM)
—	167994	1	Motor, Electric (75E)				
3	167746	1	Pulley, 3G3V2.65, 1GRL-1.00 w/SS (8KM, 10Y, 11R, 13H, 13.5R)	*8	167133	1	Fitting, M12 x 10mm Barb (13H)
—	139298	1	Pulley, 3G3V3.15 - 1.125 w/SS (9W)	*—	177065	1	Fitting Assy, M14 x 3/8" Barb (11R, 13.5R)
—	139288	1	Pulley, 3G3V2.65-1.125-w/SS (14KM, 14KC, 14KCR)	—	020819	1	Fitting, 3/8" NPT x 3/8" Barb (9W, 14KC, 14KCR, 16BV, 18BV)
—	167942	1	Pulley, 4G3V2.65 - 1.125 w/SS (16KM, 20H) (See Note J)	—	177017	1	Fitting, 1/2" NPT x 3/8" Barb (8KM)
—	167889	1	Pulley, 4G3V2.65-1.00 w/SS (16BV, 18BV, 18H, 20H) (See Note J)	—	177018	1	Fitting, 3/4" NPT x 3/8" Barb (14KM, 16KM)
—	060139	1	Pulley, 2G3V2.65 - .875 w/SS (5E)	—	--	1	Fitting, Oil Drain (18H, 20H) (Honda # 15558-ZJ1-010AH)
—	041134	1	Pulley, 3G3V2.80 - 1.375 w/SS (75E)	—	177019	1	Fitting Assy, M16 x 1.5 x 3/8" Barb (10Y)
3A	020550	2	Setscrew, Soc. Hd, 5/16-18 x 3/8" (5E, 7.5E)	*9	167305	1	Hose Assembly, Oil Drain (All except noted)
—	020540	2	Setscrew, Soc. Hd, 1/4-20 x 1/4" (13-20 HP)	—	020967	1	Hose, Oil Drain (12") (18H, 20H Only)
—	020541	2	Setscrew, Soc. Hd, 1/4-20 x 3/8" (9 W)	—	167304	1	Hose Assembly, Oil Drain (14KCR)
				10	020049	1	Hose Clamp
				*11	167307	1	Blanking Cap
				*12	167623	1	Tube Nut, M16

See Notes on Page 15

**FIGURE 2 – Engine & Blade Shaft Group / Grupo del Motor y Eje de la Hoja (Continued)**



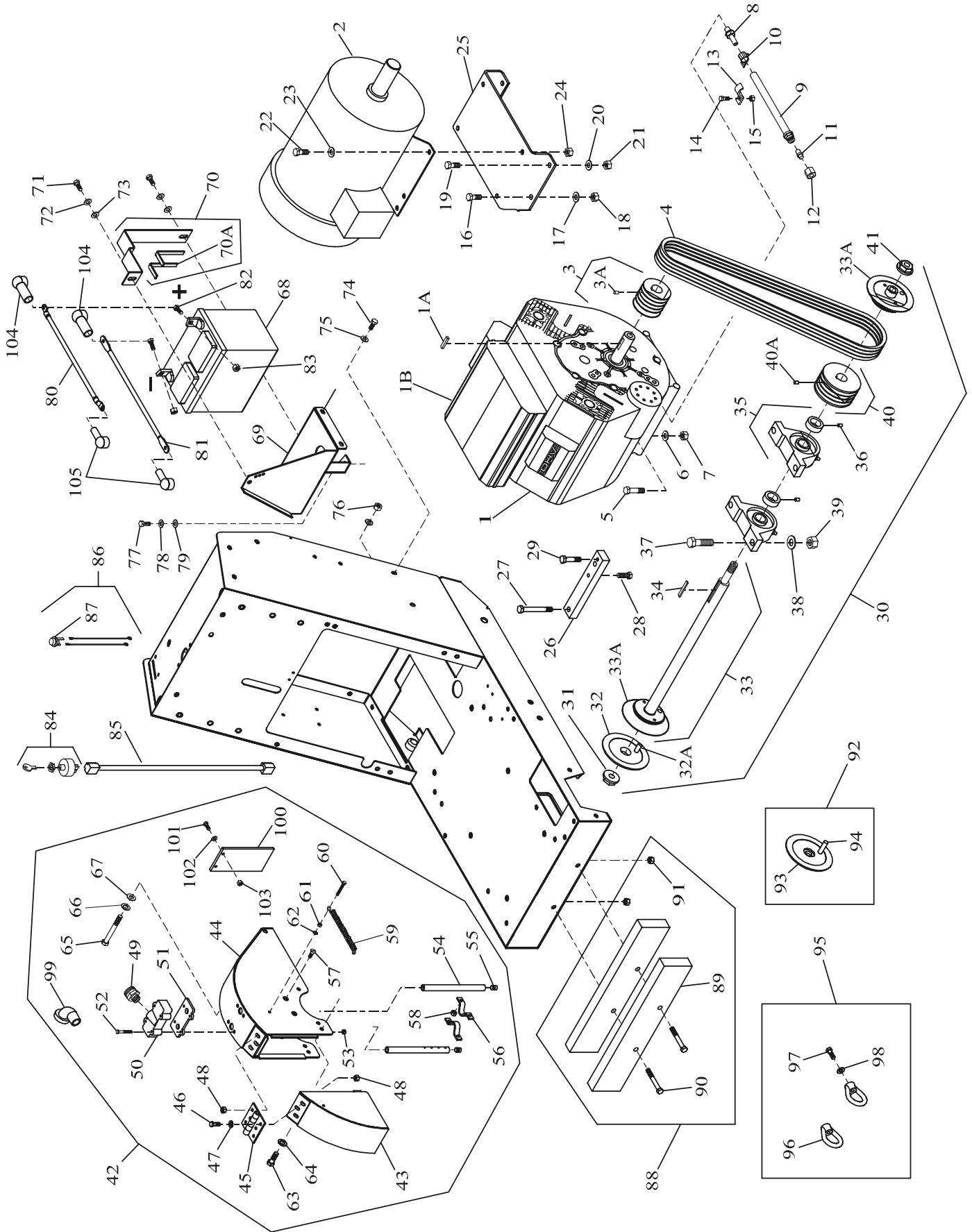
**FIGURE 2- Parts List (Items 13 - 72)**

(REV 7-11-02)

DIAG LOC.	PART NO.	QTY REQ	DESCRIPTION (* Denotes Metric Item)	DIAG LOC.	PART NO.	QTY REQ	DESCRIPTION (* Denotes Metric Item)
13	164238	1	Clamp (Used On 1994 Models Only)	*42	167943	1	Blade Guard Assy - 14" (Complete)
—	166673	1	Clamp, Insulated, 5/8" I.D. x 1/4" Hole (14kcr)	*—	195130	1	Blade Guard Assy - 18" (Complete)
				*—	195141	1	Blade Guard Assy - 20" (Complete)
*14	139761	1	Capscrew, Hex Hd., M6 x 1.0 x 20mm	43	139076	1	Front Blade Guard Weldment - 14"
—	163688	1	Capscrew, Hex Hd., M6 x 1.0 x 16mm (14kcr)	—	139596	1	Front Blade Guard Weldment - 18" (Note H)
*15	139745	1	Locknut, Fiber, M6 x 1.0	—	195120	1	Front Blade Guard Weldment - 18" (Note H)
				—	180846	1	Front Blade Guard Weldment - 20" (Note H)
*16	167478	1	Capscrew, Hex Hd., M8 x 1.25 x 25mm	—	195134	1	Front Blade Guard Weldment - 20" (Note H)
—	139749	4	Capscrew, Hex Hd., M10 x 1.5 x 25mm (14KCR)	44	----	--	Rear Blade Guard - Not Available Use Item 42
17	020763	2	Washer, Flat, 5/16" SAE				
—	173014	4	Washer, Flat, M10 (14KCR)	45	139075	1	Hinge (Note H)
				45A	195127	1	Hinge (Note H)
*18	139738	1	Locknut, Fiber, M8 x 1.25	*46	139761	6	Capscrew, Hex Hd, M6 x 1.0 x 20mm (Note H)
—	139748	4	Locknut, Fiber, M10 x 1.5 (14KCR)	*46A	167478	6	Capscrew, Hex Hd M8 x 1.25x25mm (Note H)
*19	139749	3	Capscrew, Hex Hd., M10 x 1.5 x 25mm	47	020762	6	Washer, Flat, 1/4" SAE (Note H)
*20	173014	3	Washer, Flat, M10	*47A	173059	6	Washer, Flat, M8 (Note H)
*21	139748	3	Locknut, Fiber, M10 x 1.5				
				*48	139745	6	Locknut, Fiber, M6 x 1.0 (Note H)
*22	139749	4	Capscrew, Hex Hd, M10 x 1.5 x 25mm (5E, 75E)	*48A	139748	7	Locknut, Fiber, M8 x 1.25 (Note H)
*23	173014	4	Washer, Flat, M10	49	040275	1	Fitting, 3/8" NPT Male x 3/4" Male
*24	139748	4	Locknut, Fiber, M10 x 1.5	50	139045	1	Manifold
25	167990	1	Motor Base (75E)				
—	177599	1	Engine Base (14KCR)	51	139051	1	Gasket, Manifold
				*52	167551	4	Capscrew, Hex Hd, M6 x 1.0 x 40mm
26	167992	2	Spacer, Engine (9W, 14KM, 18H, 20H)	*53	139745	4	Locknut, Fiber, M6 x 1.0
27	020365	2	Capscrew, Hex Hd., 3/8"-16 x 2-1/4"	54	167045	2	Water Tube -14"
28	020323	2	Capscrew, Hex Hd., 3/8-16 x 1"(Full Thread)	—	167046	2	Water Tube -18" & 20"
29	020377	2	Capscrew, Hex Hd., 3/8"-16 x 1-1/2"				
				55	020864	2	Plug, 1/8" NPT
30	167894	1	Blade Shaft-Complete-3 Groove (5 - 14 HP)	56	049212	2	Clamp, Water Tube
—	167893	1	Blade Shaft-Complete-4 Groove (16 - 20 HP)	*57	167818	4	Screw, Flat Hd., M6 x 1.0 x 16mm
31	167846	1	Nut, 5/8"-11UNC-LH Thread (Black Finish)	*58	139745	4	Locknut, Fiber, M6 x 1.0
32	167962	1	Outer Collar w/ Drive Pin	59	040330	1	Spring
32A	167964	1	Drive Pin, 3/8" Dia x 1-1/8" Long				
				*60	167761	2	Capscrew, Hex Hd, M5 x 0.8 x 20mm
33	167961	1	Blade Shaft w/ Inner Collars	*61	172011	4	Nut, Standard Hex M5 x 0.8
33A	167185	2	Inner Collar	62	020782	2	Lockwasher, Split, #10
34	020067	1	Key, 1/4" Sq. x 1-1/4"	*63	197227	1	Capscrew, Hex Hd M8 x 1.25 x 20mm
35	167895	2	Bearing w/Collar & SS (Eccentric Lock)	*64	020785	1	Lockwasher, Split, M8
				*65	167749	1	Capscrew, Hex Hd, M10 x 1.5 x 90mm
36	020540	2	Setscrew, Socket Hd., 1/4"-20 x 1/4"	*66	162004	1	Lockwasher, Split, M10
*37	139752	4	Capscrew, Hex Hd., M10 x 1.5 x 75mm	*67	173014	1	Washer, Flat, M10
*38	173014	4	Washer, Flat, M10	68	139255	1	Battery, 12V, 230 CCA - WET
*39	139748	4	Locknut, Fiber, M10 x 1.5	--	139255A	1	Battery, 12V, 230 CCA - DRY (Opt.)
40	139300	1	Pulley, 3G3V3.65-1" w/SS (5 - 14HP)	*69	167786	1	Battery Box Weldment
—	167896	1	Pulley, 4GR3V3.65-1" w/SS (16 - 20 HP)	70	167036	1	Strap, Battery Mount (Includes Item70A)
40A	020541	2	Setscrew, Soc. Hd., 1/4"-20x3/8" (For 139300)	70A	163248	1	Strip, Sponge Rubber (15 inches)
—	020541	4	Setscrew, Soc. Hd., 1/4"-20x3/8" (For 167896)	*71	197227	2	Capscrew, Hex Hd, M8 x 1.25 x 20mm
				72	020785	2	Lockwasher, Split, 5/16"
41	167847	1	Nut, 5/8"-11UNC-RH Thread (Gray Finish)				

See Notes on Page 15

**FIGURE 2 – Engine & Blade Shaft Group / Grupo del Motor y Eje de la Hoja (Continued)**



## FIGURE 2- Parts List (Items 73 - 105)

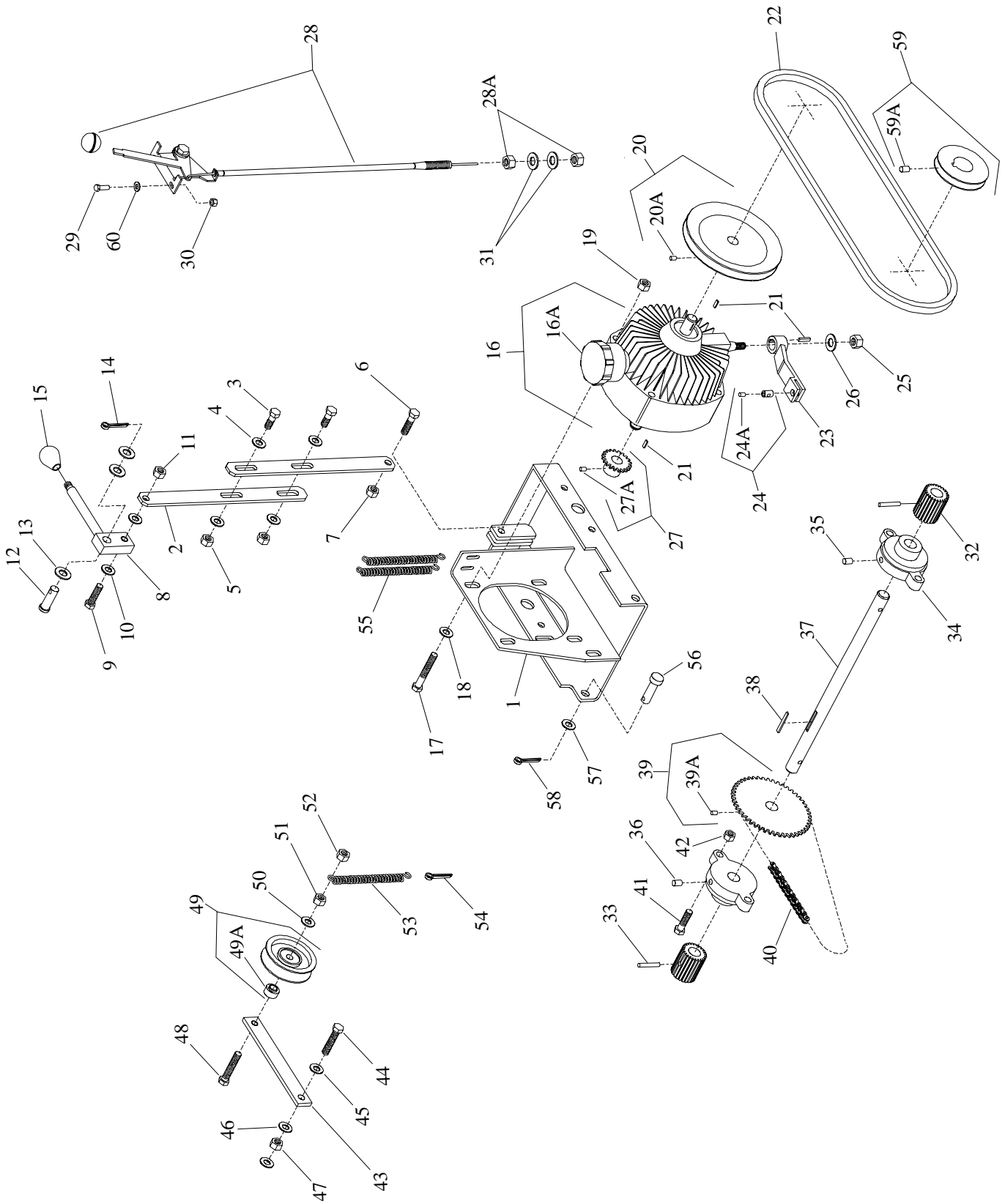
(REV 11-25-02)

DIAG LOC.	PART NO.	QTY REQ	DESCRIPTION (* Denotes Metric Item)	DIAG LOC.	PART NO.	QTY REQ	DESCRIPTION (* Denotes Metric Item)
73	020763	2	Washer, Flat, 5/16" SAE	88	167959	1	<b>Weight Kit (26 lbs.) (Optional)</b>
*74	197227	2	Capscrew, Hex Hd., M8 x 1.25 x 20mm	89	180418	4	Weight Bar-1/2" Thick (6-1/2 lbs. Each)
75	020763	2	Washer, Flat, 5/16" SAE	—	—	2	Weight Bar-1" Thick (13 lbs. Each)
*76	139738	2	Locknut, Fiber, M8 x 1.25	—	—	—	(1" Not Available Use 2 Of P/N 180418)
*77	197227	1	Capscrew, Hex Hd., M8 x 1.25 x 20mm	90	020329	2	Capscrew, Hex Hd., 3/8"-16 x 2-3/4"
				91	020199	2	Locknut, Fiber, 3/8"-16
78	020785	1	Lockwasher, Split, 5/16"				
79	020763	1	Washer, Flat, 5/16" SAE	92	167963	1	<b>Outer Collar Assy-1/2"Cut (Optional)</b>
80	177063	1	Battery Cable (+) (RED)	93	167865	1	Outer Collar, 4.50 OD x 1/2" Cut
—	542190395	1	Battery Cable (+) (RED)(14KC,18H,20H)	94	020304	1	Drive Pin, 3/8" x 1-1/2"
*81	167891	1	Battery Cable, (-) (BLACK)	95	167189	1	<b>Tiedown Bracket Kit (Optional)</b>
*82	163688	2	Capscrew, Hex Hd., M6 x 1.0 x 16mm	96	167125	2	Eye nut, Saw Tiedown, 3/8"-16UNC
*83	139745	2	Locknut, Fiber, M6 x 1.0	97	020323	2	Capscrew, Hex Hd., 3/8"-16 x 1"
				98	020786	2	Lockwasher, Split, 3/8"
84	167735	1	Ignition Switch w/ Key (16KM)				
—	163830	1	Ignition Switch w/Key (18H, 20H) (Notes C & F)	99	167985	1	Fitting, 45 Deg Street, 3/8" NPT (9W)
—	177920	1	Ignition Switch w/Key (18H, 20H) (Notes D & F)	100	139098	1	Flap, Splash
				*101	167761	2	Capscrew, Hex Hd., M5 x 0.8 x 20mm
85	139272	1	Wiring Harness (16KM)	*102	173047	2	Washer, Flat, M5
—	177283	1	Wiring Harness (18H, 20H) (See Notes C & G)	*103	172316	2	Locknut, Fiber, M5 x 0.8
—	177913	1	Wiring Harness (18H, 20H) (See Note D & G)				
—	542190390	1	Wiring Harness-20H (See Note K)	104	177066	2	Boot, Rubber – Battery
86	139156	1	Stop Switch Assembly (8KM)	105	177068	2	Boot, Rubber – Cable (14KC Only)
—	139196	1	Stop Switch Assembly (9W)	—	177066	1	Boot, Rubber – Cable (18H, 20H)
—	177021	1	Stop Switch Assembly (11R, 13H)				
—	196019	1	Stop Switch Assembly (13.5R)				
—	177022	1	Stop Switch Assembly (14KC)	—	167104	1	<b>Items Not Shown On Figure 2:</b> Guard, Muffler (Optional: 14KM, 16KM)
—	177612	1	Stop Switch Assembly (14KCR)				
—	177023	1	Stop Switch Assembly (14KM)	--	-----	1	Regulator (18H, 20H) (Honda P/N 31620-ZG5-003)
—	167727	1	Stop Switch Assembly (16BV, 18BV)	--	166890	2	Capscrew, Hex Hd, M6 x 1.0 x 30mm **
				--	020762	2	Washer, Flat, 1/4" SAE**
87	041317	1	Switch, Push-Button	--	139745	2	Locknut, Fiber, M6 x 1.0 **
							** Use To Attach Regulator (18H, 20H)

### Figure 2 Notes:

- A) See Engine Distributor For Item 1B (Element) For The Following Models: 8KM, 9W, 10Y, 11R, 13H, 13.5R, 14KM, 14KCR, 14KC, 16KM, 16BV, 18BV.
- C) These Items (Marked with a C) Effective from First Unit Production (S/N 167250) To Approx. February, 2000).
- D) These Items (Marked with a D) Effective Spring (Approx. February, 2000).
- F) Ignition Switch P/N 163830 must be used with P/N 177283 Wiring Harness. Ignition Switch P/N 177920 must be used with P/N 177913 Wiring Harness. When both items are serviced together it is suggested that the 177920 / 177913 part combination be used because the push-on wire connectors are easier to assemble.
- G) Wiring Harness P/N 177913 can be identified by the RED stripe near the "engine end" of the harness. P/N 177283 does not have a colored stripe.
- H) For Item 45A, P/N 195127 Hinge (1/4" Thick) use P/N 195120 Front Guard Weldment, 18" or P/N 195134 Front Guard Weldment, 20" and M8 attaching hardware (Items 46A, 47A & 48A). For Item 45, P/N 139075 Hinge (1/8" Thick) use P/N 139228 Front Guard Weldment, 18" or P/N 174672 Front Guard Weldment, 20" and M6 attaching hardware (Items 46, 47 & 48).
- J) Engine model changed for saws mfg. After 15November2002. P/N 177461 Engine has a 1.00" dia. Crankshaft and requires P/N 167889 pulley (1.00" I.D.). Effective about 15November2002 with saw serial number 383022; units mfg. using P/N 190334 Engine and requires P/N 167942 pulley (1.125" I.D.). P/N's 177461 & 190334 Engines (w/ Engine Mounted Fuel Tanks) Not Available as of April 2003. P/N 190092 Engine & Fuel Tank Group (See Figure 4) is the only replacement for a complete older style engine.
- K) Wiring Harness P/N 542190390 can be identified by a BLUE stripe at one end, & is used only with Engine P/N 190092.

FIGURE 3 - Drivematic Group / Transmisión Automática

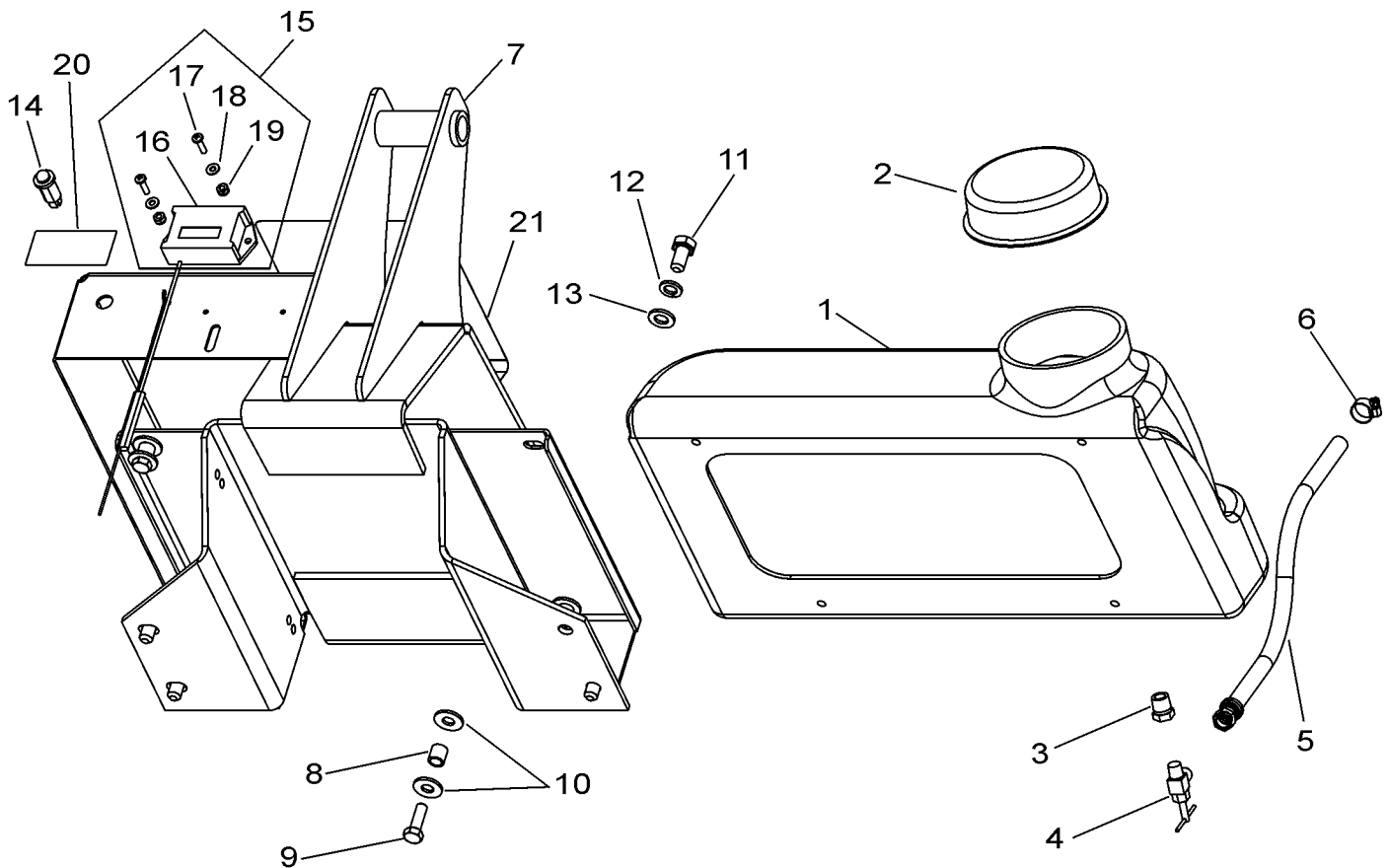




**FIGURE 3 – Parts List**

DIAG LOC.	PART NO.	QTY REQ	DESCRIPTION (* Denotes Metric Item)	DIAG LOC.	PART NO.	QTY REQ	DESCRIPTION (* Denotes Metric Item)
1	167876	1	Platform Weldment, Transmission	*29	139740	2	Capscrew, Hex Hd., M6 x 1.0 x 25mm
2	167882	2	Linkage	*30	139745	2	Locknut, Fiber, M6 x 1.0
*3	139749	2	Capscrew, Hex Hd., M10 x 1.5 x 25mm	31	020766	2	Washer, Flat, 1/2" SAE
*4	173014	4	Washer, Flat, M10	32	044181	2	Wheel, Drive
*5	139748	1	Locknut, Fiber, M10 x 1.5	33	020643	2	Roll Pin, 1/4 x 1-1/4"
*6	047792	1	Capscrew, Hex Hd., M10 x 1.5 x 30mm	34	044161	2	Bearing, Flange, 3/4" Bore
*7	139748	1	Locknut, Fiber, M10 x 1.5	35	164296	1	Fitting, Grease, 45 Deg, 1/4"-28 Thread
*8	167791	1	Lever, Transmission Engage (Metric)	36	041175	1	Fitting, Grease, 90 Deg, 1/4"-28 Thread
*9	167034	1	Capscrew, Hex Hd., M10 x 1.5 x 40mm Full Thread	37	167784	1	Shaft, Transmission Drive
*10	173014	2	Washer, Flat, M10	38	020062	1	Key, 3/16" Square x 1-1/4" Long
*11	139748	1	Locknut, Fiber, M10 x 1.5	39	041389	1	Sprocket-w/SS, #35,48Teeth,3/4" Bore
12	167843	1	Pin, Clevis, 1/2" x 1-1/2"	39A	020541	2	Setscrew, Soc Hd, 1/4-20 x 3/8" (Included w/ Item 39)
13	020766	3	Washer, Flat, 1/2"	40	139104	1	Chain, #35, 63 Pitches
14	167035	1	Pin, Cotter, Hair Spring (1/2" Pin)	41	048740	4	Capscrew, Hex Hd., 3/8"-16 x 1-1/4"
15	041427	1	Knob, Trans. Lever, 3/8-16UNC	42	020199	4	Locknut, Fiber, 3/8"-16
16	046131	1	Transmission (includes Item 16A)	43	167874	1	Arm, Idler
16A	048326	1	Oil Reservoir w/Cap and O-Ring	*44	177064	1	Capscrew, Hex Hd., M10 x 1.5 x 45mm Full Thread
*17	139752	4	Capscrew, Hex Hd., M10 x 1.5 x 75mm	*45	173014	7	Washer, Flat, M10
*18	173014	4	Washer, Flat, M10	*46	162004	1	Lockwasher, Split, M10
*19	139748	4	Locknut, Fiber, M10 x 1.5	*47	139750	1	Nut, Std. Hex, M10 x 1.5
20	041360	1	Pulley 1GA6.00 - .67 w/SS	*48	164968	1	Capscrew, Hex Hd., M10 x 1.5 x 50mm Full Thread
20A	020541	2	Setscrew, Soc Hd., 1/4-20UCN x 3/8"	49	167764	1	Pulley, 1G4L3.0-.375 w/ Bushing (Includes Item 49A)
21	020085	3	Key, Woodruff (ANSI #404)	49A	167762	1	Bushing, M10 & 3/8" Bore
22	167932	1	V-Belt, 4L410 (16KM)	*50	162004	1	Lockwasher, Split, M10
—	160938	1	V-Belt,4L420 (75E, 8KM, 9W, 14KC, 16BV, 18BV)	*51	139750	1	Nut, Std. Hex, M10 x 1.5
—	043750	1	V-Belt, 4L440 (10Y, 11R, 13H, 18H, 20H)	*52	139748	1	Locknut, Fiber, M10 x 1.5
—	048649	1	V-Belt, A-44 (14KCR)	53	139102	1	Spring
—	164369	1	V-Belt, A-41 (14KM)	54	020618	1	Pin, Cotter 3/16 Dia x 1" Long
23	167937	1	Lever Weldment, Control	55	139102	2	Spring
24	046179	1	Pin, Pivot w/Setscrew (Incl. Item 24A)	56	177000	2	Pin, Clevis, 1/2 Dia x 1" Long
24A	020547	1	Setscrew, Socket Hd., #10-24 x 1/4"	57	020766	8	Washer, Flat 1/2"
25	020199	1	Locknut, Fiber, 3/8"-16UNC	58	177239	2	Pin, Rue Ring, 1/2" Dia
*26	173014	1	Washer, Flat, M10	59	041301	1	Pulley 1GA2.75 - 1.125 w/SS (Includes # 59A) (9W, 14KM, 14KC)
27	041370	1	Sprocket, w/Setscrew, #35, 12 Teeth	59A	020551	2	Setscrew, Soc Hd, 5/16"-18 x 1/4" (9W, 14KM, 14KC)
27A	020540	2	Setscrew, Socket Hd., 1/4"-20 x 1/4" (Included w/ Item 27)	60	020762	2	Washer, Flat, 1/4"
28	167873	1	Cable Assembly, Trans. Speed Control (Includes Item 28A)				
28A	—	2	Nut, Jam, 7/16"-20UNF				

**FIGURE 4 – Fuel Tank Group (Cowl Mounted): 20 HP Honda (After April 2003)**  
**Grupo de tanque de combustible**



**FIGURE 4 – Parts List (See Notes Below)**

DIAG LOC.	PART NO.	QTY REQ	DESCRIPTION	DIAG LOC.	PART NO.	QTY REQ	DESCRIPTION
1	539300742	1	Fuel Tank, w/ Bushing (Note 2)	12	162004	4	Lockwasher, Split, M10
2	539106188	1	Cap, Fuel	13	173014	4	Washer, Flat, M10
3	542190393	1	Bushing, Hex, 1/8"NPT x 1/4"NPT (Male)	14	542190401	1	Light, Low Oil Indicator
4	542190392	1	Valve, Fuel, 1/8"NPT x 1/4" SAE	--	--	--	Optional Items:
5	191328	1	Fuel Line, 1/4"SAE x 15" Long	15	190249	1	Kit: Tach-Hourmeter (Note 3)
6	174740	1	Clamp, Worm Gear, SAE 006	16	190248	1	Tach-Hourmeter (Surface Mount)
7	542190396	1	Fuel Tank Bracket	17	197293	2	Screw, M4 x 16
8	539102845	4	Spring, Fuel Tank	18	197290	2	Washer, M4
9	021416	4	Capscrew, Hex Hd, .312-18UNC x 1"	19	167485	2	Locknut, Fiber, M4 x .70
10	020742	8	Washer, Flat, .312	20	542190402	1	Decal, Low Oil Indicator Light
11	139744	4	Capscrew, Hex Hd, M10 x 1.5 x 20mm	21	542190403	1	Tape, Heat Reflecting

**Notes:**

1. Items shown in this Figure are Only For Use With P/N 192092 Engine, 20H. Older models of the 20hp Honda Engine That Use The Engine Mounted Fuel Tank Are No Longer Available, As of April 2003.
2. Fuel Tank (P/N 539300742) Includes a Female 1/4" NPT Bulkhead Bushing (Not Shown On This Parts List).
3. Tach-Hourmeter Kit (P/N 190249) Includes Installation Instructions, & Items 15-19, & Additional Parts Used For Other Models. This Tach-Hourmeter Kit Can Also Be Installed On PACIV-13H (13 hp Honda Model), & Most Other Gasoline Powered PAC IV Models.

**Notes:**

---

---

---

---

---

---

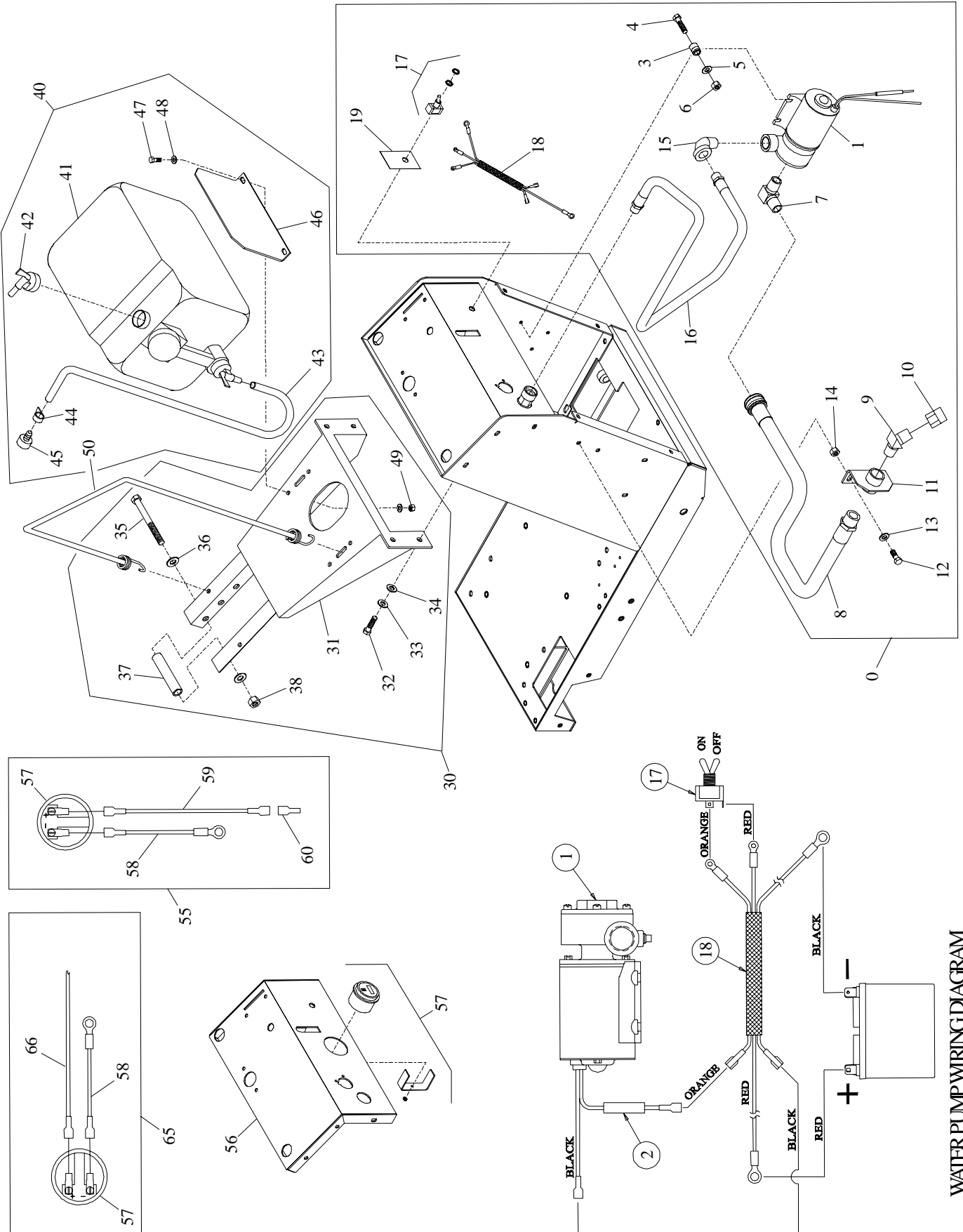
---

---

---

---

**FIGURE 5 – Accessories / Accesorios**



**FIGURE 5 – Parts List**

DIAG LOC.	PART NO.	QTY REQ	DESCRIPTION (* Denotes Metric Item)	DIAG LOC.	PART NO.	QTY REQ	DESCRIPTION (* Denotes Metric Item)
0	167965	1	Water Pump Kit				
1	177016	1	Water Pump	40	167966	1	Water Tank Kit
2	-----	1	Fuse – 10 Amp	41	139706	1	Tank, Water (5 Gallon)
3	-----	4	Spacer, Rubber (Included w/ Item 0)	42	177050	1	Spigot, Water Tank (VENT)
*4	166890	4	Capscrew, Hex Hd., M6 x 1.0 x 30mm	43	177060	1	Hose – 3/8" x 30"
5	020762	4	Washer, Flat, 1/4"	44	020049	1	Hose Clamp
*6	139745	4	Locknut, Fiber, M6 x 1.0	45	174020	1	Fitting, 3/4" FGH x 3/8" ID Hose
7	090306	1	Fitting, 3/4" NPT 90 Male Elbow	46	177047	1	Bracket, Water Tank
8	163770	1	Hose Assembly, Water-3/4" (Inlet)	*47	167478	2	Capscrew, Hex Hd, M8 x 1.25 x 25mm (Full Thread)
9	090308	1	Fitting, 3/4" NPT 45 Male Elbow				
10	045643	1	Hose Fitting & Washer	*48	173059	4	Washer, Flat, M8
11	163594	1	Water Pump Bracket	*49	139738	2	Locknut, Fiber, M8 x 1.25
*12	197227	2	Capscrew, Hex Hd., M8 x 1.25 x 20mm	50	167724	1	Tiedown, Elastic 28"
13	020742	2	Washer, Flat, 5/16"				
*14	139738	2	Locknut, Fiber, M8 x 1.25	55	-----	1	<b>Hour Meter Group – 16BV &amp; 18BV</b> (Includes items 56-60)
15	040273	1	Fitting, 3/4" NPT 90 Street Elbow				
16	163769	1	Hose Assy, Water-3/4" (Outlet)	56	177030		Control Panel – Modified (Blue)
17	052120	1	Toggle Switch, Water Pump On/Off	57	163779		Hour Meter w/Mounting Kit
18	167869	1	Wire Harness, Water Pump	58	177057		Wire Assy – Ground (-) (16KM,16BV,18BV)
19	167935	1	Decal, Water Pump On/Off	--	177285	1	Wire Assy – Ground (-) (18H & 20H)
30	177059	1	<b>Kit, Lift Bail (All Models – Except 20H)</b>	59	177058	1	Wire Assy – Positive (+) (16B, 18BV)
31	167857	1	Lift Bail	--	177286	1	Wire Assy – Positive (+) (18H & 20H)
*32	139744	4	Capscrew, Hex Hd., M10 x 1.5 x 20mm				
—	139749	2	Capscrew, Hex Hd., M10 x 1.5 x 25mm (139749 at Lower Holes–18H & 20H Only)	60	177056	1	Terminal, 1/4" Female
*33	162004	4	Lockwasher, Split, M10	65	-----	1	<b>Hour Meter Group – 16 KM</b> (Includes items 56-58, 66)
*34	173014	4	Washer, Flat, M10	--	-----	1	<b>Hour Meter Group – 18H &amp; 20H</b> (Includes Items 56-59)
*35	167532	1	Capscrew, Hex Hd., M12 x 1.75 x 140mm				
*36	173042	2	Washer, Flat, M12	66	177051	1	Wiring Harness – Modified (16KM)
37	177031	1	Spacer, Lift Bail				
*38	139742	1	Locknut, Fiber, M12 x 1.75				
39	020745	4	Washer, Flat, 1/2" USS  (Install between Item 31 & Cowl In Lower Holes Only– 18H & 20H Only)				

**See “Option Availability” Section Of This Document**

**For the Availability of Options & Accessories on each Model**



**WARNING:** Refer To The Operating Instructions And Applicable Instruction Sheets For The Proper Installation of Options & Accessories Before Beginning The Installation! Part Numbers For The Applicable Instruction Sheets Are Shown In The “Option Availability” Section Of This Document.

**Ver la Sección “Disponibilidad de Opciones” de Este Documento**

**Para Verificar la Disponibilidad de Opciones y Accesorios para cada Modelo**

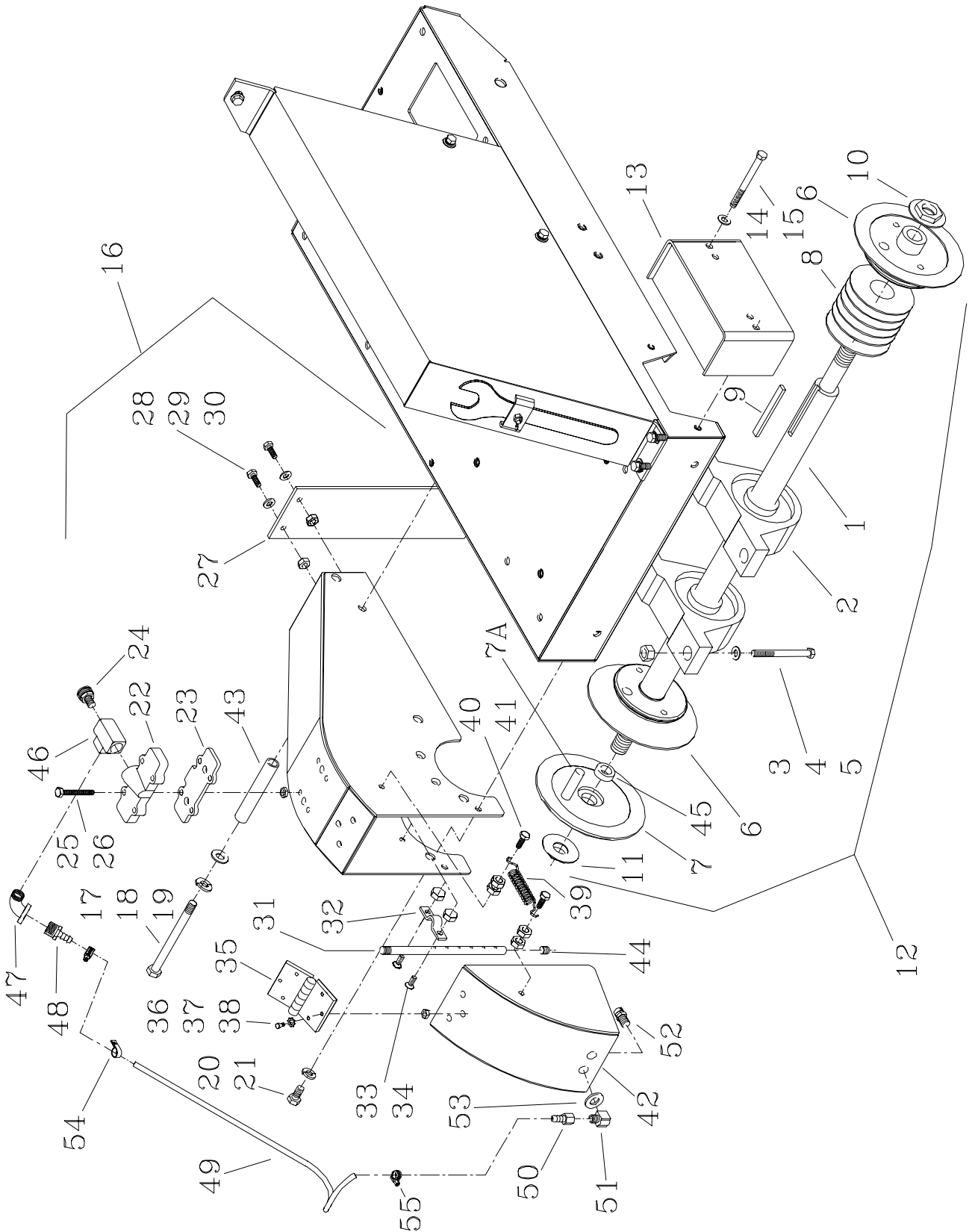


**ADVERTENCIA:** ¡Antes de comenzar la instalación, refiérase a las Instrucciones de Operación y a las Hojas de Instrucciones aplicables para realizar apropiadamente la instalación de opciones y accesorios! Los Números de Piezas para las Hojas de Instrucciones aplicables se muestran en la sección “Disponibilidad de Opciones” de este documento.

**Figure 6 – Wide Cutting Kits (Optional Or Accessory)**  
**Equipos para Corte Ancho (3/4" y 1" de Ancho) (Opción Especial)**

P/N 177535 Kit, Complete, 3/4" Wide

P/N 177542 Kit, Complete, 1" Wide



**Figure 6 – Parts List**

Item	Qty	Part No	Description (* Denotes Metric Item)	Item	Qty	Part No	Description (* Denotes Metric Item)
--	1	177535	Kit, Complete, 3/4" Wide Cut (Note 1)	24	1	040275	Adapter, 3/8 NPT-3/4" Garden Hose
--	1	177542	Kit, Complete, 1" Wide Cut (Note 2)	25	4	167551	Capscrew, Hex Hd., M6 x 1.0 x 40
--	--	-----	<b>Note 1:</b> 3/4" Kit Includes All Items	26	4	139745	Locknut, Fiber M6 x 1.0
--	--	-----	except Item 45 & 7A (P/N 163485)	27	1	163275	Guard, Splash
--	--	-----	<b>Note 2:</b> 1" Kit Includes Items 1-55	28	2	139761	Capscrew, Hex Hd., M6 x 1.0 x 20
1	1	177531	Shaft, Blade (3/4" & 1" Cutting)	29	2	139746	Washer, Flat M6
2	2	167895	Bearing, 1", Eccentric Lock	30	2	139745	Locknut, Fiber M6 x 1.0
3	4	139752	Capscrew, Hex Hd., M10 x 1.50 x 75 mm	31	2	161003	Water Tube w/ Plug
4	4	173014	Washer, Flat M10	32	2	049212	Clamp, Water Tube
5	4	139748	Locknut, Fiber M10 x 1.50	33	4	167818	Screw, Flat M6 x 1.0 x 16
6	1	177529	Collar, Inner	34	4	139745	Locknut, Fiber M6 x 1.0
7	1	167963	Collar, Outer w/ 1.50" Dowel Pin	35	1	049154	Hinge
7A	1	020304	Pin, Dowel .375 x 1.50 (.75" Cut)	36	6	167478	Capscrew, Hex Hd., M8 x 1.25 x 25
--	1	163485	Pin, Dowel .375 x 1.75 (1.0" Cut) **	37	6	173059	Washer, Flat M8
8	1	167896	Pulley, 4G3V3.65 w/ Setscrews	38	6	139738	Locknut, Fiber M8 x 1.25
9	1	020067	Key, 1/4" Sq. x 1-1/4"	39	1	043145	Spring
10	1	167847	Nut, Flange, 5/8-11UNC, RH thread	40	2	139761	Capscrew, Hex Hd., M6 x 1.0 x 25
11	1	167846	Nut, Flange, 5/8-11UNC, LH thread	41	4	172017	Nut, Hex M6 x 1.0
12	1	177536	Blade Shaft Assembly (Items 1-11)	42	1	177544	Front Guard Weldment Only
13	1	177533	Guard, Shaft (3/4" & 1" Cutting)	43	1	177537	Spacer, Guard
14	2	167553	Capscrew, Hex Hd., M8 x 1.25 x 100	44	2	020864	Plug, 1/8" Socket Head
15	2	020785	Lockwasher, Split M8	45	1	177541	Spacer, Arbor (1" Cutting Only)**
16	1	177538	Blade Guard Assembly (Items below)	46	1	15700939	Fitting, Street Tee, 3/8" NPT
17	1	176668	Capscrew, Hex Hd., M10 x 1.5 x 120	47	1	020815	Fitting, Street Elbow, 3/8" NPT
18	1	162004	Lockwasher, Split M10	48	1	177547	Fitting, 3/8" NPT x 1/4" Barb
19	1	173014	Washer, Flat M10	49	1	177548	Hose, 1/4" ID x 15" Long
20	1	197227	Capscrew, Hex Hd., M8 x 1.25 x 20	50	1	161133	Fitting, Female, 1/8" NPT x 1/4" Barb
21	1	020785	Lockwasher, Split M8	51	1	020811	Fitting, 90° Str. Elbow 1/8" NPT
22	1	049196	Manifold	52	1	048902	Nozzle, 30°
23	1	049206	Gasket, Manifold	53	1	020764	Washer, Flat 3/8" SAE
				54	1	166672	Clamp, 5/16 x 9/32" Hole
				55	2	020049	Clamp, Gear 7/32-5/8"



**WARNING:** Refer to Instruction Sheet 0A7767 for proper installation of the Wide Cutting Kits. Install the proper blade spacers (See Below) between each diamond blade so that the segments on the diamond blades DO NOT touch when the outer flange is tightened. Failure to follow this warning could result in injury or death to the operator or persons in the work area! **Special Note for 1" wide cutting:** Replace the 1-1/2" long dowel pin (Item 7A, P/N 020304) that is installed from the factory in the outer flange with the 1-3/4" long dowel pin (Item 7A, P/N 163485) included in the 1" wide cutting kit. If dowel pin does not go through ALL the blades and into inside flange then the maximum blade stacking capacity has been exceeded, and some blade(s) MUST be removed.

Blade Spacers (Not Included in this Kit)		
Part No.	Qty	Description
049500	As Required	Spacer, 5.0" Outside Dia x 1.00" Arbor x 16 Gauge (.060") Thick
049502	As Required	Spacer, 5.0" Outside Dia x 1.00" Arbor x 18 Gauge (.048") Thick
161800	As Required	Spacer, 8.0" Outside Dia x 1.00" Arbor x 4 Gauge (.224") Thick
161801	As Required	Spacer, 8.0" Outside Dia x 1.00" Arbor x 6 Gauge (.194") Thick
161802	As Required	Spacer, 8.0" Outside Dia x 1.00" Arbor x 8 Gauge (.164") Thick
161803	As Required	Spacer, 8.0" Outside Dia x 1.00" Arbor x 10 Gauge (.134") Thick
161804	As Required	Spacer, 8.0" Outside Dia x 1.00" Arbor x 14 Gauge (.075") Thick
161805	As Required	Spacer, 8.0" Outside Dia x 1.00" Arbor x 15 Gauge (.067") Thick
161806	As Required	Spacer, 8.0" Outside Dia x 1.00" Arbor x 18 Gauge (.048") Thick
161807	As Required	Spacer, 8.0" Outside Dia x 1.00" Arbor x 20 Gauge (.036") Thick



**ADVERTENCIA:** Refiérase a la Hoja de Instrucciones 0A7767 para efectuar la instalación apropiada de los Equipos para Corte Ancho. Instale los espaciadores apropiados (ver abajo) entre cada hoja diamantada, de manera que los segmentos de las hojas diamantadas NO se tocan cuando la brida externa es apretada. ¡El incumplimiento de esta advertencia podría producir lesiones o la muerte del operador o de las personas que se encuentran en el área de trabajo! **Nota Especial para cortes de 1" de ancho:** Reemplace la clavija de 1-1/2" de largo (Artículo 7A, P/N 020304), que es instalada en fábrica en la brida externa, con la clavija de 1-3/4" de largo (Artículo 7A, P/N 163485) que se incluye en el equipo para corte de 1" de ancho. Si la clavija no pasa a través de todas las hojas y dentro de la brida, quiere decir que se ha excedido la máxima capacidad de amontonamiento de hojas y que alguna(s) hoja(s) DEBE(N) ser sacada(s).

Espaciadores de Hojas (no se incluyen en este equipo)		
Pieza No.	Cantidad	Descripción
049500	La que sea necesaria	Espaciador, 5.0" de Diámetro Externo x 1.00" de Eje x Calibre 16 (.060") de Espesor
049502	La que sea necesaria	Espaciador, 5.0" de Diámetro Externo x 1.00" de Eje x Calibre 18 (.048") de Espesor
161800	La que sea necesaria	Espaciador, 8.0" de Diámetro Externo x 1.00" de Eje x Calibre 4 (.224") de Espesor
161801	La que sea necesaria	Espaciador, 8.0" de Diámetro Externo x 1.00" de Eje x Calibre 6 (.194") de Espesor
161802	La que sea necesaria	Espaciador, 8.0" de Diámetro Externo x 1.00" de Eje x Calibre 8 (.164") de Espesor
161803	La que sea necesaria	Espaciador, 8.0" de Diámetro Externo x 1.00" de Eje x Calibre 10 (.134") de Espesor
161804	La que sea necesaria	Espaciador, 8.0" de Diámetro Externo x 1.00" de Eje x Calibre 14 (.075") de Espesor
161805	La que sea necesaria	Espaciador, 8.0" de Diámetro Externo x 1.00" de Eje x Calibre 15 (.067") de Espesor
161806	La que sea necesaria	Espaciador, 8.0" de Diámetro Externo x 1.00" de Eje x Calibre 18 (.048") de Espesor
161807	La que sea necesaria	Espaciador, 8.0" de Diámetro Externo x 1.00" de Eje x Calibre 20 (.036") de Espesor



## FIGURE 7 - Electrical Components for 75E Model Only (7-1/2 HP Electric)

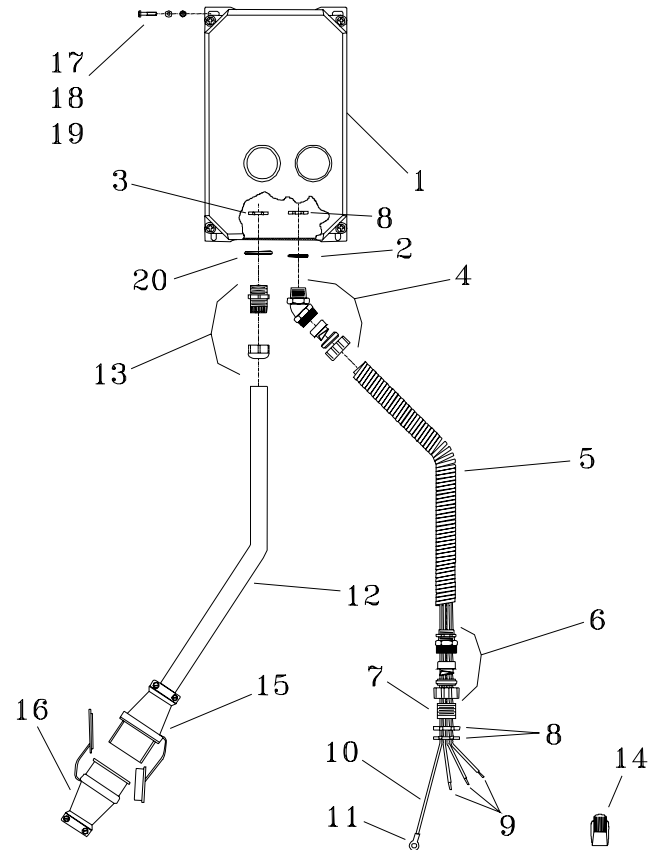
**Figure 7A** - Items included in Conversion Kits -

- A) P/N 177442 [convert 230V to 460V]
- B) P/N 177443 [convert 460V to 230V]

**Ilustración 7A** – Artículos incluidos en los Equipos Conversions

- A) P/N 177442 (convierte 230V a 460V)
- B) P/N 177443 (convierte 460V a 230V)

Item	Qty	Part No	Description
1	1	180068	Starter Box Assembly, 460V (A)
--	1	180069	Starter Box Assembly, 230V (B)
2	1	176932	Ring, Sealing, 1/2"
3	1	175244	Locknut, Conduit 1/2"
4	1	176937	Connector, Seal Tight 45°
5	1	176955	Conduit, 1/2" Flexible
6	1	176935	Connector, Seal Tight, Straight
7	1	182015	Reducer, 3/4 - 1/2"
8	3	176953	Locknut, Conduit 3/4"
9	3	182016	Wire, Black, 12 Ga. 53" Long
10	1	182017	Wire, Green, 12 Ga. 57" Long
11	1	182021	Terminal, Ring #10, 12-10 Ga.
12	1	182018	Cord, SOW, 12 Ga/4 Wire-27" Lg
13	1	182024	Strain Relief, Water Tight 3/4"
14	6	090556	Connector, Wire (A)
--	4	090556	Connector, Wire (B)
15	1	182010	Connector, Male 480V (A)
--	1	182012	Connector, Male 250V (B)
16	1	182009	Connector, Female 480V (A)
--	1	182011	Connector, Female 250V (B)
17	4	177460	Capscrew, Hex M4 x 0.7 x 30
18	4	167485	Locknut, Fiber M4 x 0.7
19	4	197290	Washer, Flat M4
20	1	176933	Ring, Sealing 3/4"

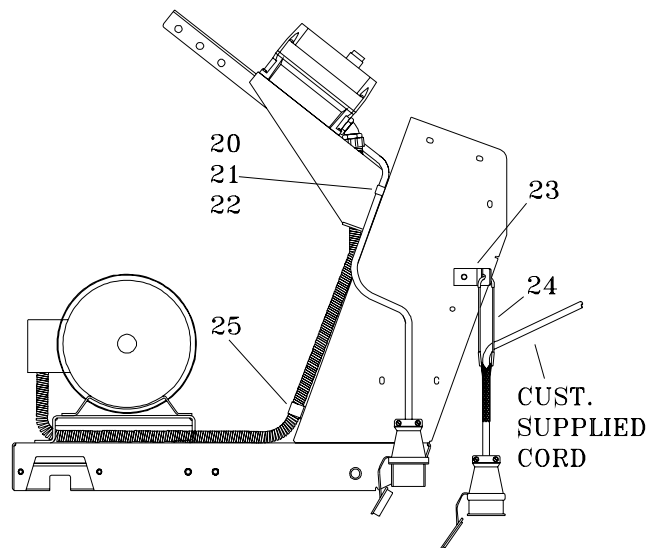


**FIGURE 7A**

**Figure 7B** - Factory built saws include all Items in Figure 6A and Figure 6B (below). Note that Item 24 holds an electrical cord that is connected to Item 16. **This cord MUST be supplied by the customer**

**Ilustración 7B** - Las sierras hechas en fábrica incluyen todos los artículos en la Ilustración 6A y en la Ilustración 6B (abajo). Note que el Artículo 24 sostiene un cable eléctrico que está conectado al Artículo 16. **Este cable DEBE ser proporcionado por el cliente.**

Item	Qty	Part No	Description
20	1	166676	Clamp, 5/8 x 3/8"
21	1	139749	Capscrew, Hex M10 x 1.5 x 25
22	1	173014	Washer, Flat M10
23	1	177457	Bracket, Strain Relief
24	1	177459	Cable Support, Bus Drop
25	1	166955	Clamp, 1 x 3/8"



**FIGURE 7B**

**FIGURE 8 - Wiring Diagram & Voltage Conversion-75E (7-1/2 HP, 3 Phase Electric)**

This Figure applies to all 230V and 460V 7.5 HP electric Models. Conversion kits are available to convert to and from 230V and 460V 3 phase units.

Kit P/N 177442 Convert 230V to 460V  
 Kit P/N 177443 Convert 460V to 230V

NOTICE: The end user is responsible for providing electrical service in accordance with the National Electric Code and any other applicable local codes. Service must at the minimum, motor disconnection means, motor branch-circuit short-circuit protection, motor branch-circuit ground-fault protection, and correctly sized motor circuit conductors.

Connect the green and black wires to the electric motor as shown below for your specific unit. If the electric motor rotates backwards after wiring the unit, switch any two black line wires to reverse the motor direction.

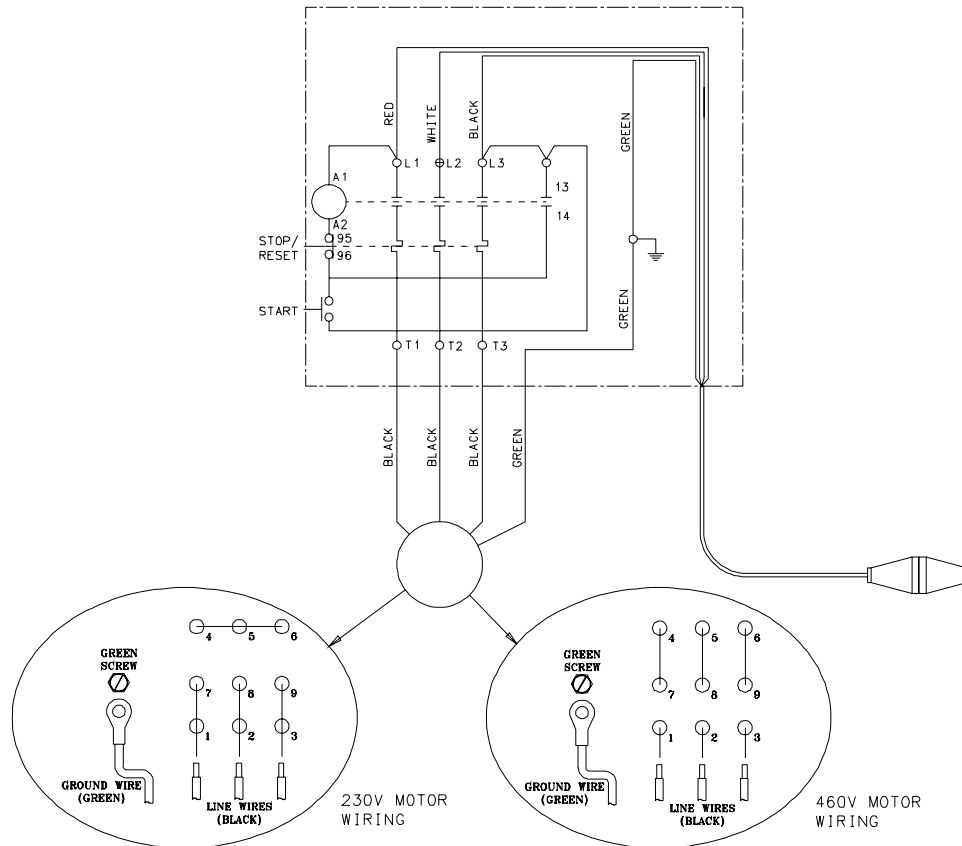
**ILUSTRACION 8 - Diagrama de Cableado y Conversión de Voltaje-75E (Eléctrico de 7-1/2 HP, 3 Fases)**

Esta ilustración se aplica a todos los modelos eléctricos de 230V y 460V de 7.5 HP. Existen disponibles equipos de conversión para convertir unidades de 3 fases a /y de 230V y 460V.

Equipo P/N 177442 Convierte 230V a 460V  
 Equipo P/N 177443 Convierte 460V a 230V

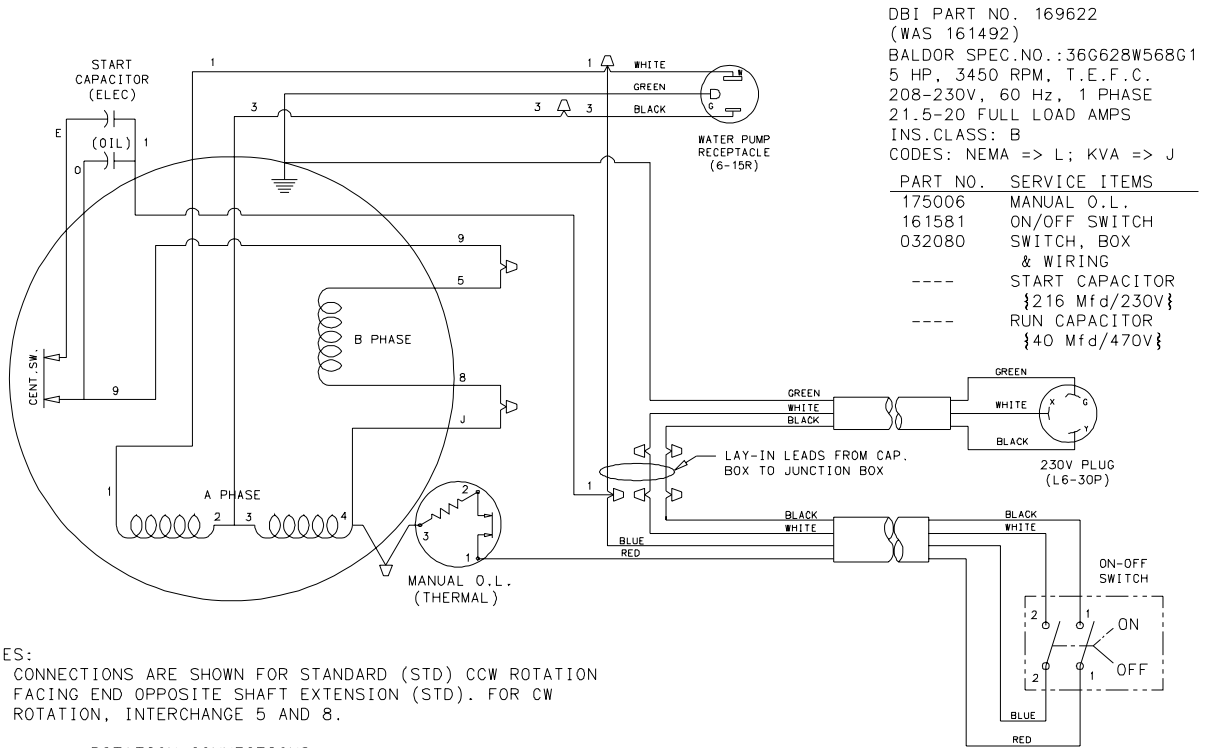
NOTIFICACION: El usuario final es responsable de suministrar la energía eléctrica de acuerdo con el Código Nacional de Electricidad y cualquier otro código local aplicable. Como mínimo, el servicio de energía eléctrica debe tener medios para desconectar el motor, protección contra cortocircuitos del circuito ramal del motor, protección contra fallas de la conexión a tierra del circuito ramal del motor y conductores del circuito del motor correctamente dimensionados.

Conecte los cables verde y negro al motor eléctrico, tal como se muestra abajo para su unidad específica. Si el motor eléctrico rota al revés después de cablear la unidad, cambie dos líneas negras cualesquiera para revertir la dirección del motor.



WIRING DIAGRAM - 75E MODELS (7-1/2 HP, 3 Phase Electric)

**FIGURE 9 – Wiring Diagram – 51E (5 HP, 208-230 Volts, 60 Hertz, 1 Phase Electric Motor)**  
 [Note: Same Electrical Schematic For P/N's 177014 & 169622 (Shown)]  
 (P/N 177014 is P/N 169622 with 1/2" Cut From Motor Shaft)

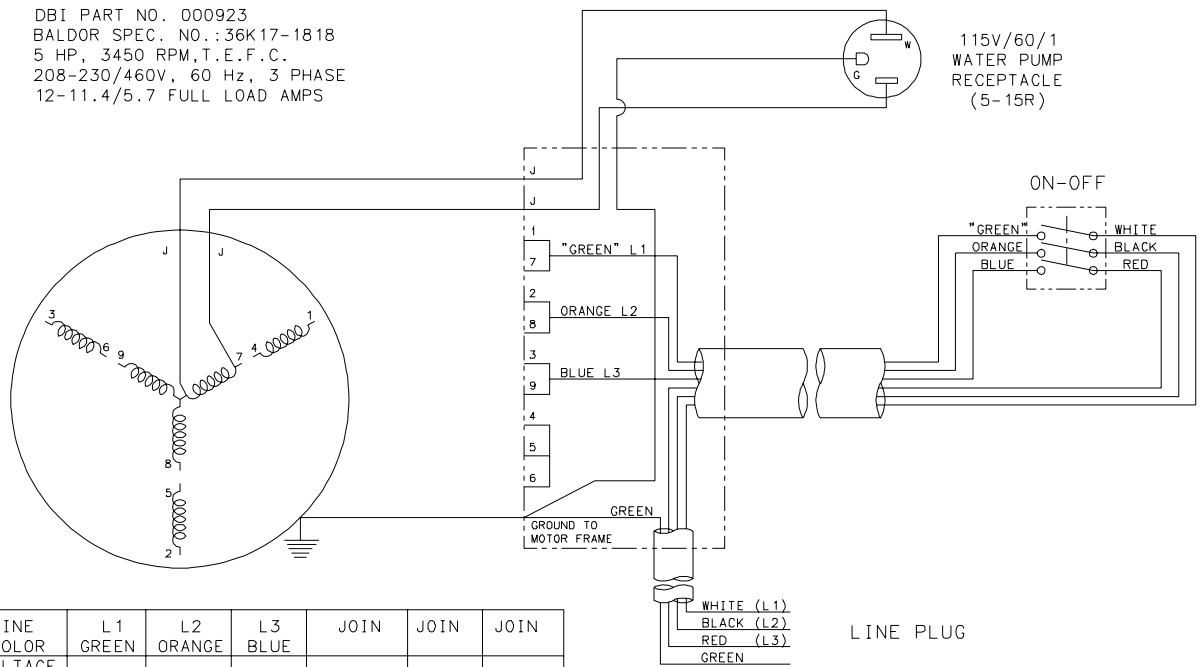


NOTES:  
 1. CONNECTIONS ARE SHOWN FOR STANDARD (STD) CCW ROTATION FACING END OPPOSITE SHAFT EXTENSION (STD). FOR CW ROTATION, INTERCHANGE 5 AND 8.

2. ROTATION CONNECTIONS

	JOIN	JOIN	ROT.	
STD.	9,8	J,5	CCW	
OPP.	9,5	J,8	CW	

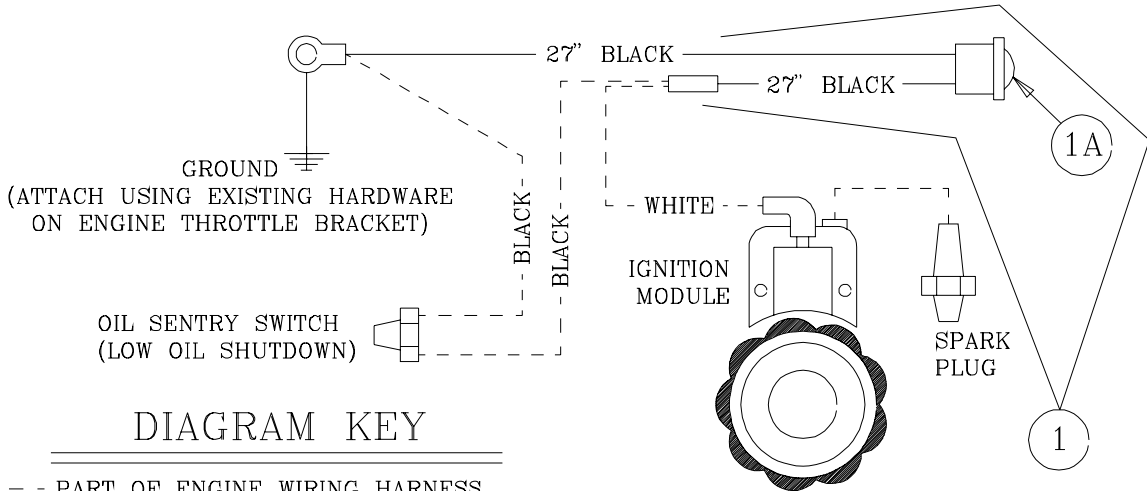
**FIGURE 10 – Wiring Diagram – 53E (5 HP, 208-230 / 460 Volts, 60 Hertz, 3 Phase Electric Motor)**



NOTE:  
 1. TO CHANGE ROTATION: REVERSE 2 LINE LEADS ON LINE PLUG.

**FIGURE 11 – Wiring Diagram - 8KM (8 HP Kohler Magnum)**

1A	1	041317	STOP SWITCH (INCLUDED IN ITEM 1)
1	1	139156	STOP SWITCH ASSY (WITH WIRES)(8KM)
ITEM	QTY	PART NO.	DESCRIPTION
BILL OF MATERIAL-8KM ENGINE			



**DIAGRAM KEY**

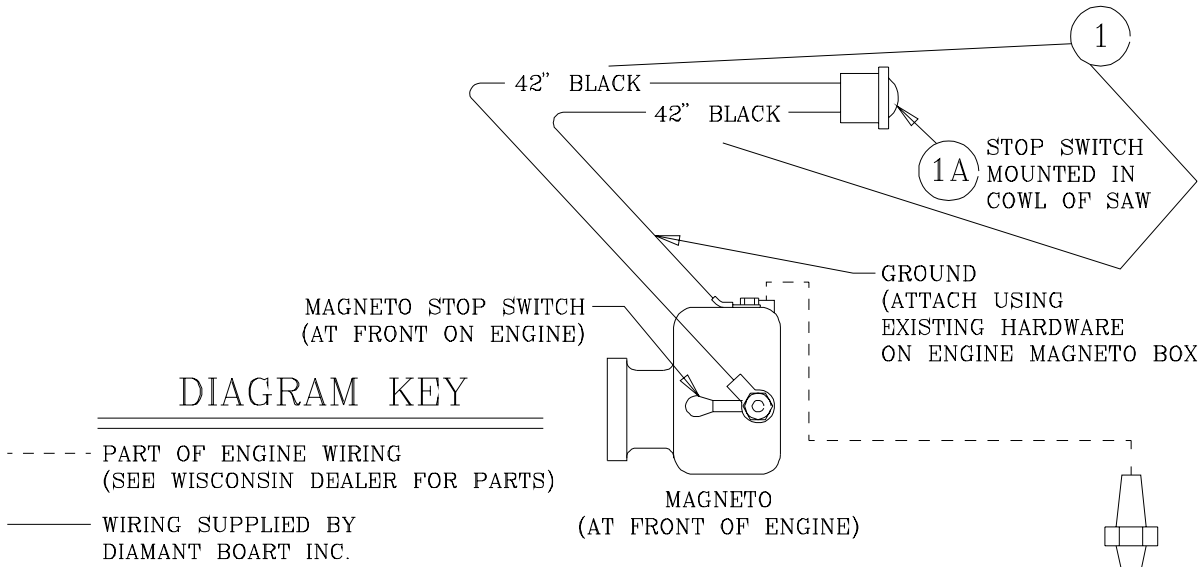
--- PART OF ENGINE WIRING HARNESS  
(SEE KOHLER DEALER FOR PARTS)

— WIRING SUPPLIED BY  
DIAMANT BOART INC.

8HP KOHLER MAGNUM  
(DB INC. P/N:139214 ENGINE-8KM)  
(KOHLER SPEC.#301554)

**FIGURE 12 – Wiring Diagram - 9W (9 HP Wisconsin)**

1A	1	041317	STOP SWITCH (INCLUDED IN ITEM 1)
1	1	139196	STOP SWITCH ASSY (WITH WIRES)(9W)
ITEM	QTY	PART NO.	DESCRIPTION
BILL OF MATERIAL-9W ENGINE			



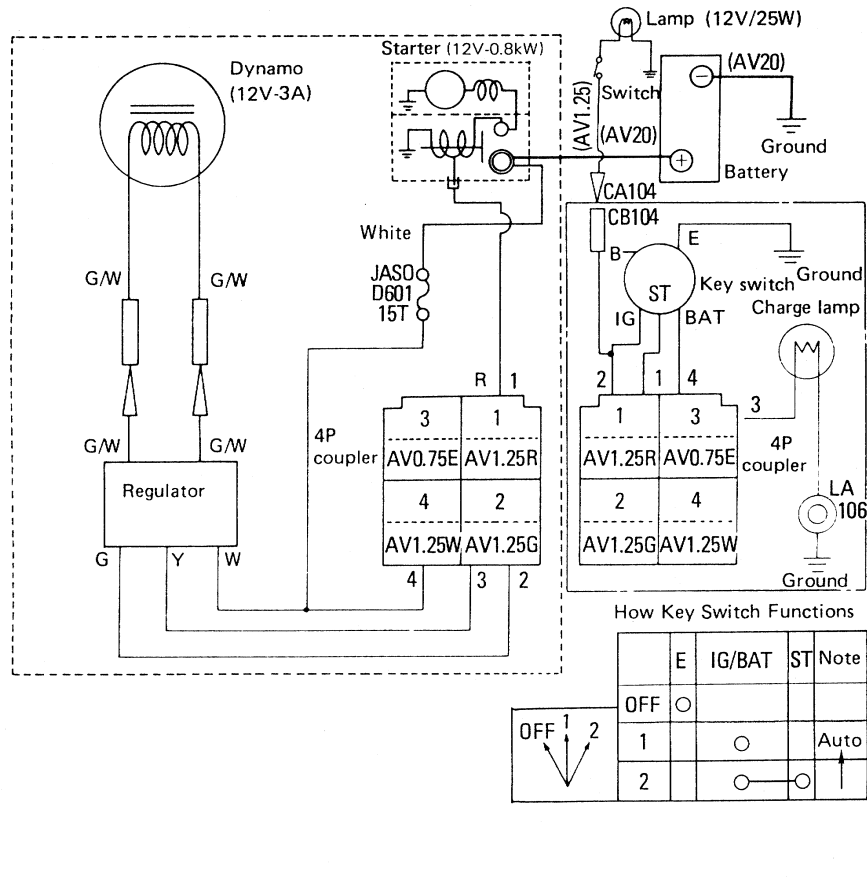
**DIAGRAM KEY**

--- PART OF ENGINE WIRING  
(SEE WISCONSIN DEALER FOR PARTS)

— WIRING SUPPLIED BY  
DIAMANT BOART INC.

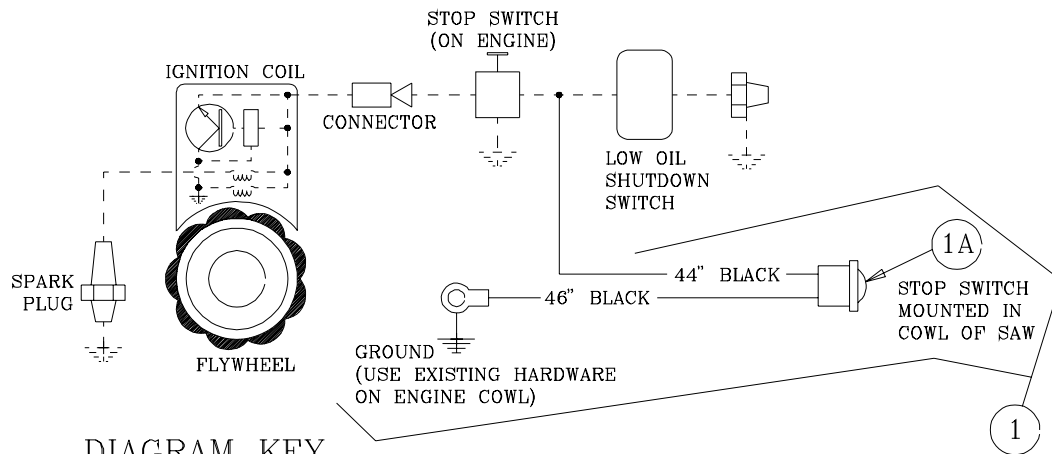
9HP WISCONSIN (AENL2)  
(DB INC. P/N: 011401 ENGINE-9W)  
[WISCONSIN SPEC.#444221 (WAS SPEC.#408483)]

**FIGURE 13 – Wiring Diagram-10Y (10 HP Yanmar Diesel)**



**FIGURE 14 – Wiring Diagram-11R (11 HP Robin)**

1A	1	041317	STOP SWITCH (INCLUDED IN ITEM 1)
1	1	177021	STOP SWITCH ASSY. w/WIRES (11R/13H)
ITEM	QTY	PART NO.	DESCRIPTION
BILL OF MATERIAL-11R ENGINE			



**DIAGRAM KEY**

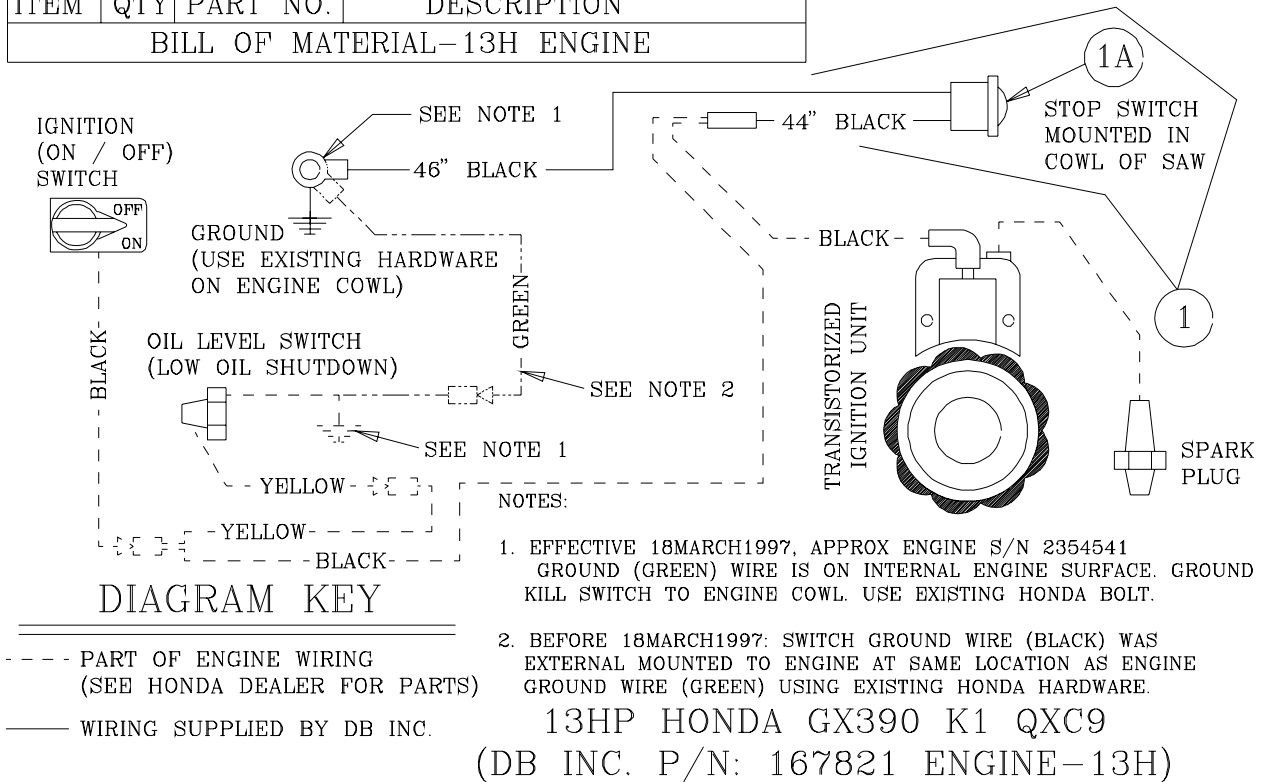
- - - PART OF ENGINE WIRING (SEE ROBIN DEALER FOR PARTS)
- WIRING SUPPLIED BY DB INC.

**WIRING DIAGRAM**

11HP ROBIN EH34 (SPEC # EH340YD0000)  
[DB INC. P/N:162026 (177118-MODIFIED) ENGINE-11R]

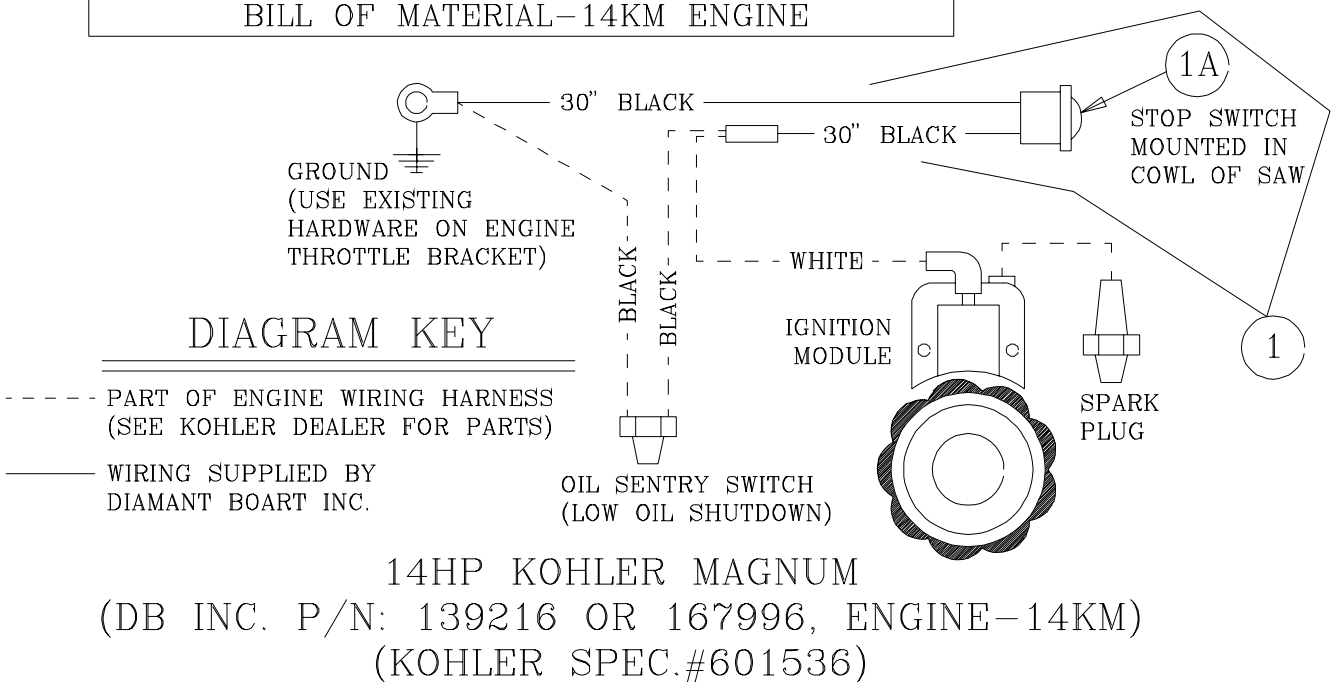
**FIGURE 15 – Wiring Diagram-13H (13 HP Honda)**

1A	1	041317	STOP SWITCH (INCLUDED IN ITEM 1)
1	1	177021	STOP SWITCH ASSY (WITH WIRES)(13H)
ITEM	QTY	PART NO.	DESCRIPTION
BILL OF MATERIAL-13H ENGINE			

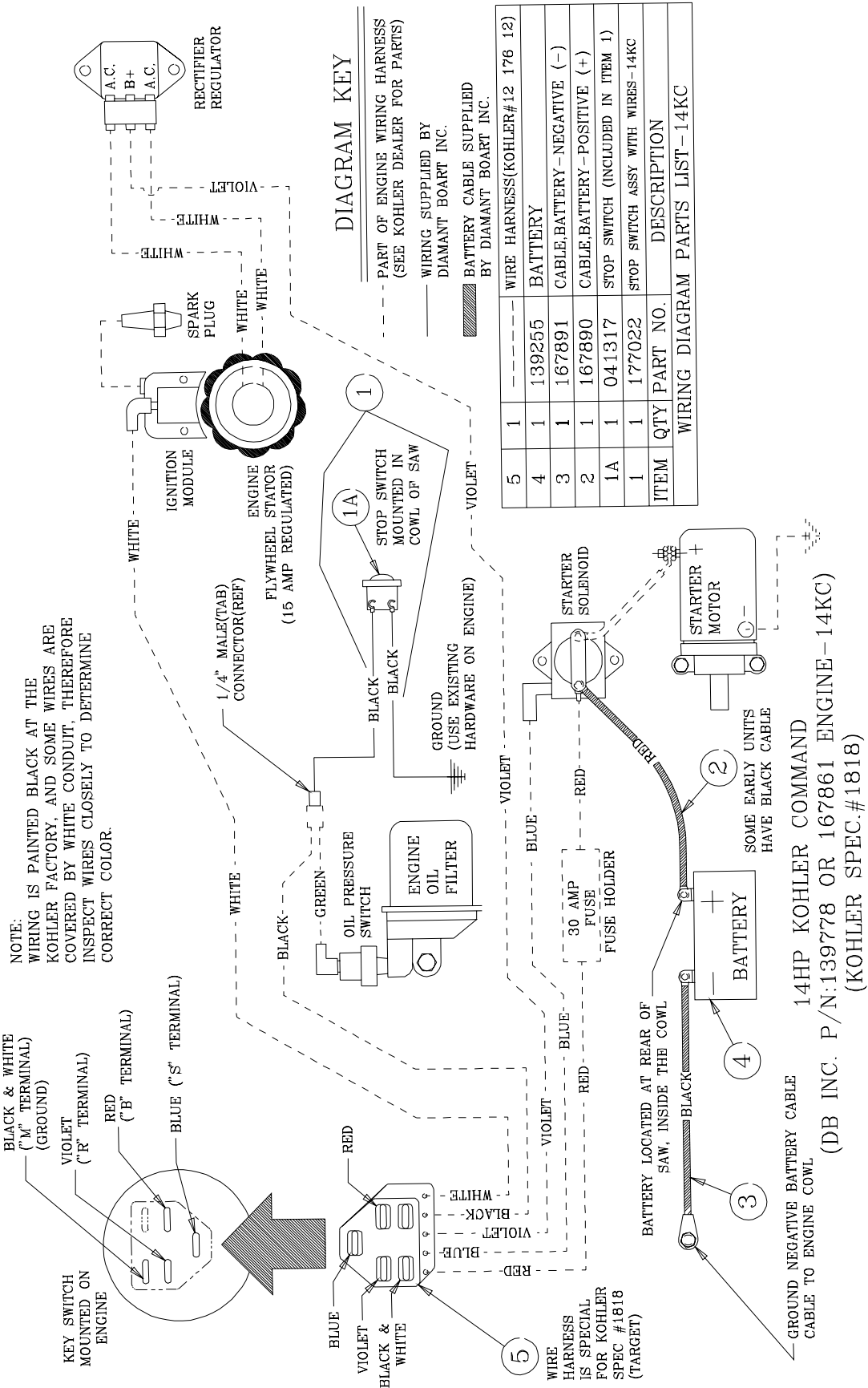


**FIGURE 16 – Wiring Diagram-14KM (14 HP Kohler Magnum – Recoil Start)**

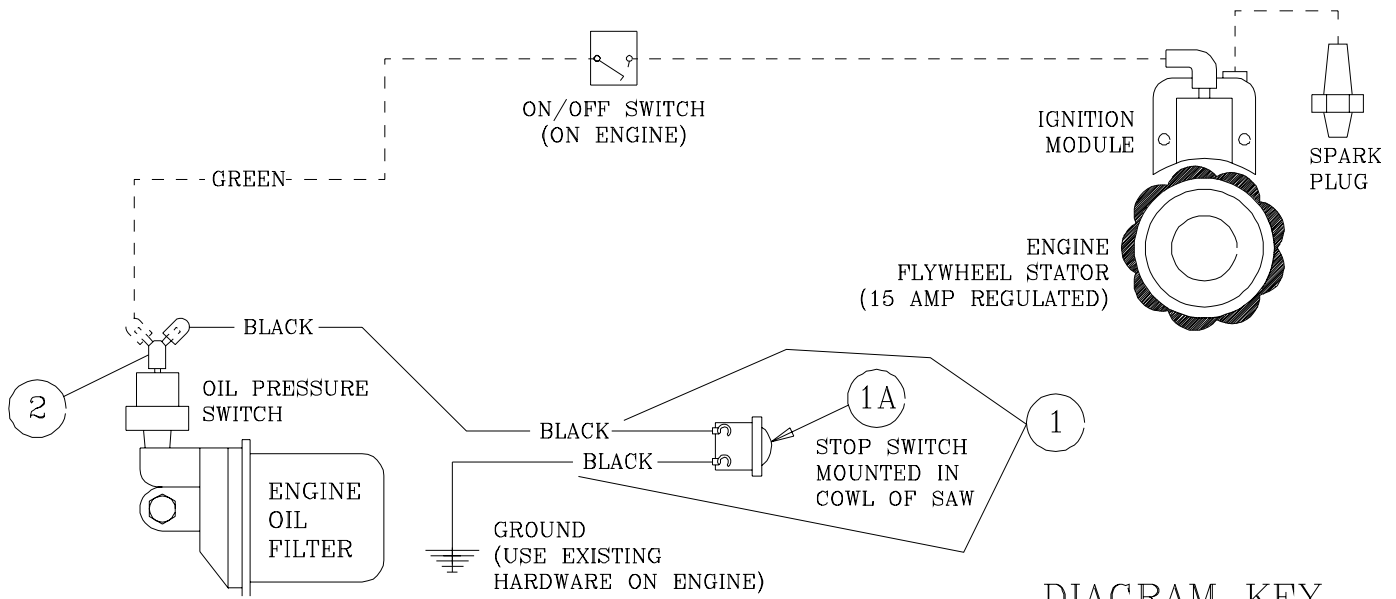
1A	1	041317	STOP SWITCH (INCLUDED IN ITEM 1)
1	1	177023	STOP SWITCH ASSY (WITH WIRES)(14KM)
ITEM	QTY	PART NO.	DESCRIPTION
BILL OF MATERIAL-14KM ENGINE			



**FIGURE 17 – Wiring Diagram-14KC (14 HP Kohler Command – Electric Start)**



**FIGURE 18 – Wiring Diagram-14KCR (14 HP Kohler Command – Recoil Start)**



**DIAGRAM KEY**

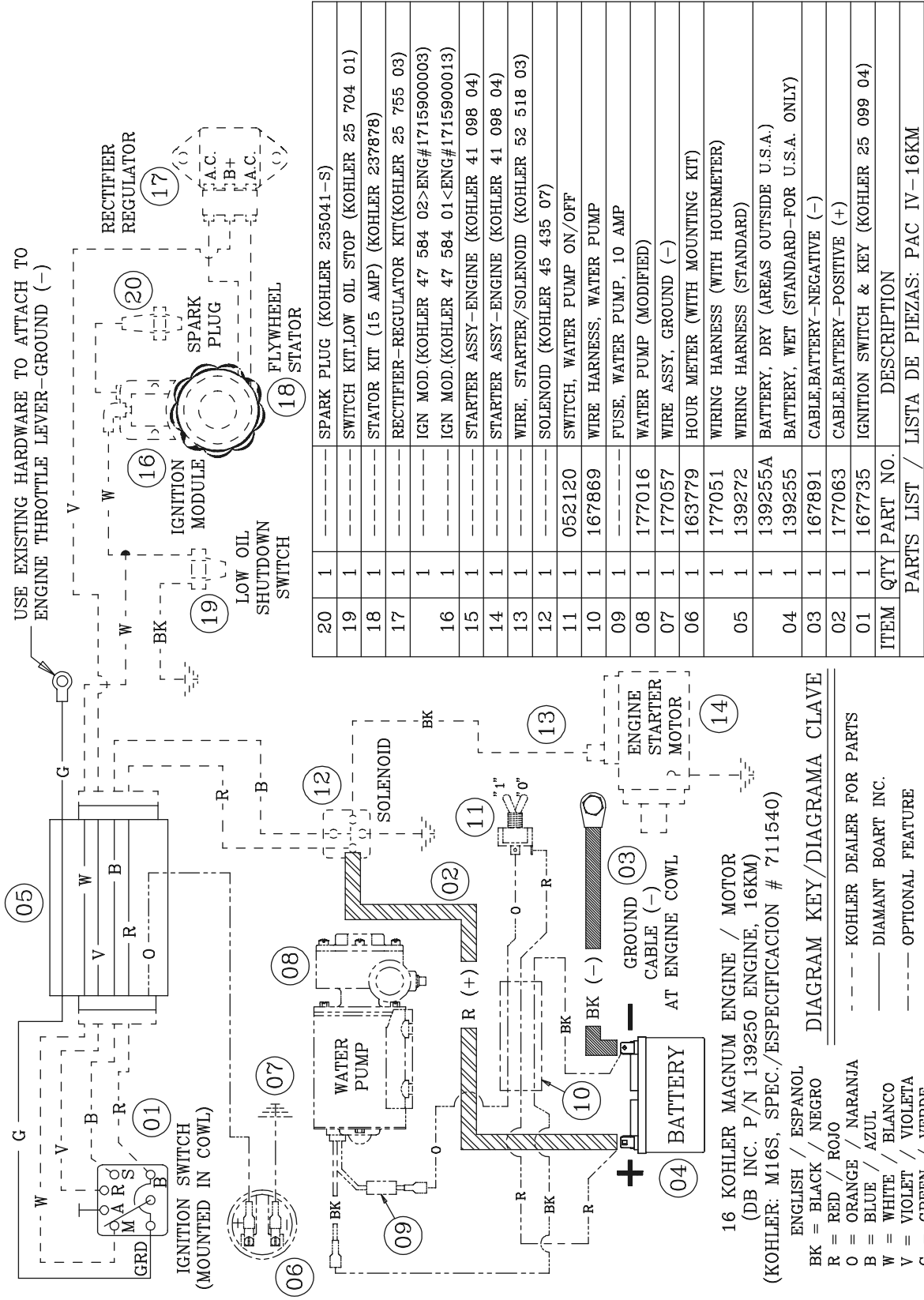
ITEM	QTY	PART NO.	DESCRIPTION
2	1	177613	TERMINAL, PIGGY BACK, 1/4" FEMALE
1A	1	041317	STOP SWITCH (INCLUDED IN ITEM 1)
1	1	177612	STOP SWITCH ASSY WITH WIRES-14KC
WIRING DIAGRAM PARTS LIST-14KC			

- - - - PART OF ENGINE WIRING HARNESS (SEE KOHLER DEALER FOR PARTS)
- WIRING SUPPLIED BY DIAMANT BOART INC.
- ▨ BATTERY CABLE SUPPLIED BY DIAMANT BOART INC.

14HP KOHLER COMMAND-RECOIL START  
 (DB INC. P/N:177607 ENGINE-14KCR)  
 (KOHLER SPEC.#1839)



**FIGURE 19 – Wiring Diagram-16KM (16 HP Kohler Magnum – Electric Start)**



20	1	SPARK PLUG (KOHLER 235041-S)
19	1	SWITCH KIT,LOW OIL STOP (KOHLER 25 704 01)
18	1	STATOR KIT (15 AMP) (KOHLER 237878)
17	1	RECTIFIER-REGULATOR KIT(KOHLER 25 755 03)
16	1	IGN MOD.(KOHLER 47 584 02>ENG#1715900003)
15	1	IGN MOD.(KOHLER 47 584 01<ENG#1715900013)
14	1	STARTER ASSY-ENGINE (KOHLER 41 098 04)
13	1	STARTER ASSY-ENGINE (KOHLER 41 098 04)
12	1	WIRE, STARTER/SOLENOID (KOHLER 52 518 03)
11	1	SOLENOID (KOHLER 45 435 07)
10	1	SWITCH, WATER PUMP ON/OFF
09	1	WIRE HARNESS, WATER PUMP
08	1	FUSE, WATER PUMP, 10 AMP
07	1	WATER PUMP (MODIFIED)
06	1	WIRE ASSY, GROUND (-)
05	1	HOUR METER (WITH MOUNTING KIT)
04	1	WIRING HARNESS (WITH HOURMETER)
03	1	WIRING HARNESS (STANDARD)
02	1	BATTERY, DRY (AREAS OUTSIDE U.S.A.)
01	1	BATTERY, WET (STANDARD-FOR U.S.A. ONLY)
ITEM	QTY	PART NO.
PARTS LIST / LISTA DE PIEZAS: PAC IV-16KM		
DESCRIPTION		

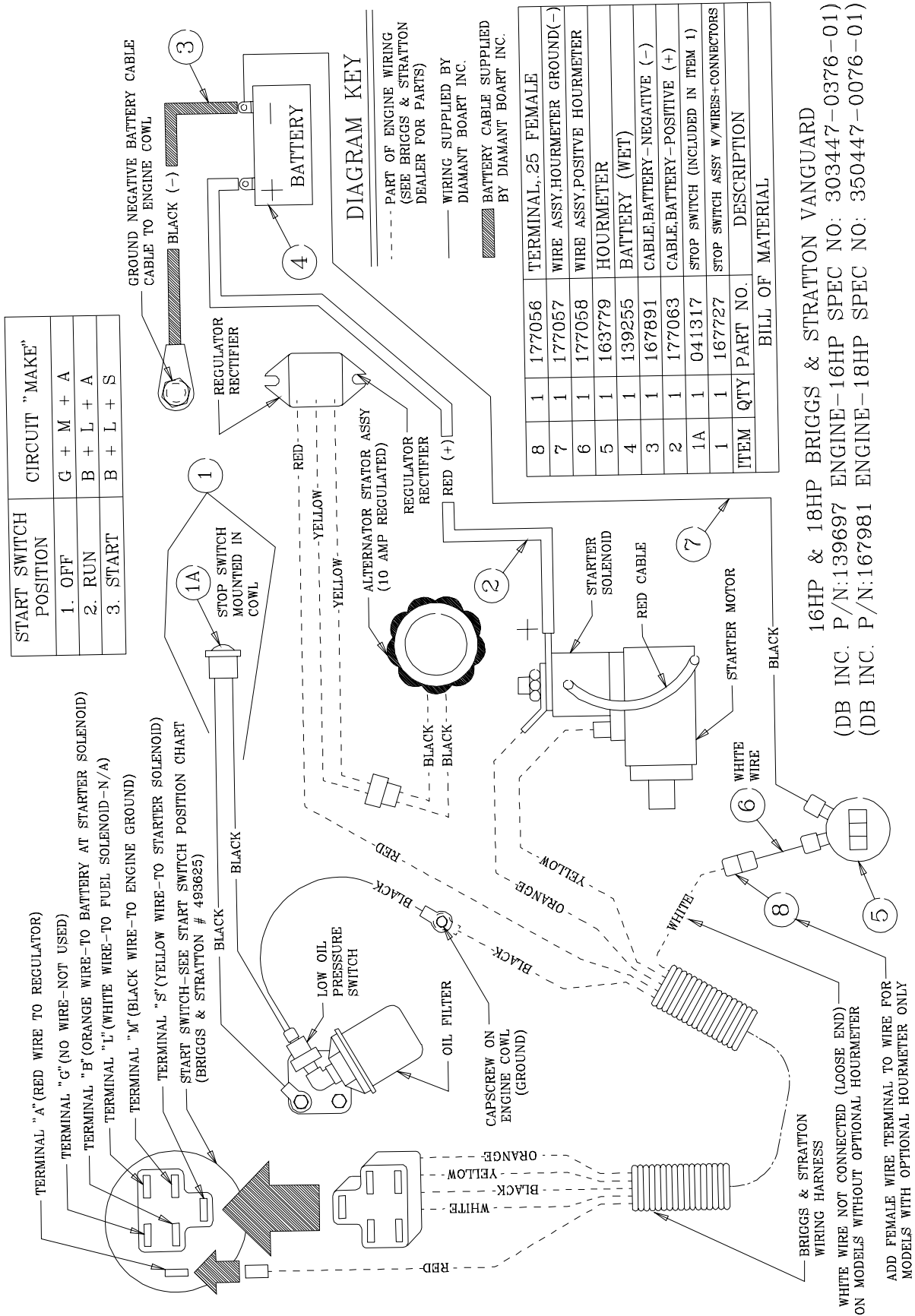
16 KOHLER MAGNUM ENGINE / MOTOR  
(DB INC. P/N 139250 ENGINE, 16KM)  
(KOHLER: M16S, SPEC./ESPECIFICACION # 711540)

ENGLISH / ESPANOL  
BK = BLACK / NEGRO  
R = RED / ROJO  
O = ORANGE / NARANJA  
B = BLUE / AZUL  
W = WHITE / BLANCO  
V = VIOLET / VIOLETA  
G = GREEN / VERDE

DIAGRAM KEY/DIAGRAMA CLAVE

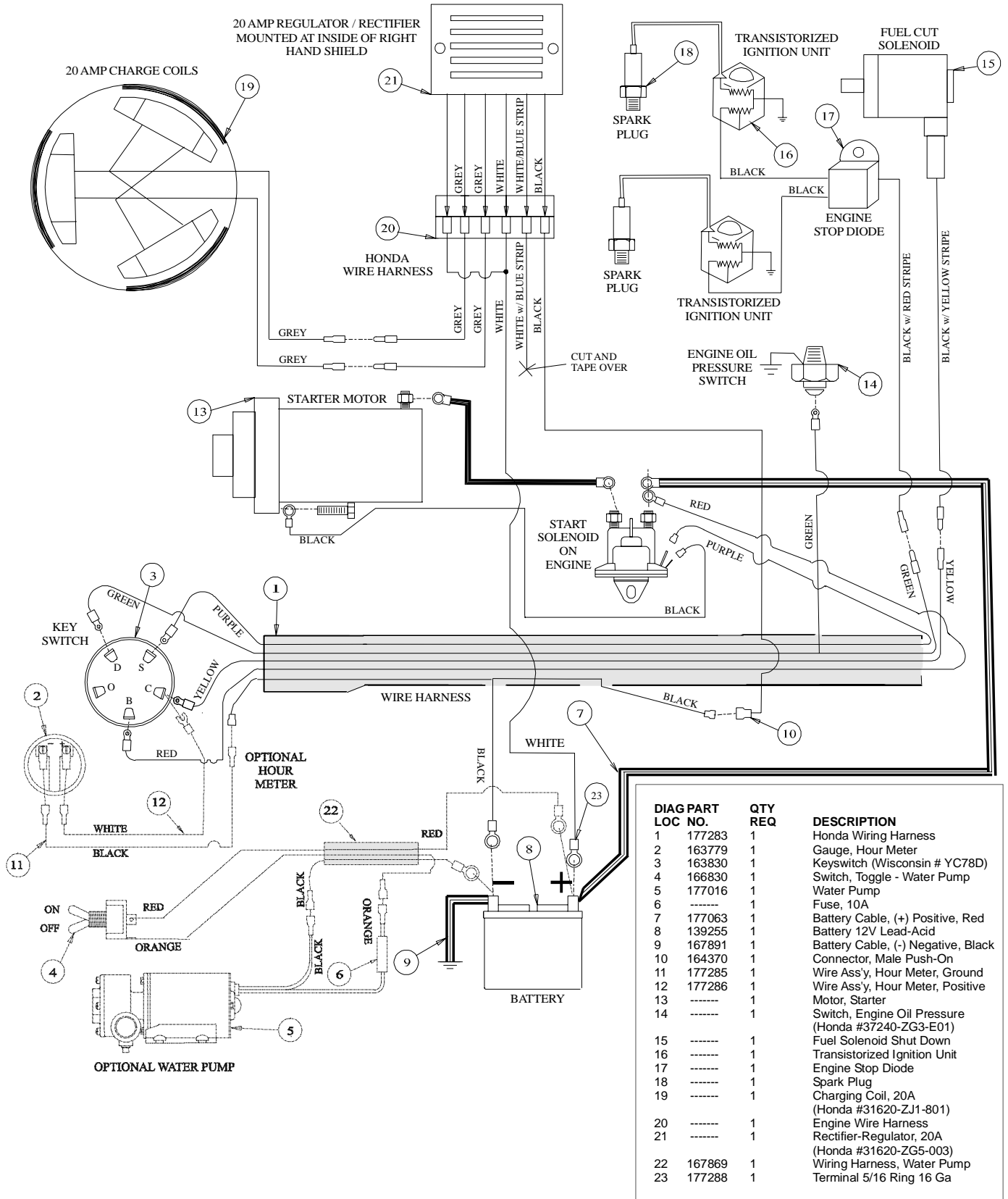
--- KOHLER DEALER FOR PARTS  
— DIAMANT BOARD INC.  
--- OPTIONAL FEATURE

**FIGURE 20 – Wiring Diagram-16BV & 18BV (16 & 18 HP Briggs & Stratton-Vanguard)**



16HP & 18HP BRIGGS & STRATTON VANGUARD  
 (DB INC. P/N:139697 ENGINE-16HP SPEC NO: 303447-0376-01)  
 (DB INC. P/N:167981 ENGINE-18HP SPEC NO: 350447-0076-01)

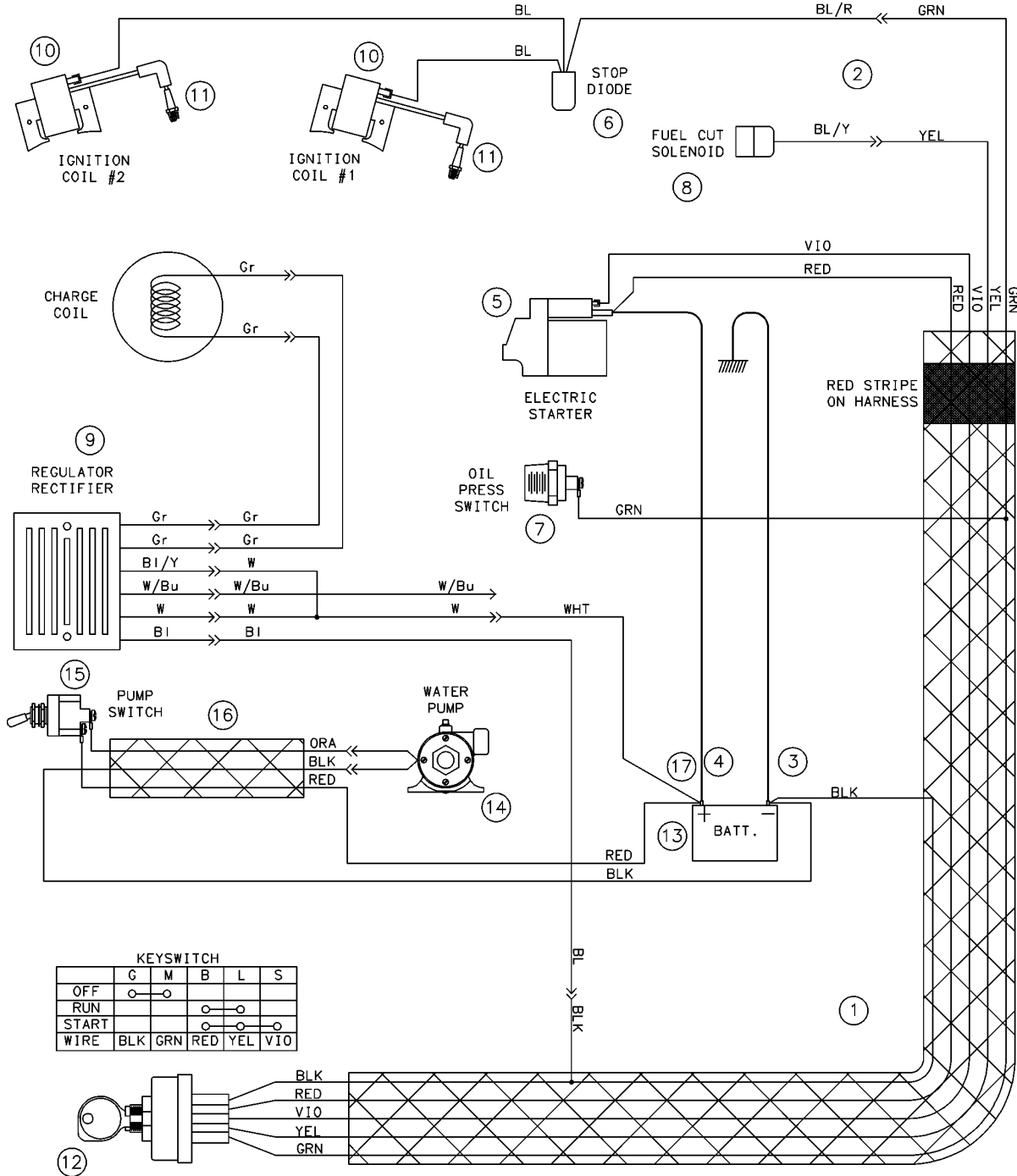
**FIGURE 21 – Wiring Diagram-18H & 20H** (Engine Mounted Fuel Tank & Wire Harness w/o Strip)  
**Wiring Diagram 18 & 20 HP Honda**



DIAG PART LOC NO.	QTY REQ	DESCRIPTION
1 177283	1	Honda Wiring Harness
2 163779	1	Gauge, Hour Meter
3 163830	1	Keyswitch (Wisconsin # YC78D)
4 166830	1	Switch, Toggle - Water Pump
5 177016	1	Water Pump
6 -----	1	Fuse, 10A
7 177063	1	Battery Cable, (+) Positive, Red
8 139255	1	Battery 12V Lead-Acid
9 167891	1	Battery Cable, (-) Negative, Black
10 164370	1	Connector, Male Push-On
11 177285	1	Wire Ass'y, Hour Meter, Ground
12 177286	1	Wire Ass'y, Hour Meter, Positive
13 -----	1	Motor, Starter
14 -----	1	Switch, Engine Oil Pressure (Honda #37240-ZG3-E01)
15 -----	1	Fuel Solenoid Shut Down
16 -----	1	Transistorized Ignition Unit
17 -----	1	Engine Stop Diode
18 -----	1	Spark Plug
19 -----	1	Charging Coil, 20A (Honda #31620-ZJ1-801)
20 -----	1	Engine Wire Harness
21 -----	1	Rectifier-Regulator, 20A (Honda #31620-ZG5-003)
22 167869	1	Wiring Harness, Water Pump
23 177288	1	Terminal 5/16 Ring 16 Ga

**FIGURE 22 – Wiring Diagram-20H** (Engine Mounted Fuel Tank & Red Stripe Wire Harness)

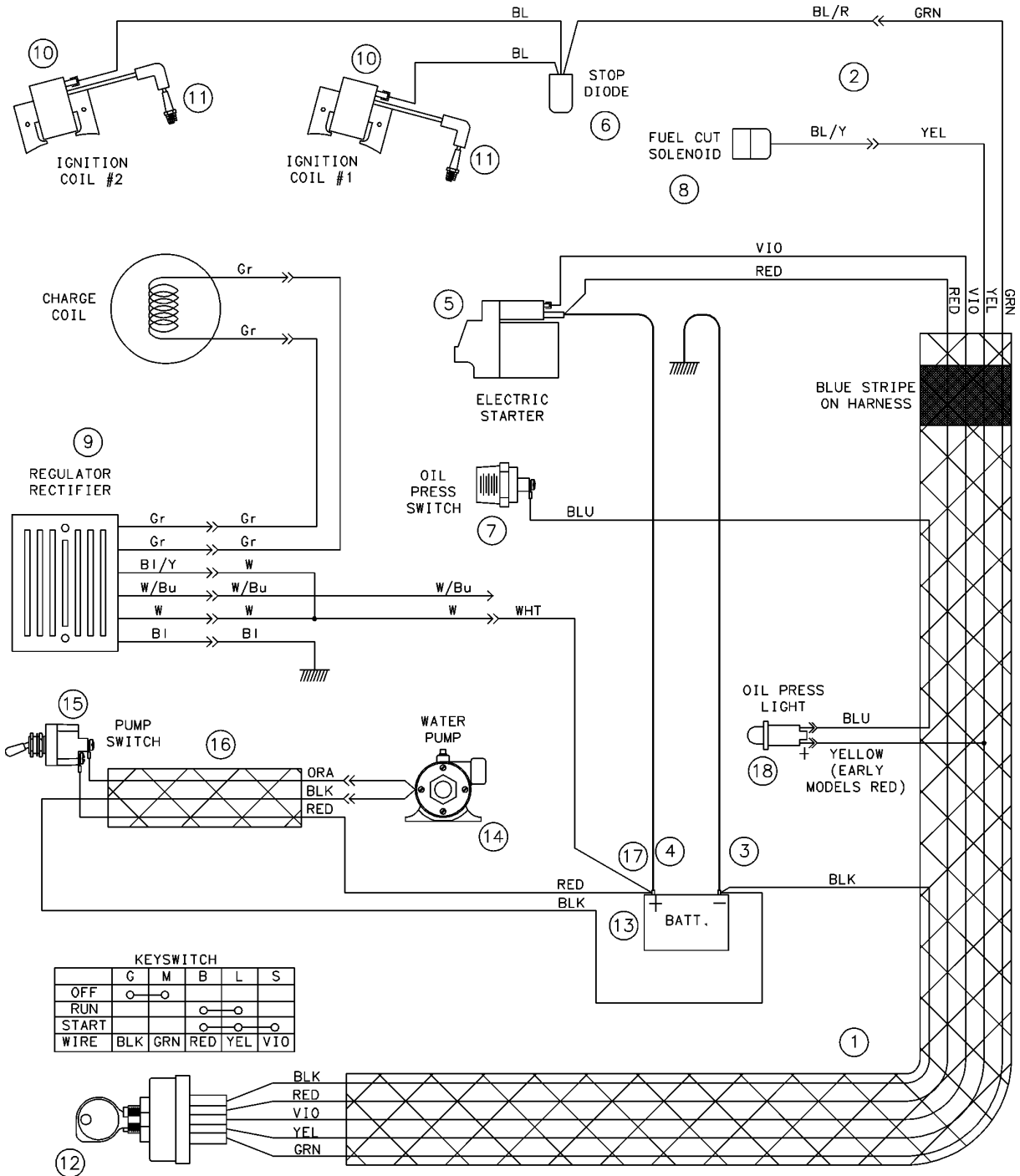
Ref: B-542190398 Wire Diagram



DIAG LOC.	PART NO.	QTY REQ	DESCRIPTION	DIAG LOC.	PART NO.	QTY REQ	DESCRIPTION
1	177913	1	Wiring Harness w/ Red Strip	10	---	2	Coil, Ignition, Honda
2	---	1	Wiring Harness, Honda Engine	11	---	2	Spark Plug, Honda
3	163179	1	Cable, Battery, Negative (-)	12	177920	1	Switch, Ignition
4	177063	1	Cable, Battery, Positive (+)	13	139255	1	Battery, 12 Volt
5	---	1	Starter, Honda Engine	14	177016	1	Waterpump (Optional)
6	---	1	Stop Diode, Honda	15	166830	1	Switch, Toggle (Waterpump Option)
7	---	1	Switch, Engine Oil Pressure, Honda	16	167869	1	Wire Harness, Waterpump
8	---	1	Fuel Cut Solenoid, Honda	17	177288	1	Terminal, Ring, 5/16" – 16 Ga
9	---	1	Regulator, Honda	18	---	---	---

**FIGURE 23 – Wiring Diagram-20H** (Cowl Mounted Fuel Tank, 190092 Engine, & Blue Stripe Wire Harness)

Ref: B-542190399, Rev 2 Wire Diagram



DIAG LOC.	PART NO.	QTY REQ	DESCRIPTION	DIAG LOC.	PART NO.	QTY REQ	DESCRIPTION
1	542190390	1	Wiring Harness w/ Blue Strip	10	---	2	Coil, Ignition, Honda
2	---	1	Wiring Harness, Honda Engine	11	---	2	Spark Plug, Honda
3	163179	1	Cable, Battery, Negative (-)	12	177920	1	Switch, Ignition
4	542190395	1	Cable, Battery, Positive (+)	13	139255	1	Battery, 12 Volt
5	---	1	Starter, Honda Engine	14	177016	1	Waterpump (Optional)
6	---	1	Stop Diode, Honda	15	166830	1	Switch, Toggle (Waterpump Option)
7	---	1	Switch, Engine Oil Pressure, Honda	16	167869	1	Wire Harness, Waterpump
8	---	1	Fuel Cut Solenoid, Honda	17	177288	1	Terminal, Ring, 5/16" - 16 Ga
9	---	1	Regulator, Honda	18	542190401	1	Light, Low Oil Indicator

**DECAL DESCRIPTIONS AND LOCATIONS**  
**DESCRIPCIÓN DE CALCAMONIAS Y UBICACIONES**

# TARGET

## PORTACUT IV

P/N: 187681  
 Target / PAC IV  
 Location: Sides of Cowl  
 Quantity: 2  
 Models: All



P/N: 167936  
 Start / Run / Stop  
 Location: Control Panel  
 Quantity: 1  
 Models: 16KM, 18H, 20H (Drivematic Only)

# TARGET

P/N: 189732, Target (Blue) for Blue Surfaces  
 (Shown)  
 Or  
 P/N: 187693, Target (White) for Black Surfaces

Location: Rear Guard At Rear Of Cowl  
 Quantity: 1  
 Models: All



P/N: 169065, Muffler Hot  
 Location: Engine Fuel Tank  
 Quantity: 1  
 Models: Gasoline Powered Models

**OPERATING INSTRUCTIONS**

Before Starting Engine:

1. Use correct diamond of abrasive blade for the cutting conditions.
2. Ensure flanges and blade mount are clean and undamaged, then mount blade and secure tightly.
3. Check water tubes for adequate water flow.
4. On self-propelled models, disengage transmission.

To Start Sawing:

1. Start Engine, let engine warm up at half-throttle. All sawing is done at full throttle.
2. Align blade with cut. For wet cutting, open water valve. Lower blade into cut.
3. Cut as fast as blade will allow. If blade climbs out of cut, reduce forward speed, or cutting depth.

**INSTRUCCIONES DE OPERACION**

Antes de la puesta en marcha:

1. Utilizar el disco de diamante o abrasivos adecuados.
2. Las pletinas de sujecion del disco, deben estar limpias y sin golpes. Colocar el disco y ajustarlo solidamente.
3. Asegurarse de una refrigeracion del disco suficiente. Comprobar la limpieza de la horquilla de salida del agua.
4. En Modelos autopropulsados, desembragar la transmision.

Para empezar el corte:

1. Arrancar el motor, dejandolo calentarse a medio regimen. El corte se hace a pleno regimen.
2. Alinear el disco con el corte. para corte conagua, abrir la llave de paso. Boyar lentamente el disco hasta el corte.
3. Cortar tan deprisa como el disco lo permita. Si el disco tiende a levantarse, saliendo de el corte, Reducir la velocidad de avance o la profundidad de corte.

LOWER  
BAJADA

RAISE  
SUBIDA

**WARNING**  
 ADVERTENCIA  
 AVERTISSEMENT

Always wear approved equipment.  
 Utilize siempre protecciones homo logadas.

Read manual.  
 Lea el manual.  
 Veuillez lire le manuel.

**IF YOU DO NOT HAVE AN OPERATOR'S MANUAL  
 CALL TOLL FREE 1-800-288-5040.**

Machinery Hazard -Always keep all guards in place.  
 Maquina en funcionamiento-Los capotes debenestar en posicion.

DO NOT operate near combustible material.  
 No utilizar dentro de un lugar inflamable.

Use only in well ventilated areas.  
 Utilizar en un lugar muy bien ventilado.

STOP  
ENGINE

RUN  
MARCHA

START  
ARRANQUE

STOP  
MOTOR

P/N 177891, Operating Instructions  
 Location: Top Of Control Panel  
 Quantity: 1, Models: All

# DECAL DESCRIPTIONS AND LOCATIONS DESCRIPCIÓN DE CALCAMONIAS Y UBICACIONES

GREASE BEARINGS DAILY  
LAGER TÄGLICH FETTEN

DE LAGERS DAGELIJKS SMEREN  
GRAISSER LES ROUEMENTS CHAQUE JOUR

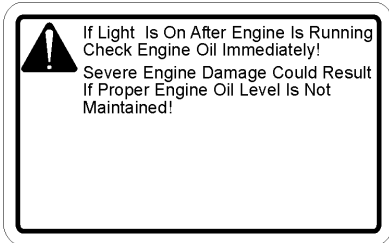
ENGRASAR LOS RODAMIENTOS A DIARIO  
INGRASSARE I CUSCINETTI OGNI GIORNO

040570

P/N 040570, Grease Bearings Daily (Multi-Language)

Location: Front Of Frame or Front Of Weight Kit

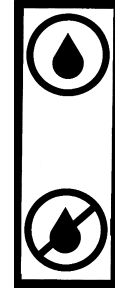
Quantity: 1, Models: All



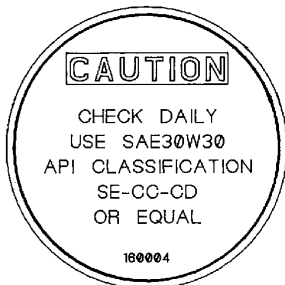
P/N 542190402,  
Decal, Low Oil Indicator Light  
Location: Near Lamp On Fuel  
Tank Bracket, Quantity: 1  
Models: 20H Models Only



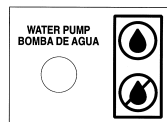
P/N 167952, Transmission  
Engage  
Location: Rear Of Control Panel  
Quantity: 1  
Models: Drivematic Models  
Only



P/N 167951, Water Valve ON /  
OFF  
Location: Rear Of Control  
Panel  
Quantity: 1  
Models: All



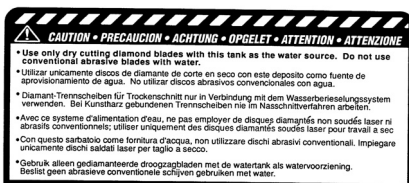
P/N 160004, Transmission  
Location: Transmission Fill Cap  
Quantity: 1  
Models: Drivematic Models Only



P/N 167935, Decal, Water  
Pump  
Location: Rear Of Control Panel  
Quantity: 1 for Water Pump  
Equipped Models



P/N 176223 Decal, Warning-  
Guards In Place  
Location: Frame Base, Rear  
Control Panel, Quantity: 2, All  
Models



P/N 167755 Decal, Water Tank  
Caution  
Location: Water Tank Bracket  
Quantity: 1 for Water Tank  
Option Only

**TARGET**  
TARGETBLUE.COM

P/N 187691, Decal,  
Targetblue.com  
Location: Cowl Front, Near S/N  
Plate  
Quantity: 1 for All Models

## COMPLETE DECAL KITS

<b>P/N 177561 Decal Kit PAC IV, Drivematic Model</b>			<b>P/N 177562 Decal Kit PAC IV, Push Model</b>		
Includes the following items**:			Includes the following items**:		
Part No.	Qty	Description	Part No.	Qty	Description
167953	2	Decal, Target / PAC IV	167953	2	Decal, Target / PAC IV w/ Stripe
052130	1	Decal, Target	052130	1	Decal, Target
167951	1	Decal, Water Valve ON / OFF	167951	1	Decal, Water Valve ON / OFF
176223	2	Decal, Caution / Guards In Place	176223	2	Decal, Caution / Guards In Place
169065	1	Decal, Muffler Hot	169065	1	Decal, Muffler Hot
040570	1	Decal, Grease Bearings Daily	040570	1	Decal, Grease Bearings Daily
167949	1	Decal, Operating Instr. (Drivematic)	167950	1	Decal, Operating Instr. (Push Model)
167936	1	Decal, Start / Run / Stop			
167952	1	Decal, Transmission Engage			
160004	1	Decal, Transmission Oil Fill			

\*\*Kits Includes P/N's Shown & Quantity To Complete One Unit. Specify Kit For A Drivematic or Push Model Saw. Kits DO NOT Include Decals For Optional Water Pump, or Optional Water Tank – Order Separately. Kits DO NOT Include Decals For Engine or Electric Motor. See The Engine / Motor Manufacturer For These Decals.

## EQUIPOS COMPLETOS DE CALCOMANIAS

<b>Equipo de Calcomanía P/N 177561 PAC IV, Modelo de Transmisión Automática</b>			<b>Equipo de Calcomanía P/N 177562 PAC IV, Modelo de Empuje</b>		
Incluye los siguientes artículos**:			Incluye los siguientes artículos**:		
Pieza No.	Cantidad	Descripción	Pieza No.	Cantidad	Descripción
167953	2	Calcomanía, Target / PAC IV	167953	2	Calcomanía, Target / PAC IV con Raya
052130	1	Calcomanía, Target	052130	1	Calcomanía, Target
167951	1	Calcomanía, Válvula de Agua ENCENDIDO / APAGADO	167951	1	Calcomanía, Válvula de Agua ENCENDIDO / APAGADO
176223	2	Calcomanía, Precaución / Protectores en su Sitio	176223	2	Calcomanía, Precaución / Protectores en su Sitio
169065	1	Calcomanía, Silenciador Caliente	169065	1	Calcomanía, Silenciador Caliente
040570	1	Calcomanía, Engrase los Cojinetes Diariamente	040570	1	Calcomanía, Engrase los Cojinetes Diariamente
167949	1	Calcomanía, Instrucciones de Operación (Transmisión Automática)	167950	1	Calcomanía, Instrucciones de Operación (Modelo de Empuje)
167936	1	Calcomanía, Arranque / Funcionamiento / Parada			
167952	1	Calcomanía, Engranaje de la Transmisión			
160004	1	Calcomanía, Llenado del Aceite de Transmisión			

\*\*Los equipos incluyen las P/N mostradas y la cantidad para completar una unidad. Especificar el equipo para una sierra de transmisión automática o modelo de empuje. Los equipos NO incluyen calcomanías para la bomba de agua opcional o para el tanque de agua opcional. Haga su pedido por separado. Los equipos NO incluyen calcomanías para la máquina o el motor eléctrico. Refiérase al fabricante del motor / máquina para obtener estas calcomanías..





**Notes:**

---

---

---

---

---

---

---

---

---

---

OPTION AVAILABILITY FOR EACH MODEL																
OPTIONS	MODEL															
	51E	53E	75E	8KM	9W	10Y	11R	13H	14KM	14KC	14KCR	16KM	16BV	18BV	18H	20H
Drivematic Transmission	N/A	N/A	Y	Y	Y	Y	Y	Y	Y	Y	Y	Y	Y	Y	Y	Y
Weight Kit (26 Lbs.) (Note 1)	Y	Y	Y	Y	Y	Y	Y	Y	Y	Y	Y	Y	Y	Y	Y	Y
Lift Bail Kit (Note 2)	Y	Y	Y	Y	Y	Y	Y	Y	Y	Y	Y	Y	Y	Y	Y	N/A
Tie Down Bracket Kit	Y	Y	Y	Y	Y	Y	Y	Y	Y	Y	Y	Y	Y	Y	Y	Y
Water Tank Kit (5 Gal.) (Note 3)	Y	Y	N/A	Y	Y	Y	Y	Y	Y	Y	Y	Y	Y	Y	Y	N/A
Outer Flange – 1/2" Cut (Note 4)	N/R	N/R	N/R	N/R	N/R	N/R	N/R	Y	Y	Y	Y	Y	Y	Y	Y	Y
Kit, 3/4" Cut (Note 5)	N/R	N/R	N/R	N/R	N/R	N/R	N/R	N/R	N/R	N/R	N/R	Y	Y	Y	Y	Y
Kit, 1" Cut (Note 5)	N/R	N/R	N/R	N/R	N/R	N/R	N/R	N/R	N/R	N/R	N/R	N/R	N/R	N/R	N/R	Y
Electric Water Pump (Note 6)	N/A	N/A	N/A	N/A	N/A	Y	N/A	N/A	N/A	Y	N/A	Y	Y	Y	Y	Y
Hourmeter Kit (Note 6)	N/A	N/A	N/A	N/A	N/A	Y	N/A	N/A	N/A	Y	N/A	Y	Y	Y	Y	Y
Blade Guard Left / Right Cutting																
14" Blade Guard (Note 7)	L/R	L/R	L/R	L/R	L/R	L/R	L/R	L/R	L/R	L/R	L/R	L/R	L/R	L/R	L/R	L/R
18" Blade Guard (Note 8)	L/R	L/R	L/R	L	L	L/R	L/R	L/R	L/R	L/R	L/R	L/R	L/R	L/R	L/R	L/R
20" Blade Guard	L	L	L	L	L	L/R	L/R	L/R	L	L/R	L/R	L/R	L/R	L/R	L/R	L/R

**Y** = Available      **N/A** = Not Available (Item will NOT work on this model)      **N/R** = Available but Not Recommended  
**L** = This Size Blade Guard Will Fit Only On Left Hand Side Of Saw      **L/R** = This Size Blade Guard Will Fit On Left or Right Side Of Saw

**Notes:**  **Warning: See operating instructions and applicable instruction sheets before installation of any of these items!**

- Weight Kit:** Standard Equipment for 51E, 53E, 11R, 13H, 14KC, 16BV, 18BV, 18H, 20H With 18" Blade Guard (See Note 7 & 8). Installation: See parts list.
- Lift Bail Kit:** Available As Factory Installed (most models). Standard equipment for 75E model because electrical control box is mounted onto lift bail (effective January 1997). This option must be ordered to use the optional "Water Tank Kit" (See Note 3). See Instruction Sheet 0A7673 for installation instructions.
- Water Tank Kit:** Must order Lift Bail Kit to use water tank kit. Use only with dry cutting blades. Water flow (Approx. 1/2 Gallon Per Minute) is not sufficient for use with wet cutting diamond blades. N/A for 75E models because electric control box is mounted onto lift bail. Installation: See parts list.
- Outer Flange 1/2" Cutting:** Mounts directly to standard bladeshaft. Use Only For Blade Stacking Width Of 7/16"– 1/2". Use Standard Outer Flange (P/N 167962) For Blade Stacking Width Of 0 – 3/8". Available For Use On Right Or Left Side Of Saw.
- Wide Cutting Kits:** Available for all Models. Not recommended for engine sizes less than 16 HP (4 Belt Bladeshaft Drive). Kit Includes A 4 Groove Blade Shaft Pulley. N/R Engines Require A 3 Groove Bladeshaft Pulley-Order & Install Separately. See Instruction Sheet 0A7767.
- Electric Water Pump Kit / Hourmeter Kit:** Available only on models shown. Engine must have electric starter to power this item. Installation: See parts list.
- 14" Blade Guard:** Not Available For Factory Installation--effective January 1997. Available Through Service Parts Only.
- 18" Blade Guard:** Standard Equipment--effective January 1997 For All Models except for 20H (20H Model Equipped with a 20" Blade Guard).

## DISPONIBILIDAD DE OPCIONES PARA CADA MODELO

OPCIONES	MODELO															
	51E	53E	75E	8KM	9W	10Y	11R	13H	14KM	14KC	14KCR	16KM	16BV	18BV	18H	20H
Transmisión Automática	N/D	N/D	D	D	D	D	D	D	D	D	D	D	D	D	D	D
Equipo de Pesas (26 Libras) (Nota 1)	D	D	D	D	D	D	D	D	D	D	D	D	D	D	D	D
Equipo de Elevación (Nota 2)	D	D	D	D	D	D	D	D	D	D	D	D	D	D	D	N/D
Equipo de Ménsula de Atar	D	D	D	D	D	D	D	D	D	D	D	D	D	D	D	D
Equipo de Tanque de Agua (5 Galones) (Nota 3)	D	D	N/D	D	D	D	D	D	D	D	D	D	D	D	D	N/D
Brida Externa - Corte de 1/2" (Nota 4)	N/R	N/R	N/R	N/R	N/R	N/R	N/R	D	D	D	D	D	D	D	D	D
Equipo, Corte de 3/4" (Nota 5)	N/R	N/R	N/R	N/R	N/R	N/R	N/R	N/R	N/R	N/R	N/R	D	D	D	D	D
Equipo, Corte de 1" (Nota 5)	N/R	N/R	N/R	N/R	N/R	N/R	N/R	N/R	N/R	N/R	N/R	N/R	N/R	N/R	N/R	D
Bomba de Agua Eléctrica (Nota 6)	N/D	N/D	N/D	N/D	N/D	D	N/D	N/D	N/D	D	N/D	D	D	D	D	D
Equipo Medidor de Horas (Nota 6)	N/D	N/D	N/D	N/D	N/D	D	N/D	N/D	N/D	D	N/D	D	D	D	D	D
Protector de Hoja Izquierdo / Corte a la Derecha																
Protector de Hoja de 14" (Nota 7)	I/D	I/D	I/D	I/D	I/D	I/D	I/D	I/D	I/D	I/D	I/D	I/D	I/D	I/D	I/D	I/D
Protector de Hoja de 18" (Nota 8)	I/D	I/D	I/D	I	I	I/D	I/D	I/D	I/D	I/D	I/D	I/D	I/D	I/D	I/D	I/D
Protector de Hoja de 20"	I	I	I	I	I	I/D	I/D	I/D	I	I/D	I/D	I/D	I/D	I/D	I/D	I/D

**D** = Disponible      **N/D** = No Disponible (El artículo NO funcionará en este modelo)      **N/R** = Disponible pero No Recomendado  
**I** = Este tamaño de protector de hoja se ajustará solamente a la izquierda de la sierra      **I/D** = Este tamaño de protector de hoja se ajustará al costado izquierdo o derecho de la sierra



**Notas: Advertencia: ¡Ver las instrucciones de operación y las hojas de instrucciones aplicables antes de instalar cualquiera de estos artículos!**

1. **Equipo de Pesas:** Equipo convencional para los modelos 51E, 53E, 11R, 13H, 14KC, 16BV, 18BV, 18H, 20H con Protector de Hoja de 18" (Ver Nota 7 y 8). Instalación: Ver la lista de piezas.
2. **Equipo de Elevación:** Disponible como instalación en fábrica (en la mayoría de los modelos). Equipo convencional para el modelo 75E porque la caja de control eléctrico está montada en el mecanismo de elevación (efectivo en enero de 1997). Se debe hacer el pedido de esta opción para usar el "Equipo del Tanque de Agua" opcional (Ver Nota 3). Ver Hoja de Instrucción 0A7673 para obtener las instrucciones de instalación.
3. **Equipo del Tanque de Agua:** Se debe hacer el pedido del Equipo de Elevación para usar el equipo del tanque de agua. Usar solamente con hojas para corte en seco. El Flujo de Agua (Aproximadamente 1/2 Galón Por Minuto) no es suficiente para usar con hojas diamantadas húmedas. N/D para los modelos 75E porque la caja de control eléctrico está montada en el mecanismo de elevación. Instalación: Ver lista de piezas.
4. **Corte de 1/2" de la Brida Externa:** Se monta directamente al eje de la hoja convencional. Usar solamente para el amontonamiento de hojas de ancho de 7/16" – 1/2". Usar Brida Externa Convencional (P/N 167962) para el amontonamiento de hojas de ancho 0 – 3/8". Disponible para uso en el costado derecho o izquierdo de la sierra.

5. **Equipos para Corte Ancho:** Disponibles para todos los modelos. No recomendados para tamaños de motor inferiores a 16 HP (Transmisión del Eje de la Hoja de 4 Bandas). El equipo incluye una Polea del Eje de la Hoja de Muesca A 4. Los motores N/R requieren Poleas del Eje de la Hoja de Muesca A 3 - Haga el pedido por separado e instale en forma separada. Ver la Hoja de Instrucción 0A7767.
6. **Equipo de Bomba de Agua Eléctrica / Equipo Medidor de Horas:** Disponible solamente en los modelos mostrados. El motor debe tener un arrancador eléctrico para suministrar energía a este artículo. Instalación: Ver lista de piezas.
7. **Protector de Hoja de 14":** No disponible para instalación en fábrica--efectivo en enero de 1997. Disponible a través de Piezas de Servicio solamente.
8. **Protector de Hoja de 18":** Equipo Convencional--efectivo en enero de 1997 para todos los modelos excepto para el 20H (el modelo 20H está equipado con un Protector de Hoja de 20").

## REPAIRS

We carry out all repairs in the shortest possible time and at the most economical prices. (See front page for our address and phone numbers)

## SPARE PARTS

For quick supply of spare parts and to avoid any lost time, it is essential to quote the data on the manufacturer's plate fixed to the machine and the part number (s) to be replaced with every order.

## REPARACIONES

Hacemos todas las reparaciones en los plazos más breves posibles, y a los precios más económicos. (Vea la portada para nuestra dirección y número de teléfono).

## PIEZAS DE RECAMBIO

Para un suministro rápido de piezas de recambio y evitar cualquier pérdida de tiempo, en cada pedido es esencial mencionar los datos de la placa de fabricación fijada a la máquina; y el número de pieza que se va a reemplazar.

*The instructions for use and spare parts found in this document are for information only and are not binding. As part of our product quality improvement policy, we reserve the right to make any and all technical modifications without prior notice.*

*Las instrucciones de uso y las piezas de recambio presentadas en este documento son solamente para información y no constituyen obligación ninguna. Como parte de nuestra política de mejoramiento de la calidad de nuestros productos, nos reservamos el derecho de hacer cualquiera y todas las modificaciones técnicas sin previo aviso.*



**The manufacturer accepts no responsibility caused by unsuitable use or modifications**



**¡El fabricante no acepta ninguna responsabilidad por accidentes debidos al uso indebido o modificaciones hechas a la máquina!**

**Notes:**

---

---

---

---

---

---

---

---

---

---



# TARGET



## WARNINGS:



The engine exhaust from this product contains chemicals known to the State of California to cause cancer, birth defects or other reproductive harm.



Printed on Recycled Paper