

Alvaline

For m

**istruzioni di montaggio
installing instructions
Gebrauchsanweisung
instructions de montage
instrucciones de montaje**

13x8

Viabizzuno

progettiamo la luce

- IT AVVERTENZE:** All'atto dell'installazione, ed ogni volta che si interviene sulla lampada, assicurarsi che sia stata tolta la tensione di alimentazione. Le operazioni di installazione e collegamento alla rete elettrica devono essere effettuate esclusivamente da personale qualificato.
- GB WARNING:** When installing fixture and during unkeep take care that the mains voltage is switched off. The operations of installation and connection to power mains should be done by skilled personnel only.
- DE HINWEISE:** Während der Installation und bei allen nachfolgenden Arbeiten auf der Lampe sollte sichergestellt werden, daß die Versorgungsspannung vorher abgenommen wurde. Die Arbeiten zur Installation und zum Anschluss an das Stromnetz sind von Fachpersonal durchzuführen.
- FR AVERTISSEMENTS:** Lors de l'installation et à chaque fois que l'on fait un entretien sur la lampe, s'assurer que la tension d'alimentation ait été coupée. Les opérations d'installation et de branchement au réseau électrique doivent être effectuées par un personnel qualifié.
- ES ADVERTENCIA:** Durante la instalación, y cada ve que se interviene sobre la lámpara, asegurarse que la alimentación haya sido desconectada. Las operaciones de instalación y conexión a la red eléctrica tienen que ser efectuadas exclusivamente por personal cualificado.

IT ATTENZIONE:

La sicurezza dell'apparecchio è garantita solo rispettando queste istruzioni sia in fase di installazione che di impiego.

GB WARNING:

Fitting safety is only guaranteed if the following instructions are strictly observed both during installation and use.

DE ACHTUNG:

Für die Sicherheit des Geräts kann nur dann die Garantie übernommen werden, wenn die in den vorliegenden Anweisungen enthaltenen Hinweise sowohl bei der Installation als auch beim Betrieb beachtet werden.

FR ATTENTION:

La sécurité de l'appareil n'est assurée que lorsque les consignes portées sont respectées, tant lors de l'installation que durant l'utilisation de l'appareil.

ES ATENCIÓN:

La seguridad del aparato está garantizada sólo si se respetan estas instrucciones durante la fase de instalación y de empleo.

- IT** garanzia
GB warranty
DE garantie
FR garantie
ES garantía

- IT** La presente garanzia è valida 24 mesi se timbrata e datata dal rivenditore autorizzato Viabizzuno. Il periodo di garanzia è di 2 anni a partire dalla data della timbratura e decade in caso di uso improprio, manomissione o cancellatura della data, perdita o illeggibilità del presente libretto di istruzioni.
- GB** The warranty covers 24 months if stamped and dated by the authorised Viabizzuno dealer. The 24 months warranty shall no apply in case of wrong use, altered or deleted date, or if this instructions booklet gets lost or becomes unreadable.
- DE** Die Garantie gilt 24 Monate nur, wenn sie von dem zugelassenen Verkäufer Viabizzuno gestempelt wird. Die Garantie gilt 2 Jahr seit dem Stempeldatum und verfällt bei unberechtigten Gebrauch, Manipulation des Datums, Verlust oder Unlesbarkeit von den Gebrauchsanweisungen.
- FR** La durée de la garantie est de 24 mois si elle est marquée par le distributeur autorisé Viabizzuno. La garantie est valable 2 ans depuis le jour où elle a été marquée et échoit en cas d'usage impropre, alteration ou effacement de la date, e si le carnet d'instructions est perdu ou est indéchiffrable.
- ES** Esta garantía es válida por 24 meses sólo si está datada y sellada por el revendedor autorizado Viabizzuno. El período de garantía es de 2 años a partir de la fecha del sello, y decae en caso de empleo impropio, alteración o borrado de la fecha, pérdida o ilegibilidad del presente manual de instrucciones

- IT** *Viabizzuno* si riserva il diritto di apportare ai propri modelli, senza nessun preavviso, qualsiasi modifica ritenga opportuna. le nostre idee e i nostri apparecchi sono depositati e coperti da brevetti internazionali. uomo avvisato, mezzo salvato.
- GB** *Viabizzuno* reserves the right to introduce any changes to its own models, without prior notice. our ideas and our lighting fittings are registered and covered by international patents. forewarned is forearmed.
- DE** *Viabizzuno* bahält sich das Recht vor jederzeit und ohne Ankündigung die technischen Daten der im Katalog abgebildeten Produkte zu ändern. unsere Ideen und unsere Beleuchtungskörper sind eingetragen und international patentiert. wer gewarnt ist, ist halb gerettet
- FR** *Viabizzuno* se réserve le droit d'apporter une quelconque modification aux produits sans préavis. nos idées et nos corps d'illumination sont déposés et couverts de brevets internationales. un homme averti en vaut deux.
- ES** *Viabizzuno* se reserva el derecho de aportar a sus modelos, sin ningún preaviso, cualquier modificación que considere oportuna. nuestros diseños y nuestros aparatos están todos provistos y cubiertos por patentes internacionales. el que avisa no es traidor.



13x8	24Vdc	AG	IP20	CE
F6.204.01	led bianco 3000K white led 3000K Weiße LED 3000K led blanche 3000K led blanco 3000K	led	1,6W	110mm
F6.204.02	led bianco 3000K	led	3,2W	210mm
F6.204.03	led bianco 3000K	led	4,8W	310mm
F6.204.04	led bianco 3000K	led	6,4W	410mm
F6.204.05	led bianco 3000K	led	8W	510mm
F6.204.06	led bianco 3000K	led	9,6W	610mm
F6.204.07	led bianco 3000K	led	11,2W	710mm
F6.204.08	led bianco 3000K	led	12,8W	810mm
F6.204.09	led bianco 3000K	led	14,4W	910mm
F6.204.10	led bianco 3000K	led	16W	1010mm
F6.204.11	led bianco 3000K	led	17,6W	1110mm
F6.204.12	led bianco 3000K	led	19,2W	1210mm
F6.204.13	led bianco 3000K	led	20,8W	1310mm
F6.204.14	led bianco 3000K	led	22,4W	1410mm
F6.204.15	led bianco 3000K	led	24W	1510mm
F6.204.16	led bianco 3000K	led	25,6W	1610mm
F6.204.17	led bianco 3000K	led	27,2W	1710mm
F6.204.18	led bianco 3000K	led	28,8W	1810mm
F6.204.19	led bianco 3000K	led	30,4W	1910mm
F6.204.20	led bianco 3000K	led	32W	2010mm
F6.204.21	led bianco 3000K	led	33,6W	2110mm

n. 2 connettori m/f

n. 2 m/f connectors

n. 2 Verbindern AG/IG

n. 2 conectores macho/hembra

n. 2 connecteurs m/f



13x8	24Vdc			
F6.204.31	led bianco 3000K white led 3000K Weiße LED 3000K led blanche 3000K led blanco 3000K	led	1,6W	110mm
F6.204.32	led bianco 3000K	led	3,2W	210mm
F6.204.33	led bianco 3000K	led	4,8W	310mm
F6.204.34	led bianco 3000K	led	6,4W	410mm
F6.204.35	led bianco 3000K	led	8W	510mm
F6.204.36	led bianco 3000K	led	9,6W	610mm
F6.204.37	led bianco 3000K	led	11,2W	710mm
F6.204.38	led bianco 3000K	led	12,8W	810mm
F6.204.39	led bianco 3000K	led	14,4W	910mm
F6.204.40	led bianco 3000K	led	16W	1010mm
F6.204.41	led bianco 3000K	led	17,6W	1110mm
F6.204.42	led bianco 3000K	led	19,2W	1210mm
F6.204.43	led bianco 3000K	led	20,8W	1310mm
F6.204.44	led bianco 3000K	led	22,4W	1410mm
F6.204.45	led bianco 3000K	led	24W	1510mm
F6.204.46	led bianco 3000K	led	25,6W	1610mm
F6.204.47	led bianco 3000K	led	27,2W	1710mm
F6.204.48	led bianco 3000K	led	28,8W	1810mm
F6.204.49	led bianco 3000K	led	30,4W	1910mm
F6.204.50	led bianco 3000K	led	32W	2010mm
F6.204.51	led bianco 3000K	led	33,6W	2110mm

n. 1 connettore maschio
n. 1 male connector
n.1 männlich Verbindern
n.1 connecteur mâle
n.1 conector masculino



- F9.204.91** cavo 2x0,35 2000mm
 cable 2x0,35
 Kabel 2x0,35
 câble 2x0,35
 cable 2x0,35

n. 2 connettori m/f amp2
n. 2 m/f connectors
n. 2 Verbinder AG/IG amp2
n. 2 connecteurs m/f amp2
n. 2 conectores macho/hembra amp2



- F9.204.90** cavo 2x0,35 1500mm
 cable 2x0,35
 Kabel 2x0,35
 câble 2x0,35
 cable 2x0,35

n. 1 connettore femmina
n. 1 female connector
n. 1 weiblich Verbinder
n.1 connecteur femelle
n. 1 conector hembra

**alimentatori
 control gears**

120-240V 0-50-60Hz ECG IP20 U_{CE}

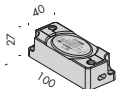

- T4.415** alimentatore led tensione costante 24Vdc 10W
 costant voltage led power supply 24Vdc
 Led-Netzteil für Gleichspannung 24Vdc
 alimentateur led tension constante 24Vdc
 alimentador led de tensión constante 24Vdc

240V 50-60Hz ECG IP20 U_{CE}

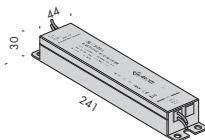

- T4.010.1** alimentatore led tensione costante 24Vdc 75W
 costant voltage led power supply 24Vdc
 Led-Netzteil für Gleichspannung 24Vdc
 alimentateur led tension constante 24Vdc
 alimentador led de tensión constante 24Vdc

legenda
key
Legende
légende
clave de lectura

- 1** 13X8 n. 1 connettore maschio
13X8 n. 1 male connector
13X8 n. 1 männlich Verbindern
13X8 n. 1 connecteur mâle
13X8 n. 1 conector masculino
- 2** 13X8 n. 2 connettori m/f
13X8 n. 2 m/f connectors
13X8 n. 2 Verbindern AG/IG
13X8 n. 2 connecteurs m/f
13X8 n. n. 2 conectores macho/hembra
- 3** tappo di chiusura incluso
end cap included
einschl. Verschlusskappe
bouchon de fermeture inclus
tapa de cierre incluida
- 4** F9.204.91 cavo l. 2000mm n. 2 connettori m/f amp2
F9.204.91 cavo l. 2000mm n. 2 m/f connectors
F9.204.91 Kabel l. 2000mm n. 2 Verbindern AG/IG amp2
F9.204.91 câble l. 2000mm n. 2 connecteurs m/f amp2
F9.204.91 cable l. 2000mm n. 2 conectores macho/hembra amp2
- 5** F9.204.90 cavo l. 150mm n. 1 connettore femmina
F9.204.90 cavo l. 150mm n. 1 female connector
F9.204.90 Kabel l. 150mm n. 1 weiblich Verbindern
F9.204.90 câble l. 150mm n. 1 connecteur femelle
F9.204.90 cable l. 150mm n. 1 conector hembra

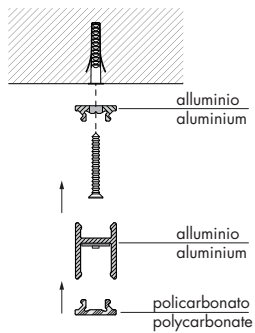
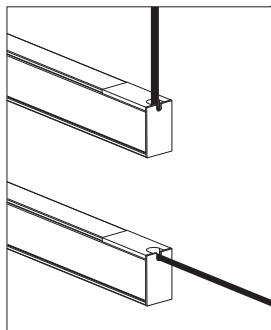
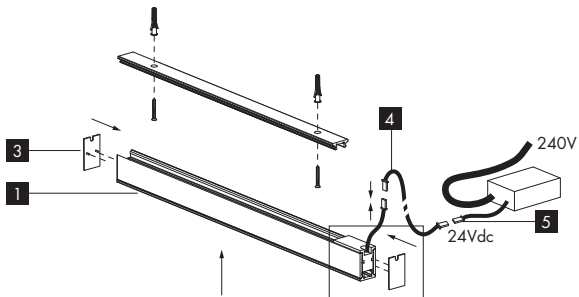

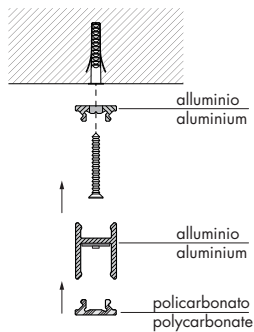
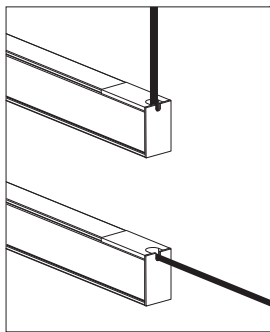
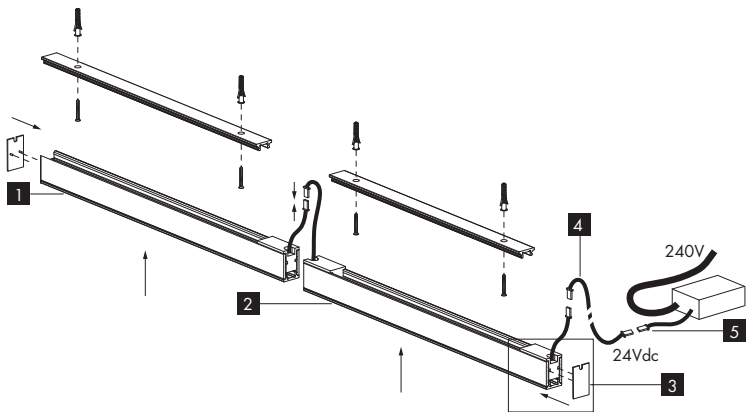

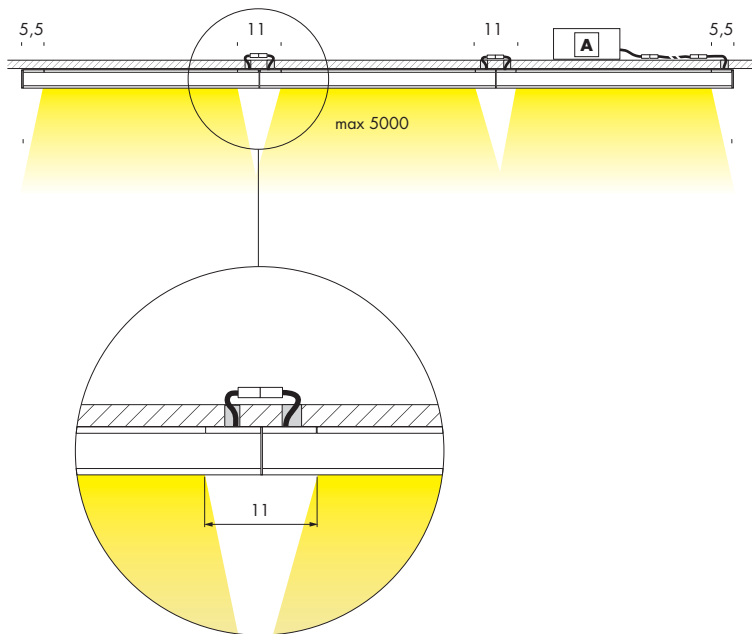

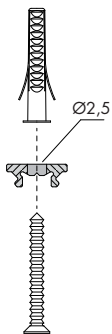

F6.204.01/31



F6.204.02/32

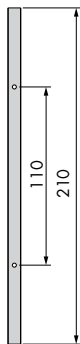

F6.204.03/33

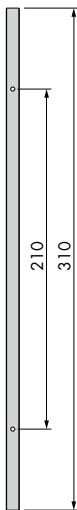

F6.204.04/34

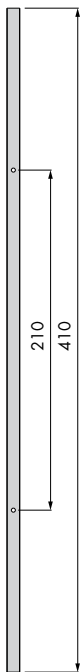

F6.204.05/35

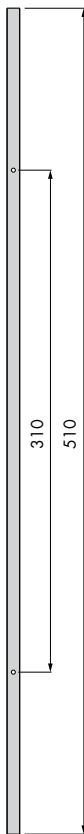

F6.204.06/36

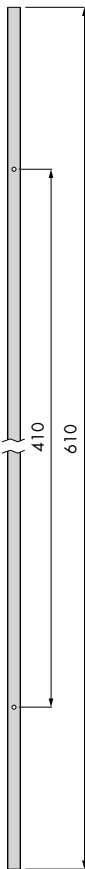

F6.204.07/37

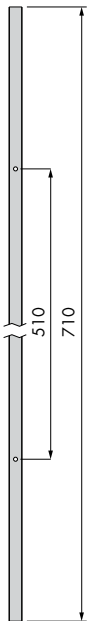

F6.204.08/38

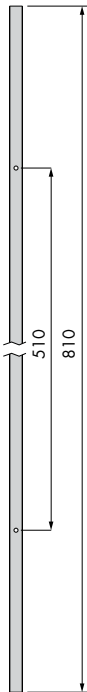

F6.204.09/39

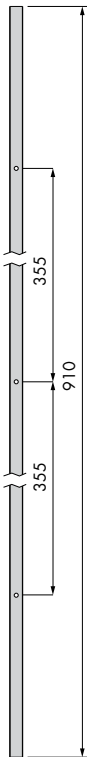

F6.204.10/40

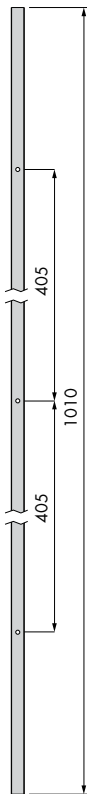

F6.204.11/41

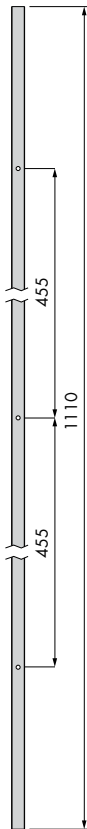

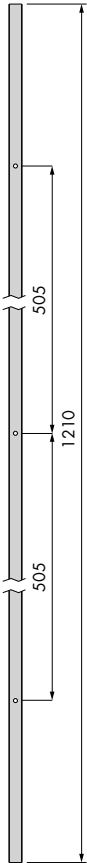
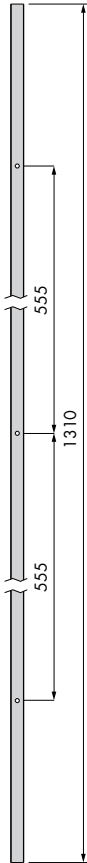
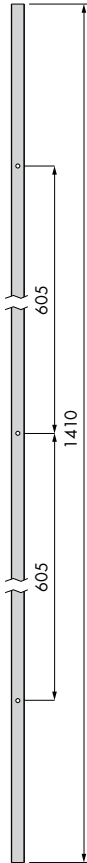
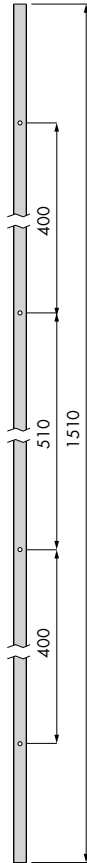
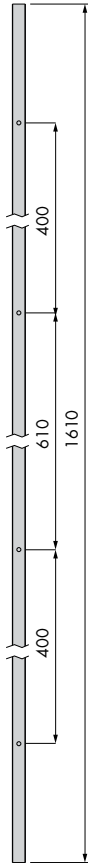
F6.204.12/42**F6.204.13/43****F6.204.14/44****F6.204.15/45****F6.204.16/46**

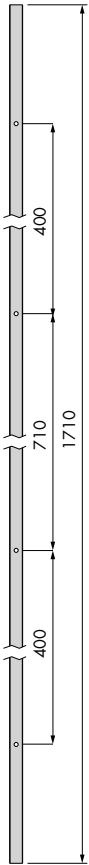
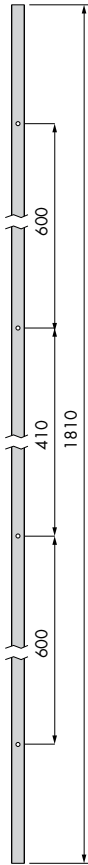
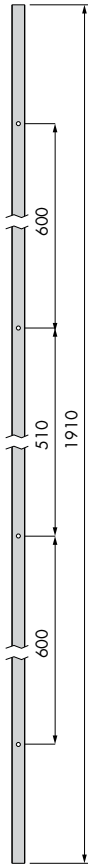
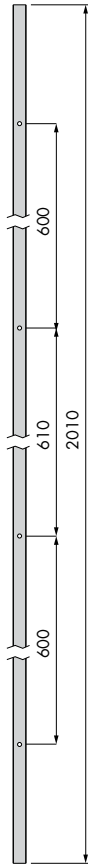
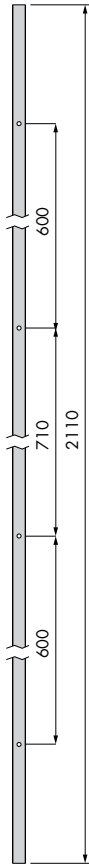
F6.204.17/47**F6.204.18/48****F6.204.19/49****F6.204.20/50****F6.204.21/51**



IT smaltimento dell'apparecchio

GB equipment disposal

DE entsorgung des geräts

FR élimination de l'appareil

ES eliminación del aparato

IT A fine vita l'apparecchio di illuminazione un rifiuto che rientra nella categoria Raee (Rifiuto di Apparecchiatura Elettrica ed Elettronica), pertanto non deve essere smaltito come un rifiuto municipale misto ma deve essere smaltito correttamente per evitare danni all'ambiente, alle persone e agli animali, ed evitare lo spreco di materiali riciclabili. E' possibile consegnare il vecchio apparecchio al venditore nel momento in cui si acquista un nuovo apparecchio di illuminazione, oppure portare l'apparecchio nelle aree pubbliche di raccolta predisposte dalle amministrazioni comunali, o depositarlo negli appositi contenitori.

GB At the end of its life cycle, the light fixture should be considered as a Weee (Waste of electrical and electronic equipment) category waste, therefore it should be disposed of not as generic municipal waste, but properly in order to avoid damages to the environment, people and animals, and to avoid any waste of recyclable materials. When ordering a new light fixture, the customer may give back his/her old one to the seller, or bring it to the public collection sites arranged by the municipal authorities, or simply put it in special collection containers.

DE Am Ende der Lebensdauer ist das Gerät als Elektro- und Elektronik-Altgerät (ElektroG) zu behandeln und darf daher nicht zum Restmüll gegeben, sondern muss korrekt entsorgt werden, um die Schädigung von Umwelt, Personen und Tieren sowie die Verschwendung recycelbarer Materialien zu vermeiden. Das ausgediente Gerät kann beim Kauf eines neuen Gerätes beim Händler abgegeben oder zu einer öffentlichen Sammelstelle gebracht bzw. in den dafür vorgesehenen Behältern deponiert werden.

FR A la fin de sa durée de vie, l'appareil d'éclairage est un déchet qui entre dans la catégorie DEEE (Déchets des Equipements Electriques et Electroniques) ; il ne doit donc pas être éliminé comme un déchet municipal mixte mais correctement pour éviter tout dommage à l'environnement, aux personnes et aux animaux, et éviter le gaspillage de matériaux recyclables. Il est possible de remettre le vieil appareil au vendeur lorsque l'on achète un nouvel appareil d'éclairage, ou de porter l'appareil dans les aires publiques de collecte prévues par les administrations communales, ou de le déposer dans les contenants prévus à cet effet.

ES Al final de su vida, el aparato de iluminación es un residuo que está incluido en la categoría Raee (Residuo de aparatos eléctricos y electrónicos), por lo tanto no tiene que eliminarse como un residuo urbano mixto, sino que tiene que eliminarse de forma correcta para evitar daños al medio ambiente, a las personas y los animales, y para evitar el derroche de materiales reciclables. Es posible entregar el aparato antiguo al vendedor en el momento en que se compre un aparato de iluminación nuevo, o bien llevar el aparato a la zona pública de recogida preparadas por las administraciones municipales, o depositarlo en los contenedores al efecto.

- IT** indice marcature
GB marking index
DE Kennzeichenverzeichnis
FR index de marquage
ES indice de marcado



- IT** classe 3 (alimentazione effettuata con bassissima tensione di sicurezza; sono escluse tensioni superiori a 50 V- 50Hz. Messa a terra non prevista).
GB class 3 (very low safety supply tension; not to be used over 50V-50Hz. Earthing excluded).
DE Klasse 3 (Versorgung mit Niederspannung. Spannung Höher als 50v-50 Hz.sind völlig ausgeschlossen. Schutzerdung nicht vorgeschrieben).
FR class 3 (alimentation de sécurité à basse tension. ne doit en aucun cas être utilisée pour des tensions supérieures à 50V-50Hz. Mise à la terre: excluse).
ES Clase 3 (alimentación realizada con voltaje bajísimo de seguridad; voltajes superiores a 50V-50Hz quedan excluidos. Puesta a tierra no prevista).



- IT** Apparecchi idonei al montaggio diretto su superfici normalmente infiammabili
GB Luminaries suitable for direct mounting on flammable surfaces
DE Geeignet fuer direkt Einbau auf entzuenlichen Oberflaechen
FR Appareil predisposé à un montage direct sur une superficie normalment inflammable
ES Aparatos adecuados para el montaje directo sobre superficies normalmente inflamables

- IP20 IT** Apparecchio ordinario
GB Ordinary
DE Normales Gerät
FR Appareil ordinaire
ES Aparato normal



- IT** Alimentatore escluso
GB Control gear not included
DE Vorhaltgerät nicht mitgeliefert
FR Sans platine d'alimentation
ES Alimentador excluido



- IT** prodotto conforme alle direttive europee
GB produced in compliance with EC directives
DE Gebaut gemaeß EG-Vorschriften
FR produit conforme aux Directives de la Communauté Européenne
ES Producto conforme con las directivas europeas

Viabizzuno strada principale della frazione Bizzuno in provincia di ravenna dove tra la casa del popolo e la parrocchia, al n°17, sono nato il ventuno luglio millenovecentocinquantacinque.

mn

Viabizzuno raccoglie attorno a sé esperienza, conoscenza e ricerca per poter meglio esprimere il proprio 'modo di fare luce'. il pensiero progettuale di Viabizzuno si identifica in una pagina bianca. due linee di prodotti complementari occupano questo spazio esplorandolo, dilatandolo: si incrociano forti della propria identità, due anime rappresentate dalle collezioni For m e Alvaline. inoltre sviluppa e realizza apparecchi di illuminazione speciali e su misura. è fondamentale che il progetto sia stimolante e che l' interlocutore sia preparato a una progettazione complessa, che richiede tempo e impegno. progettiamo la luce a 360°.

Viabizzuno is the name of the main road of the small village Bizzuno, located in the province of ravenna, where I was born on the 21st of july 1955 at n°17, between the "casa del popolo" and the local parish church.

mn

Viabizzuno channels together experience, knowledge and research to express its "way of making light" as best as possible. Viabizzuno planning concepts are exalted when posed before a blank page; two complementary product lines occupy the space by exploring it and expanding it. they entwine together without vanishing thanks to their clear-cut identity. distinct yet complementary just like the two souls represented by the two Viabizzuno collections For m and Alvaline. it designs and produces special and custom-made lighting equipment too. it is essential that the project is stimulating and that the other party is prepared for a complex design process, requiring time and commitment. we design ligh at 360°.



**energia pulita
clean energy**



For m divide lo spazio verticalmente: equilibrata, razionale, rigorosa. il corpo illuminante evolve nella sua funzione di fare luce:

il suo uso é sempre più flessibile e la sua capacità di fondersi con l'architettura ne fa un vero materiale da costruzione, attraverso un design non invasivo, non mimetico, non sfacciatamente decorativo.

i corpi illuminanti si ritraggono nelle pareti, a filo intonaco, a scomparsa, nascosti alla vista lasciando piena soggettività alla luce. il grigio dei materiali come cemento, alluminio, acciaio é il colore della collezione For m.

For m divides space vertically. it is balanced, rational and rigorous. the lighting element is an evolution in the way that light is shed: its way of being used becomes evermore flexible and its capacity of blending with the surrounding architecture makes it a true building material, thanks to its non-intrusive yet non-mimetic design, which is not brazenly decorative. the recessed lighting elements retract into the wall, grazing against the plaster to hide away from sight and leave the whole scene to the light. the gray of materials like cement, aluminium, and steel is the colour of the For m collection.

manuale For m 2007
manual For m 2007



italiano
cod.19091



english
français
русский язык
cod.19092



english
español
deutsch
cod.19093

cartella colori e finiture
folder sample finishes
and colours



cod. 19941

libro For m
book For m

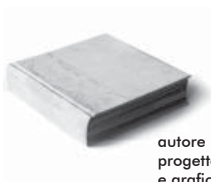

autore mario nanni
progetto editoriale
e grafico Viabizzuno
edito da Viabizzunoeditore
seconda edizione
author mario nanni
Viabizzuno publishing
and graphics project edited
by Viabizzunoeditore
second edition
cod. 15248

Avaline attraversa lo spazio diagonalmente: dinamica, irriverente, ironica, giocosa. inizia il gesto, dove si muovono gli sguardi, dove la materia si fonde mescolandosi alla luce, si originano così colore e forma, che vivono per se stesse e per l'emozione che li circonda. il blu della notte é il suo colore.

Avaline cuts through space diagonally with dynamism, irreverence, irony and playfulness. its gesture is marked by the shifting of glances, by the blending of matter with light thus giving life to colour and form which live a life of their own with the emotions surrounding them. midnight blue is its colour.



italiano
cod.16162-2



english
français
русский язык
cod.16164-2



english
español
deutsch
cod.16166-2



cod. 19941

cartella colori e finiture
folder sample finishes
and colours

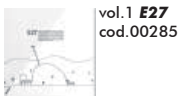

vol.1 **E27**
cod.00285



vol.2 **h2o**
cod.00283



vol.3 **bamboo**
cod.00289



vol.4 **alva1**
cod.00291

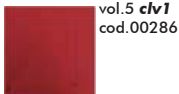

vol.5 **clv1**
cod.00286

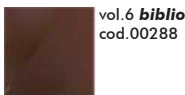

vol.6 **biblio**
cod.00288



vol.7 **mon amour**
cod.00282



vol.8 **emma**
cod.00287



vol.9 **clv2**
cod.00284

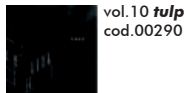

vol.10 **tulp**
cod.00290



vol.11 **fileau**
cod.14564



vol.13 **UpOGalleggio**
cod.15215



vol.14 **steelon**
cod.17904



vol.18 **toccamì**
cod.17777



vol.19 **la DOdò**
cod.17779

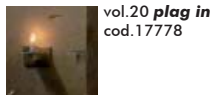

vol.20 **plag in**
cod.17778

Viabizzuno srl

10 via romagnoli
40010 bentivoglio
bologna italia

t+39 0518908011

f+390518908089

www.viabizzuno.com

viabizzuno@viabizzuno.com