

# Contents

# Sony Ericsson K608i T-Mobile

## **Getting started** ..... 5

Assemble the phone, SIM card, battery, make a call.

## **Getting to know your phone** ..... 9

Phone overview, use the menus, enter letters, t-zones, activity menu, file manager.

## **Calling** ..... 19

Calls, video calls, contacts, voice control, call options.

## **Messaging** ..... 38

Text messaging, picture messaging, voice messaging, email.

## **Imaging** ..... 47

Camera, video recorder, pictures, PhotoDJ™.

## **Entertainment** ..... 52

Media player, radio, ringtones, MusicDJ™, VideoDJ™, sound recorder, themes, games.

## **Connectivity** ..... 61

Internet and email settings, browsing, synchronizing, Bluetooth, infrared, USB cable.

## **More features** ..... 71

Time and date, alarm clock, calendar, tasks, Java™ applications, SIM card lock, etc.

## **Troubleshooting** ..... 80

Why doesn't the phone work the way I want?

## **Additional information** ..... 85

Sony Ericsson Consumer Web site, safe and efficient use, warranty, declaration of conformity.

## **Icons** ..... 93

Icon descriptions

## **Index** ..... 95

## Sony Ericsson

UMTS-GSM 900/1800/1900

First edition (May 2005)

This user guide is published by Sony Ericsson Mobile Communications AB, without any warranty.

Improvements and changes to this user guide necessitated by typographical errors, inaccuracies of current information, or improvements to programs and/or equipment, may be made by Sony Ericsson Mobile Communications AB at any time and without notice. Such changes will, however, be incorporated into new editions of this user guide.

All rights reserved.

©Sony Ericsson Mobile Communications AB,  
2005

Publication number: EN/LZT 108 7916 R1A

Please note:

Some of the services in this user guide are not supported by all networks. *This also applies to the GSM International Emergency Number 112.*

Please contact your network operator or service provider if you are in doubt whether you can use a particular service or not.

Please read the *Guidelines for safe and efficient use* and the *Limited warranty* chapters before you use your mobile phone.

Your mobile phone has the capability to download, store and forward additional content, e.g. ringtones. The use of such content may be restricted or prohibited by rights of third parties, including but not limited to restriction under applicable copyright laws. You, and not Sony Ericsson, are entirely responsible for additional content that you download to or forward from your mobile phone. Prior to your use of any additional content, please verify that your intended use is properly licensed or is otherwise authorized. Sony Ericsson does not guarantee the accuracy, integrity or quality of any additional content or any other third party content. Under no circumstances will Sony Ericsson be liable in any way for your improper use of additional content or other third party content.

The Bluetooth word mark and logos are owned by the Bluetooth SIG, Inc. and any use of such marks by Sony Ericsson is under license.

3GPP is a trademark of ETSI in France and other jurisdictions.

MusicDJ™, PhotoDJ™ and VideoDJ™ are trademarks or registered trademarks of Sony Ericsson Mobile Communications AB.

Real is a trademark or a registered trademark of RealNetworks, Inc.

Microsoft, Windows and PowerPoint are either registered trademarks or trademarks of Microsoft Corporation in the U.S and other countries.

Mac OS is a trademark of Apple Computer, Inc., registered in the U.S. and other countries.

T9™ Text Input is a trademark or a registered trademark of Tegic Communications.

T9™ Text Input is licensed under one or more of the following: U.S. Pat. Nos. 5,818,437, 5,953,541, 5,187,480, 5,945,928, and 6,011,554; Canadian Pat. No. 1,331,057, United Kingdom Pat. No. 2238414B; Hong Kong Standard Pat. No. HK0940329; Republic of Singapore Pat. No. 51383; Euro.Pat. No. 0 842 463(96927260.8) DE/DK, FI, FR, IT, NL, PT, ES, SE, GB; and additional patents are pending worldwide.

Java and all Java based trademarks and logos are trademarks or registered trademarks of Sun Microsystems, Inc. in the U.S. and other countries.

End-user license agreement for Sun™ Java™ J2ME™.

- 1** Restrictions: Software is confidential copyrighted information of Sun and title to all copies is retained by Sun and/or its licensors. Customer shall not modify, decompile, disassemble, decrypt, extract, or otherwise reverse engineer Software. Software may not be leased, assigned, or sublicensed, in whole or in part.
- 2** Export Regulations: Software, including technical data, is subject to U.S. export control laws, including the U.S. Export Administration Act and its associated regulations, and may be subject to

export or import regulations in other countries. Customer agrees to comply strictly with all such regulations and acknowledges that it has the responsibility to obtain licenses to export, re-export, or import Software. Software may not be downloaded, or otherwise exported or re-exported (i) into, or to a national or resident of, Cuba, Iraq, Iran, North Korea, Libya, Sudan, Syria (as such listing may be revised from time to time) or any country to which the U.S. has embargoed goods; or (ii) to anyone on the U.S. Treasury Department's list of Specially Designated Nations or the U.S. Commerce Department's Table of Denial Orders.

- 3** Restricted Rights: Use, duplication or disclosure by the United States government is subject to the restrictions as set forth in the Rights in Technical Data and Computer Software Clauses in DFARS 252.227-7013(c) (1) (ii) and FAR 52.227-19(c) (2) as applicable.

Part of the software in this product is copyright © SyncML initiative Ltd. (1999-2002). All rights reserved.

Contains Macromedia® Flash™ technology by Macromedia, Inc. Copyright © 1995-2003 Macromedia, Inc. All rights reserved.

Macromedia, Flash, Macromedia Flash, and Macromedia Flash Lite are trademarks or registered

trademarks of Macromedia, Inc. in the United States and other countries.

Other product and company names mentioned herein may be the trademarks of their respective owners.

Any rights not expressly granted herein are reserved.

## Getting started

*Assemble the phone, SIM card, battery, make a call.*

More information and downloads are available at [www.SonyEricsson.com/support](http://www.SonyEricsson.com/support).

### Instruction symbols

The following instruction symbols appear in this user guide:



Note



Indicates that a service or function is network- or subscription-dependent. Contact your network operator for details.



See also page ...



Use the selection keys or the navigation key to scroll and select, ➡ *12 Keys and navigation*.



Press the navigation key centre.



Press the navigation key up.



Press the navigation key down.



Press the navigation key to the left.



Press the navigation key to the right.

### Assembling the phone

Before you can use your phone you need to:

- Insert the SIM card.
- Attach and charge the battery.

### SIM card

When you register as a subscriber with a network operator, you get a SIM (Subscriber Identity Module) card. The SIM card contains a computer chip that keeps track of your phone number, the services included in your subscription, and names and numbers in your contacts, among other things.



*If you have been using a SIM card in another phone, make sure that your information is saved to the SIM card before you remove it from the other phone. For example, contacts may have been saved in the phone memory.*

## Getting started

### SIM card and battery information

Always turn off the phone and detach the charger before you insert or remove a SIM card.

 It may take up to 30 minutes before the battery icon appears when charging.

### To insert SIM card and battery

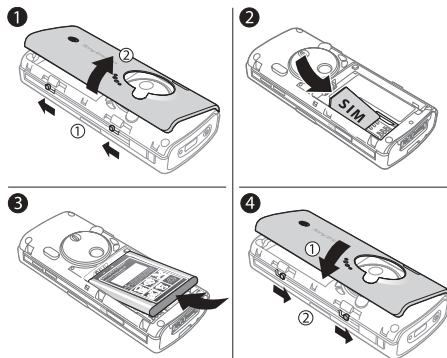

- 1 Remove the battery cover by sliding the two catches on the side of the phone and lifting it away as shown in the picture.
- 2 Slide the SIM card into its holder. Make sure that the gold contacts of the SIM card are facing down, and the cut off corner is correctly aligned.
- 3 Place the battery on the back of the phone with the label side up and the connectors facing each other.

- Place the battery cover as shown in the picture and slide the two catches back into place.

### To charge the battery

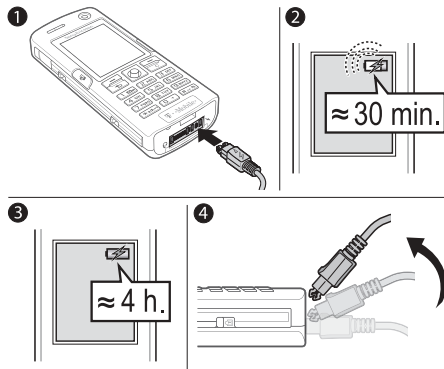

- Connect the charger to the phone. The symbol on the charger plug must face upwards.
- It may take up to 30 minutes before the battery icon appears on the screen.

- It takes approximately 2 hours until the battery icon indicates that the battery is fully charged. If you do not see the battery icon after this time, press a key to activate the screen.
- Remove the charger by tilting the plug upwards.

### PIN (Personal Identification Number)

You may need a PIN (Personal Identification Number) to activate the services in your phone. The PIN is associated with your SIM card, and not with the phone. Your PIN is provided by your network operator. When you enter your PIN, each digit appears as \*, unless your PIN starts with the same digits as an emergency number, for example 112. This is so that you can see and call an emergency number without entering a PIN.

If you make a mistake while entering your PIN, delete the number by pressing **(C)**.



*If you enter the wrong PIN three times in a row, the SIM card is blocked and the message PIN blocked appears. To unblock it, you need to enter your PUK (Personal Unblocking Key), ➤ 77 SIM card lock.*

## Getting started

### Turning on the phone and making calls

Make sure that the phone is charged and your SIM card is inserted before you turn it on. When you have turned the phone on, you can use the setup wizard to quickly and easily prepare your phone for use.

#### To turn on the phone



- 1 Press and hold .
- 2 Enter your SIM card PIN, if requested.
- 3 At first start-up, select the language you want for your phone menus.

- 4 ▶ **Yes** if you want the setup wizard to help you get started, and follow the instructions that appear. You can start the wizard from the menu system at any time, ▶ **Settings** ▶ the **General** tab ▶ **Setup wizard**.

#### To make and receive calls

Enter the phone number (with international prefix and area code if applicable) ▶ **Call** to make the call, or press and hold  to make a video call.  
▶ **End call** to end the call. When the phone rings  
▶ **Answer**.









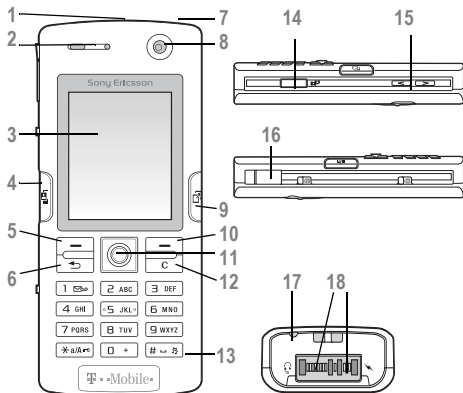



## Getting to know your phone

Phone overview, use the menus, enter letters, t-zones, activity menu, file manager.

### Phone overview



- |       |   |
|-------|---|
| 1     | Infrared port   |
| 2     | Ear speaker   |
| 3     | Screen  |
| 4     |  Video call key              |
| 5, 10 |  Selection keys              |
| 6     |  Back key                    |
| 7     |  Power on/off button         |
| 8     | Video call camera   |
| 9     |  Activity menu               |
| 11    |  Navigation key              |
| 12    |  Clear key                   |
| 13    |  Silent key                  |
| 14    |  Camera button               |
| 15    |  Camera zoom, volume buttons |
| 16    | USB port  |
| 17    | Microphone  |
| 18    | Stereo headset and charger connector  |

For more information on keys and navigation,  
 ➤ *12 Keys and navigation.*

## Getting to know your phone



### t-music\*



### t-zones\*



### File manager

- Pictures
- Videos
- Sounds
- Themes
- Web pages
- Games
- Applications
- Other



### Entertainment

- Media Player
- Radio
- Games
- VideoDJ™
- PhotoDJ™
- MusicDJ™
- Remote control
- Record sound
- Demo tour



### Messages

- Write new
- Inbox
- Email
- Call voicemail
- Drafts
- Outbox
- Sent messages
- Saved messages
- Templates
- Settings



### Camera



### SIM Application Toolkit (SAT)/Radio\*



### Contacts

- Contacts\*\*
- Options:
  - Speed dial
  - My business card
  - Groups\*\*
  - SIM contacts\*\*
  - Special numbers
  - Advanced
  - New contact



### Video call



### Calls



All



Answered



Dialled



Missed



### Organizer

- Alarms
- Applications
- Calendar
- Tasks
- Notes
- Synchronization
- Timer
- Stopwatch
- Light
- Calculator
- Code memo



### Settings



#### General

- Profiles
- Time & date
- Language
- Voice control
- New events
- Phone status
- Shortcuts
- Start-up menu
- Locks
- Setup wizard
- Tips and tricks
- Master reset



#### Sounds & alerts

- Ring volume
- Ringtone
- Silent mode
- Increasing ring
- Vibrating alert
- Message alert
- Key sound



#### Display

- Wallpaper
- Themes
- Start-up screen
- Screen saver
- Brightness
- Sleep mode clock
- Edit line names\*



#### Calls

- Divert calls
- Switch to line 2\*
- Manage calls
- Time & cost
- Show or hide no.
- Handsfree



#### Connectivity

- Bluetooth
- Infrared port
- Synchronization
- Device mgmt.
- Mobile networks
- Data comm.
- Internet settings
- Streaming settings
- Settings for Java™
- Accessories

\* Please note that some menus are operator-, network- and subscription-dependent.

\*The menu depends on which contacts application is selected as default.

\*\*\* Only available if SAT is not available. SAT is a SIM-card dependent service.

### Keys and navigation

#### Standby screen and main menu and status bar







The *standby screen* is displayed when you are not calling or using the menus. This is where you can see, for example, the name of your operator, the time and the date.

From standby, press  to enter the *main menu*, where the menus are shown as icons. Some submenus include tabs. Scroll to a tab using the navigation key and select an option. To get more information, explanations or tips about selected features, menus or functions available in your phone, scroll to a menu item ► **Info**. To enter a list of options ► **More**. There are different alternatives in the list of options depending on where you are in the menus.

The status bar at the top of the screen contains icons, which give information related to the phone and its activities, ► **93 Icons**.







### Keys and buttons

---

	Press to enter the main menu from standby. Press to select highlighted items. During a call, press to view a list of options.
	Move through menus and tabs.
	Press to select the options shown immediately above these keys on the screen.
	Press to go back one level in the menus. Press and hold to return to standby or end a function.
	Press to delete items, such as pictures, sounds and contacts. During a call, press and hold to mute the microphone.
	Press and hold to make a video call or to enter video call mode.

---

---

	Press and hold to open the activity menu, ➤ <i>17 Activity menu.</i>
	Press to take a picture or to record a video clip.
	Press and hold to call your voicemail service (if set).
 - 	Press and hold any of these keys to reach a contact beginning with a specific letter.
 - 	Press any of these keys and press <b>Call</b> to speed dial.

---

---

	In standby, press to view status information. To reject a call, quickly press twice when receiving a call. Press once to turn off the ringtone when receiving a call. During a call, press to increase the volume. When using the media player (also when minimized), press to increase the volume. Press and hold to go back one track. When using the camera, press to zoom in. Press and hold to voice dial, alternatively say your magic word (if set), ➤ <i>29 Voice dialling.</i>
---	---

---

## Getting to know your phone



In standby, press to view status information.  
To reject a call, quickly press twice when receiving a call.  
Press once to turn off the ringtone when receiving a call.  
During a call, press to decrease the volume.  
When using the media player (also when minimized), press to decrease the volume. Press and hold to go forward one track.  
When using the camera, press to zoom out.



When using the camera, press to turn on the photo light.



Press and hold to set the phone to silent. Press once to turn off the ringtone when receiving a call.

---

### Phone language

Most SIM cards automatically set the language used in the menu to the language of the country where you bought your SIM card. If this is not the case, the predefined language is English.



*You can always choose language according to SIM by pressing 8888 in standby.*

*You can always choose English by pressing 0000 in standby.*

### To change the phone language

- ▶ Settings ▶ the General tab ▶ Language ▶ Phone language.
- Select a language.

### Shortcuts

A quicker way to move through the menus is to use shortcuts. You can use keypad shortcuts to quickly go to a menu, and you can use predefined navigation key shortcuts to quickly reach certain functions. You can edit the navigation key shortcuts to suit your own needs.

### Using keypad shortcuts

Enter the menus by pressing and then enter the number of the menu to which you want to go. For example, to reach the fifth menu item, press . To reach the tenth, eleventh and twelfth menu items, press , and respectively. To go back to standby, press and hold .

## Using navigation key shortcuts

In standby, press , , or to go directly to a function. The first time you press , you can choose the function you want to use as a shortcut.

### To edit a navigation key shortcut

► Settings ► the General tab ► Shortcuts and select which shortcut you want to edit ► Edit. Press if you want to delete the shortcut.

## Entering letters

There are two ways of entering letters, for example, when writing a message or writing a name in contacts:

- Multitap text input

You press each key as many times as needed to show the letter you want.

- T9™ Text Input

The T9 Text Input method uses a built-in dictionary to recognize the most commonly used word for each sequence of key presses. This way, you press each key only once, even if the letter you want is not the first letter on the key.

## Writing languages

Before you start entering letters, you need to select the languages that you want to use when writing.

When writing, you can switch to one of your selected languages by pressing and holding .

### To select writing language

- 1 ► Settings ► the General tab ► Language ► Writing language.
- 2 Scroll to each language that you want to use and mark it. ► Save to exit the menu.





### To enter letters using multitap text input

- 1 To enter text, you have to be in a function where text input is possible, for example ► Messaging ► Write new ► Text message.
- 2 Press the appropriate key, – , or , repeatedly until the character you want appears on the screen. You can see which characters you can choose in the box in the top right corner of the screen.













### Example:

- To enter an ‘A’, press once.
- To enter a ‘B’, quickly press twice.





## Getting to know your phone

- To shift between capital and lower-case letters, press , then enter the letter.
- You can use the volume buttons as a shortcut to certain letters. To enter a 'B', press and hold the  volume button and press . To enter a 'C', press and hold the  volume button and press .

### To enter letters using T9™ Text Input

- 1 To enter text, you have to be in a function where text input is possible, for example **► Messaging ► Write new ► Text message.**
- 2 For example, if you want to write the word “Jane”, press , , , .
- 3 If the word shown is the one you want, press  to accept and add a space. To accept a word without adding a space, press . If the word shown is not the one you want, press  or  to view alternative words. Accept a word and add a space by pressing .
- 4 Continue writing your message. To enter a full stop or other punctuation marks, press  and then  or  repeatedly. Accept by pressing .

### To add words to the T9 Text Input dictionary





- 1 While entering letters **► More ► Spell word.**
- 2 Edit the word by using multitap input. Navigate between the letters with  and . To delete a character, press . To delete the entire word, press and hold .
- 3 When you have edited the word **► Insert.** The word is added to the T9 Text Input dictionary. Next time you enter this word using T9 Text Input, it will appear as one of the alternative words.

### To select another writing method

Before, or while entering letters, press and hold  to select another writing method.

### Options list

Before, or while entering letters, **► More** to view a list of options. The list may contain some or all of the following:

- **Add symbol** – symbols and punctuation marks such as ? and , are shown. Move between the symbols by using , ,  and .
- **Add item** – pictures, melodies, sounds, templates and animations.



- **Spell word** – for T9 Text Input only. Edit the suggested word by using multitap text input.
- **Writing language** – a list of available languages is shown.
- **Writing method** – a list of methods available for the current language is shown.
- **Dictionary (T9)** – turn T9 Text Input dictionary on or off.
- **Word suggestions** – select to view, or not, word suggestions when writing a word.
- **My words** – manage the words that you have added to the dictionary.
- **National chars.** – turn off language-specific characters to save space. This option appears only for some writing languages.

### Activity menu

You can open the activity menu almost anywhere in the phone to view and handle new events, and access bookmarks and shortcuts.

#### **To open and close the activity menu**

Press and hold .

### Activity menu tabs

- **New events** – this shows new events such as missed calls and messages. When a new event occurs, the tab appears on the screen. Press  to dismiss or delete an event from the event tab.
- **My shortcuts** – this shows your shortcuts and applications that are running in the background. You can add, delete and change the order of shortcuts. When you select a shortcut and the application opens, other programs are closed or minimized.
- **Bookmarks** – this shows your own Internet bookmarks. When you select a bookmark and the browser opens, other programs are closed or minimized.

#### **To select a view for new events**

If you want new events to appear as pop-up text instead of in the activity menu, ► **Settings** ► the **General** tab ► **New events** ► **Pop-up**.

### File manager

Use the file manager to handle files saved in the phone memory. Items such as **Pictures**, **Videos**, **Sounds**, **Themes**, **Games**, **Applications**, and **Web pages** are saved as files in folders. All files

## Getting to know your phone

that the phone cannot recognize are saved in the **Other** folder. You can create your own subfolders in some predefined folders, to which you can move your saved files. You can also transfer the saved files to a computer, ➤ *69 File transfer using Bluetooth* and ➤ *70 The USB cable*.

### **To use a file from the file manager**

- 1 Highlight a file in the **Pictures** or **Sounds** folder.
- 2 ▶ **More** ▶ **Use as**. Select what you want to use the file for.

### **To move a file to a folder**

- 1 ▶ **File manager** and open a folder.
- 2 Scroll to a file, for example, a picture that you want to move ▶ **More** ▶ **Manage files** ▶ **Move to folder**.
- 3 Select the folder you want to move the file to, or select **New folder** and name the folder ▶ **OK**.

### **To create a subfolder**

- 1 ▶ **File manager** and open a folder.
- 2 ▶ **More** ▶ **New folder** and enter a name for the folder.
- 3 ▶ **OK** to save the folder.

### **To select several files**

- 1 ▶ **File manager** and select a file ▶ **More** ▶ **Mark** ▶ **Mark several**.
- 2 Scroll and select more files by pressing **Mark** or **Unmark**.

### **To select all files in a folder**

▶ **File manager** and select a file ▶ **More** ▶ **Mark** press **Mark all** or **Unmark all** to remove the selection.

### **To move or copy files to a computer**

➤ *69 File transfer using Bluetooth*. ➤ *70 The USB cable*.

### **File information**

Items that are downloaded, or received using one of the available transfer methods, may be copyright-protected. If a file is protected, you may not be able to copy or send that file. You can select to view information for the file.

## Calling

*Calls, video calls, contacts, voice control, call options.*



### Making calls

Before you can make or receive any calls, you must turn on the phone and be within range of a network.

➡ 8 *Turning on the phone and making calls.* To make a video call, ➡ 21 *Video call.*

### Networks

When you turn on the phone, it automatically selects your home network if this is within range. If it is not within range, you may use another network, provided your network operator has an agreement that allows you to do so. This is called roaming.



You can select the network you want to use, or you can add a network to your list of preferred networks. You can also change the order in which networks are selected during an automatic search. For all such options ▶ **Settings** ▶ the **Connectivity** tab ▶ **Mobile networks**. Use  or  to scroll between the tabs.

### To make a call

- 1 Enter the phone number (with international country code and area code if applicable).
- 2 ▶ **Call** to make a voice call, or press and hold  to make a video call. ▶ **More** to view options.
- 3 ▶ **End call** to end the call.

 *You can call numbers from your contacts and call list, ➡ 23 *Contacts*, and ➡ 27 *Call list*. You can also use your voice to make calls, ➡ 29 *Voice control*.*

### To change the ear speaker volume

Press  or  to increase or decrease the ear speaker volume during a call.



### To use the loudspeaker during a voice call

- 1 ▶ **More** ▶ **Turn on speaker** to turn on the loudspeaker.
- 2 ▶ **More** ▶ **Turn off speaker** to turn off the loudspeaker.

 *Do not hold the phone to your ear while using the loudspeaker. This could damage your hearing.*

## Calling

### To turn off the microphone

- 1 Press and hold .
- 2 To resume the conversation, press and hold  again.

## Receiving calls

When you receive a call, the phone rings and the caller's number is displayed (if your subscription includes the Calling Line Identification service and the caller's number is identified).

If the number is in your contacts, the name, number, and picture (if assigned) are displayed. If the number is a restricted number, **Withheld** is displayed.

### To answer a call

► Answer.

### To reject a call





► Busy or quickly press a volume button twice.

### Missed calls

If you have missed a call, and if **New events** is set to **Activity menu**, the missed call appears in the **Activity menu**. ► Call to call the missed number.

If **New events** is set to **Pop-up**, **Missed calls:** appears, indicating the number of missed calls. To view the missed calls in the call list ► **Yes**. If you want to view the missed calls later ► **No**.

### To check your missed calls

- 1 From standby ► **Calls** ► the **Missed** tab. Use  or  to scroll between the tabs.
- 2 Use  or  to scroll to a number and ► **Call** to call a number.

## Automatic redialling

### To re-dial a number

If the connection of the call failed and **Retry?** is displayed ► **Yes**.



*Do not hold the phone to your ear while waiting. When the call is connected, the phone gives a loud signal.*

The phone redials the number up to ten times or until:

- The call is connected
- You press **Cancel**
- You receive a call

Automatic redialling is not available for data calls.

## Making international calls

When you make an international call, the + sign replaces the international prefix number of the country from which you are calling. You can make a call from abroad, using another network, provided your network operator has an agreement with that network.

### To make international calls

- 1 Press and hold  until a + sign appears on the screen.
- 2 Enter the country code, area code (without the leading zero) and phone number ► Call.

## Emergency calls

Your phone supports the international emergency numbers, for example, 112 and 911. This means that these numbers can normally be used to make an emergency call in any country, with or without a SIM card inserted, if a 3G (UMTS) or GSM network is within range.

 *In some countries, other emergency numbers may also be promoted. Your network operator may therefore have saved additional local emergency numbers on the SIM card.*

### To make an emergency call

Enter, for example, 112 (the international emergency number) ► Call.

### To view your local emergency numbers

- Contacts ► Options ► Special numbers
- Emergency nos.

## Video call

With video call, you can see the person you are talking to on your screen.

### Before you start

To make a video call, both you and the person you are calling need a subscription that supports the 3G (UMTS) service, and you need to be within range of a 3G (UMTS) network. 3G (UMTS) service is available when the 3G icon appears in the status bar.



### Video call demo mode

You can use the video call functions without making a call, if you, for example, want to prepare a view and check how it looks before calling. Press and hold . Most video call functions are available in the demo mode.

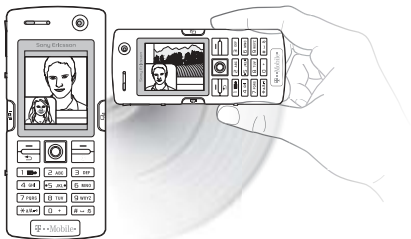

## Calling

### To make a video call





- 1 Press and hold  when 3G (UMTS) service is available.
- 2 Enter the phone number and press **Call**. To retrieve a phone number from your contacts ► **Call...** ► **Contacts** and scroll to the phone number you want to call ► **Call** or press and hold .
- 3 Press **Camera** or open the lens cover to switch cameras from the front camera to the back camera. Hold the phone horizontally, so that the person you are talking to will see the image at a correct angle.

### To adjust the brightness of the outgoing video

Press  to decrease the brightness, or  to increase the brightness of the outgoing video picture.

### To zoom the outgoing video in or out

Press  to zoom in the outgoing video and press  to zoom out.

### To accept an incoming video call

Press **Answer**.

### To end a video call

During an ongoing video call, press **End call**.

### Video call options

Press  when using the front camera to view, and select from, the following options:

- **Stop camera/Start camera** – turn off and on the outgoing video camera. An alternative picture is shown when the camera is off.
- **Turn off speaker/Turn on speaker** – turn off and on the incoming sound during a video call.
- **Mute microphone/Unmute mic.** – turn off and on the microphone during a video call (this option is available during calls).

- **Switch pictures** – choose between showing the incoming or the outgoing video in full size display.
- **Hide small pic./Show small pic.** – choose if you want to hide or show the small picture.
- **Night mode** – use when the lighting conditions are poor. This setting affects the outgoing video.
- **Advanced** – to view, and select, the following options:
  - **Alternative pic.** – this picture will be shown to the other party when you have turned off the camera.
  - **Answer mode** – choose whether the front camera should be on or off when you answer a video call.
  - **Camera quality** – select what picture quality to use for the outgoing video. This setting will take effect at the next call – not during an ongoing call.
  - **Mirror image** – you will see a mirror image of the outgoing video. If you turn mirror image on, you will see yourself as you would in a mirror. The other party will see the picture non-mirrored.
- **Contacts** – select a contact to view during an ongoing call – useful, for example, when you want to check a number or an email address for a contact (this option is visible during calls).
- **Transfer sound** – transfer the sound to and from handsfree equipment using Bluetooth.
- **Demo clip** – turn demo clip on or off.

## Contacts

You can save your contact information in the phone memory as contacts, or on the SIM card as names and numbers. You can choose which contacts information – **Phone contacts** or **SIM contacts** – is shown as default.

For useful information and settings ► **Contacts**  
► **Options**.

### Default contact

If you select to use **Phone contacts** as default, your contacts will show all information saved in **Contacts**. If you select **SIM contacts** as default, the contacts will only show names and numbers saved on the SIM card.

## Calling

### **To select default contacts**



- 1 ▶ **Contacts ▶ Options ▶ Advanced ▶ Default contacts.**
- 2 **Select Phone contacts or SIM contacts.**

### **Contacts**

Contacts is like an address book, in which you can store names, phone numbers and email addresses. You can also add pictures, ringtones and personal information, such as birthday, email, Web and street addresses, to the contacts.

When you add information to a contact, the information is organized under five tabs.

### **To add a phone contact**

- 1 ▶ **Contacts ▶ New contact ▶ Add.**
- 2 **Enter the name directly or press Add and enter the name ▶ OK.**
- 3 **Enter the number directly or press Add and enter the number ▶ OK.**
- 4 **Select a number type.**
- 5 **Scroll between the tabs using  and .** Select fields to enter more information. To enter symbols, for example, @ in an email address ▶ **Symbols and select a symbol ▶ Insert.**
- 6 **When you have entered the information ▶ Save.**

### **SIM contacts**

On your SIM card, you can save entries as a name with a single number. The number of entries you can save depends on the amount of memory available on the SIM card, see **Contacts ▶ Options ▶ Advanced ▶ Memory status.**



*Contact your network operator for more information.*

### **To add a SIM contact**

If SIM contacts are default contacts, follow the same steps as for adding a phone contact. You can add only name and number to SIM contacts.

### **Always save on the SIM card**

You can set the phone to save entries automatically to the SIM card. With this setting, names and phone numbers that you add to or edit in your phone contacts in the phone memory are also saved on the SIM card. The number of phone numbers that can be saved depends on the type of SIM card.

### **To automatically save names and phone numbers to the SIM card**

- 1 ▶ **Contacts ▶ Options ▶ Advanced ▶ Auto save on SIM.**
- 2 **Select On.**



### Checking the memory

With the memory status function, you can check how many positions you have left in the phone memory and SIM memory.

If the memory is full, you must delete contacts to be able to add new contacts, ► [26 To delete a contact](#).





### To check the memory

► [Contacts](#) ► [Options](#) ► [Advanced](#) ► [Memory status](#).

### Pictures and personal ringtones

You can add a picture and a personal ringtone to a phone contact. When that person calls, the picture is displayed (provided your subscription supports the Calling Line Identification service) and the ringtone is played.

### To add a picture or a ringtone to a phone contact

- 1 ► [Contacts](#) and select the contact you want to add a picture or ringtone to ► [More](#) ► [Edit contact](#).
- 2 Use , ,  and  to scroll to the relevant tab. ► [Picture:](#) or [Ringtone](#) ► [Add](#).
- 3 Select a picture or sound. ► [Save](#) to save the contact.



### Calling contacts

You can call one of the numbers saved for one of your contacts, or a number on your SIM card.

If phone contacts are set as default, you can choose to call from contacts or from the SIM card.

If SIM contacts are set as default, you can only call the numbers on the SIM card.

### To call a phone contact

- 1 ► [Contacts](#). Scroll to, or enter the first letter or letters of the contact you want to call.
- 2 When the contact is highlighted, press  or  to select a number ► [Call](#). To make a video call, press and hold  when the contact is highlighted.

### To call a SIM contact

- 1 ► [Contacts](#). If SIM contacts are set as default, select the name and number you want to call from the list ► [Call](#).
- 2 If phone contacts are set as default ► [Contacts](#) ► [Options](#) ► [SIM contacts](#) and select the name and number you want to call from the list ► [Call](#).

## Calling

### **Ask to save**

When you end a call or receive a message, the phone can prompt you to add a phone number or email address to your contacts.





### **To activate ask to save**

- ▶ **Contacts** ▶ **Options** ▶ **Advanced** ▶ **Ask to save**
- ▶ **On**.

## **Updating contacts**

You can easily update and edit any information in your contacts.

### **To edit a phone contact**

- 1 ▶ **Contacts** and select a contact ▶ **More**  
▶ **Edit contact**.
- 2 Use , ,  and  to scroll to the relevant tab and edit the information you want to edit  
▶ **Save**.

### **To edit a SIM contact**

- 1 If SIM contacts are set as default ▶ **Contacts** and select the name and number you want to edit. If phone contacts are set as default ▶ **Contacts** ▶ **Options** ▶ **SIM contacts**. Select the name and number you want to edit.
- 2 ▶ **More** ▶ **Edit** and edit the name and number.

### **To delete a contact**

- ▶ **Contacts** and scroll to the contact you want to delete, press .

### **To delete all contacts**

- 1 ▶ **Contacts** ▶ **Options** ▶ **Advanced**  
▶ **Delete all contacts**.
- 2 ▶ **Yes** and enter the phone lock code ▶ **OK**. The default phone lock code is 0000. Names and numbers that are saved on the SIM card are not deleted.

### **Default items for phone contacts**

A default item is displayed in the first position for a phone contact, and is therefore quicker to access. You can set the default item – a phone number, email address or a Web address – to be displayed first for each contact. If you do not set your own default item, the mobile phone number is the default item.

### **To set the default item for a contact**

- 1 ▶ **Contacts** and scroll to a contact ▶ **More**  
▶ **Default number**.
- 2 Select the phone number, email address or Web address that you want as default item.

## Sending contacts

You can send contacts using one of the available transfer methods.

### To send a contact

- ▶ **Contacts** and select a contact ▶ **More**
- ▶ **Send contact** and select a transfer method.

### To send all contacts

- ▶ **Contacts** ▶ **Options** ▶ **Advanced**
- ▶ **Send all contacts** and select a transfer method.

## Synchronizing contacts

You can back up and synchronize your contacts with a contacts application on the Web. For more information, please contact your service provider. You can also synchronize your contacts with a computer application, ➡ *64 Synchronizing*.

### To synchronize contacts remotely

- 1 ▶ **Contacts** ▶ **Options** ▶ **Sync. contacts**.
- 2 If you have more than one account, select which account to use ▶ **Select**. If you do not have an account in the phone, ➡ *65 To enter the remote synchronization settings*.

## Copying contacts

You can copy names and numbers to and from your phone contacts and the SIM card. Choose if you want to copy all numbers, or a single number.



*When you select to copy all contacts from the phone to the SIM card, all existing information on the SIM card will be replaced.*

### To copy names and numbers to the SIM card

- 1 ▶ **Contacts** ▶ **Options** ▶ **Advanced**  
▶ **Copy to SIM**.
- 2 Select **Copy all** or **Copy a number**.

### To copy names and numbers to phone contacts





- 1 ▶ **Contacts** ▶ **Options** ▶ **Advanced**  
▶ **Copy from SIM**.
- 2 Select **Copy all** or **Copy a number**.

## Call list

The numbers of the most recent calls are saved in the call list. Dialed, answered and missed calls are listed under separate tabs.

## Calling

### **To call a number from the call list**

- 1 ▶ Calls from standby and select a tab.
- 2 Use , ,  and  to scroll to the name or number you want to call ▶ Call, or press and hold  to make a video call.

### **To add a number from the call list to contacts**

- 1 ▶ Calls from standby and select a tab.
- 2 Scroll to the number you want to add ▶ More ▶ Save number.
- 3 ▶ New contact to create a new contact, or select an existing contact to add the number to.

### **To clear the call list**

- ▶ Calls ▶ the All tab ▶ More ▶ Delete all.

## Speed dialling

You can save the phone numbers that you want to reach easily in positions 1-9 in your phone.

### **To speed dial**

From standby, enter the position number and ▶ Call.

### **To set or replace speed dialling numbers**

- 1 ▶ Contacts ▶ Options ▶ Speed dial.
- 2 Scroll to the position in the list ▶ Add or ▶ Replace.
- 3 Select an existing contact to add the position number to.

## Voicemail

If your subscription includes an answering service, callers can leave a voicemail message when you cannot answer a call.

### **Calling your voicemail service**

You can easily call your voicemail service by pressing and holding . If you have not set your voicemail number, you will be asked if you want to enter the number. ▶ Yes to enter the number. You get the number from your network operator.

### **To enter your voicemail number**

- ▶ Messaging ▶ Settings ▶ Voicemail number.

## Voice control

With your phone, you can use your voice to:

- Voice dial – call someone by saying the name.
- Activate voice control by saying a “magic word”.
- Answer and reject calls when using a handsfree kit.

Voice commands can only be saved in the internal phone memory, not on the SIM card. When recording, make sure that you are in a quiet environment and try to use names that are distinct from each other, ➤ *31 Tips when recording and using voice commands.*



## Voice dialling

You can voice dial by saying a pre-recorded voice command. Start voice dialling from standby using the phone, a portable handsfree, a Bluetooth headset or by saying your magic word.

You must first activate the voice dialling function and record your voice commands. An icon appears next to a phone number that has a voice command.

### To activate voice dialling and record names

- 1 ▶ Settings ▶ the General tab ▶ Voice control ▶ Voice dialling ▶ Activate ▶ Yes ▶ New voice ▶ Add and select a contact.

- 2 If the contact has more than one number, use  and  to view the numbers. Select the phone number to which you want to add the voice command. Now you are going to record a voice command such as “John mobile” for the phone number you selected.
- 3 Instructions appear. Wait for the tone and say the command that you want to record. The voice command is played back to you.
- 4 If the recording sounds ok ▶ Yes. If not ▶ No and repeat step 3.
- 5 To record another voice command for a contact ▶ New voice ▶ Add again and repeat steps 2-4 above.

### To make a call from the phone

- 1 From standby, press and hold one of the volume buttons.
- 2 Wait for the tone and say the name you recorded earlier, for example “John mobile”. The name is played back to you and the call is connected.

### To make a call with a handsfree

From standby, press the handsfree button, or the Bluetooth headset button.

## Calling

### Caller name

You can choose whether you want to hear the recorded contact name when you receive a call from that contact.

### To turn the caller name on or off

- ▶ Settings ▶ the General tab ▶ Voice control
- ▶ Play caller name.

### The magic word

You can record a magic word and use it as a voice command to allow totally handsfree access to voice dialling. Instead of pressing and holding a volume button to voice dial, you say the magic word and then one of your recorded voice commands. The magic word is especially suitable when using a car handsfree kit.

 Choose a long, unusual word or phrase that can easily be distinguished from ordinary background speech.

### To activate and record the magic word

- ▶ Settings ▶ the General tab ▶ Voice control ▶ Magic word ▶ Activate.
- Instructions appear. ▶ **Continue**. Wait for the tone and say the magic word.

- Instructions appear. ▶ **Continue** and select the environments in which you want your magic word to be activated. You can select several alternatives.

### Voice answering

You can answer or reject incoming calls by using your voice, when using a portable or car handsfree kit.

 You can only use a MIDI, WAV, EMY or IMY file as a ringtone with voice answering.

### To activate voice answering and record voice answer commands

- ▶ Settings ▶ the General tab ▶ Voice control ▶ Voice answer ▶ Activate.
- Instructions appear. ▶ **Continue**. Wait for the tone and say “Answer”, or another word. If the recording sounds ok ▶ **Yes**. If not ▶ **No** and repeat step 2.
- Say “Busy”, or another word ▶ **Yes**.
- Instructions appear. ▶ **Continue** and select the environments in which you want voice answering to be activated. You can select several alternatives.

**To answer a call using voice commands**

When the phone rings, say “Answer” and the call is connected.

**To reject a call using voice commands**

When the phone rings, say “Busy”. The call is rejected. The caller is diverted to voicemail, if activated, or hears a busy tone.

**Editing your voice commands**

You can edit all your voice commands saved in **Contacts**. Select the contact you want to edit a voice command for ► **More** ► **Edit contact**. Scroll to the relevant tab and edit your voice command.

**To re-record a voice command**

- 1 ► **Settings** ► the **General** tab ► **Voice control** ► **Voice dialling** ► **Edit names**.
- 2 Select a voice command ► **More** ► **Replace voice**.
- 3 Wait for the tone and say the command.

**Tips when recording and using voice commands**

If your phone cannot detect your voice command, one of the following might have happened:

- You spoke too softly – try speaking louder.
- You held the phone too far away – hold it as you do during a call.
- The voice command was too short – it should be around one second long and more than one syllable.
- You spoke too late or too soon – speak immediately after the tone.
- You did not record the voice command when the handsfree was attached – for voice control with a handsfree kit, record when the handsfree is attached.
- You used another intonation – use the same intonation as in the recorded voice command.

**Diverting calls**

If you cannot answer incoming calls, you can divert them to another number, for example, your answering service.





*When the Restrict calls function is activated, some Divert calls options are not available.*

## Calling

You can choose between the following divert options:

- **Divert always** – divert all calls.
- **When busy** – divert calls if you are already on the phone.
- **Not reachable** – divert calls if your phone is turned off or if you are unreachable.
- **No reply** – divert calls that you do not answer within a specified time limit.



### **To activate a call divert**

- 1 ▶ **Settings** ▶ the **Calls** tab ▶ **Divert calls**. Use  or  to scroll between the tabs.
- 2 Select a call type and then one of the divert options ▶ **Activate**.
- 3 Enter the phone number to which you want your calls to be diverted, or press **Look up** to find the contact ▶ **OK**.

### **To deactivate a call divert**

Scroll to the divert option ▶ **Deactivate**.

### **To check all divert options**

▶ **Settings** ▶ the **Calls** tab ▶ **Divert calls** ▶ **Check all**.  
Use  or  to scroll between the tabs.



## More than one call

You can handle more than one call simultaneously.

### **Call waiting service**

When the service is activated, you hear a beep if you receive a second call.

### **To activate or deactivate the call waiting service**

▶ **Settings** ▶ the **Calls** tab ▶ **Manage calls** ▶ **Call waiting**. Use  or  to scroll between the tabs.

### **To make a second call**

- 1 ▶ **More** ▶ **Hold call** to put the ongoing call on hold.
- 2 Enter the number you want to call ▶ **More** ▶ **Call**.

### **Receiving a second voice call**

When you receive a second call, you can do the following:

- ▶ **Answer** and put the ongoing call on hold.
- ▶ **Busy** to reject the second call and continue the ongoing call.
- ▶ **Replace active call** to answer the second call and end the ongoing call.



**Handling two voice calls**

When you have one ongoing call and one call on hold, you can do the following:

- ► **Switch calls** to switch between the two calls.
- ► **More ► Join calls** to join the two calls into a conference call.
- ► **More ► Transfer call**, to connect the two calls. You are disconnected from both calls.
- ► **End call** to end the ongoing call, then press **Yes** to retrieve the held call.
- ► **End call ► No** to end both calls.
- You cannot answer a third call without ending one of the first two calls or joining them into a conference call.

**Conference calls**

In a conference call, you can have a joint conversation with up to five other people. You can also put a conference call on hold and make another call.



*There may be additional charges for calls involving multiple parties.*

**To join the two calls into a conference call**

- **More ► Join calls.**

**To add a new participant**

- 1** ► **More ► Hold call** to put the joined calls on hold.
- 2** ► **More ► Add call** and call the next person you want to include in the conference call.
- 3** ► **More ► Join calls.**
- 4** Repeat steps 1-3 to include more participants.

**To release a participant**

- **More ► Release part** and select the participant that you want to release from the conference call.

**To have a private conversation**

- 1** ► **More ► Talk to** and select the participant that you want to talk to.
- 2** ► **More ► Join calls** to resume the conference call.

**Two voice lines**



If you have a subscription that supports an alternate line service, your phone may have two voice lines with different phone numbers.

**To select a line for outgoing calls**

- **Settings ► the Calls tab** and select line 1 or 2. Use or to scroll between the tabs.

## Calling

### **To change the name of a line**

▶ Settings ▶ the Display tab ▶ Edit line names and select one of the lines to edit the name. Use  or  to scroll between the tabs.

## **My numbers**

View, add and edit your own phone numbers.



### **To check your phone numbers**

▶ Contacts ▶ Options ▶ Special numbers  
▶ My numbers and select one of the options.

## **Accept calls**

With the accept calls service, you can choose to receive calls only from certain phone numbers. Other calls are automatically rejected by a busy tone. If the call divert option **When busy** is activated, calls are diverted instead of rejected by a busy tone. The phone numbers of calls you have rejected are saved in the call list.

### **To add numbers to the accepted callers list**

- ▶ Settings ▶ the Calls tab ▶ Manage calls ▶ Accept calls ▶ Only from list ▶ Edit ▶ Add. Select a contact. Use  or  to scroll between the tabs.
- To add a group of contacts to the accepted callers list ▶ **Groups** (requires that you have created groups, ➤ *37 Groups*).

### **To accept all calls**

▶ Settings ▶ the Calls tab ▶ Manage calls ▶ Accept calls ▶ All callers. Use  or  to scroll between the tabs.



## **Restricted dialling**

You can use the restrict calls service to restrict outgoing and incoming calls. You need a password which you get from your service provider.





*If you divert incoming calls, you cannot activate some Restrict calls options.*

The following calls can be restricted:

- **All outgoing** – All outgoing calls.
- **Outgoing intl** – All outgoing international calls.

- **Outgoing intl roam.** – All outgoing international calls except to your home country.
- **All incoming** – All incoming calls.
- **Inc. when roaming** – All incoming calls when you are abroad (when roaming).

### **To activate or deactivate a call restriction**

- 1 ▶ Settings ▶ the Calls tab ▶ Manage calls ▶ Restrict calls and select an option. Use  or  to scroll between the tabs.
- 2 Select **Activate** or **Deactivate**, enter your password ▶ **OK**.



### **Fixed dialling**

The fixed dialling function allows calls to be made only to certain numbers saved on the SIM card. The fixed numbers are protected by your PIN2.

-  *You can still call the international emergency number, 112, even when the fixed dialling function is activated.*

Partial numbers can be saved. For example, saving 0123456 allows calls to be made to all numbers starting with 0123456.



*When fixed dialling is activated, you cannot view or manage any phone numbers that are saved on the SIM card.*

### **To activate or deactivate fixed dialling**

- 1 ▶ Contacts ▶ Options ▶ Special numbers ▶ Fixed dialling and select **Activate** or **Deactivate**.
- 2 Enter your PIN2 ▶ **OK** and then ▶ **OK** again to confirm.

### **To save a fixed number**

- ▶ Contacts ▶ Options ▶ Special numbers  
▶ Fixed dialling ▶ Fixed numbers ▶ New number  
and enter the information.



## Calling



### Call time and cost

During a call, the duration of the call is shown on the screen. You can check the duration of your last call, outgoing calls and the total time.





#### To check the call time

► **Settings** ► the **Calls** tab ► **Time & cost** ► **Call timers**. Use  or  to scroll between the tabs.

## Additional calling functions

### Tone signals

You can use telephone banking services or control an answering machine by sending tone signals during a call.

- To send the tones, press the keys  - ,  or .
- To clear the screen after the call is finished, press .
- To turn the tones off during a call, ► **More** ► **Disable tones**.



### Notepad

You can use the phone to make a note of a phone number during a call. When you press the number keys, the person you are talking to hears tone signals. When you end the call, the number remains on the screen. ► **Call** to call the number. ► **More** ► **Save number** and select a contact to save the number. If you want to create a new contact and save the number ► **New contact**.

### Showing or hiding your number

If your subscription supports the Calling Line Identification Restriction (CLIR) service, you can hide your phone number when making a call.

#### To always show or hide your phone number

- 1 ► **Settings** ► the **Calls** tab ► **Show or hide no.**  
Use  or  to scroll between the tabs.
- 2 Select **Show number**, **Hide number** or **Network default**.

## Groups

You can create a group of numbers and email addresses. By doing so, you can send messages to several recipients at the same time, ➤ *38 Messaging*. You can also use groups (with numbers) when you create accepted callers lists, ➤ *34 Accept calls*

### **To create a group of numbers and email addresses**

- 1 ▶ **Contacts** ▶ **Options** ▶ **Groups** ▶ **New group** ▶ **Add**.
- 2 Enter a name for the group ▶ **Continue**.
- 3 ▶ **New** ▶ **Add** to find and select a contact number.
- 4 Repeat step 3 to add more numbers. ▶ **Done**.

## Business cards

You can add your own business card as a contact.

### **To add your own business card**

- ▶ **Contacts** ▶ **Options** ▶ **My business card** and add information for your business card ▶ **Save**.

### **To send your business card**

- ▶ **Contacts** ▶ **Options** ▶ **My business card**
- ▶ **Send my card** and select a transfer method.



# Messaging

*Text messaging, picture messaging, voice messaging, email.*

## Text messaging (SMS)

Text messages can contain simple pictures, animations, melodies and sound effects.

 *If you send a text message to a group, you are charged for each member of that group.*

### Before you start

First make sure that the number of your service centre is set. The number is supplied by your service provider and is usually saved on the SIM card.

### To set the service centre number

- 1 ▶ **Messaging** ▶ **Settings** ▶ **Text message** ▶ **Service centre**. If the service centre number is saved on the SIM card, it is shown in the list.
- 2 If there is no number in the list ▶ **Add** and enter the number, including the international “+” sign and country code ▶ **Save**.

### Sending text messages

For information about entering letters,  
➡ **15 Entering letters**.

 *Some language-specific characters use more space. For some languages you can deactivate **National chars** to save space, ➡ **16 Options list**.*

### To write and send a text message

- 1 ▶ **Messaging** ▶ **Write new** ▶ **Text message**.
- 2 Write your message ▶ **Continue**. If you want to save the message for later, press . ▶ **Yes** to save it in **Drafts**.
- 3 ▶ **Enter phone no.** and enter the recipient's phone number, or ▶ **Contacts look-up** to retrieve a number or a group from **Contacts**. To enter an email address ▶ **Enter email addr**. A list below the send options shows the last used recipients. You can also select a recipient from this list. ▶ **Send**.

 *To send a message to an email address, you need to set an email gateway number; ▶ **Messaging** ▶ **Settings** ▶ **Text message** ▶ **Email gateway**. The number is supplied by your service provider.*

### **To insert an item in a text message**

- 1 While writing your message ► More ► Add item.
- 2 Select an item type and then select an item.

### **Receiving text messages**

When you receive a text message, it appears in the **Activity menu** if **New events** is set to **Activity menu**.

► **View** to read the message.

If **New events** is set to **Pop-up**, you are asked if you want to read the text message. ► **Yes** to read the text message or ► **No** if you want to read the message later.

When you have read the text message ► **More** to view a list of options. Press  to close the text message.

### **To call a number in a text message**

Select the phone number ► **Call**.

### **Saving and deleting text messages**

Text messages are saved in the phone memory. When the phone memory is full, you must delete messages or move them to the SIM card to be able to receive new messages. Messages that you have saved on the SIM card remain there until you delete them.

### **To save a message to the SIM card**

- **Messaging** ► **Inbox** ► **More** ► **Save message**
- **Saved messages**.

### **To save an item from a text message**

- 1 Select the phone number, Web address, picture or sound that you want to save in the message ► **More**.
- 2 If you have selected to save a phone number ► **Use** ► **Save number**. If you have selected a Web address ► **Save bookmark**, a picture ► **Save picture**, a melody ► **Save sound**.

### **To save or delete several messages**

- 1 ► **Messaging** and select a folder.
- 2 Select a message ► **More** ► **Mark several**.
- 3 Scroll and select more messages by pressing **Mark** or **Unmark**.
- 4 ► **More** ► **Save messages** or ► **More** ► **Delete messages**.

### **To delete a message**

- 1 ► **Messaging** and select a folder.
- 2 Select the message that you want to delete and press .

## Messaging

### Long messages

The number of characters that a text message can contain depends on the language you are writing in. You can send a longer message by linking two or more messages. You are charged for each of the messages linked in a long message. You may not receive all parts of a long message at the same time.



*Check with your service provider for the maximum number of messages that can be linked.*

### To turn long messages on

- ▶ Messaging ▶ Settings ▶ Text message
- ▶ Max. msg length ▶ Max. available.

### Templates

If you have messages that you send often, you can save these as templates. You can create your own templates.

### To create a template

- 1 ▶ Messaging ▶ Templates ▶ New template  
▶ Add ▶ Text.
- 2 Write the message ▶ OK.
- 3 Enter a title for the message ▶ OK.

### Message options

You can set a default value for several message options or choose the settings each time you send a message. To check the delivery status of a sent message, the delivery report option must be on.

### To set a default text message option

▶ Messaging ▶ Settings ▶ Text message and select an option.

### To set a message option for a specific message

- 1 When you have selected a recipient to send your text message to ▶ More ▶ Advanced.
- 2 Select the option that you want to change  
▶ Edit and select a new setting.
- 3 ▶ Done when you have changed the options.

### To check the delivery status of a sent message

▶ Messaging ▶ Sent messages and select a text message ▶ View ▶ More ▶ Details.





## Picture messages (MMS)

Picture messages can contain text, pictures, video clips, camera pictures, sound recordings, and business cards. Both you and the receiver of the picture message must have a subscription that supports picture messaging. You can send picture messages to a mobile phone or an email address,

➔ *44 Email.*

### Before you start

Before sending a picture message, make sure that:

- 1 The address of your message server is set
  - ▶ **Messaging** ▶ **Settings** ▶ **Picture message**
  - ▶ **Message server.**
- 2 You have entered the correct settings
  - ▶ **Messaging** ▶ **Settings** ▶ **Picture message**
  - ▶ **Internet profile.** If no Internet profile exists
  - ▶ **New profile** and enter the required settings.

Settings may already be entered when you buy your phone. If not, you can automatically receive all the settings in a message from your network operator or from [www.SonyEricsson.com/support](http://www.SonyEricsson.com/support).

## Creating and sending picture messages

When composing a picture message, you can select different items such as: **Picture**, **Text**, **Sound**, **Video**, **Sound recording** and **Page**. You can also select **Use camera** to take a new picture or record a new video clip.

Before sending a picture message, you can select from different options to adjust and enhance your message.

### To create and send a picture message

- 1 ▶ **Messaging** ▶ **Write new** ▶ **Picture msg** ▶ **Add** to view a list of items to add to your message. Select an item.
- 2 ▶ **Add** to add more items to the message. You can view and select options to enhance the message by highlighting items in the message and pressing the left selection key.
- 3 When you have finished composing your message ▶ **More** ▶ **Send.**

## Messaging

- ▶ Enter phone no. and enter the recipient's phone number, or ▶ **Contacts look-up** to retrieve a number or a group from Contacts. To enter an email address ▶ **Enter email addr.** A list below shows the last 10 recipients. You can also select a recipient from this list. ▶ **Send.**

### **To make a call while creating a picture message**

- While writing your message ▶ **More.**
- ▶ **Make a call** and enter or retrieve a phone number ▶ **Call.** You return to the message.
- To end the call ▶ **More** ▶ **End call.**

### **Default message options**

You can request a read report, a delivery report and set a priority for a specific message.

### **To set a default message option**

▶ **Messaging** ▶ **Settings** ▶ **Picture message** and select one of the options.

### **Additional send options**

You can edit the message subject and add or edit recipients and attachments.

### **To select additional send options**

When you have entered the recipient's phone number ▶ **More** and select one of the options.

### **Receiving picture messages**

When you receive an automatically downloaded picture message, the picture message appears in the **Activity** menu if **New events** is set to **Activity menu.** ▶ **View** to read the message.

If **New events** is set to **Pop-up**, you are asked if you want to read the picture message. ▶ **Yes** to read or play the message. ▶ **Stop** to stop the message. When you have read the message, select **Reply** to reply immediately or select **More** to view a list of options. Press  to close the message.



*You can select a message from the list of messages and press  to delete the entire message.*

### **To save items from a picture message**

When you have viewed a picture message ▶ **More** ▶ **Save items** and select an item from the list that appears.

### Delete picture messages

Picture messages are saved in the phone memory. When the phone memory is full, you must delete messages to be able to receive new messages,  
 ➤ 39 *Saving and deleting text messages.*

### Templates

You can base your message on one of the templates. You can also add new templates.

#### **To use a template for a picture message**

- 1 ▶ Messaging ▶ Templates and select a template.
- 2 ▶ Use ▶ Add to add new items.
- 3 ▶ More ▶ Send to send the message.

### Automatic download

You can select how you want your picture messages to be downloaded.

- ▶ Messaging ▶ Settings ▶ Picture message
- ▶ Auto download to view the following:
  - **Always** – your phone automatically downloads messages to your phone as soon as they come to your network operator’s server. This is default.

- **Ask in roaming** – you will be asked if you want to download messages when you are in a network other than your home network.
- **Not in roaming** – the messages are never downloaded when you are in a network other than your home network.
- **Always ask** – you will always be asked if you want to download messages, regardless of network used.
- **Off** – new messages appear in the inbox as icons. Select the message ▶ **View** to download.



### Voice messages

Voice messages offer a quick way to send and receive sound recordings as messages. A voice message can only contain one sound recording. Both you and the receiver of the voice message must have a subscription that supports picture messaging.

#### **To record and send a voice message**

- 1 ▶ Messaging ▶ Write new ▶ Voice message.  
The sound recorder starts.
- 2 Record your message. ▶ **Stop** to end the recording.
- 3 ▶ **Send** to send the message.

## Messaging

- ▶ Enter phone no. and enter the phone number of the recipient, or ▶ **Contacts look-up** to retrieve a number or a group from Contacts. To enter an email address ▶ **Enter email addr.** A list below the send options shows the last 10 recipients. You can also select a recipient from this list. ▶ **Send**.

### Receiving voice messages

When you receive a voice message, the voice message appears in the **Activity menu** if **New events** is set to **Activity menu**. ▶ **Play** to listen to the message.

If **New events** is set to **Pop-up**, you are asked if you want to listen to the voice message. ▶ **Yes** to listen to the voice message or ▶ **No** if you want to listen to the message later. When you have listened to the voice message ▶ **More** to view a list of options. Press  to close the message.



### Email

You can use your phone to send and receive email messages. You can use the same email settings in your phone as in your computer email program. For more information, contact your network or service provider.

### Before you start

First make sure that:

- Settings are in your phone, if not, ➔ *61 Settings*.
- You have set up and selected an email account. To download the email account settings visit [www.SonyEricsson.com/support](http://www.SonyEricsson.com/support). Have your email account details at hand.

### Default email account

If you have both an office and a home email account, you can set one of them as default:

▶ **Messaging** ▶ **Email** ▶ **Settings** ▶ **Account settings** and select an account.

### To write and send an email message

- ▶ **Messaging** ▶ **Email** ▶ **Write new**.
- Write the subject for your message ▶ **Continue** and then write the text ▶ **Continue**.
- ▶ **Enter email addr.** to enter an email address or ▶ **Contacts look-up** to retrieve an address from Contacts.
- Select **Send** to send your email message or select **More** to view a list of options for your message.

### **To send, receive and read email messages**

- 1 ▶ **Messaging** ▶ **Email** ▶ **Inbox** ▶ **Send&rec** (when inbox is empty) or ▶ **Messaging** ▶ **Email** ▶ **Inbox** ▶ **More** ▶ **Send & receive** to send or download new messages.
- 2 Select a message ▶ **View** to read it.

### **To reply to an email message**

- 1 Open the email message ▶ **Reply**.
- 2 ▶ **Include message** to include the original message in your reply or ▶ **Write new** to exclude the original message. Write your message ▶ **Continue**.
- 3 ▶ **Send** to send your email message or ▶ **More** to view a list of options for your message.



### **To save an email address or a phone number in an email message**

- 1 Select the email address or phone number that you want to save ▶ **More**.
- 2 To save an email address ▶ **Save address**. To save a phone number ▶ **Use** ▶ **Save number**.

### **To save an email message**

- 1 Open the email message ▶ **More** ▶ **Save message** ▶ **Saved email**.
- 2 The message is saved in **Saved email** in the **Email** menu.



*The number of email messages that can be saved depends on how much memory there is left in the phone. From standby, press  or  to view status information. All email messages are also saved on your email server, and you can view both older and newer messages on the server.*

### **To save several email messages**

- 1 ▶ **Messaging** ▶ **Email** ▶ **Inbox**.
- 2 Select a message ▶ **More** ▶ **Mark several**.
- 3 Scroll and select more messages by pressing **Mark** or **Unmark**.
- 4 ▶ **More** ▶ **Save messages**.

### **To delete an email message (POP3 users)**

- 1 ▶ **Messaging** ▶ **Email** ▶ **Inbox** and select the message ▶ **More**.

## Messaging

- ▶ **Mark for deletion.** The message is deleted the next time you connect to your email server. If you want to delete several messages  
▶ **Mark several.** Scroll and select more messages by pressing **Mark** or **Unmark**.  
▶ **More** ▶ **Mark for deletion.**

### **To delete an email message (IMAP4 users)**

- ▶ **Messaging** ▶ **Email** ▶ **Inbox** and select the message ▶ **More**.
- ▶ **Mark for deletion.** The message is marked for deletion on the server. If you want to delete several messages ▶ **Mark several.** Scroll and select more messages by pressing **Mark** or **Unmark**. ▶ **More** ▶ **Mark for deletion.**
- ▶ **More** ▶ **Clear inbox.** and select **With send & rec.** or **No send & rec.** to delete messages.

## **Area information**

Area information is a type of text message that is sent to all subscribers within a certain network area. When you receive an area information message, the message automatically appears on the screen. Press **Save** to save the message in your inbox, or **Discard** to delete the message.



*Please consult your service provider for more information about area information.*

### **To turn area information on or off**

- ▶ **Messaging** ▶ **Settings** ▶ **Area info** ▶ **Reception.**

## **Cell information**

The cell information channel is used by some network operators to send messages about a certain network area to their subscribers within that area.

### **To turn on cell information**

- ▶ **Messaging** ▶ **Settings** ▶ **Area info**  
▶ **Cell information.**

## Imaging

Camera, video recorder, pictures, PhotoDJ™.

### Camera and video recorder

Your phone has a digital camera which also works as a digital video recorder. You can take pictures, record video clips, save and view them and send them as email attachments, ➡ *44 To write and send an email message*, or send them in picture messages via picture messaging, ➡ *41 To create and send a picture message*.

#### To activate the camera

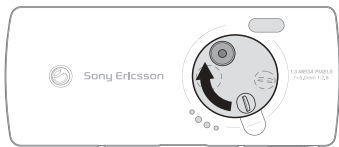

While in standby, slide the lens cover to activate the camera.

#### To take pictures and video clips

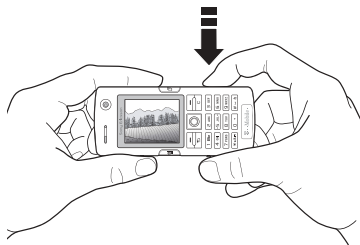

- 1 Use the navigation key to switch between camera and video recorder.
- 2 Press  to take a picture or start recording.
- 3 To end video recording, press again. To deactivate the camera, close the lens cover.

 *If you try to record a strong light source such as direct sunlight or a lamp, the screen may black out or the picture may be distorted.*

#### To use the zoom

Use the volume buttons on the side of the phone to zoom in and zoom out.

## Imaging

### **To adjust brightness**

Use the navigation key to increase or decrease brightness.

### **To turn on the photo light**

To take pictures in a dimly lit environment, press .

### **To view your pictures and video clips**

When the camera or video is activated ► **View**.

### **Camera and video options**

When the camera or video is activated ► **Settings** to view more options. Before you take a picture or make a video clip, the following options are available:

- **Switch to video camera** – to record a video clip instead of taking a picture.
- **Switch to still camera** – to take a picture instead of recording a video clip.
- **Shoot mode** (camera) – select from **Normal** for no frame, **Panorama** to combine several pictures into one wide picture, **Frames** to add a frame to your picture and **Burst** to take four pictures in rapid succession.
- **Shoot mode** (video) – select **High quality video** or **For picture message** if you want to send your video clip as a picture message.

- **Picture size** – choose between 1280x1024, 640x480 and 160x120. All phones that support pictures can receive the size 160x120.
- **Video size** – choose between **Large 176x144** and **Small 128x96**.
- **Turn on night mode** – enhance picture or video quality in poor lighting conditions with longer exposure time.
- **Turn on light** – to enhance lighting conditions.
- **Turn on self-timer** – the picture is taken a few seconds after you press the camera button.
- **Effects** – select different effects for your picture or video.
- **White balance** – adjust the picture or video colour to the lighting conditions.
- **Picture quality** – choose between **Normal** and **Fine** picture quality.
- **Turn on time and date** – add a time and date to your picture.

### **Saving pictures and video clips**

When you have taken a picture or recorded a video clip, it is saved in the phone memory, ► **17 File manager**. You can also choose to store your pictures and video clips on your computer, ► **70 The USB cable**.



### **Sending pictures and video clips**

When you have taken a picture or recorded a video clip, you can send it as a picture message if the file size has not exceeded the limit, ➤ *41 To create and send a picture message*. For settings that affect the file size, ➤ *48 Camera and video options*.

Before you start the receiving phone needs to support data transmission and picture messaging in order to receive and show the picture or video clip.

- Before you send a picture or video clip using picture messaging make sure that you have set the address of your message server for picture messaging, ➤ *41 Picture messages (MMS)* and that Internet settings are entered in your phone, ➤ *61 Settings*.
- Before you send a picture or video clip using email make sure that you have entered settings for a data account and for an email account in your phone, ➤ *44 Email*.

To exchange pictures and video clips using other transfer methods ➤ *50 Exchanging pictures*.

### **To send a picture**

When you have taken a picture ► **Send** to send the picture.

### **To send and play video clips**

When you have finished your recording, ► **Send** to send the video clip.

► **More** ► **Play** to play or press  to delete the video clip.

## **Pictures**

Your phone comes with a number of pictures and animations. You can delete these pictures if you want to free memory. All pictures are saved in **File manager** ► **Pictures**. You can:

- Use a picture as wallpaper and as a screen saver.
- Assign a picture to a contact. ➤ *25 To add a picture or a ringtone to a phone contact*.
- Exchange pictures using one of the available transfer methods.

## **Handling pictures**

You can add, edit and delete pictures in **File manager**. The number of pictures that you can save depends on the size of the pictures, ➤ *50 To view information about a picture or video clip*. File types supported are, for example, GIF, JPEG, WBMP, BMP, PNG and SVG-Tiny.

## Imaging

### **To view your pictures**

- 1 ▶ File manager ▶ Pictures.
- 2 The pictures are shown in thumbnail view.  
To get a full view ▶ View.

### **To display pictures in a slide show**

- 1 ▶ File manager ▶ Pictures and scroll to a picture.
- 2 ▶ View ▶ More ▶ Slide show.

### **To view information about a picture or video clip**

- 1 ▶ File manager ▶ Pictures or Videos, select the picture or video clip.
- 2 ▶ More ▶ Information.

### **Using pictures**







You can use a picture for several purposes, for example, add it to a contact, use it in the start-up screen, or use it as a screen saver.

The screen saver is activated automatically when you have not pressed any key for a few seconds. After a few more seconds, the screen saver changes to sleep mode, to save power. Press any key on the keypad and the screen turns on again. If you have a picture as wallpaper, this picture is shown in standby mode.

### **To use a picture**

- 1 ▶ File manager ▶ Pictures and scroll to the picture you want to use ▶ More ▶ Use as.
- 2 Select what you want to use the picture for.

### **PhotoDJ™**

When editing pictures press , , ,  and the following keys:  to activate the tool,  to select the tool and  to select a colour.

### **To edit and save a picture**

- 1 ▶ Entertainment ▶ PhotoDJ™ and scroll to the picture you want to edit ▶ Select.
- 2 To save the edited picture ▶ More ▶ Save picture.

### **Exchanging pictures**

You can exchange pictures using one of the available transfer methods. Please note that you are not allowed to exchange copyright-protected material. For more information on sending pictures in messages ➡ *41 Picture messages (MMS)*.

### **To send a picture**

- ▶ File manager ▶ Pictures and scroll to the picture you want. ▶ More ▶ Send and select a transfer method.

**To receive and save a picture**

- 1 Open the message you received the picture in, or turn on Bluetooth or the infrared port if one of these transfer methods was used to send the picture.
- 2 If you received the picture in a message, select the picture and save it. If you received the picture via Bluetooth or infrared, follow the instructions that appear on the screen.

 *All phones that support pictures can receive the picture size 160x120. Some phones that support pictures cannot receive picture sizes of more than 160x120. The best picture size to view on a computer is 1280x1024.*

**Remote screen**

You can view your pictures on a remote screen, for example, a TV, using a compatible Bluetooth adapter. The adapter is an accessory and not included in the box. You can then use the phone to control the screen. Use the slide show function to show several pictures in succession.

**To connect to a remote screen**

► **File manager** ► **Pictures** and scroll to the picture you want ► **View** ► **More** ► **Remote screen**. The phone searches for other Bluetooth devices and a list of available devices is displayed. Select the device you want to use.

# Entertainment

*Media player, radio, ringtones, MusicDJ™, VideoDJ™, sound recorder, themes, games.*

## Media player

The media player works as a music player and video player all in one. You can play music and video clips that you receive in a picture message, or that you download to your phone. The following file types are supported by the media player: MP3, MP4, 3GP, AAC, AMR, MIDI, WAV (with 16 kHz as maximum sample rate) and Real®8. You can also stream music and videos from Web sites.

## Playlists

To organize the media files that are stored in the File manager you can create playlists. A playlist can contain music as well as video clips. Files in a playlist can be sorted by artist, title or by the order in which the files were added to the playlist. You can add a file to more than one playlist.

The playlists **All music** and **All videos** are automatically generated and contain all music and video files that are saved in the phone memory. You cannot delete or rename these playlists.



*When you delete a playlist or a file from the playlist, it is not deleted permanently from the phone memory. You can add the file to another playlist.*

### To create a playlist

- 1 ▶ Entertainment ▶ Media player ▶ New playlist enter the name of the playlist ▶ OK.
- 2 Select among the files that are available in the **File manager**. You can add several files at a time and you also add folders. All files in the selected folders will be added to the playlist.

### To add files to a playlist

- 1 ▶ Entertainment ▶ Media player select a playlist ▶ Open ▶ More ▶ Add media.
- 2 Select among the files that are available in the **File manager**.

### To remove files from a playlist

- ▶ Entertainment ▶ Media player select a playlist ▶ Open. Select the file ▶ More ▶ Delete.

### To delete playlists

- ▶ Entertainment ▶ Media player select a playlist ▶ More ▶ Delete playlist.

## Music and video clips

### To play music and videos







► Entertainment ► Media player and select a playlist  
 ► Open ► Play. The playlist keeps on playing until you ► Pause or Stop.

### To change play mode

► Entertainment ► Media player ► More ► Play mode. Select **Shuffle on** to play the playlist files in random order, or **Loop on** to restart the playlist when the last file has been played.

 You can also change the play mode from within the playlists.

### Media player control

- ► Pause to pause the playback.
- Press  or  to go forward or back to the next music track or video clip.
- Press and hold  or  to fast forward or rewind.
- Press  and  to scroll through the playlist during playback. Files that are highlighted will not be selected until you press ► Stop ► Play.
- When a video clip is paused, press  to play the video clip one frame at a time.

### Media player options

- More to view the following options:
- **Play mode** – change the playback order of songs and videos. Select **Loop** or **Shuffle**.
  - **Equalizer** – change the settings of the treble and bass when playing music.
  - **Rename** – rename the playlist. You can only rename user-created playlists.
  - **Delete playlist** – delete the playlist. Only the playlist is deleted; the files are still listed in the **File manager**. You can only delete user-created playlists.

### Media options

When you have opened a playlist, ► More to view the following options:

- **Information** – view information about the current track or video.
- **Add media** – add files or folders to the playlist.
- **Minimize** – minimize the media player and return to standby. The music or video continues to play and you can use other applications and functions in the phone.
- **Play mode** – change the playback order of songs and videos.

## Entertainment

- **Equalizer** – change the settings of the treble and bass when playing music.
- **Sort** – sort the playlist by artist, title or by the order in which files were added to the playlist.
- **Send** – send a sound or video file.
- **Delete** – remove the file from the playlist.
- **Fullscreen** – play the video clip in full screen and in horizontal mode.
- **Capture frame** – capture a picture from the video clip.





### Online music and videos

You can view videos and listen to music that you find on a Web site by streaming them to your phone. When browsing and when you have found a link for streaming, the media player will open automatically when the link is selected.

In order to stream you must have a data account and the links have to be 3GPP™ (3rd Generation Partnership Project) compatible. Your phone may be pre-configured with a data account. If it is not, please contact your network operator or visit [www.SonyEricsson.com/support](http://www.SonyEricsson.com/support). ➡ 61 Settings.

### To select a data account

- 1 ▶ **Settings** ▶ the **Connectivity** tab  
▶ **Streaming settings**. Use  or  to scroll between the tabs.
- 2 Select the data account you want to use.

### To stream video and audio

- 1 ▶ **Internet services** ▶ **More** ▶ **Enter address**.
- 2 Enter or choose the address to a site and select a link to stream from.

### To stream saved music and videos

- 1 ▶ **Internet services** ▶ **More** ▶ **Bookmarks**.
- 2 Select a link to stream. The media player will open and play the streamed music or video.

## Radio





Your phone features an FM radio with RDS functionality. To use the radio, you must connect the handsfree to your phone. The handsfree works as an antenna and makes the reception better. The radio can be used as an alarm signal, ➡ 71 Alarm clock

 You must switch your phone on to use the radio. Do not switch the phone on in areas where mobile phones are prohibited, ➡ 85 Guidelines for Safe and Efficient Use.

### To listen to the radio

Connect the handsfree to your phone ► **Radio**.

### Radio control

- ► **Search** to find the next channel on the band.
- Press  or  to move 0.1 MHz along the FM band. Press and hold to move continuously.
- Press  or  for the next preset channel.

### Saving radio channels

You can save up to 20 of your favourite radio channels.

 To save channels quickly in positions 1 to 10, press and hold 0–9, (where 0 represents the number 10). To select a channel you have saved in positions 1 to 10, press 0–9.

### To save a radio channel

► **More** ► **Save** ► **Insert**. The channel is saved in a list.

### Radio options

► **More** for the following options:

- **Minimize** – return to standby to use other functions with the radio still playing.
- **Save** – save the current frequency in a list of channels.
- **Channels** – select, rename, replace or delete saved channels.
- **Turn on speaker** – listen through the loudspeaker.
- **Auto save** – automatically search for and save channels in a list of channels. Previously saved channels will be replaced.
- **Set frequency** – enter a frequency manually. The figures you enter will be automatically adjusted to valid frequencies. Press  to go directly to **Set frequency**.
- **RDS** – options to turn on or off alternative frequency (AF) and to show or hide station information.
- **Turn on Mono** – turn mono sound on.

### While listening to the radio

If you minimize the radio display, you can listen to the radio and use another functionality at the same time. For example, you can make and receive calls, send messages and play games.

### **To minimize the radio display**

► Radio ► More ► Minimize.

### **To adjust the volume**

Press  or .

## **t-music**

This function is a mobile online service from T-Mobile. Please visit [www.t-mobile.net](http://www.t-mobile.net) for further information about Mobile Jukebox and t-music.



 *The service may not always be available in all countries or when you are using a network other than your network operator's – a message will appear to inform you about this when selecting the t-music icon.*

## **Ringtones and melodies**

Your phone comes with a number of standard and polyphonic melodies that can be used as ringtones. You can exchange melodies using one of the available transfer methods. Please note that you are not allowed to exchange copyright-protected material. You can also record a sound and use it as a ringtone, ► 59 *To start a sound recording.*

 *If you select an MP3 file as a ringtone, you cannot use voice answering, ► 30 *Voice answering.**





### **To select a ringtone**

► Settings ► the Sounds & alerts tab ► Ringtone. Use  or  to scroll between the tabs.

### **To turn the ringtone on or off**

Press and hold  from standby. All signals except the alarm signal are turned on or off.

### **To set the ringtone volume**

- 1 ► Settings ► the Sounds & alerts tab. Use  or  to scroll between the tabs.
- 2 ► Ring volume and press  or  to decrease or increase the volume.
- 3 ► Save to save the setting.

### **Caller-specific ringtones**

If your subscription includes the Calling Line Identification (CLI) service, you can assign a personal ringtone to callers, ► 25 *To add a picture or a ringtone to a phone contact.*



### **Vibrating alert**

You can choose to be notified of an incoming call by the buzzing of the vibrating alert. You can set:

- On – all the time.
- On if in Silent – on when the ring volume is turned off or when you have set the phone to silent.
- Off – all the time.



**To set the vibrating alert**

Settings ► the Sounds & alerts tab ► Vibrating alert and select the setting you want. Use  or  to scroll between the tabs.

**Sounds and alerts options**





From Settings and the Sounds & alerts tab, you can set:

- **Message alert** – select how you want to be notified of an incoming message.
- **Key sound** – select what sound you want the keys to make when you press them.

**MusicDJ™**

You can compose and edit melodies to use as ringtones using the MusicDJ™. A melody consists of four types of tracks – **Drums**, **Basses**, **Chords**, and **Accents**. A track contains a number of music blocks. The blocks consist of pre-arranged sounds with different characteristics. The blocks are grouped into **Intro**, **Verse**, **Chorus** and **Break**. You compose a melody by adding music blocks to the tracks.

**To compose a melody**

- 1 ► Entertainment ► MusicDJ™.
- 2 Choose to **Insert**, **Copy** and **Paste** blocks to compose your melody. Use , ,  or  to move between the blocks. Press  to delete a block. ► **More** to view more options.

**To edit a previously created melody**

- File manager ► Sounds and select the melody
- More ► Edit.

**Sending and receiving**

You can send and receive melodies using one of the available transfer methods. Please note that you are not allowed to exchange copyright-protected material.



*You cannot send a polyphonic melody or an MP3 file in a text message.*

**To send a melody**

- 1 ► File manager ► Sounds and select a melody.
- 2 ► More ► Send and select a transfer method.

### **To receive a melody**

- 1 Open the message you received the melody in, or turn on Bluetooth or the infrared port if these transfer methods are being used to send the melody.
- 2 When you receive the melody, follow the instructions that appear on the screen.

### **VideoDJ™**

With the VideoDJ™, you can create movies by combining video clips and pictures that you have saved in your phone. You can also use VideoDJ™ to trim video clips and edit video items.

### **To create a movie**

- 1 ▶ Entertainment ▶ VideoDJ™.
- 2 ▶ Add. Select to add a Video clip, a Picture or Text ▶ Select.

### **To edit a video clip**

- 1 ▶ File manager ▶ Videos ▶ Open and choose the video clip you want to open.
- 2 ▶ More ▶ Edit ▶ Edit to Trim, Replace or Delete a clip from the current movie.

### **To edit a picture**

- 1 ▶ Entertainment ▶ VideoDJ™.
- 2 ▶ Add ▶ Picture. Choose the picture you want to edit and ▶ Select.
- 3 ▶ Edit.
- 4 ▶ Replace to replace a picture, ▶ Duration to change the picture duration in the movie or ▶ Delete to delete the picture from the current movie.

### **To edit text**

▶ Edit to change a text string, ▶ Background to change the text background, ▶ Text colour to change the font colour, ▶ Duration to change the duration of the text in the movie or ▶ Delete to delete the text from the current movie.

### **VideoDJ™ options**

When a movie is selected, ▶ More to view more options:

- Preview – to view the movie.
- Insert – to insert an item.
- Save – to save the current movie.
- Send – to send the current movie.
- New – to open another movie.
- Soundtrack – to add a soundtrack to the current movie.

## Sending and receiving movies

You can send a movie using one of the available transfer methods. Short movies can be sent using picture messaging. If a movie is too long, you can use the **Trim** function to make a movie shorter.

Movies that you receive and save are saved in the file manager.

### To trim a video clip

- 1 Select a video from the storyboard ► **Edit**  
► **Trim**.
- 2 ► **Set** to set the start point and ► **Start**.
- 3 ► **Set** to set the end point and ► **End**.
- 4 You can repeat steps 2 and 3 until you are satisfied. ► **Done** to finish the trim.

## Sound recorder

With the sound recorder, you can record either your own memos or calls. Recorded sounds can also be set as ringtones. Recording of a conversation is stopped if a participant ends the call. Recording of all sounds stops automatically if you receive a call. If the recordings are saved in the phone they can be accessed even if you change your SIM card.

 *In some countries or states it is required by law that you inform the other person before recording the call.*

### To start a sound recording

- 1 ► **Entertainment** ► **Record sound**.
- 2 Wait until you hear a tone. When the recording starts, **Recording** is displayed together with the time of the current recording (increasing).
- 3 ► **Save** to end the recording, and ► **Play** to listen to the recording. ► **More** to view the following options: **Record new**, **Send**, **Rename**, **Delete**, **Recorded sounds**.

### To listen to your recordings

- 1 ► **File manager** ► **Sounds** and select the recording you want to hear.
- 2 ► **Play** to listen to the recording and ► **Stop** to stop playback.

## Themes

You can change the appearance of the screen, for example, the colours and wallpaper, by using themes. Your phone comes with some predefined themes. You cannot delete these, but you can create new themes and download them to your phone. For more information, visit [www.SonyEricsson.com/support](http://www.SonyEricsson.com/support).

## Entertainment

### **To select or change a theme**

- ▶ File manager ▶ Themes and select a theme.

### **Exchanging themes**

You can exchange themes using one of the available transfer methods.

### **To send a theme**

- ▶ File manager ▶ Themes and select a theme.
- ▶ More ▶ Send and select a transfer method.

### **To receive and save a theme**

- Open the message you received the theme in, or turn on Bluetooth or the infrared port if these transfer methods are being used to send the theme.
- When you receive the item, follow the instructions that appear on the screen.

### **To download a theme**

- ▶ File manager ▶ Themes ▶ Sony Ericsson.

## Games

Your phone has several entertaining games. You can also download games and applications directly to the folders in your phone. Help texts are available for most games.

### **To start and end a game**

- ▶ Entertainment ▶ Games and select a game  
▶ Select.
- Press and hold  to end the game.

### **To download a game**

- ▶ Entertainment ▶ Games ▶ Sony Ericsson.

## Connectivity

*Internet and email settings, browsing, synchronizing, Bluetooth, infrared, USB cable.*



### Settings

Before you start using Internet or messaging, settings are required in your phone.

Settings may already be entered when you buy your phone. If not, contact your network operator or service provider for more information. Settings are also available at [www.SonyEricsson.com/support](http://www.SonyEricsson.com/support).

In order to use the Internet, and send and receive picture and email messages, you need the following:

- A phone subscription that supports data transmission.
- Settings entered in your phone.
- You may also have to register as an Internet and email user with your network operator or service provider.

### Entering Internet and email settings



If the settings are not already entered in your phone, you can:

- Receive settings from your network operator or service provider. Settings are also available at [www.SonyEricsson.com/support](http://www.SonyEricsson.com/support).
- Enter or edit settings manually.

### Using Internet

Your phone has a browser that uses WAP (Wireless Application Protocol) or HTTP (Hyper Text Transfer Protocol) to access the Internet.

#### **To select an Internet profile**

► Settings ► the Connectivity tab ► Internet settings ► Internet profiles and select the profile you want to use. Use  or  to scroll between the tabs.

#### **To start browsing**

► t-zones and select a service or ► t-zones ► More and select an option.

#### **To stop browsing**

► More ► Exit browser.

## Connectivity

### Options when browsing

► **More** to view different browsing options. The options may vary depending on which site you are visiting.



*If you select an email address when browsing a Web site, you can send a text message to that address.*

The options menu always contains the following:

- **Exit browser** – disconnect and go to standby. A list of ongoing or suspended downloads may be shown.
- Go to the homepage set for the current Internet profile, for example, **Sony Ericsson**.
- **Bookmarks** – add the site you are currently browsing to your list of bookmarks, or view the list of bookmarks.
- **Enter address** – enter the Web page address of a site you want to visit. ► **New address** to enter a new Web page address or select one of the 10 latest entered addresses. When you enter a Web page address, the normal http:// prefix is not needed.
- **History** – list of previously visited sites.
- **Refresh page** – refresh the contents of the Web page.

- **Save** – save the Web page or a picture from the current Web page.
- **Send link** – send a link to the current site to another phone.
- **Appearance** – select to play the sounds or show the pictures on visited pages.
- **Clear cache** – clear all temporary stored Internet files saved in the phone.
- **Status** – display current status information, for example, profile, access type, security, address.
- **Make a call** – if your subscription supports it, you can make a call while browsing the Internet. ► **More** ► **End call** to end the call and continue browsing.

### Using bookmarks

You use bookmarks in your mobile phone just as you do with a computer Internet browser. You can create and edit bookmarks.

#### To work with bookmarks

- 1 ► **t-zones** ► **More** ► **Bookmarks** and select a bookmark ► **More**.
- 2 Select an option.

## Downloading

You can download, for example, pictures, themes, games and ringtones from Web sites directly to the File manager in your phone.

### To download from t-zones

- ▶ t-zones ▶ More ▶ Bookmarks.
- Select the service you want to use and follow the instructions that appear.

## Stored information



When browsing, you can save information in your phone.

 *It is advisable to clear any sensitive information about previously visited Internet services. This is to avoid a security risk if your phone is misplaced, lost or stolen.*



The following information can be saved:

- Cookies – improve site access efficiency.
- Passwords – improve server access efficiency.

### To allow or clear cookies in your phone

- ▶ Settings ▶ the Connectivity tab ▶ Internet settings
- ▶ Cookies and select an option and confirm. Use  or  to scroll between the tabs.

### To clear the password list



- ▶ Settings ▶ the Connectivity tab ▶ Internet settings
- ▶ Clear passwords and ▶ Yes to confirm. Use  or  to scroll between the tabs.

### Internet profile for Java™ applications

Some Java™ applications need to connect to the Internet to receive information, for example, games that download new levels from a game server.

You need an HTTP Internet profile to allow Java™ applications to connect to the Internet. Please contact your network operator or service provider for the correct settings.

### To select a profile for Java™

- ▶ Settings ▶ the Connectivity tab  
▶ Settings for Java™ ▶ Internet profiles.  
Use  or  to scroll between the tabs.
- Select the HTTP profile you want to use.

### Internet security



Your phone has support for both WAP and HTTP secure browsing. To activate a secure connection to the WAP gateway, you need to turn on security in your Internet profile. If your Internet profile is an

## Connectivity

HTTP profile, the connection will be secure if the URL starts with https://. The security setting is therefore not available for HTTP profiles.

 *Security for a connection between a WAP gateway and a WAP service provider is the responsibility of the WAP service provider.*

### **To turn on a secure connection (WAP)**



- 1 ▶ **Settings** ▶ the **Connectivity** tab ▶ **Internet settings** ▶ **Internet profiles** and select a profile ▶ **More** ▶ **Settings**. Use  or  to scroll between the tabs.
- 2 Turn on security.

### **Trusted certificates**

To establish a secure connection when using certain Internet services, for example, banking, you need certificates in your phone.

Trusted certificates are used to verify the WAP gateway or the HTTP server that you are connecting to. Your phone may already contain trusted certificates when you buy it. You can also download new certificates using the browser.

### **To check the certificates in your phone**

▶ **Settings** ▶ the **Connectivity** tab ▶ **Internet settings** ▶ **Security** ▶ **Trusted cert.** Use  or  to scroll between the tabs.

## Synchronizing

You can synchronize your phone contacts, appointments, tasks and notes with similar programs in, for example, a computer or mobile phone using Bluetooth, the infrared port or the USB cable (synchronization with nearby devices). Synchronization software for your computer is available on the CD that comes with the phone, or you can download it from [www.SonyEricsson.com/support](http://www.SonyEricsson.com/support).

You can also synchronize with programs on the Internet using WAP or HTTP (remote synchronization with Internet services).

 *When using USB, make sure you only use the USB cable that comes with the phone.*

### **To select sync order for names**

▶ **Contacts** ▶ **Options** ▶ **Advanced** ▶ **Sync. order** to select the order in which first and last name appear in the phone when you synchronize contacts.



### Synchronization with nearby devices

Install the computer synchronization software from the CD that comes with your phone or download it from [www.SonyEricsson.com/support](http://www.SonyEricsson.com/support). For detailed information, please refer to the computer synchronization software help.

### Remote synchronization with Internet programs

Contact your network operator for more information about the programs on the Internet with which you can synchronize, and to receive username, password and addresses for the different programs. You must also have an Internet profile set in your mobile phone ➤ *61 Settings*.

### To enter the remote synchronization settings

- 1 ▶ **Organizer** ▶ **Synchronization** ▶ **New account**.  
If you do not have an account, you will be asked if you want to create an account. ▶ **Yes** to create a new account.
- 2 Enter a name for the new account ▶ **Continue**.  
A list of items to enter will appear. Add the server address of the synchronization server, a server username and a server password. ▶ **OK** when you have entered each setting.

- 3 ▶ **Connection** and select the WAP or HTTP profile that you want to use for the synchronization.
- 4 ▶ **Remote initiation** to set whether to allow the synchronization server or other device to initiate a synchronization or not. You can also choose to always be asked.
- 5 ▶ **Sync. interval** to set how often you want the phone to automatically connect to the server and start synchronization.
- 6 ▶ **Applications** and select the applications that you want to synchronize, for example, **Contacts** ▶ **OK**.
- 7 ▶ **App. settings** and select an application. Enter the name of the database and, if required, your username and password ▶ **OK**.
- 8 Press  ▶ **Save** to save your new account.

### To start the remote synchronization

- ▶ **Organizer** ▶ **Synchronization** and select a remote account ▶ **Start**.

### Bluetooth™ wireless technology

Your phone has built-in Bluetooth which makes it possible for you to connect your phone wirelessly to other Bluetooth devices. You are able to be connected to several Bluetooth devices at the same time. You can automatically synchronize information in your phone and your computer and use the remote control functionality to control applications on your computer. You can also exchange, for example, business cards, calendar items and pictures.

 *We recommend that your phone and the Bluetooth device you are communicating with are within a range of 10 metres. The connection may be improved if there are no solid objects between your phone and the other Bluetooth device.*

#### Before you start

To communicate with another Bluetooth device, you first need to turn Bluetooth on. You then need to add the device to the list of devices in your phone. You can exchange items, use a remote screen and play games without adding the device to the list. To synchronize with your computer and browse the Internet, you also need to install software on

your computer from the CD that comes with your phone, or download it from [www.SonyEricsson.com/support](http://www.SonyEricsson.com/support).



➔ 64 Synchronizing.

 *Please check if local laws or regulations restrict the use of Bluetooth. If Bluetooth is not allowed, you must ensure that the Bluetooth function is turned off. The maximum allowed Bluetooth radio output power in the phone is automatically adjusted according to possible local restrictions. This means that the range may vary.*

#### To turn Bluetooth on

▶ Settings ▶ the Connectivity tab ▶ Bluetooth  
▶ Turn on. Use  or  to scroll between the tabs.

#### To add a device to your phone

- ▶ Settings ▶ the Connectivity tab. Use  or  to scroll between the tabs.
- ▶ Bluetooth ▶ My devices ▶ New device. The Bluetooth function of the other device must also be on and not hidden.
- ▶ Add and your phone will search for all types of available Bluetooth devices.
- A list of available devices is displayed. Select a device.

- 5 If the device you are adding to your phone has its own passcode, enter this passcode in your phone. If not, create a passcode of digits yourself and enter it in both devices.

### **To organize your list of devices**

- 1 ▶ Settings ▶ the Connectivity tab ▶ Bluetooth ▶ My devices and select a device from the list. Use ⌚ or ⌚ to scroll between the tabs.
- 2 ▶ More to view a list of options.

### **Power save**

You can choose to turn this feature on or off if you do not want to use several Bluetooth functions at the same time. If you turn it on, the phone will save power and it will prevent other devices from connecting to your phone when you are already connected to one.

### **To save power**

- ▶ Settings ▶ the Connectivity tab ▶ Bluetooth
- ▶ Power save ▶ On. Use ⌚ or ⌚ to scroll between the tabs.

### **Phone name**

Choose a unique name for your phone. This name is shown in other devices when your phone is found.

### **To enter a phone name**

- ▶ Settings ▶ the Connectivity tab ▶ Bluetooth
- ▶ Phone name. Use ⌚ or ⌚ to scroll between the tabs.

### **Visibility**

In order for your phone to be found when searched for by other Bluetooth devices, you must make sure that Bluetooth is turned on and your phone is visible to other devices.

### **To hide or show your phone when using Bluetooth**

- 1 ▶ Settings ▶ the Connectivity tab ▶ Bluetooth ▶ Visibility. Use ⌚ or ⌚ to scroll between the tabs.
- 2 ▶ Show phone or Hide phone.

### **Sending and receiving**

To send or receive an item using Bluetooth, you need to make sure that the devices are within range.



After you select Bluetooth as the transfer method for sending, a list of possible receiving devices is presented.

## Connectivity



### **To send an item (example: a contact)**

- 1 ▶ **Contacts** and select a contact, ▶ **More**  
▶ **Send contact** ▶ **Via Bluetooth**. The phone searches for devices.
- 2 Select the device you want to send the item to ▶ **Select**.

### **To receive an item**

- 1 ▶ **Settings** ▶ the **Connectivity** tab. Use  or  to scroll between the tabs.
- 2 ▶ **Bluetooth** ▶ **Turn on**.
- 3 Make sure that your phone is visible to other devices **Bluetooth** ▶ **Visibility** ▶ **Show phone**. When you receive the item, follow the instructions that appear on the screen.

### **To add a Bluetooth handsfree to your phone**

- 1 ▶ **Settings** ▶ the **Connectivity** tab ▶ **Bluetooth** ▶ **Handsfree**. Use  or  to scroll between the tabs.
- 2 The first time you add a handsfree, **Add a handsfree device to use with the phone?** is displayed ▶ **Yes**.

- 3 If you already have a handsfree in your list of devices, ▶ **Settings** ▶ the **Connectivity** tab ▶ **Bluetooth** ▶ **Handsfree** ▶ **My handsfree** ▶ **New handsfree** ▶ **Add**. You should ensure that your Bluetooth handsfree is in pairing mode.

### **Transferring sound**

When you are using a Bluetooth handsfree with your phone, you can choose to transfer the sound either to the phone or to another handsfree device that has been added to your phone.



#### **To transfer sound when using a handsfree**

During a call, press  ▶ **Transfer sound**.

### **Directing sound**

You can select where the sound should be handled when answering an incoming call with the keypad on the phone. If you use the button on the handsfree, the sound will always be in the handsfree.

#### **To direct sound when answering a call with a handsfree**

- 1 ▶ **Settings** ▶ the **Connectivity** tab ▶ **Bluetooth** ▶ **Handsfree** ▶ **Incoming call**. Use  or  to scroll between the tabs.

- 2** ▶ **In phone** if you always want to have the sound in the phone or **In handsfree** if you want to direct the sound to the handsfree.

### Remote control

You can use your phone as a remote control device to control computer applications such as a media player or Microsoft® PowerPoint® presentations. Your computer must support the Bluetooth HID Profile.

#### To select remote control

- ▶ **Entertainment** ▶ **Remote control**.
- Select the application you want to use and the computer you want to connect to.

### File transfer using Bluetooth

You can use a computer to view and transfer content in the file manager. Install the File manager software using the CD that comes with your phone, or download the software from [www.SonyEricsson.com/support](http://www.SonyEricsson.com/support). You can use the drag-and-drop function of your computer to:

- Transfer files between your phone and the computer.
- Delete files.



 *Your computer needs to have one of the following operating systems to be able to use this feature: Windows® 2000, Windows ME, Windows XP and Mac OS X.*

### Infrared port

You can use the infrared port to establish contact between your phone and a computer or another device equipped with an infrared port. You can, for example, synchronize calendar items,  *64 Synchronizing*, transfer files between your phone and a computer, and send items such as pictures and contacts.

 *If you are connecting to a computer, please refer to its user documentation. Make sure that the infrared speed in the computer is set to 115200 bps.*

#### To turn the infrared port on

- ▶ **Settings** ▶ the **Connectivity** tab. Use  or  to scroll between the tabs.
- ▶ **Infrared port** ▶ **On** or ▶ **10 minutes** to turn on infrared for 10 minutes only.

## Connectivity

### To connect two devices

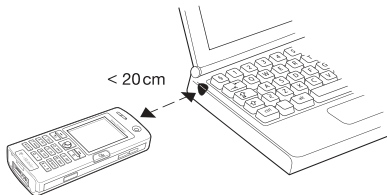

- 1 Turn on the infrared port of both devices.
- 2 Make sure that the infrared port on your phone faces the infrared port on the other device.
- 3 Your phone now establishes contact with the other device.

### To send an item using the infrared port (example: a contact)

- 1 Make sure that the infrared ports of both devices are on. ► **Contacts** and select a contact.
- 2 ► **More** ► **Send contact** ► **Via infrared**.

### File transfer using the infrared port

► 69 *File transfer using Bluetooth* on how to transfer files between your phone and a computer.

💡 Your computer needs to have one of the following operating systems to be able to use this feature:  
*Windows® 2000, Windows ME, Windows XP and Mac OS X.*

### The USB cable

You can connect your phone to a computer using the USB cable. Install the USB cable software using the CD that comes with your phone, or download the drivers from [www.SonyEricsson.com/support](http://www.SonyEricsson.com/support).

💡 Make sure you use only the USB cable that comes with the phone, and that you connect the USB cable direct to your computer.

### File transfer using the USB cable

► 69 *File transfer using Bluetooth* on how to transfer files between your phone and a computer.

💡 Your computer needs to have one of the following operating systems to be able to use this feature:  
*Windows® 2000, Windows ME and Windows XP.*

To synchronize your phone with nearby devices  
► 64 *Synchronizing*.

## More features

*Time and date, alarm clock, calendar, tasks, Java™ applications, SIM card lock, etc.*

### Time and date

The time is always displayed in standby.

- To set the time ► **Settings** ► the **General** tab ► **Time & date** ► **Time**. Enter the time ► **Save**.
- To set the time format ► **Format** and select an option.
- To set the date and date format ► **Settings** ► the **General** tab ► **Time & date** ► **Date**.

### Alarm clock

The alarm can be set to ring at a specific time within 24 hours, or recurrently at a specific time on several days. You can have both these alarms set at the same time. The alarm signal rings even if the phone is set to silent or turned off. The alarm can use the radio as an alarm signal.

#### **To set an alarm**

- **Organizer** ► **Alarms** ► **Alarm** and enter the time
- **Save**.

### Using the alarm

- To change the alarm time ► **Organizer** ► **Alarms** ► **Alarm** and enter a new time.
- To turn the alarm signal off when it rings, press any key (if radio is selected as alarm signal ► **Snooze**). If you do not want the alarm to be repeated ► **Turn off**.
- To cancel the alarm ► **Organizer** ► **Alarms** ► **Alarm** ► **Turn off**.
- To set a recurrent alarm ► **Organizer** ► **Alarms** ► **Recurrent alarm**. Enter the time ► **Continue** and select the days that you want the alarm to recur on by scrolling and pressing **Mark**. ► **Done** to exit the menu.
- To select an alarm signal ► **Organizer** ► **Alarms** ► **Alarm signal**. Select **Radio** or **Sounds**.



*If you choose Radio as the alarm signal, please make sure that the handsfree is connected to the phone.*

### Calendar

You can use the calendar to keep track of important meetings. The calendar can be synchronized with a computer calendar or with a calendar on the Web, ► **64 Synchronizing**.

## More features

### Appointments

You can choose to add a new appointment or use an old one as a template by copying and editing it. You can also set reminders for appointments.

#### To add a new appointment

- 1 ▶ Organizer ▶ Calendar and highlight the date for the appointment ▶ Select ▶ New appointment ▶ Add.
- 2 Enter details and confirm each entry.

#### To view an appointment

- 1 Organizer ▶ Calendar and select a day on which you have an appointment (marked in bold).
- 2 Scroll to the appointment ▶ View.

#### To view your calendar content

▶ Organizer ▶ Calendar. Days on which you have appointments are marked in bold. ▶ More ▶ View week to view a certain week.

#### To set when reminders should sound

- 1 ▶ Organizer ▶ Calendar ▶ More ▶ Advanced ▶ Reminders.

- 2 ▶ Always if you want the reminder to sound even though the phone is turned off. When the reminder sounds ▶ Yes to read the appointment. ▶ No to turn off the reminder. A reminders option set in the calendar affects a reminders option set in tasks.

### Navigating in your calendar

Use the navigation key to move between days or weeks. In the monthly and weekly views, you can also use the keypad as follows:

---

<input type="button" value="1"/> Back a week	<input type="button" value="3"/> Next week
<input type="button" value="4"/> Back a month	<input type="button" value="6"/> Next month
<input type="button" value="7"/> Back a year	<input type="button" value="9"/> Next year
<input type="button" value="C"/> Today's date	

---

### Calendar settings

- ▶ Organizer ▶ Calendar ▶ More and select an option.
- **View week** – select, add, edit or delete appointments.
  - **New appointment** – add a new appointment.
  - **Change date** – change the date of your calendar.
  - **Advanced** – for options to find, delete all, set reminders or select a start day for the week.



## Exchanging appointments

You can send and receive appointments using one of the available transfer methods.

### To send an appointment

In the list of appointments for a certain day, select the item you want to send ► **More** ► **Send** and select a transfer method.

## Tasks

You can keep track of phone calls you need to make or tasks that you need to do. You can choose to add a new task or use an old one as a template by copying and editing it. You can also set a reminder for a task.

### To add a new task

- 1 ► **Organizer** ► **Tasks** ► **New task** ► **Add**.
- 2 Select a category. If the category is a phone call, enter the phone number ► **Continue**.
- 3 Enter a subject ► **Continue**.
- 4 If you want to set a reminder for your task ► **Yes**.

### To view a task

► **Organizer** ► **Tasks** and select a task ► **View**.

### To set when reminders should sound

- 1 ► **Organizer** ► **Tasks** and select a task ► **More** ► **Reminders**.
- 2 ► **Always** if you want the reminder to sound even though the phone is turned off. When the reminder sounds ► **Yes** to read the task, or to call the phone number in a phone task. ► **No** to turn off the reminder. A reminders option set in tasks affects a reminders option set in the calendar.

## Exchanging tasks

You can send and receive tasks using one of the available transfer methods. You can also synchronize tasks with a computer, ► *64 Synchronizing*.

### To send a task

- 1 In the list of tasks for a certain day, select the item you want to send ► **More** ► **Send**.
- 2 Select a transfer method.

## Notes

If you need to remember something, you can make a note of it in your phone.

## More features

### **To add a note**

► Organizer ► Notes ► New note ► Add and enter the note ► Save.

### **To handle notes**

- 1 ► Organizer ► Notes and a list of notes appears.
- 2 Select the note that you want to handle. ► More to edit, show a note in standby (or hide it), send or delete a note.

### **Exchanging notes**

You can send and receive notes using one of the available transfer methods. You can also synchronize notes with a computer, ➤ 64 *Synchronizing*.

### **To send a note**

► Organizer ► Notes and select the note that you want to send ► More ► Send and select a transfer method.

## **Profiles**

Your phone has predefined profiles that are set to suit a certain environment. You can reset all profile settings to the way they were set when you bought your phone.

### **To select a profile**

► Settings ► the General tab ► Profiles  
► Select profile.

### **To change a profile setting**

► Settings ► the General tab ► Profiles ► Edit profile and select the setting that you want to change.

### **To rename a profile**

► Settings ► the General tab ► Profiles ► Edit profile ► Profile name. You cannot rename the normal profile.

## **Stopwatch**

Your phone has a stopwatch that can save several laps. The stopwatch continues to run when you answer an incoming call.

### **To use the stopwatch**

- 1 ► Organizer ► Stopwatch ► Start.
- 2 ► Stop or ► New lap if you want a lap time.
- 3 To reset the stopwatch ► Reset.

## Timer



### To set the timer

► **Organizer** ► **Timer** and enter the hours, minutes and seconds after which you want the timer to go off. When the signal rings, press any key to turn it off.

## Brightness

You can adjust the brightness of the screen.

### To set the brightness



► **Settings** ► the **Display** tab ► **Brightness**. Use  or  to scroll between the tabs.



## Start-up screen

When you turn your phone on, the start-up screen appears. You can also set your own start-up screen.

### To select a start-up screen

► **Settings** ► the **Display** tab ► **Start-up screen** and select an option for the start-up screen. Use  or  to scroll between the tabs.

## Start-up menu

When the start-up menu is activated, you can select to listen to music only instead of using the phone with full functionality. All transmitters of the phone are then turned off in order not to disturb sensitive equipment, for example, in an aeroplane or in a hospital. You cannot make or receive any calls, send messages etc. You can use the media player only.

### To activate the start-up menu

- **Settings** ► the **General** tab ► **Start-up menu**.
- Select **Show**.
- Turn off the phone.
- Turn on the phone. Two options appear.
- Select **Music only** to start using the media player. If you want to use the phone with full functionality, select **Start phone**.

### To deactivate the start-up menu

► **Settings** ► the **General** tab ► **Start-up menu**. Select **Don't show**.



*If you have selected Music only, you can still receive calendar and task reminders, and the alarm signal can still ring.*





## More features

### Calculator

The calculator can add, subtract, divide and multiply.

#### **To use the calculator**

► Organizer ► Calculator.

- Press  or  to select  $\div$   $\times$   $+$   $.$   $\%$   $=$ .
- Press  to delete the figure.
- Press  to enter a decimal point.

### Java™ applications

You can run Java™ applications on your phone. Games and other Java applications can be downloaded to your phone from the Internet.

#### **Java application security**

Java applications are automatically installed as “Trusted” or “Untrusted”. Trusted applications are allowed to, for example, connect to networks, send messages or use the camera without asking for permission. Untrusted applications, however, must always confirm such actions with you first. You can set different permission levels for your Java applications.

#### **To set permissions for a Java™ application**

- 1 ► File manager ► Applications or ► Games.
- 2 Select an application or a game ► More ► Permissions.
- 3 Select one of the listed options.
- 4 ► No, Always ask or Ask once to set the permission level you want for the selected application.

#### **Java application screen size**

Some Java applications are designed for a specific screen size. In some cases, applications may not be able to start because the phone cannot adapt the application to the screen. Contact the application vendor to find out what screen size the application is designed for, and change the screen settings for the application in the phone.

#### **To set the screen size for a Java application**

- 1 ► File manager ► Applications or ► Games.
- 2 Select an application or a game ► More ► Screen size.
- 3 Select one of the listed options. If you selected **User defined** you can edit the **Width:** and **Height:** values.

## SIM card lock

The SIM card lock protects your subscription, but not your phone itself, from unauthorized use. If you change SIM cards, your phone still works with the new SIM card.

Most SIM cards are locked at the time of purchase. If the SIM card lock is on, you have to enter a PIN (Personal Identification Number) every time you turn on your phone.

If you enter your PIN incorrectly three times in a row, the SIM card is blocked. This is indicated by the message **PIN blocked**. To unblock it, you need to enter your PUK (Personal Unblocking Key). Your PIN and PUK are supplied by your network operator. You can edit your PIN and select a new four- to eight-digit PIN.

 *If the message **Codes do not match** appears when you edit your PIN, you entered the new PIN incorrectly. If the message **Wrong PIN** appears, followed by **Old PIN:**, you entered your old PIN incorrectly.*

### To unblock your SIM card

- 1 When **PIN blocked** is displayed, enter your PUK ► OK.
- 2 Enter a new four- to eight-digit PIN ► OK.
- 3 Re-enter the new PIN to confirm ► OK.

### To edit your PIN

- 1 ► Settings ► the General tab ► Locks ► SIM lock ► Change PIN.
- 2 Enter your PIN ► OK.
- 3 Enter a new four- to eight-digit PIN ► OK.
- 4 Re-enter the new PIN to confirm ► OK.

### To turn the SIM card lock on or off

- 1 ► Settings ► the General tab ► Locks ► SIM lock ► Protection and select On or Off.
- 2 Enter your PIN ► OK.

## Keypad lock

You can lock the keypad to avoid dialling a number by accident.

 *Calls to the international emergency number 112 can still be made, even when the keypad is locked.*

### Automatic keylock

In standby, automatic keylock means the keypad is locked a short while after you last press a key.

### To set the automatic keylock

- Settings ► the General tab ► Locks ► Automatic keylock.

## More features

### **To lock the keypad manually**

In standby press  ► **Lock keys**.

You can still answer an incoming call and the keypad locks again after the call. The keypad remains locked until you unlock it manually.

To unlock the keypad, press  ► **Unlock**.

### **Phone lock**

The phone lock protects your phone against unauthorized use if it is stolen and the SIM card is exchanged. You can change the phone lock code (0000) to any four- to eight-digit personal code.

### **Automatic phone lock**

If the phone lock is set to automatic, you do not need to enter your phone lock code until a different SIM card is inserted in the phone.

 *It is important that you remember your new code. If you should forget it, you have to hand in your phone to your local Sony Ericsson retailer.*

### **To set the phone lock**

- 1 ► **Settings** ► the **General** tab ► **Locks** ► **Phone lock** ► **Protection** and select an alternative.
- 2 Enter the phone lock code ► **OK**.

### **To unlock the phone**

If the phone lock is on, enter your code ► **OK**.

### **To edit your phone lock code**

- **Settings** ► the **General** tab ► **Locks** ► **Phone lock**
- **Change code**.

### **Code memo**

Instead of having to remember security codes for credit cards, for example, you can save them in the code memo in your phone. All you need to remember is the passcode to open the code memo.

### **Checkword and security**

To confirm that you have entered the correct passcode for the code memo and to prevent unauthorized access to your codes, you must enter a checkword.

When you enter your passcode to open the code memo, the checkword is shown for a short time. If the passcode is correct, the correct codes are shown. If you enter the incorrect passcode, the checkword and the codes that are shown are also incorrect.

**To open code memo for the first time**

- 1 ▶ **Organizer** ▶ **Code memo**. A message with instructions is displayed ▶ **Continue**.
- 2 Enter a four-digit passcode to open code memo ▶ **Continue**.
- 3 Re-enter the new passcode to confirm.
- 4 Enter a checkword (maximum 15 characters) ▶ **Done**. The checkword can consist of both letters and numbers.

**To add a new code**

- 1 ▶ **Organizer** ▶ **Code memo** and enter your passcode ▶ **New code** ▶ **Add**.
- 2 Enter a name associated with the code, ▶ **Continue**.
- 3 Enter the code ▶ **Done**.

**To change the passcode**

- 1 ▶ **Organizer** ▶ **Code memo** and enter your passcode ▶ **More** ▶ **Change passcode**.
- 2 Enter your new passcode ▶ **Continue**.
- 3 Re-enter the new passcode ▶ **Continue**.
- 4 Enter a checkword ▶ **Done**.

**Forgot your passcode?**

If you forget your passcode, you must reset the code memo.

**To reset code memo**

- 1 Enter any passcode to access the code memo function. The checkword and codes that are then shown are incorrect.
- 2 ▶ **Organizer** ▶ **Code memo** ▶ **More** ▶ **Reset**.
- 3 **Reset code memo?** is displayed ▶ **Yes**. The code memo is reset and all entries are cleared. The next time you enter the code memo, you must start by opening the code memo for the first time.

### Troubleshooting

*Why doesn't the phone work the way I want?*

This chapter lists some problems that you might encounter while using your phone. Some problems require you to call your network operator, but you can easily correct most of the problems yourself.

However, if you need to hand in your phone for repair, please note that you may lose information and content that you have saved in your phone. You are advised to make a copy of such information before handing your phone in for repair.

For more support go to  
[www.SonyEricsson.com/support](http://www.SonyEricsson.com/support).

#### ***I have problems with memory capacity or the phone working slowly***

*Possible cause:* The phone memory is full or the memory contents are not properly organized.

*Solution:* Restart your phone every day to free memory and increase the capacity of your phone.

You also have the option to do a **Master reset**. Some of your personal data and settings you have made will be lost when doing this. ➡ 82 *Master reset*.

#### ***No battery icon appears when I start charging the phone***

*Possible cause:* The battery is empty or has not been used for a long time.

*Solution:* It may take up to 30 minutes before the battery icon appears on the screen.

#### ***Some menu options appear in grey***

*Possible cause:* Grey text indicates a function that is temporarily unavailable. A service is not activated or your subscription does not support the function.

*Solution:* Contact your network operator.

*Possible cause:* Since you cannot send themes, pictures and sounds that are copyright-protected, the **Send** menu is sometimes unavailable.

#### ***I do not understand the language in menus***

*Possible cause:* The wrong language is set in the phone.

*Solution:* Change the language, ➡ 14 *Phone language*.

#### ***I cannot turn on the phone***

*Possible cause:* The battery is discharged.

*Solution:* Recharge the battery, ➡ 7 *To charge the battery*.



*Solution:* Make sure you attached the charger correctly. Turn the phone on with the charger attached. If the phone starts, restart the phone with no charger attached.

### **I cannot charge the phone or battery capacity is low**

*Possible cause:* The charger is not properly connected to the phone.

*Solution:* Make sure that the charger connector clicks properly into place when connected. The battery icon flashes when charging is in progress, and stops when the battery is fully charged, ➤ 7 To charge the battery.

*Possible cause:* The battery connection is bad.

*Solution:* Remove the battery and clean the connectors. You can use a soft brush, cloth or q-tip, soaked with alcohol. Make sure that the battery is completely dry before you put it back. Check that the battery connectors in the phone are undamaged.

*Possible cause:* The battery is worn out and needs to be replaced.

*Solution:* Try another battery and charger for the same phone model, or visit your retailer and ask them to verify if the battery and charger are working properly.

### **The phone turns itself off**

*Possible cause:* The **Ⓛ** button has been pushed unintentionally.

*Solution:* Turn on the automatic key lock, or lock the keypad manually, ➤ 77 Keypad lock.

*Possible cause:* The battery connection is bad.

*Solution:* Make sure the battery is inserted correctly, ➤ 6 To insert SIM card and battery.

### **I cannot use SMS/text messages on my phone**

*Possible cause:* Settings are missing or incorrect.

*Solution:* Contact your network operator to find out the correct SMS service centre setting, ➤ 38 Text messaging (SMS).

### **I cannot use MMS/picture messages on my phone**

*Possible cause:* Your subscription does not include data capability.

*Solution:* Please contact your network operator.

*Possible cause:* Settings are missing or incorrect.

*Solution:* Go to [www.SonyEricsson.com/support](http://www.SonyEricsson.com/support), choose your phone model, then choose “Phone setup – MMS” and follow the instructions.

➤ 61 Settings.

### **I cannot use the Internet/WAP**

*Possible cause:* Your subscription does not include data capability.

*Solution:* Please contact your network operator.

*Possible cause:* Internet settings are missing or incorrect.

*Solution:* Go to [www.SonyEricsson.com/support](http://www.SonyEricsson.com/support), choose your phone model, then choose “Phone setup – WAP” and follow the instructions.

➡ 61 Settings.

### **The phone cannot be detected by other users via Bluetooth**

*Possible cause:* You have not turned Bluetooth on.

*Solution:* Make sure that Bluetooth is turned on and that your phone is visible to other users. ➡ 67 To hide or show your phone when using Bluetooth.

### **I have problems synchronizing or transferring data between my phone and my computer, when using the USB cable that came with the phone**

*Possible cause:* The cable has not been properly detected and installed on your computer.

The software that came with your phone has not been properly installed on the computer.

*Solution:* Go to [www.SonyEricsson.com/support](http://www.SonyEricsson.com/support), choose your phone model, then choose “Product information” - “Getting started”. The guide “Synchronizing the phone with a computer” contains installation instructions and a troubleshooting guide, that may assist you in solving the problem.

### **Master reset**

The changes that you have made to settings and the content that you have added or edited, will be deleted.

- If you select **Reset settings**, the changes that you have made to settings will be deleted.
- If you select **Reset all**, in addition to your changes to settings, all contacts, messages, personal data, and content that you have downloaded, received or edited will also be deleted.

### **To reset the phone**

- 1 ▶ Settings ▶ the General tab ▶ Master reset.
- 2 ▶ Reset settings or ▶ Reset all.
- 3 ▶ Yes to continue.
- 4 Enter the phone lock code (0000 or the new code if you have changed it) ▶ OK.

 If you select **Reset all**, content such as melodies and pictures that you have downloaded, received or edited is also deleted.

### Error messages

#### Insert SIM

*Possible cause:* There is no SIM card in the phone or you may have inserted it incorrectly.

*Solution:* Insert a SIM card. ➡ 6 To insert SIM card and battery.

*Possible cause:* The SIM card connectors need cleaning.

*Solution:* Remove the SIM card and clean it. Also check that the card is not damaged in a way that may prevent connection to the phone connectors. In that case, contact your network operator for a new SIM card.

#### Insert correct SIM card

*Possible cause:* The phone is set to work only with certain SIM cards.

*Solution:* Check if you are using the correct operator SIM card for your phone.

#### Wrong PIN/Wrong PIN2

*Possible cause:* You have entered your PIN or PIN2 incorrectly.

*Solution:* Enter the correct PIN or PIN2 ► **Yes**.  
➡ 77 SIM card lock.

#### PIN blocked/PIN2 blocked

*Possible cause:* You have entered your PIN or PIN2 code incorrectly three times in a row.

*Solution:* To unblock, ➡ 77 SIM card lock.

#### Codes do not match

*Possible cause:* The two codes that you have entered do not match.

*Solution:* When you want to change a security code (for example your PIN) you have to confirm the new code by entering exactly the same code again.  
➡ 77 SIM card lock.

#### No netw. coverage

*Possible cause:* Your phone is not receiving any radio signal, or the received signal is too weak.

*Solution:* Contact your network operator and make sure that the network has coverage where you are. If so, try to do a new search.

*Possible cause:* The SIM card is not working properly.

## Troubleshooting

*Solution:* Insert your SIM card in another phone. If you still get the same or a similar message, please contact your network operator.

*Possible cause:* The phone is not working properly.

*Solution:* Insert your SIM card in another phone. If this works, it is probably the phone that is causing the problem. Please contact the nearest Sony Ericsson service location.

### Emerg. calls only

*Possible cause:* You are within range of a network, but you are not allowed to use it. However, in an emergency, some network operators allow you to call the international emergency number 112.

*Solution:* You have to move to get a signal that is strong enough. Contact your network operator and make sure your subscription is ok.

➡ *21 Emergency calls.*

### Phone locked

*Possible cause:* The phone is locked.

*Solution:* To unlock the phone, ➡ *78 Phone lock.*

### Phone lock code:

*Possible cause:* The phone lock code is required.

*Solution:* Enter the phone lock code. Your phone comes with the default phone lock code 0000.

You can change it to any four- to eight-digit code.

➡ *78 Phone lock.*

### PUK blocked

*Possible cause:* You entered your personal unblocking key code (PUK) incorrectly 10 times in a row.

*Solution:* Contact your network operator.

### Charging, alien battery

*Possible cause:* The battery that you are using is not a battery approved by Sony Ericsson.

*Solution:* ➡ *88 Battery use and care.*

## Additional information

*Sony Ericsson Consumer Web site, safe and efficient use, warranty, declaration of conformity.*

### Sony Ericsson Consumer Web site

On [www.SonyEricsson.com](http://www.SonyEricsson.com) there is a support section where help and tips are only a few clicks away. Here you find the latest computer software updates and tips on how to use your product more efficiently.

## Guidelines for Safe and Efficient Use

Please read this information before using your mobile phone.



### Recommendations

- Always treat your product with care and keep it in a clean and dust-free place.
- Do not expose your product to liquid or moisture or humidity.
- Do not expose your product to extreme high or low temperatures.



- Do not expose your product to open flames or lit tobacco products.
- Do not drop, throw or try to bend your product.
- Do not paint your product.
- Do not use your product near medical equipment without requesting permission.
- Do not use your product when in, or around aircraft, or areas posted "turn off two-way radio".
- Do not use your product in an area where a potentially explosive atmosphere exists.
- Do not place your product or install wireless equipment in the area above your car's air bag.
- Do not attempt to disassemble your product. Only Sony Ericsson authorised personnel should perform service.



### Antenna

Only use an antenna that has been specifically designed by Sony Ericsson for your mobile phone. Use of unauthorised or modified antennas could damage your mobile phone and may violate regulations, causing loss of performance and SAR levels above the recommended limits (see below).

### Efficient use

Hold your mobile phone as you would any other phone. Do not cover the top of the phone when in use, as this affects call quality and may cause the phone to operate at a higher power level than needed, thus shortening talk and standby times.

### **Radio frequency (RF) exposure and SAR**

Your mobile phone is a low-power radio transmitter and receiver. When it is turned on, it emits low levels of radio frequency energy (also known as radio waves or radio frequency fields).

Governments around the world have adopted comprehensive international safety guidelines, developed by scientific organizations, e.g. ICNIRP (International Commission on Non-Ionizing Radiation Protection) and IEEE (The Institute of Electrical and Electronics Engineers Inc.) through periodic and thorough evaluation of scientific studies. These guidelines establish permitted levels of radio wave exposure for the general population. The levels include a safety margin designed to assure the safety of all persons, regardless of age and health, and to account for any variations in measurements.

Specific Absorption Rate (SAR) is the unit of measurement for the amount of radio frequency energy absorbed by the body when using a mobile phone. The SAR value is determined at the highest certified power level in laboratory conditions, but the actual SAR level of the mobile phone while operating can be well below this value.

This is because the mobile phone is designed to use the minimum power required to reach the network.

Variations in SAR below the radio frequency exposure guidelines do not mean that there are variations in safety. While there may be differences in SAR levels among mobile phones, all Sony Ericsson mobile phone models are designed to meet radio frequency exposure guidelines.

A separate leaflet with SAR information for this mobile phone model is included with the material that comes with this mobile phone. This information can also be found, together with more information on radio frequency exposure and SAR, on:  
*www.SonyEricsson.com.*

### **Driving**

Please check if local laws and regulations restrict the use of mobile phones while driving or require drivers to use handsfree solutions. We recommend that you use only Sony Ericsson handsfree solutions intended for use with your product. Please note that because of possible interference to electronic equipment, some vehicle manufacturers forbid the use of mobile phones in their vehicles unless a handsfree kit with an external antenna supports the installation.

Always give full attention to driving and pull off the road and park before making or answering a call if driving conditions so require.

### Personal medical devices

Mobile phones may affect the operation of cardiac pacemakers and other implanted equipment. Please avoid placing the mobile phone over the pacemaker, e.g. in your breast pocket. When using the mobile phone, place it at the ear opposite the pacemaker. If a minimum distance of 15 cm (6 inches) is kept between the mobile phone and the pacemaker, the risk of interference is limited. If you have any reason to suspect that interference is taking place, immediately turn off your mobile phone. Contact your cardiologist for more information.

For other medical devices, please consult the manufacturer of the device.

### CHILDREN

DO NOT ALLOW CHILDREN TO PLAY WITH YOUR MOBILE PHONE OR ITS ACCESSORIES. THEY COULD HURT THEMSELVES OR OTHERS, OR COULD ACCIDENTALLY DAMAGE THE MOBILE PHONE OR ACCESSORY. YOUR MOBILE PHONE OR ITS ACCESSORY MAY CONTAIN SMALL PARTS THAT COULD BE DETACHED AND CREATE A CHOKING HAZARD.



### Disposal of old electrical & electronic equipment



This symbol on the product or on its packaging indicates that this product shall not be treated as household waste.

Instead it shall be handed over to the applicable collection point for the recycling of electrical and electronic equipment. By ensuring this product is disposed of correctly, you will help prevent potential negative consequences for the environment and human health, which could otherwise be caused by inappropriate waste handling of this product. The recycling of materials will help to conserve natural resources. For more detailed information about recycling of this product, please contact your local city office, your household waste disposal service or the shop where you purchased the product.

### Power supply

Connect the AC power adapter only to designated power sources as marked on the product. Make sure the cord is positioned so that it will not be subjected to damage or stress. To reduce risk of electric shock, unplug the unit from any power source before attempting to clean it. The AC power adapter must not be used outdoors or in damp areas. Never alter the cord or plug. If the plug will not fit into the outlet, have a proper outlet installed by a qualified electrician.

## Additional information

### Emergency calls

Mobile phones operate using radio signals, which cannot guarantee connection under all conditions. Therefore you should never rely solely upon any mobile phone for essential communications (e.g. medical emergencies).

Emergency calls may not be possible on all cellular networks or when certain network services and/or mobile phone features are in use. Check with your local service provider.

### Battery use and care

We recommend that you fully charge the battery before you use your mobile phone for the first time. The battery can only be charged in temperatures between +5°C (+41°F) and +45°C (+113°F).

A new battery or one that has not been used for a long time could have reduced capacity the first few times it is used.

The talk and standby times depend on the actual transmission conditions when using the mobile phone. If the mobile phone is used near a base station, less power is required and talk and standby times are prolonged.

- **Warning!** May explode if disposed of in fire.
- Use only Sony Ericsson branded original batteries and chargers intended for use with your mobile phone. Other chargers may not charge sufficiently or may

produce excessive heat. Using other batteries and chargers could be dangerous.

- Do not expose the battery to liquid.
- Do not let the metal contacts on the battery touch another metal object. This could short-circuit and damage the battery.
- Do not disassemble or modify the battery.
- Do not expose the battery to extreme temperatures, never above +60°C (+140°F). For maximum battery capacity, use the battery in room temperature.
- Turn off your mobile phone before removing the battery.
- Keep out of children's reach.
- Use the battery for the intended purpose only.
- Do not allow the battery to be put into the mouth. Battery electrolytes may be toxic if swallowed.



### Disposing of the battery

Please check local regulations for disposal of batteries or call your local Sony Ericsson Call Center for information.

The battery should never be placed in municipal waste. Use a battery disposal facility if available.





## Limited Warranty

Sony Ericsson Mobile Communications AB, S-221 88 Lund, Sweden, (Sony Ericsson), provides this Limited Warranty for your mobile phone and original accessory delivered with your mobile phone (hereinafter referred to as "Product").

Should your Product need warranty service, please return it to the dealer from whom it was purchased, or contact your local Sony Ericsson Call Center (national rates may apply) or visit [www.SonyEricsson.com](http://www.SonyEricsson.com) to get further information.

## Our warranty

Subject to the conditions of this Limited Warranty, Sony Ericsson warrants this Product to be free from defects in design, material and workmanship at the time of its original purchase by a consumer, and for a subsequent period of one (1) year.

## What we will do

If, during the warranty period, this Product fails to operate under normal use and service, due to defects in design, materials or workmanship, Sony Ericsson authorised distributors or service partners, in the country/region\* where you purchased the Product, will, at their option, either repair or replace the Product in accordance with the terms and conditions stipulated herein.

Sony Ericsson and its service partners reserve the right to charge a handling fee if a returned Product is found not to be under warranty according to the conditions below.

Please note that some of your personal settings, downloads or other information may be lost when your Sony Ericsson Product is repaired or replaced. At present Sony Ericsson may be prevented by applicable law, other regulation or technical restrictions from making a backup copy of certain downloads. Sony Ericsson does not take any responsibility for any lost information of any kind and will not reimburse you for any such loss. You should always make backup copies of all the information stored on your Sony Ericsson Product such as downloads, calendar and contacts before handing in your Sony Ericsson Product for repair or replacement.

## Conditions

- 1 The warranty is valid only if the original proof of purchase issued to the original purchaser by an, for this Product, Sony Ericsson authorised dealer, specifying the date of purchase and serial number\*\*, is presented with the Product to be repaired or replaced. Sony Ericsson reserves the right to refuse warranty service if this information has been removed or changed after the original purchase of the Product from the dealer.

## Additional information

**2** If Sony Ericsson repairs or replaces the Product, the repaired or replaced Product shall be warranted for the remaining time of the original warranty period or for ninety (90) days from the date of repair, whichever is longer. Repair or replacement may involve the use of functionally equivalent reconditioned units. Replaced parts or components will become the property of Sony Ericsson.

**3** This warranty does not cover any failure of the Product due to normal wear and tear, or due to misuse, including but not limited to use in other than the normal and customary manner, in accordance with the Sony Ericsson instructions for use and maintenance of the Product. Nor does this warranty cover any failure of the Product due to accident, software or hardware modification or adjustment, acts of God or damage resulting from liquid.

A rechargeable battery can be charged and discharged hundreds of times. However, it will eventually wear out – this is not a defect. When the talk-time or standby time is noticeably shorter, it is time to replace your battery. Sony Ericsson recommends that you use only batteries and chargers approved by Sony Ericsson.

Minor variations in display brightness and colour may occur between phones. There may be tiny bright or dark dots on the display. These are called defective pixels and occur when individual dots

have malfunctioned and can not be adjusted. Two defective pixels are deemed acceptable. Minor variations in camera image appearance may occur between phones. This is nothing uncommon and is not regarded as a defective camera module.

- 4** Since the cellular system on which the Product is to operate is provided by a carrier independent from Sony Ericsson, Sony Ericsson will not be responsible for the operation, availability, coverage, services or range of that system.
- 5** This warranty does not cover Product failures caused by installations, modifications, or repair or opening of the Product performed by a non-Sony Ericsson authorised person.
- 6** The warranty does not cover Product failures which have been caused by use of accessories or other peripheral devices which are not Sony Ericsson branded original accessories intended for use with the Product.
- 7** Tampering with any of the seals on the Product will void the warranty.
- 8** THERE ARE NO EXPRESS WARRANTIES, WHETHER WRITTEN OR ORAL, OTHER THAN THIS PRINTED LIMITED WARRANTY. ALL IMPLIED WARRANTIES, INCLUDING WITHOUT LIMITATION THE IMPLIED WARRANTIES OF MERCHANTABILITY OR FITNESS FOR A PARTICULAR PURPOSE, ARE LIMITED TO THE DURATION OF THIS LIMITED WARRANTY. IN

NO EVENT SHALL SONY ERICSSON OR ITS LICENSORS BE LIABLE FOR INCIDENTAL OR CONSEQUENTIAL DAMAGES OF ANY NATURE WHATSOEVER, INCLUDING BUT NOT LIMITED TO LOST PROFITS OR COMMERCIAL LOSS; TO THE FULL EXTENT THOSE DAMAGES CAN BE DISCLAIMED BY LAW.

Some countries/states do not allow the exclusion or limitation of incidental or consequential damages, or limitation of the duration of implied warranties, so the preceding limitations or exclusions may not apply to you.

The warranty provided does not affect the consumer's statutory rights under applicable legislation in force, nor the consumer's rights against the dealer arising from their sales/purchase contract.

### \*EUROPEAN UNION (EU)

If you have purchased your Product in an EU country you can have your Product serviced, under the conditions set out above, within the warranty period in any EU country where an identical Product is sold by an authorised Sony Ericsson distributor. To find out if your Product is sold in the EU country you are in, please call the local Sony Ericsson Call Center. Please observe that certain services may not be possible elsewhere than in the country of original purchase, for example due to the fact that your Product may have an interior or exterior which is different from equivalent models sold in other EU countries. It may not be possible to repair SIM-locked Products.

\*\* In some countries/regions additional information is requested. If so, this is clearly shown on the valid proof of purchase.

## Additional information

### FCC Statement

This device complies with Part 15 of the FCC rules. Operation is subject to the following two conditions: (1) This device may not cause harmful interference, and (2) This device must accept any interference received, including interference that may cause undesired operation.



### Declaration of Conformity

We, **Sony Ericsson Mobile Communications AB** of Nya Vattentorget

S-221 88 Lund, Sweden

declare under our sole responsibility that our product

**Sony Ericsson type AAD-3021023-BV**

and in combination with our accessories, to which this declaration relates is in conformity with the appropriate standards 3GPP TS 51.010-1, 3GPP TS 34.121, EN 301489-7, EN 301489-24, EN 300328, EN 301489-17 and EN 60950, following the provisions of, Radio Equipment and Telecommunication Terminal Equipment directive **99/5/EC** with requirements covering EMC directive **89/336/EEC**, and Low Voltage directive **73/23/EEC**.

Lund, May 2005

The CE mark, consisting of the letters 'C' and 'E' in a stylized, bold font, with the number '0682' below it.  
0682

A handwritten signature in black ink, appearing to read 'Hiroshi Yoshioka', written over a horizontal line.













*Hiroshi Yoshioka,*  
*Head of Product Business Unit GSM/UMTS*

We fulfil the requirements of the R&TTE Directive (**99/5/EC**).















## Icons

### *Icon descriptions*

#### Icon Description













	Press  to go to the main menu
	The 3G (UMTS) network is available
	Tells you the strength of the GSM network signal
	You are within your home zone
	You are in a premium charge zone
	Tells you the status of the battery
	Tells you that the battery is charging
	All phone transmitters are turned off
	You can use the media player only
	You cannot receive any incoming calls
	You have missed an incoming call
	All incoming calls are diverted to a defined number

#### Icon Description





	All signals are off, except the alarm
	The alarm clock has been set and is on
	The timer has been set and is on
	The stopwatch is working in the background
	You have set a reminder for an appointment
	You have set a reminder for a task
	A profile other than Normal has been chosen
	The magic word is activated
	Speaker phone is activated
	The card lock or phone lock is on
	A secure Internet connection is established
	You have received a text message
	You have received an email message
	Your phone is receiving a picture message

## Icons

### Icon Description

-  Your phone is sending a picture message
-  You have received a picture message
-  You have received a voice message
-  You have received a WAP push message
-  You have received an instant message
-  The infrared port is on
-  Infrared communication is in progress
-  Bluetooth is turned on
-  Bluetooth headset is connected to your phone
-  Data is being downloaded to the phone
-  Line 1 is in use for outgoing calls
-  Line 2 is in use for outgoing calls
-  Ciphering is currently not being provided by the network

### Icon Description

-  An ongoing call
-  The media player is running
-  A Java™ application is running
-  Your movie can be sent using MMS
-  Your movie is too large and cannot be sent using MMS

# Index

## A

- accept calls 34
- account settings, email 44
- activity menu 17
- alarm clock 71
- alerts 56
- animations 49
- answering
  - calls 20
  - using voice control 30
- answering service 28
- appointments 72
- area information 46
- ask to save 26
- assembling, phone 6
- automatic redialling 20

## B

- battery
  - charging 7
  - inserting 6
  - use and care 88

## bookmarks

- Internet 62
- bookmarks, Internet 62
- brightness
  - display 75
- browsing
  - Internet 61
- business cards 37
- buttons 9

## C

- calculator 76
- calendar 71–73
- call list 27
- call time 36
- call waiting 32
- caller-specific ringtones 56
- calling
  - from call list 28
  - from contacts 25
  - numbers in message 39
  - using voice dialling 29

## calls

- accepting 34
- answering 20
- automatic redialling 20
- diverting 31
- emergency 21
- fixed dialling 35
- handling two calls 33
- international 21
- making 8, 19
- making notes during 36
- missed 20
- putting on hold 32
- receiving 8, 20
- recording 59
- rejecting 20
- restricting 34
- speed dialling 28
- video 21
- camera 47–49
- cell information 46
- certificates, Internet security 64

## Index

charging, battery 7

code memo 78

codes

    PIN 7

    PUK 7

conference calls 33

connectors 9

contacts 23, 24

    adding phone contacts 24

    checking memory 25

    default contacts 23

    groups of 37

    synchronizing 64

cookies 63

copying

    to/from SIM card 27

## D

date, setting 71

declaration of conformity 92

directing sound 68

display

    brightness 75

diverting calls 31

## 96

## E

email

    using 44–46

## F

file manager 17

fixed dialling 35

## G

games 60

groups 37

## H

handsfree 68

help texts, in phone 12

hiding number 36

## I

icons 93

infrared port 69–70

international calls 21

Internet

    bookmarks 62

    browsing 61

    cookies 63

    security 63–64

    settings 61

## J

Java™, settings 63

## K

key sound 57

keypad lock 77

keys 9

keys and navigation 12

## L

language

    changing 14

    in phone 14

language in phone 80

letters

    entering 15–16

locks

    SIM card 77

long messages 40



**M**

- magic word 30
- main menu 12
- media player 52–54
- melodies 56–57
- memory status 25
- menu overview 10
- message alert 57
- messages
  - area information 46
  - cell information 46
  - email 44
  - picture 41, 43
  - text 38
  - voice 43
- microphone, turning off/on 20
- missed calls 20
- MMS *See* picture messages 41, 43
- multitap text input
  - entering 15
- music, playing 52
- MusicDJ™ 57

**N**

- navigating menus 12
- networks, selecting 19
- new events 17
- night mode 48
- notepad 36
- notes 73–74
- number
  - hiding 36
  - my own 34

**O**

- on if silent 56

**P**

- passcodes
  - Bluetooth 67
  - code memo 78
- passwords, Internet 63
- phone language 14
- phone lock 78
- phone overview 9
- PhotoDJ™ 50
- picture messages 41–43

- picture sizes 48
- pictures 49–51
  - edit 50
  - screen saver 50
  - wallpaper 50
- PIN code
  - changing 77
  - entering 8
- profiles 74
- PUK 77

**R**

- recording
  - calls 59
  - sounds 59
  - video clips 47
  - voice commands 29–31
- redialling 20
- remote control 69
- resetting phone 82
- restricted dialling 34
- ringtones 56–57
- roaming 19

## Index

### S

- safety guidelines 85
- saving
  - from picture messages 42
  - from text messages 39
- screen 75
- screen saver 50
- security
  - code memo 78
  - Internet 63–64
  - SIM card lock 77
- sending
  - appointments 73
  - business cards 37
  - contacts 27
  - melodies and ringtones 57
  - notes 74
  - pictures 50
  - tasks 73
  - themes 60
- settings for Java™ 63
- setup wizard 8
- shortcuts 14

### SIM card

- copying to/from 27
- inserting 6
- lock 77
- unlocking 77

SIM contacts 24

SIM numbers 25

SMS *See* text messages 38

SOS *See* emergency numbers 21

sound

- directing 68
- transferring 68

sound recorder 59

speaker volume 19

speed dialling 28

standby screen 12

start-up menu 75

start-up screen 50, 75

status bar 12

stopwatch 74

streaming media 54

synchronizing 64–65

### T

T9™ Text Input

- entering letters 16

tasks 73

templates

- for picture messages 43
- for text messages 40

text messages 38–40

themes 59–60

time, setting 71

timer 75

t-music 56

transfer method 38, 66, 69, 70

transferring sound 68

turning on/off

- Bluetooth 66
- infrared port 69
- key sound 57
- phone 8
- phone lock 78
- ringtones, melodies 56
- SIM lock protection 77

two voice lines 33

t-zones 63

**U**

- unblocking
  - PIN 7
  - SIM card 77
- USB cable 70

**V**

- vibrating alert 56
- video calls 21–23
- video clips 52
- video recorder 47–49
- VideoDJ™ 58
- voice answering 30–31
- voice control 29–31
- voice dialling 29–30
- voice messages 43
- voicemail 28
- volume
  - changing 19
  - setting ringtone 56
  - vibrating alert 56

**W**

- wallpaper 50
- WAP *See* Internet 61
- warranty 89
- wizard
  - setup 8
- writing
  - using multitap input 15
  - using T9™ Text Input 16
- writing languages 15

**Z**

- zoom 47